

Electronic Engineering

FEBRUARY 1952

NEW MOULDED-ON COUPLER

To B.B.C. Standard
for T/V Outside Broadcasts

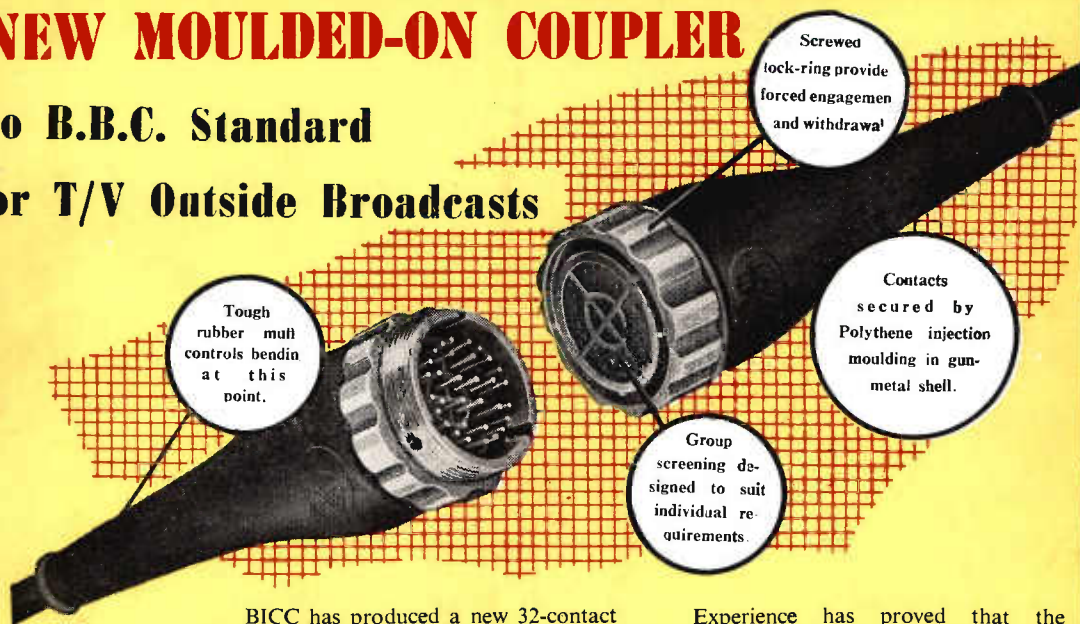

BICC has produced a new 32-contact Polypole Coupler and associated cable to meet the increasingly complex needs of modern television cameras.

This new coupler and cable, providing 4 co-axial and 24 other circuits, has been designed to the B.B.C. new standard requirements for Outside Broadcast Services.

Experience has proved that the combination of solid conductors and moulded-on couplers give the unit greater mechanical strength and freedom from conductor end-breakage.

BICC Television Camera Cables and Couplers are used with the majority of the B.B.C. Outside Broadcast Television Units.



POLYPOLE CABLE COUPLER

BRITISH INSULATED CALLENDER'S CABLES LIMITED
NORFOLK HOUSE, NORFOLK STREET, LONDON, W.C.2.

TWO SHILLINGS

The core of the Motor is the Electrical Stamping



SANKEYS....
ARE THE LARGEST
MANUFACTURERS
OF ELECTRICAL
STAMPINGS IN
EUROPE

SANKEYS
"STALLOY"
"LOHYS"
Electrical Sheets
are Rolled at
The MANOR WORKS

JOSEPH SANKEY & SONS LTD.

ESTABLISHED 1854

BANKFIELD WORKS, BILSTON STAFFS, ENG.

TELEGRAMS SANKEY · BILSTON

LONDON OFFICES · ULSTER CHAMBERS · 118 REGENT STREET W. 1

CLASSIFIED ANNOUNCEMENTS

The charge for these advertisements at the LINE RATE (if under 1" or 12 lines) is: Three lines or under 7/6, each additional line 2/6. (The line averages seven words.) Box number 2/- extra, except in the case of advertisements in "Situations Wanted," when it is added free of charge. At the INCH RATE (if over 1" or 12 lines) the charge is 30/- per inch, single column. Prospectuses and Company's Financial Reports £14 0s. 0d. per column. A remittance must accompany the advertisement. Replies to box numbers should be addressed to: "Electronic Engineering," 28, Essex Street, Strand, London, W.C.2. Advertisements must be received before the 14th of the month for insertion in the following issue.

OFFICIAL APPOINTMENTS

ADMIRALTY. Applications are invited from Engineering, Electrical and Ship Draughtsmen for temporary service in Admiralty Departments at Bath. Candidates must be British subjects of 21 years of age and upwards, who have had practical Workshop and Drawing Office experience. Salary will be assessed according to age, qualifications and experience within the range £320-£545 per annum. Applications giving age and details of technical qualifications, apprenticeship (or equivalents) Workshop and Drawing Office experience, should be sent to Admiralty (C.E.II, Room 88), Empire Hotel, Bath. Candidates required for interview will be advised within two weeks of receipt of application. W 137

ADMIRALTY. Technical Class Grade III vacancies exist in the Naval Ordnance Inspection Department for staff with knowledge of electronics. The posts are mainly in the London area and the duties involve acceptance tests and inspection of electronic equipment at manufacturer's works. Candidates must be British subjects, at least 25 years of age and should have served an apprenticeship or had equivalent workshop training, followed by experience in the manufacture of electric and electronic equipment. Possession of Ordinary National Certificate, preferably in telecommunications, or an equivalent City and Guilds Certificate, is desirable. Appointments will be temporary and unestablished. Opportunities may occur at a later date for qualified staff to secure established appointments which would carry possibilities of promotion to grades with higher salary scales. The Technical Class Grade III salary scale for the London area is £460 x £20-£575 per annum, and the point at which applicants will be entered within this range will depend on age, experience and ability. Applications, stating age, and details of technical qualifications, apprenticeship (or equivalent) and experience should be sent to the Inspector of Naval Ordnance, Middlegate House, Royal Arsenal, Woolwich, London, S.E.18. Original testimonials should not be forwarded with application. Candidates required for interview will be advised within two weeks of receipt of application. W 2429

APPLICATIONS are invited for posts as Lecturers at the R.E.M.E. Training Centre, Arborfield, under the War Department. Qualification required: A Degree in Electrical Engineering or an equivalent qualification. Experience in light current, radio or radar engineering is essential. Salaries will be in accordance with the Burnham Technical Scale for Assistants B and will allow for the special increments etc. attaching to Degree and other special qualifications. A special 75% non-portionable allowance is also payable. The service will reckon as contributory under the Teacher Superannuation Acts. Full particulars and forms of application may be obtained from the Under-Secretary of State, The War Office (M.E.I.), London, S.W.1. Closing date for applications 11th February 1952. W 2420

APPLICATIONS are invited by the Ministry of Supply for the following Experimental Officer Class posts at the Royal Aircraft Establishment, South Farnborough, Hants. (1) Senior Experimental Officer—Electronic Engineer for work of the following types: (a) R.F. measurements in the V.H.F. and centimetric bands, (b) design of R.F. systems operating in these frequency bands, (c) design of electronic test equipment, (d) General circuit design. Candidates should be experienced in as many of the above as possible. Ref. D.585/51-A. (2) Senior Experimental Officer or Experimental Officer—Electronic Engineer for radar applications work. Candidates should have experience in microwave radar. Ref. D.586/51-A. (3) Experimental Officer or Assistant Experimental Officer—Electrical or Mechanical Engineer for work on the development of aircraft equipment and associated installation in aircraft. Duties will include attendance at outdoor trials, and willingness to fly as an observer during flight trials would be an asset. Ref. D.587/51-A. Knowledge of aircraft structures, aircraft armament, gun design or the application of electronic techniques would be an advantage. Candidates should possess the Higher National Cer-

tificate or equivalent qualification, in the appropriate subject. Salary will be assessed according to age, qualifications and experience within the ranges: Senior Experimental Officer (minimum age normally 35)—£742 to £960. Experimental Officer (minimum age normally 28)—£545 to £695. Assistant Experimental Officer—£240 (at age 18) to £505. Rates for women somewhat lower. The posts are unestablished. Application forms obtainable from Ministry of Labour and National Service, Technical and Scientific Register (K), Almack House, 26 King Street, S.W.1, quoting appropriate reference number. Closing date 15th February, 1952. W 2419

APPLICATIONS are invited by the Ministry of Supply for vacancies in the Experimental Officer Class at the Atomic Energy Research Establishment, Harwell, Berks., for work in the following fields: Physics, Electronics and Scientific Computing (Ref. A309/51A), and Chemistry (other than Organic Chemistry), Chemical Engineering and Metallurgy (Ref. F777/51A). These posts offer a wide variety of experimental work in connexion with the development of atomic energy and the opportunity for a career in an increasingly important branch of science. Candidates should possess at least Higher School Certificate or Higher National Certificate in a relevant scientific subject or mathematics or equivalent qualifications. Higher qualifications will be an advantage. Appointments will be made according to qualifications, experience and age within the following salary ranges: Experimental Officer (male) £545-£695 per annum. Assistant Experimental Officer (male) £240 (at age 18)—£505 per annum. Rates for women somewhat lower. Application forms obtainable from Ministry of Labour and National Service, Technical and Scientific Register, (K), Almack House, 26 King Street, London, S.W.1, quoting the appropriate Ref. No. W 2398

APPLICATIONS are invited by the Ministry of Supply for the following Scientific Officer class posts in the Radio Department of the Royal Aircraft Establishment, Farnborough; Senior Scientific Officer to work on research and development of airborne and ground radio navigation equipment and the supervision of relevant development contracts with industry. Candidates should be experienced in the development of radio navigational aids and have some knowledge of the planning and supervision of tests and evaluation trials of completed systems. (Ref. A394/51A). Scientific Officer for experimental work on new techniques and systems for communications, navigation, and radio control, using very high frequencies. (Ref. A395/51A). Scientific Officer for research on electro-acoustic problems occurring in aviation including voice transmission in the presence of high noise levels, and measurement and assessment of microphone and telephone performance. (Ref. A396/51A). Candidates should have a 1st or 2nd class Honours Degree in Physics or Electrical Engineering, or equivalent qualifications. For the senior grade candidates should be at least 26 years of age with at least 3 years' post-graduate research experience. Salaries will be assessed according to age, qualifications and experience within the ranges: Senior Scientific Officer—£720 to £910. Scientific Officer—£380 to £620. Rates for women somewhat lower. Posts are unestablished but carry benefits under F.S.S.U. Application forms obtainable from Technical and Scientific Register (K), Almack House, 26-28 King Street, London S.W.1, quoting appropriate reference number. W 2410

APPLICATIONS are invited by the Ministry of Supply for the following posts in the Experimental Officer class in the Radio Department of the Royal Aircraft Establishment, Farnborough: (1) Senior Experimental Officer to work on development of air and ground transmitters on V.H.F. and decimetre wavelengths and of various power levels. Sound electrical and mechanical design ability is required in this field with thorough theoretical background, together with considerable experience of active development work on radio or electronics equipment. Ref. A405/51A. (2) Experimental Officer for work on the development of radio control telemetering equipment and for supervision of relevant development contracts with industry. A sound knowledge of radio and

light electrical engineering is essential and knowledge of telephone techniques (e.g., filters, relays, etc.) would be an advantage. Ref. D579/51A. (3) Assistant Experimental Officer for Control Tower work. Candidates should have a sound knowledge of the basic principles of radio and radar, and practical experience of ground based radio communications equipment, radio navigation equipment and radar equipment, including planning of airfield radio installations, would be an advantage. Ref. D580/51A. (4) Assistant Experimental Officers for laboratory work on aeronautical radio communication, navigation and electronic equipment. Duties are likely to include field investigations and observations in flight. Ref. A406/51A. Acceptable qualifications include Higher School Certificate with Physics and Mathematics as principal subjects, Grad.I.E.E. and Higher National Certificate in Radio or Electrical Engineering. A Degree in Physics or Electrical Engineering may be an advantage for some posts. Salary will be assessed according to age, qualifications and experience within the ranges: Senior Experimental Officer (minimum age 35)—£742-£960. Experimental Officer (minimum age 28)—£545-£695. Assistant Experimental Officer £240 (at age 18)—£505. Rates for women somewhat lower. The posts are unestablished. Application forms obtainable from Technical and Scientific Register (K), Almack House, 26 King Street, S.W.1, quoting appropriate reference number. Closing date 12th February, 1952. W 2413

ASSISTANT (Scientific) Class: The Civil Service Commissioners give notice that an Open Competition for pensionable appointment to the basic grade will be held during 1952. Interviews will be held throughout the year, but a closing date for the receipt of applications earlier than December, 1952, may eventually be announced either for the competition as a whole or in one or more subjects. Successful candidates may expect early appointments. Candidates must be at least 17½ and under 26 years of age on 1st January 1952, with extension for regular service in H.M. Forces, but other candidates over 26 with specialised experience may be admitted. All candidates must produce evidence of having reached a prescribed standard of education particularly in a science subject and of thorough experience in the duties of the class gained by service in a Government Department or other civilian scientific establishment or in technical branches of the Forces, covering a minimum of two years in one of the following groups of scientific subjects: (i) Engineering and physical sciences. (ii) Chemistry, bio-chemistry and metallurgy. (iii) Biological Sciences. (iv) General (including geology, meteorology, general work ranging over two or more groups (i) and (iii) and highly skilled work in laboratory crafts (such as glass-blowing). Salary according to age up to 25: £215 at 18 to £330 (men) or £300 (women) at 25 to £455 (men) or £380 (women); somewhat less in the provinces. Opportunities for promotion. Further particulars and application forms from Civil Service Commission, Scientific Branch, Trinidad House, Old Burlington Street, London, W.1, quoting No. S59/52. Completed application forms should be returned as soon as possible. W 2424

GRAYLINGWELL HOSPITAL, Chichester. Applications are invited for the post of EEG Recordist at Graylingwell Hospital, Chichester. An experienced worker is required and training or knowledge of electronics would be an advantage. The appointed candidate will be expected to carry out routine work in the EEG Department, but would also take part in investigations conducted by the Department of Clinical Research. Two machines are in whole-time use, an 8-channel as well as a 6-channel Ediswan. Salary will be on the scale £350-£420 according to age and experience. The appointment will be on a temporary basis in the first instance. Applications to the Medical Superintendent. W 1404

LIGHT ELECTRICAL and Electronic Engineers required by Ministry of Supply in London and the provinces for the design, development, production and inspection of light and medium weight electrical, electro-mechanical, radio, radar and electronic equipment (airborne and portable) including: servo systems

OFFICIAL APPOINTMENTS (Cont'd.)

and mechanisms, power supply (rotary and vibratory), radio communication, telemetry, circuit design (electronic), electronic valves and ammunition fuzes. Qualifications: British, of British parentage; regular engineering apprenticeship and either be corporate members of one of the Institutions of Civil, Mechanical or Electrical Engineers or exempting qualifications, with appropriate experience in any of the above fields. An extensive knowledge of physics is essential for research and development in electronics. Salary: Within the range £600-£1,450 p.a. (London) dependent on age, qualifications and experience. Rates in provinces and for women slightly lower. Not established, periodical competitions for established pensionable posts. Paid sick leave; annual leave initially 25 days (30 in London) plus public holidays; normal working week 44 hours. Application forms from Ministry of Labour and National Service, Technical and Scientific Register (K), Almack House, 26-28 King Street, London, S.W.1, quoting D408/51A. W 2411

PROFESSIONAL ENGINEERS in Government Departments. The Civil Service Commissioners announce an Open Competition for permanent appointments of Professional Engineers, General Service Class (Main and Senior grades). The vacancies at present announced are in the Admiralty (not less than 6 in the Main Grade and one in the Senior Grade). The duties in the Admiralty cover the production of mechanical, electrical and electronic equipment for H.M. Ships and include design for production correlation of manufacturing requirements and capacity, advice on production methods, preparation of estimates and, in certain cases, material inspection and functional testing. Candidates must be at least 30 years of age on 1st January 1951. Minimum qualifications. Generally Corporate Membership of the Institution of Mechanical Engineers, or Electrical Engineers is required, together with evidence of apprenticeship or pupillage and subsequent engineering experience. Exceptionally, candidates of high professional attainments without some or all of these qualifications may be admitted. Salary scales: London. Men Main Grade £900-£1,200. Senior Grade £1,250-£1,450. Women. Main Grade £650-£850. Senior Grade £900-£1,100. Provinces Men £860-£1,140. Senior Grade £1,177-£1,370. Women Main Grade £620-£810. Senior Grade £860-£1,040. The rates for women are at present under review. A starting pay above minimum may be recommended for exceptionally well qualified candidates. Further particulars and application forms from Secretary, Civil Service Commission, Trinidad House, Old Burlington Street, London, W.1, quoting No. S86/51. Applications will be accepted at any time but not later than 29th February, 1952, and selected candidates will be interviewed as soon as possible after receipt of their Application Forms. Candidates are advised to apply as early as possible as a closing date earlier than 29th February may eventually be announced. W 2412

PROFESSIONAL ENGINEERS in Government Departments. The Civil Service Commissioners announce an Open Competition to be held during 1951-52 for permanent appointments in many Departments of the Civil Service for wide variety of engineering duties. Applications will be accepted at any time but not later than 31st March, 1952, and selected candidates will be interviewed as soon as possible after the receipt of their Application Forms. Candidates are advised to apply as early as possible. Age limits: Candidates must be under 35 on 30th November, 1951 with extension for regular service in H.M. Forces and for established Civil Service. For appointments in the Post Office they must be 21 or over, in the Ministry of Supply, 23, and in all other Departments 25 or over on that date. Minimum qualifications vary for different posts. Generally a University Degree in Engineering or Corporate Membership of the Institutions of Mechanical Engineers, Electrical Engineers or Civil Engineers, or passes in or exemption from Sections A and B of the corresponding Associate Membership examinations, or evidence of exceptionally high professional attainment are required. For certain posts, Corporate Membership of the Institute of Fuel by examination or the Institution of Chemical Engineers, or Graduate Membership of the Institution of Chemical Engineers, or Associate Fellowship of the Royal Aeronautical Society or an Honours Degree in Physics will be accepted instead. The salary on appointment will be fixed according to age. The salary for men aged 25 in London is £75 rising by annual increments of £25 to £750, and by £30 to £900. Salaries for women and for

posts outside London are lower. There are prospects of promotion to higher grades on scales for men in London of £900-£1,200, £1,250-£1,450 and above. Further particulars and application forms from Secretary, Civil Service Commission, Trinidad House, Old Burlington Street, London, W.1, quoting No. S85/51. W 2432

ROYAL CANCER HOSPITAL, Fulham Road, London, S.W.3. Male Technician required for Electronics Group in the Physics Department. Applicants must be (a) Experienced in the assembly, wiring and preferably initial testing of experimental electronic apparatus; (b) capable of working to circuit diagrams; (c) able to convert experimentally proved circuits into finished instruments for clinical use. Salary in accordance with the scale for Medical Laboratory Technicians. Applications giving the names of three persons to whom reference can be made, must be received not later than two weeks from the date of this advertisement by the House Governor, Royal Cancer Hospital, London, S.W.3. W 2448

TECHNICAL GRADES II and III required for Ministry of Supply Establishment at Malvern, Worcestershire. Qualifications: British of British parentage; apprenticeship in radio or electrical engineering with knowledge of use or maintenance of electronic or light electrical equipment; be familiar with engineering drawings and drawing office procedure. Possession of Higher National Certificate (Ordinary National Certificate for Grade III) or equivalent qualification desirable. Duties: Preparation of radio equipment schedules, including spares and servicing recommendations for new radar installations and associated electrical equipment. Additionally for Grade II the preparation of technical information on modifications. Salary: Grade II £540 (linked to age 30)—£645 p.a. Grade III £437 (linked to age 26)—£545 p.a. (rates for women slightly lower). Not established, opportunities for established pensionable posts may arise. Application forms from Ministry of Labour and National Service, Technical and Scientific Register (K), Almack House, 26 King Street, London, S.W.1, quoting Ref. No. D563/51A. W 2395

SITUATIONS VACANT

AN INSTRUMENT MECHANIC is required for duties in the Electronics Section of the Research and Experimental Department. Applicants should possess a high degree of mechanical skill and be able to participate intelligently in both design and manufacture of small electro-mechanical devices. Experience in a similar capacity, whilst desirable is not essential. Write, stating age, experience and salary expected to the Personnel Officer, Saunders-Roe Limited, East Cowes, I.O.W. W 2323

A NEW DEFENCE PROJECT of National Importance being undertaken by a well known Aircraft Company located in the Northern Outskirts of London, offers highly paid and interesting posts for suitably qualified applicants. Vacancies exist in Senior (salaried grades) and for Junior Engineers in various categories: (a) Physicists with experience in electronic problems. (b) Physicists with experience in optical work. (c) Electronic Engineers with Servo-Mechanism experience. (d) Electronic Engineers with experience of low frequency work and measuring systems. (e) Electrical Engineers with experience in small motor design and development. Applicants for Senior posts should possess a good University Degree and preferably should have some industrial experience. Applicants for Junior posts should have a good industrial experience, be qualified either by City & Guilds certificate or by Inter B.Sc. Write full details, qualifications, experience, age, salary sought to Box A.C. 65489 Samson Clarks, 57-61 Mortimer Street, W.1. W 2136

A NUMBER of Senior and Junior vacancies for Radio, Radar, Electronic, Television, etc., Development, Service Engineers, Draughtsmen, Wiremen, Testers, Inspectors, etc. Urgently required, 30 Television Service Engineers. Write in confidence: Technical Employment Agency, 179 Clapham Road, London, S.W.9. (BR)IXton 3487. W 113

A PROJECT ENGINEER (Electrical) is required by a firm of Instrument Makers to supervise the activities of a development laboratory engaged on projects covering specialised instrument and electronic equipment for aircraft. Applicants should possess a University Degree or Higher National Certificate in Electrical Engineering or similar qualifications, and have had previous laboratory experience in this type of

work, together with a knowledge of current design practice. Write, giving details of qualifications and experience to Box No. W 1393

A PROJECT ENGINEER required for new factory in Northamptonshire manufacturing materials for the radio, radar and electronic industries. Applicant will be associated with processes producing various types of magnetic iron cores and will be responsible for the development of new types of cores and improved production methods. Mechanical and electronic engineering experience essential. Previous experience of powder metallurgy processes desirable. State age, qualifications, experience and salary required. Box No. W 2404

A WELL-KNOWN Midland Company requires an R.F. Heater Applications Engineer for test work on samples and the design of applicators. Men with metallurgical knowledge and at least H.N.C. should apply, giving full details of qualifications and experience, quoting Ref. HFH to Box No. W 2438

A WELL-KNOWN progressive Company has a vacancy in a rapidly expanding Commercial Department for a Technical Sales Executive for Radio and Radar apparatus. Candidates should have a good University Degree together with industrial and/or Government experience, a methodical nature with a flair for organisation and a genuine interest in the varied types of work undertaken by sales engineers. Importance will be attached to the adaptability of applicants and to their suitability to handle both technically and commercially a variety of equipment and to deal with customers at all levels. The post is permanent and has very good prospects for advancement. Applications will be treated in strict confidence. Please forward detailed personal information and salary required to Box No. W 2401.

APPLICATIONS are invited for positions in the Radio Section of the Design Office of the G.E.C. Research Laboratories for work at Stanmore (Middlesex). Candidates must be capable of making first class engineering drawings of sub-assemblies and fully dimensioned details of airborne radio and radar equipments for quantity production. Knowledge of Inter-Service specifications and standards would be an advantage. Special starting salaries will be given for outstanding ability. Write to the Staff Manager (Ref. GBLC/422), Research Laboratories of The General Electric Co., Ltd., North Wembley, Middlesex, giving age, qualifications and experience. W 2442

BELLING & LEE LTD., Cambridge Arterial Road, Enfield, Middlesex, require research assistants in connexion with work on electronic components, fuses, interference suppressors and television aerials. Applicants must be graduates of the I.E.E. or possess equivalent qualifications together with similar laboratory experience. Salary will be commensurate with previous experience. Applications must be detailed and concise, and will be treated as confidential. W 138

BRITISH TELECOMMUNICATIONS Research Ltd., a company associated with Automatic Telephone & Electric Co. Ltd., and British Insulated Callender's Cables Ltd. require a well qualified development engineer for work on Transmission Networks and Wave Filters. Applicants should have had previous experience in this field. An attractive salary will be offered to suitably qualified candidates. The position will be permanent and is covered by the super-annuation scheme. Application should be made to the Director of Research, B.T.R. Ltd., Taplow Court, Taplow, Bucks, giving full details of qualifications and experience. W 2435

CATHODE RAY Tube Engineer required to assist in work on design and development of Teletubes. Physics Degree desirable, with knowledge of Chemistry an asset, but applicants with experience of this work preferred. Excellent facilities for man wishing to specialise in this field. Salary in accordance with qualifications. Apply in writing to the Personnel Officer, Brimar Valve Works, Foots Cray, Sidcup, Kent. W 2428

DESIGN AND DEVELOPMENT Section of a large Engineering Company of national repute situated in the West Country has vacancies for: (1) Senior Design Draughtsman with specialised experience of the design of special purpose Automatic Process machines and Hopper and Feed mechanisms for small components. (2) Design Draughtsman with experience of design and development of Radio components. (3)

CLASSIFIED ANNOUNCEMENTS
continued on page 4



QUALITY

ACCURACY

RELIABILITY

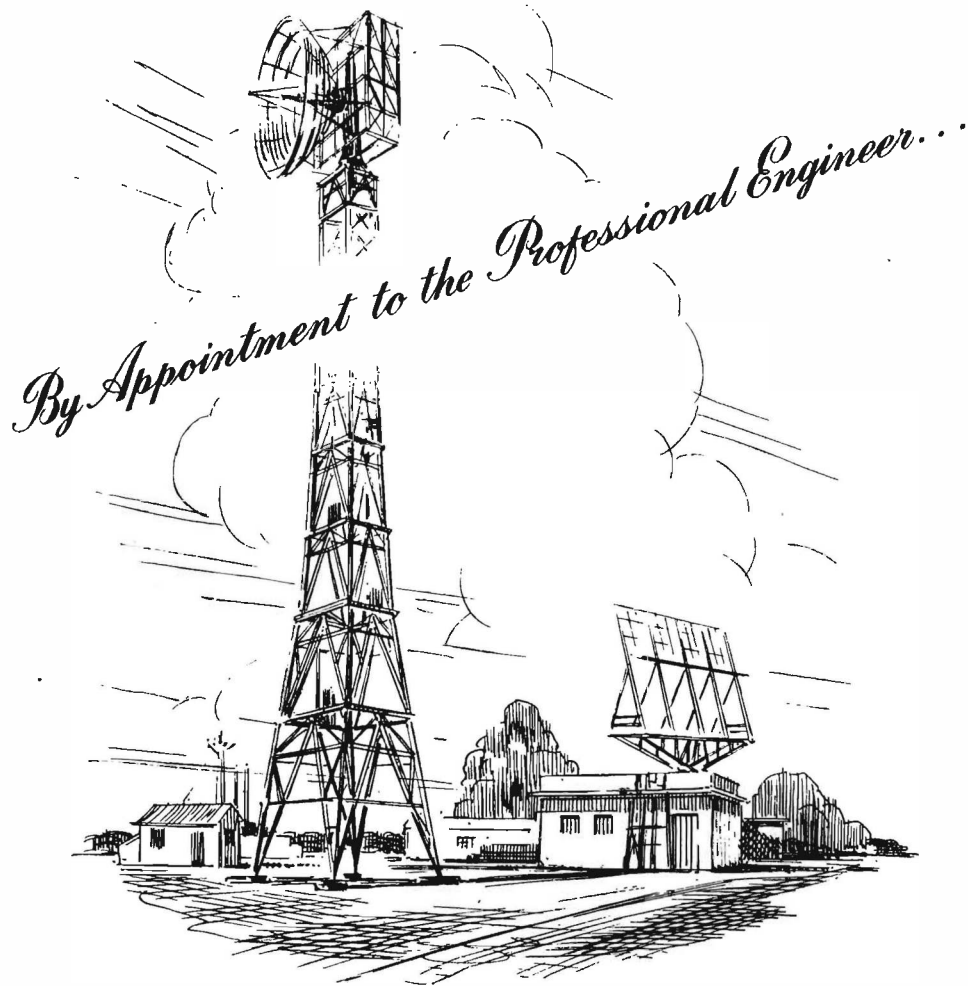

By Appointment to the Professional Engineer...

ATTENUATORS · FADERS · SWITCHES · WIREWOUND POTENTIOMETERS · PLUGS
AND SOCKETS · WIREWOUND RESISTORS · HIGH STABILITY CARBON RESISTORS
KNOBS DIALS AND POINTERS · TERMINALS

PAINTON

Northampton England

SITUATIONS VACANT (Cont'd.)

Development Engineer for pre-production Laboratory development of Radio components and small mechanisms. These appointments are of a permanent and progressive nature. Pension scheme in operation. Salaries according to qualification and experience. Please write stating age and experience to Box No. W 2402

DEVELOPMENT ENGINEER experienced in design of Electrical Measuring Instruments and devices. Higher National Certificate essential. Write fully stating age, education and particulars of posts held to Box E.E. 632 at 191, Gresham House, E.C.2. W 2367

DRAUGHTSMAN required for an experimental office machinery project. Applicants should have experience in the design of assemblies, using gears and light alloy castings, and should preferably have some electrical knowledge. The work on the project will be for at least one year and will be in the London and/or Croydon district. Write stating age, experience, salary required to Box No. W 2406.

DRAUGHTSMEN (Senior and Junior) required in Research Department for design and detail work on special Radar and Electro-mechanical equipment. West London area. Write giving full particulars of experience, age and salary required to Box A.E. 693, Central News Limited, 17 Moorgate, London, E.C.2. W 2386

DIGITAL COMPUTERS: There are vacancies in the Computer Section of Ferranti Limited for the following: (a) Circuit Engineer, experienced in pulse or radar circuits with an interest in the development of circuits associated with high speed mechanical devices. Some mechanical engineering background is desirable but not essential. Ref. D.C.C. (b) Mechanical Engineer with wide experience in design of precision high speed mechanical devices. An interest in electronics is preferred but not essential. Ref. D.C. Mech. (c) Engineer with wide experience of magnetic recording equipments required for interesting new project. Ref. D.C. Mag. Salary for the above posts will be in accordance with experience and ability, in the range £520-£1,000 per annum. Contributory Pension Scheme in operation. Forms of application from Mr. R. J. Hebbert, Staff Manager, Ferranti, Ltd., Hollinwood, Lancs. W 2346

EXPERIENCED ELECTRONIC ENGINEERS required for interesting development work on a number of projects. Applicants should have a sound theoretical background with several years' experience in the design and engineering of prototype electronic equipment. The posts are for permanent staff and offer good salaries and prospects. Please write giving full details and quoting ED/63, to Personnel Department, E.M.I. Engineering Development Limited, Hayes, Middlesex. W 2444

ENGINEER, experienced in the design of complex light mechanisms, required for interesting development work. Qualifications: Degree or Higher National Certificate in engineering, physics or mathematics with some experience of two of the following: Hydraulics, Gyro-mechanisms, Stressing Metallurgy, Optics or Electronics. The post is permanent, pensionable and offers good starting salary and prospects. Applicants should write, giving full details to: Personnel Department (ED/63), E.M.I. Engineering Development Limited, Hayes, Middlesex. W 2443

E. K. COLE LIMITED (Malmesbury Division), invite applications from Electronic Engineers for permanent posts in Development Laboratories engaged on long-term projects involving the following techniques: 1. Pulse Generations and Transmission. 2. Servo Mechanisms. 3. Centimetric and V.H.F. Systems. 4. Video and Feedback Amplifiers. 5. V.H.F. Transmission and Reception. 6. Electronics as applied to Atomic Physics. There are vacancies in the Senior Engineer, Engineer and Junior Grades. Candidates should have at least 3 years' industrial experience in the above types of work, together with educational qualifications equivalent to A.M.I.E.E. examination standard. Commencing salary and status will be commensurate with qualifications and experience. Excellent opportunities for advancement are offered with entry into Pension Scheme after a period of service. Forms of application may be obtained from Personnel Manager, Ekco Works, Malmesbury, Wilts. W 2321

ELECTRICAL AND RADIO DRAUGHTSMEN required. Apply Employment Manager, Vickers-Armstrongs Ltd. (Aircraft Section), Weybridge, Surrey. W 2350

ELECTRONIC DEVELOPMENT ENGINEER required to join staff of expanding Laboratory

team working on Government and Industrial contracts. Experience of video techniques essential; experience of waveguide techniques desirable. Salary £700 p.a. Good opportunity for energetic man. Write stating experience to Technical Director, Winston Electronics Limited, 1 Park Road, Hampton Hill, Middlesex. W 1385

ELECTRONIC ENGINEERS required in the Weybridge district. Experienced in installation, inspection and testing of electronic equipment to Ministry standard. Write stating age, experience, qualifications and salary required to Box P.812, Willings, 362 Gray's Inn Road, London, W.C.1. W 2256

ELECTRONIC ENGINEER or Physicist of high academic attainments and first-class practical background, to build up and take charge of an important and potentially large new Electronics Development Department undertaking Radio and Radar Electronic cum Mechanical projects. Experience of Service ship-borne equipment an advantage. A man of considerable drive and energy is required who would be directly responsible to the Board of Directors. Housing accommodation available. Application to be addressed to The Secretary, Messrs. Barr and Stroud Limited, Anniesland, Glasgow, W.3. W 2408

ELECTRONIC ENGINEERS required for Research Laboratory, Associated Electrical Industries Limited, Aldermaston Court, Berks. Applicants should have had sufficient research experience to design electronic equipment for physicists engaged on fundamental research. Send full details of qualifications, experience and salary required to the Director. W 2441

ELECTRICAL HEARING AIDS and Components—John Bell & Croyden, 117 High Street, Oxford, require an Assistant Works Manager. Sound electronic knowledge essential and some experience with production of components or small assemblies desirable. Write giving details of qualifications and experience. W 2417

ELECTRONIC RESEARCH and Development (a) Physicists, Engineers and Chemists are urgently required for interesting projects in the vacuum physics and semi-conductors fields. Candidates should be graduates of a British University and preferably with some experience in these fields. Alternatively really good men without specialised experience but who are keenly interested in electronic tube research and development will receive consideration. (b) Technicians to join research and development groups are also urgently required. Candidates should have practical experience in the development of electronic devices together with a sound basic technical knowledge preferably equivalent to Ordinary National Certificate standard in electrical engineering or physics. The above posts come within the Company's pension scheme and offer permanent employment with good prospects. Salaries are in accordance with age, qualifications and experience and in line with current levels. Suitable candidates will be interviewed immediately. Application form from Personnel Officer, Mullard Research Laboratory, Cross Oak Lane, Salfords, Nr. Redhill, Surrey. W 2399

E.M.I. ENGINEERING Development Limited have a number of vacancies for engineers and senior engineers on interesting development work in various electronic engineering projects. The posts are for permanent pensionable staff and offer good prospects. Qualifications: a Degree in Physics or Engineering or equivalent, together with several years' design or specialised experience in the following fields: (a) L.F. Equipment; (b) Television Equipment; (c) Microwave Techniques; (d) Pulse Techniques; (e) Servo Mechanisms; (f) Test Gear Designs; (g) Inspection. Applicants should write giving full details of experience and type of work required, and quote ED/33, to Personnel Department, E.M.I. Engineering Development Ltd., Hayes, Middlesex. W 2446

ENGINEERS or physicists are invited to apply for positions in the following fields of work. (a) Electronic circuitry; (b) Servo-mechanisms; (c) D.C. amplifiers; (d) Micro-wave aerials and transmitters; and (e) Test gear for field trials. Work will be in experimental research and development teams at Stanmore (Middlesex). Preference will be given to men with some experience and good qualifications. Apply to the Staff Manager (Ref. GBLC/421) Research Laboratories of The General Electric Co., Ltd., North Wembley, Middlesex, giving age and record. W 2449

ENGLISH ELECTRIC VALVE CO. LIMITED, Chelmsford, have vacancies for young engineers to work on radio valve design and development. Applicants should be of Degree standard.

Whilst experience of this type of work is desirable, it is not essential and otherwise suitable candidates will be considered. Write giving full details quoting Ref. 497D, to Central Personnel Services, English Electric Co., Ltd., 24/30 Gillingham Street, London, S.W.1. W 2343

FERRANTI LIMITED, Edinburgh, have staff vacancies for Engineers or Physicists to work on the development of special valves to operate at microwave frequencies. Experience in this type of work is not essential but applicants should have an Honours Degree in Physics or Engineering. (1) Senior Engineers, with experience in charge of a development group, salary range according to qualifications and experience £1,000 to £1,600 per annum. (2) Development Engineers, salary £500 upwards per annum according to qualifications and any previous responsibility in development work. These positions carry good prospects for advancement in an expanding organisation. Contributory Pension Scheme. Apply quoting "VPL/E," giving full details of training, qualifications and experience to the Personnel Officer, Ferranti Limited, Ferry Road, Edinburgh. W 2378

H.F. HEATING ENGINEERS are required by the English Electric Company for their Industrial Electronics Department. These vacancies are for junior and senior Engineers with good experience of valve type H.F. Heaters. These are permanent and progressive appointments offering excellent opportunities for qualified engineers or those with sound practical experience of this class of work. Interviews can be arranged for Saturday mornings. Write giving full details and quoting Ref. 357C, to Central Personnel Services, English Electric Company, 24/30 Gillingham Street, London, S.W.1. W 2400

INDUSTRIAL instrument manufacturers in North-West London require Electrical Engineers and Electro-Mechanical Engineers for the Development and Engineering Division: (a) Senior Candidate, age 28-35, with high scientific qualifications and outstanding organising ability, capable of directing team of engineers; (b) Electrical or Electro-Mechanical Engineers, age 20-24, for design and development of electrical and mechanical components and instruments. Write, giving detailed particulars of education, experience and qualifications, and present salary to Box No. W 2437.

INSPECTORS Mechanical and Electronic. Good rates of pay, plus staff appointments in cases of exceptional ability. Canteen facilities, social club and congenial working conditions. Apply in writing or personally to Personnel Officer, Decca Radar Co. Limited, Shannon Corner, Kingston-by-Pass, New Malden, Surrey. W 2320

JUNIOR ENGINEERS required to assist in Research Development and Design of Electronic Calculating Devices. Some experience of Electronic Pulses and Counting Technique desirable but not essential. Applicants must have some experience of Research Development of Design Works in the Technical field. Qualifications: Degree in Physics or Engineering, Higher National Certificate or equivalent. Apply giving full particulars to the Labour Manager, Messrs. Vickers-Armstrongs Limited, Crayford, Kent. W 2373

JUNIOR INSTRUMENT ENGINEER, Higher National Certificate or equivalent. For electrical instrumentation schemes including remote indication and control. Write fully stating age and particulars of posts held to Box E.E. 631, at 191 Gresham House, E.C.2. W 2368

LABORATORY ASSISTANT required for Instrument Section. Previous experience in repairing, adjusting and calibrating both indicating and electronic instruments and test gear is essential. Higher National Certificate or equivalent qualifications would be an advantage, but is not essential. Apply in writing giving full details of training and experience to the Staff Manager (Ref. G BLC/G214) Research Laboratories of the General Electric Co. Ltd., North Wembley, Middlesex. W 2416

LADY TECHNOLOGIST or Graduate required for Engineering Test Department S.E. London, to be responsible for technical records. Ability to undertake technical investigations under guidance; knowledge of typing an advantage but not essential. A lady engineering student is also required. Write stating salary required, giving qualifications and previous experience, if any, to Box E.C.651, at 191 Gresham House, E.C.2. W 2374

CLASSIFIED ANNOUNCEMENTS
continued on page 6

EKCO *rack mounted equipment*

For the neat and systematic housing of laboratory equipment for the measurement of radioactivity, Ekco can supply numerous combinations of units mounted in racks or cabinets, with interconnecting leads and mains supply cables cleated in position. Where necessary, cooling fans are incorporated. The equipment can be built up on the unit basis, blank panels being replaced with additional instruments when required. Such an installation has many advantages over the haphazard positioning of units with tangled leads and makeshift connections, which hardly inspire confidence in the results obtained. Ekco rack mounted equipment is indeed a most useful aid to speed and accuracy in research and routine work. Please write for further information.

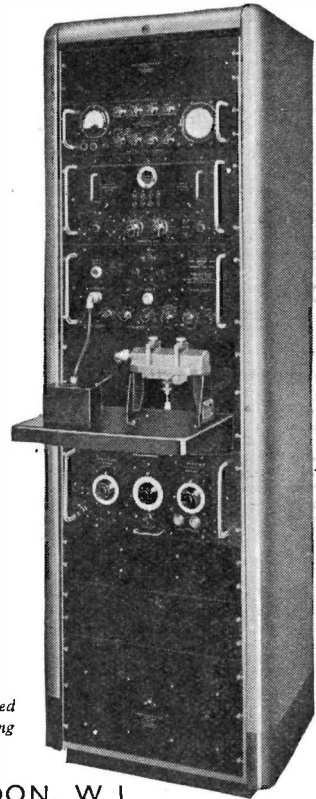

EKCO *electronics*

*Ekco Rack Mounted
Proportional Counting
Equipment*

E. K. COLE LTD. (*Electronics Division*), 5 VIGO STREET, LONDON, W.1

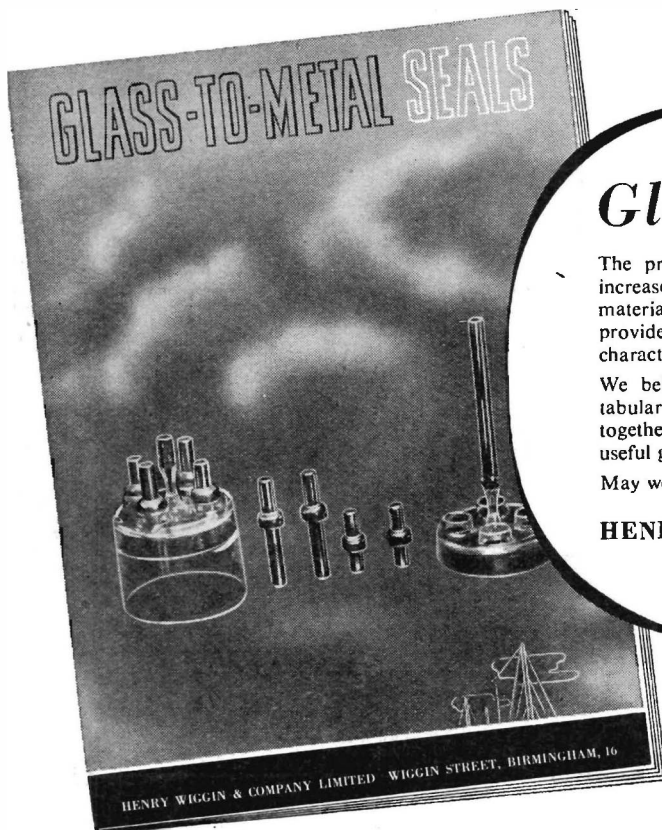

Glass-to-metal Seals

The present abnormal conditions of supply have placed increased emphasis on the correct choice of constructional materials. As an example, the Nilo range of nickel-iron alloys provides a range of compositions each having distinctive characteristics and developed to meet a specific requirement.

We believe that our revised publication, which includes tabular data on the properties of the various grades of alloy, together with examples of their industrial use, will prove a useful guide to the selection of the correct grade of material.

May we send you a copy?

HENRY WIGGIN & COMPANY LIMITED

Wiggin Street, Birmingham 16

36/11/52

SITUATIONS VACANT (Cont'd.)

LIVERPOOL RADIUM INSTITUTE Management Committee. A Technical Officer is required in the Physics Department of the Liverpool Radium Institute. The candidates appointed will be required to assist in developing the technical section now being built up. He should be primarily an instrument maker, should have some knowledge of building and servicing electronic equipment, and should be capable of co-operating in the mechanical aspects of the design of new apparatus. The commencing salary will be £600 per annum. Further details may be obtained from the undersigned, to whom applications with full details of experience and copies of two recent testimonials or names of two referees should be submitted not later than 15th February, 1952. David Bryson, M.B.E., T.D., Secretary to the Management Committee, Myrtle Street, Liverpool, 7. W 2414

LOUDSPEAKER RESEARCH Engineers required. State age and details of experience to Goodmans Industries, Limited, Axiom Works, Wembley. W 2415

MULLARD RESEARCH LABORATORY. Several Draughtsmen are required for work on electronic engineering projects. Some of the vacancies are for senior men of at least HNC standard who have spent a number of years in a Laboratory or Factory design department and are capable of original layout work. Other posts are for Detailing Draughtsmen capable of producing workshop drawings from such layouts. Salaries will be at current levels according to qualifications and experience. Prospects of promotion are good and the posts fall within the Company's Pension Scheme. Application forms Personnel Officer, Mullard Research Laboratory, Cross Oak Lane, Salfords, Nr. Redhill, Surrey. W 2363

MURPHY RADIO Ltd., offer the following vacancies in an expanding programme covering the field of domestic equipment and many branches of Electronic Development: (1) Senior Development Engineers having Degrees in Engineering or Physics with post graduate experience of equipment design who would be capable of leading a development team. (2) Development Engineers with similar academic qualifications having less or no industrial experience. (3) A Specialist Engineer with good academic qualifications having a sound knowledge of components and raw materials used in the Radio industry. This vacancy is only suitable for an applicant who is experienced in Electrical measurements and life testing of components. These posts are permanent and pensionable and offer good opportunities for advancement. Applications giving full details of experience and qualifications should be forwarded to the Personnel Manager, Murphy Radio, Ltd., Welwyn-Garden-City. W 2399

PHYSICISTS AND ELECTRONIC ENGINEERS required for laboratory in Northamptonshire to carry out design of radio and electronic components from new ceramic and magnetic materials. Previous experience desirable. Salary £450-£650 according to qualifications and experience. Box No. W 2052.

PHYSICISTS or Light Current Engineers with knowledge of circuit design and mathematical ability to work on Flight Simulators in connexion with guided weapon development. Degree or H.N.C. essential and previous experience of electro-mechanical and electronic analogue computing desirable. Applications, stating age, technical qualifications and experience, quoting Ref. 862B, should be addressed to Central Personnel Services, English Electric Company Ltd., 24/30 Gillingham Street, London, S.W.1. W 2389

PLANNING and Estimating Engineers required by manufacturers of electronic equipment. Higher National Certificate in Mechanical Engineering preferred, with workshop training in light engineering industry, preferably telephone or electronic, and not less than 2 years' estimating and planning experience. Apply giving full particulars, to: Personnel Officer, Airmec Laboratories Ltd., High Wycombe, Bucks. W 1390

RADIO MECHANIC required for high priority electronic and light mechanical work in equipment laboratory. Previous experience essential. Apply, Personnel Officer, United Insulator Company, Oakcroft Road, Tolworth, Surrey. W 2396

RADIO WIREMEN are required for work at the G.E.C. Stanmore Laboratories. The work involves assembly and wiring of special airborne radio and radar equipment, laboratory test

equipment, etc. Knowledge of techniques used in manufacture of miniature or similar assemblies, including ability to make and install cable forms is essential. These are progressive staff positions with five-day week and good working conditions. Write giving full details of age and experience to the Staff Manager (Ref. G.B.L.C./G/10), Research Laboratories of the General Electric Company Limited, Stanmore Common, Stanmore, Middlesex. W 2418

REQUIRED URGENTLY Junior Electronic Engineer for development of Radio Interference Suppressors and general test room duties, A.I.D. experience very desirable. Single man under 30 having H.N.C. preferred. Apply Aish & Co., Ltd., Vanguard Works, Poo'le. W 2394

RESEARCH DEPARTMENT of engine manufacturers in Home Counties requires engineer with Higher National Certificate or Degree, having basic knowledge of Electronic Circuits and practical familiarity with Electrical Instruments for measuring pressure, strain, vibration, etc. Must have experience in use of Electronics on internal combustion engine development and some knowledge of the organisation of an experimental laboratory. Experience also desirable in some aspects of Cathode Ray, Oscillography, Engine Indication, Strain Gauges, Pyrometry Torsional and Linear Vibration Pickups. Apply stating age, experience and salary required to Personnel Manager. W 2407

RESEARCH and Development Engineers are required by British Telecommunications Research Ltd., a Company associated with The Automatic Telephone & Electric Co., Ltd., and British Insulated Callender's Cables Ltd., for work on long term development projects in the following fields: (a) Wide-band line communication. (b) V.H.F. and U.H.F. radio communication. (c) Electronic Switching and Computing. A number of posts with salaries in the range of £500-£1,000 per annum are available for suitably qualified engineers or physicists with experience in any of the above or allied fields. Further posts are available for technical assistants with salary in the range of £300-£600 according to qualifications and experience. Applications are also invited from Hons. Grads. in physics or electrical engineering who are considering careers in the research and development side of the telecommunications industry. There is a superannuation scheme and the company works a five-day week. Applicants joining early in the year will be eligible for full annual holidays. Application should be made to the Director of Research, British Telecommunications Research Ltd., Taplow Court, Taplow, Bucks, giving age and full details of education, qualifications, experience and approximate salary required. W 2436

SALES MANAGER required by large long-established Engineering Company. Must have first-class technical knowledge, preferably with University Degree in Electrical Engineering. Extensive experience of Electronics essential. Position offers wide scope for really live man possessing initiative and sales ability of high order. Write giving full details of age, education and positions held to Box EE.609, at 191 Gresham House, E.C.2. W 2358

SENIOR AND JUNIOR Electronic Engineers required for development of Guided Missiles and other work of national importance. Good academic qualifications, a thorough knowledge of low frequency electronic circuits including D.C. Amplifiers, and practical design experience of lightweight electronic equipment are desirable. The posts are pensionable, and offer good scope for a man to learn and develop new techniques and advance his position. Apply to Personnel Manager, Sperry Gyroscope Co., Ltd., Great West Road, Brentford, Middlesex, giving full details of age, qualifications and experience and salary required. W 2440

SENIOR AND JUNIOR Laboratory Engineers required for Electro-Acoustic Laboratory in High Wycombe. Must have had experience on miniaturisation and be theoretically qualified to National Certificate for Junior position, and Higher National for Senior position. 5-day week, canteen and usual welfare facilities. Write giving full resumé of experience and salary expected to Box M.3208, Haddons, Salisbury Square, London, E.C.4. W 2403

SENIOR TELEVISION Development Engineer required by well-known Radio and Television manufacturer in London area. Applicant must have a wide experience in development for mass production of modern commercial Radio and Television receivers. A good salary will be paid to a person possessing drive and organising

ability and capable of carrying through projects from development to production stages, under the supervision of The Chief Engineer. Kindly state full particulars of Technical Education and experience to Box No. W 2405.

SERVO DESIGNER, aged 30-40 required, salary £1,000-£1,500 according to experience. First or Second Class Honours Degree in Mathematics, Mechanical or Electrical engineering required but applicant should be well versed in all three branches. Considerable experience required in the design of servo systems preferably for aircraft. The applicant, who will be interviewed in London, will be responsible for the control of development projects comprising electrical and hydraulic servo flying controls. W 2255

SEVERAL ELECTRONIC ENGINEERS or Physicists are required, who have graduated in Physics or Telecommunications and have two or three years radar experience, to take charge of the development of particular sections of a project involving radar. The work includes design of pulse generators, timing wave form oscillators, electronic computers, V.H.F. transmitters, and receivers and servo systems. In addition Technical Assistants are needed with H.N.C. or equivalent qualifications. All the positions available are for work of high interest in a new and expanding field. Applications, which will receive prompt attention should give the fullest details of education and professional experience with appropriate dates. Apply Employment Manager, Vickers-Armstrongs Limited (Aircraft Section), Weybridge, Surrey. W 2271

SPERRY GYROSCOPE Co., Ltd., Great West Road, Brentford, Middlesex, require Electronic Engineers with good academic qualifications and apprenticeship for development work. Experience in one or more of the following desirable: control systems, D.C. amplifiers, computing devices, video circuits, microwave techniques. Apply with full details of age, experience and salary required to the Personnel Manager. W 2421

SPERRY GYROSCOPE Co., Ltd., Great West Road, Brentford, Middlesex, require Electro-Mechanical Engineers with good academic qualifications, apprenticeship, theoretical background and knowledge of production methods for development work. Experience in electrical methods of computation, servo theory and instrument design desirable. Apply with full details of age, experience and salary required to the Personnel Manager. W 2422

SUNVIC CONTROLS LTD. have vacancies in their Harlow Factory for Engineers with sound technical and shop training for design of Industrial, Scientific and Domestic control equipment. Knowledge of High Vacuum technique, Electronics or Instrument design an advantage, but some years' experience on design for manufacture essential. Houses will be allocated to successful applicants. Apply in writing to Chief Engineer, Sunvic Controls Ltd., No. 1 Standard Factory, Harlow, Essex. W 2430

TECHNICAL ASSISTANTS required for interesting Laboratory and Field work connected with Guided Missiles Project. Applicants to be between 20 and 35 years of age with, at least, National Certificate (Electrical) or equivalent. Experience of R.F. technique up to 500 mc. would be an advantage. Full particulars to Box No. W 2191.

TECHNICAL WRITERS (Male or Female) required to edit reports and prepare handbooks for publication. Qualifications: a good general training in electronics with wide practical experience of electronic equipment, preferably including design experience, and with the ability to write clear English. A marked critical faculty for English composition and technical accuracy is required. Several posts are available in all aspects of the following fields: Radar, A.M. & F.M. Communication Equipment, including sound and television receivers, gramophone reproduction and C.R.T. and valve manufacture. Experience in more than one of these fields is preferred. Applicants should write, stating age, salary required, etc., to Personnel Department, (ED/67), E.M.I. Engineering Development Ltd., Hayes, Middlesex. W 2445

TECHNOLOGISTS, Mechanical Engineers. Higher National Certificate or Graduates. 20-30 years, required for permanent appointments Mechanical Test Department, S.E. London.

CLASSIFIED ANNOUNCEMENTS
continued on page 8

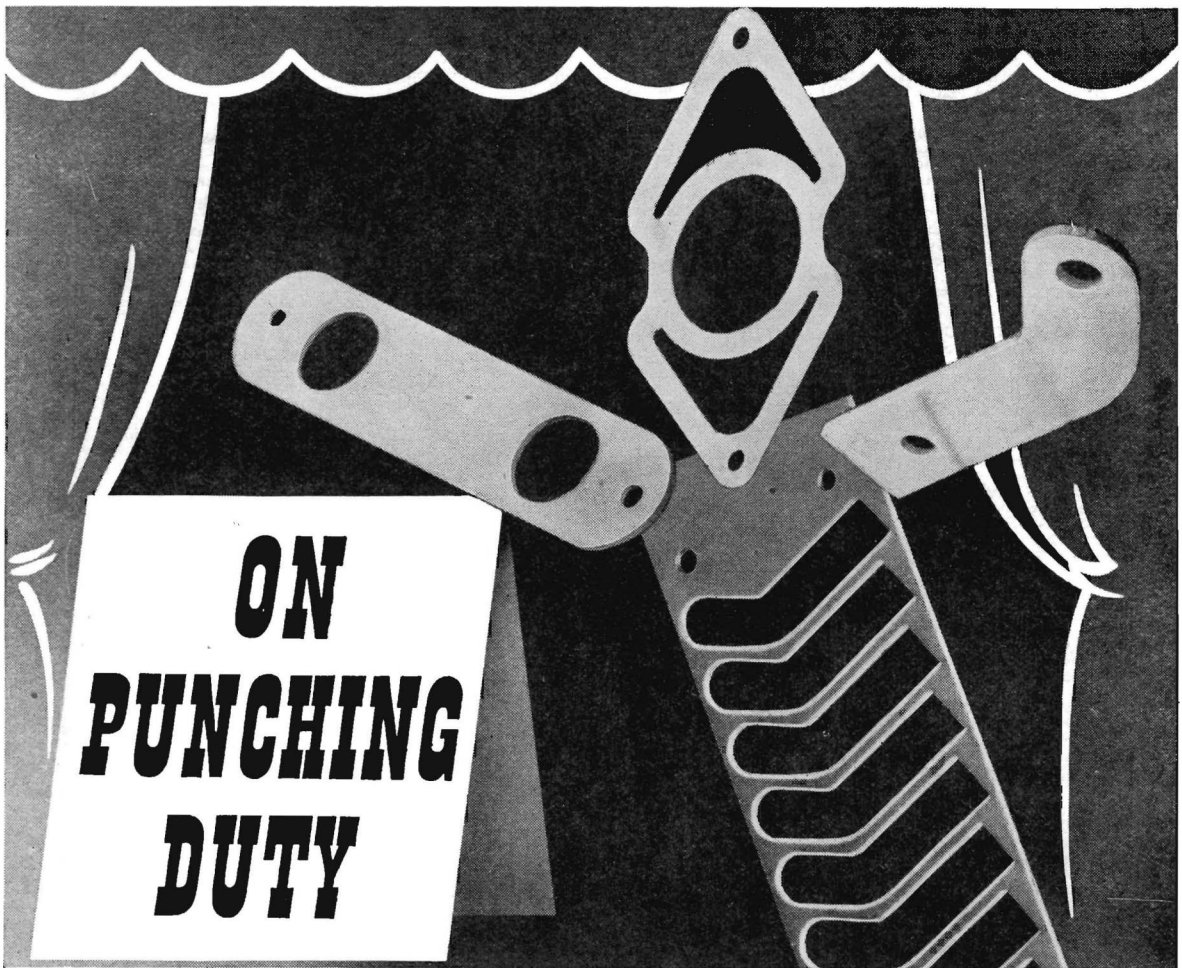

**ON
PUNCHING
DUTY**

Fair grounds exist for asserting in no roundabout manner that punchings in Tufnol are unbeatable in quality. But the uses of Tufnol only begin here, and its real possibilities are unlimited. When hardwood or metal show deficiencies in service, then Tufnol will most likely fill the bill. Structurally strong, light in weight, with

chemical resisting and electrical insulating qualities, unaffected by moisture or climatic exposure—it exhibits a remarkable combination of properties. Added to this is its advantage of being easily and accurately machinable with ordinary workshop facilities. The prefabricated forms—sheets, tubes, rods, bars, angles and channels—reduce production costs: and specially moulded

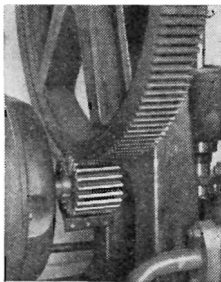

A Tufnol Pinion meshing with a cast-iron wheel. The 18 h.p. motor provides the pump drive for a Hydraulic Accumulator.

shapes or finished parts can be supplied to any specification. Tufnol has put many an extra punch into Britain's export drive!

CONTINUOUS PERFORMANCE

Every day Tufnol is solving fresh problems. Technical publications have already been compiled dealing with the different aspects of Tufnol, but if your enquiry poses a NEW problem, our Technical Staff will work on it with enthusiasm. Why not write TODAY?

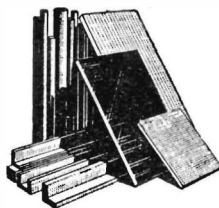

TUFNOL
REGISTERED TRADE MARK
An ELLISON Product

TUFNOL LTD • PERRY BARR • BIRMINGHAM • 22B

254

SITUATIONS VACANT (Cont'd.)

Must be capable of undertaking investigations into performance and analysing of test results of electro mechanical, mechanical and hydraulic mechanisms. Some test gear design from specification data and routine testing involved. Write stating salary required giving qualifications and previous experience to Box E.C.652, at 191 Gresham House, E.C.2. W 2377

TELECOMMUNICATIONS Draughtsmen in a newly formed and quickly expanding division of the Plessey Co., Ltd. Applicants should have experience of line communications or radio communications equipment and should be capable of undertaking work on own responsibility. The positions give the right of entry to the Company's pension fund and life assurance scheme and offer excellent long term opportunities of promotion. State full particulars to Personnel Manager, The Plessey Co. Ltd., Ifford, Essex. W 2426

THE GENERAL ELECTRIC CO. LTD., Brown's Lane, Coventry, have vacancies for Development Engineers, Senior Development Engineers, Mechanical and Electronic, for their Development Laboratories on work of National Importance. Fields include Microwave and Pulse Applications. Salary range £400-£1,200 per annum. Vacancies also exist for specialist Engineers in Component design, valve applications, electro-mechanical devices and small mechanisms. The Company's Laboratories provide excellent working conditions with Social and Welfare facilities. Superannuation Scheme. Assistance with housing in special cases. Apply by letter stating age and experience to The Personnel Manager (Ref. CHC). W 2254

TWO VACANCIES exist for Senior Valve Engineers, in the Research and Development Laboratories of the Standard Telephones & Cables Ltd. Applicants must possess a Degree in Physics or Electrical Engineering and have practical experience in (a) theory and design of microwave valves or waveguide circuits, or (b) electron optics, particularly cathode ray tubes, photo emission and secondary emission. Salary will be according to experience. Applications should be in writing and addressed to the Personnel Manager, Standard Telecommunication Laboratories, Limited, Progress Way, Enfield, Middlesex. W 2427

VACANCIES exist for several graduate physicists or electrical engineers for work in connexion with electrical and electronic instruments and for extended research programme on thermionic emission. Some knowledge of vacuum physics would be an advantage for the latter post but otherwise experience is not essential. Applications will be considered for ages between 20 and 30 with salaries dependent upon qualifications and experience. British Scientific Instrument Research Association, Southill, Chislehurst, Kent. W 1392

VACANCIES EXIST for men with qualifications in electronic engineering or physics for interesting development work of national importance. These posts are permanent and pensionable. Apply Personnel Department (Ref. 2371), Standard Telephones & Cables Ltd., North Woolwich, E.16. W 2433

WAYNE KERR require several draughtsmen for design and development work on high priority electronic test equipment. The work is interesting and offers considerable scope for men with initiative and design ability. Attractive salaries in excess of the revised A.E.S.I.D. rates will be offered to suitable applicants. Write giving details of past experience to Wayne Kerr Laboratories, Ltd., Sycamore Grove, New Malden, Surrey. W 2423

WAYNE KERR require several engineers for design and development work on electronic equipment. The development programme is varied and ranges from S band oscillators and Q meters to H.F. Signal Generators, Audio Tone Sources, and precision D.C. measuring equipment. There is a particular need for a senior engineer with a good Degree and background of practical achievement, who will take a leading part in the laboratory and who will qualify for a salary in the range £900-£1,250. The salaries for the remaining posts are in the range £600-£850 depending on qualifications and experience. Write to The Technical Director, Wayne Kerr Laboratories Ltd., Sycamore Grove, New Malden, Surrey. W 2431

SITUATIONS WANTED

ELECTROENCEPHALOGRAPHER trained and experienced male technician recordist seeks hospital appointment where his heart and soul

interest in EEG would be appreciated. Able fully establish a new department and welcomes responsibility. Please write: Box No. W 1400

ENGINEER, A.M.I.Mech.E., age 27, seeks job in South of England. Now occupying responsible commercial position. Sound practical and theoretical training in Mechanical and Electronic engineering, with special interest in electronic instruments. Box No. W 1395.

GRADUATE I.E.E., H.N.C., 29, possessing critical musical faculty; enlightened technical outlook and recording studio experience desires employment where a seasoned musical appreciation would be as essential as up to date technical knowledge. Salary of secondary importance. Box No. W 1396.

LIBRARIAN, technical, retired 60, abstracting, classifying, patent work, seeks suitable post. Box No. W 1398.

SERVICE

CABINET WORK Consold T.V. Cabinets—baffles to your own design measurements and finish. No requirement too large or too small. Real "Tailor Made" industrial or private work undertaken by our craftsmen or mass produced for the trade. Write or phone Ashdown, 98 Hertford Road, N.9. Tot. 2621. W 1395

GLASSBLOWING repetition and scientific, by Hall Drysdale & Co. Ltd., of 58 Commerce Road, Wood Green, London, N.22. Phone BOWes Park 7221-2. W 109

YOUR COPIES BOUND, handsome volumes imit. Blue Leather, Gold Lettering. 10s. 6d. each, post free, C.W.O. Jerome Alcock, Chedale, Stoke-on-Trent. W 1384

TRANSFORMERS and all types of electrical winding to specification and highest standards, large or small quantities, good deliveries, quotations by return. Wilflo Products, 230-254 Brand Street, Glasgow, S.W.1. W 2387

TECHNICAL TRANSLATIONS all radio material incl. H/F, Eng-French, French-Eng., also German and Dutch. Bernet, 27, bis, Boulevard de St. Julien, Bellevue, Seine-et-Oise, France. W 1391

FOR SALE

AMERICA'S famous magazine Audio Engineering, 1 year subscription 28s. 6d.; specimen copies 3s. each. Send for our free booklet quoting all others; Radio Electronics, Radio and Tele. News, etc. Willen Limited (Dept. 9), 101 Fleet Street, London, E.C.4. W 108

FOR SALE. General Radio UHF Signal Generator, improved type 804-V. Best offer to United Insulator Co., Oakcroft Road, Tolworth, Surrey. W 2425

MAGSLIPS at 1/10th to 1/20 of list prices. Huge stocks. Please state requirements. K. Logan, Westalley, Hitchin, Herts. W 116

MINIATURE STEEL BALLS and Ball Bearings Swiss and German Precision Work. Quick delivery. Distributors: Insley (London) Limited, 119 Oxford Street, London, W.1. Tel: Gerrard 8104 and 2730. W 143

MERCURY SWITCHES are made by Hall Drysdale & Co. Ltd., of 58 Commerce Road, Wood Green, London, N.22. Phone BOWes Park 7221-2. W 107

PURE BERYLLIUM FOIL 0.005-in. thick: Elgar Trading Limited, 240 High Street, London, N.W.10. W 141

RESEARCH into the use of servo-control equipment in industry is rapidly expanding and it will be of interest to manufacturers to hear that we are in a position to offer for immediate delivery many types of Magslip and Selsyn elements at a considerable reduction on current prices. Among the many applications of Magslips we may mention use as a flexible shaft, for remote indication, remote power control, remote handling (e.g. of radioactive materials) and electrical computation. Our large stocks include Magslip transmitters, receivers, resolvers, hunters, follow through transmitters and many other special types. Linear A.R.L. Ipos No. 1 Mk. 1 are also available. All our equipment is guaranteed. Home and export enquiries invited. Illustrated brochure and price list from: Servotronic Sales, Abbey Road, Belvedere, Kent. Telephone Erith 2479. W 2447

TOROIDAL COILS wound, and latest potted inductors to close limits. Bel Sound Products Co., Marlborough Yard, Archway, N.19. W 139

WEBB'S 1948 Radio Map of the World, new multi-colour printing with up-to-date call signs and fresh information; on heavy art paper, 4s. 6d., post 6d. On linen on rollers, 11s. 6d., post 9d. W 102

BUSINESS OPPORTUNITIES

OPPORTUNITY arises to acquire a working interest or Directorship in a progressive Company of Photographic and Electronic Equipment Manufacturers in Surrey. Capital needed, approximately £2,000. Bona fide enquiries to J. W. Cutler, F.A.C.C.A., F.T.I.I., Certified Accountant, 164, Banstead Road, Carshalton, Surrey. W 1401

PATENT

IT IS DESIRED to secure the full commercial development in the United Kingdom of British Patent No. 594,799 which relates to "Telemetering Systems" either by way of the grant of licences or otherwise on terms acceptable to the Patentee. Interested parties desiring copies of the patent specifications should apply to Stevens, Langer, Parry & Rollinson, 5 to 9, Quality Court, Chancery Lane, London, W.C.2. W 2409

EDUCATIONAL

FREE! Brochure giving details of courses in Electrical Engineering and Electronics, covering A.M.Brit.I.R.E., City and Guilds, etc. Train with the Postal Training College operated by an Industrial Organisation. Moderate fees. E.M.I. Institutes, Postal Division, Dept. E.E.29, 43 Grove Park Road, London, W.4. Chiswick 4417 (Associate of H.M.V.). W 2338

CITY & GUILDS (Electrical, etc.) on "No Pass—No Fee" terms. Over 95 per cent successes. For full details of modern courses in all branches of Electrical Technology send for our 144-page handbook—Free and post free. B.I.E.T. (Dept. 337C), 17 Stratford Place, London, W.1. W 142



Partridge News

TRANSFORMERS
from 5VA to 100kVA
(POWER OR A.F.)
available for

EARLY DELIVERY

★

Facilities are now available for prompt delivery of "standard" or "to specification" models. Each type is backed by a specialist design and production service of nearly twenty years' standing. Insist on 'PARTRIDGE'—and be sure.

As supplied to

B.E.A. ● National Coal Board
● British Railways ● Royal Aircraft Establishment ● and other Government Departments.

PARTRIDGE
TRANSFORMERS LTD

ROEBUCK ROAD, KINGSTON-BY-PASS
TOLWORTH, SURREY
Telephone ELMbridge 6737



the impress of

Quality

Without the ageless art of Ceramics, the present-day skills of radio and television would not function, the electronic age of tomorrow be stillborn. For the technocracy of the future must still rely on Low Loss Ceramics, die made to fine limits, for insulation incontestable.

An impress of Quality, by which the products of Taylor Tunncliff will always be recognised.



Taylor Tunncliff & Co Ltd.

Low Loss Ceramics

Head Office EASTWOOD · HANLEY · STAFFS

Telephone : Stoke-on-Trent 5272-4

London Office : 125 HIGH HOLBORN W.C.1 Telephone : HOLborn 1951/2

magnetic materials

PERMALLOYS for miniaturisation and the conservation of raw materials

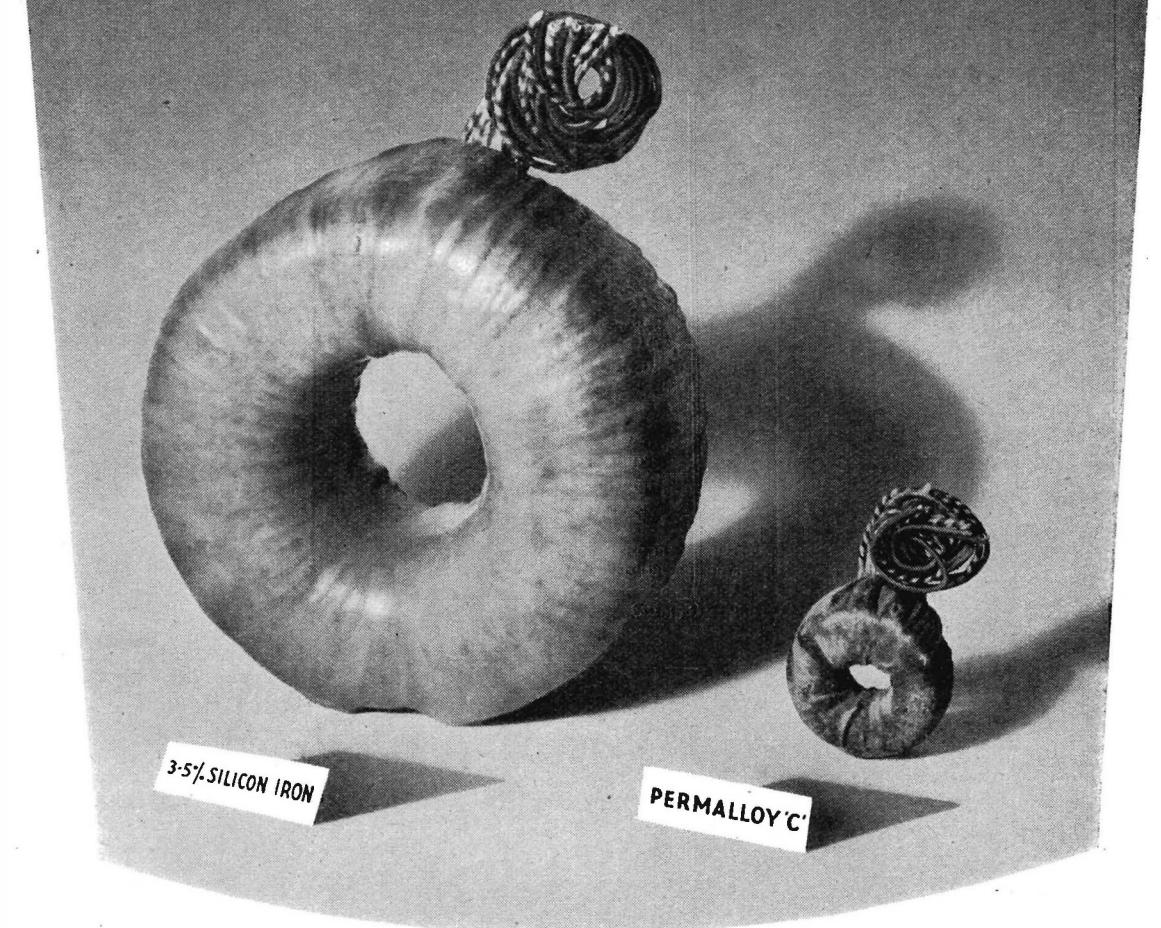

Comparison of the volumes of these two coils, 264 c.c. and 6.4 c.c. respectively, will underline the advantages of *Standard* Permalloys which have played so great a part in the technique of coil miniaturization and in the conservation of raw materials . . . 40 Permalloy 'C' Coils could be used in the same space as one Silicon-Iron coil.

The relative characteristics of these two coils are as follows :

TEST	3.5% SILICON IRON	PERMALLOY 'C'
Nominal impedance ratio	600 : 600 ohms	600 : 600 ohms
D.C. resist. of primary winding	42 ohms	39 ohms
" " " secondary winding	48 ohms	48 ohms
Self inductance of primary winding at 300 c/s—1 volt drop	3.0 Henries	6.5 Henries
Corresponding flux density	13.5 Gauss	336 Gauss
Leakage inductance	12.5 millihenries	0.7 millihenries
WEIGHT OF COIL	774 GRAMS	19.8 GRAMS

Standard Telephones and Cables Limited TELEPHONE LINE DIVISION

Registered Office : Connaught House, Aldwych, London, W.C.2

NORTH WOOLWICH, LONDON, E.16 · ALBERT Dock 1401

Towards peak production . . .

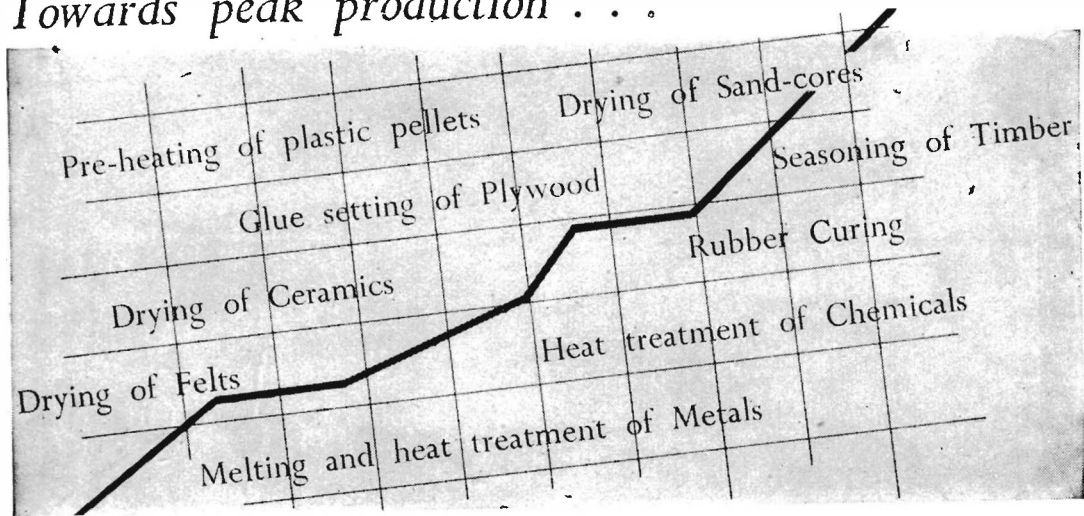

M-V High Frequency Heating shows the way

The application of electronics to industry has helped to solve many production problems. One of the latest electronic aids, the Metrovick High Frequency Heater, has further increased the output potential. It can be successfully applied to numerous industrial processes, and is rapid, efficient and simple in operation. This heater takes up far less space than normal heating systems, and its speed and efficiency will result in the original outlay being quickly recovered.

M-V Engineers will be pleased to send full details of the wide range of applications and to discuss associated problems, such as industrial Induction Heating.

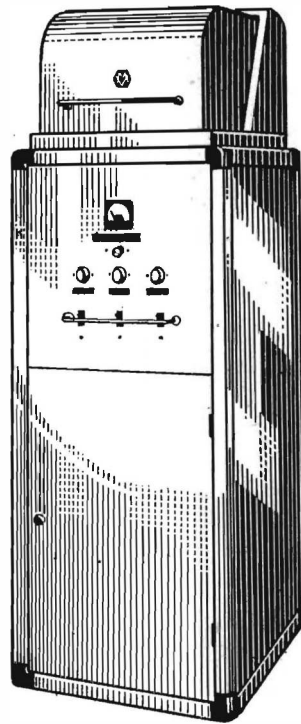

METROPOLITAN-VICKERS ELECTRICAL CO. LTD., TRAFFORD PARK, MANCHESTER 17

METROVICK

for more efficient Industrial Heating

R/E 001



With aircraft spanning the globe daily it is essential that they should be able to obtain instantaneous contact with aircraft carriers, weather ships and other marine traffic for weather reports and information which helps to keep them safely on their assigned routes.

That is why more and more G.E.C. Quartz Crystal Units are being used by aircraft and ships.

Only reliable components are safe and good enough for their radio equipment on which the lives of their passengers and crews may depend.

Write for list QC 5012 (R)

SALFORD ELECTRICAL INSTRUMENTS LTD · SALFORD 3 · LANCs
A SUBSIDIARY OF THE GENERAL ELECTRIC CO. LTD. OF ENGLAND

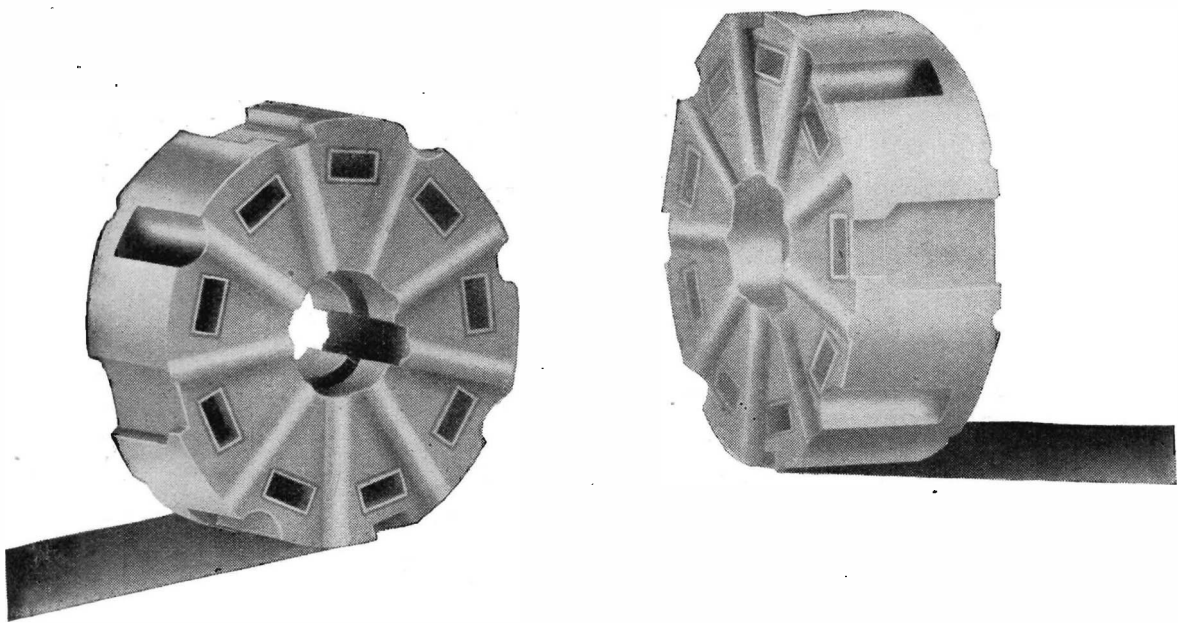

**from every
point of view**

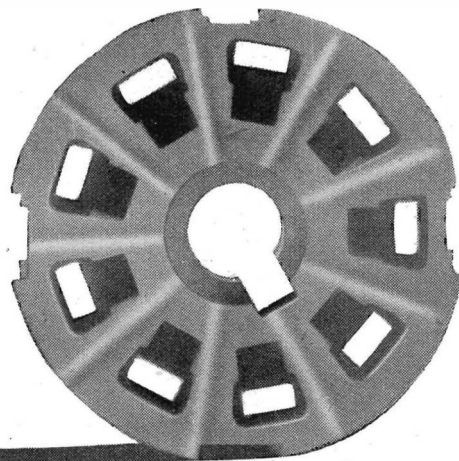

Frequentite is the most suitable insulating material for all high frequency applications. Seventeen years ago we introduced the first British-made low-loss ceramic, and consultation with us before finalising the design of new components is a wise precaution.

STEATITE & PORCELAIN PRODUCTS LTD.

Head Office: Stourport-on-Severn, Worcestershire. Telephone: Stourport 111. Telegrams: Steatite, Stourport



S.P.67



The entire transmitting
equipment for Holme Moss is
supplied by **MARCONI**

Stacked Dipole High-Gain Omni-Direction Aerial Array
Aerial Feeder System · 12 kW Sound Transmitter · 45 kW Vision
Transmitter · Common Vision/Sound Combining Unit
High Power and Low Power Control Desks · 5 kW Medium Power
Vision Transmitter · 2 kW Medium Power Sound Transmitter

Put your name on our mailing list

for **TECHNIQUE**

A JOURNAL OF INSTRUMENT ENGINEERING

AVAILABLE FREE OF CHARGE

- Resistors
- Inductors
- Capacitors
- Attenuators
- Oscillators
- pH Meters
- Tuning Forks
- A.C. Bridges
- Key Switches
- Stud Switches
- Phonic Motors
- Galvanometers
- Control Knobs
- Standard Cells
- Wave Analysers
- Transformers & Chokes
- Instrument Dials
- Resistance Boxes
- Wheatstone Bridges
- Phototelegraphic Equipment
- Servo & Remote Control Equipment

- • • • TO RESEARCH WORKERS
- • • • TO TECHNICIANS
- • • • TO SCIENTISTS
- • • • TO ENGINEERS

and others who are interested in scientific and electronic instruments and their applications

**POST
THIS
COUPON
TODAY**

MUIRHEAD & CO., LTD.
BECKENHAM · KENT · ENGLAND

NAME

MAILING ADDRESS

COMPANY

POSITION

60K

MUIRHEAD & Co., LTD.
PRECISION ELECTRICAL INSTRUMENT MAKERS
BECKENHAM · KENT · ENGLAND

PRECISION
MUIRHEAD
ELECTRICAL INSTRUMENTS

Telephone : BECKENHAM 0041 · Telegrams & Cables : MUIRHEADS ELMERS-END

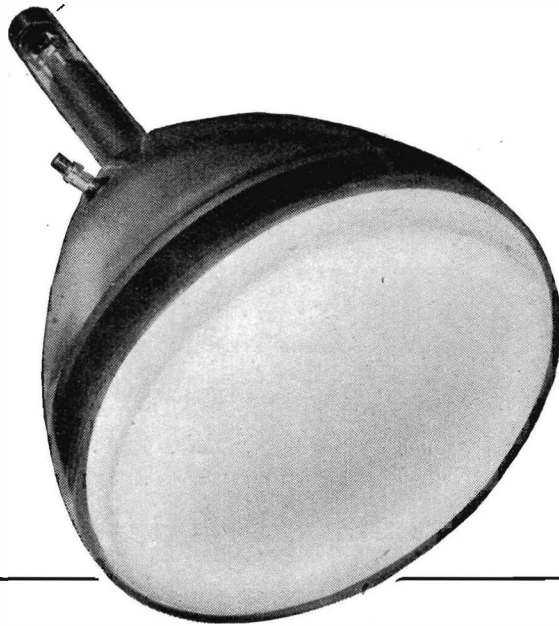

*Type T12/44
12" diameter*

FERRANTI

flat-faced cathode-ray tubes for television

*EXCELLENT PICTURE QUALITY—
THE IDEAL TUBE FOR THE HOME-CONSTRUCTED TELEVISION RECEIVER*

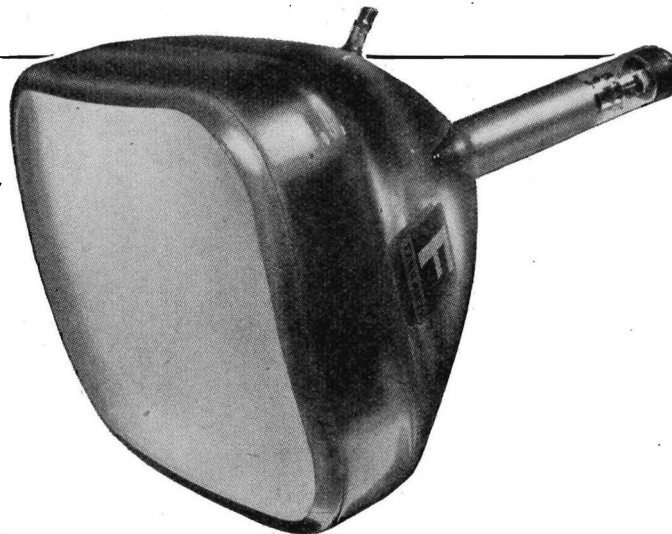

*Type TR14/1
14" diagonal
rectangular tube*

freedom from ion burns

FERRANTI LTD. MOSTON MANCHESTER 10; 36 KINGSWAY LONDON W.C.2



NEW DEVELOPMENT IN FASTENERS For Holding Machine Parts Together TRUARC RETAINING RINGS

THERE'S A
TRUARC RING
FOR EVERY
PURPOSE

*Inverted**

For bearings with large corner radii, uniform shoulder for curved abutting surfaces.



Interlocking

2-piece ring takes heavy thrusts, gives positive lock, secure against high RPMs.

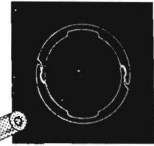
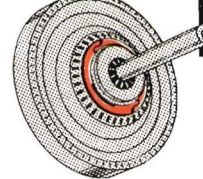

Crescent

Snaps on radially where axial assembly is impossible. No special tools needed.

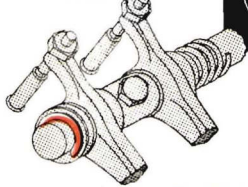

*Bowed**

Takes up end-play resiliently, accommodates accumulated tolerances.

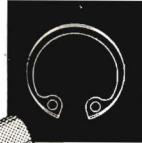
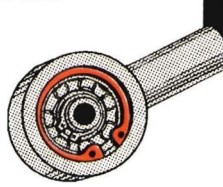

*Bevelled**

Takes up end-play rigidly, accommodates accumulated tolerances.

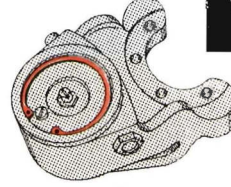

*Circular Self-Locking**

Economical where thrust is moderate—holds fast, yet shaft requires no groove.

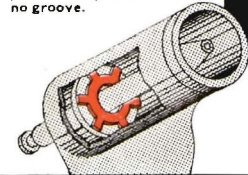

Triangular Self-Locking

Low cost ring for soft shafting materials, requires no groove, secure against vibration.

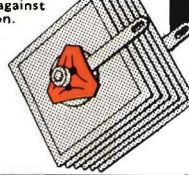

Triangular Nut

Bowed ring body flattens as nut is tightened. Inner thread locks securely with screw thread.

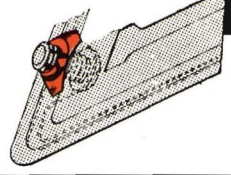

* Available for both internal and external application

Wherever machine parts must be held together with strength and dependability, Truarc Retaining Rings have proved themselves superior in performance to other types of retainers—machined shoulders, nuts, bolts, cotter pins and ordinary snap rings. Quick and easy to assemble, Truarc rings fit securely in grooves. Self-locking types

require no groove. They simplify designs... save materials... minimise skilled labour operations... facilitate maintenance of the finished product. Find out what Truarc Rings can do for you. Send us your problem. We will be glad to suggest a design solution using Truarc Rings, and to send sample rings.

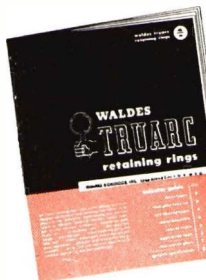

WALDES KOHINOOR, INC., LONG ISLAND CITY 1, NEW YORK, U.S.A.

TRUARC RETAINING RINGS ARE COVERED BY ONE OR MORE OF THE FOLLOWING BRITISH PATENTS: 618,832; 619,078; 621,122; 623,584; 627,059; 618,842 AND OTHER PATENTS PENDING.

Geo. Salter & Co. Ltd.
West Bromwich

- Please send catalogue on Truarc Retaining Rings
 Please send information about obtaining samples

Name _____

Position held _____

Company _____

Business Address _____

EE

M-w.316

Address all enquiries to:—GEO. **SALTER** & CO. LTD., West Bromwich, England.

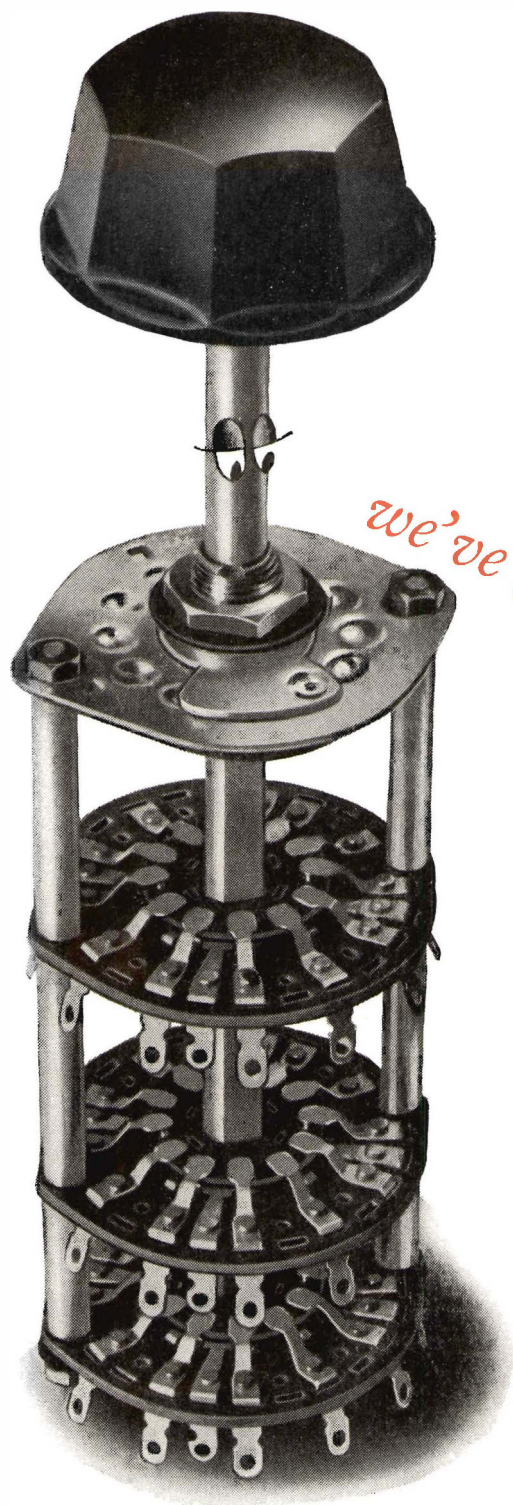

we've got contacts in your business

Walter's have been supplying switches to the radio industry ever since the first radio owner twiddled the first knob and heard the first announcement, "This is 2LO calling. . . ." And that adds up to quite a lot of switches in more than a quarter of a century of switch making.

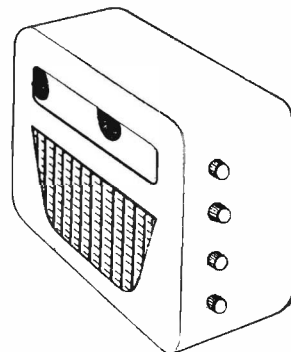

Walter SWITCHES ARE MADE FOR LIFE

WALTER INSTRUMENTS LIMITED Garth Road, Lower Morden, Surrey.

Telephone: Derwent 4421.

Telegrams: Walinst, Morden, Surrey
CRC 55

FREQUENCY

QUARTZ CRYSTALS are widely used to control frequency but whether or not you use crystal standardised equipment you still want to measure frequency, sometimes to only 5% accuracy, sometimes to one part in ten million. Marconi frequency measuring equipment covers these extremes and a wide range of frequencies up to the microwave region, and is found all over the world where frequency is important.

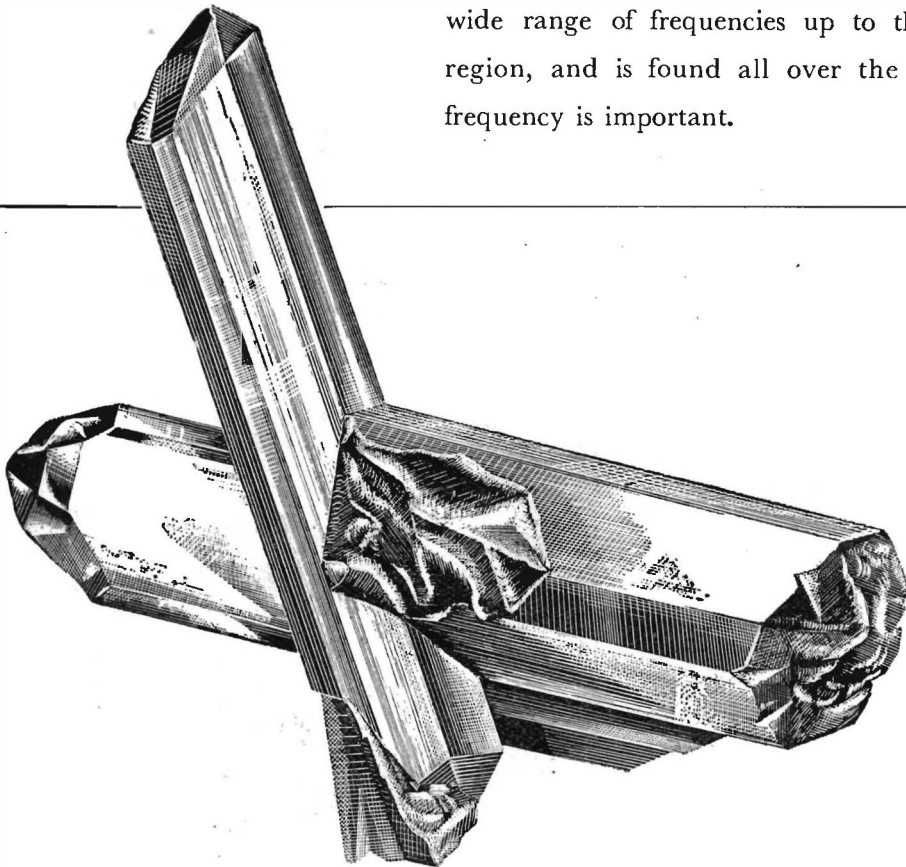

MARCONI instruments

MARCONI INSTRUMENTS LTD · ST ALBANS · HERTS · Telephone: St. Albans 6161/7

Midland Office: 19 The Parade, Leamington Spa. Northern Office: 30 Albion Street, Hull.
Export Office: Marconi House, Strand, London, W.C.2.

For Mutual and Self Inductance measurement...

..... in the range $0.001\mu\text{H}$ to 30mH , the 'CINTEL' Mutual and Self Inductance Bridge will be found unequalled for accuracy and simplicity of use. Also measuring resistance in the range $100\mu\Omega$ to 3000Ω , this bridge is an essential piece of laboratory equipment, full details of which are available on request.



CINEMA-TELEVISION LIMITED

A Company within the J. Arthur Rank Organisation

WORSLEY BRIDGE ROAD · LONDON · SE 2 6

Telephone: H1Ther Green 4600

SALES AND SERVICING AGENTS

F. C. Robinson & Partners Ltd.,
287 Deansgate, Manchester, 3

H. Hawnt & Co., Ltd.,
59 Moor St., Birmingham, 4

Atkins, Robertson & Whiteford Ltd.,
100 Torrisdale Street, Glasgow, S.2



REGISTERED TRADE MARK

Valve book of the year!



CHARACTERISTICS OF RECEIVING VALVES
ELECTRONIC DEVICES · CATHODE RAY TUBES
PHOTO CELLS · GERMANIUM CRYSTALS
COMPARATIVE AND REPLACEMENT TABLES
COMPREHENSIVE REFERENCE to G.E.C. television,
radio and communication equipment with valve combinations.
TYPICAL VALVE CIRCUITS

PRICE

5-

Plus 9d. for postage
and packing.

Apply to your
radio retailer
for your copy.

THE GENERAL ELECTRIC CO. LTD., MAGNET HOUSE, KINGSWAY LONDON, W.C.2.

EVERSHED SPECIAL DUTY F.H.P. MOTORS

TYPICAL D.C. SERVO MOTORS FOR ELECTRONIC CONTROL

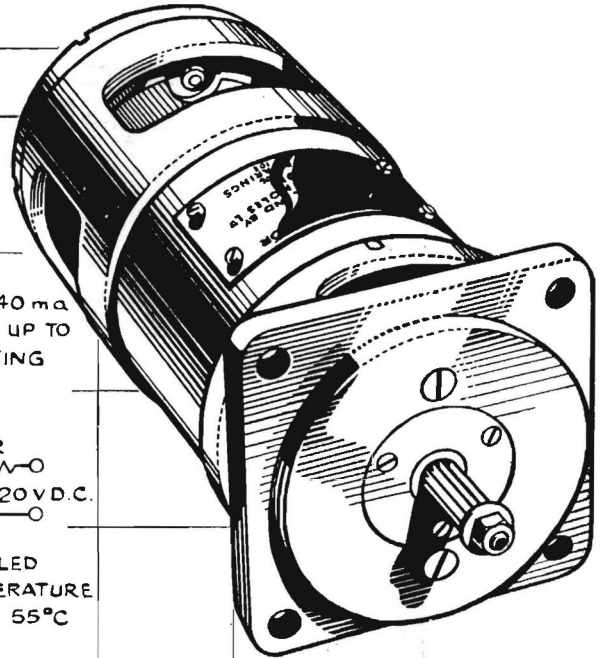
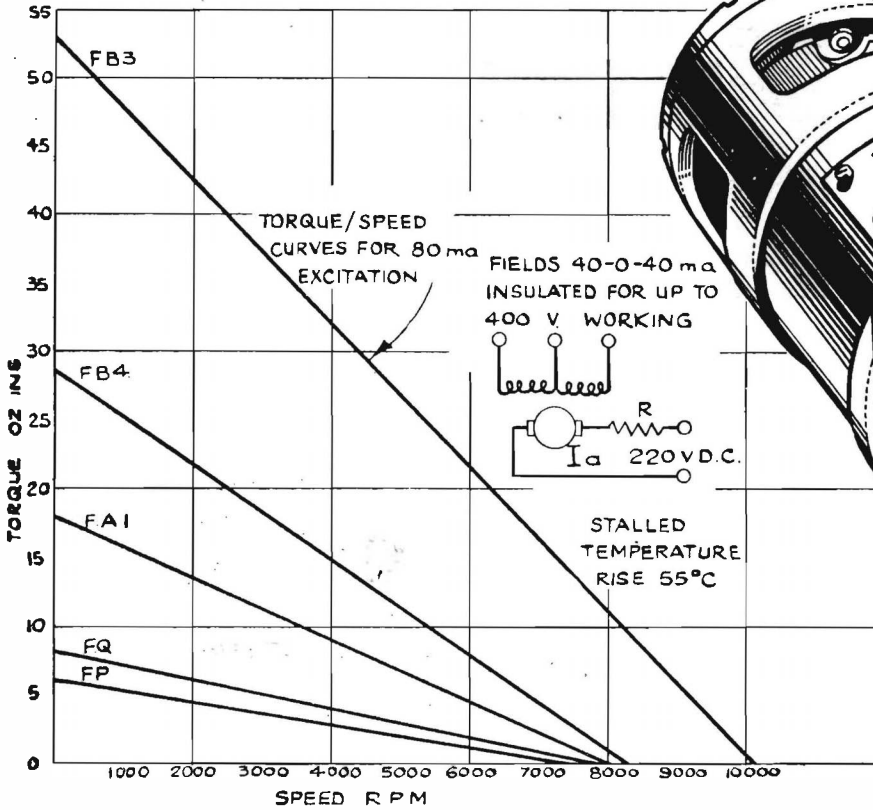

Motors may be supplied with a limited range of alternative Armature and Field Windings.

F.B.3 and F.B.4 Motors, fitted with Integral Field Surge Suppressors.

Shafts Plain or D.P. Spline.

All Motors rated for a stalled temperature rise of 55°C.

Send for the Evershed Small Motors' Data Book, EE 22.

FRAME SIZE	MOMENT OF INERTIA OZ. INS ²	BRUSH & BEARING FRICTION OZ. INS.	I _a AMPS
F.P.	0.5	0.5	0.25
F.Q.	0.75	0.5	0.33
F.A.1	1.8	0.5	0.75
F.B.4	2.2	1.0	1.5
F.B.3	2.2	1.0	3.0

EVERSHED AND VIGNOLES LIMITED

ACTON LANE WORKS · CHISWICK · LONDON · W4

Telephone: Chiswick 3670

Telegrams: Megger, Chisk, London

Cables: Megger, London

5/164

The "Belling-Lee" page for Engineers

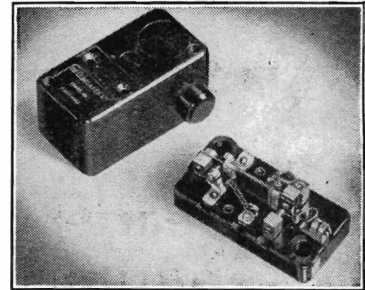
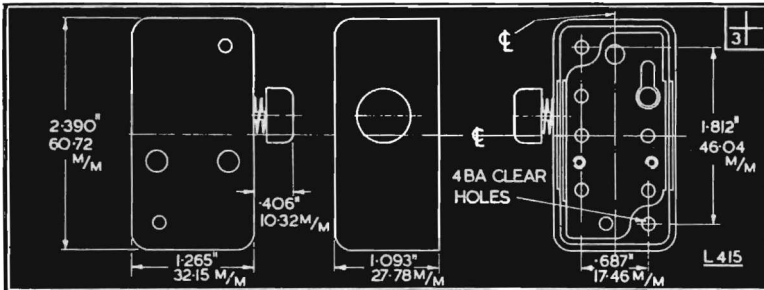

THERMAL CUT-OUTS & DELAY SWITCHES

LIST NUMBERS

L.413	L.423
L.415	L.424
L.417	L.395

Thermal cut-outs and delay switches for use with motor drives, electrical tools, etc.; also for application to non-critical process timing. The type illustrated above (List Number L.415) shows a manual resetting switch.

Where an automatic self-resetting type is required, these are available under List Number L.413 (illustrated below).

Apart from the resetting mechanisms, the general arrangement and electrical characteristics of the two types are similar. Each is fitted with Standard instrument contacts which will break a maximum current of 4 amps. at 250 volts A.C., or 2 amps. at 50 volts D.C.

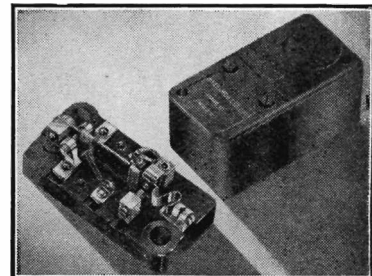
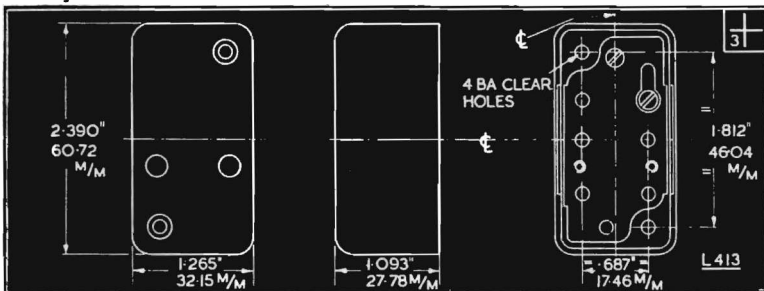

FURTHER DETAILS ON APPLICATION

They can also be supplied to special orders, to break up to 20 amps. at 250 volts A.C. or 5 amps. at 100 volts D.C.

The maximum continuous rating is 10 amps.; normal heater loading for continuous operation, 3-4 watts at any voltage up to 50 volts A.C. or D.C.

For intermittent operation, a heater loading up to 25 watts is permissible. The heater may be in series with main contacts, or independent, being insulated for 250 volts A.C. working potential to bi-metal.

BELLING & LEE LTD
CAMBRIDGE ARTERIAL RD., ENFIELD, MIDDX., ENGLAND



Quarter the thickness of a human hair

The average human hair is $\frac{4}{1000}$ of an inch in thickness (.004" diam. if you'd rather be technical) and our finest enamelled covered wire is only $\frac{1}{1000}$ when insulated with four separate coats of enamel ; one pound of it would measure 316,000 feet, or some 60 miles. Amazingly fine in every way — it must be of course to bear the name Connolly. Let us know if you'd like further details of this or any of our other winding wires.

"The largest manufacturers of fine enamelled wire in the world."



CONNOLLYS (BLACKLEY) LTD., MANCHESTER, 9

Telephone: CHEETHAM HILL 1801

Telegrams: "CONNOLLYS BLACKLEY"

LONDON OFFICE:

34, Norfolk Street,
STRAND W.C.2

BIRMINGHAM OFFICE:

19, Bent Avenue,
QUINTON, 32

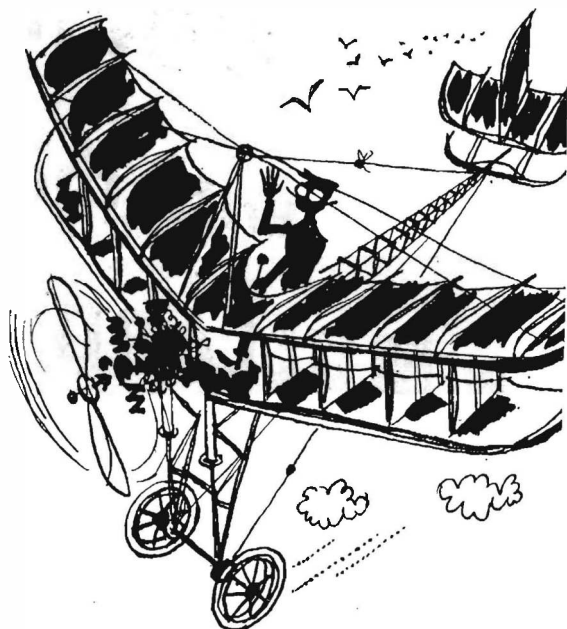

Flying Machine!

It looked like nothing on earth,
 so perhaps it was natural
 that it should rise, if a little
 uncertainly, into the skies.
 Remember those early days of
 aircraft - when men had little
 more than faith...and an idea?
 Parmeko, young then, have
 grown too, in faith, ideas, and
 experience. Parmeko
 transformers in control systems
 and instruments have
 strengthened pilots' hands for
 nearly three decades.

PARMEKO of LEICESTER

Makers of Transformers for the Electronic and Electrical Industries

Electronic Engineering

Incorporating *ELECTRONICS, TELEVISION and SHORT WAVE WORLD*
 Managing Editor, H. G. Foster, M.Sc., M.I.E.E.

Vol. XXIV

FEBRUARY 1952

No. 288

Contents

Commentary	47
The Single Pulse Dekatron	48
By J. R. Acton	
An Electronic Servo Simulator	52
By N. T. van der Walt, B.Sc.	
An Industrial Servo Mechanism	58
By P. H. Briggs, B.Sc.	
Speech Equipment at St. Paul's Cathedral	62
Standardisation of Technical Terms	63
By J. Scott-Taggart, M.I.E.E., M.I.Mech.E., F.Inst.P.	
An Electronic Voltage Stabilizer	65
By C. Morton, B.Sc.	
On the Background of Pulse-Boded Computers (Part 2)	66
By T. J. Rey, M.A., B.Sc., A.M.I.E.E.	
The Activities and Equipment of an Industrial Electronics Laboratory (Part 2)	70
By G. H. Hickling, B.Sc., A.M.I.E.E.	
Piezo-Electric Crystal Constants	76
By W. R. Hinton, A.M.I.E.E.	
Robot Capacitor Grader	77
An Electronic Multiplier	78
By M. J. Somerville, B.Sc.	
A Diaphragm Type Micromanometer	80
By Michael Lorant	
A Further Note on the Marconi Jubilee	81
The Prediction of Audio-Frequency Response No. 2	82
By N. H. Crowhurst, A.M.I.E.E.	
Underwater Television	86
Letters to the Editor	87
Electronic Equipment	88
Book Reviews	90
Notes from the Industry	93
Meetings this Month	94

Published Monthly on the last Friday of the preceding month at
 28 Essex Street, Strand, London, W.C.2.

Phone: CENTRAL 6565. Grams: 'ELECTRONING, ESTRAND, LONDON'

Subscription Rate:
 (Home or Abroad) Post Paid 12 months 26s. or \$3.75 (U.S.)

Classified Advertisements, Page 1
 Index to ADVERTISERS, Page 52



HIGH EFFICIENCY AT V.H.F. with this new MULLARD DOUBLE TETRODE

The new Mullard double-tetrode, QQV06-40, is designed for wide-band operation as an R.F. Amplifier, Modulator, or Frequency Doubler and Tripler.

An improved version of the American 829B, the QQV06-40 has the outstanding advantage of very small output capacitances which permit its use at frequencies up to 500 Mc/s. In addition, the comparatively low inter-electrode inductance of this valve, obtained by the use of

a common box screen grid, enables it to operate at V.H.F. with a higher stability than has yet been attained by valves in this class.

When used in tuned-anode, tuned-grid transmitters, the stability of this double-tetrode is increased even further by the use of internal neutralizing condensers.

Other important design features are:—

1. Direct and short connections between pins and electrodes, causing lower inductance and resistance.
2. No insulating parts (mica or ceramics) between anodes, resulting in lower losses at V.H.F.
3. Screened micas, preventing possible losses due to contaminated mica.

Brief technical information on the QQV06-40 is given here. Full information on this and other valves in the Mullard range will be supplied on request to the address below.

HEATER		
	Series	Parallel
V_h	- 12.6	6.3 V
I_h	- 0.9	1.8 A

CAPACITANCES		
Each section		
C_{gl-all}	-	10.5 $\mu\mu F$
C_{a-all}	-	3.2 $\mu\mu F$
C_{a-gl}	-	<0.08 $\mu\mu F$

Two sections in push-pull		
C_{out}	-	2.1 $\mu\mu F$
C_{in}	-	6.7 $\mu\mu F$

LIMITING VALUES		
V_a max.	-	600 V
P_a max.	-	2 x 20 W
V_{g2} max.	-	250 V
P_{g2} max.	-	2 x 3 W
V_{gl} max.	-	-175 V
P_{gl} max.	-	2 x 1 W
I_k max.	-	2 x 120 mA
f max. (at reduced ratings)	-	486 Mc/s

BASE: B7A

Mullard

MULLARD LTD . COMMUNICATIONS AND INDUSTRIAL VALVE DEPARTMENT
CENTURY HOUSE . SHAFTESBURY AVENUE . LONDON . WC2

MVT 110

Electronic Engineering

Vol. XXIV.

FEBRUARY 1952

No. 288.

Commentary

THE scarcity of adequately trained technologists in this country is a subject that has been occupying the minds of many industrialists and educational authorities since the war. It has come into prominence in the last year or so as the result of visits to the United States by Productivity Teams sponsored by the Anglo-American Council of Productivity.

These teams—some thirty-five in number—have not always been unanimous in their views on the reasons for the greater productivity in America, nor are they convinced that the mere copying of American methods will produce the desired results in this country. It does, however, seem beyond dispute that one of the more important contributing factors is the greater attention paid to the acquisition and application of technical knowledge.

America, developing as an industrial power in an age of technology, has always valued highly the technologist and is able to offer him training facilities perhaps unequalled elsewhere in the world and her lead as an industrial power is due in no small part to such centres as the Carnegie Institute at Pittsburgh, the Drexel Institute of Technology Philadelphia, and the world renowned Massachusetts Institute of Technology.

Lord Portal of Hungerford in his recent Anniversary Address to the Royal Society was at pains to call attention again to the lack of similar facilities here and to the consequent dangers of migration of so many promising young men to the United States for technological training and subsequent employment there.

We in this country have perhaps been longer in appreciating the connexion between productivity and technical knowledge. Our growth as an industrial power over the last hundred years has been more leisurely and the need for the technologist was not so apparent. It is true that technological training has been discussed from time to time by university authorities and technical colleges but no great progress can be said to have been made. The universities have tended to dismiss the problem by regarding it as beyond their scope and to a large extent the technical colleges, while realizing the improved status they could achieve, have found the financial difficulties insurmountable.

The intensive mechanization of industry and the speeding up of production is not a new feature but it has been

accelerated in the post war years by the needs of our economic position. The very suddenness of this transformation has created a number of new problems and not among the least important is the woeful shortage of suitably trained personnel. It is an ironic situation today that the more industry is mechanized and new techniques applied to increase our productivity, the greater becomes the shortage.

Our achievements in fundamental research remain unchallenged but it is only too apparent that in the past we have lacked the ability to put these new discoveries to practical use and to quote again from Lord Portal's address: "We did not think enough about technologists, the developers and designers on whom we depended to turn our new discoveries into practical use, to bridge the gap between fundamental research and production, and to join with industrialists and others in the management of industry and the formation of industrial policy."

In our own branch of industry, some steps have been taken to overcome these difficulties and in October 1945, a Joint Committee on Practical Training in the Electrical Engineering Industry was convened consisting of representatives of the British Electrical and Allied Manufacturers' Association, the Radio Industry Council and the Council of the Institution of Electrical Engineers.

A report on the education and training of electrical technicians was published in October 1950 which proposed extensions to existing systems for the education and practical training of the young apprentice and technician.

It is obvious that in the new schemes the role of the technical college will be an onerous one and the Third Annual Report of the Regional Advisory Council for Higher Technological Education which has recently been issued, makes it clear that the path ahead is beset with many problems.

The Government's policy on technical colleges has been stated in a White Paper and is based largely on suggestions put forward by the National Advisory Council. Increased financial assistance is promised to selected technical colleges and it is proposed to establish a college of technologists, presumably on the lines of the Massachusetts Institute of Technology, which will approve courses in higher technology and make national awards. But we shall have to wait and see to what extent these schemes may be pruned by the economy measures now recommended by the Ministry of Education.

The Single-pulse Dekatron

By J. R. Acton*

This paper gives details of a new type of gas-filled cold-cathode counting tube, differing from the dekatrons previously described¹ in requiring only a single pulse for each complete unit step. The "double pulse" dekatrons, of which the GC10A is the best-known, have found wide acceptance in scalars and computers, and it has been found possible to retain many of the desirable features of the GC10A in the new tubes. In particular the long life, mechanical robustness, and good legibility of the double-pulse dekatrons have been perpetuated in the new single-pulse series. In spite of the generally similar construction, however, the new valve employs a completely different type of transfer mechanism.

The tentative characteristics of a valve in development, the GC10D, are given, and this is followed by some notes on the input and output circuits. These two sections are intended solely to draw attention to some of the broad principles involved in the circuits for the new tubes, and discussions of suitable pulse generators have been excluded as beyond the scope of this paper.

1-transfers and 2-transfers

Fig. 1 represents diagrammatically a cold-cathode gas-filled tube which has three rod-like cathodes and a common anode. If this valve is connected as in Fig. 2(a), and if V_G is at first positive, the glow will invest K_1 . Suppose now that V_G is reduced slowly and made increasingly negative. As is well known, the glow will ultimately tend to transfer to K_2 . This transfer may be made a fairly definite event by means of suitable gas-fillings and spacings. Thus there is very little change visible to the eye until V_G reaches a definite voltage $-\bar{V}$ and then the glow seems to move suddenly to K_2 . The voltage \bar{V} is known as the

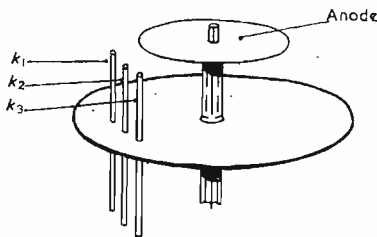

Fig. 1. Arrangement of experimental tube

1-transfer voltage; the process is called a 1-transfer. \bar{V} tends to decrease with increasing glow current.

The result of a 1-transfer is that the glow moves from its original electrode to an immediately adjacent one. There is another type of transfer which is of practical importance, the end result of which is that the glow lodges on an electrode once removed from its original site. This is called a 2-transfer.

If the valve of Fig. 1 is connected as in Fig. 2(b) then with V_G initially positive the glow invests K_1 . But if V_G is now steadily made more negative, at $V_G = -\bar{V}$ the glow tends to transfer to K_2 . As soon as this happens, however, the current flowing through R_K causes the potential of K_2 to rise relative to that of K_3 , and thus a voltage now exists tending to move the glow further on to K_3 . With a suitable resistance R_K it is found that at a value of V_G very little more negative than $-\bar{V}$, the whole glow passes to K_3 . This completes a forward 2-transfer.

If V_G is now made increasingly positive again, the glow stays on K_3 , any tendency to move back on to K_2 being frustrated by the immediate development of a relatively positive voltage on K_2 tending to move the glow back again to K_3 . Only when V_G becomes considerably positive does the glow leap back to K_1 . This event may be termed a back 2-transfer.

Thus a forward 2-transfer occurs much more easily than a back 2-transfer. Measurements on a typical tube showed that with the circuit of Fig. 2(c), the glow would move

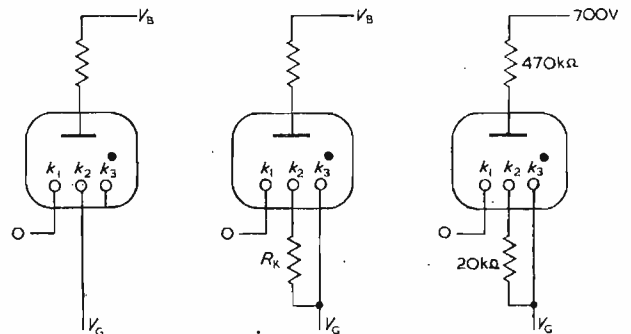

Figs. 2(a), (b) and (c). Circuits for demonstrating 2-transfers

from K_1 to K_3 (forward 2-transfer) when V_G was reduced to -15 volts, and from K_3 to K_1 (back 2-transfer) when V_G was raised to $+62$ volts. This asymmetry of the 2-transfer contrasts strongly with the 1-transfer for which the forward and backward transfer voltages are substantially equal.

The Principle of the Single Pulse Dekatron

The valve consists of forty rod-shaped electrodes arranged around a central anode. Every fourth electrode is connected, making four groups of ten electrodes each intermeshed together in cyclic order (Fig. 3). Thus the general arrangement is similar to the double-pulse dekatron. The groups are designated cathode (K), guide 1 (G_1), guide 2 (G_2), guide 3 (G_3), in clockwise order looking down on the tube from the top. The first guide is connected to the second via a resistor of value of the order of $100k\Omega$, and the third guide is similarly connected to the cathode. These connexions are usually made externally. In the static condition the second guide is returned to a positive voltage so that the glow rests on one of the cathode electrodes.

* Ericsson Research Laboratories, Nottingham.

The current is adjusted so that there is only sufficient glow to cover about half of one electrode. The situation is shown diagrammatically in Fig. 4 where only the electrodes near the glowing electrode are shown.

V_G is initially at +60 volts, and the initial position of the glow is marked by the letter A. If V_G is reduced slowly nothing very much will be observed visually until V_G reaches the value necessary for a 2-transfer. This 2-transfer will be from the point A to the point C on a second guide. Notice that to go to the second guide marked B would require a back 2-transfer. Clearly as the forward 2-transfer requires the lower voltage, it will occur first. The glow will now remain at C even if V_G is still further reduced. To

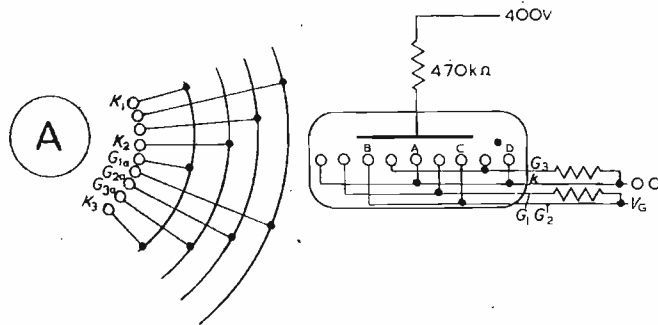

Fig. 3. Cyclic connexions of new dekatron

Fig. 4. Circuit for demonstrating mode of action

move the glow further requires that V_G now be made positive. Again the alternative of transferring forward or backward is offered, but again the condition for forward 2-transfer will be reached well before that for back 2-transfer can be obtained. Hence when V_G reaches a certain positive value a forward 2-transfer occurs and the glow leaves the G_2 and attains the cathode again, but this time at the electrode marked D. The net effect of making V_G negative and restoring it again is that the glow has been moved from one cathode to the next one. Repeating this cycle moves the glow a further step, and so on. Thus for ten negative-going pulses applied to the 40-electrode tube the glow will complete a full circle and return to its original electrode. n pulses ($n < 10$) moves the glow

through $\frac{360 \times n}{10}$ degrees, and thus the number of pulses

received can easily be read off from the position of the glow, as in the case of double pulse dekatrons.

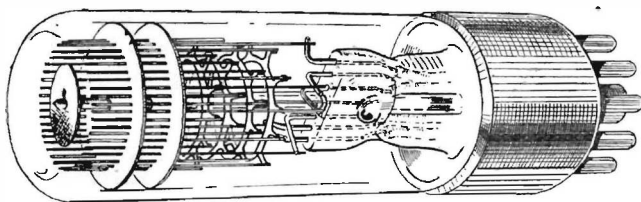

Fig. 5. General view of the GC10D

Effect of Pulse "Rise-Time"

Throughout this discussion of 2-transfers, it has always been specified that the G_2 voltage V_G has been changed "slowly". Suppose now that V_G in Fig. 4 is reduced to a negative potential of, say, -100 volts instantaneously from an initial potential of +100 volts. Because in the static condition the G_3 was returned to zero potential, whereas the G_1 was returned to +100 volts, the current to the G_3 at an instant just before the negative pulse, though very small, is greater than the current to the G_1 . The event being instantaneous, there can be no change in the current distribution on its occurrence, and so at an instant just after the negative pulse, the G_2 electrodes are at -100 volts relative to cathode, resulting in the

alternative of transfer to either of the G_2 electrodes marked B or C. Owing to the higher current flowing to the G_3 between A and B, compared to that flowing to the G_1 between A and C, the glow will tend to transfer backwards to B rather than forward to C. What actually happens is determined largely by the rates of ionization in the various gaps, and usually the direction of transfer is uncertain. Hence a series of negative pulses may result in some forward and some backward transfers. To avoid this uncertainty, it is necessary to specify a certain maximum rate of change of the arithmetical value of G_2 voltages. Fortunately, by suitable design of the tube it is possible to make the permissible maximum rate of change very great, of the order of 100 volts per micro-second.

The GC10D

The construction of the prototypes of the new dekatron type GC10D closely follows that of the GC10A, and the international octal base and bulb size allow the single-pulse dekatron to be used in scalars in the same general way as a GC10A.

Fig. 5 shows the internal assembly and the complete valve. Seven leads are brought out to the pins, these being anode, G_1 , G_2 , G_3 , K, output G_3 , output K. The function of these last two electrodes is to allow an output pulse to be obtained for every tenth input pulse. This is achieved by dividing off two adjacent electrodes, one G_3 electrode and one K electrode from the G_3 and K groups respec-

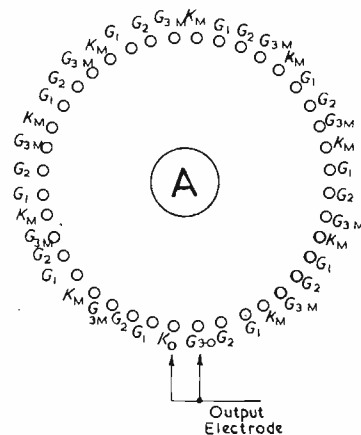

Fig. 6. Detailed arrangement of electrodes

tively, and bringing each of these by separate leads to the pins mentioned above.

Fig. 6 shows the plan view of the electrodes in detail, and this may be compared with Fig. 7, which shows the tentative symbol adopted for this type of valve.

Some details of the tentative specification of the GC10D are as follows.

(a) NOMINAL VALUES

Tube breakdown voltage V_B	300V
Tube maintaining voltage V_M at 0.65mA	180V
Overall length	100mm
Diameter	28.5mm
Base	Small Shell International Octal 8-pin

(b) RECOMMENDED ASSOCIATED VALUES

H.T. battery voltage V_B	400V
Series anode resistance R_A	330kΩ
G_1, G_3 and output G_3 resistances R_G	150kΩ

The mean current with the recommended conditions is about 0.65mA.

(c) ABSOLUTE LIMITS

Pulse duration τ_p	$>25\mu S$
Quiescent period τ_q	$>25\mu S$
Rate of change of G_2 voltage	$<10^8$ volts/sec.
G_2 pulse swing	From $>+40V$ to $<-40V$.

The recommended associated values in section (b) above refer to the circuit of Fig. 8. R_0 has not been specified and the value of R_0 will be discussed in the next section. The conditions in section (c) above are absolute in the sense that if they are violated in no circumstances can the tubes be relied on to perform. They are necessary but not sufficient conditions of satisfactory operation.

By pulse duration τ_p is meant the time elapsing between the time that the G_2 voltage reaches -40 during the falling part of the pulse, and the time the G_2 voltage reaches $+40$ during the rising part of the pulse. Fig. 10 may help to make this definition, and the corresponding one for τ_q , clearer.

From what has been said concerning transfer voltages, there will be a definite minimum value of relative voltage between the cathode and G_2 below which transfer will not occur. This value is, with the recommended conditions, usually about 30 volts, and is never greater than 40 volts. Thus the pulses must carry the G_2 to a potential of at least -40 volts relative to cathode, and they must return to a potential of at least $+40$ volts.

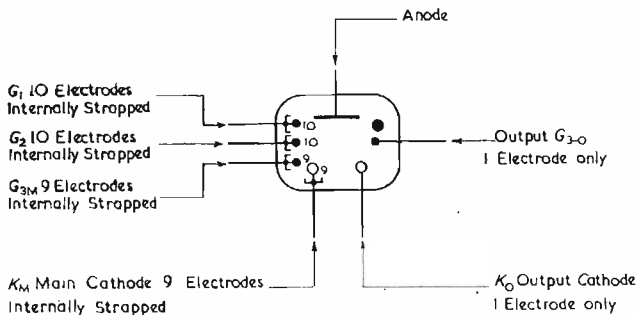

Fig. 7. Tentative signal for single pulse dekatron

If the pulses are such that the potential of the G_2 is carried outside the range of -90 up to $+90$ volts, then the action becomes unreliable at the higher speeds. With the pulses conforming to the limits in (c) of the specification and to the limits of amplitude just given, the prototype GC10D's are reliable at rates of 20,000 I.P.S., irrespective of the general shape of the pulse.

The Output Circuit

Suppose that in the circuit of Fig. 8 the output resistor R_0 is steadily increased (the glow being supposed on the output cathode); the voltage across R_0 will also rise steadily, and this will continue until the potential of the output cathode is greater than that of the G_2 . Any further increase in R_0 brings the risk of a 1-transfer to the adjacent G_1 electrode, and a still further increase may cause a complete 2-transfer to the next G_2 electrode. For this reason alone it would not be advisable to make R_0 very high, but another reason is that when the glow is transferring from the G_2 preceding the output G_3 , to the output G_3 , the apparent resistance in the output G_3 lead is not R_0 but $R_0 + R_G$. Thus if R_0 is as great as $150k\Omega$ the apparent guide resistance for the output G_3 during the first stages of the 2-transfer to the output cathode is just twice the recommended value of $150k\Omega$, and although the guide resistance is not critical this wide deviation does start to cause a deterioration in counting speed. However, a resistor of $82k\Omega$ for R_0 gives an output voltage of about 40 volts, and has only a small effect on the speed of the tube. Since, as already explained, the G_2 potential in the quiescent condition must be between $+40$ and $+90$ volts,

there is no tendency to leave the output cathode until a pulse is applied. However, on account of the increase in equivalent resistance of the output G_3 , it is desirable to raise the quiescent potential to between $+50$ and $+90$ volts.

Drive Circuits

Before discussing a few simple types of drive circuit, it may be worth while recapitulating the relevant data. In the circuit of Fig. 9, pulses must be applied to the input terminal and these are subject to certain restrictions.

- (1) The pulses are to be negative-going, starting from a potential of between $+50$ and $+90$ volts, and descending to a potential of between -40 and -90 volts.
- (2) The pulse and quiescent period durations, as already defined, must be at least $25\mu S$.
- (3) The pulse must not have such a steep rise or fall that the rate of change of potential of the G_2 is arithmetically greater than 10^8 volts/sec.

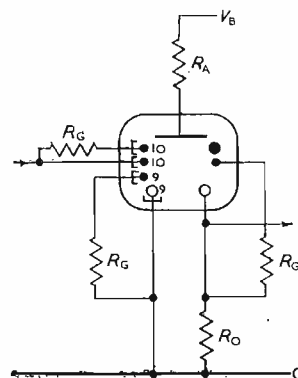

Fig. 8. Circuit referred to in tentative specification

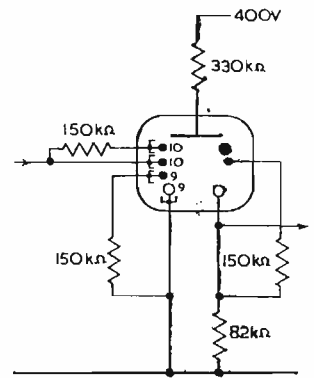

Fig. 9. Circuit showing recommended values

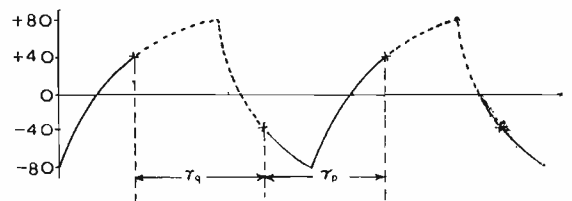

Fig. 10. Illustration of the definitions of τ_q and τ_p

For the purpose of this paper the pulses to be counted will be classified into three groups.

- (1) Regular pulses, with equal mark to space ratio.
- (2) Random or regular, but at least $500\mu S$ between any two pulses, pulse duration not greater than $100\mu S$.
- (3) Random, with pulses not necessarily separated by $500\mu S$ (but separated by at least $25\mu S$).

Pulses of type (1) above include the case of sinewave trains, important in timing units. The circuit of Fig. 11(a) is very suitable. The value of the capacitor C must be chosen so that the time-constant of CR_L is large compared with the period of the input wave train, so that the value of C sets a lower limit to the frequency of waves which can be counted. R_L has been shown as $47k\Omega$ and this value is a compromise between two conflicting considerations. From the point of view of reducing input power, it is desirable to make R_L as large as possible, but owing to the rectifying action of dekatron guides, R_L must be made small compared to R_A , which is $330k\Omega$. The rectifying action is due to the fact that electron current flows to the

positive 400 volt line (via the valve and R_A) when the G_2 is glowing, but no current flows in the reverse direction when the G_2 is not glowing. The result is that the G_2 tends to bias itself positively, by an extra voltage V_z . This voltage gets larger as the ratio of the current via R_A to that via R_L is increased, and with $R_L = 47k\Omega$ is of the order of 20 volts. With $R_L = 1M\Omega$ the valve literally "biases itself to cut-off", the potential on the guide becoming so positive after a few cycles that the negative-going pulses are insufficient to cause transfer to the G_2 . If V_{pp} is the peak-to-peak amplitude of the pulse at the input terminal then, taking into account the fact that $V_z = 0$ when the pulse

-90 volts. It is found that $110 < V_{pp} < 170$ gives completely reliable action.

The pulses in category 3 above are important because the first dekatron of a scaler will frequently receive random pulses, and the usefulness of the scaler will largely be judged by its minimum resolving time. In counting the pulses from, for instance, a nuclear particle detector, a pre-amplifier network is usually introduced to ensure that pulses which follow each other more closely than the minimum quiescent period of the input stage will be suppressed.

The GC10D will count reliably $25\mu S$ pulses, spaced $25\mu S$ apart, provided the upper and lower limits of the pulses are correctly adjusted. Its potential resolving time is thus $50\mu S$, for this is the time between corresponding phases of successive pulses. The input circuit must be devised so that $25\mu S$ pulses are counted correctly, whatever the intervening period between pulses is, provided, of course, that this latter period does not fall below the minimum quiescent period of $25\mu S$. Because of the wide possible variations in mark to space ratio, both the circuits of Figs. 11(a) and 11(b) are useless, since the correct bias on the G_2 stems in the first case from the constant mark to space ratio, and in the second case from the fact that the pulse always commences from the right D.C. potential, a D.C. clamping circuit may be used as in Fig. 12(a). The guide potential rises on the decay of the driving pulse but is held at +50 volts until the next pulse by the rectifier acting as clamp. V_{pp} for such a circuit must be at least 90 volts, and must not exceed 140 volts. To extend the upper limit of voltage a second clamp may be introduced to limit the negative potential of the G_2 to -40 volts, as has been done in Fig. 12(b). This circuit is satisfactory for any amplitude of pulse above 90 volts, so that tolerance on pulse amplitude can be made very large.

It will be seen from the foregoing that the single-pulse dekatron requires only the simplest external circuits. While in no way likely to supplant the double-pulse dekatrons, the single-pulse tubes seem to have advantages in certain applications.

It is hoped that the new tubes will shortly be available in sample quantities and that they will still further widen

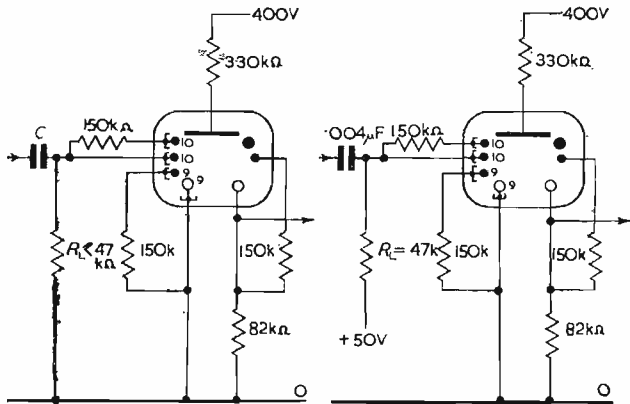

Fig. 11(a). Input circuit for pulses of type 1

Fig. 11(b). Input circuit for pulses of type 2

train starts, and rises to +20 after a few cycles, the conditions for reliable counting at full speed are:

$$\begin{aligned} 50 < V_{pp}/2 + V_z < 90; \\ -40 > 1 - V_{pp}/2 + V_z > -90; \\ 0 < V_z < 20. \end{aligned}$$

It follows that $120 < V_{pp} < 140$. Thus there is a rather tight limit on input amplitude for 20kc/s operation, which can be improved by returning the resistor R_L to -10 volts, so that $-10 < V_z < 10$. This allows V_{pp} to vary between 120 and 160 volts. If speeds of only up to 10kc/s are desired, the upper limit of V_{pp} can be extended considerably, but the lower limit remains fixed for all speeds.

The pulses in category 2 above are of the greatest importance since pulses in the later stages of multi-dekatron scalars are always of this type. This is due to the fact that the first dekatron is accepting pulses at a maximum rate of 20,000 I.P.S. The repetition rate of the output pulses cannot exceed 2,000 I.P.S., therefore, and so the minimum period between the commencement of the two successive pulses is $500\mu S$, whether the input pulses are random or not. The circuit of Fig. 11(a) is modified only in two respects. R_L is returned now to a positive bias of +50 volts, and the time-constant CR_L is no longer made long compared to the reciprocal of the pulse repetition frequency. The purpose of R_L is now to restore the potential of the G_2 to +50 volts before the arrival of the next pulse. If the time-constant CR_L is made about $200\mu S$, this object will be largely achieved. It is desirable that R_L , as before, should be not greater than $47k\Omega$ and that the input pulses should be of length about 50 to $100\mu S$. Although there will be some shortening of the input pulses in the differentiating network, the time-constant is long enough not to reduce the pulse actually applied to the G_2 to below $25\mu S$ duration. The actual circuit is therefore that of Fig. 11(b).

The D.C. restoration is necessarily never complete and at 2,000 I.P.S. the pulses will start from a D.C. voltage of about 70 volts so that a pulse amplitude of at least 120 volts will be required for a transfer to the G_2 . On the other hand the upper limit of pulse amplitude can be made quite large, since for the relatively long pulses ($50-100\mu S$) the action is quite reliable even if the G_2 potential does go below

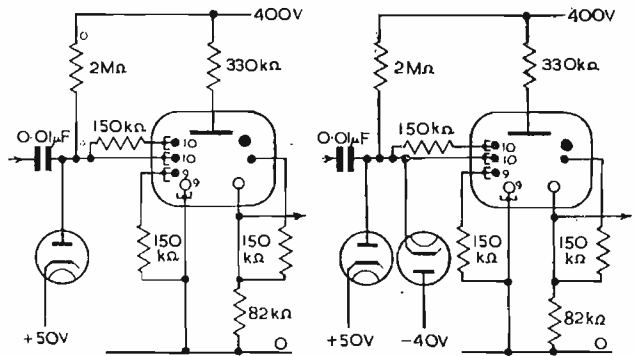

Fig. 12(a). Circuit with single D.C. clamp

Fig. 12(b). Circuit with two D.C. clamps

the field in which cold-cathode counting tubes may usefully replace the traditional hard-valve circuits.

Acknowledgments

The writer would like to thank his colleagues in the Valve Research Laboratory of Ericsson Telephones, Ltd., who have taken part in this development, and Dr. J. H. Mitchell, Head of the Research Laboratories, and Mr. R. C. Bacon, for their interest and encouragement.

The writer would also like to thank the Directors of Ericsson Telephones, Ltd., and the Admiralty, for permission to publish this paper.

REFERENCE

¹BACON, R. C., POLLARD, J. R., The Dekatron. *Elect. Engg.*, X^{II}, 173 (1950).

An Electronic Servo Simulator for Unstable and Open Loop Systems

By N. T. van der Walt, * B.Sc.(Eng.)

This paper describes an electronic instrument for simulating differential equations representing either stable or unstable servo-mechanisms. A repetitive step input is applied to the simulator and the response is viewed directly on a cathode-ray oscilloscope provided with a synchronous time-base. The simulator is made up of a number of "units" in cascade, each of which consists of a feedback amplifier and represents a first order transfer function.

The most interesting new aspect of this instrument is the use of a "clamping" arrangement which enables unstable or highly undamped closed loop systems or certain open loop arrangements to be portrayed on a C.R.O. During the flyback of the time-base which occurs during the return stroke of the step input, the "clamp" operates and in the case of closed loop systems, adequate damping is applied to the simulator to ensure a stable return to datum level. In the case of open loop systems the open loop is changed, by the clamp, into a closed loop of appropriate frequency and damping to ensure a stable return to datum level. The operation of the clamp does not affect the simulator during the forward stroke of the time-base.

TO facilitate the investigation of linear servo-mechanisms or to demonstrate the behaviour of the corresponding differential equations to students, it is convenient to simulate such systems electronically. Parameters of the system are easily variable and the system can be made to operate on any time scale.

In the transient method of servo-mechanism analysis, the chief input or test signal used is the step function (Fig. 2). If this step function is repetitive (i.e., if it is a "square wave") the response of the system to either the positive or negative excursion of the square wave can be viewed on a cathode-ray oscilloscope, provided with a synchronous time-base. The square wave, time-base and a

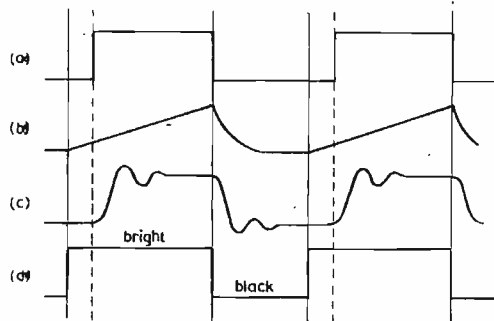

Fig. 1. Relative timing of the input square wave C.R.O. time-base, simulator response and C.R.O. blackout wave-forms

typical response are shown in Fig. 1, curves (a), (b) and (c) with the addition of the blackout wave shown at (d). A display such as Fig. 13 appears on the oscilloscope.

In order that the displayed response may represent the true transient behaviour, it is necessary that the simulator be quiescent at the instant of impulsing. This requirement is frequently met by allowing adequate time during the flyback between useful strokes for the complete dissipation of disturbance due to the unused return stroke of the square wave. This sets a limit on the permissible display in that the response must exhibit a stable return to

datum level, thus ruling out unstable (self oscillatory) systems and most "open loop" arrangements. It is a feature of the present arrangement that the simulator can be modified during flyback by means of a "clamp" operated by the blackout wave so as to yield a damped closed loop response during flyback even when conditions during the forward stroke are oscillatory or tend to infinity. The transient wave may, for example, be an oscillogram as shown in Fig. 3, where a period of oscillatory build up is followed by a period of high damping to reinstate the zero condition. A block diagram of the instrument is shown in Fig. 4.

The system is arranged to operate repetitively at 50c/s. The square wave and time-base generators are of straightforward design and are described in appendices (1) and (2). The simulator proper and the clamping arrangements will now be discussed.

The Simulator

The simulator is shown diagrammatically in Fig. 5. It contains two integrators, representing, in a remote position

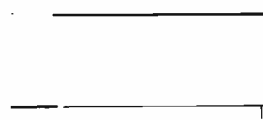

Fig. 2. The input step function

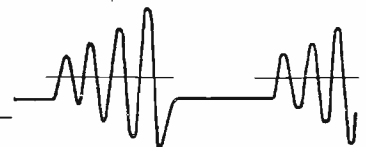

Fig. 3. Damped return to datum level of an unstable oscillating system

control (R.P.C.) system, the integration of torque to speed and speed to position. The "function unit" is adapted to provide various stabilizing configurations and may also introduce an "integral of error" term. "Position" and "velocity" feedbacks are available (θ_0 and θ_v). Since phase reversal occurs in each stage, the phase inverter is necessary to give θ_0 a negative sign with respect to the input signal θ_i . Arrangements with up to three integrators can be simulated and by the introduction of RC circuits higher order "smoothing" terms can be studied.

The simulator is intended for demonstration purposes only and high accuracy was not required so that slight imperfections in the units can be tolerated. All the units

* National Physical Laboratory, Pretoria.

ELECTRONIC EQUIPMENT

A description, compiled from information supplied by the manufacturers, of new components, accessories and test instruments.

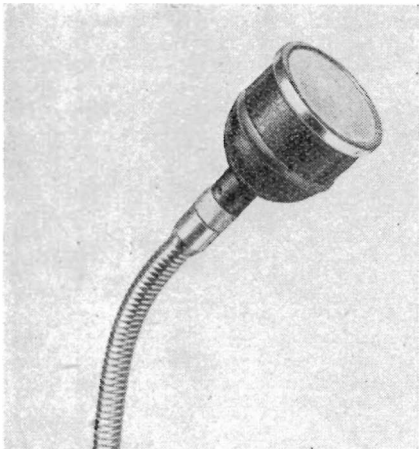

The 4035-A Microphone
(Illustrated above)

THE 4035-A moving-coil microphone is suitable for broadcasting, all public address installations, and out-of-door use, as it is completely weatherproof and not affected by climatic conditions.

The type 4035-A supersedes the 4017 microphone, and is smaller and lighter, weighing $\frac{3}{4}$ lb., with dimensions of $2\frac{1}{2}$ in. diameter by $2\frac{1}{2}$ in. The microphone has an output impedance of 44 to 55 ohms D.C., and an average sensitivity of 74db below one volt/dyne/sq.cm.

The protective screens over the front are similar to those provided on the 4032 hand microphone, and shield the moving coil element from the effects of wind and rain. Constructional features of the 4021-D microphone are incorporated, as they have proved resistant to extremes of tropical and marine atmospheres. The 4035-A becomes slightly directional at frequencies above 2,000c/s. Within a solid angle of $\pm 60^\circ$ from an axis normal to front screen, there is very little variation of high frequency response, but at angles of 90° and more there will be a reduction of 10 to 15db, above 5,000c/s.

It has a low susceptibility to wind noise, and this can be further reduced by as much as 15db by fitting a 4001-A wind-shield.

**Standard Telephones and Cables, Ltd.,
Connaught House,
Aldwych, London, W.C.2.**

Gregory Hygrometers (Illustrated centre)

THE Gregory Hygrometer was developed by Dr. H. Spencer Gregory for humidity measurement in physiology research, but subsequently, in collaboration with Negretti and Zambra, Ltd., adapted for industrial use. It can be used in scientific research, meteorology, air conditioning, etc., as well as for measuring humidity in closed spaces, such as grain silos, tobacco curers, test cabinets, etc.

The Hygrometer does not introduce extra water vapour to disturb conditions,

and it enables an indication to be given or a record made at a considerable distance from the point of measurement. It can also be employed to operate humidity control gear.

The element consists of a specially impregnated fabric carried on platinum-clad electrodes supported by a plastic frame. The impregnated fabric can absorb or give off moisture until it rapidly attains equilibrium with the surrounding atmosphere. The amount of moisture it contains governs its electrical resistance and, with a constant voltage, the current flowing through it. The measurement of the current thus gives a means of showing relative humidity direct, and without reference to tables.

The circuit employs alternating current of standard frequency in order to overcome the effects of polarization. This can be from A.C. mains, or, when D.C. batteries have to be employed, a vibrator pack is introduced so as to

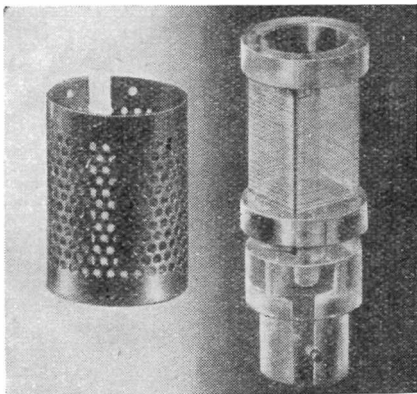

convert the battery output to square waveform alternating current. A stabilizing and reducing unit is necessary to smooth out variations in mains supply voltages.

The instrument has a rapid response to a change of humidity, and elements can be arranged to take up their final reading in 30 seconds. Provided the air is not actually stagnant, there is no need for artificial circulation, as convection currents give rise to sufficient air movement.

The standard element is suitable for most industrial applications, and special elements have been made for research with dimensions suited to the purpose. For the laboratory there is a portable instrument suitable for use on 200/250V A.C. or 12V D.C.

**Negretti and Zambra, Ltd.,
122 Regent Street,
London, W.1.**

Dispersion B.25S

THE Minnesota Mining and Manufacturing Company has produced a magnetic dispersion intended for application to rigid surfaces, such as drums, by spraying or dipping, known as Dispersion

B.25S. Generally, magnetic recording is effected by the use of normally coated tape or film. For special requirements the magnetic medium must be disposed on the surface of a drum, and this dispersion has been developed to meet such a requirement. It will adhere to the rigid surface of a wide variety of metals and plastics—in some cases after the application of a primer—but not to a flexible material such as a thin tape.

**The Minnesota Mining and
Manufacturing Co., 167 Strand,
London, W.C.1.**

Venner Synchronous Motor (Illustrated below)

THE Venner synchronous motor is designed to meet the need for a light-weight and compact motor to generate a very high torque for a low current consumption. The unit can be easily mounted, three fixing holes being provided for this purpose, with the final driving spindle centrally located. This spindle is threaded and fitted with a milled locking nut.

The direction of the rotation can be either clockwise or anti-clockwise according to requirements. The motor is completely self-starting, and is fitted with a uni-directional clutch to prevent its running backwards. Almost any shaft speed can be supplied ranging from one revolution in a few seconds to one revolution per week.

The stator is made from high permeability soft iron, with 30 poles. The coil is wound on a plastic bobbin from enamel covered wire with each layer paper interleaved. The rotor is a cobalt steel magnet of 6 poles, and self-starting is imparted by a soft iron spider. The rotor has a speed of 20 R.P.M. giving the following torque figures: 200V-12.9gm/cm, 230V-13.8gm/cm, and 250V-14.7gm/cm. The unit will operate on 200/250 or 100/125 volts at 50 cycles, while other voltages and frequencies are available to special order. The motor weighs 11oz.

**Venner Time Switches, Ltd.,
Kingston-on-Thames,
New Malden, Surrey.**

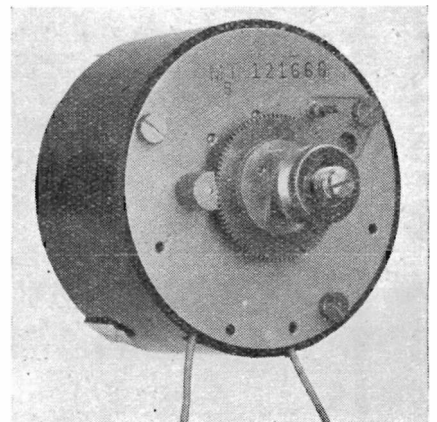

Letters to the Editor

(We do not hold ourselves responsible for the opinions of our correspondents)

Arc We Becoming Slaves to Standardization?

DEAR SIR,—I am interested in the letters on standardization in the December issue of *ELECTRONIC ENGINEERING*. In my opinion, the standardization of terms and abbreviations should be arranged so that:—

- there is no possible doubt as to the meaning of the term or abbreviation;
- it conforms to the standards of good English;
- it is not used in such a way as to result in redundant words;
- it differentiates between a component and its value;
- when it indicates an order of dimensions, it should be quite clear whether that order is smaller or larger than unity;
- it avoids errors resulting from the omission of a period;
- units which are named after a person employ a capital letter whether written *in toto* or as an abbreviation; and
- hybrid terms are not used when a good English term already exists.

If these rules are acceptable:

- The expression A.C. potential, D.C. potential or D.C. current must not be used since they offend against rules (b) and (c). It is better to write alternating or steady (or continuous) potential or current.
- The term voltage is inadmissible since it offends rule (h). The correct word is potential.
- In accordance with rules (e) and (g) we have μA , mA, A but Kc/s and Mc/s. Hence, also μV , V, KV and dB.
- Rule (d) enforces the use of the following terms:—
resistor resistance
inductor inductance
capacitor capacitance

Note that "capacity" is a property of a vessel and not of a capacitor.

Rule (f) means that, in decimal notation, when the value is less than unity, a "0" should be used as a prefix, thus, 0.005 not .005. If the period is omitted as in 0005 no doubt arises as to the meaning but 005 might be .0005 or 0.05 and this is quite indefinite.

The standardization of drawn symbols in circuit diagrams is another matter which requires attention. The number of permitted symbols in some "Schedules of Symbols" is far too great and their form is often unnecessarily complex.

I believe that standardization can be of enormous value provided that the right standards are chosen. The use of standards which cause annoyance or uneasiness will not be readily adopted.

I should also like to point out that laboratory slang and jargon can acquire respectability when no suitable concise terms already exist, but it takes a long time for this to happen. Where such terms or suitable phrases exist, jargon is inadmissible. For example, the expression "a high resistance" is often used,

and I am tempted to ask whether it is a tall resistor or whether it is a normal one on top of a mountain. The correct term is obviously "a high value of resistance."

Engineers are not, in general, good writers because they forget that the reader does not normally know so much about the subject as they do, and hence they are insufficiently explicit. The use of jargon increases the difficulty since the reader expects that the author really means what he has written. Unfortunately, many engineers do not mean anything of the sort.

Yours faithfully,
O. S. PUCKLE,
Beaconsfield, Bucks.

A Linear Staircase Generator

DEAR SIR,

I have read the article on "A Linear Staircase Generator" in the December 1951 issue, and found it most interesting.

There is another and more simple method of producing much the same result which I built up some years ago for testing linearity and half tones in a television receiver.

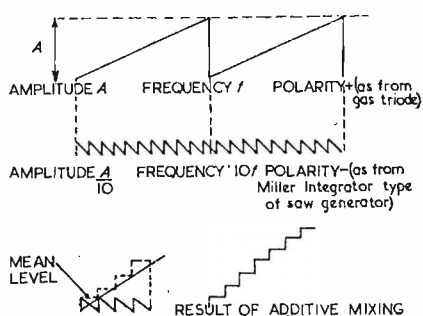

It operates as follows for ten steps: a sawtooth oscillator of amplitude A , frequency f , and positive polarity, is used to synchronize another sawtooth oscillator of amplitude $A/10$ and negative polarity. These waveforms are $A/10$ applied, one to each grid of a double triode having a resistance load common to both anodes. It can be seen from the above diagram that this arithmetic mixing produces a step waveform of the required shape.

Yours faithfully,
R. E. PRICHARD,
Richmond, Surrey.

The author's reply:

DEAR SIR,

We are interested to read Mr. Prichard's letter. His method was known to us, but not used because of a feature which we considered undesirable.

This is that the flatness of each step is not attained automatically as in our method, but depends on a critical adjustment of the relative amplitudes of the two sawtooth waveforms. Thus drifts in the value of certain components will pro-

duce tilting of the steps and this can only be checked with an oscilloscope.

We should like to point out here that a staircase waveform with flat steps applied to a picture monitor gives a picture in which the brightness appears to vary across each step, due to the enhancing of contrast between steps by the eye. Conversely, a staircase waveform set up on a picture monitor to have apparently flat steps, will in general have sloping steps.

We think that if Mr. Prichard's circuit can be made to work reliably with a minimum of valves, then it should lead to an economical and useful piece of apparatus for many purposes. Our somewhat elaborate circuit is justified in view of the special requirement of flat steps which is necessary for telefilm recording measurements.

Yours faithfully,
A. M. SPOONER and F. W. NICHOLLS,
B.B.C. Design Department,
London, W.1.

Mutual Inductance Between Coaxial Coils of Equal Diameter

DEAR SIR,—I note that Dr. Sturley has omitted to mention in the letter appearing in the December, 1951, issue that the results derived from the inductance formula (1) are expressed in microhenries. Although, as Dr. Sturley suggests, this formula is probably well known (it is quoted by F. E. Terman¹), the fact that it is considered necessary to point out that the dimensions of r and l are in inches suggests that for the sake of completeness one ought to specify the unit of inductance used.

This omission does not detract from the value of the information given in the letter, especially for the general reader.

The formula (1) will be recognized as being very similar to the simplified expression for the inductance of single-layer solenoids, due to J. H. Reynier, in which

$$L = \frac{0.2 D^2 N^2}{3.5D + 8l} \mu H$$

where D is the outside diameter in inches.

Yours faithfully,
W. F. P. ENGLAND,
Raynes Park, London, S.W.20.

REFERENCE

¹ TERMAN, F. E., *Radio Engineers' Handbook*, 1st. edition, p. 55. (McGraw-Hill, New York, 1943).

Standardized Abbreviations

DEAR SIR,

H. A. Waters has done well to emphasize the distinction between symbols and abbreviations. In one of his examples, however, he himself obscures the distinction by giving the letter W both as an abbreviation for watts (which is correct by B.S.560) and as a symbol of power (which is not). The BS.560 symbol for power is, appropriately enough, P.

Yours faithfully,
M. G. SCROGGIE, B.Sc., M.I.E.E.,
Bromley, Kent.

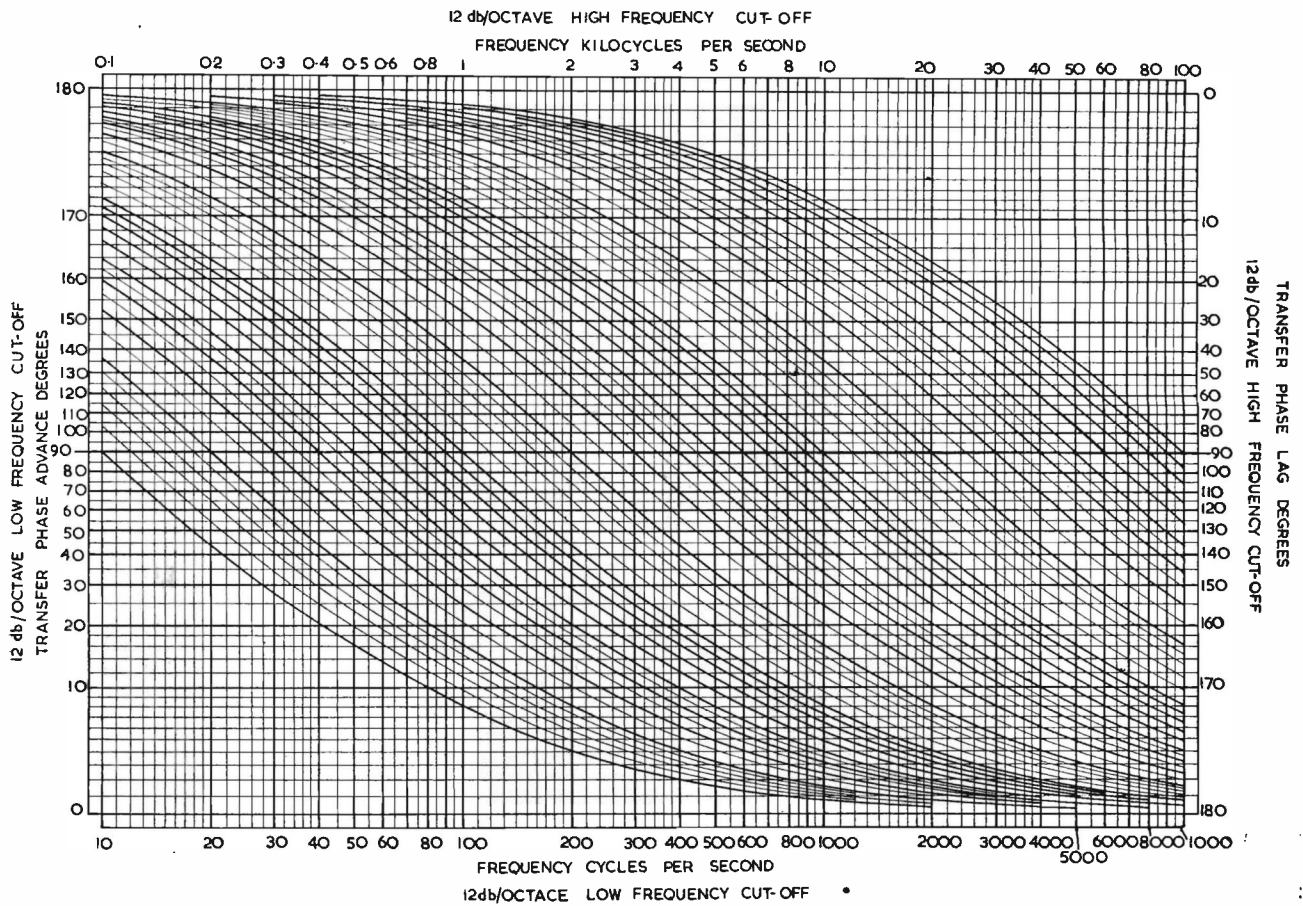

Chart 13. Phase response

Underwater Television

When, last April, the Admiralty requested the help of Marconi's Wireless Telegraph Co. Ltd., in an attempt to find the *Affray* with a Marconi television camera chain, a new field of television applications was opened.

Since then the Marconi Company have been investigating this application and have found that it promises to be of great assistance to various bodies and organizations. Its primary importance is in any type of underwater work where a diver would normally be used, and more particularly when it would be dangerous for a diver to go down.

In the majority of cases a television camera can work for far longer periods under water than a diver could; the extreme sensitivity of the Image Orthicon camera tube can be more effective and accurate than the human eye under water; the camera can go deeper than a diver; and, in matters of interpretation, it allows scientists and experts to see what is below and eliminates the discrepancies which creep into a diver's report.

Another very important advantage is that the television picture received on board a ship from a sunken camera can be filmed and a permanent record obtained.

Apart from the experimental side of underwater television the Marconi equipment has already proved highly successful in the finding of the *Affray* at a depth of 280ft.

Knowledge gained on that occasion is now being put to use and a pressure casing for containing the camera is

being designed and produced. These casings will have viewing windows through which the lens of the cameras will "shoot" the underwater scenes. A new type of gland has been devised for the camera cable. The cable is of special construction and is capable of being operated at depths of over 1,000ft.

The Marconi cameras have been used at varying depths and it has been found that in certain conditions good pictures are obtained as deep as 80ft without the aid of artificial light.

Tests made under practical conditions at sea show that artificial illumination of the object is of doubtful value when the water is clear, but many more results will have to be compiled and obtained before firm conclusions can be justified. Another interesting point shown by these sea tests is that tungsten lighting appears to give better results than either sodium or mercury vapour light.

Under test conditions some applications have already been thoroughly tried out—study of wrecks, finding of objects, and the investigation of the sea bed—and others which present themselves are the study of fish in their natural surroundings, the investigation of trawl nets under operational conditions, identification and control of oyster and scallop beds, inspection of dock gates and ships below the water line without employing divers or using dry docks, and the possibility of undertaking really deep-sea research to depths exceeding 1,000ft.

Referring to Chart 12, this corresponds to a k of 5×10^{-10} . Points on this response curve are: 0.1db at 2.75kc/s; 1db at 5kc/s; 2db at 6.1kc/s; 7db at 10kc/s; 20db at 22kc/s.

CHART 13

As with the phase Chart for the single reactance element networks, this one takes its reference from the 3db point of the amplitude characteristic. In this case the 3db point corresponds with 90° phase shift. To illustrate its use check points are listed for the examples taken above for amplitude characteristics.

Example 8

3db, 90° reference frequency for this low frequency cut-off network was 36.8c/s. Interpolating from Chart 13 for other points: 157° at 10c/s, 132° at 20c/s, 105° at 30c/s, 68° at 50c/s, 31° at 100c/s.

Example 11

When Charts 1-4, 5 and 6, or 12 are used to predict the amplitude response of coupled tuned circuits, the term phase characteristic is somewhat ambiguous. There are two frequencies at any point on the characteristic, either of which could be used as phase reference. From the viewpoint of steady state response, the phase is referred to the absolute frequency, although the frequency base used for plotting amplitude and phase response will be the difference from carrier frequency (modulation frequency, if the absolute frequency is taken as a side-band of the central carrier frequency). Sidebands below the carrier frequency will experience phase advance, while those above will be correspondingly delayed.

To refer the phase to the modulation frequency, the composite signal must be considered. To visualize this consideration better, it will be simpler to imagine a simple

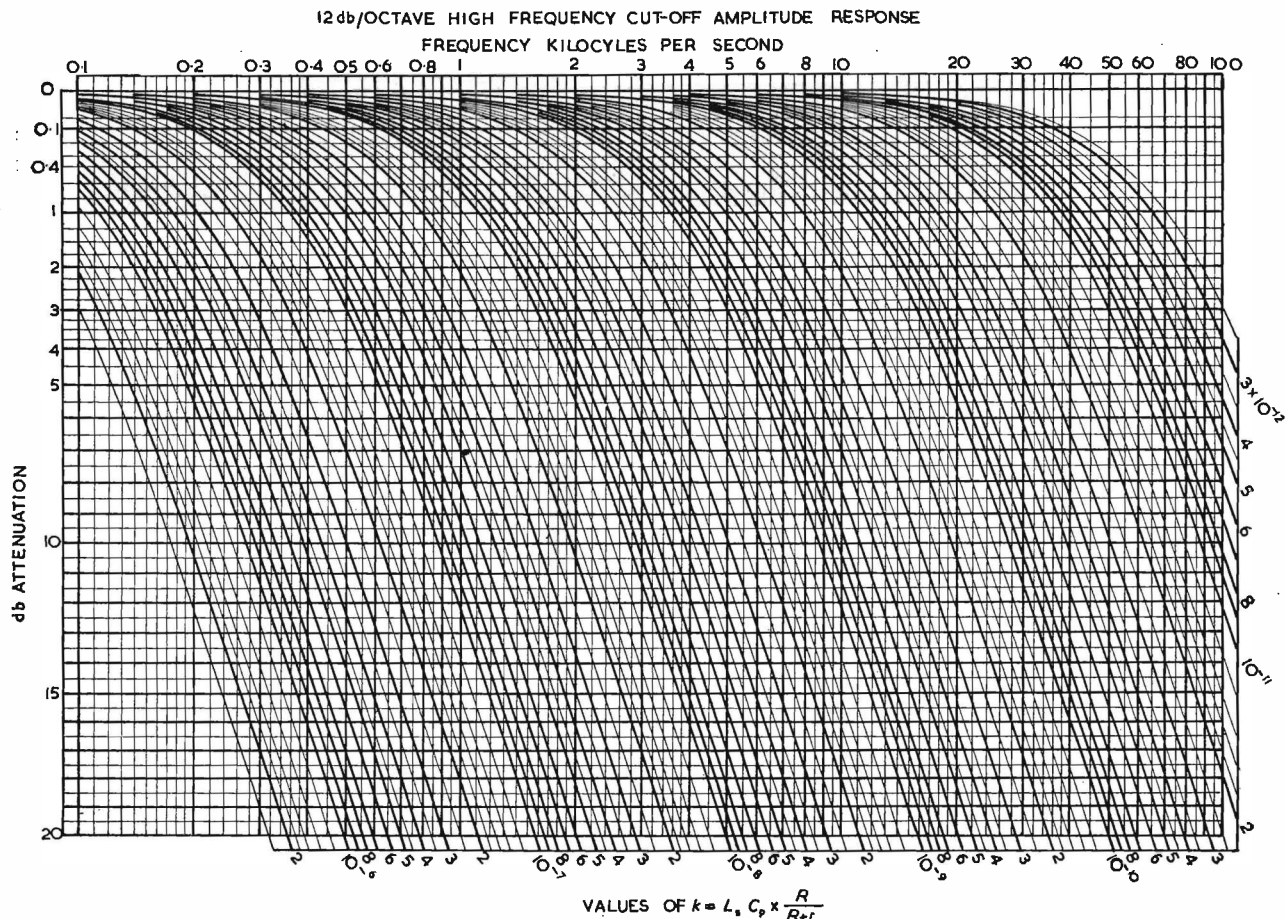

Chart 12. 12db/octave high frequency cut-off

Example 9

When Charts 11 and 12 are used to extend the range of Chart 6 for amplitude (or the amplitude charts in the first data sheet for 6db/octave), Charts 7 and 8 will cover the corresponding range in phase adequately. This has been provided because the inaccuracy introduced by using a 6 or 12db/octave approximation will be greater in phase than for amplitude.

Example 10

3db, 90° reference frequency for this high frequency cut-off network was 8.4kc/s. Interpolating Chart 13 for other points: 32.5° at 3.3kc/s; 65° at 6kc/s; 80° at 7.4kc/s; 102° at 10kc/s; 144° at 20kc/s; 153° at 26.3kc/s.

cyclic variation in amplitude of the carrier frequency, rather than a summation of three separate frequencies of constant amplitude. Due to the Q of the circuits, there will be a delay in the build up and decay of the oscillations induced, which, expressed as a phase angle relative to the cyclic variation (modulation) frequency, will rise with frequency. In general this phase delay will be identical with that for the simple audio coupling circuit to which it is analogous from the viewpoint of the amplitude response.

In Example 11, the 3db point is 7.07kc/s, from which the following points can be interpolated, using this as the 90° frequency on Chart 13: 32.5° at 2.75kc/s; 65° at 5kc/s; 80° at 6.1kc/s; 115° at 10kc/s; 153° at 22kc/s.

12 db/OCTAVE LOW FREQUENCY CUT-OFF AMPLITUDE RESPONSE

FREQUENCY CYCLES PER SECOND

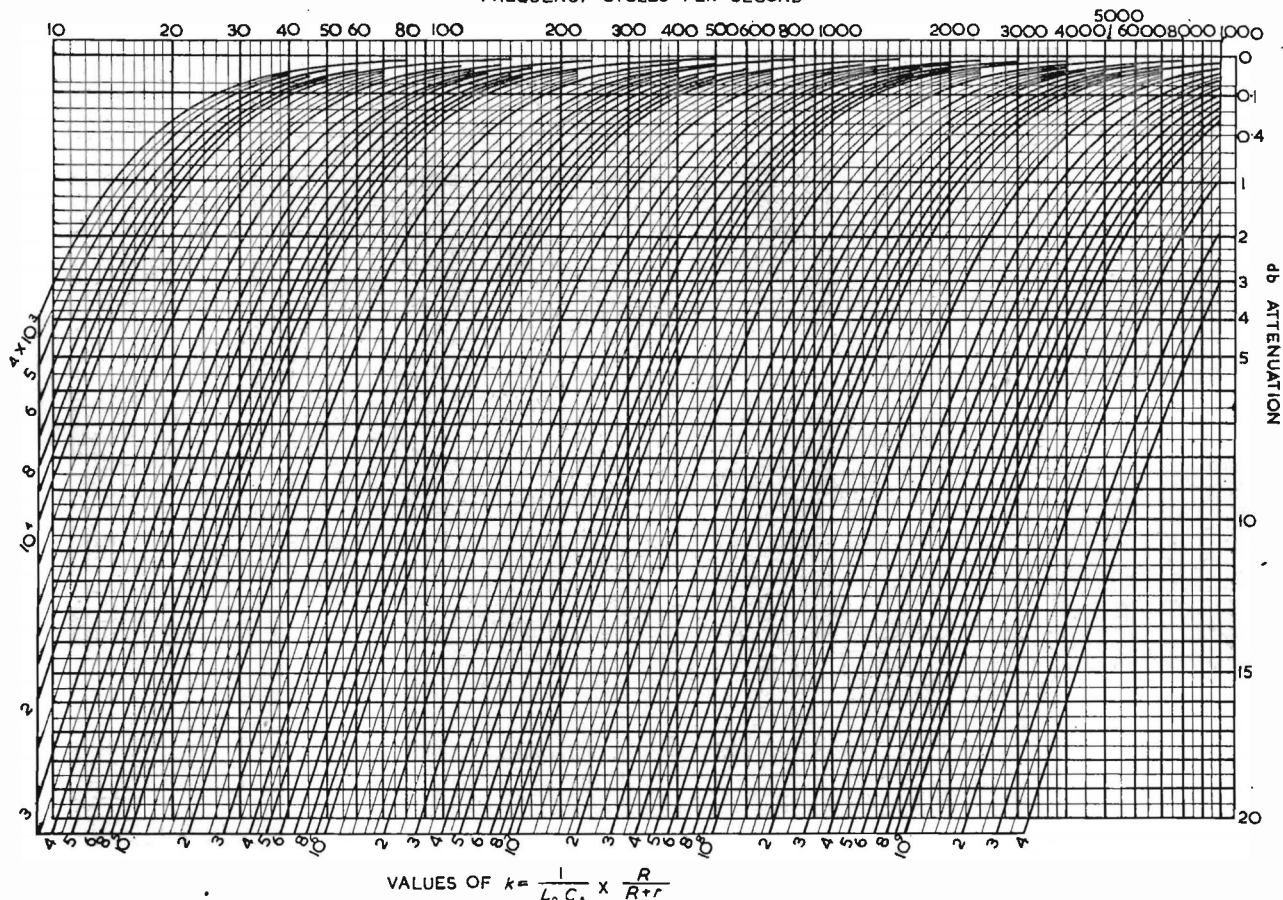

Chart 11. 12db/octave low frequency cut-off

The simplest method of applying Chart 12 is by use of the formula giving the 3db point. This is

$$f_3 = f_c / \sqrt{2} \cdot Q \dots \dots \dots (25)$$

CHART 11

Example 8

In Example 1, the effective primary source resistance is to be increased to produce a simple 12db/octave cut-off.

In Example 1, $L_p/2R^2C_s = 0.012$, so $r^2C_s/2L_p$ must be increased to 0.988 for the 12db/octave cut-off condition. Thus

$$r^2 = \frac{2 \times 300 \times 0.988}{5 \times 10^{-8}} = 1.185 \times 10^{10}, \text{ or}$$

$$r = 1.09 \times 10^5 \text{ ohms.}$$

A close approximation will be given by 100kΩ. Using this value to calculate k for Chart 11,

$$k = \frac{1}{300 \times 5 \times 10^{-8}} \times 1/1.2 = 5.5 \times 10^4 \text{ approx.}$$

Applying this to Chart 11, the 3db point is at 36.8c/s. Other points are: 20db at 12c/s; 11db at 20c/s; 4db at 33.5c/s; 2db at 42c/s; 1db at 52c/s; 0.1db at 96c/s.

Example 9

A network gives, according to Charts 5 and 9, a transition response, 0.1db down at f_i , 300c/s. According to Chart 6, the loss at one-fifth of 300c/s, i.e., 60c/s, is about 8db.

To extend the response further by using Chart 11, 8db at 60c/s corresponds to a k of about 3.3×10^5 . This value

can be used to compute the amplitude response below 60c/s, e.g., 14.5db at 40c/s.

CHART 12.

Example 10

In Example 2, the effective gain can be increased by raising the primary source impedance. To increase this so that the high frequency cut-off is 12db/octave, as $L_s/2R^2C_p = 0.0225$, $r^2C_p/2L_s$ can be raised to 0.9775, so

$$\text{that } r^2 = \frac{2 \times 4.5 \times 0.9775}{10^{-10}} = 8.8 \times 10^{10}, \text{ whence } r =$$

2.97×10^5 . This is referred to the secondary (see example 2, Part 1) so the actual value will be one-ninth of this, or 33kΩ. Calculating k for Chart 12,

$$k = L_s C_p \times \frac{R}{R+r} = 4.5 \times 10^{-10} \times \frac{1}{1.297} = 3.5 \times 10^{-10} \text{ approx.}$$

Applying this to the Chart, the 3db point is at 8.4kc/s. Other points can be interpolated, such as: 0.1db at 3.3kc/s; 1db at 6kc/s; 2db at 7.4kc/s; 4.75db at 10kc/s; 15.2db at 20kc/s; 20db at 26.3kc/s.

Example 11

Two tuned circuits, operating at a carrier frequency of 1Mc/s, have Q values of 50 and 200 (with their associated circuits). To find the critical coupling,

$$Q = 100, n = 2, m = 2\frac{1}{2}$$

therefore critical coupling will be such that

$$Q^2 k^2 = 2\frac{1}{2}, \text{ or } k^2 = 2\frac{1}{2}/10^4, \text{ and } k = 0.0146.$$

From Equation (25), $f_3 = 10^6/141 \text{ c/s} = 7.07\text{kc/s.}$

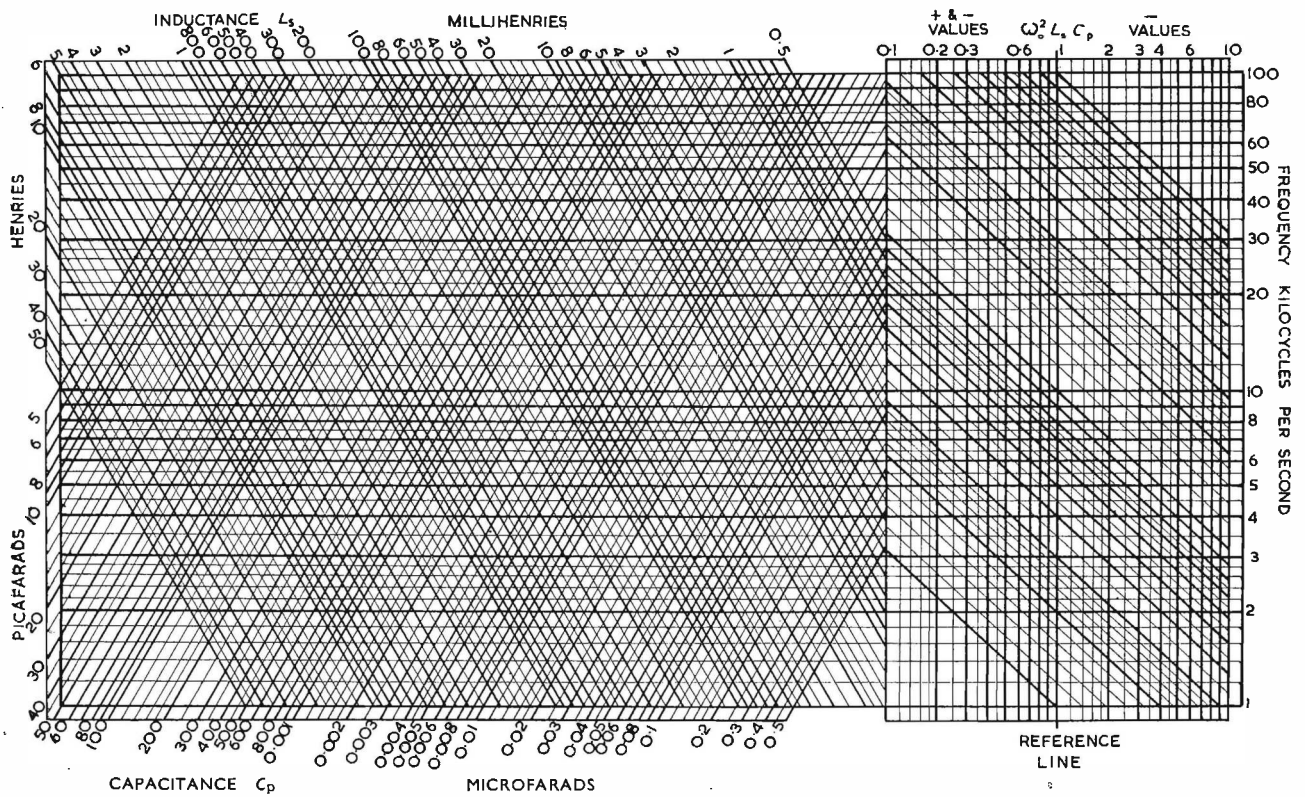

Chart 10. High frequency cut-off networks

Example 5

$$L_p = 130\text{H}, C_s = 0.02\mu\text{F}, \frac{1}{\omega_0^2 L_p C_s} = -5.1 \text{ (since } \frac{1}{\omega_1^2 L_p C_s} = 5.1).$$

Using the Chart, f_1 is about 45c/s. This is the reference frequency for Chart 6. As given from Chart 5, the reference for Chart 7 is 0.925 times this value, or about 41.5c/s.

CHART 10

Example 2

$$L_s = 4.5\text{H}; C_p = 100\text{pF}; \omega_0^2 L_s C_p = 0.955.$$

Using Chart 10, f_0 is about 7.3kc/s, or 7,300c/s. This is the reference frequency for Chart 2. As given from Chart 1, the reference for Chart 7 is 1.046 times this value, or about 7,600c/s.

Example 3

$$L_s = 60\text{mH}; C_p = 1,000\text{pF}; \omega_0^2 L_s C_p = 0.164.$$

Using Chart 10, f_0 is about 8.5kc/s, or 8,500c/s. This is the reference frequency for Chart 2. As given from Chart 1, the reference for Chart 7 is 2.6 times this value, or about 22kc/s.

Example 6

$$L_s = 77.5\text{mH}, C_p = 2,500\text{pF}, \omega_0^2 L_s C_p = -0.613 \text{ (since } \omega_1^2 L_s C_p = 0.613).$$

Using the chart, f_1 is about 9kc/s. This is the reference frequency for Chart 6. As given from Chart 5, the reference for Chart 7 is 1.33 times this value, or about 12kc/s.

12db per Octave Cut-off Case

Charts 11-13 have been designed to give direct reference curves for networks producing the 12db/octave cut-off case, similar to those given in the first data sheet of this series for circuits with a single reactance element producing

a 6db/octave cut-off. Charts 11 and 12 give the amplitude response for low frequency and high frequency cut-off networks respectively, while Chart 13 gives the phase response.

The condition for the 12db/octave case is that E of Equation (4) or (6) is zero. That is, for low frequency cut-off networks,

$$\frac{r^2 C_s}{2L_p} + \frac{L_p}{2R^2 C_s} = 1 \dots\dots\dots (21)$$

or for high frequency cut-off networks,

$$\frac{r^2 C_p}{2L_s} + \frac{L_s}{2R^2 C_p} = 1 \dots\dots\dots (22)$$

The amplitude response given by Chart 6 only caters for frequency within a range from one-fifth to five times the reference frequency, f_1 . If information concerning the amplitude response beyond this range in one or other direction is required, that in the region beyond the left-hand edge can be obtained by matching the loss at this edge frequency with a corresponding response curve on the amplitude charts given in the first data sheet of this series, while that for the region beyond the right-hand edge of Chart 6 can be obtained by similar matching with Chart 11 or 12. Example 9 illustrates an application using Chart 11 in this manner.

Chart 12 can also be used, as stated in relation to Charts 1-4 and 5 and 6, for the prediction of amplitude response, in the case of coupled tuned circuits where the coupling is "critical". The general condition for this, using the nomenclature introduced in Part 1 of this data sheet, is

$$k^2 Q^2 = m = \frac{1}{2}(n^2 + 1/n^2) \dots\dots\dots (23)$$

In the special case, where Q_1 and Q_2 are identical, this reduces to

$$k^2 Q^2 = 1 \text{ or } kQ = 1 \dots\dots\dots (24)$$

which is the better known expression for critical coupling.

Data Sheets for the Prediction of Audio-Frequency Response

No. 2—Circuits with Two Reactance Elements (Part 3)

By N. H. Crowhurst, A.M.I.E.E.

Determination of Reference Frequencies for Charts 2 and 6

Charts 9 and 10 are precisely similar in configuration and their use is illustrated at Fig. 6. They are designed to apply Equations (5) and (3) respectively, in the forms that occur for peaking or transition cases, to give the reference frequency for the responses predicted by Charts 2-4 or 5 and 6. The relation between this reference frequency and that used for Chart 7 is given by the additional scale on Chart 1 for peaking cases, or on Chart 5 for transition cases.

To illustrate use of these charts the same examples used in Parts 1 and 2 of this data sheet will be taken.

CHART 9

Example 1

$$L_p = 300\text{H}; C_s = 0.05\mu\text{F}; \frac{1}{\omega_0^2 L_p C_s} = 0.913.$$

Using Chart 9, f_0 is about 43c/s. This is the reference frequency for Chart 2. As given from Chart 1 (see Part 1),

the reference for Chart 7 is 0.93 times this value, or about 40c/s (by slide-rule).

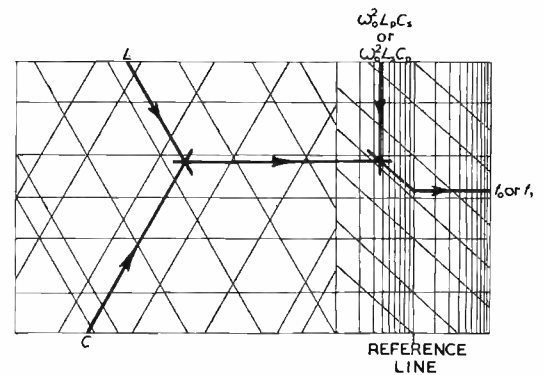
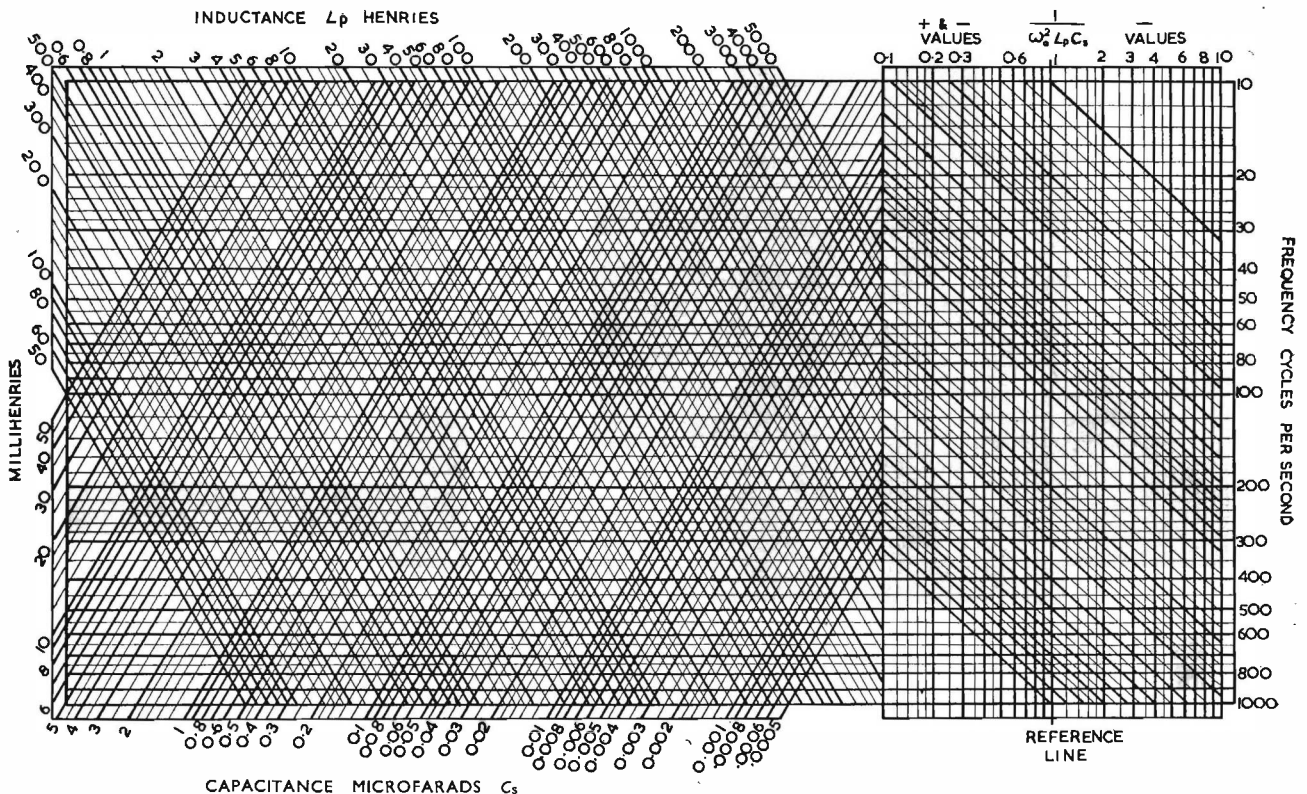

Fig. 6. Illustrating use of Charts 9 and 10

Chart 9. Low frequency cut-off networks



these difficulties, are inaccurate, and, unless special care is exercised, give only a rough indication of the vacuum.

The instrument developed at the Bureau consists of a pressure cell and an electronic micrometer, enclosed in a glass dome which can be evacuated or filed to any desired reference pressure. The pressure cell, the heart of the instrument, is composed of a very thin corrugated diaphragm sealed at the periphery to a slightly dished brass disk. This cell is connected to the gas sample so that change in pressure of the gas causes movement of the flexible diaphragm. Movement of the diaphragm in response to pressure variations is measured by a mutual-inductance micrometer placed over, but not in contact with, the diaphragm. Mechanical coupling errors are thus eliminated.

The micrometer was previously developed at the Bureau in connexion with the design of indicating devices to measure clearances in journal bearings. In principle, it makes use of the variation in mutual inductance between two concentric-air-core coils which results when the distance of the coils from a non-magnetic metal surface changes. When the metal is brought immediately adjacent to the end of the form supporting the coils, the mutual inductance is reduced to a minimum by what is effectively a "shielding" action of the metal. As the metal is moved away from the coils, the mutual inductance increases as a linear function of the separation.

In the micromanometer, the metal "shield" is the diaphragm of the pressure cell itself. Radio-frequency current is fed into a primary coil and induces a voltage in a secondary coil, mounted just above the diaphragm. The form supporting the coils is mounted rigidly with respect to the fixed portion (the brass disk) of the cell. Mutual inductance between coils is therefore a function of diaphragm expansion and hence is indicative of gas pressure.

This mutual inductance is compared to an adjustable reference value which is set in calibration for equality with zero differential in the cell. When pressure is applied, the balance is disturbed, and the resulting signal is proportional to gas pressure. This signal is amplified by suitable circuitry, is rectified, and finally appears as a direct current through the microammeter on the panel of the instrument.

Alignment of coil form and diaphragm is not critical

The pressure cell.

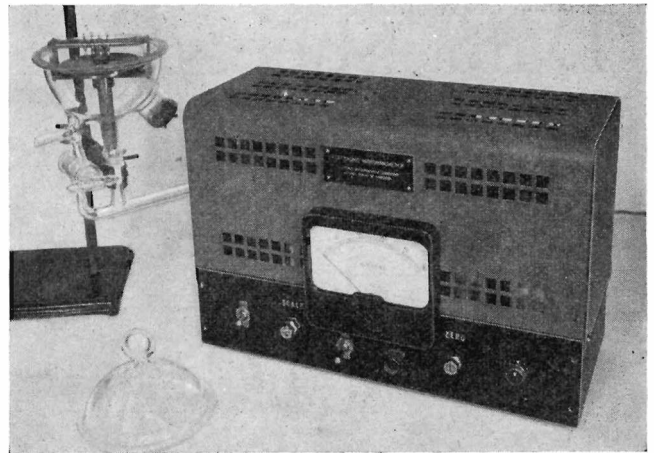
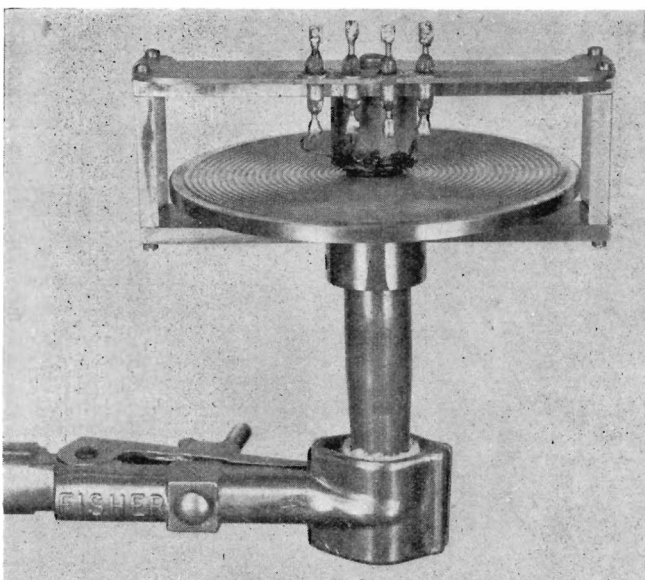

The diaphragm type micromanometer.

since, as a result of the linear response, all parts of the useful area of the diaphragm are weighted uniformly.

Because of the linear relationship between pressure variation and electrical output, only two calibration points are required. In practice, the cell is first evacuated to the same pressure as that prevailing in the glass dome. Thus no differential pressure on the diaphragm exists, and the reference mutual inductance may be adjusted for zero reading on the meter scale. Slope, or scale-factor, adjustment is then made upon the introduction of an expanded gas sample of known pressure.

The manometer is capable of measuring pressures in the range of 1 to 100 microns with a sensitivity of about 0.1 micron on a 50 micron scale. Continuous use of the instrument for more than one year on one of the mass spectrometers at the U.S.A. National Bureau of Standards has shown that its sensitivity and zero point are remarkably constant. Frequent observations have disclosed variations in calibration of less than 1 micron over a 24-hour period. A differential pressure of one atmosphere applied externally on the pressure cell has only a slight hysteresis effect while pressures up to several tenths of a millimeter can be applied inside the pressure cell without harmful effects on the diaphragm.

A Further Note on the Marconi Jubilee

A correspondent has pointed out that the information on which the statement in last month's commentary was based, namely, that "a regular trans-Atlantic wireless telegraph service was inaugurated from Poldhu in 1902" was incorrect. It appears that while the first *signals* (the letter 's') were transmitted from Poldhu in December, 1901, it was not until December, 1902 that the first *messages* were sent across the Atlantic—from Glace Bay to Poldhu. A limited public service was opened in October, 1907 between Glace Bay and Clifden (*not* Poldhu) followed by an unlimited service in February, 1908, which was interrupted when the Glace Bay transmitter was destroyed by fire in the autumn of 1909.

Our correspondent says that a new and more powerful plant was installed at Glace Bay and the service ceased only when the Clifden transmitter was put out of action during the Irish Rebellion. By this time—1914—the Carnarvon station had been built and from then onwards the trans-Atlantic traffic was handled by Carnarvon until the beam service replaced the longwave communication.

Calculation of the relationship between x and time

Let X be the voltage applied to the multiplier. Then $X = kt$ and $dX = k dt$. Also, let:

Multiplier Output Volts = $1/V_m \times$ Product of Input Voltages

and Integrator Output Volts = $1/T_A \times \int$ (Input Volts) dt

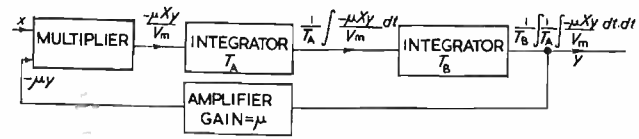

Fig. 11

In the above diagram (Fig. 11) it will be seen that

$$y = 1/T_A \cdot 1/T_B \int \int \frac{-\mu Xy}{V_m} dt dt$$

$$y = \frac{-\mu}{T_A T_B V_m} \int \int Xy \cdot 1/k^2 dX dX$$

differentiating twice with respect to X ,

$$d^2y/dX^2 + \left(\frac{\mu}{V_m T_A T_B k^2} \right) Xy = 0$$

Let $X = \alpha x$, then $d/dX = 1/\alpha d/dx$ and $d^2/dX^2 = 1/\alpha^2 d^2/dx^2$

$$\text{Thus, } d^2y/dx^2 + \left(\frac{\mu}{V_m T_A T_B k^2} \right) \alpha^3 xy = 0$$

$$\therefore \alpha^3 \left(\frac{\mu}{V_m T_A T_B k^2} \right) = 1$$

$$\alpha = \left(\frac{V_m T_A T_B k^2}{\mu} \right)^{1/3}$$

$$X = \alpha x = kt \quad \therefore x = k/\alpha t$$

$$x = \left(\frac{k\mu}{V_m T_A T_B} \right)^{1/3} t$$

A Diaphragm-Type Micromanometer

By Michael Lorant

This new type of instrument permits measurements that are totally independent of the type of gas or vapour being measured.

A DIAPHRAGM-TYPE micromanometer, utilizing an electronic pick-up, has been developed recently at the U.S.A. National Bureau of Standards to measure differential pressures in the micron region. Constructed for use with a mass spectrometer, the micromanometer gives rapid, direct readings of pressure on a microammeter scale that can be calibrated directly in units of pressure. It is relatively insensitive to temperature changes, will operate

into the reservoirs of the machine, where it expands to 1,000 times its original volume. Its pressure is then assumed to be one one-thousandth of its original pressure, but this assumption fails to account for losses that occur through absorption of the vapour by stop-cock grease and the walls of the system, and deviation from perfect gas laws.

It is desirable, therefore, to measure the pressure of the sample in the reservoirs after the losses have occurred. Manometers for the range from one thousandth of a millimeter to one tenth of a millimeter of mercury are usually

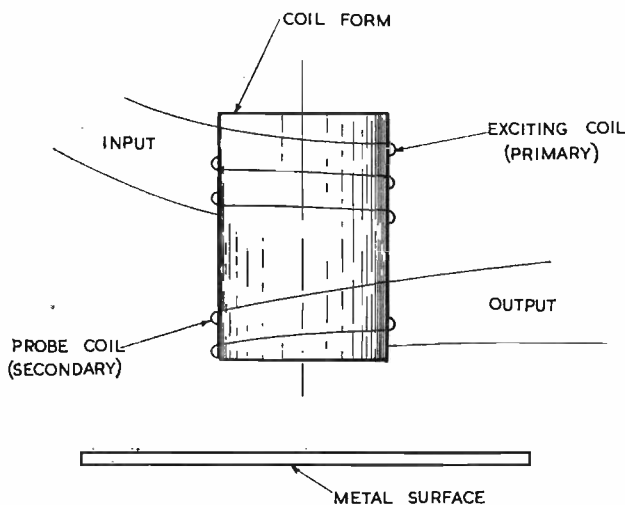

The principle of the electronic pick-up.

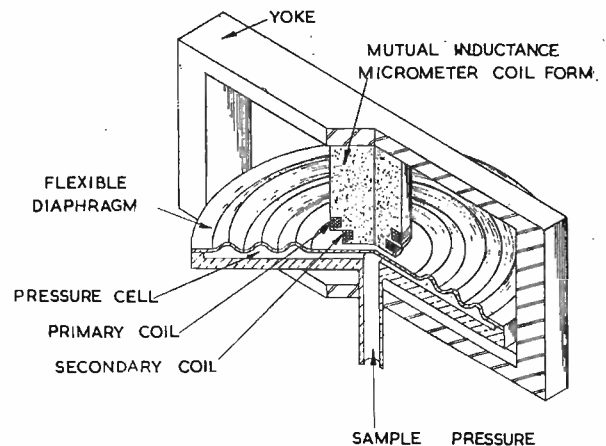

Cross-sectional view of the pressure cell.

in any position, and permits measurements that are totally independent of the type of gas or vapour being measured.

The need for such an instrument arises from the inevitability of error in the usual method of measuring gases for use in a mass spectrometer. A small sample is measured in an ordinary U-tube manometer and passed

liquid-level devices, such as McLeod gauges, or depend on thermal effects, such as Pirani or thermocouple gauges. McLeod gauges are accurate, but the presence of mercury or oil vapour introduces difficulties into vacuum work; besides, these instruments are bulky and inconvenient to use. Pirani and thermocouple gauges, while avoiding

cant sidebands of the frequency modulated carrier, and the response is made flat-topped, so as to make the open-loop gain vary as little as possible with frequency. Using for V_1 a valve with a high suppressor slope, such as a VR116, an open-loop gain of about -10 can be obtained, reducing the effect of any non-linearities, etc., by a factor of 11.

Frequency modulation is done by a variable reactance valve connected across the oscillator tuned circuit (Fig. 5). So as to ensure that frequency modulation is not accompanied by amplitude modulation, the reactance valve must present no damping to the oscillator tuned circuit.

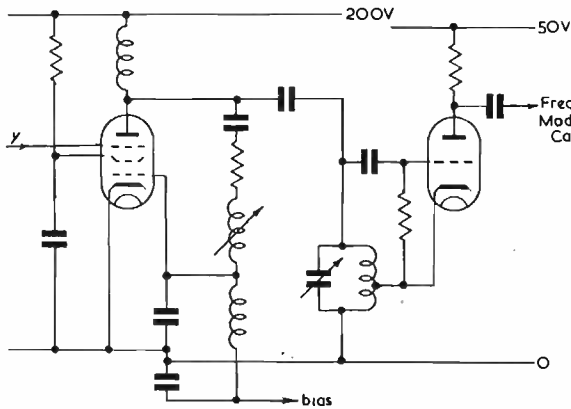

Fig. 5. The frequency modulator

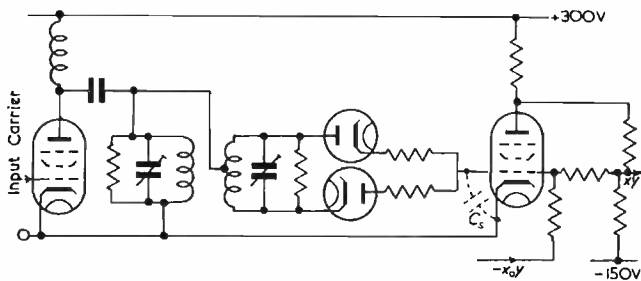

Fig. 6. Arrangement for negligible time lag



Fig. 7. The arrangement required to solve Airy's equation



Fig. 8. The triggering waveform

Fig. 4 shows two alternative arrangements to ensure that the grid volts are in perfect quadrature with the anode volts, and that i_a is therefore in perfect quadrature with e_a . Correct compensation is obtained by adjustment of L . A slight modification of the usual design of phase discriminator has to be used, to ensure a maximum speed of response. The arrangement shown in Fig. 6 gives negligible time lag due to smoothing, and the amount x_0y may be conveniently subtracted, as shown.

An Analogue Computer for Solving Airy's Equation,

$$d^2y/dx^2 + xy = 0$$

The diagram of Fig. 7 shows the arrangement required,

to solve the equation. Integration is done by Miller integrators, which will integrate with respect to time. x must therefore be replaced by time, so that the equation being solved is $d^2y/dt^2 + Kty = 0$. Thus the actuating waveform, x , must be a voltage varying linearly with time. This x sweep is made to commence at $x = 0$, and to have a repetition rate of something like 20 per second—fast enough to eliminate flicker on the C.R.T. screen upon which the solution is displayed.

At the commencement of each sweep, (i.e., at $t = 0$), initial conditions on dy/dt and y have to be inserted. dy/dt and y are represented by the potentials across the integrating capacities; so, after the linear sweep of x , these capacities are charged, or discharged to fixed voltages

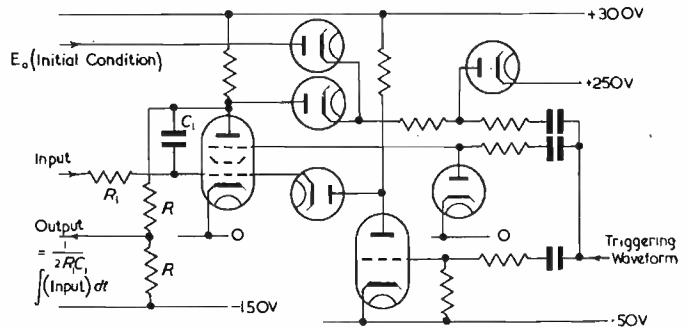

Fig. 9. The integrating circuit

(In a subsequent circuit a resistor is connected across the suppressor grid diode)

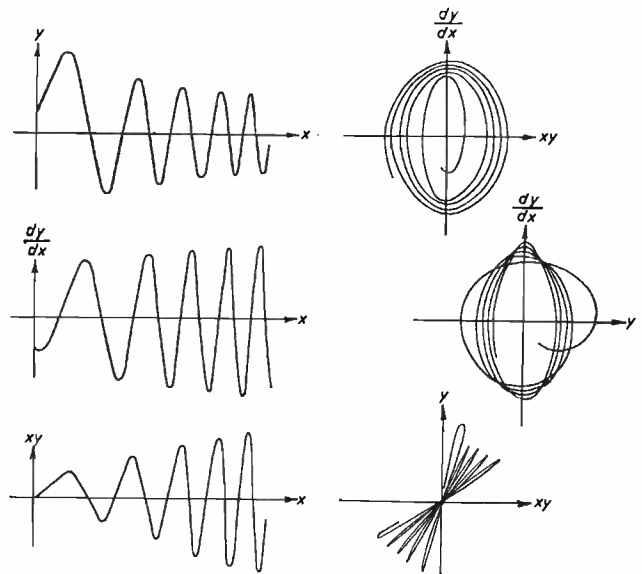

Fig. 10. Traces of Airy's integral

which determine $dy/dt|_{t=0}$ and $y|_{t=0}$. This is done before the following sweep commences, and at $t = 0$ these initial conditions are released. A triggering waveform, used for the insertion and release of the initial conditions, is generated with the x waveform, as shown in Fig. 8.

Fig. 9 shows the integrating circuit, in which the voltage E_0 determines the initial condition on the output voltage.

There are two independent solutions to Airy's Equation, $d^2y/dx^2 + xy = 0$. These solutions are represented by $A_1(x)$ and $B_1(x)$. The general solution is therefore $y = \alpha A_1(x) + \beta B_1(x)$.

For $x < 0$, $A_1(x)$ tends to zero, and $B_1(x)$ to infinity. The solution for $x > 0$ is more interesting, and it is for this part of the solution that traces were taken (See Fig. 10).

By correct insertion of initial conditions on dy/dx and y , either $A_1(x)$ or $B_1(x)$ may be separated out.

An Electronic Multiplier

By M. J. Somerville, B.Sc.

THE multiplier described here was designed for use in an analogue computer, for which purpose no time lag in multiplying could be tolerated. The aim has been, therefore, to make any time lag negligible, rather than to obtain very high accuracy.

Multiplication is achieved as follows:

A radio frequency carrier is frequency modulated about a fixed frequency f_0 , to have a frequency deviation proportional to one of the multiplicands, y . This frequency modulated carrier is then amplitude modulated, proportional to the other multiplicand, x . The resulting carrier is now taken to a phase discriminator, from which the output will be proportional to the product xy . (See Fig. 1).

Variation in y causes a change in sign of the output, corresponding to a change in sign of y , but x does not change the sign of the output. However, by adding to x a fixed voltage x_0 (where $x_0 > x_{min}$), and multiplying y by $(x_0 + x)$, the multiplier output is $xy + x_0y$. The

amplitude would be reproduced in the output carrier, which would also have variations in amplitude caused by change in carrier frequency, since the tuned circuit frequency response cannot be perfectly flat. The amount by which these variations are reduced is determined by the open-loop gain of the negative feedback loop.

The equivalent circuit is as shown in Fig. 3, where A is the gain from V_1 suppressor to D_1 anode.

$$\text{Open-loop gain} = G = A \cdot \frac{R_1}{(R_1 + R_2)}$$

$$\therefore 1/A = 1/G \cdot \frac{R_1}{(R_1 + R_2)}$$

$$\text{Now, } e_1 = x \frac{R_0}{(R_1 + R_2)} + e_0 \frac{R_1}{(R_1 + R_2)} = e_0/A$$

$$\therefore R_1/R_2 \cdot e_0 = \frac{G}{(1 - G)} \cdot x \quad \dots \dots \dots (1)$$

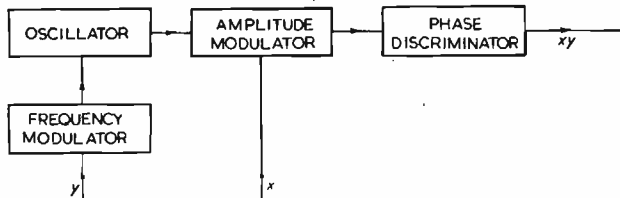

Fig. 1. The multiplier

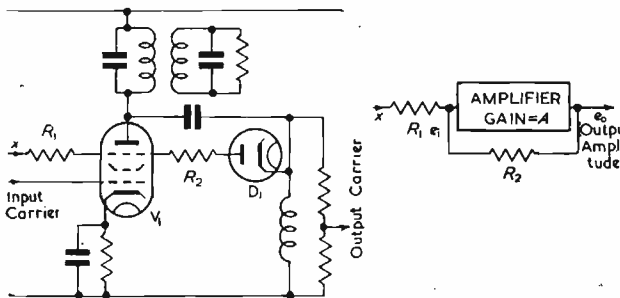

Fig. 2. Circuit for amplitude modulation Fig. 3. Equivalent circuit

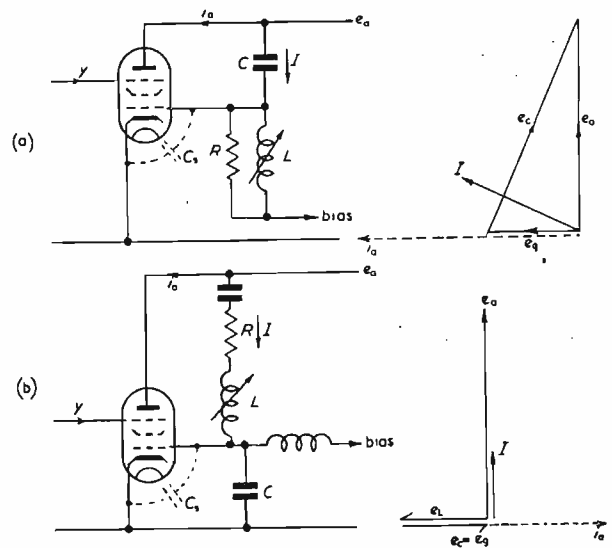

Fig. 4. Alternative arrangements to ensure that grid voltage is in quadrature with anode voltage

required product, xy , is then obtained by subtracting x_0y . x can then have either positive or negative values, giving a corresponding change in sign of the product.

Fig. 2 shows the circuit used for amplitude modulating the frequency modulated carrier. V_1 suppressor is used to amplitude modulate, the frequency modulated carrier being applied to V_1 control grid. The amplitude and frequency modulated signal appearing at V_1 anode is rectified by D_1 , and a voltage proportional to the output carrier amplitude is thus applied, via R_2 , to V_1 suppressor. x is also applied to V_1 suppressor, via R_1 , so that the suppressor voltage will be proportional to the error in output amplitude. Any error is therefore decreased by means of this negative feedback. The open-loop gain of the negative feedback loop depends mainly upon the amplitude of the frequency modulated input, but also upon frequency, and upon the suppressor voltage.

Without negative feedback, any variations in input

Any error, whether it be due to change in frequency, input carrier amplitude, or change in suppressor slope with suppressor voltage, may be considered as giving a change in A , of dA . So that, in the absence of feedback, the error in output amplitude would be $dA/A (=dG/G)$.

Differentiating Equation (1)

$$R_1/R_2 \cdot de_0 = x \frac{(1 - G) dG + GdG}{(1 - G)^2}$$

$$R_1/R_2 \cdot de_0 = x \frac{G}{(1 - G)} dG/G \frac{1}{(1 - G)}$$

$$\text{i.e., } de_0/e_0 = dG/G \times \frac{1}{(1 - G)}$$

Thus, any variations are reduced by a factor $1 - G$

The anode tuned circuit is wide-tuned, ($f_0 = 5\text{Mc/s}$) to give a bandwidth wide enough to include all the signifi-

winding, but again there must be a radial slot to prevent it acting as a short-circuited turn and the assembly is such that this slot is 180° away from the bobbin slot so that the function of this screen is to shield the edge of the secondary winding part of which is exposed by the bobbin slot.

The identical primary windings are made by winding a twin flex of say 36 s.w.g., D.S.C. wire uniformly along the former and twisting all four wires together to lead them away to terminal tags. Symmetry in appearance is a good and sufficient guide in making this winding and the terminations. The twin-flex is made by taking a large narrow loop of wire, one end of which is secured round a nail and the other end passes through a wire hook held in the chuck of a wheel brace. Then with a light steady tension the loop is wound into a uniformly twisted flex. (The pitch of the twist should be small compared with the circumference of a single turn on the former so that there is no tendency for the wires to spread apart when being wound on the former.)

It is convenient, but not essential, to use an iron dust core for the former and such a transformer is shown in Fig. 2, in which the local screening flap over the secondary outer foil slot can be seen, as well as the simple fabricated construction developed by the author.

Care should be taken to keep all connexions in the measuring circuit as short as possible and to screen the source and detector leads right up to the compact measuring circuit. Before making a measurement of resistance,

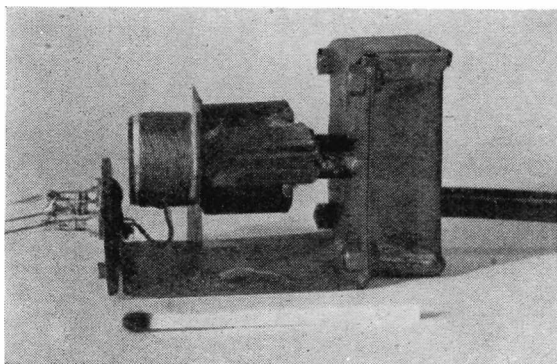

Fig. 2. Balanced measuring transformer

obvious checks should be made to confirm that the detector does not respond to any signal except that due to mutual inductive coupling between the primary and secondary.

The effective series capacitance or inductance of the crystal is measured by inserting a known capacitance in series with the crystal when it is controlling an oscillator as an effective series resonant circuit. The capacitance required is usually of the order of a few hundred picofarads, and this is wired in place but short-circuited initially. The frequency of the oscillator is measured or monitored and then the short-circuited wire is cut and the immediate change in frequency is noted by beat counting. (This technique of cutting the wire rather than disconnecting the capacitor has the advantage of speed so that the measurement is less affected by inherent frequency drift which is probably present.)

If we assume that the oscillator frequency corresponds to the series resonance of the control element, then neglecting stray capacitance, with the series capacitor short-circuited:

$$\omega^2 = 1/LC \dots\dots\dots (1)$$

where ω = Oscillator frequency in radians per second.

L = Effective series inductance of the crystal.

C = Effective series capacitance of the crystal.

Now with the capacitor C_s in series with the crystal so that the total series capacitance becomes C^1 , suppose the frequency changes to $(\omega + \delta\omega)$ then:

$$(\omega + \delta\omega)^2 = 1/LC^1 \dots\dots\dots (2)$$

dividing (2) by (1) and writing $C^1 = \frac{CC_s}{C + C_s}$

$$(1 + \delta\omega/\omega)^2 = (1 + C/C_s)$$

Now $\delta\omega/\omega \ll 1$, hence expand by the Binomial Theorem:

$$1 + 2\delta\omega/\omega \cong 1 + C/C_s$$

$$C \cong 2\delta\omega/\omega C_s \dots\dots\dots (3)$$

Thus

$$L \cong \omega/2\delta\omega \cdot \frac{1}{\omega^2 C_s} \dots\dots\dots (4)$$

and

$$Q \cong \frac{1}{2\delta\omega C_s R} \dots\dots\dots (5)$$

Where R is the effective series resistance of the crystal as measured with the balanced transformer.

In practice, the approximations are entirely justified as the order of frequency change used will be a few parts in one hundred-thousand, and the main source of error will be in neglecting stray capacitances and in the indefiniteness of the added series capacitance.

Acknowledgment

In conclusion the author wishes to express his thanks to the Chief Scientist of the Ministry of Supply for permission to publish this article.

REFERENCES

- ¹TERMAN, F. E. : Radio Engineers Handbook, Sec. 6, p. 495. (McGraw Hill).
- ²HARTSHORN, L. : Radio-Frequency Measurements, Ch. X, p. 183.
- ³HUND, A. : High Frequency Measurement, Ch.II, Sec. 34, p. 87.
- ⁴TERMAN, F. E. : Radio Engineers Handbook, Sec. 2, p. 45 Table 8. (McGraw Hill).

Robot Capacitor Grader

The capacitor grading equipment illustrated below was exhibited by the Telegraph Condenser Co. Ltd., at the recent exhibition of the Television Society.

The equipment is based on a Wien bridge which has one variable arm searching through the tolerances. By

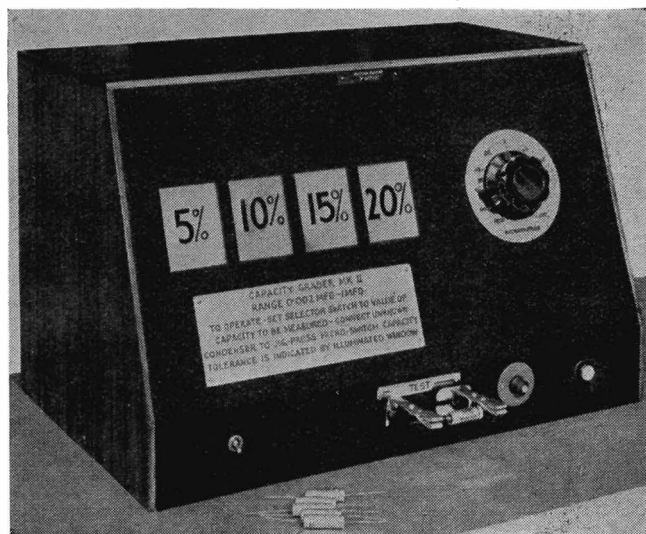

means of suitable amplifiers and switch gear the 5 per cent, 10 per cent, 15 per cent and 20 per cent tolerances are quickly measured in succession and when balance is obtained the appropriate indicator is illuminated.

Piezo-Electric Crystal Constants

By W. R. Hinton, A.M.I.E.E.

The construction of a balanced measuring transformer is described in detail together with the technique of its use to measure the effective series resistance of a crystal. A method of measuring the effective series reactance, and hence the "Q," by allowing the crystal to control the frequency of an oscillator is also given. (This last measurement can be done conveniently during the normal temperature coefficient checks, provided the oscillator excites the crystal into equivalent series resonance.)

THE equivalent circuit of a piezo-electric crystal is frequently required in development work. For example, when making lamp bridge oscillators¹ for frequency standards it is necessary to know the effective series resistance of the crystal in order to design the amplitude limiting circuits correctly, and some means of comparing Q is useful for selecting crystals. The determination of the equivalent impedances by conventional resonant circuit methods² can be very tedious and difficult owing to the very high Q involved and the consequent extreme sensitivity of the measurement to the frequency of test. The author has found that a balanced transformer technique for the resistance measurement is rapid and easy to carry out, and the Q can then be determined from changes in frequency observed when the crystal is controlling an oscillator as an effective series circuit. (This can be done conveniently when the temperature coefficient of the crystal is being checked.)

The use of balanced transformers³ for R.F. measurements is well known but does not seem to be very widely adopted, perhaps due to the difficulty in obtaining variable reference standard impedors or because few people realize how easy it is to make accurately balanced measuring transformers. At frequencies of a few hundred kilocycles per second, good quality resistance boxes are quite adequate as reference standards,⁴ particularly in this application where the series resistance of the crystal is likely to be in the order of a few thousand ohms.

The measuring circuit is shown in Fig. 1, where it is seen that the current from the signal generator passes through each half of the primary in opposite directions so that when these currents are exactly equal, the ampere-turns of one half winding are cancelled by those of the other half and therefore there is no net magnetic flux in the core and a null indication is obtained in the detector. Since the signal generator E.M.F. is common to both the unknown and the reference standard impedors this null condition corresponds to equality of these impedances in magnitude and phase angle.

The technique of measurement is to rock the signal generator frequently gently to and fro through the resonant frequency of the crystal and adjust R until the response clearly passes through a null balance condition. This method avoids the need for a highly stable source although it is an advantage to have a fine frequency control on the signal generator.

The main advantage of a balanced transformer method is that it does measure the direct series impedance because stray capacitance from terminal A to earth falls across the source and does not affect the measurement. Stray capacitance from B falls across one half of the primary winding but this has a negligible effect because at balance

there is no flux in the core and therefore each half of the primary winding has zero inductance; thus the stray capacitance falls in quadrature across a fraction of an ohm comprising the pure resistance of the half winding. Obviously similar remarks apply to terminals C and D and since it is wise to throw the smaller stray capacitance across the half-winding it is customary to connect the screen of the resistance box to the live side of the generator as shown.

The details of the balanced transformer construction must vary depending on the materials available but it is essential that the following conditions are fulfilled. First the secondary must receive energy only from magnetic coupling with the primary, and this implies efficient electric screening of the secondary right up to and including the receiver. Secondly, in this application each half of the primary must be electrically identical with the other.

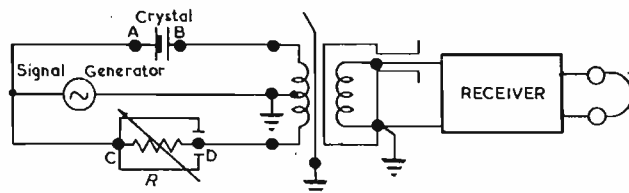

Fig. 1. Circuit for measuring resistance

The first condition can be met by constructing a bobbin of copper foil with thick wire soldered along the edges to form the cheeks and this is best done after shaping. A longitudinal saw cut is then made down the bobbin to prevent it acting as a short-circuited turn. Thin paper is used to insulate the bobbin which is then wound with wire consistent with the self-capacitance permissible with the frequency range used. The choice of wire and the number of turns is not critical as any loss in sensitivity due to departing from an optimum design can be compensated by increasing the receiver gain, and the construction of the transformer is more a mechanical problem than an electrical one. The completed winding is then insulated with a layer of paper, more as a mechanical protection from the next operation of soldering an outer copper foil around the bobbin leaving a fine slot again to prevent it acting as a short-circuited turn. The wires can be brought out of this slot and locally shielded up to a metal terminal box. This local shield should also be extended to keep the slot in the "shadow" of any nearby electric fields, and should be soldered to one edge of the outer foil only.

In addition to the above, a simple shield is inserted on the former between the primary and the secondary

tion to those utilizing the thermo-electric effect. For work of the highest accuracy at high temperatures the platinum resistance thermometer and the precious metal thermocouples hold the field, although the several types of alloy thermo-couple which are commercially available and which give greater sensitivity (copper-constantin and chromel-alumel) are quite satisfactory at lower temperatures: the last mentioned may be used up to about 750°C. if periodically annealed and re-calibrated.

For higher temperatures, up to 2,000°C. and over, radiation or optical pyrometry is widely used (commonly employing non-electronic instruments), with the considerable advantage that the measurement can be made at a distance from the hot body. Total radiation pyrometers,

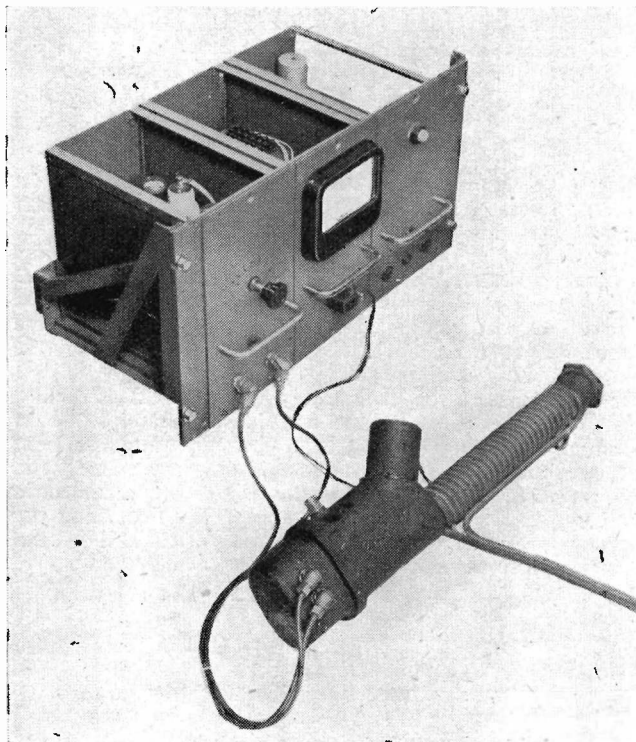

Fig. 16. A low temperature radiation pyrometer

in which radiation from the hot body is focused on to a group of fine wire thermocouples attached to a small receiver plate, are suitable for direct-reading indication of temperatures above 600°C., while optical pyrometers of the "disappearing filament" or colour comparator types can be employed with moderate accuracy above 800° or 900°C.

Recently the range of temperatures covered by radiation measurements has been considerably extended in the downward direction by the introduction of the lead-sulphide photocell¹⁴. Originally developed in Germany at the beginning of the war, and concurrently also in America, this cell has an extremely high sensitivity in the near infrared region of the spectrum (1–3 μ) and has made possible the measurement of surface temperatures by radiation down to 100°C. Its operation depends on change of conductivity of the active coating of lead sulphide with incident radiation. Various types are now commercially available in this country. In one of these two parallel strips of active coating are provided, each approximately 1mm wide, so arranged that by providing a suitable shutter to interrupt the radiation falling on each element in turn a differential a.c. output signal may be obtained, enabling zero drift due to changes of cell temperature to be eliminated. A pyrometer head designed to operate on this principle; and incorporating an 800c/s interrupter, is shown

in Fig. 16. Miniature cells of the same type have been applied in another instance, using D.C. amplification, to measure instantaneous flash temperatures on the surface of brake drums¹³.

In addition to the considerable number of actual devices of the types considered, there are a number of less concrete physical effects, which form the basis of electronic measuring systems. Two classes of these are indicated in the table as "variable induction" devices and "electro-chemical effects," some examples of these having already been described. In the former category, utilization of the variations in *BH* characteristics between different samples of ferrous materials in the magnetic sorting bridge was described in the first part of this article, and reference was also made to the eddy-current crack detector. This last device makes use of the skin effect at high frequency in metallic conductors coupled to an inductance coil. The same fundamental principles are utilized in various forms of metal detectors and also in the eddy current disk position indicator device.²

CHOICE OF TYPE OF DETECTOR

It will be apparent that in considering the equipment required for any new measurement problem which may arise, the first step will always be to select the form of detector device to employ; and this, furthermore, will often involve choosing from quite a number of possible types. The selection will depend on several factors, some associated with the nature of the quantity to be measured, others with the electronic circuit to be employed. From the former standpoint the necessary sensitivity, the required accuracy of measurement, rate of change of the measured quantity, the effect of the device on the system under test, accessibility of and conditions at the point of measurement, robustness and permissible cost of the equipment are all factors which must be considered. From the latter viewpoint the type of indication or display required (meter reading, C.R.T. display, ink-on-paper or photographic oscillograph record, numerical answer on a counter etc.); the need for static or only dynamic response; the suitability of direct or carrier-frequency amplification; the means to be adopted for standardization and calibration, are relevant considerations upon which the final choice will depend. The availability of suitable electronic "Amplifier" units will also, frequently have to be considered and in this connexion it is worth noting that various extremely versatile electronic systems have been developed which cater for a variety of different kinds of detector.

(To be continued)

REFERENCES

- ²² An Aerodynamic Balance for a High Speed Wind Tunnel. *Engineering*, p. 9, 175, 223, 272, Feb.-March (1949).
- ²⁴ T. G. THORNE: The Automatic Guiding of Astronomical Telescopes. *Engineering*, Feb. 24, p. 197, (1950).
- ²⁶ H. W. BABCOCK: A Photographic Guider for Astronomical Telescopes. *Astrophysical Journal CVII*, 1, 73.
- ²⁸ H. M. SMITH: The Determination of Time and Frequency. *Proc. I.E.E.* Vol. 98, Pt. II, No. 62, p. 143, April (1951).
- ²⁷ W. B. FLOYD: Electronic Machines for Business Use. *Electronics*, May, p. 67 (1950).
- ²⁸ KUCHRI and PETERSON: A New Differential Analyser. *Electrical Eng.*, May, p. 221, (1944).
- ²⁹ D. J. MYNALL: Electrical Analogue Computing. *Elec. Engg.*, XIX, 178 (1947).
- ³⁰ MCCANN and WILTS: Application of Electrical Analog Computers to Heat-transfer and Fluid-flow Problems. *J. Applied Mech.*, p. 247, Sept., 1949.
- ³¹ F. G. WILLEY: Electrical Solution of Thermal Problems. *Elec. Engg.*, p. 190, Aug. (1946).
- ³² Electronic Computers. *Elec. Engg.*, Aug. (1946).
- ³³ P. E. GREEN: Automatic Plotting of Electrostatic Fields. *Rev. Sci. Inst.*, 19, p. 646 (1948).
- ³⁴ MAXWELL, CLERK: A Treatise on Electricity and Magnetism. Vol. II, art. 647-51. (Oxford University Press, 1881.)
- ³⁶ BOOTHROYD, CHERRY and MAKAR: An Electrolytic Tank for the Measurement of Steady State Response and Allied Properties of Networks. *Proc. I.E.E.*, Pt. I 96, p. 163 (1949).
- ³⁷ LYON, G.: Some Experiences with a British A.C. Network Analyser. *Proc. I.E.E.*, 97, Pt. II, p. 697 (1950).
- ³⁷ C. L. BLACKBURN (British Patent No. 476,164): Improvements in or relating to Electrical Calculating Machines (1937).
- ³⁸ E. J. WOODCOCK: Some Electrical Methods of Measuring Mechanical Quantities. *Proc. I.E.E.*, 97, Pt. I, p. 136 (1950).
- ³⁹ A. DOUGLAS: An Electrical Displacement Meter. *Elec. Engg.*, XXII, 215 (1950).
- ⁴⁰ POSTLETHWAITE: Design of Vibration Pickups. *Engineering*, p. 363, Nov. (1943).
- ⁴¹ R. J. JEFFRIES: Velocity-Acceleration Response from a Seismic Pick-up via Controlled Damping. *Rev. Sci. Inst.* 21, p. 115 (1950).

operation on transformer action, the motion to be studied being applied, in each instance, to a part of the magnetic circuit. The a.c. moving-coil pick-up element, illustrated at (b) strictly falls into this class also, but has been grouped with the permanent magnet (D.C.) moving-coil in view of its obvious similarity to the latter.

An important feature of the a.c. moving-coil detector, and those of Fig. 14 (g and h)—all a.c. polarized—is its ability to give indication of static displacements. In common with bridge circuits, employing a.c. polarization, this group is characterized by having an output a.c. voltage signal which is zero at some "zero" displacement or balance position and increases linearly, or nearly so, with displacement from this point: reversal of phase occurs on

the simple procedure of counting, on a cathode-ray oscillograph, of the number of light and dark transitions passed through in one complete cycle of vibration, as the lines of one grating coincide alternately with the lines and the spaces of the other. Alternatively, for very small amplitudes of vibration, less than half the grating pitch (i.e., <0.005 in), the same arrangement gives extremely sensitive indication of displacement by utilizing the continuously varying degree of light transmission. Many other similar applications of photocells for indirect measurement, using the interruption or deflexion of a light ray as an inertialess detector device, will readily be called to mind.

Besides the great variety of specially made instruments

DETECTOR DEVICE	TYPE OF MEASUREMENT	Also used for :
Resistance strain gauge	DISPLACEMENT (static or dynamic)	STRAIN POSITION INDICATORS FORCE PRESSURE THICKNESS (insulating sheets or films—also plating on iron.)
Variable inductance		
Variable mutual inductance		
Variable capacitance		
Magnetostriction		
Eddy current disk	DISPLACEMENT (dynamic only)	THICKNESS (insulating sheets or films—also plating on iron.)
Moving coil (A.C. polarized)		
Piezo-electric crystals :	FLUID VIBRATIONS SOUND FREQUENCY AND WAVEFORM ANALYSIS	(Carbon type unsuitable for quantitative measurements)
Rochelle salt		
Quartz (also used for inverse effect)		
Moving coil (D.C. polarized)		
Microphones :		
Piezo-electric	FLAW DETECTION OR THICKNESS—IN METALS OF LARGE THICKNESS	Also used for :
Capacitance		
Moving coil		
Ribbon		
Carbon		
Piezo-crystal (supersonic method)	TEMPERATURE (including radiation method)	CHEMICAL ANALYSIS by Infra Red absorption
Resistance thermometer (Platinum)		
Thermistor		
Bolometer		
Thermocouple		
Thermopile	LIGHT MEASUREMENTS	Indication of mechanical displacements
Lead Sulphide Photocell		
Photo-cells :		
Vacuum (H.F. response)		
Gas-filled		
Selenium	pH MEASUREMENT (ACIDITY ELECTRO-CHEMICAL ANALYSES)	MAGNETIC SORTING BRIDGE APPLICATIONS (50 cycle waveform variations) CRACK DETECTION
Photo-conductive (high sensitivity)		
Electro-chemical effects		
"Variable Induction" (samples in solenoid)		

passing through the zero position. This characteristic has an important bearing, as we shall see later, on the design of the associated electronic measuring circuits.

Actual detector devices using the various elements illustrated are too numerous to catalogue and only a few typical examples can be mentioned. The most popular type of pick-up for experimental vibration study uses a piezo-electric crystal—generally a flat plate crystal of Rochelle salt stressed in bending by the acceleration forces acting on a small internal inertia mass when the unit itself is subjected to vibration—thus giving the pick-up an acceleration characteristic. The natural frequency is usually about 1500c/s. Crystal pick-ups are rather fragile, and for permanent use in engineering applications the less sensitive but more robust moving coil type is to be preferred.^{38, 40, 41} Two of the many devices for torque or torsional vibration measurement, one using the variable gap inductance detector and the other the wire resistance strain gauge—are illustrated in Fig. 15.

Mention may also be made of the R.A.E. serrated capacitor torsion pick-up¹⁷, designed for insertion in an aircraft propeller shaft; of the various "pressure heads"¹⁵ using capacitive or inductive detector elements c, d, e or i Fig. 14; and again of the many applications of photo-electric devices for displacement indication. In the last category, use is made in the vibration testing equipment illustrated in Fig. 3 (Part I), for example, of a photocell in conjunction with a pair of 100 lines per inch "gratings" to give absolute measurement of relative displacement by

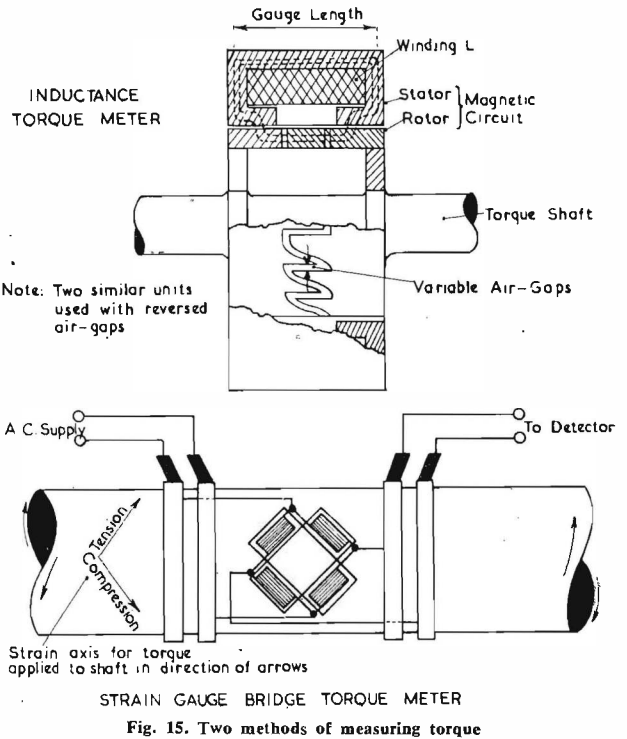

Fig. 15. Two methods of measuring torque

for indicating displacement, force, acceleration and allied quantities, any of the basic detector elements of Fig. 14 may themselves be used for special applications—permanent or experimental—and are frequently built-in to the machinery or structure on which measurements are required.

It is of interest, in passing, to note that all the displacement type transvertors shown may also be used as transducers, i.e., for conversion from electrical to mechanical energy. Thus the moving-coil detector becomes the loud-speaker unit, or in the industrial laboratory the vibration exciter. Such a unit, designed to absorb several kilowatts in its moving coil (of some 8 ins. diameter) was illustrated in Part I (Fig. 3). The simple electro-magnet, which may be used for the same purpose, corresponds to the variable inductance pick-up, while electrostatic vibration exciters have also been employed; the a.c. moving-coil detector may be considered the counter-part or the dynamometer watt-meter movement; the magnetostriction transducer and the quartz crystal, using the piezo-electric effect, are well established methods of inducing supersonic vibrations in metals.

TEMPERATURE INDICATING DEVICES

Referring again to Table I, perhaps the second most important class of detector device comprises those used for the measurement of temperature. There are at least three different types, in this category, which are dependent on the resistivity coefficients of different materials in addi-

"Hot" sources may thus be simulated by constant voltage inputs, if temperature is constant, or by constant current inputs where sources of constant thermal energy occur—as, for example, losses in electrical machine windings.

A simulator of this type is at present being applied to the evaluation of transient temperature conditions (and hence the resulting stresses) in such complex structures as gas turbine rotors and blading, and also to cooling problems in new types of alternators. A convenient feature of the analogy is that, by suitable choice of resistance and capacitance conversion constants, almost any desired ratio between thermal and electrical time scales may be obtained. Owing to the convenience of the cathode-ray oscillograph for transient response measurements, it is usual to make this choice such that the time taken to reach final temperature (which may be several hours in the thermal case) becomes of the order of 0.01 second. A recurrent oscillograph time sweep may then be employed to observe and record the "temperature" rise curve at each point in the network in turn, using suitable synchronized square wave "heat" inputs to the network.

In order to obtain practically useful results on complicated structures (for which, of course, the simulator is of greatest utility) subdivision into very large numbers of cells is essential and the network board itself must therefore be suitable for using large numbers of resistors and capacitors—though the individual accuracies of these components need not normally, be of the highest order. In the particular equipment that is shown in Fig. 13, plug-in wire-wound resistors and ordinary wire-ended paper capacitors are used, some 2,000 of the former and 3,000 of the latter being employed in a typical network. Two resistors in series or three paralleled capacitors, selected from stock standard values, are used to approximate to the specified value of each network element. The capacitors are, for convenience, located on the reverse side of the network boards.

The electronic control equipment, also seen in the photograph, includes 30 separate and independently adjustable voltage-regulated square wave input circuits (in 6-channel units) and 50 channels of specially designed "cooling simulators" which are used to reproduce the special conditions of air flow through cooling ducts. There are also a cathode-ray tube panel, time-base, and time marker unit in addition to power supplies and other auxiliaries.

DETECTOR DEVICES (TRANSVERTORS)

The last example must conclude our review of the many practical uses of electronic techniques in the engineering industry, in order that consideration may be given to some of the methods employed. In the field of industrial measurements, as distinct from that of telecommunications, the uses of electronic instruments depend very largely on the available "transvertors" or detector devices by means of which the various physical quantities to be studied may be converted into electrical signals. (The study of electrical phenomena in the electrical power industry is in this respect an exception.) These detector devices thus constitute the key to the whole range of electronic measuring apparatus: the diversity of their types and of the physical effects which may be utilized certainly accounts for the wide range of applications of electronics to measurement problems.

Between the point at which conversion of the measured quantity to an electrical signal takes place, and the meter or other device for utilizing the final electrical output, all of the highly developed technique of telecommunications engineering is available by means of which the information supplied may be modified, analysed or otherwise converted into suitable form for the purpose in hand. The design and manipulation of these "intermediate means" which, in fact, constitute the main occupation of the industrial

electronics laboratory, will form the substance of the remaining parts of this article. Meanwhile consideration will be given to the available forms of detector.

Various forms of classification for these devices have been proposed. They may be grouped electrically, for example, into those which generate their own E.M.F. and those which function as variable parameters— R , L or C —in an electric circuit; or according to the function which they serve in measurement. For the purpose of the present review this latter method will be adopted. Table I, though probably not complete, gives a list of at least the more important conversion devices or physical effects employed in electronic measuring systems, for rapid reference.

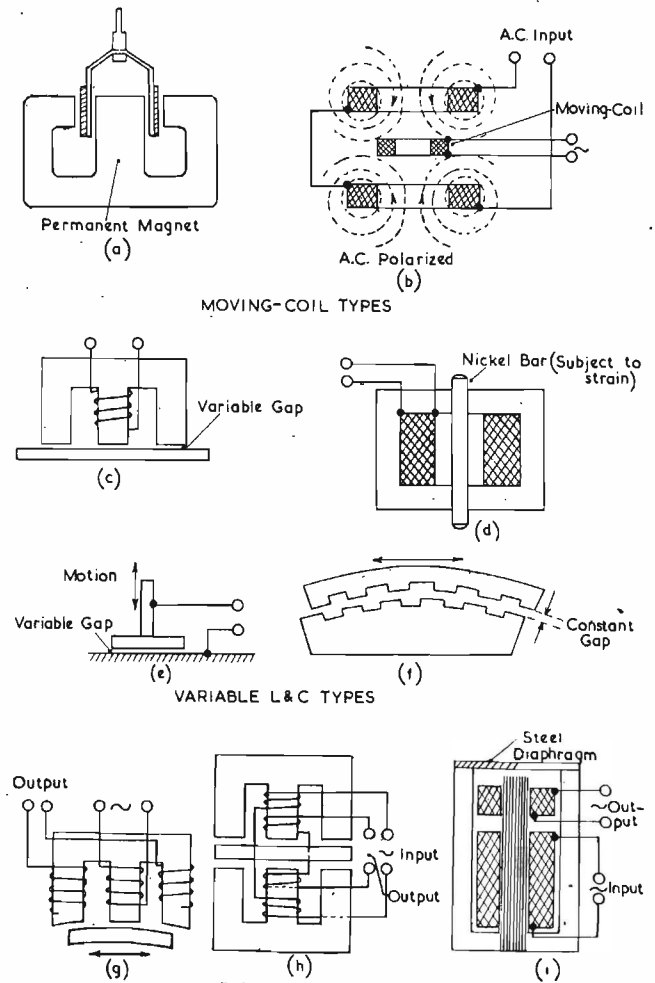

Fig. 14. Basic transvertor elements

"DISPLACEMENT" DETECTORS

A very important general class of detector device, which is accordingly given priority of place in the table, comprises all those which fundamentally indicate *motion*—i.e., relative displacement or velocity between two parts of the device: they include also those which serve indirectly for the measurement of force, pressure, acceleration, etc.^{2, 6, 38} Some of the basic elements which may be used in such detectors are illustrated in diagrammatic form in Fig. 14. These include detectors of the self-generating class, in the permanent magnet moving-coil pick-up (with which may be classed the piezo-electric crystal, not illustrated here), and also of the variable inductance^{10, 39} and variable capacitance types. They also include, in examples (g), (k) and (i), a group which may be styled "variable mutual inductance" and which depends for its

traced out, by traversing the probe manually in such a manner as to maintain zero signal at the output of the detector amplifier. The pantograph enables its path to be traced out accurately on the drawing board. Subsequently the plot is completed graphically, by drawing in the "lines of force" to form a rectangular orthogonal system with the experimentally determined equi-potential lines. As a refinement of this system completely automatic field plotting tanks have been made³³ by the addition of a motorized servo follower device.

Use of the electrolytic tank technique is not restricted to the direct representation of electro-magnetic fields. By virtue of an analogy which was recognized as far back as 1881 by Clerk Maxwell and others,³⁴ by which functions of a complex variable may be physically represented as potential distributions in a plane conducting layer, the method has been applied in practice to represent the impedance functions of electrical networks consisting of lumped parameters, such as those occurring in filter circuits, and has been utilized to determine both steady-state and transient response characteristics.³⁵

ELECTRICAL SIMULATOR NETWORKS

The third and last group of electrical analogies is that of the electrical simulator network. A number of electrical network calculating boards are in use in this and other countries for the more obvious direct application of solving current flow problems in complex inter-connected electrical systems such as that of the electricity "grid". Most of these are of the "model" circuit type.³⁶ One

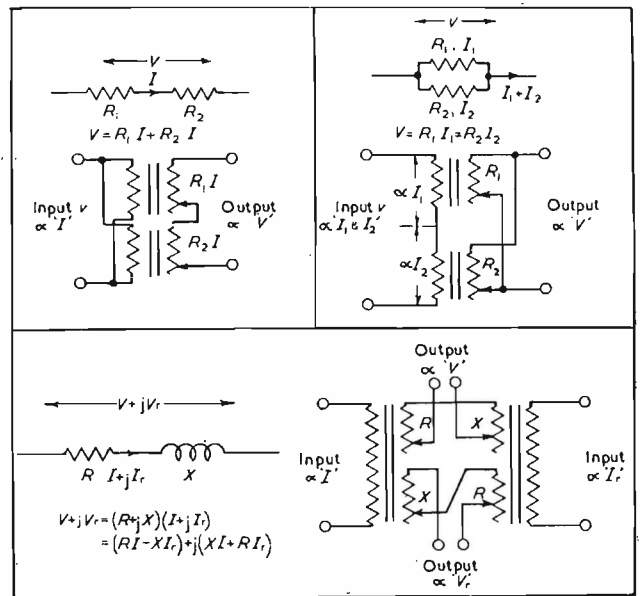

Fig. 12 (top). Resistors in series or in parallel (below) complex impedance ($R + jX$)

NOTE: Two separate 3-winding transformers with X and Y controls ganged, are used for each complex impedance, to deal with in-phase and reactive current.

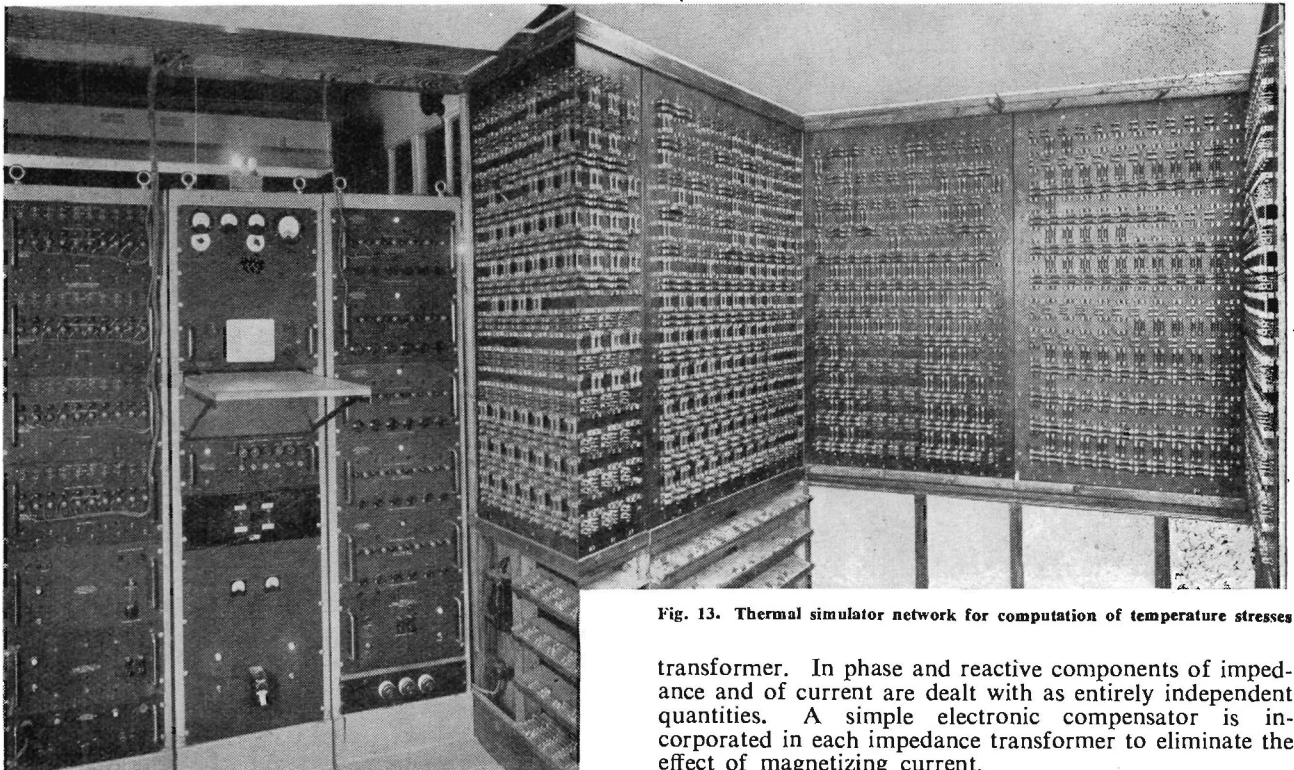

Fig. 13. Thermal simulator network for computation of temperature stresses

transformer. In phase and reactive components of impedance and of current are dealt with as entirely independent quantities. A simple electronic compensator is incorporated in each impedance transformer to eliminate the effect of magnetizing current.

such calculator,³⁷ however, is noteworthy on account of the somewhat unusual analogy which is adopted in which impedances (either resistance or reactance) are represented by transformers of variable ratio (Fig. 12): current in the impedance corresponds to the primary voltages, while voltage drops across them are represented by the secondary voltages. Thus like quantities are measured in the calculator for both "current" and "voltage", measurement being made very accurately in practice by comparison with the output of a "standard" voltage

Of more particular interest, from the point of view of electronic techniques, are the analogies by which electrical networks are employed to simulate thermal or mechanical problems.^{30,31} One such equipment designed for the former use will be described. In this analogy, electrical resistance and capacitance are used to represent the equivalent thermal quantities, values for individual unit "cells" of the structure under investigation being represented, to a suitable scale of values, by lumped parameters on the network board. Voltages and currents in the electrical system correspond to temperatures and rates of heat flow.

techniques have taken over work which was hitherto in the province of the mathematician.

COMPUTERS

The first of these covers the several different types of electronic calculators, employed for the purpose of solving mathematical equations, the complexity of which makes them either impossible, or too laborious, to solve by conventional methods. Of such equipments the most comprehensive and probably the best known, owing to the considerable publicity given to it in the Press, is the "Eniac" in America—a calculating machine of the digital type which employs some 18,000 electronic valves. Calculators of this class have been extensively developed in recent years, simpler and much more compact equipments having been produced on a commercial basis, and it appears that in the future they will find even wider application, in the business as well as in the scientific field.²⁷

Also in the category of electronic calculators are the

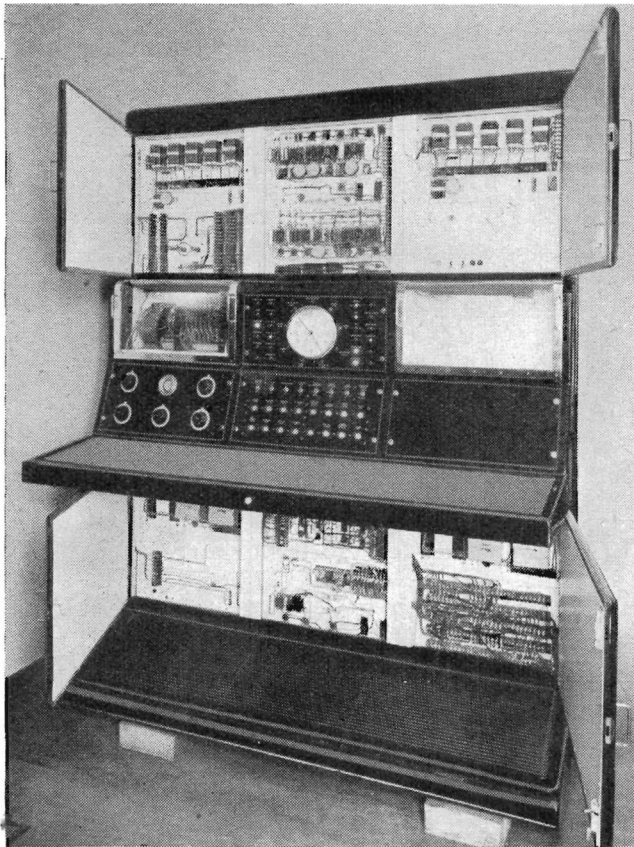

Fig. 10. Control console for a photographic zenith telescope for time determination

differential analysers and the electrical analogue computers. Both of these are of the "continuous" type: that is the variable under investigation is proportionately represented by a voltage or current or by a mechanical displacement. The former are used to solve differential equations of the higher orders, insoluble by normal mathematical methods. Information is fed in and taken out (in one type of analyser at least)²⁸ by means of pointers traversed in the "x" and "y" co-ordinates by lead screws, and made to follow, or to trace out, curves on a series of drawing boards. Integrations are performed mechanically by potter's wheel mechanisms incorporating photo-electric servo-follower arrangements.

The analogue computer, described in some detail in earlier issues of this journal²⁹ and elsewhere^{30,31,32} serves for the solution of more diverse types of mathematical

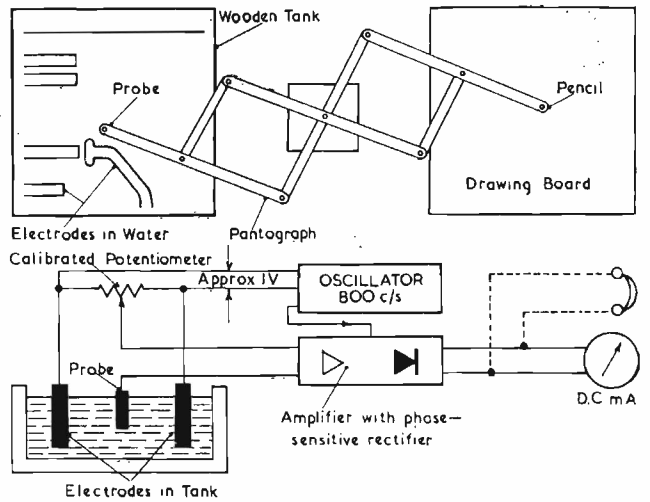

Fig. 11(a). Schematic diagram of electrolytic tank

problem. Many ingenious devices are employed to effect the various mathematical transformations involved, including the extensive application of the feedback amplifier principle. The solution may be obtained as an electrical signal (commonly displayed on a C.R.T.) or, in computers of the gun predictor type especially, as a shaft rotation produced by a servo-follower device.

THE ELECTROLYTIC TANK ANALOGY

The second group of electrical analogies alluded to above comprises the electrolytic tank techniques which are used, for example, for the plotting of complex electrostatic or magnetic field distributions. Fig. 11(a) shows diagrammatically the arrangement of a simple set-up for the former application and is largely self-explanatory. Either a parallel or a wedge-shaped section of the field to be investigated may be represented, as convenient. Metal electrodes are used to represent the conductors determining the actual field distribution in the prototype; the equivalent potential field is set up in the model by appropriate A.F. voltages applied to the electrodes. Ordinary tap water is suitable as an electrolyte, in an insulating tank. Using the measuring circuit shown, and with the reference potential adjusted in suitable steps, successive equi-potential lines in the field plot (Fig. 11(b)) may be

Fig. 11(b). Typical plot of dielectric field in H.V. transformer

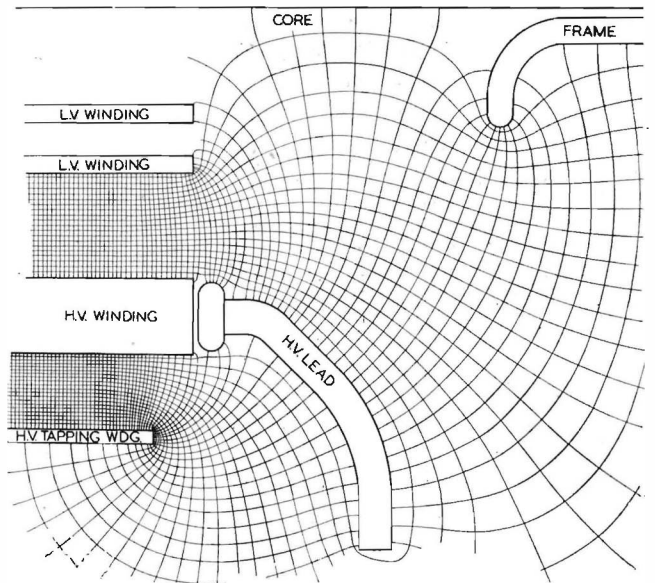

The Activities and Equipment of an Industrial Electronics Laboratory

(Part 2)

By G. H. Hickling,* B.Sc., A.M.I.E.E.

IN Part 1 of this article, reference was made to the development, by the Laboratory with which the writer is associated, of special electronic equipments for commercial production—generally as adjuncts to machinery or other engineering products manufactured in the factory. Among equipments in this category may be included the “supervisory” equipments for indicating and recording the mechanical performance of steam turbines in power stations and also a number of electronic instruments for use in chemical research, described in Part 1. One or two further examples of “production” equipments from the work of this laboratory will now be described which illustrate the application of electronics in less well-known branches of engineering.

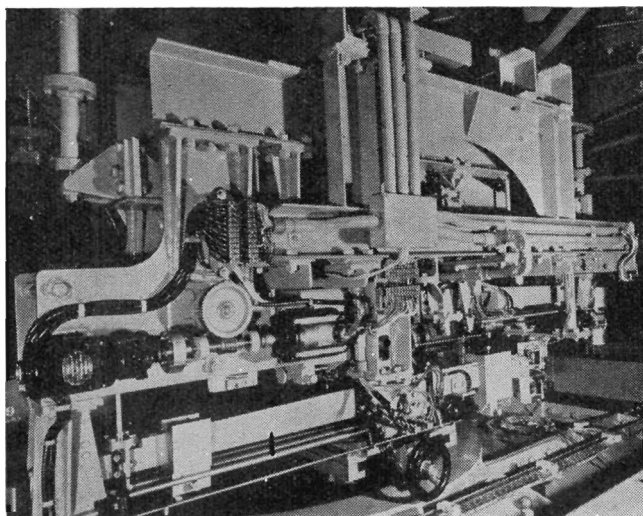

Fig. 9. Six-component wind tunnel balance

Aerodynamic Research

Fig. 9 illustrates one of several electronically controlled wind-tunnel balances²³ which have been built. This equipment, installed at the R.A.E., Farnborough, continuously measures the six components—three of force and three couples—acting on an aeroplane model under test, and gives remote indication of these quantities, with other information, in a control room outside the tunnel. Measurement, which is made by balancing the various forces on electronic servo operated weighbeams, is of a high order of accuracy—generally better, under steady conditions, than 1 part in 10,000 of maximum reading.

Astronomical Telescopes

The construction of large astronomical telescopes is another of the lesser known branches of high precision engineering. In this field, also, electronics finds its appli-

cations, the accurate guiding of large telescopes to permit long photographic exposures being one problem solved by such means. This may be done by means of a servo device using the star image itself, detected by a photocell, as the initiating means: such a system has, in fact, been developed²⁴⁻²⁵ giving high speed response up to several cycles per second to a photographic plate at the focus of the telescope for the purpose of cancelling out the effects of varying atmospheric refraction. More usually, however, as instanced by three 74in. reflecting telescopes now under construction, very accurate control of the mean rate of the telescope about its polar axis is provided. This is commonly done by a servo arranged to hold the driving motor in synchronism with an electrically maintained tuning fork; but more recently, improvements in the technique of stable frequency RC oscillators have led to the adoption of purely electronic frequency sources for this purpose, with the advantage that adjustment of rate can very easily be provided.

Of other recent applications of electronic methods in this field, one of outstanding interest is the control equipment for a photographic zenith tube to be installed in the new Greenwich Observatory at Hurstmonceaux.²⁶ The function of this new instrument is to record to a high degree of accuracy—approaching one millisecond—the times of transit of suitable stars across the meridian, relative to the Observatory's standard quartz-crystal clocks. It will thus serve ultimately to check the absolute standards of time upon which our radio time signals (and, incidentally, those of many other countries) depend. The control desk housing the main electronic equipment for this instrument is shown in Fig. 10. One of its special features is the method for maintaining the phonic motors, used to drive the photographic plate carriage, at a speed constant to 1 part in 50,000, yet meeting the further requirement of a controlled variation over a range of 2 per cent. Since this system may well have other applications, the principle employed may be of interest.

The controlling frequency is derived in part from a constant frequency, crystal-controlled 1,000c/s source, and in part from a very stable RC tuned oscillator variable between about 55 and 75c/s. An electronic frequency changer circuit is employed to add these two component frequencies so as to give a signal in which the proportional effect of any frequency drift in the variable oscillator (actually much better than 1 in 10,000) is reduced by about 14:1. The method used is effectively to split the 1,000c/s signal into a 4-phase system of quadrature components which are then fed through four separate amplifier stages. The lower frequency signal, after being similarly phase split, is used to gate these amplifiers in sequence so that during each low-frequency cycle, the 1,000c/s output is phase advanced by 90° four times in succession—i.e., one cycle is added, which will be seen to give the required result.

Electrical Computation—Use of Analogies

Before concluding this general survey, reference must be made to three fields of research in which electronic

* C. A. Parsons & Co., Ltd.

equation re-written as

$$A \times B = (a_1B + 2(a_2B + 2(\dots + 2a_pB) \dots))$$

The process can be programmed from the more basic operations of conjunction, shifting and addition, but built-in facilities (whether serial or parallel) are preferred to expedite this frequent operation and to take signs into account.

DIVISION

Division may be programmed by combining the above operations with discrimination in a routine of successive approximations. First, the reciprocal of the dividend B is obtained from the recurrence formula

$$x_{n+1} = x_n(2 - x_nB).$$

using a suitable initial constant x_0 . The iteration converges when $n = N$ (where N depends on the closeness of x_0 to $1/B$) and then,

$$x_{N+1} = x_N$$

with sufficient accuracy. Combining this with the recurrence formula, it is easy to see that

$$x_N = \frac{1}{B}$$

Allowing also for the final multiplication, about 0.1sec is required for programmed serial division.

Square roots can also be obtained by iterations, which involve the reciprocal.

These routines certainly take longer than the operation of circuits specially designed for them. Nevertheless, designers of universal machines in England favour them on the ground that circuits for discrimination are in any case required. The argument is debatable since only a small amount of extra apparatus is required to transform a multiplication circuit for division or square-rooting, whereas programming of these operations needs more temporary storage.

Digital and Analogue Systems

In England, the physical form of a computer is either an "analogue instrument" or a "digital machine" while the Americans contrast "continuous" and "discrete" computers. The classifications are convenient, but their suggestiveness calls for further discussion of the representation and manipulation of numbers. The relevant properties are form, continuity and structure, the latter being the most important.

As an example of form, a time interval of 7 microseconds could be represented as 7 millivolts (analogue) or as the pulse group 0111 (binary digital) by way of an encoding process resembling amplitude modulation in one case and pulse code modulation in the other. Subsequent operations are affected by the chosen form; whereas various physical laws serve "analogue" computation (e.g., CR networks for integration and differentiation), the "digital machine" operates with the more abstract and human methods of numerical analysis. However, in solving a physico-mathematical problem, the computer, regardless of its classification, acts as a model of the problem, i.e., of a physical situation,²⁰ and this is, of course, the customary meaning of the word "analogue."

With regard to the continuum of the natural numbers, as illustrated in Fig. 2, let the quantity to be encoded have some value between 7 and 7.25 microseconds. In the digital computer, only a finite number of digital places is available. For example, if 0111.0 represents any value between 6.75 and 7.25, this amounts to truncating a natural number so as to yield a rational number or finite fraction. In this case also, "analogue" representation is similar; the physical representation of an infinite fraction would imply infinite accuracy which is impossible because of engineering tolerances for backlash, etc., and ultimately because nature is quantal (uncertainty principle).

The salient distinction between "analogue" and "digital" systems lies in the number of digital places, of

which the latter has a plurality and the former only one. The analogue form may be regarded as a special case of the digital in which there is only one digital place and the radix (= number of digital symbols) is equal to M , the largest number which can be represented. In this case, the accuracy is $1/M$; e.g., the granularity of a 1,000 turn potentiometer yields $M = 1,000$. Analogue systems are single-place digital systems, and there is no distinction between serial and parallel modes. Consequently, operation is simplified because only one digital place has to be dealt with, but operation is also complicated because this single place may be filled in M different ways, compared with only two ways in the extreme case of a binary system.

Now, to take M as small as 2 may be extravagant in many instances, such as the anode current of a valve. However, it is always true that just as any physical signal is subject to noise, so any computing device suffers from errors, as distinct from mistakes, for the following reasons.

Feeding the device usually causes errors because only a finite number of states are possible at the outset.

Every arithmetical operation is ultimately followed by increased error because, in digital (low radix) working, the word length increases and must usually be reduced to the normal value before the next arithmetical operation, while in analogue working, this extra length is implicitly suppressed because it would have to be represented by symbols denoting fractions less than $1/M$ of the maximum number and these are submerged by the equivalent of noise.

The accuracy of an analogue system is governed by the precision of its component parts. Increasing the accuracy is the same as increasing the radix and this process becomes increasingly difficult and expensive in a given case. In a digital (low radix) system this does not occur since the accuracy, i.e., the number of digital places may be readily increased. With the serial mode, this requires only extra storage length and time.

Hence, it is clear that the choice of system becomes problematical only where a simple analogue system is almost good enough and when it is possible to modify it to meet the specification. If the necessary modifications involve considerable quantities of extra equipment, a digital system may be preferable; if flexibility is required as well as high speed and accuracy, a universal machine based on digital techniques must be used. In fact, these techniques have hitherto been confined mainly to universal machines.

In conclusion, the useful class of "analogue-digital" computers will be mentioned. To give an example, the rational operations $+$, $-$, \times , \div may be instrumented by means of a Wheatstone bridge if the impedances of the arms represent the numbers. Decade boxes are often used, and the system is then apparently digital. However, the operation is of analogue form, since, even with a perfect balance, the accuracy depends on the precision of each arm relative to the total. If the operation were digital, absolute accuracy would obtain if each decade were accurate to just better than one part in 18 of that decade. Nevertheless, analogue methods can be made more precise by substituting discrete for nominally continuous parameters.^{20, 21}

Acknowledgments

Thanks are due to E.M.I. Engineering Development Ltd., for permission to publish this article, which is a revised form of an E.M.I. report issued at the end of 1949, and to Mr. R. E. Spencer for helpful discussions and for suggesting the section comparing digital and analogue computers.

REFERENCES

- ⁹ TUNG CHANG CHEN, Diode coincidence and mixing circuits in digital computers. *Proc. I.R.E.* 38, 511 (1950).
- ¹⁰ MURRAY, F. J. Theory of mathematical machines. (King's Crown Press, New York 1948).
- ²¹ LIEBMAN, G. Solution of Partial Differential Equations with a Resistance Network Analogue. *Brit. J. of Appl. Phys.* 1, 92 (1950).

4 to 5, the successors of 5 are counted, and the desired sum is the fourth of these. It is, however, more usual to refer to the short addition tables, mostly stored in our memories since infancy.

In the binary scale there are two digit symbols only, hence only two successors: "0" is followed by "1", "1" by "0" and "carry"; the short addition table is identical with the rule for counting.

A "Half-Adder" adds together two digits in the same place, say r . The output of this circuit must be the sum, a two Δ number (in which the symbol " Δ " means "digit"), in places r and $(r + 1)$. The first truth table of Fig. 9 gives the required laws which, on referring to Fig. 5, are seen to be

$$r^{\text{th}} \text{ place } \Delta = (a_r \neq b_r),$$

$$\text{carry } \Delta = (a_r \cdot b_r),$$

resulting in the first logical circuit shown. This may be simplified to the alternative circuit on noting that the law for the r -place Δ also obeys the less simple relation

$$r^{\text{th}} \text{ place } \Delta = ((a_r \vee b_r) \cdot \sim(a_r \times b_r)).$$

The "Full-Adder" forms the serial sum of two serial words; one half-adder no longer suffices because in any digital place other than the lowest, a third input may be present owing to a carry over. The corresponding truth table also appears in Fig. 9. Allowing for permutations, this is only an extension of the preceding one; hence two

NAME, FUNCTION	TRUTH TABLE	LOGICAL CIRCUIT																														
Half-adder forms sum of two digits in same place r	<table border="1"> <thead> <tr> <th colspan="2">IN</th> <th colspan="2">$a_r + b_r$</th> </tr> <tr> <th>a_r</th> <th>b_r</th> <th>r^{th} Place</th> <th>Carry</th> </tr> </thead> <tbody> <tr> <td>0</td> <td>0</td> <td>0</td> <td>0</td> </tr> <tr> <td>1</td> <td>0</td> <td>1</td> <td>0</td> </tr> <tr> <td>0</td> <td>1</td> <td>1</td> <td>0</td> </tr> <tr> <td>1</td> <td>1</td> <td>0</td> <td>1</td> </tr> </tbody> </table>	IN		$a_r + b_r$		a_r	b_r	r^{th} Place	Carry	0	0	0	0	1	0	1	0	0	1	1	0	1	1	0	1							
IN		$a_r + b_r$																														
a_r	b_r	r^{th} Place	Carry																													
0	0	0	0																													
1	0	1	0																													
0	1	1	0																													
1	1	0	1																													
Full-adder forms sum of two serial words	<table border="1"> <thead> <tr> <th colspan="3">IN</th> <th colspan="2">$(A + B)$</th> </tr> <tr> <th>a_r</th> <th>b_r</th> <th>c_r</th> <th>r^{th} Place</th> <th>Carry</th> </tr> </thead> <tbody> <tr> <td>0</td> <td>0</td> <td>0</td> <td>0</td> <td>0</td> </tr> <tr> <td>1</td> <td>0</td> <td>0</td> <td>1</td> <td>0</td> </tr> <tr> <td>1</td> <td>1</td> <td>0</td> <td>0</td> <td>1</td> </tr> <tr> <td>1</td> <td>1</td> <td>1</td> <td>1</td> <td>1</td> </tr> </tbody> </table> <p>Permutations not shown</p>	IN			$(A + B)$		a_r	b_r	c_r	r^{th} Place	Carry	0	0	0	0	0	1	0	0	1	0	1	1	0	0	1	1	1	1	1	1	
IN			$(A + B)$																													
a_r	b_r	c_r	r^{th} Place	Carry																												
0	0	0	0	0																												
1	0	0	1	0																												
1	1	0	0	1																												
1	1	1	1	1																												

Fig. 9. Additional circuits

half-adders must be used, or one half-adder must be augmented by a gate of threshold 3 to cope with the new case $1 + 1 + 1$. The carry is obtained by the "2" element and, after a delay of 1 digit place, becomes the third input to the circuit. Note that the "1" and "3" have their outputs joined together because they cannot both have an output at the same instant; when the "3" has an output, the "2" is stimulated and this in turn inhibits the "1". Usually, provision is made to suppress the carry arising from the highest digit place, since $2^p = 0 \pmod{2^p}$.

The time taken by a serial addition is 1 minor cycle, i.e., about 35 microseconds, assuming the equivalent of a ten digit decimal number and a pulse repetition period of 1 microsecond.

Example

A	00100	4
B	00111	7
$A + B$	01011	11
Carries	1	

SUBTRACTION.

As mentioned previously, this may be dealt with by the method of complements; for

$$n_{(A-B)} = n_A + n_{(M-B)}.$$

Since, usually, B arises in the form n_B , the problem is reduced to finding the word $n_{(M-B)}$ representing the complement of the number B given by n_B .

On setting $A = B$ in the above equation, clearly $n_B + n_{M-B} = 0$ since $n_0 = 0$ in the convention.

To find $n_{M-B} = -n_B$, note that on applying the "law of excluded middle" to every digital place,

$$n_B + (\sim n_B) = M - 1 \text{ which is a string of "ones";}$$

hence

$$n_B + (\sim n_B) + P_1 = M = 0 \pmod{M}, \text{ where}$$

the "fugitive digit" 1 is represented by P_1 , the clock pulse at the time when the digital weight is 2^0 .

$$\text{Finally, } n_{M-B} = -n_B = (\sim n_B) + P_1.$$

Hence the subtrahend need only be applied to the inhibitor terminal of a gate energized by the clock; the output is taken to the adder, together with the minuend A ; the fugitive digit P_1 is applied to the third input line of the adder, which is then available since no carry digit arrives at P_1 time (Fig. 10).

Example

B	00111	7
A	00100	4
$\sim B$	11000	-8
$A - B$	11101	-3

Check: $-16 + 8 + 4 + 1 = -3$.

TRUTH TABLE

b_r	$\sim b_r$	$b_r(\sim b_r)$
0	1	1
1	0	1

$B + \sim B = (M-1)$

LOGICAL CIRCUIT(SERIAL)

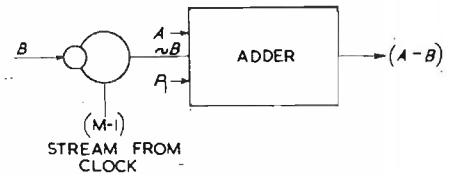

Fig. 10. Subtraction circuit

MULTIPLICATION

Where the multiplier is an integral power of the radix, multiplication is a shift to the left. In the binary system and serial mode, an extra delay of r digit periods amounts to multiplication by 2^r , where r is a positive integer and the product is small enough; to divide by 2^r the number is delayed by an extra $(p-r)$ digits with due attention to the sign of the quotient.

Given more general factors A, B , the product is developed in an accumulator, that is, in a store with addition facilities such that the number just inserted is added to the contents. This multiplication by repeated addition is expressed as

$$A \times B = \sum_{r=1}^p a_r 2^{r-1} \cdot B.$$

where each partial product arises as either 0 or B since a_r is either 0 or 1; successive bits a_r of the multiplier A gate the multiplicand B into the accumulator; every new a_r must be accompanied by one shift of B relative to the partial total in the accumulator to satisfy the above

are more elaborate of course, but may be based on crystals¹⁰ rather than valves.¹¹

Electrical circuits are too detailed in the earlier stages of study or design. It is then useful to have "logical circuits" of the elements of Fig. 5 (column 3) augmented by the symbols of Fig. 6. Of the latter, only the unit time delay is essential, the rest are composite. Thus, a trigger is logically equivalent to a gate with feedback via a unit delay, though an Eccles-Jordan circuit can be used in those circumstances where its D.C. output is as useful as a stream of pulses.

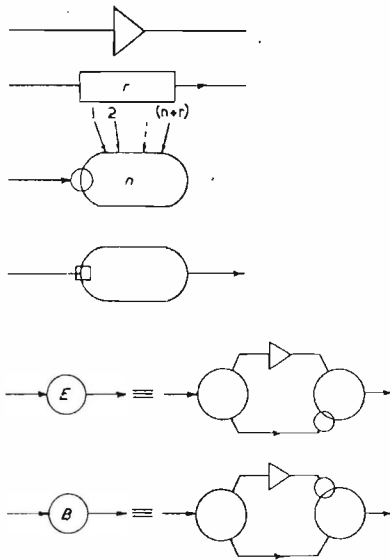

Fig. 6. Further logical symbols

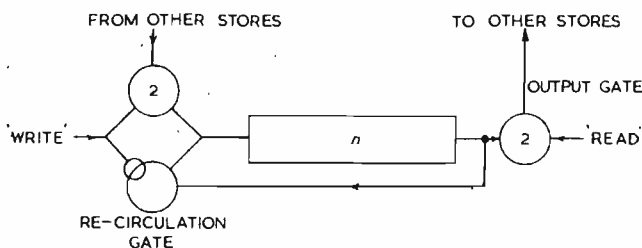

Fig. 7. Dynamic store with terminal gates

A first instance of a logical circuit is presented by Fig. 7, a dynamic store with its terminal gates. The output gate is opened as long as a train of "read" pulses is supplied by "control"; similarly the "write" instruction opens the input gate and clears out the old contents by inhibiting the re-circulation gate. (Timing and multi-way switching networks in control ensure that the appropriate gates are energized for the required time.)

Arithmetic and Logic

If a numerical problem has a finite solution, a pulse-coded computer can be programmed to find it, because

- (a) numerical mathematics is reducible to arithmetic;
- (b) arithmetic is reducible to a single arithmetical operation and logic;
- (c) logic operates with the binary quantities 0 and 1.

The basic science of digital computers may be regarded as "Quantitative Logic", a combination of ordinary and

binary numbers, the former obeying the laws of ordinary algebra and the latter the laws of Boolean algebra.

Example

The instructions for programmed division may be summarized thus:

if C is negative, multiply D by A ,

if C is positive, multiply D by B , deduct from 2 and multiply by D ;

the expression

$$(c_p \times [D \times A]) \vee ((\sim c_p) [D(2 - D \times B)])$$

is still more brief and closer to machine language. The letter symbols refer as usual to storage locations. Eventually, bit c_p will be 1, the contents of D and B will be reciprocals and the expression then refers to the quotient A/B .

Note that only one of the terms on either side of the " \vee " will differ from zero since either c_p or $\sim c_p$ vanishes; thus the " \vee " behaves like the common "+", but it is to be preferred since selection from the square bracket pair depends on the binary quantity c_p alone. However, the chosen term is a real number.

Word digits are themselves amenable to logical operations. The only feature which is not binary (= logical, in this sense) is then the digital place. Digit place or "weight" is represented by time delays in the serial case, and by p -fold repetition of operational apparatus in the parallel case; in the latter case some short-time delays are also required, for carry-over purposes.

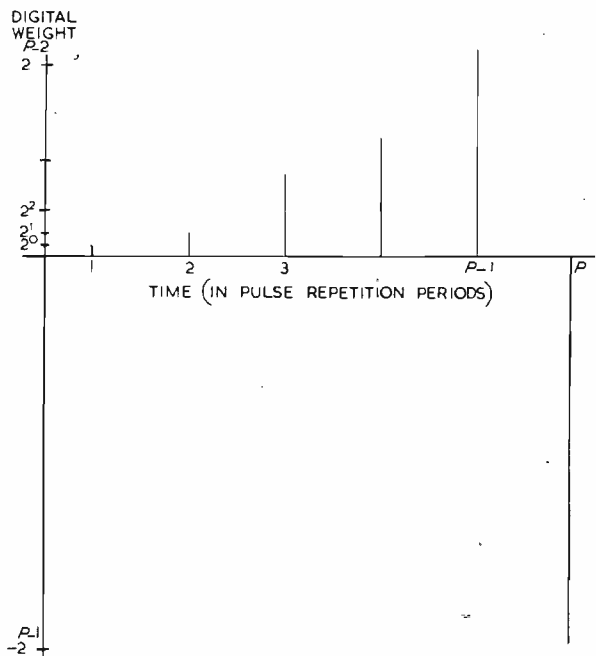

Fig. 8. Digital weights

The representation of words (binary numbers in the complements code) by a time series of pulses is illustrated by Fig. 8, the pulse amplitude is, of course, constant, i.e., 0 or 1. Time is shown as increasing from left to right, by the usual convention. This, however, has the effect of placing the binary point to the left, e.g., $-4 = 0011$; although not uncommon in the specialized literature, this is the opposite of normal practice, which would lead one to expect $-4 = 1100$.

Arithmetical Operations

ADDITION

The serial mode will be assumed for convenience of illustration. This operation is based on counting. To add

On the Background of Pulse-Coded Computers

(Part 2)

By T. J. Rey,* M.A., B.Sc., A.M.I.E.E.

Mathematical Logic (Boolean Algebra)

This discipline is important in digital computers because it deals with quantities which can have only one out of two possible states, "true" or "false", "1" or "0"; i.e., with binary numbers (as distinct from numbers expressed in binary notation). Moreover, it can be shown that any arithmetical operation is reducible to a single primitive in arithmetic, e.g., addition, and to logical operations. Again, all logical operations can conveniently be reduced to three operations or so (and to a single primitive in theory).

These logical operations are thus of the utmost practical importance. They are termed conjunction, alternation and denial. They are completely defined in the first two columns of Fig. 5. Name, symbol(s) and pronunciation are given first. The second column contains their "truth tables", the classical method of definition.

Taking the truth table for conjunction, the outer columns list A and B , respectively, such that the four rows yield all the possible combinations of A and B . The central column contains the corresponding values of $(A.B)$. This is "true" in the single case where both A and B are "true", "false" if either or both are "false".

Similarly, alternation is "false" in the one case when both A and B are "false"; it is true whenever either or both of A, B are "true".

Denial operates on a single quantity; "not A " is "true" when A is "false", and vice versa.

There is no need to remember the definitions; conjunction simply corresponds to multiplication (conjunctive, i.e., non-exclusive), alternation to addition (if it be agreed to take the result as "1" if the sum is "2"), and denial is obvious. This explanation is not a definition and must be taken with care; e.g., the number "2" does not actually exist in Boolean Algebra; in other binary contexts, "2" is often taken as "0" or "0 + Carry".

(Boole originated this algebra by treating Aristotelian logic mathematically. For example, the "law of excluded middle" or " $A + \sim A = 1$ " follows on inspection of the truth table for denial.)

The third column of Fig. 5 exhibits the appropriate "Logical Elements" devised by Turing. An "element" is a gate having its output equal to either 0 or 1; it is drawn as a circle and the inscribed number denotes the threshold or number of inputs needed for an output 1. No number is normally given if the threshold is 1, nor is it good practice to use thresholds larger than 2. Inputs are either 0 or 1. As shown, for denial a "1" element is stimulated by a 1 (pulse from clock) at the time when A is applied to its "inhibitor" terminal, a tiny circle; the output is then " $\sim A$ ".

Although any logical operation may be built up from these three operations, this is not always the simplest procedure. For instance, the non-equivalence of A and B may be expressed in the form

$$(A \vee B) \cdot (\sim (A.B))$$

However, it is more satisfactory to use the logical elements in the fourth row for this purpose than to combine the others suitably.

The last column of Fig. 5 shows crude electrical circuits for the logical elements; assuming pulse voltages equal to the grid base, different bias conditions allow much the same circuit to be used in all cases. The inverting valve needed in the first circuit is not shown. Practical circuits

Fig. 5. Illustration of logic

NAME & SYMBOL	TRUTH TABLE	LOGICAL ELEMENT	CIRCUIT SCHEMATIC & CHARACTERISTIC															
CONJUNCTION $A.B$ also $A \wedge B$ Spoken: 'A and B'	<table border="1"> <tr><td>A</td><td>A.B</td><td>B</td></tr> <tr><td>0</td><td>0</td><td>0</td></tr> <tr><td>1</td><td>0</td><td>0</td></tr> <tr><td>0</td><td>0</td><td>1</td></tr> <tr><td>1</td><td>1</td><td>1</td></tr> </table>	A	A.B	B	0	0	0	1	0	0	0	0	1	1	1	1	<p>2 Element</p>	<p>Operating Point 2x Pulse Height</p>
A	A.B	B																
0	0	0																
1	0	0																
0	0	1																
1	1	1																
ALTERNATION $A \vee B$ (Note: Vel is latin for 'either or both of the two') Spoken: 'A or B or both'	<table border="1"> <tr><td>A</td><td>A v B</td><td>B</td></tr> <tr><td>0</td><td>0</td><td>0</td></tr> <tr><td>1</td><td>1</td><td>0</td></tr> <tr><td>0</td><td>1</td><td>1</td></tr> <tr><td>1</td><td>1</td><td>1</td></tr> </table>	A	A v B	B	0	0	0	1	1	0	0	1	1	1	1	1	<p>1- Element</p>	<p>Circuit as above</p> <p>Operating Point</p>
A	A v B	B																
0	0	0																
1	1	0																
0	1	1																
1	1	1																
DENIAL $\sim A$ (Note: The tilde \sim stands for the first letter in 'not') Spoken: 'Not A'	<table border="1"> <tr><td>A</td><td>$\sim A$</td></tr> <tr><td>0</td><td>1</td></tr> <tr><td>1</td><td>0</td></tr> </table>	A	$\sim A$	0	1	1	0	<p>1- Element with inhibitory connexion</p>	<p>Operating Point</p>									
A	$\sim A$																	
0	1																	
1	0																	
NON-EQUIVALENCE $A \neq B$ Spoken: 'A not equivalent to B'	<table border="1"> <tr><td>A</td><td>$A \neq B$</td><td>B</td></tr> <tr><td>0</td><td>1</td><td>0</td></tr> <tr><td>1</td><td>0</td><td>1</td></tr> </table>	A	$A \neq B$	B	0	1	0	1	0	1	<p>2 Element</p>							
A	$A \neq B$	B																
0	1	0																
1	0	1																

* E.M.I. Engineering Development Ltd.

Technical Terms:

- B.S. 204 : 1943—Glossary of Terms used in Telecommunications. Five supplements : (1) Waveguide Technique.
 (2) Radio Propagation.
 (3) Fundamental Radio Terms.
 (4) Radar.
 (5) Piezo-electric Terms.

B.S. 205 : 1943—Glossary of Terms used in Electrical Engineering.

- B.R. 1897B (Admiralty) } This inter-Services book—issued by each
 E.M.E.R. Tels. A305 (Army) } Service under its own reference—is
 A.P. 2867B (Air Ministry) } B.S. 204: 1943 without the Supplements.
 B.R. 1897A (Admiralty) } This inter-Services book—issued by each
 E.M.E.R. Tels. A306 Issue 2 (Army) } Service under its own reference—includes
 A.P. 2867A (Air Ministry) } nearly all that is in Supplements (1), (3)
 and (4) of B.S. 204: 1943.

Note.—The Admiralty issue B.R. 1897A and B.R. 1897B bound as one volume B.R. 1897. Service personnel and commercial concerns having contractual relations with the Government will find all except certain radio propagation and piezo-electric terms in the Service books mentioned. Others should use B.S. 204: 1943 plus the Supplements.

Circuit Presentation and Drawing Office Practice:

- B.S. 530 : 1948—Graphical Symbols for Telecommunications. Two Supplements:
 (1) Component References.
 (2) Waveguide Symbols.

B.S. 108 : 1951—Graphical Symbols for General Electrical Purposes.

B.S. 308 : 1943—Engineering Drawing Office Practice.

- B.R. 1079 (50) Part I (Admiralty) } This inter-Services book—issued by each
 E.M.E.R. Tels. A301 Issue 4 (Army) } Service under its own reference—covers
 A.P. 2867 (Air Ministry) } the same ground as B.S. 530: 1948 and
 agrees with it, but gives Service prefer-
 ences; it contains B.S. 530 : 1948
 Supplement (1) and the material in
 Supplement (2).

Note.—Service personnel and commercial concerns having contractual relations with the Government will find what they require in the Service books mentioned. Others should use B.S. 530 : 1948 plus the Supplements.

Miscellaneous References:

- Authors' and Printers' Dictionary by F. H. Collins (Oxford University Press).
 London School of Printing.—L.S.P. Style of the House. 6d.
 London Mathematical Society.—Notes on the Preparation of Mathematical Papers. 1s.
 Institute of Physics.—Notes on the Preparation of Contributions to the Institute's Journals and other publications. 2s.
 Institution of Electrical Engineers.—Handbook for Authors. 2s.
 Royal Society.—General Notes on the Preparation of Scientific Papers. 2s. 6d.

An Electronic Voltage Stabilizer with Self-Regulated Heater Supply

By C. Morton,* B.Sc.

IF the power supply required to heat the cathodes of the valves used in an electronic voltage regulator is derived from the unstabilized input voltage, fluctuations in cathode temperature due to changes in the input voltage give rise to variations in the current through the load; for

stabilized output of 100mA at 400V, Scroggie² states that the application of a sudden mains voltage change of ± 10 per cent produced at first only a change of about ± 15 mV in the output voltage, but this was followed by a slow drift of as much as 800mV due to change in the power supplied to the heaters of the valves. Johnston³ eliminates this effect by providing a stabilized cathode heater supply from an independent source. A more economical arrangement, applicable in cases in which the mains unit is used to deliver power to a constant load, is that shown in Fig. 1.

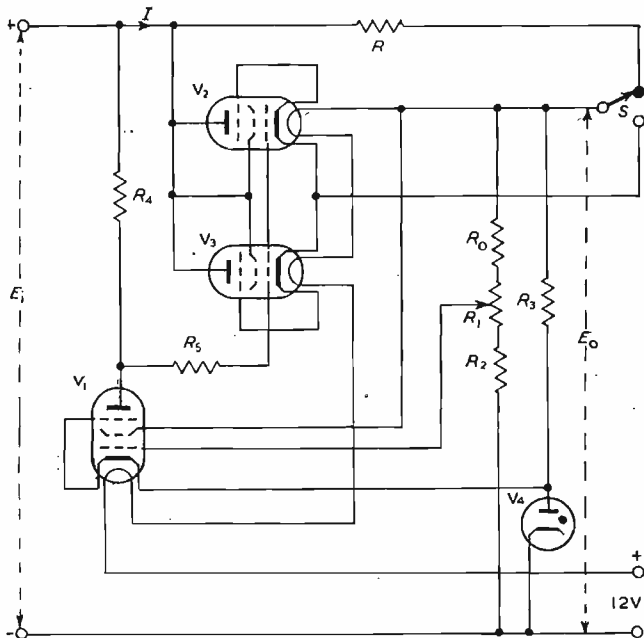

Fig. 1. Series thermionic stabilizer with self-regulated cathode heater supply

V_2, V_3	UL41	R_4	1m Ω
V_4	85A1	S	Single - pole, two - way switch, Q.M.B.
R	2,000 Ω , 30W.	E_1	333V.
R_0, R_1, R_3	50k Ω	E_0	124V.
R_2	100k Ω	I	104.5mA.
R_5	10k Ω		

example, in describing the performance of a series thermionic regulator¹ designed to deliver a maximum

Many of the potentiometric pH meters⁴ used in this country require a stable d.c. supply of 100mA at 12V, and the circuit of Fig. 1 was designed to deliver power to a 120 Ω resistive load of this type. The heaters of the valves are connected in series with the load, thereby constituting part of the output circuit across which the stabilized output voltage E_0 is developed. During the preliminary heating of the cathodes, the parallel-connected valves V_2, V_3 are disconnected, by means of the switch S , from the control circuit, the current I being diverted through the equivalent ohmic resistance R . The value of this resistance is given by $R = V/I$, where V is the p.d. between the anodes and cathodes of V_2 and V_3 when functioning as control valves. When the cathodes of the valves have attained their normal operating temperatures, the switch is thrown to its alternative position, and regulation commences. The manually-operated switch may be replaced by a thermal delay switch of suitable type. In contrast to the behaviour of the stabilizer described by Scroggie,² the application of a sudden mains voltage change produces a rapid change in output voltage followed by a gradual recovery, the latter being completed in about 30 seconds: using the circuit values given in the diagram, the permanent change in E_0 for a change in E_1 of ± 10 per cent is approximately ± 40 mV. The method of self-regulation of the cathode heater supply described in this note is readily applicable to shunt stabilizers and to electronic voltage regulators of other types.

REFERENCES

- ¹ HUNT, F. V., and HICKMAN, R. W. : *Rev. Sci. Instrum.* 10, 6 (1939).
² SCROGGIE, M. G. : *Wireless World*, *liv.* 416 (1948).
³ JOHNSTON, D. L. : *Wireless Engr.*, 24, 231 (1947).
⁴ MORTON, C. : *J. Sci. Instrum.*, 9, 289 (1932); MORTON, C. and BEST, F. L. : *J. Soc. Chem. Ind.*, 52, 6T (Jan. 13, 1933).

* Chelsea Polytechnic.

3 db, but other numbers up to a hundred should be denoted by words (four screws, fifty-seven varieties, but 101 varieties, 150 valves). Tables should be separately numbered (e.g. Table 4). Roman numerals have lost their gentility and even Service "Mark" numbers are now in arabic numerals; the decline and fall of the roman numeral is emphasised by permitting its inglorious use for sub-paragraphs. The solidus (i.e. oblique-stroke) should be reserved for ratios; R/F, D/F, etc. are not permissible. Measurements in the text should use abbreviations (ft, in, cm) not signs. Full-stops are not inserted between a component's letter and number (C.1 is wrong); it is CV.1264, not C.V.1264.

Spelling is a highly controversial issue and a writer is at the mercy of the printer. The use of -ize instead of -ise where -ize derives from the Greek (e.g. realize, recognize, economize) is enforced by many learned societies and by many printers. (Analyse, advertise, devise, revise are spelt as shown.) They also often enforce the spelling connexion, deflexion, inflexion, reflexion. The I.E.E. deprecate this but rather fancy -ize. The history of terms of two words follows a recognised course: (1) separate words (2) hyphenated words (3) words joined together, e.g. headmaster, waveguide. Under American influence, the junction of words is being accelerated. There is a strong tide flowing in favour of the ending -tor instead of -ter for instruments such as adaptor, convertor. It is now widely agreed that double consonants should be avoided in words like biased, focused, riveted, pivoted, jacketed. Spell viz. *namely* (which is how it is pronounced). Omit a comma after i.e. and e.g.

The widest adjectival use of the abbreviations A.C. and D.C. is, as a matter of convenience, advocated by most engineers. The I.E.E., however, puritanically deprecate D.C. voltage, A.C. current, and impose long clumsy spelt-out alternatives which rob the abbreviations of almost all their value; the I.E.E. authority does not extend beyond the pages of their journal. The Inter-Services Glossary of Terms used in Telecommunications 1949 speaks cheerfully of "D.C. or A.C. voltage".

Few will object to the standard graphical symbols to be used in circuits. Those who are not up-to-date in these matters should note particularly the symbols for switches, plug and socket, screw links (e.g. transformer tappings for different mains voltages), fuse, vibrator, gas-filled tube, beam tetrode, C.R.T. with magnetic deflection and focusing, electrolytic capacitor, rectifier, valve heaters, coaxial pair and all waveguide symbols. These are commonly drawn incorrectly. Note that a metal rectifier is no longer drawn like a crystal detector (only half the solid triangle is now drawn). The lettering of some components has also been altered; thus the designation for an aerial is AE, for a transformer TR, for a potentiometer RV, for a battery BY, for a rectifier MR. The rules relating to the labelling of ganged switches should be noted (SWAa, SWAb, etc.). All electronic devices are labelled V; thus a diode should not be marked D2 or a cathode-ray tube CRT2. Values of components should be added if this is helpful and if there is room.

Diagrams are classed as circuit diagram, block diagram, wiring diagram (enables wiring to be traced but does not show the physical arrangement of the wiring), wiring layout (shows physical layout of wiring), component layout (a component-locating diagram to show the whereabouts of the various components), functional diagram, servicing diagram (might show waveforms and test-voltages). The noun "schematic" is taboo; as an adjective, this pretentious word is almost always meaningless and unnecessary. A simplified circuit is one which shows the essentials for explanatory purposes, some components and/or connections being omitted.

Diagrams should be drawn so that the main sequence of cause to effect goes from left to right. Thus, the aerial of a receiver would be on the left, but the aerial of a trans-

mitter would be on the right. The best arrangement of valves in a complicated diagram needs careful thought. The main process must be first clearly visualised. Subsidiary circuits (e.g. a local oscillator or A.G.C. valve) should be drawn outside the main signal chain (preferably below it). There may be no medical term for a "fear of white spaces", but the disease exists; there is no virtue in arranging a circuit so that all the space is nicely filled. On the other hand, a fairly balanced composition can often be achieved without loss of clarity; for example, successive valves in a chain should preferably be of the same size and on the same level. A heavy earth-line (with an earth symbol attached) should usually be drawn, connections to it being drawn not as dots (which would be too large) but as filled-in semi-circles. In general, positive voltage points should be above the earth-line and negative voltage points (e.g. negative bias) below it. Anode, S.G. and cathode resistors are arranged vertically. Earth symbols may be arranged at any angle or even upside-down; this is Post Office practice but rather unusual in radio circuits; "abnormal" earths are useful in cramped or complicated circuits but are usually unnecessary.

The most important change in circuit-drawing relates to junctions and crossings. The semi-circular bridge is definitely "out" (unless essential for clarity) and wires simply cross each other (without a break). Junctions (as distinct from crossings) are represented by dots where lines join, but in no circumstances must two lines crossing at right-angles meet at one dot. This is to prevent confusion if the dot were omitted by the draughtsman or became lost in the printing; the lines would then look as though they were crossing. Where formerly four lines met at a dot to form right-angles, one line must now be joined a short distance away; alternatively, one line can approach the dot in such a way that the angle it forms with another line is not a right-angle. A test question which covers all cases is: "If the junction dot were omitted, could the arrangement be interpreted as a crossing?" If it could, the arrangement is wrong.

Connecting lines may slope at any angle or even be curved, but a plethora of lines at various angles can look like a dog's dinner. Input and output terminals should be at the edges of a circuit, not buried inside it. In most circuits there is no need to insert an H.T. or G.B. "battery" or to join all the H.T. points together; in some explanatory circuits it may be advantageous to do so. There is no need to join wires to a common earth; there is a growing—and commendable—tendency to scatter separate earth symbols wherever this makes for clarity (e.g. in decoupling circuits); the process can, however, be overdone and may complicate rather than simplify the circuit.

The number of crossings in a circuit can often be reduced by rearrangement. Where several units are to be joined, the connections may sometimes be omitted, similarly lettered or annotated arrowheads being provided, usually at an edge of the circuit. Heater connections are nearly always omitted, arrowheads at the valves being lettered (e.g. x, x).

The drawing of a circuit in a way that makes it self-explanatory is often troublesome, but always rewarding. Some technicians boast that they really enjoy puzzling-out obscure circuits; one wonders whether they would make a salary-rise application in the form of an acoustic. If any reader feels all these conventions are a bind, he may console himself with the fact that they are equally binding on an F.R.S.

A final word on laboratory jargon: A vivid picture is conjured up by "the cathode sits at earth, the anode dropping till it bottoms". It is magnificent, but is it English?

APPENDIX

Some useful reference books are listed. The B.S. books are issued by British Standards Institution, 24 Victoria Street, London, S.W.1.

Standardisation of Technical Terms and Circuit Presentation*

By J. Scott-Taggart,† M.I.E.E., M.I.Mech.E., F.Inst.P.

This article is a condensed version of an article that appeared in the "Naval Radio and Electrical Review." The original spelling and method of writing abbreviations have been adhered to throughout, although in a number of cases these are different from the conventions normally adopted by this journal.

THE Fighting Services, the Post Office, the Ministry of Supply, numerous learned societies and others are insisting on adherence to certain standard technical terms, graphical symbols and methods of drawing circuits. Radio and electronic companies have shown far less interest in these matters, although Government departments having contractual relations with them are continually pressing them to observe the standards, to reduce or obviate the need to re-draw circuits and re-draft commercial handbooks. The following notes outline briefly some of the changes in conventions.

The chief authority is the British Standards Institution, but there are also inter-Services standards committees, while the Royal Society, Institute of Physics, I.E.E. and other institutions lay down rules which authors are compelled to obey. The substance of these various regulations—which only rarely conflict—is given below. Some of the decisions are not acceptable to everyone, but neither are all the laws by which we are governed.

Circuit symbols and unit abbreviations have been standardised but many technical terms are simply recommended as "preferred terms"; it is recognised that it is hard to change the phraseology of a lifetime. The trouble is that radio has long since shed its swaddling clothes, whereas many of its nurses are still alive; it is not surprising that much of the baby-talk survives.

The concrete nouns capacitor, resistor and inductor replace condenser, resistance and inductance. Feedback—once a vulgarism—is approved; the Services prefer frequency-meter to wavemeter, a wavelength meter being (oddly enough) reserved for measuring the length of stationary waves. The I.E.E. blithely accepts *outage* and *throughput* but scorns the useful word *circuitry*. Wattage is called jargon but is "acceptable"; when did voltage become respectable? Standards committees prefer balanced valve operation to push-pull. Transmitter blocker replaces A.T.R. switch and anti-T.R. box, although T.R. switch is retained. *Cat's whisker* is still blessed by the committees, as is *keep-alive electrode*. Grid leak is retained, although clearly grid resistor is better if negative bias is applied through it. No guidance is given on the choice between H or TE, E or TM applied to waveguide modes, although the Americans prefer TE and TM. Subscripts are standardised but the standard is not that preferred by Americans. Voltage standing wave ratio is minimum/maximum whereas in America it is the reciprocal; international agreement on standardisation is a long way off.

The word *mixer* refers to the non-linear device (e.g. a crystal mixer) used in a frequency-changing circuit (which is the mixer plus local oscillator). Monostable, bistable

and astable relaxation circuits are (unfortunately) to be called stable trigger circuit, flip-flop and multivibrator respectively; one-shot multivibrator is rightly deprecated.

Classification of frequencies remains rather chaotic. Superlatives have had a chequered career and terms like very-low, very-high, ultra-high, super-high and extremely-high frequency make one reach for the book to find out what they mean or whether they even exist. There are many electrical engineers still alive who called 50 cycles per second "high frequency" when 25 cycles was becoming obsolete. For the moment, the Services—as distinct from B.S.204—use millimetre, centimetre, decimetre, metre, short, medium and long waves.

Radiolocation is no longer the same as radar; it includes D.F. (direction-finding) as well as radar. Radar includes systems involving automatic re-transmission when the delay is short and precise enough for range to be measured.

Units are a common source of error. The letter m should be reserved for milli- and μ for micro-. Abbreviations like mf, mF or mfd should be replaced by μ F. The Greek letter μ is apparently regarded by many as "mathematics" and therefore "difficult". The most abused letter is probably k; one often sees 500 Kc/s or 15 KW instead of 500 kc/s and 15 kW; illogically, a capital K is to be used in circuit diagrams. Capacitances marked on diagrams should be in picofarads (pF) up to 999 pF; capacitances above this are marked in microfarads (μ F); thus 500 pF should be used, not .0005 μ F. Resistances up to 999 ohms are marked with the number followed by Ω . Resistances of 1 000 ohms and over (but below a million) use K Ω . Resistances of 1 megohm and over are represented by M Ω . A permissible abbreviation in circuits is to omit Ω and F; to omit μ is not allowed (you can use 25 μ F or 25 μ but not 25). In texts, a nought should be put in front of the decimal point (e.g. 0.05 μ F); whether this should apply to circuits has been argued. In circuits it is perhaps permissible to use, say, .05 μ but never .5 μ (use 0.5 μ); the test is whether the omission of the decimal point would lead to misunderstanding; the initial nought before a decimal point is not used in mechanical drawings.

In scientific papers it is now customary to omit the comma to indicate thousands, a small gap being left; this is to prevent the comma being read as a decimal point; the popular 50,000 becomes 50 000. The gap is not used in dates, patent numbers or page numbers. Abbreviations of units such as yd, in, db, lb, should not have a full-stop after them (unless punctuation requires it); if ambiguity is otherwise likely, "in" may have a full-stop after it. Plurals of contractions should have s preceded by an apostrophe, e.g. e.m.f.'s, but unit contractions should never have an s (cms, yds, lbs, ins, dbs are all wrong).

The plural of henry is henrys. The abbreviations & and &c should not be used, but etc. is permissible. Specific quantities should be denoted by figures, e.g. 5 in, 210 V,

* Condensed, with permission, from an article in "Naval Radio and Electrical Review."

† Admiralty Signal and Radar Establishment.

accuracy called for being considerable, since the cut strips are often as narrow as half an inch.

To attain the necessary positioning of the paper approaching the cutting knives a nominally continuous $\frac{1}{8}$ in. line is printed along its length, and at any instant a short length of line is illuminated and observed by a suitable

hundredweight are readily controlled by the small servomotor, owing to the low apparent static friction brought about by the haphazard vibration caused by the unrolling of the paper.

Acknowledgments

The writer would like to thank the following (all of

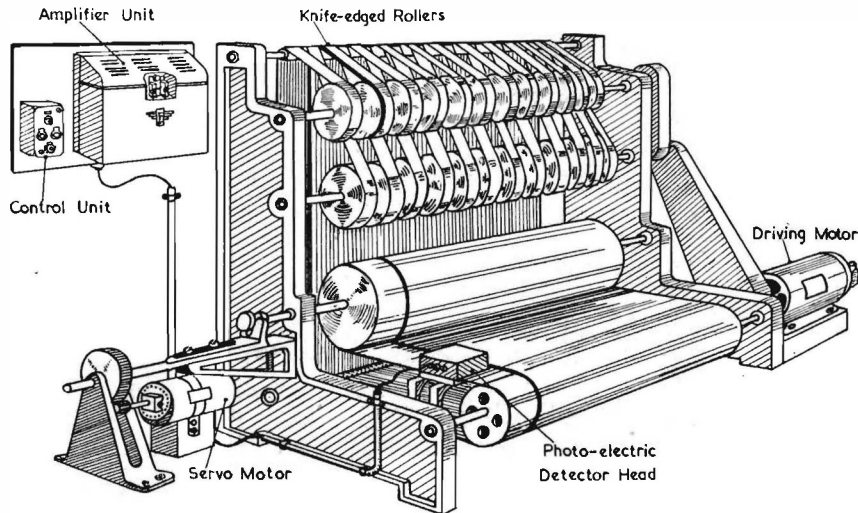

Fig. 12. Paper splitting machine

photoelectric detector head, which is capable of discriminating the direction of the positional error of the line from the desired position. Correction is obtained in this instance by the lateral movement of the whole roll of printed paper. It is interesting to note that rolls of paper of up to two

Ferranti Limited): J. Greenhalgh, B.Sc., for his fundamental work at the commencement of the project. J. L. Gray, B.Sc., for his assistance in the later stages, and Les. Allen, without whose persistent and untiring practical work the project would not have reached fruition so expeditely.

Speech Equipment at St. Paul's Cathedral

A new speech reinforcement system is being tested in St. Paul's Cathedral. This is a particularly difficult building for speech because of its very reverberant acoustics. The reverberation time is 12 seconds in the empty Cathedral compared with 4 seconds in the Royal Albert Hall empty or $2\frac{1}{4}$ seconds in the Royal Festival Hall empty. The new system makes use of two recent developments, the loudspeaker column and time delay.

The human voice, or the sound from an ordinary loudspeaker, spreads out more or less equally in all directions. This means that while some of the sound travels straight to the listener, most of it, in a very reverberant place such as the Cathedral, reaches him by reflexion from the various surfaces after a considerable time interval. If all, or nearly all, the sound could be directed towards the listener the reflected sound would be negligible. This is achieved by a loudspeaker column consisting of a number of ordinary loudspeakers placed in a vertical line. This arrangement, by an interference process, produces a beam of sound which spreads out equally in all directions in the horizontal plane, but which in the vertical plane is confined within a few feet.

In the Cathedral, one such column is at present placed next to the pulpit and the sound from it is directed towards the congregation in the dome area. There is a limit to the

distance that this one column will cover, and so additional columns are installed down the nave.

A listener at the east end of the nave may be about 20ft, say, from one of the loudspeaker columns in the nave and 120ft from the column next to the pulpit. With an ordinary amplification system the sound from the nave will reach him about $1/10$ th second before the sound from the pulpit. Since it is the sound which arrives first which mainly determines the apparent direction of the source (the Haas effect) the listener would think that all the sound was coming from the nave loudspeaker. If an electrical delay is introduced into the nave loudspeaker so that it is delayed by slightly over $1/10$ th second the sound from the pulpit loudspeaker will reach the listener first and he will now think that all the sound is coming from the pulpit, with an obvious gain in realism. This has been done in the Cathedral, and the illusion that all the sound is coming from the pulpit can be maintained over the whole congregation area. The necessary time delay is obtained by means of a magnetic recording and playback unit.

The new system has been designed by the Building Research Station in collaboration with Pamphonic Reproducers, Ltd., the Building Research Station work being under the direction of P. H. Parkin, B.Sc., A.M.I.E.E.

the amplifier, and were recorded on a constantly moving piece of paper. Two curves were taken when error signals were applied suddenly to the amplifier input within its linear range of operation, and two when the linear range was well exceeded. One of each group was with no inertia beyond that of the motor and gearbox, the others were taken when inertia, in the form of a flywheel, had been added such as to double the total inertia of the system. A two-thirds correction of input error has been designated the time-constant of the system, and the figures shown against each curve are obtained by measurement of the curves. Time of response is here defined as the time in which the error had been corrected to within approximately 10 per cent. In each case an endeavour was made to set the velocity feedback in such a manner as to give the system a single correcting overshoot.

Various other improvements have also been made by reducing the number of components and rearranging the circuit, so that a coupling neon is no longer required, (Fig. 11 shows the basic final circuit) chassis construction was simplified leaving component connexions more readily accessible, and the mounting frame was simplified. The maximum gain of the amplifier has also been increased and now averages 1750mA/V up to 85 per cent of maximum output, the input voltage for this being approximately

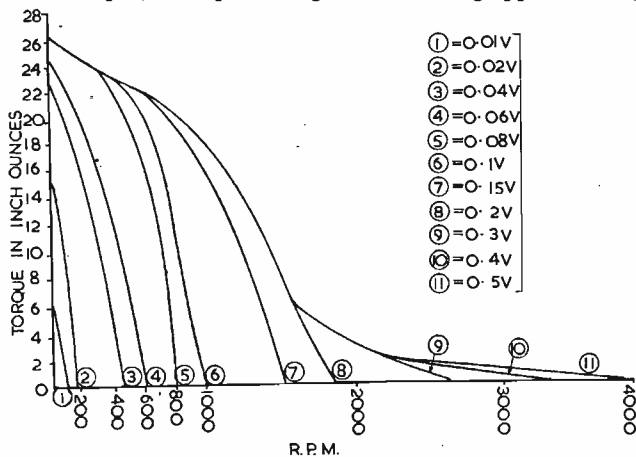

Fig. 9. Speed/torque curves (Mk II) Full feedback

$\pm 30\text{mV}$ about the balanced condition. The control box has also been developed by making it more robust and having the ability to have some of its controls used as pre-sets at will in a very simple manner. The reason for this latter move is that since it is unwise to give unskilled operatives too many controls to handle, it has been arranged to reduce the number of controls needed in the cloth guider application down to one—the cloth positional control which is really an attenuator arranged to give a small change in the balanced conditions of the amplifier.

The amplifier circuits are such that all variations required in the system are automatically taken into account when the cloth is correctly positioned.

This is possible since the change from an opaque to a transparent material alters the effective loop gain of the whole system, (i.e., a given movement of cloth in the edge detector causes a certain torque to be exercised by the motor), and the electrical attenuation is altered to maintain the operating conditions, also the change of material alters the relative position of the cloth-edge to the photocell for the same quantity of light falling on the cell, thereby necessitating a change in the balance conditions of the amplifier to allow for a different potential from the photocell as given by the changed cloth when in the required physical position.

Both these variations are directly dependent on the

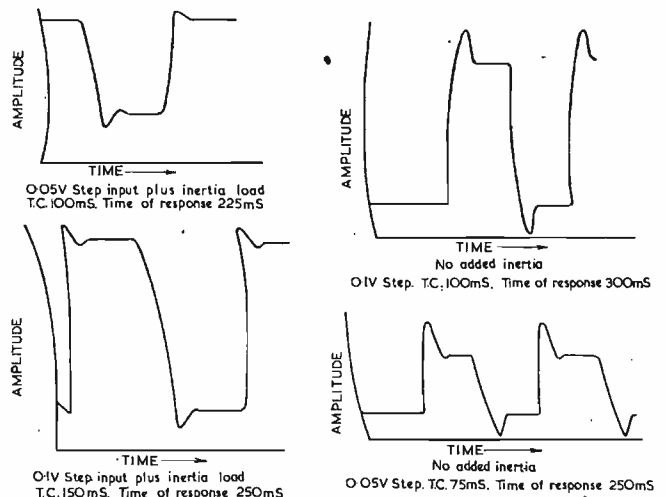

Fig. 10. Response curves of prototype (Mk II)

transparency of the cloth and may therefore be taken into account simultaneously with one control suitably connected into the circuit.

The stability control may be left in a pre-set condition over the range of cloth speeds normally met on any given machine, provided that the feedback voltage is injected into the circuit in a position unaffected by the electrical gain at which the amplifier is operating (this was not the case in the first model). The other pre-set control may be regarded as a master cloth positional control, occasional adjustment of which, by a technician, will take into account practically all of the variations of operation which may be caused by ageing of amplifier components, and similar long-term variants if they should occur. The overall reliability of this type of equipment, at least from the electronic aspect, is now of the order of twelve months.

The number of uses to which this packaged servomechanism could be applied is very great, but one example only will be quoted, and that is the controlling of the position of printed paper approaching the knives of a slitter, as illustrated in Fig. 12. Wrapping papers and the like are normally printed in broad rolls, being subsequently cut lengthwise, and then re-rolled. It is obviously desirable that the cutting should be correctly positioned relative to the printed matter (not shown on the drawing), the

Fig. 11. Simplified circuit of servopack

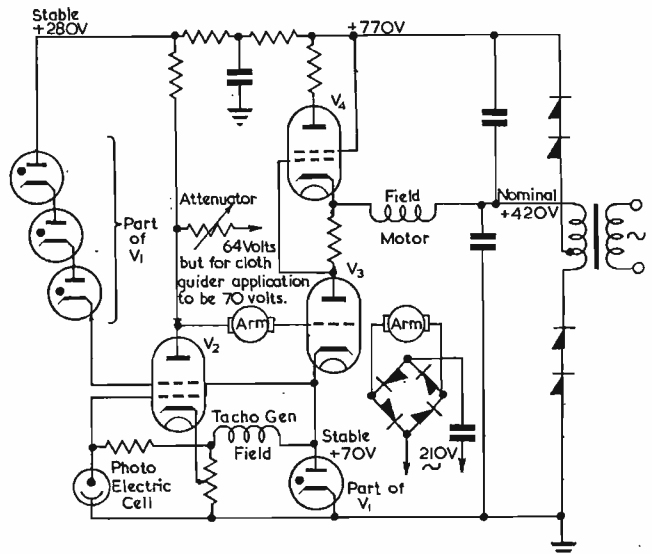

week, with occasional breaks of one hour or so for wash-down) by the introduction, where required, of stabilized resistors, stabilizing transformers, and stabilizing neons, whose long-term consistency of potential was high.

At the same time, however, a new amplifier was designed with the same performance characteristics as the original, but taking into account all the things that had been learnt from the first design, and not forgetting the possibility of need for servicing under the very unfavourable conditions frequently met in the textile industry, where it is not at all unusual to be standing in water, in a cloud of steam, or in a temperature of 120° F.

One of the greatest advances in the new amplifier design was the basic circuit simplification, with the reduction of the number of valves of all types to a total of four and a

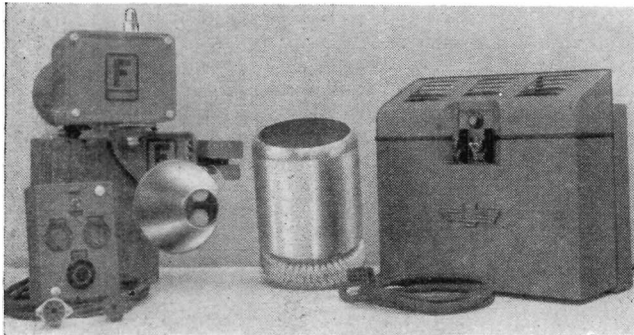
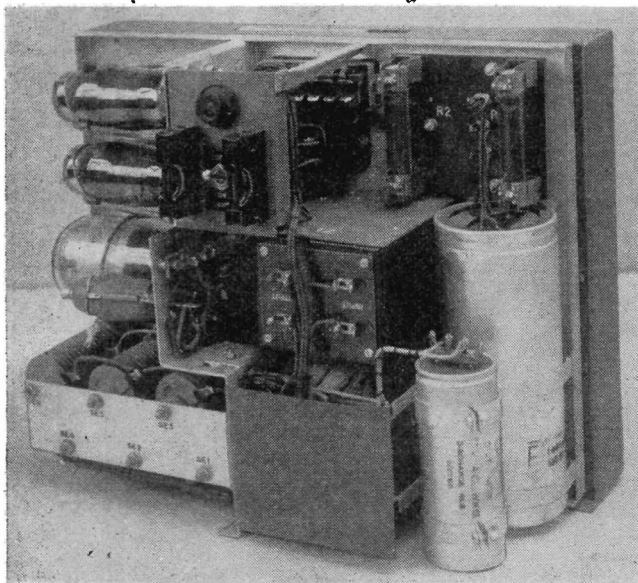

Fig. 6. Units of cloth guider (Mk II)

Fig. 7. Servo amplifier (Mk II)



coupling neon which was used between the one voltage amplifying stage and the output stage, thereby reducing very greatly the number of critical components. The components used were very carefully chosen for their reliability, ordinary radio components seldom being suitable. Other features included the automatic removal of the velocity feedback when large errors needed correcting, as may happen when there is a tear in the cloth, thus ensuring the greatest possible speed of response when outside the linear range of operation of the amplifier; the enclosing of all connexions to units, the leads being terminated in suitable plugs, so that interchange of units could be undertaken by relatively unskilled personnel, and the equipment was also "packaged" into units for flexibility in the anticipated event

of the amplifier being utilized for applications other than guiding cloth.

Fig. 6 shows the various units of the new design. The amplifier is released rapidly by raising a lever on top of the mounting frame, drawing the amplifier forward to a stop, then lifting upwards and off, all connexions are broken automatically. A fresh amplifier may then replace the one removed if necessary. Other connexions are made with the aid of plugs and sockets inside the motor unit, which is detachable from the gearbox. Fig. 7 shows the cover off the amplifier unit, and also gives an idea of the size and relative compactness of this unit, all component connexions being accessible from the front when the switch panel is pivoted upwards. Immediately the amplifier is removed from its mounting frame, or the cover removed, interlocking switches remove power from the unit, but in the event of a technician artificially operating the interlock switches in order that he may make electrical tests in situ, lifting the switch panel will cause the pilot light to illuminate the interior of the amplifier, this being of great assistance in dark corners of mills and the like.

One trouble with the prototype of the new amplifier was the dissipation of the heat produced in it, a large proportion of which occurred through the necessity of endeavour-

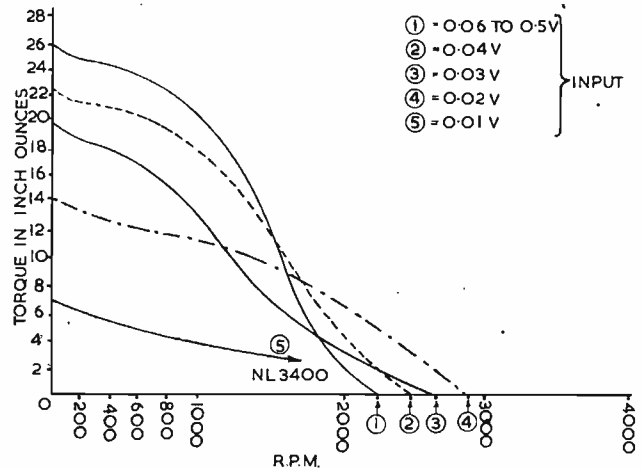

Fig. 8. Speed/torque curves (Mk II)
(No feedback)

ing to maintain a sensibly constant current through the armature of the motor unit in spite of back E.M.F. To this end some hundreds of volts D.C. were fed to the armature through limiting resistors, only about one-fifth to one-quarter of the total voltage appearing across the armature when it was stationary, some 40 watts being dissipated in the dropping resistors.

In later production models some 200 volts A.C. is fed through a capacitor to a bridge rectifier connected across the armature, as a result of which quite a large back E.M.F. may be produced by the motor before the armature current is appreciably affected owing to the control of this in quadrature by the capacitor. Not only does this save the 40 watts of waste heat, but it also gives rise to a different family of speed/torque curves, as shown in Fig. 8 where it will be noticed that the maximum power available from the motor shaft is at about 1,100 R.P.M. with a torque of about 18 inch ounces (this is over 7,000 inch pounds per minute of work), over three times the maximum power previously available as shown on the earlier family of speed/torque curves. The curves in Fig. 8 are taken with the amplifier at maximum gain and with no velocity feedback. Fig. 9 shows speed/torque curves with full velocity feedback.

Fig. 10 shows a series of curves for the prototype of the new design from which speed of response of the system can be ascertained. They were drawn by the movement of an arm connected to a cloth guider gear box coupled to

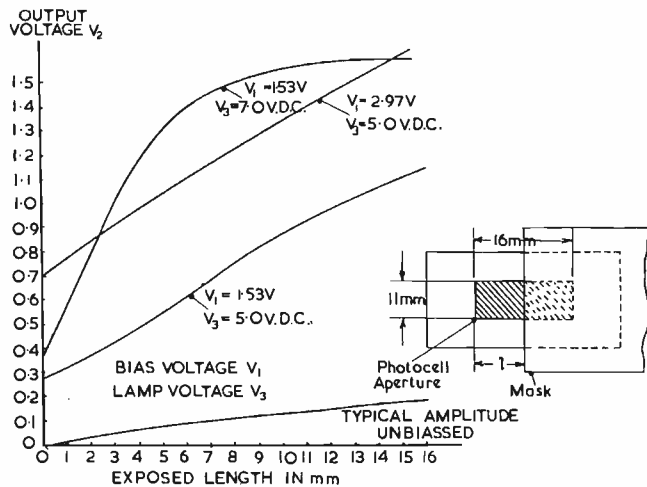
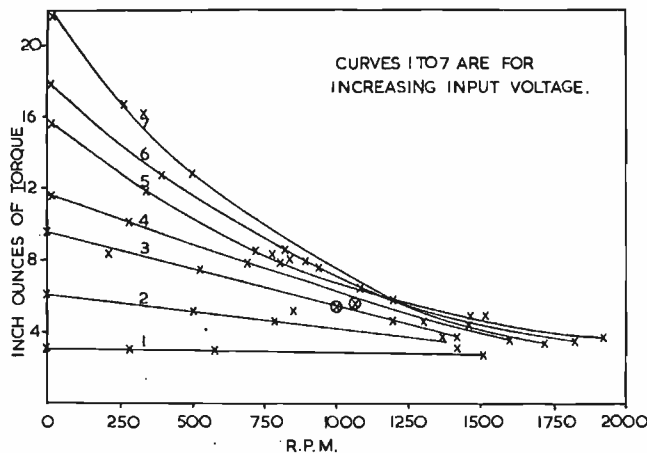

Fig. 3. Photocell sensitivity curves

the guider arm, indicated a gear ratio of about 20-1. A compromise of 16-1 was adopted.

In order to give information as to the position of the selvage relative to the guider arm, it was decided that a photoelectric cell should be utilized, which, when followed by a suitable amplifier, should be able to control the torque applied to the guider arm in accordance with the observed selvage positional error. If there were no error present, no torque was called for, and this meant that the amplifier must be capable of a zero frequency response, and a straightforward d.c. amplifier was decided on. This decision also made it advisable to get the greatest possible sensitivity in the photocell in terms of voltage change available for a given movement of cloth selvage. Fig. 3 shows diagrammatically how the cloth selvage masked some portion of the photocell, and the curves show the potential changes which were obtained under various conditions of masking and illumination, with a considerable increase of sensitivity obtained by biasing back the photocell, (which is of the selenium barrier layer type) the resultant gain being of the order of 5-1. The selenium type of cell was chosen on account of its robustness and small physical size when compared with a vacuum or gas-filled type. It also has a relatively low impedance, which means that the screening of leads is not always necessary. A d.c.

Fig. 4. Speed/torque curves (Mk I)



amplifier complete with some voltage stabilizing circuits was built. It also incorporated a cloth positional control and variable gain and velocity feedback or stability controls. (The velocity feedback or first derivative error was obtained from a small tachometer generator built in with the motor used on the guider head). These controls are necessary since, functionally, it is essential that the loop gain and the stability of the whole system should be sensibly constant, and the variants for which compensation must be made, are the opacity of the cloth, and the rate of the cloth approach.

As a result of all this a fairly complicated circuit evolved which included 18 valves of one sort or another and dissipated some 250 watts for each guider head, but this initial design proved experimentally that cloth could, in fact, be guided accurately, utilizing electronic control.

Fig. 4 shows the type of speed/torque curves of the output motor for changes of input potential to the amplifier, the output torque being sensibly linear relative to the input signal in the motor stalled condition up to about 20 inch/ounces. Maximum power was approximately 8 inch/ounce torque at 800 R.P.M. Although the point was proved, there were a large number of snags to be overcome, for the reliability of the equipment was of the order of 24 hours, due, as was gradually discovered, to such things as drift in the value of components, which, if in a d.c. potential

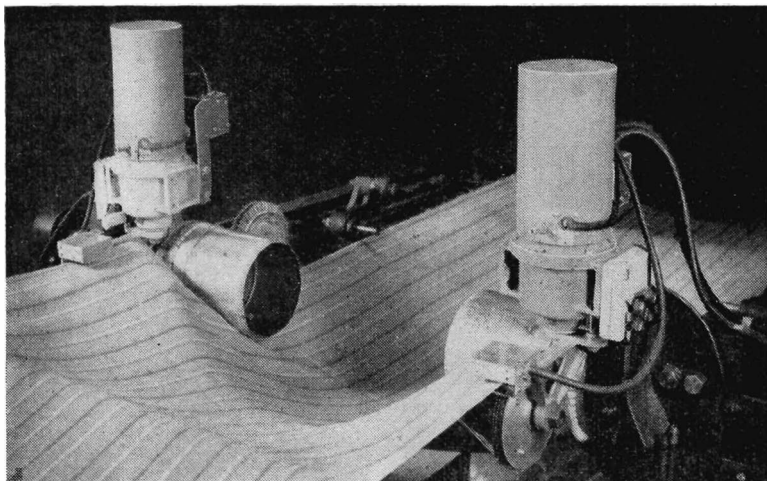

Fig. 5. Cloth guider heads (Mk I)

dividing chain, would very soon put the circuits out of their correct operating condition; the neon stabilizers used would vary their potential slightly from day to day which would also upset the fine balance of the d.c. coupled circuits. Also, in use by normal textile operatives, it was very unlikely that one found the various controls to be at their optimum setting, and protruding knobs, plugs, hanging cables, etc., frequently fell victim to heavy clogs, cable ends would fray, and a multitude of other minor troubles would develop. In addition, initial factory setting-up was a complicated affair of selecting resistors. Fig. 5 shows the first experimental installation, although many of the later detail improvements are included in this photograph, the design of the photocell detector head, for example, having been changed eight or nine times before finding the most satisfactory model. Incidentally this detector is so arranged that the edge of the cloth cuts the illumination to the photocell twice, giving rise to less variation in sensitivity over the operational range of cloth transparencies, and the output is rendered non-linear in either direction from the central position for a more lively response.

Slowly the reliability of the equipment was increased to the order of many months of continuous service (continuous means three shifts per day six or seven days per

An Industrial Servo-Mechanism

By P. H. Briggs,* B.Sc.

THIS is the history of the development of one particular servo-mechanism designed as the result of a specific industrial requirement.

In the textile industry it is necessary at one stage of processing the cloth, to feed it into a drying machine in such a manner that the selvages are accurately positioned on to a moving chain of pins. The manner in which the cloth approaches the machine is quite haphazard as far as lateral position is concerned.

In its approach the cloth may vary in width, as well as moving its lateral position and originally the only way to get reasonably accurate impalement was to have a man, or woman, sitting on each side of the approaching cloth and guiding it manually into its required position. Needless to say, the resulting accuracy left much to be desired.

As an advancement on this method, mechanical fingers were arranged to feel the selvage of the approaching cloth, and some power operated machinery then moved laterally each edge of the framework carrying the pin chain. This involves the movement of a considerable mass of machinery, and, as a result, needed quite a powerful

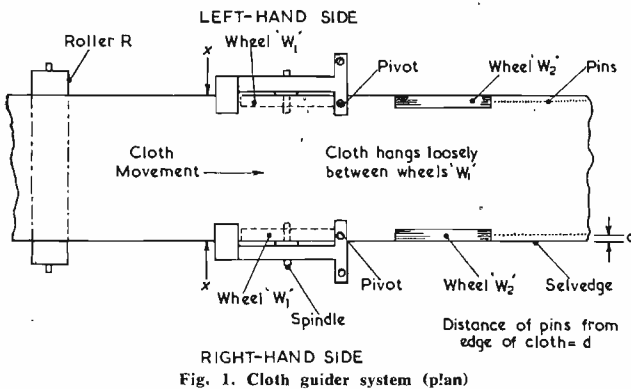

Fig. 1. Cloth guider system (plan)

electric, hydraulic or pneumatic mechanism to effect the movement, also there was generally an appreciable time-lag in positioning the entry frame relative to the incoming cloth, this sluggishness therefore did not give a high degree of accuracy of impalement. If the power to move the entry rails was increased too much, in an endeavour to reduce the sluggishness, the whole system was liable to oscillate.

In order to avoid some of the difficulties of cloth guiding, a new scheme was devised which avoided the necessity of moving large masses of equipment. Fig. 1 shows in a diagrammatic form the principle on which this new method of guiding functions. The cloth is approaching and passing over Roller R, and each selvage passes on to the periphery of wheels W_1 (the cloth between the wheels hangs loosely and is of no importance for the moment). The selvage next passes under wheels W_2 which presses the selvage on to the pins. If there were any lateral movement of the selvage on roller R, this would normally be passed on as a similar error in pinning. To prevent this, the bracket which carries the bearings of wheel W_1 is made to pivot about a vertical axis, the extension of which is tangential to W_1 , as shown in Fig. 2. The point P where the cloth leaves W_1 and is taken up by W_2 is a fixed point relative to the machine as a whole, irrespective of the angle of the bracket relative to the pin chain and, therefore, pro-

vided that the bracket is always turned so as to receive the selvage in a definite relative position, the cloth will always be fed off at a fixed point, hence giving the required guiding action, W_2 being a transfer wheel.

Owing to the small mass of the guider wheel and arm, a considerable speed of response, and therefore accuracy of guiding, should be attainable without the expenditure of much power. But once again, the position of the approaching selvage must be determined accurately, and this was again attempted by means of a delicately positioned mechanical feeler, which, if displaced, operated a micro-switch which in its turn caused air pressure to be applied to an air motor, thus causing a rotation of the guider arm.

This, however, was still a discontinuous action, no matter how the sensitive feelers were adjusted, for irrespective of the magnitude of the positional error of the cloth selvage, a definite force was exerted by the air motor upon the guider arm, and the air pressure had to be set very critically for any particular rate of movement of cloth in order that hunting, or oscillation, should not occur, or conversely in order that the system should not be too sluggish. Any particles in the air control valve or changes in the friction

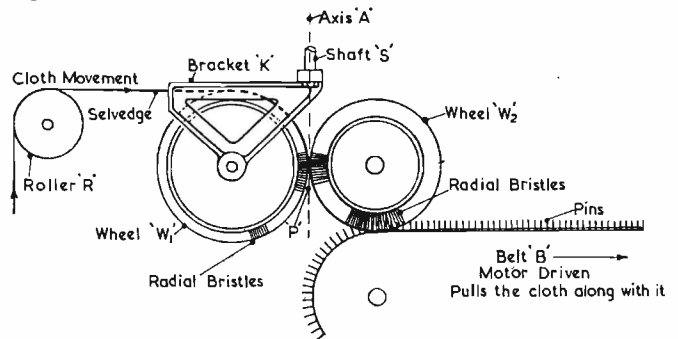

Fig. 2. Cloth guider system (side elevation)

of the system, would readily upset the rather fine balance of the equipment which was liable to misbehave.

It was therefore decided at the end of 1945 that an electronic approach to the problem should be taken, one of the main reasons being that it should be possible for the correcting torque applied to the guiding arm to be made proportional to the magnitude of the positional error of the cloth selvage.

A motor unit which lends itself to the operation of the guider arm, is one in which a constant armature current is passed, and which on the passage of current through its field system, will exert torque proportional to this current. Normally this motor is made with a split field winding, and currents are passed through the two halves in opposition, their difference giving rise to the output torque.

In order to obtain optimum performance it is of course necessary to interpose a suitable gear box between the motor and the guider arm shaft, which necessitates consideration of maximum speed of response, and guider arm torque requirements. For the first consideration, the inertia of the guider wheel and arm should reflect through the gearing a moment of inertia at the motor shaft equal to the moment of inertia of the motor armature and shaft itself. This would have necessitated a gear ratio of the order of 10-1. Considerations of torque such that the weight of the cloth would not cause unwanted rotation of

* Formerly Ferranti Ltd.

since V_4 has no means of screen and cathode voltage adjustment).

By virtue of the closed loop, θ_0 is constant, θ_1 is zero and θ_2 is also zero when the clamp releases. If θ_1 were at a level other than zero at this instant, θ_2 would immediately respond. The integrators would integrate this response and since the clamp releases before the step input is applied, the system would no longer be quiescent at the instant of impulsing. It therefore follows that, unlike closed loop systems, for open loop systems a step input is required which starts from zero and rises to a positive level.

If the integrators overload during the open loop or are used just short of overloading as described it may happen that valve V_4 will overload during the flyback, especially if the closed loop is underdamped. However, if the ω_0 of the closed loop is high enough, considerable overloading of V_4 can be tolerated without the quiescent state of the simulator being affected.

Figs. 17, 18 and 19 show oscillograms of open loop transfer functions corresponding to $(1/\rho T)$, $(1 + 1/\rho T)$ and $(1/\rho^2 T_2 T_4)$ respectively. Fig. 19 also shows overloading of the last integrator.

Conclusion

In this paper it has been described how simple second or third order transfer functions may be simulated. Higher order transfer functions which may or may not correspond to any physical servo-mechanism may be simulated by increasing the number of units, by using the error detector and phase inverter as function units or by connecting passive three terminal networks across the cathode-follower outputs of any of the units. The units may even be adapted to simulate certain non-linear systems. In all cases where stabilization is possible by a feedback circuit between any two units, unstable systems may be represented on a C.R.O. by intelligent use of the clamp.

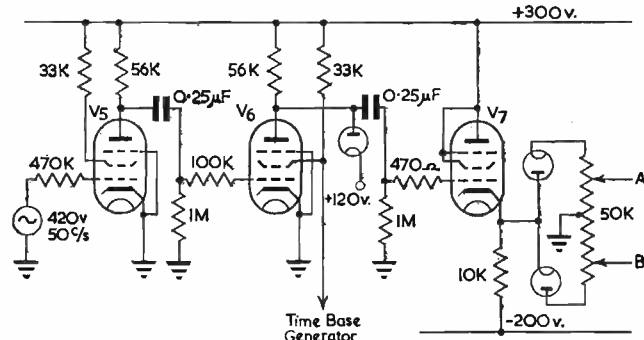

Fig. 20. Square wave generator

Acknowledgments

The work described in this paper was done in the Electrical Engineering Department of the Manchester University and the author is indebted to Professor F. C. Williams and members of his staff for assistance given and facilities enjoyed.

The author is also indebted to the South African Council for Scientific and Industrial Research who sponsored his visit to the University of Manchester and with whose permission this paper is published.

APPENDICES

1. THE SQUARE WAVE GENERATOR

The circuit arrangement is shown in Fig. 20. V_5 and V_6 are two "squaring" stages followed by a cathode follower

V_7 . A square wave output of variable amplitude is desirable. The step function for closed loop systems (i.e., an impulse rising from a negative level to earth) is taken from B and the step for open loop systems (i.e., an impulse rising from earth to a positive level) is taken from A. The waveform to drive the time-base generator is taken from the screen of V_6 and its amplitude should be unaffected by waveform variations in other parts of the circuit.

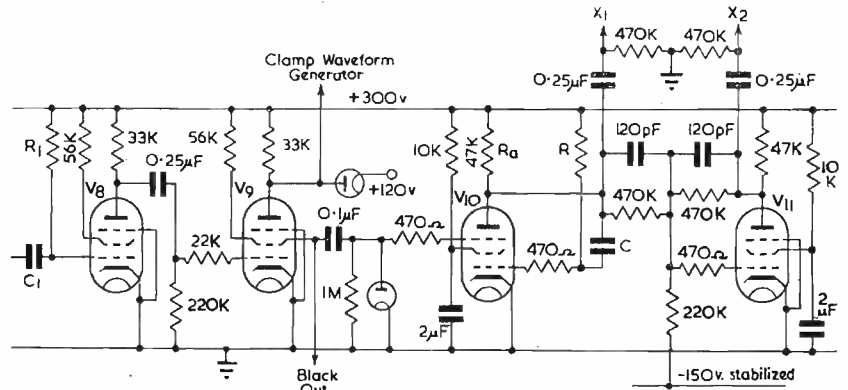

Fig. 21. The time-base generator

2. THE TIME-BASE GENERATOR

The time-base generator circuit is shown in Fig. 21. In order to view the instant of impulse better on a C.R.O. and to make sure that the system is quiescent when the step input is applied, it is desirable to have a synchronous time-base which starts earlier than the step function: the timing is arranged by means of V_8 and is a function of C_1 , R_1 and the amplitude of the controlling waveform from V_6 (Fig. 20). V_9 is a "squaring" stage which supplies the controlling wave for the clamp waveform generator and the C.R.O. black-out wave. V_{10} is a "Miller integrator", the run down of which is controlled on the suppressor grid by the black-out waveform. The time-base waveform is a function of C , R and R_a , which are varied to accommodate the C.R.O. V_{11} see-saws the output from V_{10} in order to utilize both X plates of the C.R.O.

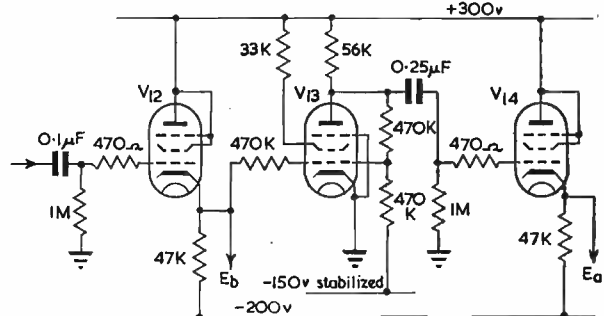

Fig. 22. "Clamp" waveform generator

3. THE CLAMP WAVEFORM GENERATOR

The waveforms for operating the clamp are derived from the anode waveform of V_6 in Fig. 21. The circuit arrangement is shown in Fig. 22: V_{12} and V_{14} are cathode-followers for driving the clamp and V_{13} paraphrases the waveform of V_{12} . E_a and E_b are the waveforms corresponding to those in Fig. 14.

REFERENCES

- WILLIAMS, F. C. : Introduction to Circuit Techniques for Radiolocation. *J.I.E.E.*, 93, P. III. A., 289 (1946).
- WILLIAMS, RITSON and KILBURN : Automatic Strokes and Recurrence Frequency Selectors, *J.I.E.E.*, 93, P. III. A., 1,188 (1946).
- WILLIAMS and RITSON : Electronic Servo Simulators, *J.I.E.E.*, 94, P. II. A., 112 (1947).
- BODE, H. W. : Network Analysis and Feedback Amplifier Design. (D. van Nostrand Co. Inc. 1945).

Open Loop Systems

Open loop systems containing integrators are fundamentally unstable for a maintained input. For example, if the integrators were to simulate a motor, this motor would accelerate for as long as the input signal is maintained and θ_o would tend to infinity.

For viewing the response of open loop systems on a C.R.O., the loop is arranged to be open during the time-base, but closed with appropriate ω_o and damping to make it quiescent during the flyback. This requires that both θ_o and θ_v be passed through the clamp before being fed back into the simulator. The method used is best explained by a simple example in which the open loop contains two pure integrators only. The circuit arrangement is shown in Fig. 16.

The feedback circuit is a simple error detector unit with a low impedance output. Since a phase reversal takes place in this circuit, either another phase reversal must be arranged before adding the feedback voltage to the error detector, or the feedback voltage may be added to the function unit. The latter method is more convenient, but in more elaborate systems it may be necessary to use the former, since some limit is set to the flexibility of the function unit. The relevant resistances are numbered.

THE OPEN LOOP

During the forward stroke of the time-base, the clamp is inoperative and assuming that the system is quiescent when the step input is applied

$$\theta_v = -R_2/R_1 \cdot 1/\rho T_3 \theta_i \text{ and } \theta_o = 1/\rho T_4 \theta_v$$

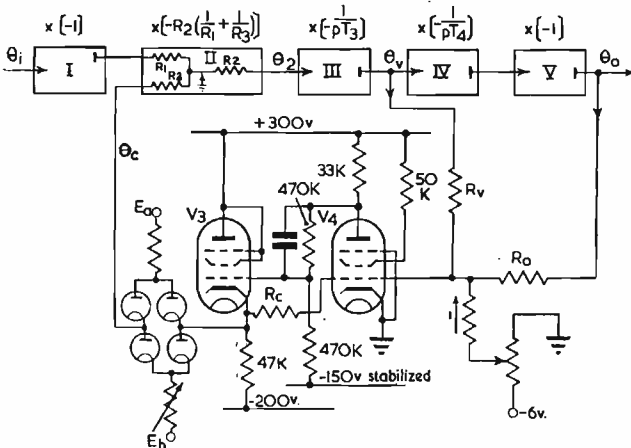

Fig. 16. The clamp as applied to open loop systems

For a step function input

$$\theta_v = -\theta_i R_2/R_1 \cdot t/T_3 + \theta_v^1$$

and

$$\theta_o = -\theta_i \cdot R_2/R_1 \cdot 1/T_3 T_4 \cdot t^2/2 + \theta_v^1 t + \theta_o^1$$

where θ_v^1 and θ_o^1 are the voltage levels of the two integrators respectively immediately before the input is applied. However, since at this instant (i.e., at $t = 0$) the system is quiescent (i.e., θ_o is constant), $\theta_v = \theta_v^1 = 0$ and $\theta_o = \theta_o^1$. The first integrator and all the preceding units must therefore always start from zero, while the last integrator may start from any quiescent level θ_o^1 . If no overloading is to take place in the valves, the maximum step that can be applied is 60 volts and the maximum excursions of θ_v and θ_o by the end of the step (i.e., after .01sec) 60 volts and 120 volts (-60V to +60V say) respectively.

For $T_3 = T_4 = 400\mu\text{S}$ (as in the previous sections) when $t = .01\text{sec}$.

$$\theta_v = -25\theta_i$$

$$\text{and } \theta_o = -31.25\theta_i + \theta_o^1.$$

Therefore for no overloading to occur $\theta_i < 60/25 = 2.4$ volts. This is undesirable, since for reasonable traces on the

C.R.O. all waveforms should be comparable. If θ_i were increased, on the other hand, overloading conditions are reached too soon in the integrators.

In the extreme case where the maximum excursions of all the units are utilized, it is required that at $t = .01\text{sec}$, $\theta_v = -\theta_i$ and $\theta_o = 2\theta_i + \theta_o^1$: for this, $T_3 = .01\text{sec}$ and $T_4 = .0025\text{sec}$. Compared with closed loop systems, T_3 and T_4 are thus much larger. In fact, if the above open loop were closed in the manner previously described, then $\omega_o = 200$ radians/sec and $f_o = 32\text{c/s}$ and there would not be time to damp it during the flyback. Thus means are required to increase ω_o to at least 1,000rad/sec, say, (i.e., $f_o \approx 160\text{c/s}$); fortunately this can be done by incorporating some gain in the feedback loop, through the clamp, as indicated below.

THE CLOSED LOOP

For the circuit of Fig. 16:

$$\theta_o = -R_c(\theta_o/R_o + \theta_v/R_v + i)$$

(Since the grid of valve V_4 is a "virtual earth", i is a sensibly steady current, the effect of which is to add a step voltage, $-iR_c$, to the function unit when the clamp is suddenly closed).

$$\theta_v = R_2/R_1 \theta_i - R_2/R_3 \theta_o, \theta_v = -\frac{1}{\rho T_3} \theta_v \text{ and } \theta_o = \frac{1}{\rho T_4} \theta_v$$

From the above equations

$$(-\theta_o)(\rho^2 T_3 T_4 R_3/R_2 \cdot R_o/R_c + \rho T_4 R_o/R_v + 1) = R_3/R_1 \cdot R_o/R_c \cdot \theta_i + iR_o$$

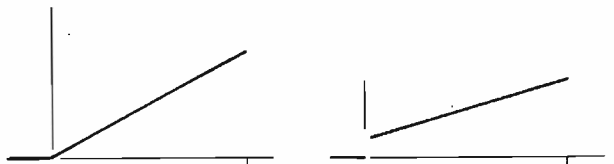

Fig. 17. Open loop transfer function of $1/\rho T$

Fig. 18. Open loop transfer function of $(1 + 1/\rho T)$

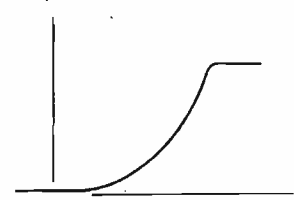

Fig. 19. Open loop transfer function of $(1/\rho^2 T_3 T_4)$ with overloading of the last integrator

Neglecting the phase reversal of θ_o

$$\theta_o(\rho^2/\omega_o^2 + \rho T + 1) = \theta_i^1$$

where θ_i^1 is the equivalent step input due to the combined effects of θ_i and i ; $1/\omega_o^2 = R_3 R_2 \cdot R_o/R_c \cdot T_3 T_4$ and $T = R_c/R_v T_4$

For $T_3 = .01\text{sec}$ and $T_4 = .0025\text{sec}$ and for $\omega_o = 1,000\text{rad/sec}$

$$R_2/R_3 \cdot R_c/R_o = 25$$

Making $R_1 = R_2 = R_c = 1$ megohm, then $R_o = R_3 = 200$ kilohms.

For critical damping $\omega_o T = 2$, i.e., $R_v/R_o = 1.25$, i.e., $R_v = 250$ kilohms.

In the quiescent state:

$$\theta_o = \theta_i^1 = R_3/R_1 \cdot R_o/R_c \theta_i + iR_o = \theta_o^1$$

Therefore:

$$\theta_o^1 = .04\theta_i + 10^6 i$$

By the suitably adjusting i the last integrator can be brought to any quiescent level irrespective of θ_i . In fact, for $\theta_o^1 = -60$ volts, the effect of θ_i (also 60 volts) is negligible and a current i of 60 micro-amps is required (that is, 60 micro-amps in addition to the current that is already required for making $\theta_c = 0$ for zero input to V_4 ,

However, this system is unstable and can only be viewed on a C.R.O. with the aid of the clamping arrangement to be discussed later on. Three easy methods of stabilizing this system are:

(a) VISCOUS FRICTION :

$$G = \frac{1}{\rho T_3} \cdot \frac{1}{\rho T_3 + R_3/R_3^1} \text{ and } A = \frac{1}{\rho^2 T_3 T_4 + \rho R_3/R_3^1 T_4 + 1} = \frac{1}{\rho^2/\omega_0^2 + \rho T + 1}$$

(where $1/\omega_0^2 = T_3 T_4$ and $T = R_3/R_3^1 T_4$).

For critical clamping $\omega_0 T = 2$ and if $T_3 = T_4 = 400 \mu\text{S}$, $R_3/R_3^1 = 2$.

This response is shown in Fig. 12.

(b) PHASE ADVANCE :

$$G = \frac{1 + \rho T_2}{1 + \rho T_2^1} \cdot \frac{1}{\rho^2 T_3 T_4} \text{ and } A = \frac{1 + \rho T_2}{\rho^3 T_3 T_4 T_2^1 + \rho^2 T_3 T_4 + \rho T_2 + 1} = \frac{1 + \rho T_2}{\frac{\rho^3 T_2^1}{\omega_0^2} + \frac{\rho^2}{\omega_0^2} + \rho T_2 + 1}$$

For pure derivative control and critical damping $T_2^1 = 0$ and $T_2 = 800 \mu\text{S}$.

(c) VELOCITY FEED BACK :

Let a fraction K_v of θ_v be fed back to the error detector. (K_v is adjusted by varying the input resistance from θ_v to the error detector).

$$\theta_0 = \frac{1}{\rho^2 T_3 T_4} (\theta_i - \theta_0 - K_v \theta_v) = \frac{1}{\rho^2 T_3 T_4} (\theta_i - \theta_0 - \rho T_4 K_v \theta_0)$$

$$G = \frac{1}{\rho^2 T_3 T_4 + \rho K_v T_4} \text{ and } A = \frac{1}{\rho^2 T_3 T_4 + \rho K_v T_4 + 1} = \frac{1}{\rho^2/\omega_0^2 + \rho T + 1}$$

For critical damping when $T_3 = T_4$, $K_v = 2$.

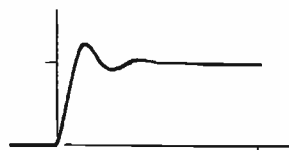

Fig. 13. Second order closed loop system 1/2 critically damped by "velocity feedback"

The output response for a step function input when $K_v = 1$ (half critical damping) is shown in Fig. 13. This corresponds to the equation:

$$\theta_0 = \theta_i \left[1 - \sqrt{2} e^{-\omega_0 t/2} \sin \left(\frac{\omega_0 t}{\sqrt{2}} + \tan^{-1} \sqrt{2} \right) \right] + \theta_0^1$$

Consider velocity feedback with an otherwise unstable system. If the function unit simulates a simple lag

$$G = \frac{1}{1 + \rho T_2^1} \cdot \frac{1}{\rho^2 T_3 T_4}$$

With velocity feedback $G = \frac{1}{\rho^2 T_3 T_4 (1 + \rho T_2^1) + \rho K_v T_4}$

and $A = \frac{1}{\frac{\rho^3 T_2^1}{\omega_0^2} + \frac{\rho^2}{\omega_0^2} + \rho T + 1}$ where

$$1/\omega_0^2 = T_3 T_4 \text{ and } T = K_v T_4$$

Whether this system is stable or unstable depends on the relative values of ω_0 , T^1 and T , but in general R.P.C. systems can be stabilized by velocity feedback.

If systems which are still in a transient state by the end

of the step input are to be viewed on a C.R.O., these may be brought to a quiescent state by applying the appropriate velocity feedback during the flyback of the time-base, provided that $1/\omega_0$ is small enough in comparison with the duration of the flyback. This is done by a clamping arrangement which will now be described.

The Clamp

With the addition of the clamp the circuit diagram of the simulator becomes as shown in Fig. 14.

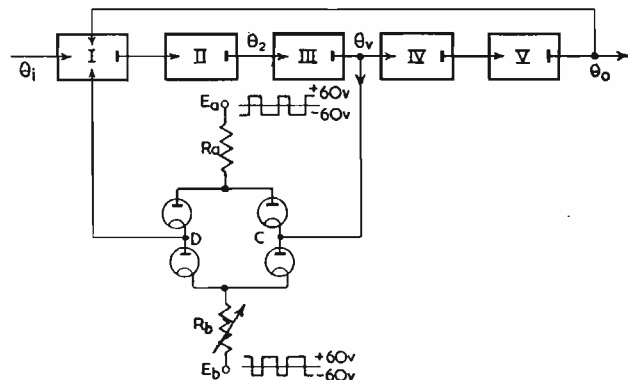

Fig. 14. The clamp as applied to closed loop systems

The voltages E_a and E_b applied to the clamp are +60V and -60V respectively during the flyback and -60V and +60V during the time-base, (i.e., E_b is the exact antiparaphase of E_a). If the diodes are similar and $R_a = R_b$, all four diodes are conducting during the flyback and point D will be clamped to point C by a low impedance. By ensuring that the output impedance of the first integrator is low compared with the impedance of the clamp, the voltage at D will vary as θ_v and θ_v will be unaffected. Any required amount of velocity feedback can be applied to the error detector in order to make the system quiescent. During the forward stroke of the time-base the diodes are non-conducting and point D will be floating.

Releasing the clamp must not introduce an error signal, for if it did a transient would be generated before the proper stimulus arrived. To ensure this, units I and IV must have accurately set zeros: that is, with a clamped closed loop and no stimulus, the grid potential of the V_1 of unit I and cathode potential of the V_2 of unit III must be made zero by appropriate screen voltage adjustment in units I and IV. This is, of course, the proper operating condition of all the units, but is less essential when the clamp is not used. Even when this has been done slight assymetry in the clamp operating waveforms may produce a small transient at the beginning of the time-base: this can be eliminated by adjustment of R_b . The waveforms

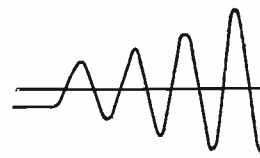

Fig. 15. Unstable closed loop system

for operating the clamp are derived as explained in Appendix 3.

With the clamp in position, the servos previously described can be examined under unstable and very lightly damped conditions, as can many other configurations leading to instability. Criteria for stability can therefore be determined or checked.

The oscillogram of an unstable response is shown in Fig. 15.

For this circuit

$$e_o \frac{1 + \rho CR_2}{R_2} = -e_i/R_1$$

or

$$e_o = -R_2/R_1 \cdot \frac{1}{1 + \rho CR_2}$$

which has the same form as Equation (2) above.

The Function Unit

The function of this unit is to operate on the error signal by a desired transfer function before feeding it to the integrators. It may be used to represent active or passive networks usually associated with servo-mechanisms for the purpose of stabilization or error correction. A wide variety of transfer functions is possible even with only one unit. In Table 1 it is shown how a few of the more common transfer functions may be simulated.²

TABLE I

	PASSIVE NETWORKS	FUNCTION UNIT
1. Phase Advance		$\frac{e_o}{e_i} = \alpha \frac{1+pT_1}{1+pT_2}$ $T_1 = C_1 R_1, T_2 = C_2 R_2$
2. Error plus Derivative of Error		$\frac{e_o}{e_i} = -\frac{R_2}{R_1} (1+pT_1)$ $T_1 = C_1 R_1$
3. Smoothing or phase lag		$\frac{e_o}{e_i} = \frac{1}{1+pT_2}$ $T_2 = C_2 R_2$
4. Integral Control		$\frac{e_o}{e_i} = -\frac{R_2}{R_1} \frac{(1+pT_1)}{(1+pT_2)}$ $T_1 = C_1 R_1, T_2 = C_2 R_2$
5. Error plus Integral of Error		$\frac{e_o}{e_i} = \frac{R_2}{R_1} \left(1 + \frac{1}{pT_2}\right)$ $T_2 = C_2 R_2$

In order to have the input and output waveforms of the function unit comparable, R_2 is usually made equal to R_1 . Thus, in case (1) $\alpha = C_2/C_1$.

The similarity of simulation of the first four transfer functions becomes at once apparent. However, in phase advance or derivative control we have $T_1 > T_2$, while in smoothing or integral control $T_2 > T_1$. Phase advance reduces transient or high frequency errors and will tend to stabilize an otherwise unstable system. Integral control or smoothing reduces steady state or low frequency errors and will tend to make a system "more unstable".

In practical function unit circuits care must be taken that the grid of the valve is not at times "floating" due to series capacitance elements. In such cases the grid must be tied to earth with a relatively high resistance. When phase advance, or in particular derivatives of error circuits, are used, the valve must not be overloaded due to the derivative component of the input signal.

The phase inverter unit is a standard unit as in Fig. 7 but with $Z_o = Z_i = R$.

The remaining item to be described is the clamp; however, since it is possible to study adequately damped systems without it, it is convenient to digress at this point to discuss the simulation of such systems.

The Simulation of Various Stable Systems

Whereas the signals in real servo-mechanisms usually have different dimensions, the simulator signals are all voltagcs. It is convenient, in the following discussion, to think in terms of a R.P.C. servo-mechanism, where θ_i is

a step input position demand and θ_o the output position response. In such systems, if there is to be no steady state error of position, the loop must contain at least one pure integrating transfer function (the last integrator).

For convenience the suffixes 1 to 5 refer to the corresponding units. The steady state or d.c. gain between θ_i and θ_o is in each case arranged to be unity and in the mathematical discussions the phase reversal between θ_o and θ_i is neglected.

In a closed loop system, the closed loop gain $A = \theta_o/\theta_i$ and the open loop gain $G = \frac{\theta_o}{\theta_i - \theta_o} = \frac{A}{1 - A}$

The A and G for each example are given. No attempt is made to solve the various differential equations, and the relevant remarks are most easily checked by applying Bode's decibel-log ω analysis to G .⁴

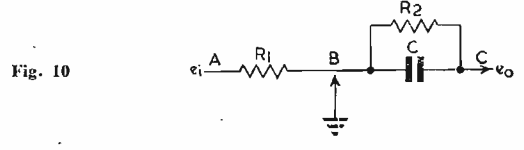
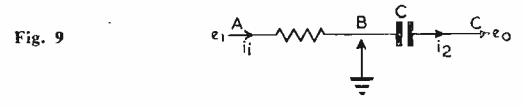
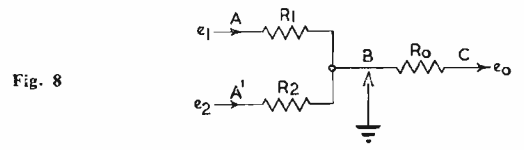

For a simple feedback loop containing two pure integrators only

$$G = \frac{1}{\rho^2 T_3 T_4} \text{ and } A = \frac{1}{\rho^2 T_3 T_4 + 1} = \frac{1}{\rho^2/\omega_o^2 + 1} \dots \dots \dots (3)$$

where $1/\omega_o^2 = T_3 T_4$.

The solution of Equation (3) for a step function is

$$\theta_o = \theta_i (1 - \cos \omega_o t) + \theta_o^1$$

(Assuming the system to be quiescent just before θ_i is applied, θ_o^1 is the datum level of θ_o .)

This systems will therefore perform sinusoidal oscillations of amplitude $|\theta_i|$, about the level of θ_i and starting off in cosine phase from θ_o^1 . Oscillations in θ_o and the outputs of units preceding the integrators are about zero level. In order to make the utmost use of the last integrator without overloading taking place, a step input is used which rises from a negative level (θ_o^1) to zero (level of θ_i).

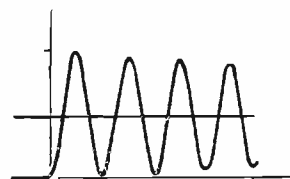

Fig. 11. Second order oscillating closed loop system



Fig. 12. Second order closed loop system critically damped by "viscous friction"

If $T_3 = T_4 = 400 \mu S$, the frequency of oscillation $f_o = \omega_o/2\pi \approx 400 c/s$. This response is shown photographically in Fig. 11. (The slight damping is due to the imperfection of the integrators).

are essentially similar in that they are all feedback amplifiers of the type shown in Fig. 6. This is the well known "see-saw" circuit.¹

The cathode resistor R_o and the screen potential are so adjusted that for zero potential at A , the potential at C is zero. The cathode is at $+e_o$, the grid at zero and by virtue of equal resistors R_p , the potential at D will be 150V. C_s is small and is for transfer of high frequency voltage changes from D to C . It is assumed that R_p and Z_o do not load the amplifier to an appreciable extent.

Let the open loop gain of the amplifier between B and C be $-m$, and let the corresponding voltage disturbances at B and C be Δe_g and e_o due to an input disturbance $+e_i$ at A .

$$\Delta e_g = -e_o/m \text{ and if } m \gg 1, \Delta e_g \rightarrow 0,$$

and the grid remains sensibly constant at zero potential.

A current $i_i = e_i/Z_i$ flows into the grid from the input tending to raise the grid potential towards e_i ; but $e_o = -m\Delta e_g$, so that the potential at C will fall, drawing off current i_o from the grid. As long as $i_i > i_o$ the grid will tend to rise and e_o to fall. A balance is quickly reached when $i_i = i_o$. But since the grid remains sensibly constant at zero potential $i_i = e_i/Z_i$ and $i_o = e_o/Z_o$,
i.e.,

$$e_o = -Z_o/Z_i e_i \dots \dots \dots (1)$$

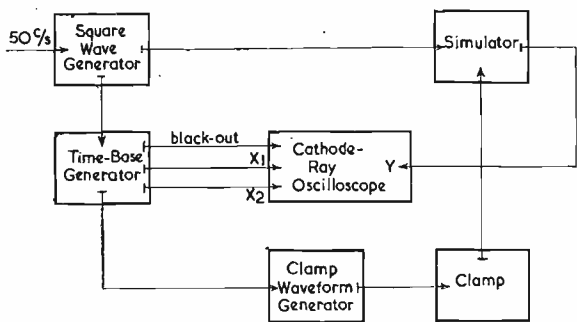
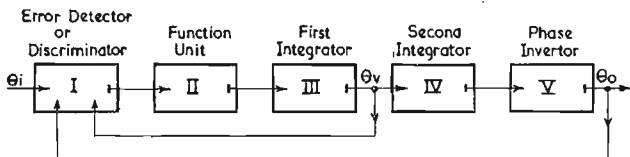

Fig. 4. Block diagram of the complete system

Fig. 5. Block diagram of the simulator



The grid of the amplifier behaves as a "virtual earth"² i.e., any current which flows into the grid flows out again to e_o through the feedback impedance Z_o .

Equation (1) would be exactly true for $m = \infty$. In more accurate simulators m can be increased by using three amplifying stages in the "forward" loop.³

Amplifiers with negative voltage feedback exhibit low output impedance, so the response of one stage is not greatly affected by using it to drive another. However, it is sometimes required of a unit to drive more than one other unit. In this respect the performance can be improved by using the arrangement of Fig. 7, in which a cathode-follower is used to supply the output load. By returning the feedback impedance to the cathode of V_2 the effects of variations of cathode-follower grid base are sensibly eliminated and the output impedance is further

reduced from about $1/g$ to $1/g \cdot \frac{1}{1 + mZ_i/[Z_i + Z_o]}$ and may

thus be of the order of, say, 8 ohms only, with $Z_o = Z_i$, $m = 50$ and $g = 5\text{mA/V}$ (g relates to V_2).

Note that e_o can swing about $\pm 60\text{V}$ before the anode excursion of V_1 ($150\text{V} \pm 120\text{V}$) reaches the distortion limit.

The Error Detector

The function of this unit is to add all the signals put into it into a common output signal.¹ The input and feedback impedances are real (Fig. 8). The arrow represents a virtual earth provided by the circuit of Fig. 7, to which B and C relate, R_o replacing Z_o in that figure. Since any

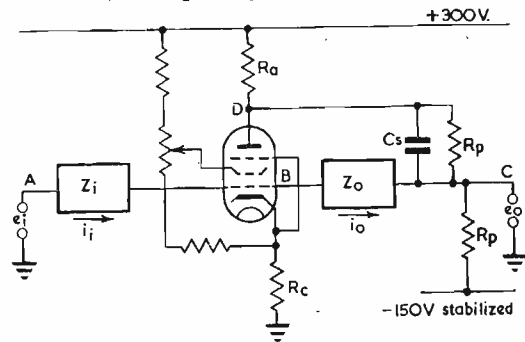

Fig. 6. Circuit diagram of a "unit"

current flowing into the virtual earth flows out again through R_o

$$e_o = -R_o(e_1/R_1 + e_2/R_2 + \dots)$$

Amplification or attenuation may be achieved by varying R_o to a limited extent.

The Integrator

These are wired as Fig. 7, but with $Z_i = R$ and $Z_o = C$ in the simplest case; see Fig. 9 where A , B and C relate to the points in Fig. 7: they are in fact a form of Miller integrator.¹

From the figure $i_i \approx e_i/R \approx i_o \approx -e_o/\rho C$ (where $\rho \equiv d/dt = \text{heaviside operator}$)

$$\text{or } e_o = -\frac{1}{\rho CR} e_i$$

It is usual to choose CR so that the peak magnitude of e_i and e_o are comparable.

This transfer function may correspond either with $\theta_o = \int \dot{\theta}_o dt$ or $\dot{\theta}_o = \int \tau/J dt$ (where $\tau = \text{torque}$ and $J = \text{inertia}$).

In the first case the integration is always "pure" but

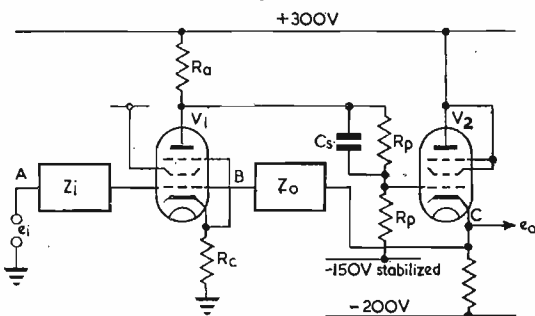

Fig. 7. A "unit" with cathode-follower output

the second may not be, since viscous friction may be present, in which case $\tau = J\rho \dot{\theta}_o + F \dot{\theta}_o$

or

$$\dot{\theta}_o = \tau/F \cdot \frac{1}{1 + J/F \rho} \dots \dots \dots (2)$$

(where $F = \text{viscous friction}$).

This may be simulated by degrading the first integrator as shown in Fig. 10.

A Stabilized A.C. Power Unit

DESIGNED to overcome the difficulties of mains frequency changes, load changes and waveform distortion, Inter Electron Industries stabilized A.C. power unit type 905B also has the advantage that the output voltage may be varied ± 10 per cent by means of a panel control. The unit is robustly constructed to withstand constant handling, and the makers claim that it may be placed in continuous service over long periods of time.

The unit has an output of 500VA at 200 volts. It has a regulation of 0.5 per cent for ± 10 per cent mains change, or 0.5 per cent for ± 10 per cent load change, and is unaffected by mains frequency variations. The waveform gives negligible distortion. The power unit weighs approximately 60lb.

Inter Electron Industries,
7 Chiltern Street,
London, W.1.

V.H.F. Signal Strength Meter

(Illustrated below)

THE new E.M.I. V.H.F. signal strength meter provides a ready means of measuring signal strengths in a given locality, and of checking aerial output and orientation for optimum result.

The signal strength meter covers the frequency range of 40 to 70Mc/s, and is completely portable, having its own vibrator power supply. Essentially it consists of four instruments in one case: a superheterodyne receiver with frequency range of 40 to 70Mc/s; a signal generator with the same frequency range and a calibrated output of 0 to 200 millivolts continuous; a valve voltmeter, and a 2 volt accumulator and vibrator unit for power supply and a charger to re-charge internal accumulator at 2.5 amps from A.C.

In operation the aerial is plugged into the concentric socket on the signal strength meter and the meter pointer is set to zero. The superheterodyne receiver is then tuned in to the transmission under test and the gain control adjusted to bring the meter pointer to reference line. By means of the operational switch, the signal generator output is now switched into the receiver input, and the generator output is adjusted to give the reference reading on the meter. The aerial signal strength is exactly equivalent to the generator output which may be read directly from the calibrated attenuator.

Applications of the V.H.F. signal strength meter include: television aerial installation checking; the determination of signal strengths at various points in a

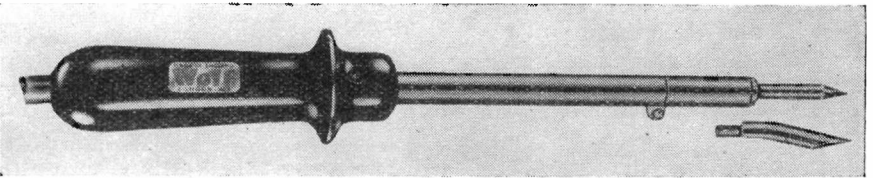
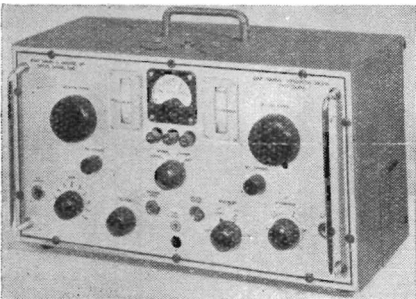

Wolf Electric Soldering Irons

(Illustrated above)

THREE additions have recently been made to the range of Wolf electric soldering irons, types 22, 32 and 42 with the same general features as the original range, but they have conventional straight handles to meet the continued demand for this type of iron.

In keeping with other Wolf models the heating elements are designed to concentrate heat on the working point to provide a rapid and constant heat. A 60/40 solder takes approximately $3\frac{1}{2}$ minutes to melt from cold.

The irons are built to withstand heavy usage, and are fitted with round hardwood handles and a heat deflecting skirt.

Wolf Electric Tools, Ltd.,
Pioneer Works,
London, W.5.

Plessey Shrouded Loudspeakers

(Illustrated below)

THE new range of Plessey shrouded permanent magnet loudspeakers consists of fifty-six alternative units designed to satisfy a wide diversity of requirements. On all models, a choice of cones is available, having performance characteristics adapted for various classes of receivers, including special light-weight cones on the smaller units designed for maximum sensitivity on battery operated sets.

Four circular sizes of loudspeaker, of 5in., 6 $\frac{1}{2}$ in., 8in. and 10in., and one elliptical, of 6 by 4in., are each available in a choice of four flux densities, viz., 7,000, 8,500, 10,000 and 12,000 lines/sq.cm. Both the elliptical and the smallest circular model have $\frac{1}{4}$ in. pole pieces, while that of the largest is 1in. in diameter. The two intermediate sizes may be ordered with either $\frac{1}{2}$ in. or 1in. pole pieces as required.

Employing in each case the Plessey aluminium voice-coil former, centred by means of a diaphragm type rear suspension, these loudspeakers, though normally of 3 ohms impedance, may alternatively be supplied with an impedance value of 5 ohms. Where required, transformer may be factory mounted.

Throughout the range, the method of fixing the top plate and the provision of a dust cap within the pot, protect the pole piece and the air-gap from dust and atmospheric corrosion.

The Plessey Co., Ltd.,
Ilford, Essex.

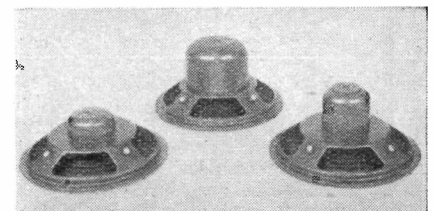

multiple installation, and design and testing of television and short-wave aerials by manufacturers. Also the signal generator section of the complete instrument may be used for the alignment of television and short-wave receivers with an unmodulated signal. The superheterodyne receiver may be used for listening to stations between 40 and 70Mc/s with a pair of headphones plugged into the socket provided. Any 2 volt accumulator may be re-charged by the inbuilt charging unit.

E.M.I. Sales and Service, Ltd.,
Blyth Road,
Hayes, Middlesex.

Miniature Silvered Ceramic Capacitors

SPHERE RADIO, LTD., recently started manufacturing "Jay" miniature silvered ceramic capacitors, in which a low power factor has been achieved which improves as the frequency rises.

The silver electrodes are fused to the specially selected "low-loss" dielectric material, being fired on at a high temperature. This provides a stable, intimately-bonded electrode to the dielectric, enabling the capacitor to withstand severe

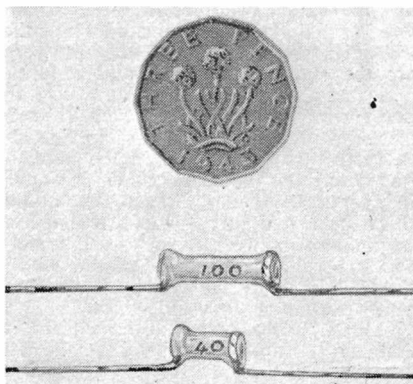

working conditions and retain its stability. "Jay" capacitors in the miniature and small sizes are obtainable in a wide range of capacitances. In the lower ranges, the capacitors can be supplied with a negative temperature coefficient. All "Jay" capacitors, with the exception of the "Servicing" range, are available in a tropical finish.

Illustrated above are two miniature capacitors of the "Servicing" type. The range is available in capacitances of from 1.5pF to 3,000pF, with a power factor at 1kc/15°C of 0.1 per cent up to 100pF, and 2.3 per cent up to 3,000pF. The capacitors of 1.5pF to 47pF and 120pF to 1,000pF are 9.68mm in length, and those of 56pF to 100pF and 1,200pF to 3,000pF 16.05mm, all types having a diameter of 3-15mm.

Sphere Radio, Ltd.,
Heath Lane,
West Bromwich.

Radio Installations: Their Design and Maintenance

By W. E. Pannett. 454 pp., 244 figs., 25 tables. Chapman & Hall, Ltd. 1951. Price 45s.

THE author has been a practising engineer for some thirty years, and as his book testifies, is well qualified to write from the practical man's viewpoint. It is well known that many men have acquired considerable practical "know-how," but are unable to put their knowledge to its best use, because of its incompleteness. This book will enable such gaps in this field to be filled very completely. Although the beclouding effect often produced by introducing theory into this kind of book is admirably avoided—reference only being made to underlying principles where it aids presentation from the practical viewpoint—the author's own theoretical knowledge has enabled him also to avoid making the kind of misleading or ambiguous statements often met in an essentially practical book.

The contents of the book include, in well-balanced presentation: the economics of transmitter siting for various frequency bands; practical aspects of installation layout; power supply and distribution problems; switchboards and cabling; valves and their power supplies; A.C. rectifiers and smoothing filter design; amplifiers, oscillators, transmitters, keying and modulating systems; valve cooling systems; control and protective equipments; radio frequency transmission lines, their termination and switching; communication receivers; radio control centres, and station maintenance and testing, from routine to individual fault locating. An appendix of useful conversion factors, and the well tabulated information distributed throughout the book, make it extremely useful for reference purposes. For its size, the book has few typographical errors.

The reviewer has no hesitation in recommending this book to any engineer, technical assistant, operator or student interested in this field.

N. H. CROWHURST

Semiconducting Materials

Editor: H. K. Henisch. 281 pp. Butterworth's Scientific Publications. 1951. Price 40s.

THIS book, which contains some twenty-five papers on various aspects of semiconduction, represents the subject matter of a conference held at Reading University in July 1950. The papers are contributed by leading workers in the field from Europe and the U.S.A. as well as from this country. It is evident from the text that a large expansion of interest and of knowledge has occurred in this subject during the last decade and particularly since the late war.

Many papers are devoted to the characteristics of silicon and germanium. The germanium transistor triode is now well known as a practical device but its mechanism of power gain is still not completely understood. However, the studies described by members of the Bell Telephone Laboratories, of Purdue University and of the Ecole Normale Supérieure of Paris show that very precise investigations are possible on this type of semiconductor and that some of them are directed towards a clearer understand-

BOOK REVIEWS

ing of the magnification process. The papers of the Purdue group show how the characteristics of germanium crystals can not only be precisely controlled by preparation techniques but also by neutron irradiation of the finished product, the latter giving rise by transmutation to impurity centres in the crystals. This same group has also studied the singular optical characteristics of germanium and silicon in the infra-red region of the spectrum. The transistor action in semiconductors is not now restricted to germanium as shown by its discovery in lead sulphide crystals.

Another series of papers presented deals with rather different types of materials such as the alkali and silver halides, barium and zinc oxides, grey tin, selenium and oxides of the transition elements. We may note here a contribution on alkali halides from Professor Pohl of Göttingen, which includes a report of alpha particle induced conductivity in sodium chloride. The papers on semiconduction in oxides of the transition elements show how, by introducing impurities of definite valency, materials with controllable semiconduction characteristics may be produced. They also show the interesting dielectric and magnetic properties of these oxides. Other materials investigated by the Physics Department of T.R.E. Malvern are the sulphide, selenide and telluride of lead in single crystal and polycrystalline form. Precise studies of optical and electrical properties are again in evidence. A further paper of note in the book is one describing the semiconduction found in evaporated metal films a few atoms thick deposited on glass. The barriers of potential between the relatively widely spaced atoms give rise to activation energies of about 0.0eV. Such films are very transparent to visible light.

Although the text will be chiefly of interest to fundamental workers, it will have a wider appeal since it provides information of a detailed nature on the characteristics of materials which are in many cases of considerable practical importance. No subject index has been provided, but there is no difficulty in locating particular topics by consulting the table of contents.

G. F. J. GARLICK.

Echo Sounding At Sea (British Practice)

By H. Galway. Pp. 299—9. 115 figs. Sir Isaac Pitman and Sons, London, 1951. Price 35s.

THIS book is evidently not intended for the student or development engineer, but almost entirely for the maintenance man; apart from three short introductory chapters, its contents consist of detailed—very detailed—descriptions of some particular commercial echo-sounders and their maintenance, all equipment being of Marconi production

except for one by Hughes. Even wiring diagrams of switches, etc., are included, and of the 300 pages of the book, around 120 are devoted to this sort of descriptive matter. Another 120 or so are devoted to fault-finding procedure, with tabulated summaries for the various equipment.

The first three chapters, covering 53 pages explain in very simple terms—possibly over simplified—some of the basic relationships involved in transmitting sound waves through different media, the construction and operation of piezo-electric and magnets-strictive transducers, and some of the practical considerations involved in fitting a ship with echo-sounding apparatus. The rest of the book is a typical manufacturer's handbook, and, although well-written, would perhaps have been more properly published as such.

It can hardly be expected to have any appeal to the general technical reader, who might have been more interested in what echo-sounders are used for, what knowledge of the sea has been gained by their use, what use has been made of them in the naval service, etc. One is inclined to think the title is misleading; the echo-sounding seems to be done in the training classroom rather than at sea.

The book is well produced but rather expensive.

D. G. TUCKER

Basic Electron Tubes

By D. V. Geppert. 332 pps. McGraw Hill Publishing Co., 1951. Price 42s. 6d.

OF the fourteen books published so far in the McGraw-Hill Electrical and Electronic Engineering series, at least seven are concerned mainly with electronics. The standard of the series has been maintained at a high level but there has been a good deal of duplication of material in the various texts. It is interesting therefore to consider in what way this new volume differs from the others.

The author claims that although there are many good electronic books which cover the circuit applications thoroughly, the tubes themselves have been neglected, except in advanced texts. He has endeavoured to fulfil the need for a book, dealing solely with tubes at a level suitable for the average undergraduate, and yet sufficiently advanced "to give the student a really satisfying treatment of the physics and mathematics of electron tubes." The first objective has been completely fulfilled. The book deals solely with tubes and their inherent characteristics, with no reference to circuits or applications. The treatment is elementary in the main and it is always clear.

Each chapter deals exclusively with one type of tube and a similar treatment is employed in each case. Illustrations and drawings introduce the type of tube, and

these are followed by static characteristics and how to measure them. Then comes a qualitative discussion of the principles underlying the characteristics. Mathematical theory comes at the end of the chapter and is always illustrated by numerical examples which are worked out in detail. This procedure is carried out for eleven chapters dealing with phototubes, hard diodes, triodes, tetrodes and pentodes, beam tetrodes, cathode ray tubes, glow discharge tubes, gas diodes, thyratrons, mercury arc rectifiers and ignitrons.

The general treatment of principles under such headings as electron ballistics has been deliberately avoided. It is claimed that by this method the basic principles are developed as required, and in a manner better suited to the undergraduate's capacity and more likely to arouse his interest. There is much to be said for this approach.

This is a well written, well planned and eminently readable book, providing a sound introduction to electron tubes. The main objection to it from the student's point of view is its cost. Its nature makes it essential to supplement it with a book on circuits, and the combined cost would be excessive for many undergraduates. Surely a first book on electronics should cover both valves and circuits. Indeed the close relationship between valve and circuit is of fundamental importance and some people may feel that a deliberate attempt to dissociate them completely is basically wrong.

M. R. GAVIN

T/V and Other Receiving Antennas

By Arnold B. Bailey. 606 pp., 310 figs. John F. Rider Publisher Inc., New York. 1950. Price \$6.00.

MANY books have been written on the subject of radio propagation and aerial design, but the majority of them demand a high standard of mathematical ability for their full understanding, and this constitutes a serious drawback particularly to the average student.

Mr. Bailey has dealt with the subject in considerable detail using a completely non-mathematical treatment throughout the book, and the result is highly commendable. He commences with a lucid review of definitions and terminology, followed by a description of the television signal and the significance of bandwidth. After a general discussion on the problems involved in television reception as they relate to the radio path and the receiving aerial, he then proceeds to describe the form of the electromagnetic wave and the concept of intrinsic impedance and its effect on wave velocity. This leads naturally to a long chapter on the radio path, dealing with the phenomena of reflexion, refraction and diffraction as they affect propagation, followed by a detailed consideration of the theory of signal interception.

The second half of the book deals in detail with the theory of the basic half-wave dipole in its many forms, and the progressive derivation from this basis of parasitic-element aeriels and complex arrays. Two of the later chapters contain between them data sheets giving concise performance details with polar

diagrams for fifty different aerial configurations.

This book is strongly recommended to the student for its careful and detailed presentation of the subject without invoking the aid of complex mathematics, while it will also prove a valuable reference book to the radio engineer since it contains a considerable amount of useful design data in graphical and tabular form.

For those who wish to extend their knowledge of the subject on more detailed and rigid lines an extensive bibliography is given at the end of each chapter.

K. J. EASTON.

Industrial High Vacuum

By J. R. Davy. 243 pp. Sir Isaac Pitman and Sons. 1951. Price 25s.

THE title of this book is misleading since the major part of its contents deal with the design of high vacuum apparatus and techniques used in the vacuum evaporation process. This technique is now of considerable importance in the manufacture of optical and electronic equipment, and the author of this book has been concerned for several years with the deposition for optical purposes of anti-reflexion films, etc. Unfortunately, the authoritative tone of the book has been weakened by including in its 22 chapters sections on vacuum dehydration, molecular distillation and vacuum metallurgy.

Several books on high vacuum technique have recently been published in which there is a marked similarity between their method of treating the basic high vacuum equipment, e.g., pumps and isolation valves. The student of the subject, who by now must be tired of this constant repetition, will however not find Mr. Davy's book any exception. In fact one of the errors in this book has already been published in at least three other reviews of high vacuum pumps, i.e., on page 12, it is stated that mercury diffusion pumps are "considerably slower than oil pumps of equal size" the fallacy of this was recently exposed in the discussion reports of the High Vacuum Symposium held by the Institute of Physics.

A serious criticism of Chapter 7 on "Mechanisms in Vacuo" is that it mainly catalogues outmoded devices which were developed before the advent of the Wilson and "O" ring type shaft seals, now generally used on kinetic systems. The modified Wilson seal shown in Figure 37 cannot be considered the best arrangement since there is no need to employ a special conical rubber gasket, and facilities for the continuous lubrication of the sealing gasket might have been included. The insulated electrode shown in Figure 39, has to the reviewer's knowledge, not been marketed in that form for several years.

The emphasis given to the glow discharge tube for pressures indication and for leak detection seems over-stressed. Undoubtedly this was a valuable pressure indicator in the early days of vacuum engineering, when high vacuum gauges were easily damaged and often unreliable, but this is no longer true.

CHAPMAN & HALL

Just out

THE MAGNETRON

by

R. A. Latham, M.A., PH.D.
(Imperial College, London)

A. H. King, M.A.
(Clifton College, Bristol)

L. Rushforth, B.SC., M.I.E.E.
(B.T.H. Co., Ltd., Research Laboratory)

152 pages 82 figures 18s. net

POWER SYSTEM ANALYSIS

by

J. R. Mortlock

PH.D., B.SC., M.I.E.E., MEM.A.I.E.E.
(Superintendent Power System Engineering
Dept. B.T.H. Company Ltd.)

and

M. W. Humphrey Davies

M.SC., A.M.I.E.E., ASSOC.A.I.E.E.
(Senior Lecturer in Electric Power
Imperial College, London)

384 pages 200 figures 45s. net

37 ESSEX STREET, LONDON, W.C.2.

The following Reprints from
ELECTRONIC ENGINEERING
are now available

Pre-Amplifiers for the Telesvisor, by
W. I. Flack April, 1950

The Home-Built F.M. Receiver
Reception Tests, by K. R. Sturley,
February, 1951

Piezo-Electric Crystal Devices, by
S. Kelly.
March, April and May, 1951

Mechanized Reasoning, by D. M.
McCallum and J. B. Smith,
April, 1951

Some Aspects of Electrical Computing,
by J. Bell. June and July, 1951

V.H.F. Common Aerial Working,
by E. G. Hamer. July, 1951

An Indoor Television Aerial Array,
by F. E. Wood. July, 1951

An Electrical Digital Computer, by
R. C. Barnes, E. H. Cooke-
Yarborough and D. G. Thomas.
August and September, 1951

Ferranti Nimrod Computer, by R.
Stuart-Williams. September, 1951

Copies can be obtained from

ELECTRONIC ENGINEERING
28 ESSEX ST., STRAND, LONDON, W.C.2

Price 9d. each, postage 1½d.

BOOK REVIEWS (Continued)

PUBLICATIONS RECEIVED

Reference is not made to the Pirani method of leak detection employing a hydrogen probe, nor to the more sensitive palladium window ionization gauge, yet a short description of the mass spectrograph is given.

The suggestion in chapter 9 that neon sign transformers are suitable as high tension sources for ionic bombardment cleaning cannot be accepted. This type of transformer can only be used for operating a glow discharge in which one electrode is grounded since the centre tapping of the transformer is always earthed. Consequently there is always the risk, admitted by the author on page 82, of substrate contamination by sputtered films removed from the earthed chamber fittings, since these are cathode electrodes on alternate discharge cycles. Earthed A.C. power supplies also facilitate the entry of the glow discharge into the pumping orifice and, although the reader is warned to use wire mesh shields, this is unsatisfactory because of the reduction of the pumping speed. The better H.T. practice, which might have been recommended, is the use of either a rectified supply with a grounded anode or an A.C. supply with both output terminals insulated from earth.

A great deal has been done to establish the evaporation process on a scientific foundation but much remains in deposition technique which is still an "art"! It is therefore probable that many workers will disagree with the opinions expressed on the effect of deposition rate and source temperature on film structure, e.g., see page 133. The author has not critically compared his results with those of other workers and there is also inadequate reference in the text to the immense literature on this subject.

Disagreement will also arise over the use of the term "reflexion" to describe the formation of films on surfaces not facing the vapour source, e.g., on page 157 it is stated that M_2F_2 "vapour . . . may reflect off the top of the tank" and similar statements are made regarding aluminium vapour on pages 134 and 176. While it is true that under certain circumstances atoms may not condense on single impact, i.e., low beam intensity and high substrate temperature, the term "reflexion" is incorrect since the process is one of absorption and re-evaporation as demonstrated by Languir in 1913. If, however, a film is condensed on the top of a work chamber, the presence of which is often visible, it is quite improbable that succeeding atoms will re-evaporate since the binding forces between the freshly deposited film and impinging vapour atoms will be extremely high. A more satisfactory explanation of back deposit is that the propagation of the vapour beam is diffuse, because of the scattering action of inter-molecular collisions, e.g., between vapour atoms at high vapour pressures, and between vapour

atoms and gas molecules when the pressure in relation to transit path is high.

The evaporation of metal oxides for interference filters is of wide interest and a more complete treatment of this could have been made. The statement on page 182 that Fe_2O_3 can be deposited to form "stable layers" requires amplification, since films of mixed lower oxides are deposited if Fe_2O_3 is vapourised at 10^{-4} mm Hg. Titanium dioxide, as stated, is reduced when heated to a lower oxide but TiO_2 films can be condensed if the reduced oxide is vapourised slowly. Mention could also have been made of the indirect methods of preparing TiO_2 by baking titanium metal films in air.

It is a pity that although the measurements of thickness is mentioned no reference is made to the multiple beam interferometric method which has proved so far to be the most reliable technique developed.

The applications of vacuum evaporation have grown tremendously in recent years and a book in this field has been badly needed to supplement the earlier admirable contribution of J. Strong. Consequently the book reviewed can be expected to enjoy a wide popularity, and it is hoped that many of the errors and speculations in the subject matter, some of which have been mentioned in this review, will be corrected in future editions.

L. HOLLAND.

Quarterly Journal of Mechanics and Applied Mathematics

Vol. IV. Part 2. Oxford University Press. June, 1951. Price 12s. 6d.

THE "random walk" problem is a classical problem in the theory of probability. It is the problem of finding the distribution of a number of men in a line, where each has made n equal steps of length a with an equal probability that each step is to the right or the left. In 1922, Professor G. I. Taylor considered an extension of the problem where the probabilities of the steps being to the right p or left $(1-p)$, for each step, are always the same, but not equal. (p not one-half). The problem is considered in more detail in this Journal by Professor S. Goldstein, who finds that for very large values of n and very small values of a , an equation for the distribution function in terms of the distance gone and for the number of steps is just the same as the telegraph equation with resistance, capacity and inductance, but no leakage. The equation with leakage is obtained as a further extension, when there is a finite probability that at the end of each step a man may fall through a hole.

G. J. KYNCH.

ELECTRODEPOSITED TIN-NICKEL ALLOY COATINGS, by N. Parkinson, M.Sc., A.R.I.C., S. C. Britton, M.A., and R. M. Angles, L.I.M.C., is a booklet issued by the Tin Research Institute, Fraser Road, Perivale, Greenford, Middlesex, describing the newly invented tin-nickel electroplate. This electroplate remains permanently bright when exposed to the atmosphere or to many liquids and sprays that corrode other metals. Its resistance is such that it can be classed as a material suitable for the construction of chemical engineering plant.

BROADCAST RECEPTION—SOUND AND TELEVISION BY RADIO is the final form of Code 327.201 issued by the Council for Codes of Practice. This Code forms part of the series dealing with telecommunication services in buildings, and sets out recommendations for good reception of sound broadcasts on the three wavebands, and of television broadcasts. It includes suggestions for the provision of suitable aerial systems, and attention is given to measures for reducing the effect of electrical interference. Power supplies and wiring are also dealt with. Appendices deal with the segregation of telecommunication circuits and with special types of cables, including radio-frequency feeders. Copies may be obtained from the British Standards Institution, 24-28 Victoria Street, London, S.W.1, price 6s. post free, reference CP.327.201(1951).

MINIATURE BEARINGS CATALOGUE NO. 4 has been issued in a second edition by the Miniature Ball Bearings Co. of Bienne, Switzerland. The principal changes from the 1949 edition concern precision steel balls, steel rollers, sealed ball bearings, and roller bearings. Copies in this country can be obtained from Miniature Bearings Ltd., 192 Stoa Street, London, S.W.1.

USES FOR TUFNOL is a recent publication designed to show some of the fields in which this material can be applied. Tufnol is a non-metallic material resembling horn or hardwood in appearance, but machines more easily than metal, is hard wearing and strong, and about half the weight of aluminium. In radio and electronics it has been used for insulators and insulating sleeves, terminal boards, valve holders, coil bases and formers, plug leads, spiders for loudspeaker assembly, etc. Tufnol Ltd., Perry Barr, Birmingham 22B.

DRY ELECTROLYTIC CAPACITORS FOR MOTOR STARTING and **MARK 51 HUNTING-RAM CAPACITORS FOR RADIO FREQUENCY APPLICATIONS** are two leaflets recently produced by A. H. Hunt Ltd., of Bendon Valley, Garratt Lane, London, S.W.18, to cover special types of capacitors for industrial and electronic applications.

HIGH NICKEL ALLOYS FOR HEAT-RESISTING EQUIPMENT is a publication issued by Henry Wiggin & Co. Ltd., Wiggin Street, Birmingham, 16, which discusses the high temperature properties of Nimonic 75, Inconel, Nimonic D, Mangonic and pure wrought nickel. By quoting actual uses it gives guidance to the most economical choice of material for a given set of conditions of temperature, loading and requisite life.

MORGANITE BRUSHES—MOUNTING AND MAINTENANCE is a booklet issued by the Morgan Crucible Co. Ltd., Battersea Church Road, London, S.W.11, to help users of their brushes obtain the maximum efficiency from them, and deals mainly with brush operation on commutators and slip rings.

DEAFNESS DEFEATED BY OSSICAIDE is a well produced brochure which describes various types of deafness and the relevant Ossicaide hearing aids available to counteract them. Ossicaide Hearing Aids, 22-24 Kensington Church Street, London, W.8.

WIGGIN NICKEL ALLOYS NO. 331 contains articles on forming by spinning and on high nickel alloy spring materials. Other subjects covered also include: corrosion problems involved in using potassium dichromate and phosphorus oxychloride; nickel alloys used in thermal de-icing; industrial drying; gas safety devices, and vapour spray cleaning apparatus. Henry Wiggin & Co. Ltd., Wiggin Street, Birmingham, 16.

NOTES FROM THE INDUSTRY

Convention on "The British Contribution to Television." The Institution of Electrical Engineers is organizing this convention from 28 April to 3 May, and all those interested should apply to the Secretary for copies of the programme and a combined registration and order form. Overseas visitors will be especially welcome.

It is expected that there will be between 60 and 80 technical papers on which discussion can take place, and advance copies, in proof form, of all papers will be available in April to all those signifying their requirements on the registration and order form. After the Convention there will be four issues of Part IIIA of *The Proceedings of the Institution of Electrical Engineers* containing the proceedings of the Convention, including addresses and the full text of all papers with the discussions and authors' replies.

During the technical sessions, which will cover all aspects of television from the programme production to the viewer, there will be interesting demonstrations of television equipment, including large-screen projection television and, it is hoped, an early Baird 30-line equipment, which is at present being reassembled. During the Convention there will be arranged visits of inspection, open only to registered members and their ladies, which will include B.B.C. television studios and the latest television transmitters, the Post Office Research Station, the terminal equipment of the London-Birmingham co-axial cable link, and, on a limited scale, to certain commercial organizations. In addition, a number of social functions are being arranged, to which it is hoped registered members will bring their ladies.

The sessions into which the Convention will be divided are: the opening ceremony, followed by an introductory survey paper by Sir Noel Ashbridge; a historical paper showing the evolution of television; programme origination; point-to-point transmission; broadcasting stations; propagation; receiving equipment, sub-divided into two parts on receiver circuit techniques and cathode-ray tubes and valves; non-broadcasting applications, and system aspects to cover the fundamental aspects of colour television, test equipment, subjective aspects of viewing, contrast, etc.

Leicester College of Technology and Commerce Library. A new library for students in all branches of engineering is being opened at the College of Technology and Commerce. The librarian is anxious to obtain a comprehensive collection of trade catalogues, instruction handbooks and house journals for use in this library, and they should be sent to the Chief Librarian, College of Technology and Commerce, Lero Buildings, Painter Street, Leicester.

The Royal Society Officers and Council. Professor E. D. Adrian, O.M., has been elected President of the Royal Society for the ensuing year, Sir Thomas Merton Treasurer and Vice-President, Sir Edward Salisbury, C.B.E., and Sir David Brunt Secretaries and Vice-Presidents, and Sir Cyril Hinshelwood Foreign Secretary. Also elected Vice-President is Sir Howard Florey. Other members of the Council are: Dr. R. W. Bailey, Dr. O. M. B. Bulman, Professor P. A. Buxton, C.M.G., Sir John Cockcroft, C.B.E., Dr. I. de B. Daly, Professor E. C. Dodds, M.V.O., Professor M. G. Evans, Mr. P. Hall, Sir Geoffrey Jefferson, C.B.E., Professor E. J. Maskell, Dr. W. G. Penney, O.B.E., Professor H. H. Plaskett, Dr. R. Stoneley, Professor A. R. Todd and Professor J. Z. Young.

Radio Exports Increased. Exports of British radio equipment of all kinds in November last were valued at £2,235,367—as much as in a year before the war—bringing the total for the first eleven months of 1951 to £20,446,795, compared with £17,750,000 for the whole of 1950. The value of radio receivers exports increased in 1951 to about £5,000,000, and the first exports of television receivers also took place during the year. Valves were exported to the value of £3,755,000, and components to the value of more than £7,000,000, ten per cent of the components going to dollar markets. These figures are based on the Customs and Excise figures for the first eleven months of 1951.

Atomic Energy Reports. Arrangements have been made by the Ministry of Supply and H.M. Stationery Office for suitable unclassified, as well as declassified, reports from the A.E.R.E. to be available for public sale.

All the reports have been carefully examined to ensure that they contain only information which may be released according to rules laid down in the Declassification Guide, agreed to and used by the U.K., the U.S.A., and Canada. The titles of the reports available will be listed by H.M.S.O. in the Daily List of Government Publications, and quarterly lists will be issued by the Ministry of Supply. The price of reports will be approximately 2d. a page, and orders should be addressed to H.M.S.O., Sales Division, Cornwall House, Stamford Street, London, S.E.1.

Copies of these reports will also be deposited with the following reference libraries: the Science Library, South Kensington; the Radcliffe Science Library, Oxford; the Patent Office Library; the British Museum Library; the National Library of Scotland, Edinburgh; the National Library of Wales, Aberystwyth; the University Library, Cambridge, and the Board of Trade Technical Information and Documents Unit.

Lectures on Electronic Computing.

The Department of Electrical Engineering of the South-East London Technical College, Lewisham Way, London, S.E.4, is offering a course of lectures on "Electronic Instruments and Applications" by O. Davie, A.M.I.E.E., H. I. Heath, B.Sc.(Eng.), A.M.I.E.E., and R. C. Orford, B.Sc.(Eng.), A.M.I.E.E. The second part of this course takes the form of six lectures on electronic computing, which will take place every Tuesday evening at 7 p.m. from 4 March to 8 April. The charge for the six lectures is 12s. 6d. Application for enrolment should be made to the Head of the Electrical Engineering Department, from whom a syllabus may be obtained.

E. K. Cole, Ltd. Board Appointments.

Messrs. E. K. Cole, Ltd. announce that the following executives of the company have been appointed directors: Mr. F. S. Allen, M.I.P.E., Mr. J. Corbishley, A.C.A., and Mr. A. W. Martin, M.B.E., Assoc.I.E.E. The following executives have been appointed executive directors: Mr. G. W. Godfrey, M.I.S.M.A., Mr. D. Radford, and Mr. W. M. York, F.I.A.M.A., M.I.S.M.A.

A. H. Hunt, Ltd. Change of Name.

At an extraordinary general meeting held recently, it was decided that the registered name of this company should include a reference to the products in which they specialize. Therefore, the name has now been changed to A. H. Hunt (Capacitors), Ltd.

Mr. H. T. Parker, who joined the Plessey Co., Ltd. five years ago to form their Sales Promotion Department, and who has been General Manager of the Marketing Division for fifteen months, is to leave the full time employment of the company. He will, however, continue to operate as Publicity Advisor to the Board, but this arrangement will leave him free to extend other interests in the advertising and sales promotion fields.

Second British Plastics Exhibition and Convention.

Following the success of the first British Plastics Exhibition and Convention held in June, 1951, it has been decided to hold a similar convention and exhibition in 1953, the exact dates to be announced later. This event will again have the full support and co-operation of the British Plastics Federation. The organizers are *British Plastics*, Dorset House, Stamford Street, London, S.E.1.

Erratum. In the December, 1951 issue on page 496 there appeared a review of "Pianos, Pianists and Sonics" by G. A. Briggs. This book was published by Wharfedale Wireless Works, of Idle, Bradford, at 10s. 6d., not by Chapman and Hall, Ltd., at 21s.

MEETINGS THIS MONTH

THE BRITISH INSTITUTION OF RADIO ENGINEERS

London Section
Date: February 20. Time: 6.30 p.m.
Held at: School of Hygiene and Tropical Medicine, Keppel Street, Gower Street, W.C.1.
Lecture: Search Radar for Civil Aircraft.
By: P. L. Stride.

Scottish Section
Date: February 7. Time: 7 p.m.
Held at: the Royal Technical College, Glasgow.
Lecture: Some Special Oscillograph Techniques.
By: Professor F. M. Bruce, D.Sc.
Date: February 14. Time: 7 p.m.
Held at: the Natural Philosophy Department, The University, Edinburgh.
Lecture: the Clerk-Maxwell Memorial Lecture.
By: Professor G. W. O. Howe, D.Sc., Ll.D.
Date: February 27. Time: 7 p.m.
Held at: the Institute of Engineers and Ship-builders, Glasgow.
Lecture: V.H.F. Broadcasting.
By: Paul Adorian, M.Brit.I.R.E.

South Midland Section
Date: February 13. Time: 7.15 p.m.
Held at: Corporation Street Civic Restaurant, Coventry.
Lecture: Gas Discharge Devices as Switching Elements.
By: E. A. R. Peddle, B.Sc.

North Eastern Section
Date: February 13. Time: 6 p.m.
Held at: the Neville Hall, Newcastle-upon-Tyne.
Symposium of papers by students.

West Midlands Section
Date: February 26. Time: 7 p.m.
Held at: Wolverhampton and Staffordshire Technical College.
Lecture: Valve Manufacture.
By: C. C. Vodden, M.Sc.

THE BRITISH SOUND RECORDING ASSOCIATION

Date: February 15. Time: 7 p.m.
Held at: the Royal Society of Arts, John Adam Street, W.C.2.
Lecture: Testing and Adjusting Magnetic Tape Recorders.
By: H. J. Houlgate, A.M.I.E.E.

Portsmouth Centre
Date: February 14. Time: 7.30 p.m.
Held at: the Central Library, Guildhall Square, Portsmouth.
Lecture: Development of Magnetic Tape Recorders.
By: J. Collinson.

THE ELECTRO PHYSIOLOGICAL TECHNOLOGISTS' ASSOCIATION

Date: February 9.
Held at: the Maïda Vale Hospital, London, W.9.
General Meeting with papers and demonstrations on electro physiology.

THE INSTITUTE OF NAVIGATION

Date: February 15. Time: 5 p.m.
Held at: the Royal Geographical Society, 1 Kensington Gore, London, S.W.7.
Lecture: Navigation Aids for Military Aircraft.
By: S/Ldr. D. Bower.

THE INSTITUTE OF PHYSICS

Electronics Group
Date: February 19. Time: 5.30 p.m.
Held at: the Institute of Physics, 47 Belgrave Square, London, S.W.1.
Lecture: The Mechanism of Radiation-Induced Chromosome Mutation.
By: Dr. J. M. Thoday.

Scottish Branch
Date: February 12. Time: 7 p.m.
Held at: The University, Glasgow.
Lecture: Electron Microscopy.
By: Dr. V. E. Cosslett, F.Inst.P.
Date: February 13. Time: 7 p.m.
Held at: The University, Edinburgh.
Lecture: as in Glasgow.

Manchester Branch
Date: February 15. Time: 7 p.m.
Held at: The University, Manchester.
Lecture: Counting Methods.
By: Dr. J. D. Craggs, F.Inst.P.

Midland Branch
Date: February 28. Time: 5 p.m.
Held at: The University, Edgbaston, Birmingham.
Lecture: Some Applications of Physics to Medicine.
By: Professor F. W. Spiers.

THE INSTITUTION OF ELECTRICAL ENGINEERS

All London meetings, unless otherwise stated, will be held at the Institution, commencing at 5.30 p.m.

Date: February 7.
Lecture: The Economics of Low-Voltage Electricity Supplies to New Housing Estates.
By: F. G. Copland, B.Eng. (Supply Section Paper).
Date: February 11.
Informal Discussion: Merit Rating and Job Evaluation.
Opened by: J. J. Gracie, C.B.E.
Date: February 12. Time: 5.30 p.m.
Held at: Central Hall, Westminster, S.W.1.
Faraday Lecture: Sound Recording—Home, Profession Industrial and Scientific Applications. (Admission by ticket, obtainable from the I.E.E.)

Radio Section
Date: February 13.
Lecture: Factors Affecting the Design of the Automatic Electron Trajectory Tracer.
By: K. F. Sander, M.A., Ph.D., C. W. Oatley, M.A., M.Sc., and J. G. Yates, M.A.
Date: February 25.
Debate: In the Opinion of this House, the Lone Worker can no longer make a Major Contribution to Radio Development.

Measurements Section
Date: February 19.
Lecture: The Automatic Compensation of Zero-Drift Errors in Direct-Coupled Feedback Systems.
By: F. A. Summerlin.
Lecture: High-Gain D.C. Amplifiers.
By: K. Kandiah and D. E. Brown.
Lecture: Design of a Practical D.C. Amplifier based on the Second-Harmonic Type of Magnetic Modulator.
By: S. W. Nobel and P. J. Baxandall, B.Sc.(Eng.).

Education Discussion Circle
Date: February 22.
Discussion: Engineering Graduation Theses at the University of Cape Town.
Opened by: Professor B. L. Goodlet, O.B.E., M.A.

East Midland Section
Date: February 28. Time: 7.30 p.m.
Held at: Corn Exchange, Spalding.
Informal Discussion: Outdoor Substations up to 11kV.
Opened by: A. E. Strong.

Cambridge Radio Group
Date: February 5. Time: 6 p.m.
Held at: The Cambridgeshire Technical College, Cambridge.
Lecture: Colour Television.
By: L. C. Jesty, B.Sc.

Mersey and North Wales Centre
Date: February 18. Time: 6.30 p.m.
Held at: the Liverpool Royal Institution, Colquitt Street, Liverpool.
Lecture: The Characteristics and Control of Rectifier-Motor Variable-Speed Drives.
By: P. Bing'ey.
Date: February 25. Time: 7 p.m.
Held at: Carter's Cafe, Bridge Street, Warrington.
Lecture: Earthing.
By: P. W. Cave, B.Sc.

North-Eastern Centre
Date: February 25. Time: 6.15 p.m.
Held at: Neville Hall, Westgate Road, Newcastle-upon-Tyne.
Lecture: Electricity in Newspaper Printing.
By: A. T. Robertson.

North Eastern Radio and Measurements Group
Date: February 4. Time: 6.15 p.m.
Held at: King's College, Newcastle-upon-Tyne.
Lecture: An Investigation into the Mechanism of Magnetic-Tape Recording.
By: P. E. Axon, O.B.E., M.Sc.
Date: February 18. Time: 6.15 p.m.
Held at: King's College, Newcastle-upon-Tyne.
Address by the Chairman of the Radio Section.
By: D. C. Espley, O.B.E., D.Eng.

North Western Radio Group
Date: February 20. Time: 6.15 p.m.
Held at: the Engineers' Club, Albert Square, Manchester.

Lecture: A Review of Some Television Pick-up Tubes.
By: J. D. McGee, M.Sc., Ph.D.

North Lancashire Sub-Centre
Date: February 27.
Held at: Queen Street Library, Backpool.
Lecture: Electricity in Newspaper Printing.
By: A. T. Robertson.

Northern Ireland Centre
Date: February 15.
Held at: the Grand Central Hall, Belfast.
Annual Conversazione and Visit of the President.

Scottish Section
Date: February 13. Time: 7 p.m.
Held at: the Heriot-Watt College, Edinburgh.
Lecture: The London-Birmingham Television Radio and Relay Link.
By: R. J. Clayton, M.A., D. C. Espley, O.B.E., D.Eng., G. W. S. Griffiths and J. M. C. Pinkham, M.A.
Date: February 26. Time: 7 p.m.
Held at: the Institution of Engineers and Ship-builders, Glasgow.
Lecture: The Inductor Compass.
By: A. Hine, B.Sc Tech.

South Midland Radio Group
Date: February 25. Time: 6 p.m.
Held at: the James Watt Memorial Institute, Great Charles Street, Birmingham.
Lecture: Trunks Radio Systems.
By: D. C. Espley, O.B.E., D.Eng. (Radio Section's Chairman's Address).

Southern Centre
Date: February 6. Time: 6.30 p.m.
Held at: the Royal Beach Hotel, Portsmouth.
Lecture: A New Power Stroboscope for High-Speed Flash Photography.
By: W. D. Chesterman, B.Sc., D. R. Clegg, G. T. Peck and A. J. Meadowcroft.

Western Centre
Date: February 11. Time: 6 p.m.
Held at: the South Wales Institute of Engineers, Park Place, Cardiff.
Lecture: The Sutton Coldfield Television Broadcasting Station.
By: P. A. T. Bevan, B.Sc., and H. Page, M.Sc.

South Western Sub-Centre
Date: February 20. Time: 4 p.m.
Held at: Standard Telephones Works Canteen, Ilminster.
Lecture: Properties of Bariumtitanium Materials.
By: Professor Willis Jackson.

THE INSTITUTION OF ELECTRONICS

North-Western Branch
Date: February 20. Time: 7 p.m.
Held at: the College of Technology, Manchester.
Lecture: Development of Multi Range Electronic Measuring Instruments.
By: S. R. Wilkins, M.Brit.I.R.E., A.I.E.E.

THE INSTITUTION OF POST OFFICE ELECTRICAL ENGINEERS

Date: February 12. Time: 5 p.m.
Held at: The I.E.E., Savoy Place, W.C.2.
Lecture: Some Applications of Cold Cathode Tubes in Switching Circuits.
By: J. A. Lawrence, A.M.I.E.E.
Date: February 27. Time: 5 p.m.
Held at: the Conference Room, 4th Floor, Waterloo Bridge House, S.E.1.
Lecture: Television Interference.
By: J. S. Hizzey and J. R. Turner.

THE RADIO SOCIETY OF GREAT BRITAIN

Date: February 29. Time: 6.30 p.m.
Held at: the I.E.E., Savoy Place, W.C.2.
Lecture: Modern Valves for V.H.F. Work.
By: a member of the staff of Mullard Ltd.

THE TELEVISION SOCIETY

Date: February 14. Time: 7 p.m.
Held at: C.E.A., 164 Shaftesbury Avenue, London, W.C.2.
Lecture: In Search of the Perfect Raster.
By: P. J. Edwards.
Date: February 29. Time: 7 p.m.
Held at: C.E.A., 164 Shaftesbury Avenue, London, W.C.2.
Lecture: Television Receiver Design.
By: J. E. Hillyer and A. E. Howard.

The ultimate in fine reproduction

Stentorian **CONCENTRIC DUPLEX**



The high-fidelity performance of these speakers has amazed even the experts. Their construction and performance are fully described and illustrated in two leaflets, available on request. These also describe the distinguished cabinets which are available for both models.

12" model: series gap magnet Alcomax 3. Total magnetic flux 220,000 lines. Frequency coverage 30-17,000 c.p.s. Power handling capacity 15 watts. Chassis material Mazak 3. 12" Chassis with Cross-over Network £17.17.0; 10" Chassis with condenser £6.15.0; matching transformers available at extra cost.

... and a speaker for every need

The reasons for the unique quality of reproduction given by W.B. chassis are two — firstly, because the actual designers of the first great W.B. moving coil speaker over 25 years ago are still personally engaged in improving "Stentorians". Secondly, because all operative parts — "Alcomax" magnet, graduated multi-fibre cone, speech coil assembly, transformer — are designed and made in the one organisation, under the same knowledgeable supervision. P.M. Units from 2½" to 12".

WHITELEY ELECTRICAL RADIO CO. LTD · MANSFIELD · NOTTS

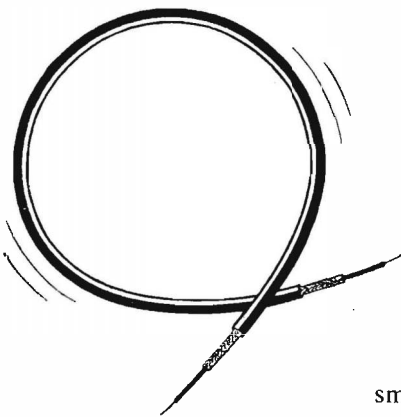

non-microphonic cables

In certain applications of small flexible cables it has been found that the cable itself is the source of minute parasitic voltages, generated chiefly when the cable is flexed, vibrated or knocked. This is important in the case of leads carrying very small signals, of the order of say, 10^{-10} amps.

Telcon offers a new range of cables having a Telcothene insulant provided with a low-resistive covering adhering to the cable core immediately under the braid. With this construction it has proved possible to utilise the extremely good electrical and mechanical properties of Telcothene and at

the same time reduce these troublesome parasitic voltages to a level lower by 20-50 db, compared with normal polythene cables.

The following standard cables incorporating this refinement are available: K.16.GM, PT.1.GM, PT.11.GM. *Further particulars on application.*

TELCON **cables**



THE TELEGRAPH CONSTRUCTION & MAINTENANCE CO. LTD
 Head Office: 22 OLD BROAD STREET, LONDON, E.C.2. Telephone: LONDON Wall 7104
 Enquiries to: TELCON WORKS, GREENWICH, S.E.10. Telephone: GREEnwich 3291

BAKER PLATINUM LIMITED

deoxo

Catalytic Gas Purifier

The Baker 'Deoxo' Gas Purifier provides a highly efficient and trouble-free catalytic method of removing unwanted oxygen from hydrogen. Also the removal of either of these gases from Nitrogen, Argon, Helium, Neon, Carbon Dioxide, and saturated hydro-carbons.

The 'Deoxo' standard Purifier will remove up to 1% oxygen or 2% hydrogen. High purity is consistently produced, the remaining impurity being less than one part per million (.0001%).

OPERATIONAL ADVANTAGES

As catalytic reaction commences at room temperature, this purification system offers the following advantages:—

NO auxiliary heating required • NO water cooling required • NO operating expenses • NO maintenance expenses.



A copy of the illustrated publication, giving full details of the 'Deoxo' process, will be forwarded on application.

Technical representatives are always available for consultation and advice.

BAKER PLATINUM LIMITED
52 HIGH HOLBORN, LONDON, W.C.1

Telephone: CHAncery 8711

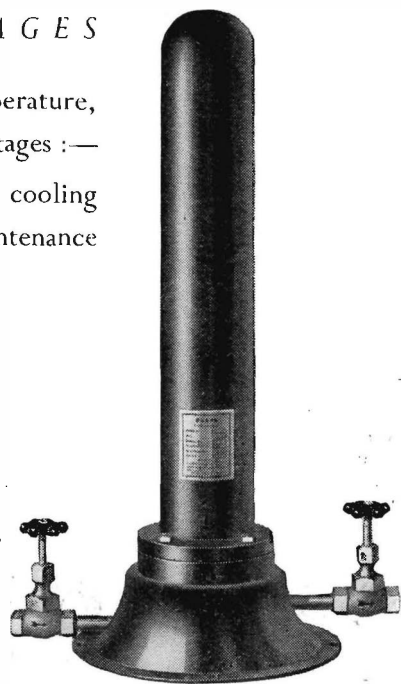

'Deoxo' 200-50 Model

Recently released by the B.B.C.—
the finest moving-iron cutterhead yet
available . . .

B.B.C. TYPE

Negative Feedback

RECORDING CUTTERHEADS

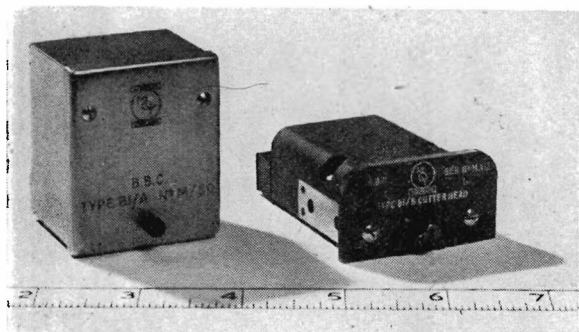

- Temperature effect reduced by Silicone damping.
- Frequency response, 2db 50c/s 15Kc/s.
- Vertical and horizontal patterns
- Standard or modified types for velocities up to 21cm/sec. r.m.s.

Send for our new illustrated 34 page book, giving details and circuit diagrams of amplifiers suitable for use with these cutterheads. Useful recording data and tables. post free **5/-**

Sole Distributors:

GRAMPIAN REPRODUCERS
LIMITED

11, HANWORTH TRADING ESTATE · FELTHAM · MIDDX.

Phone : Feltham 2657.

Grams : REAMP, Feltham.

WIDE RANGE NAGARD TYPE 103 OSCILLOSCOPE AND WAVE FORM MONITOR

NOW IN CONVENIENT FORM. A VERSATILE
AND ACCURATE RESEARCH TOOL FOR THE
PROBLEMS OF TODAY AND TOMORROW.

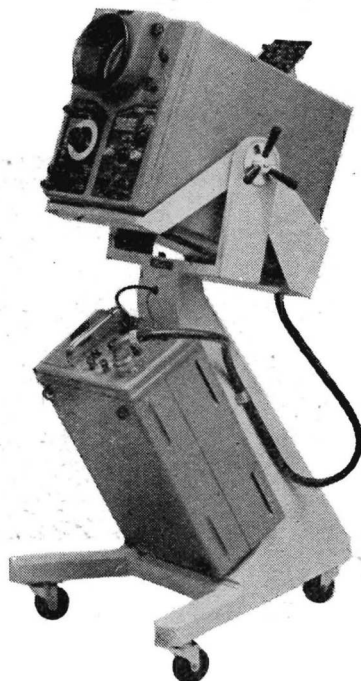

See **TRULY** what you measure !

HIGH GAIN D.C. AMPLIFIERS interchangeable.
HIGH FREQUENCY D.C. AMPLIFIER—0-10 Mc/s.
HIGH SPEED TIME BASE—55 m.m. per u sec.
LOW SPEED TIME BASE—50 m.m. per sec.
HIGH STABILITY AGAINST MAINS CHANGES.
HIGH ACCURACY OF CALIBRATION AND CONTROL.
FLAT SCREEN C.R.T.—6" diam.

QUICK DELIVERIES NOW AVAILABLE FROM IMPROVED
PRODUCTION AT OUR NEW FACTORY.

NAGARD
LTD

18, AVENUE ROAD, BELMONT, SURREY.

Phone: VIGILANT 0345.

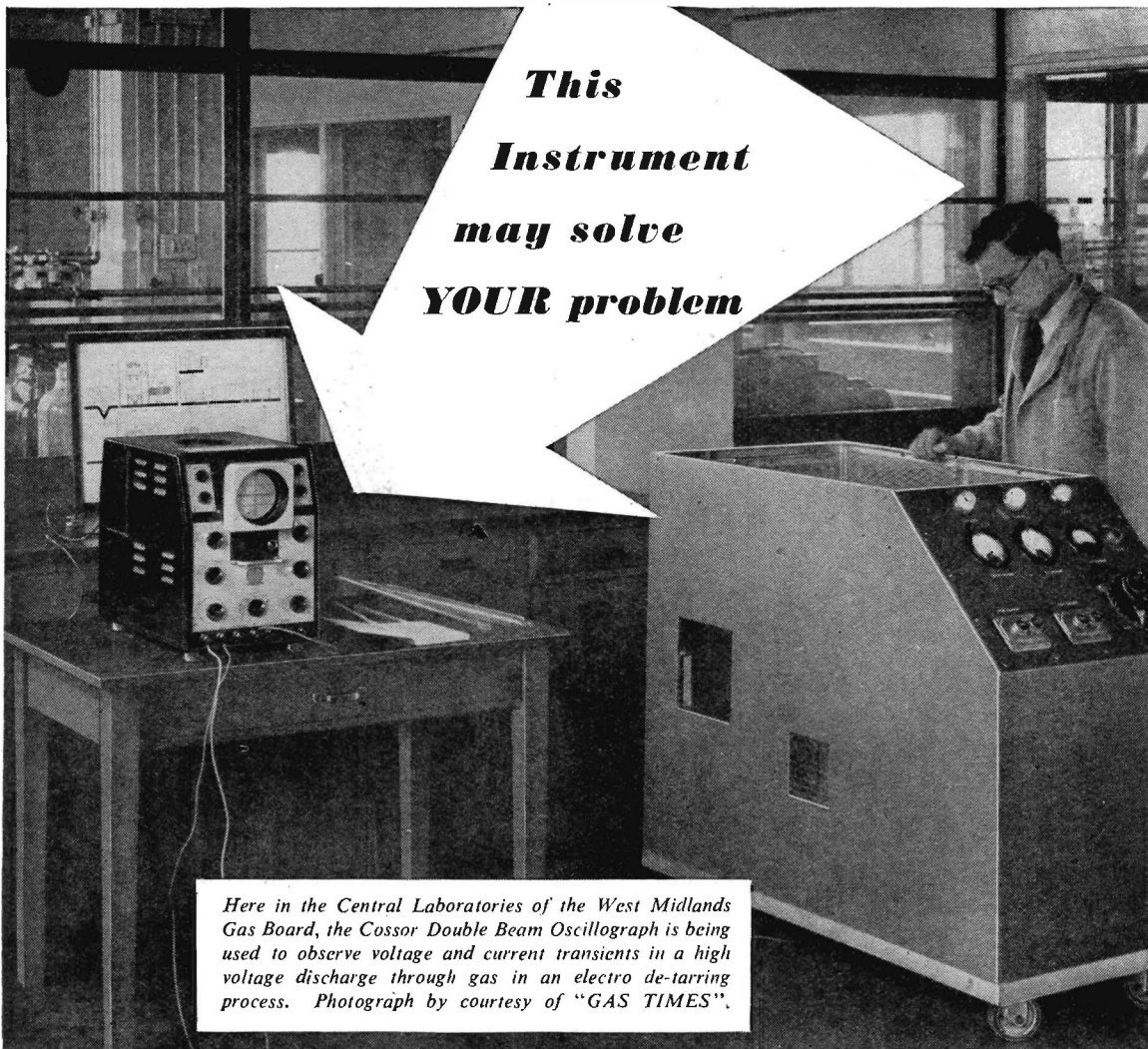

**This
Instrument
may solve
YOUR problem**

Here in the Central Laboratories of the West Midlands Gas Board, the Cossor Double Beam Oscillograph is being used to observe voltage and current transients in a high voltage discharge through gas in an electro de-tarring process. Photograph by courtesy of "GAS TIMES".

Designed by electronic engineers who are intimately concerned with the problems which technicians have to face, the Cossor Double Beam Oscillograph will enable the waveforms of two related though *independent* phenomena to be examined *simultaneously*. Many industries, ranging from nylon spinning to the manufacture of jet engines, are today using this versatile instrument for an inexhaustible variety of functions in research and production, and it often provides the answer to a long-standing problem. Please consult our technical advisory staff who are always at your service to help with *your* particular problem.

Here are some brief details: The two traces are presented on a flat screen of 90 mm. diameter and the calibrated controls of the instrument enable the measurement of the input voltage to each amplifier as well as the Time interval between various significant portions of the Oscillogram. Permanent records of these traces for subsequent analysis may conveniently be made by attachment of the Cossor Model 1428 Camera.

COSSOR

Double Beam OSCILLOGRAPHS

Please address enquiries:

A. C. COSSOR LTD., INSTRUMENT DIVISION (DEPT. 2), Highbury, London, N.5

Telephone: CANonbury 1234 (30 lines)

C.I.31



FOR MAXIMUM EFFICIENCY AND EASE OF MAINTENANCE

THE TYPE V.M.S. MULTI-CHANNEL V.H.F. RADIO SYSTEM.

This equipment, designed and manufactured by Automatic Telephone and Electric Co. Ltd., is used to provide radio links where the use of lines is either impracticable or too costly.

Operating on a frequency range of 156-200 Mc/s the equipment will give C.C.I.F. transmission standards on up to 36 simultaneous speech channels.

By the use of relay stations links may be operated over distances of several hundreds of miles.

Each panel comprises a number of sub-units, which are readily replaceable for maintenance purposes, no unsoldering being necessary. All equipment is robust and equally suitable for use in tropical or very cold climates.

This is only one of the many types of equipment manufactured by Automatic Telephone & Electric Co. Ltd. for radio telephone links. Write to us for details of equipment for your special needs. Our engineers conduct field surveys throughout the world to ascertain the most suitable equipment for particular purposes.

AUTOMATIC TELEPHONE & ELECTRIC CO. LTD.

(Radio and Transmission Division)

STROWGER HOUSE · ARUNDEL STREET · LONDON · W.C.2
Telephone: TEMple Bar 9262

Cablegrams: Strowgerex, London



A14162/R107

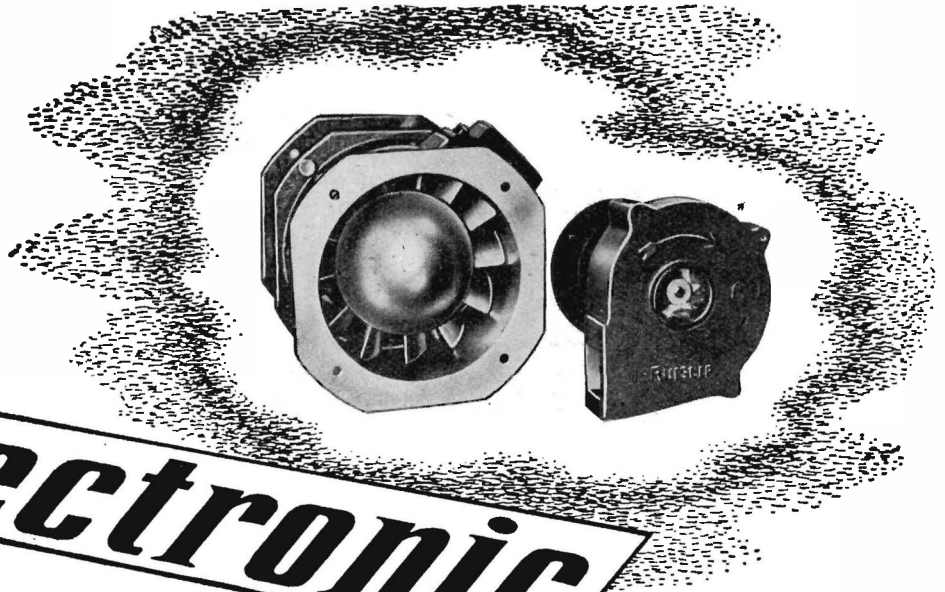

electronic COOLING

The wide range of blowers for force-cooling of valves and maintenance of desired temperature levels in electronic and general electrical apparatus is typical of the progress maintained by **ACI**. The illustration shows the smallest of the blowers (4" Axial Flow type and 2½" Centrifugal type), but our range covers duties from 5 c.f.m. up to many thousands of c.f.m. at pressures up to 45 or more inches w.g. These blowers are used in MARINE & AERODROME RADAR INSTALLATIONS, AIRCRAFT AUTOMATIC PILOTS, COMMUNICATION AND BROADCASTING STATIONS, R.F. HEATING EQUIPMENT, Etc. Let us know your application—we shall be pleased to put forward our proposals.



Complete
Air Treatment
Plant

AIR CONTROL INSTALLATIONS LTD.

Manchester

RUISLIP, MIDDX.

Glasgow

Telephone : Ruislip 4066 (8 lines)

Telegrams : Controlair, Ruislip

FOUR-WAY ELECTRONIC MIXER

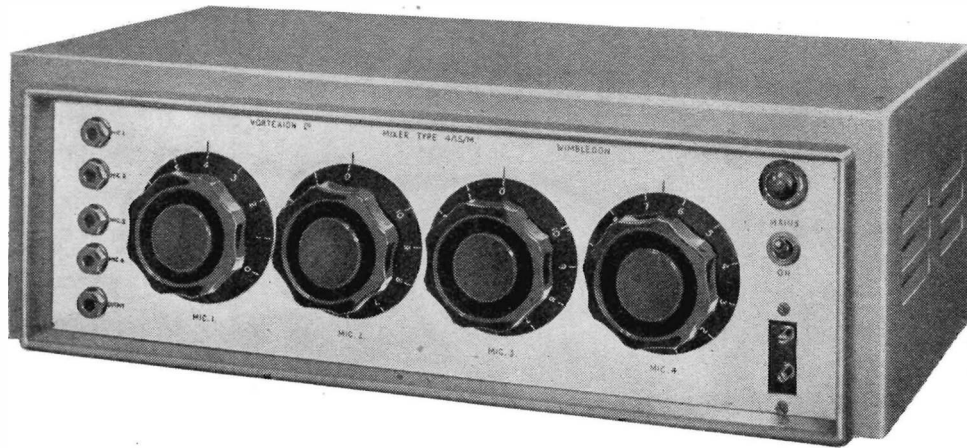

This unit has 4 built-in, balanced and screened microphone transformers, normally of 15-30 ohms impedance. It has 5 valves and selenium rectifier supplied by its own built-in screened power pack : consumption, 20 watts.

Suitable for recording and dubbing, or large P.A. installations, since it will drive up to six of our 50 watt amplifiers, whose base dimensions it matches. The standard model has an output impedance of 20,000 ohms or less, and any impedance can be supplied to order.

Manufactured by :

VORTEXION LIMITED

257-263, THE BROADWAY, WIMBLEDON,
LONDON, S.W.19

Telephones : LIBerty 2814 & 6242-3

Telegrams : "Vortexion, Wimble, London."

The obvious choice for
**RADIO RELAY & HIGH POWER
 PUBLIC ADDRESS
 EQUIPMENT**

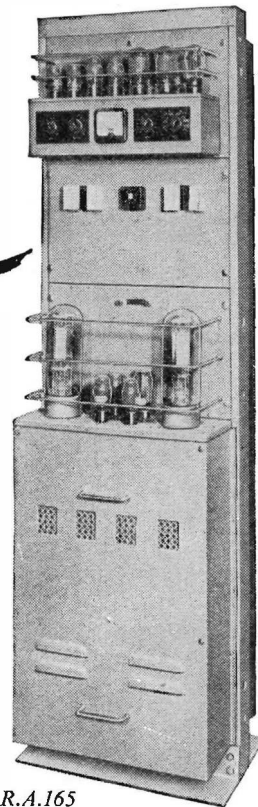
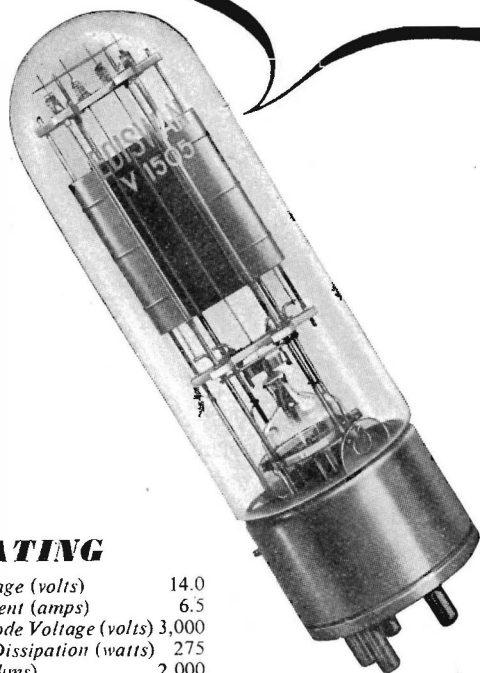

*E.M.I. R.A.165
 Relay Amplifier*

RATING

Filament Voltage (volts)	14.0
Filament Current (amps)	6.5
Maximum Anode Voltage (volts)	3,000
Max. Anode Dissipation (watts)	275
* Impedance (Ohms)	2,000
* Amplification Factor	16
* Mutual Conductance (mA/V)	7
Total emission approx. 4 amps.	
* At $V_a = 2,000v$	
$I_a = 150mA$	
Base: Special 4-pin.	

The long life and reliability of the Ediswan VI505 make it the obvious choice for Radio Relay and High Power Public Address Equipment such as the E.M.I. R.A.165 Relay Amplifier. In this equipment, a pair of Ediswan VI505's operating in push-pull provide a power output of 1,000 watts. The Ediswan VI505 is a radiation cooled triode with a directly heated thoriated tungsten filament and anode dissipation of 275 watts.

Full technical details and prices on request

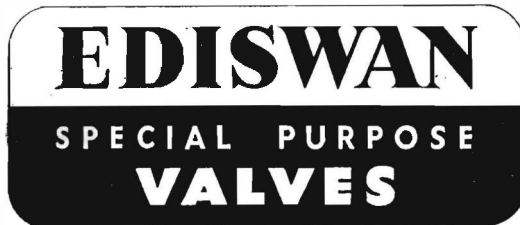

THE EDISON SWAN ELECTRIC COMPANY LTD., 155 CHARING CROSS ROAD, LONDON, W.C.2
Member of the A.E.I. Group of Companies

E.V.73



An Announcement. . .

DUREX ABRASIVES LTD. wish to announce that as from June 14th, 1951, the name of the Company has been changed and is now the MINNESOTA MINING & MANUFACTURING COMPANY LTD. Identification will be as before, except that the words "Scotch Boy" will be used instead of "DUREX" as a prefix to the name of the material, e.g., "Scotch Boy" Magnetic Recording Tape instead of "Durex" Magnetic Recording Tape.

Existing high standards in the quality of the products will be maintained, the change is in name only.

'SCOTCH BOY' Magnetic Recording TAPE



ANOTHER  PRODUCT

Manufactured by :—

MINNESOTA MINING & MANUFACTURING COMPANY LTD
167, STRAND, LONDON, W.C.2, and SLOUGH

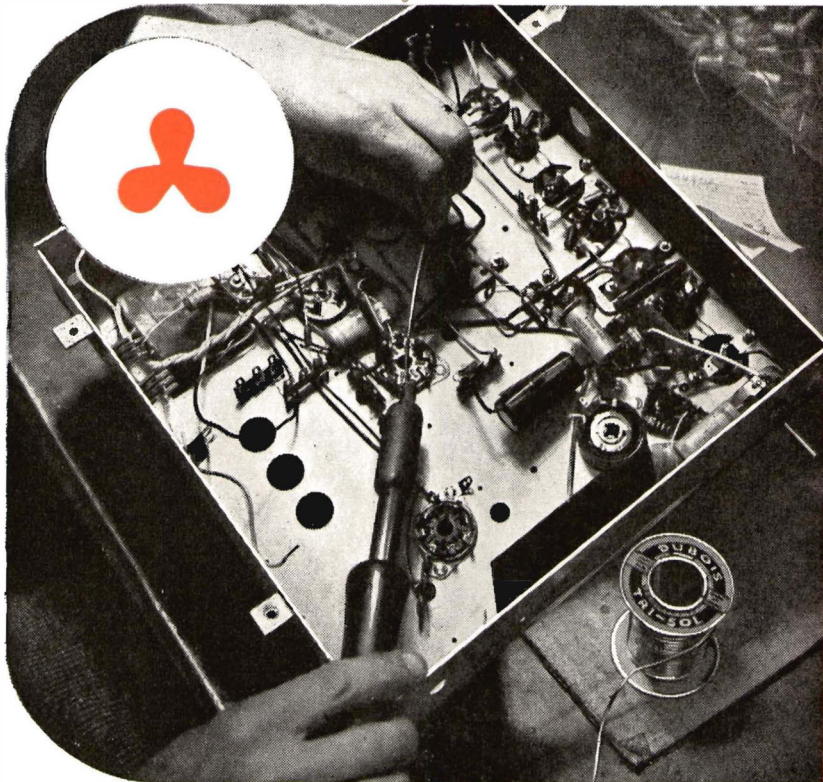

**FOR HIGH SPEED
PRECISION
SOLDERING USE
DU BOIS
TRI-SOL
Activated
RESIN CORED SOLDER**

Tri-Sol offers a consistently high standard of flux for high-speed precision soldering. Specially designed for radio, television and electrical assemblies. The core reduces the thickness of the solder wall, ensuring the correct proportion of flux.

Prov. Pat. 6654/50. Write for free sample and descriptive literature.

THE DU BOIS CO., LTD., 15 BRITANNIA ST., KING'S CROSS, LONDON, W.C.1

TERminus 6624

Photograph by courtesy of Raymond Electric Ltd.

Ceramic stand-off Insulators

by
U.I.C.

UNITED INSULATOR CO. LTD. OAKCROFT RD. TOLWORTH · SURBITON · SURREY
TELEPHONE: ELMBRIDGE 5241
CABLES: CALANEL, SURBITON

megohm meter

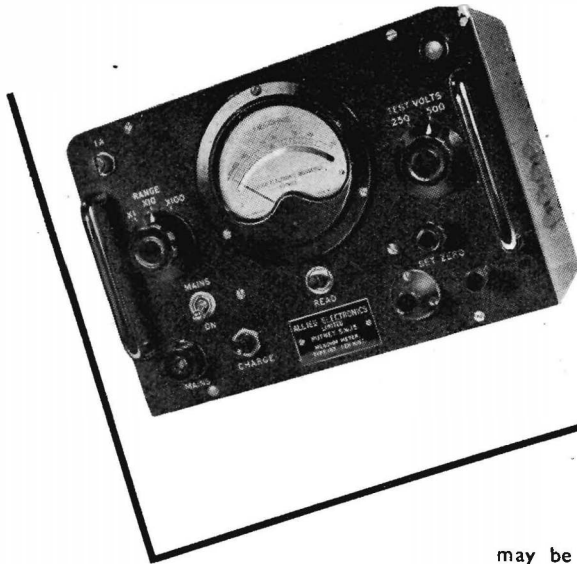

A compact and convenient instrument providing an instantaneous means of determining insulation resistance in workshop, laboratory or factory. A first-grade mirror scale meter reads directly in megohms from $20M\Omega$ to $50,000M\Omega$. The test voltage may be 250 or 500 volts and a "charge" button is provided for the rapid measurement of resistance associated with high capacitance. Power supply 200 - 250 volts A.C.

OTHER PRODUCTS INCLUDE: R.C. OSCILLATORS, SQUARE WAVE GENERATORS, MILLIVOLTERS, REGULATED POWER SUPPLY UNITS & INDUSTRIAL CONTROL GEAR
ILLUSTRATED CATALOGUE SENT ON REQUEST.

ALLIED ELECTRONICS LTD.

28, UPPER RICHMOND RD., PUTNEY, LONDON, S.W. 15.

TELEGRAMS: ALTRON PUT LONDON

TELEPHONE: VANDYKE 1856

QUALITY



RELIABILITY

*Transformers for the
Electronic Industry, Radio
& Research Establishments*

GARDNERS RADIO *Ltd*

SOMERFORD • CHRISTCHURCH • HANTS
TELEPHONE: CHRISTCHURCH 1025

Measurements from 30c/s to 10Mc/s

may be made with the

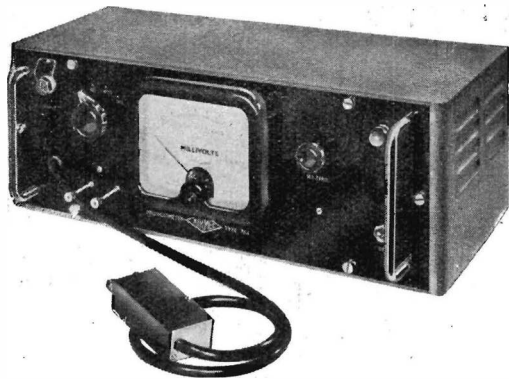

MILLIVOLTMETER

TYPE 784

THIS instrument consists of a high-impedance probe unit followed by a stable wide-band amplifier and diode voltmeter. Measurements may be made from 1 millivolt to 1 volt in the frequency range 30 c/s to 10 Mc/s. The provision of a low-impedance output enables the instrument to be used as a general-purpose amplifier in the frequency range 30 c/s to 15 Mc/s, or as an extremely sensitive high-impedance pre-amplifier for the Airmec Oscilloscope Type 723.

SPECIFICATION in use as

A MILLIVOLTMETER

Input Impedance : 1 Megohm in parallel with 14 pF.
Voltage Ranges : 0-10, 0-100, 0-1,000 millivolts.
Accuracy : 30 c/s-5 Mc/s, $\pm 5\%$ of F.S.D.
5 Mc/s-10 Mc/s, $\pm 10\%$ of F.S.D.

A WIDE-BAND AMPLIFIER

Output Impedance 200 hms.
Voltage Gain : 30 d.B.
Frequency Response : Less than 6 db down at 15 Mc/s.

A PRE-AMPLIFIER FOR THE AIRMEC OSCILLOSCOPE, TYPE 723

Sensitivity : 2 millivolts R.M.S. per centimetre at an E.H.T. voltage of 2 kV.
Frequency Response : ± 2 db from 30 c/s-5 Mc/s.

AIRMEC
LABORATORIES, LTD.

HIGH WYCOMBE - BUCKINGHAMSHIRE - ENGLAND

Telephone : High Wycombe 2060

Cables : Airmec High Wycombe.

Austinlite 'Fifty'

50 amps at 450 volts A.C. (slow break). 20 amps at 250 volts D.C. (quick break). Also available with 6 or 8-way mechanism for tapping etc.

Austinlite 'Thirty'

30 amps at 250 volts A.C. (slow break). 15 amps at 440 volts A.C. (slow break). 5 amps at 230 volts D.C.

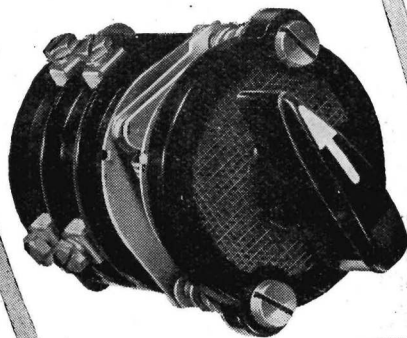

Austinlite switches are built for heavy duty.

Their intelligent use for all forms of motor control including reversing, star delta starting and dynamic braking can save the expense of separate contactors or relays.

For heater selection, on load transformer tap changing, or change-over switching, they are unrivalled. Why not

send us details of *your* switching problem?

Cut your control gear costs

Austinlite switches are used and specified by: The Admiralty; British Electricity Authority; The Air Ministry; British Broadcasting Corporation; General Post Office; Crown Agents for the Colonies; National Physical Laboratory; Royal National Lifeboat Institution and most of the leading electrical manufacturers in Great Britain.

A *Chance* PRODUCT

AUSTINLITE LIMITED (A subsidiary of Chance Brothers Limited)
Dept. A.5, Lighthouse Works, Smethwick 40, Birmingham. Tel: West Bromwich 1824

FERROXCUBE

FERROMAGNETIC FERRITE

FOR TELEVISION

THE improvement in television components, with their smaller size and greater efficiency, is largely due to Ferroxcube, the new Mullard magnetic core material. The uses of Mullard Ferroxcube in the production of TV components fall into these three main groups:

LINE OUTPUT TRANSFORMER CORES

Since the advent of wide-angle television tubes, with the accompanying demand for increased E.H.T. supplies, the need for line output transformers of the highest possible efficiency has been greater than ever. Mullard Ferroxcube, with its low iron losses, completely fulfils this need — also facilitating the assembly of small, compact transformer units by means of solid, non-laminated U-shape cores.

DEFLECTION COIL YOKES

Mullard Ferroxcube cores in ring form are ideal for producing the magnetic circuit around deflection coils. Used in this way, Mullard Ferroxcube makes possible the construction of efficient deflector coils with a high Q factor. In order to simplify assembly problems, these ring cores are supplied either in the form of a complete circle, as two semi-circles, or as castellated yokes.

LINEARITY AND PICTURE WIDTH CONTROLS

Mullard Ferroxcube can very conveniently be extruded into rods and tubes. In this form it is ideal for use in linearity and picture width controls, providing a smooth control in a compact assembly.

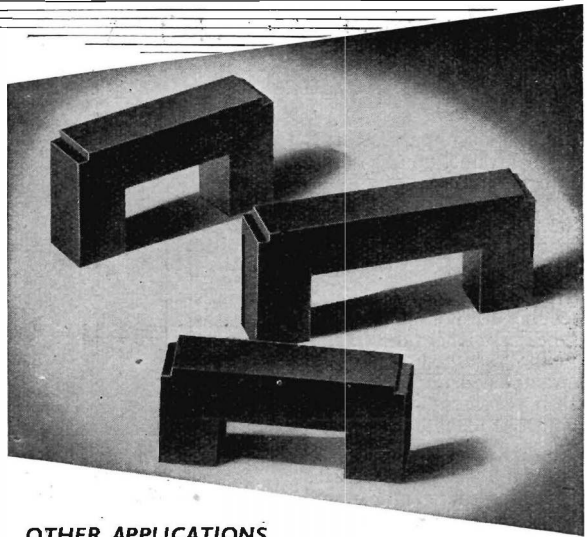

OTHER APPLICATIONS

In addition to its uses in television receivers, Mullard Ferroxcube is also being widely employed in line communications, radar, and other specialised electronic equipments. The purposes for which it is already being most successfully applied in such equipments include filter networks, wide band transformers, magnetic amplifiers, and pulse transformers.



PLEASE WRITE FOR FULL DETAILS

Mullard FERROXCUBE

FERROMAGNETIC FERRITE

MULLARD LIMITED · CENTURY HOUSE · SHAFTESBURY AVENUE · LONDON · W.C.2.
(MP376)

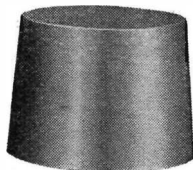
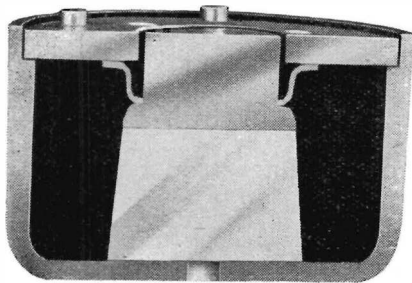

PERMANENT MAGNETS

A COMPLETE SERVICE —
ADVISORY AND SUPPLY —
FOR SPECIALISED INDUSTRIES

The most efficient method of using the high energy Permanent Magnet materials in the manufacture of Loud Speakers is shown in this illustration.



DARWINS LTD

TINSLEY · SHEFFIELD · 9

D27/A.

THE IMPORTANCE OF PULP . . .

*First of a series
telling the story of Goodmans Loudspeakers*

Pulp is very important. It is a key stage in the production of a component which forms a vital part of a loudspeaker—the cone. Cone, and hence speaker quality, are dependent on the pulp, and its manufacture is a rigidly controlled process.

The “beaterman” in our illustration is feeding raw pulp-board into the “beater,” where the cellulose fibres are first “brushed out”—stroked and straightened under a precision roller—then “beaten”—cut to an accurately controlled length.

At this stage the pulp is impregnated with the chemicals which render the cones proof against humid conditions and the attacks of termites and bacteria.

The pulp is then ready to be formed into “raw” cones or “felts,” the second stage of its progress from crude paper millboard to sensitive speaker diaphragm: the subject of the next announcement in this series.

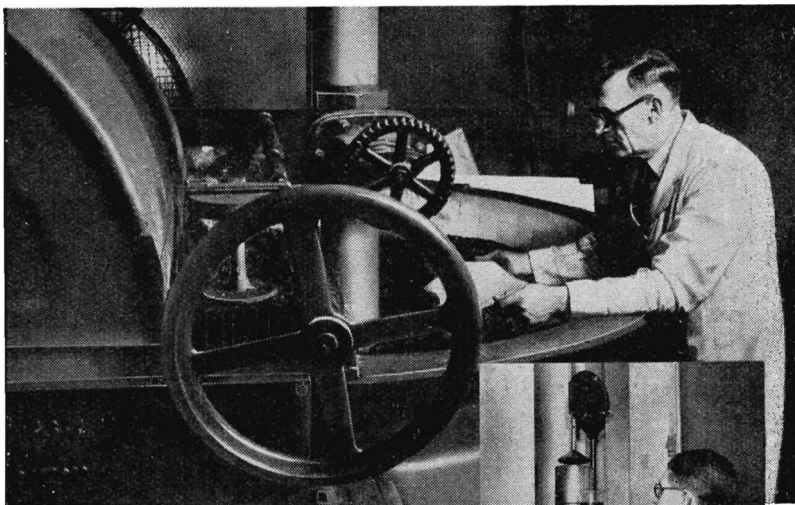

Testing at every stage is the rule at Goodmans. With the Schopper-Reigler apparatus (right) our chemist makes frequent tests for pulp consistency.

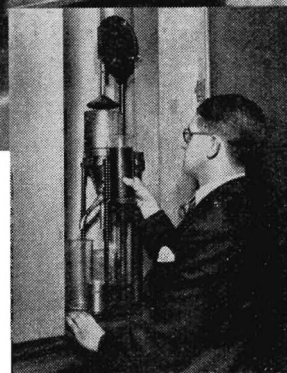

AUDIOM 60 12" 15w P.M. Loudspeaker

Limited supplies of this speaker are now becoming available again on the home market. If you are unable to obtain supplies, let us know your dealer's name.



GOODMANS

GOODMANS INDUSTRIES LIMITED, Axiom Works, Wembley, Middx. Telephone: WEMbley 1200

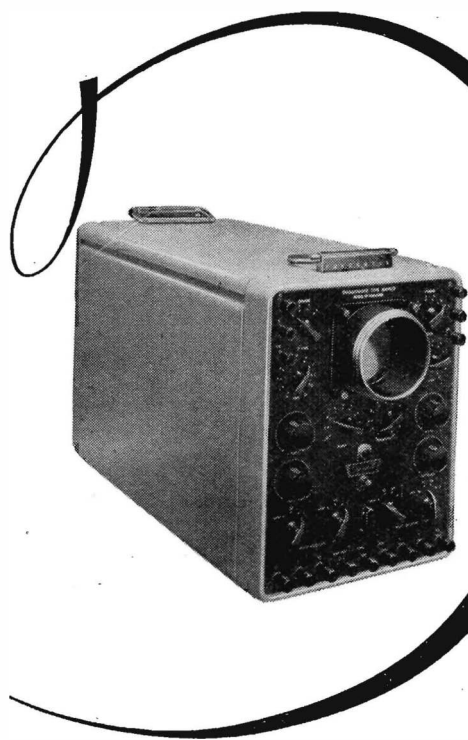

For critical analysis or routine production

The 1684D/2 Cathode Ray Oscilloscope has been designed to meet these diverse requirements of laboratory, field and production units. Symmetrical d.c. circuiting is employed throughout, the amplifiers having a high and uniform sensitivity from zero frequency up to 3 Mc/s.

Furzehill

FURZEHILL LABORATORIES LIMITED
BOREHAM WOOD, HERTS. TEL: ELStree 3940

The Murphy TPG11

is not our only line!



F. LIVINGSTON HOGG

LIVINGSTON LABORATORIES,
RETCAR STREET,

DARTMOUTH PARK HILL, LONDON, N.19.

Telephone: ARCHWAY 2442.

IN the test rooms, research and development laboratories and workshops of almost every Radio, Television and Radar Manufacturer in the country, you will find hundreds of new and renovated electronic instruments, supplied by us.

The demand for this side of our work has so far, always exceeded our capacity, so we have not hitherto advertised it. Now, we have at last obtained extensive new premises near Archway Tube Station. When alterations are completed, we shall be able to welcome old and new friends to a unique establishment, with comprehensive laboratory facilities and large stocks of new and renovated instruments of all good makes.

OUR POLICY: *Technical accuracy is vital!
Advice must be impartial!*

Specialists in instruments for the Communications Industry

ACCURACY IS NOT ENOUGH . . .

The most accurate measuring instruments in the world are only of use if they can be read easily. A feature of the range of Pullin Rectangular instruments is the extreme legibility of their scales.

Available in all the standard ranges in sizes 3", 3½" and 6". Let us know your requirements and we shall be pleased to make recommendations regarding suitable instruments.

PULLIN RECTANGULAR INSTRUMENTS

Measuring Instruments (Pullin) Ltd., Electrin Works, Winchester St., London. W.3. Phone: ACOrn 4651

ALL-POWER

REGULATED POWER SUPPLIES

Semi-standard designs are available covering output voltages from 0.1 to 2,000 volts and output currents from 1mA to 10 amps.

Special Units can be made to any Specification, and although the demand for our products is continually increasing we can still offer reasonably prompt delivery.



ALL-POWER TRANSFORMERS LTD.

CHERTSEY ROAD, BYFLEET, SURREY.

TEL.: BYFLEET 3224.

GRAVINER RESETTING FIRE DETECTOR uses MUREX Sintered Permanent MAGNETS

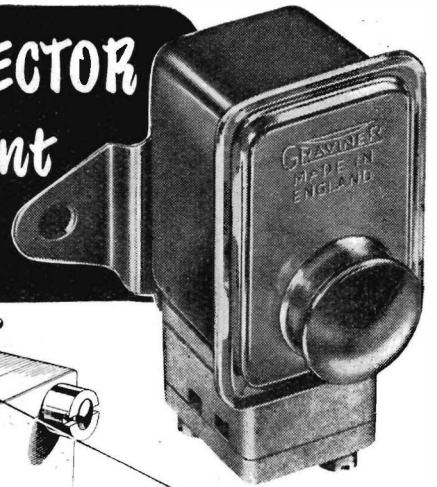
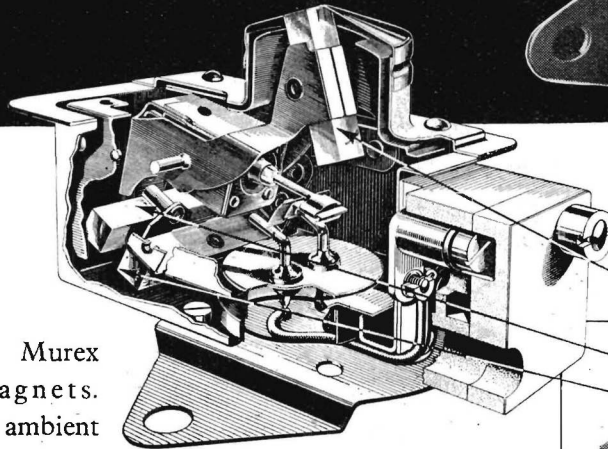

Another application of Murex permanent sintered magnets. Magnet A is subjected to ambient temperatures of 170°C (Mk.1) or 290°C (Mk.2). Magnets B & C are working in repulsion and open circuit. Such arduous conditions call for high magnetic efficiency and stability.

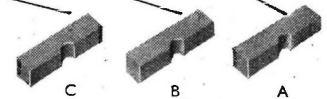

Actual size of Magnets

MUREX LIMITED (Powder Metallurgy Division) Rainham · Essex Telephone: Rainham, Essex, 240
LONDON SALES OFFICE: CENTRAL HOUSE, UPPER WOBURN PLACE, W.C.1. Telephone: EUSon 8265

Mullard GENERAL PURPOSE OSCILLOGRAPH TYPE E805

This Cathode Ray Oscillograph is for general purposes. But it incorporates many features not normally found in such instruments. It covers a very wide range of frequency, including the whole frequency spectrum used in television. And it's equally well suited for research work, production testing or transmission monitoring. Many of Industry's high frequency problems can be solved with this oscillograph's aid — particularly those problems of motor-car ignition, flash-over on insulators, discharge at high voltages, etc.

- 3½" cathode ray tube with 1,250 volt final anode potential.
- Beam modulation. External blanking of beam for timing purposes and eliminating retrace.
- Beam suppression prevents "fogging" of film when camera shutter is open.
- Single stroke operation for non-recurrent phenomena or photographic recording.
- Calibrated step-type input attenuator with coarse and fine adjustment.



The Mullard Cathode Ray Oscillograph, type E.805. Dimensions: Height 14"; Width 9"; Length 15½". Please write for detailed information.

SPECIFICATION

Amplifier. Gain 1,400 or fmV rms/cm. Frequency range 2 c/s-2 mc/s. 3 dB loss.

Attenuator. Stepped 5-10-20-35 mV cm. Multiplier x 1, x 10, x 100 x 1000. Maximum input 250 V. rms.

Time Base. 5 c/s-150 Kc/s in 10 steps with continuous variation between steps.

(MI.358)

NORTHERN AGENT:
F. C. Robinson & Partners,
Ltd., 287, Deansgate,
Manchester, 3

MIDLAND AGENT:
Hadley Sound Equip-
ments, 72, Cape Hill,
Smethwick.
Smethwick 0977

SCOTTISH AGENT:
Land, Speight & Co. Ltd.,
73, Robertson Street
Glasgow, C.2.

Mullard Ltd., Equipment Division, Century House,
Shaftesbury Avenue, London, W.C.2. Telephone: Gerrard 7777

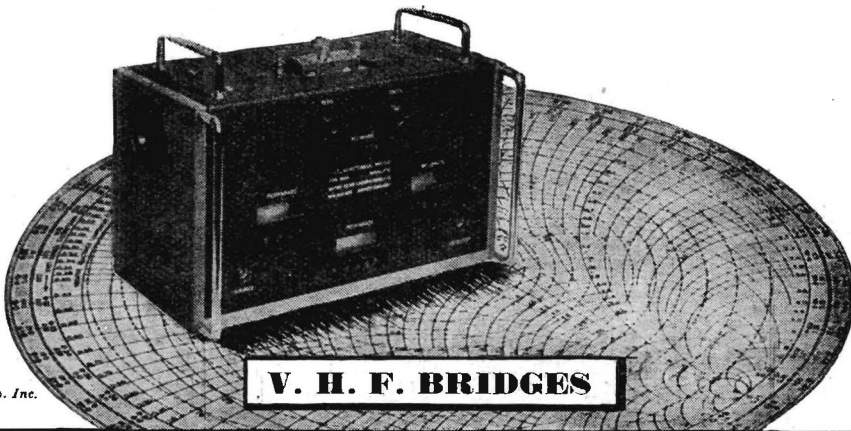

Diagram by courtesy of
McGraw Hill Pub'g. Co. Inc.

V. H. F. BRIDGES

for balanced and unbalanced measurement at frequencies between 1 Mc/s and 250 Mc/s.

Wayne  Kerr

THE WAYNE KERR LABORATORIES LIMITED, NEW MALDEN, SURREY. PHONE: MALDEN 2202

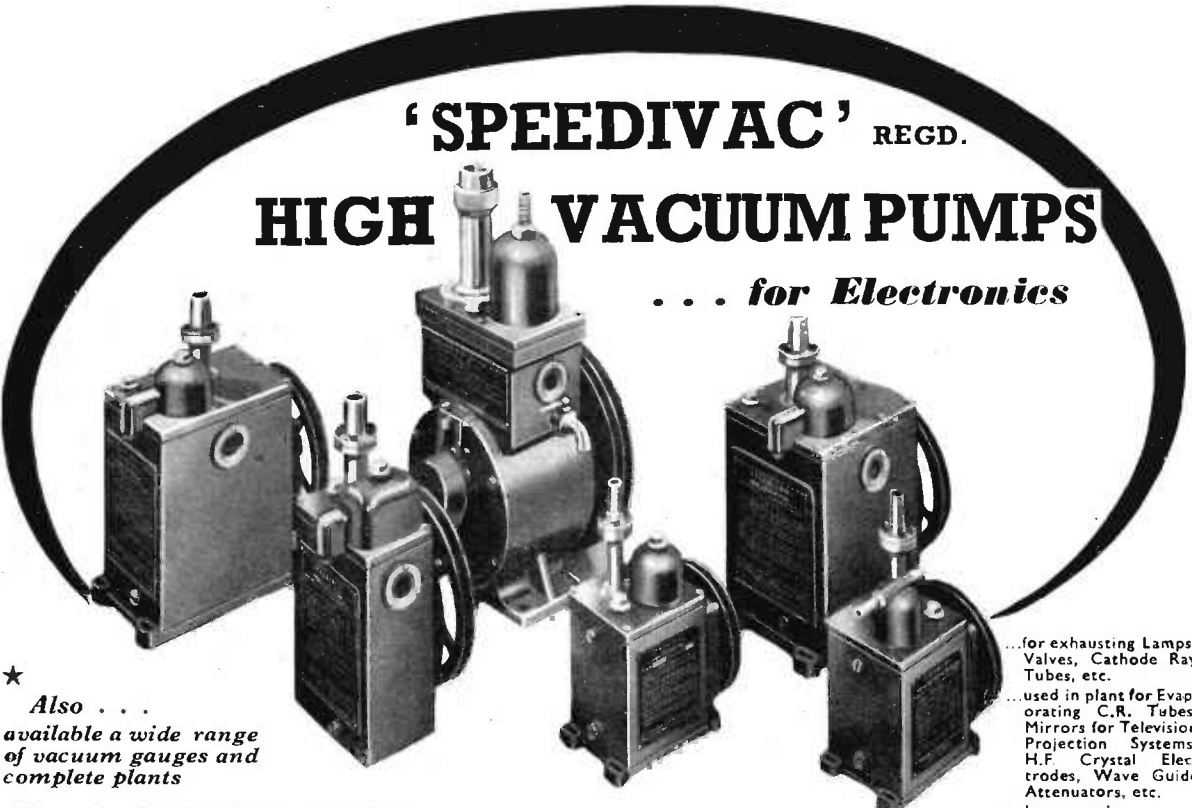

★ Also ... available a wide range of vacuum gauges and complete plants

...for exhausting Lamps, Valves, Cathode Ray Tubes, etc.
 ...used in plant for Evaporating C.R. Tubes, Mirrors for Television Projection Systems, H.F. Crystal Electrodes, Wave Guide Attenuators, etc.
 ...Impregnation

W. EDWARDS ... *For better vacuum service*
 & CO. (LONDON) LTD. LOWER SYDENHAM · LONDON · S.E.26 30 YEARS VACUUM EXPERIENCE
 Telephone: SYDenham 7026 (8 lines) Telegrams: Edcovac, Souphone, London.

PRESSINGS & STAMPINGS

BY
W-B-G
 THE FIRM WHO MAKES ITS OWN MATERIALS



WRIGHT, BINDLEY & GELL LIMITED
 TELEPHONE PERCY ROAD, GREET TELEGRAMS:
 VICTORIA 2295/6/7 (PBX) BIRMINGHAM, II. BINDLEY B'HAM, II.

COMMUNICATIONS

Redifon Radio

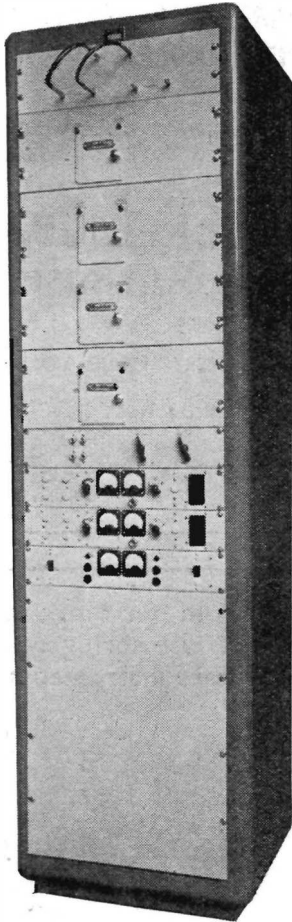

The Redifon R93 fixed frequency, high stability receiver is particularly suitable for monitoring, diversity reception or frequency shift operation. A typical application is this twin-channel, dual diversity, frequency shift radio teleprinter terminal. Multi-channel diversity or non-diversity racks can also be provided which incorporate a multi-receiver coupling unit (Redifon Type MCU.1) allowing up to eight receivers to be fed from a single aerial.

Recommendations for complete receiving stations employing these and other systems will gladly be submitted on request.

REDIFON LIMITED
BROOMHILL ROAD, WANDSWORTH,
LONDON, S.W.18

Designers and Manufacturers of Radio Communications and Electronic Equipment.



AND THE

PREVENTION

OF

STATIC

A thin, dry graphite coating, formed with a dispersion of 'dag' colloidal graphite on "plastics" and other materials, prevents electrostatic charges accumulating on:—

INSTRUMENT WINDOWS, FAST TRAVELLING CONVEYOR and DRIVING BELTS, INSULATORS and AIRCRAFT SURFACES

Applied by brush, spray or dip, 'dag' colloidal graphite may be used as: Electrodes in Cathode Ray Tubes, Geiger counters, Light cells, Radiation meters, Screens on T.V. cabinets to suppress E.H.T. radiation, Resistors—printed and conventional types.

POST THIS COUPON TODAY

TO: **ACHESON COLLOIDS LIMITED**
18 PALL MALL, LONDON, S.W.1

Please send me additional information on the above or other applications for 'dag' colloidal graphite in the field of electronics.

NAME

ADDRESS

.....D/18

ACHESON COLLOIDS LIMITED
18 · PALL MALL · LONDON · S.W.1





STOCKISTS OF
BX POLYSTYRENE

No other rigid insulating material has such a low power factor.
Power factor (60-10⁶ c.p.s.) 0.0001-0.0006
Permittivity (60-10⁶ c.p.s.) 2.6-2.7
Dielectric Strength (volts/mil.) 500-750
Volume Resistivity (ohm-cm.) 10¹⁷-10¹⁹
Specific Gravity 1.05-1.07
Water Absorption, Nil

SHEETS

28" x 20" Thickness $\frac{1}{8}$ ", $\frac{1}{4}$ ", $\frac{3}{8}$ ", $\frac{1}{2}$ ", $\frac{3}{4}$ ", 1 ", $1\frac{1}{2}$ "
22" x 18" Thickness $\frac{1}{8}$ ", $\frac{1}{4}$ ", $\frac{3}{8}$ ", $\frac{1}{2}$ ", $\frac{3}{4}$ ", 1 ", $1\frac{1}{2}$ "

RODS

Standard 6 ft. lengths. Diameters $\frac{1}{8}$ ", $\frac{3}{16}$ ", $\frac{1}{4}$ ", $\frac{5}{16}$ ", $\frac{3}{8}$ ", $\frac{1}{2}$ ", 1 ", $1\frac{1}{2}$ " and $1\frac{3}{4}$ "

POLYSTYRENE FOR THE ELECTRICAL AND RADIO MANUFACTURER

Information and guidance on manipulation, machining, and cementing, available on request

MILTOID LTD.

34/36 Royal College Street, London, N.W.1
Phone : EUSon 6467. Grams : Celudol, Norwest, London

T.A. 4358

COPPER, BRASS, BRONZE, ALUMINIUM, LIGHT ALLOYS

3,000 Standard Stock Sizes

of

ROD, BAR, STRIP, SHEET, TUBE, CHANNEL, ANGLE, TEE, WIRE

"No Quantity too Small"

H. ROLLET & Co. LTD.

6 CHESHAM PLACE, LONDON, S.W.1

SLOne 3463.

WORKS : 36, ROSEBERY AVENUE, LONDON, E.C.1

BRANCHES :

Kirkby Trading Estate,
East Lancashire Road,
LIVERPOOL.
Simonswood 3271.

55, Market Street,
MANCHESTER.
Blackfriars 2854

ALWAYS "FIT"



CASTORS

Internal expanding braked types and spring equalising types available. Ask for brochure pages and 27, 37.

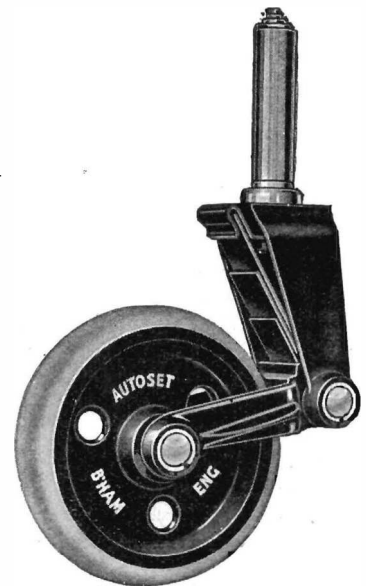
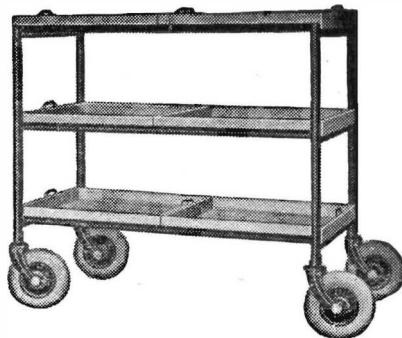

Select your castors from our range of over 6000 types and sizes. Use spring types for carriage of delicate instruments.

Engineers, Patentees and Sole Manufacturers

AUTOSET (PRODUCTION) LTD.,

DEPT. O, STOUR ST., BIRMINGHAM, 18. Phone EDG. 1143/4. Est. over 30 years.

PLEASE MENTION "ELECTRONIC ENGINEERING"



*Pioneers and specialists
in Small Valves*

SUBMINIATURES
MINIATURES
MIDGETS
GAS TRIODES
ELECTROMETERS
COLD CATHODE
TUBES

HIVAC LTD

GREENHILL CRESCENT, HARROW-ON-THE-HILL,
MIDDLESEX.

Telephone: HARrow 2655

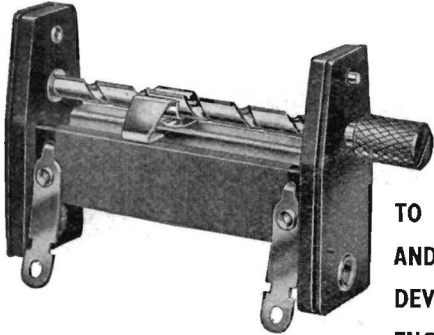

TO RADIO
AND T/V
DEVELOPMENT
ENGINEERS

This midget pre-set variable resistor with new double-slider gives greater stability and makes accurate adjustment easier. Designed for panel or chassis mounting: available in any value from 10 to 25,000 ohms.



Charfleet Industrial Estate, Canvey Island, Essex. Phone: Canvey 691

TUNGSTEN WELDING ELECTRODES FOR INERT GAS ARC WELDING



Molybdenum
Tubes and other
Molybdenum Com-
ponents.
Tungsten Rods and three-
piece Lead Wires for tungsten
to glass seals.
X-ray Targets with or without
cast-on copper body.
Rotating Anodes.
Tungsten Contact Rivets and Screws.

ELECTRO-ALLOYS Ltd.

12, BRUNEL RD., LONDON, W.3.

Makers of TUNGSTEN and MOLYBDENUM Products

"VARIAC"

Regd. Trade Mark

Infinitely Variable VOLTAGE REGULATING TRANSFORMER

Smooth Control

Linear scale,
various mark-
ings.

115 or 230 volts
service or others
if required.

Special types
for 500 cycle or
2,000 cycle, etc.,
can be supplied.

Low tempera-
ture rise.

Bench or panel
type mounting,
reversible shaft.

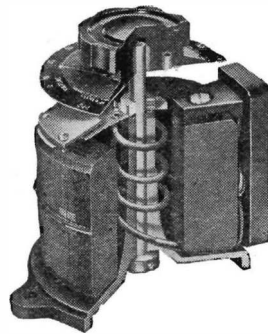

Reasonable
overload capa-
city.

Output in-
dependent of
load.

Single or duplex
voltage outputs.
(Type 100 RM/
2B).

Supplied with or
without screen.

Ring-type
laminated core.

The 'sectional-
ised' illustration
shows Types 200
(580 and 860 va).
Larger types are
made-up to 7
Kva.

Write for Catalogue V549 for complete data

CLAUDE LYONS LTD.

ELECTRICAL & RADIO LABORATORY APPARATUS, ETC.

180 Tottenham Court Road, London, W.1, and
76 Oldhall Street, Liverpool 3, Lancs.



Antenna Theory and Design

(2 vols.)

By H. Paul Williams, Ph.D., A.M.I.E.E., Sen.M.I.R.E. This important two-volume work gives a complete account of the theoretical basis of antenna design followed by comprehensive guidance on the practical aspects of this work. Profusely illustrated. Vol. I (Foundations of Antenna Theory), 142 pages. 21/- net. Vol. II (The Electrical Design of Antennae), 522 pages. 63/- net.

"A most comprehensive treatment of the theory and practice . . . can be confidently recommended to all engineers concerned with aerial design, no matter in what part of the frequency spectrum."—ELECTRONIC ENGINEERING.

Pitman,

Parker Street, Kingsway, London, W.C.2



COMPOUND FILLED TRANSFORMERS & CHOKES

for

UTMOST RELIABILITY

Woden Compound Filled transformers have been developed for use in exacting industrial and climatic conditions and have the following features :—



- Complete moisture-proof filling compound
- Universal fixing for above or below chassis wiring
- Constant fixing centres and overall size
- Occupy minimum space and ensure clean and compact layout

Send for latest catalogue

WODEN TRANSFORMER CO., LTD.,
MOXLEY ROAD, BILSTON, STAFFS.

J.T.L.

SHORTAGE OF ELECTRONIC TECHNOLOGISTS

The demand of Industry and the Ministries for our trained students is still far greater than we can supply. For top-grade technologists we offer :

THREE-YEAR COURSE IN TELECOMMUNICATION ENGINEERING (including one year's Factory attachment)

Next Course commences 25th August.

Write for **FREE BROCHURES** giving details of the above and other day-time attendance courses.

E.M.I. INSTITUTES—the only college which is part of a great industry.

E.M.I. INSTITUTES

(DEPT. 11E), 10, PEMBRIDGE SQUARE, LONDON, W.2. TEL. BAYSWATER 5131/2

Associated with "H.M.V." MARCONIPHONE COLUMBIA ETC.

I.43

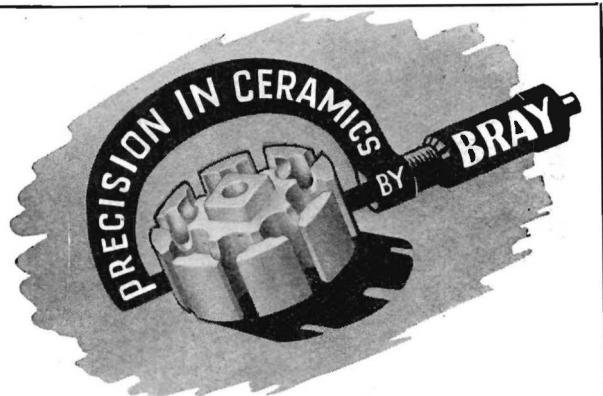

Quantity production of small automatically made pieces in Steatite, Porcelain, and Rutile materials for electric cooking and heating equipment, and telecommunication apparatus.

BRAY



GEO. BRAY & CO. LTD., Leicester Place, Leeds 2.
Tel.: 20981/8. Grams.: "Bray, Leeds 2"

B.P.L. TEST SETS

B.P.L. D.C. TEST SET - £7 5 0

B.P.L. UNIVERSAL TEST SETS
£8 17 6

B.P.L. UNIVERSAL TEST SETS
20,000 Ω/v £11 10 0

B.P.L. SUPER RANGER £19 19 0

B.P.L. SUPER RANGER 20,000 Ω/v
£22 15 0

All prices subject to trade discount.
Available for immediate delivery
from our stockists, M.R. Supplies
Ltd., 68, New Oxford Street, W.C.1.
or write to :

BRITISH PHYSICAL LABORATORIES
HOUSEBOAT WORKS, RADLETT, HERTS.

Telephone : Radlett 5674/5/6



*... It's surprising
where you find them*

The list of "Castle" Components knows no limit. Whatever your needs may be — in Repetition work in all Metals — we can meet them exactly. Machining and Light Assemblies, too. *Send for brochure.*



THE
CASTLE ENGINEERING
COMPANY (NOTTINGHAM) LIMITED

HASLAM STREET · CASTLE  BOULEVARD · NOTTINGHAM

6133B

**DONOVAN
ACCESSORIES**
for the
**ELECTRONIC
APPARATUS
MANUFACTURER**

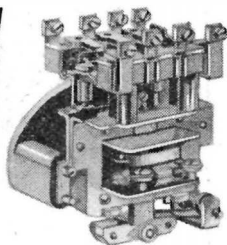

Type A.11 A.C. POWER
RELAY—4-pole with N.O.
or N.C. contacts.

**TYPE J.96
TERMINAL BLOCKS**

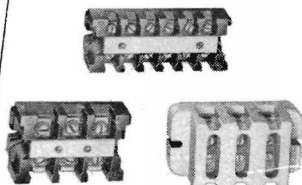

Made in 15, 30 and
60 amp. sizes.

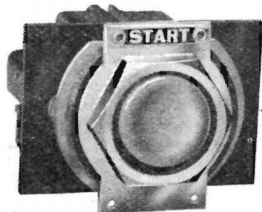

Type C.30 PUSH BUTTON UNIT
arranged for mounting on
customers' own cover plate.

THE DONOVAN ELECTRICAL CO. LTD.
Safuse Works · Stechford · Birmingham, 9.

LUMINESCENT MATERIALS

FOR

ELECTRIC DISCHARGE LAMPS

CATHODE RAY TUBES

X-RAY SCREENS

INSTRUMENT DIALS

DECORATIVE DISPLAYS

**SPECIAL PHOSPHORS MADE TO
CUSTOMERS' SPECIFICATIONS**

★ ★ ★

DERBY & COMPANY LTD.

Offices:

11-12 St. Swithin's Lane, London, E.C.4.

Telephone: AVENUE 5272.

Telegrams: PLATIVET, London

Works:

Millmarsh Lane, Brimsdown, Middx HOWard 2208

SUCCESS?

The demand for qualified technicians to fill well-paid industrial posts grows daily. An E.M.I. course of training is your quickest way to a key position. Our Home Study courses cover all the subjects listed below. As part of the great E.M.I. Group ("H.M.V.", Marconi, etc.), we have first-hand knowledge of the technical training required in modern industry. No other college can offer you such a practical background of industrial experience.

START
HERE

— POST THIS COUPON NOW —

E.M.I. INSTITUTES, Postal Division, Dept. 11, 43, Grove Park Rd., Chiswick, London, W.4. Please send, without obligation, your FREE BROCHURE. I have marked the subjects which interest me.

Mech. Eng. Elect. Eng. Draughtsmanship Radio Television
 Production Eng. Auto. Eng. Aeronautical Eng. Civil Service
 General Cert. of Education (Metric). Also Courses for A.M.I. Mech.E., A.M.I.C.E., A.M.Brit.I.R.E. A.F.R.Ae.S., CITY and GUILDS EXAMS, in Mech. Eng., Elect. Eng., Telecommunications, etc.

NAME

ADDRESS

E.M.I. INSTITUTES — The College backed by an Industry 1.39

Hifi
REGD. TRADE MARK

HIFI LTD., 150, HIGH STREET, LYE, STOURBRIDGE, WORCS. Telephone: LYE 261

BRADMATIC LTD.

Offer the BRADMASTER Model 5 Tape Desk

- Built to professional standards.
- Two speeds—3½ and 7½ inches per second.
- Easily adjusted for single or twin track recording.
- Fast wind and rewind—full reel rewound in 1½ minutes.
- Heavy alloy flywheel. Freedom from "wow" and "flutter"
- Double servo brakes on each hub.
- Push-button control.
- Three heavy duty motors.
- Three shielded Bradmatic heads.
- Size: 13½ in. by 15½ in. by 6½ in. deep.

PRICE: (Fitted with 5RP heads) £41 0 0
 (Fitted with 6RP heads) £42 0 0

Hi-fidelity Magnetic Sound Heads:	£	s.	d.
type 5RP (record/play)	3	5	0
type 5E (erase)	3	5	0
Super fidelity magnetic sound head:			
type 6RP (record/play head)	3	15	0
Composite Screening Cans (steel and mumetal)	4	6	
Oscillator, Coils type 1B	9	0	
Plate Coils, type 1B	9	0	
Tape on 7-inch reels, 1,200 ft.:			
Emitape type 65 (low coercivity)	1	15	0
Emitape type H60 (high coercivity)	1	15	0
Scotch Boy (Durex)	1	15	0
G.E.C. type A	1	10	0

Amplifiers and Microphones, etc., supplied

Trade Supplied. Send for Lists to the Sole Manufacturers:

BRADMATIC LIMITED
 STATION ROAD • ASTON • BIRMINGHAM 6
 Phone: EAST 0574. Grams: Bradmatic, Birmingham.

'Radiospares' Quality Parts

The Service Engineer's First Choice

Technical Excellence

combines with beauty and soundness of DESIGN in the

OXLEY

DIFFERENTIAL AIR DIELECTRIC TRIMMER

★ Width: 16.6 mm Length: 26 mm
 Height: 1.5 to 8pP—8 mm
 1.8 to 20pP—10.3 mm
 2 to 20pP—11.5 mm
 2 to 32pP—12.6 mm

Low: Straight line capacity
 Power Factor: Less than .001
 Insulation: Over 2,000 megohms
 Voltage: 500 D.C.

OXLEY DEVELOPMENTS CO., LTD.,
 ULVERSTON, N. LANCS. TEL. ULVERSTON 3306

"SPEARETTE"

MINIATURE VALVE RETAINING CLIPS

Types available for B7G and B9A base Valves

SPEAR ENGINEERING Co. Ltd.
 WARRLINGHAM, SURREY
 Phone: Upper Warrlingham, 2774

TAMSA

REGISTERED TRADE MARK

Tape and Wire Recording

We supply ALL RECORDING COMPONENTS—Write for Latest Price List of TAPE MECHANISMS, TAPES, WIRES and SPOOLS—HEADS, AMPLIFIERS, OSCILLATOR COILS and UNITS

NOW AVAILABLE—The NEW TYPE H60 HIGH COERCIVITY EMITAPE. TOPHET M, High Quality Recording Wire
HIGH ACCURACY COUNTING DEVICES
 Development of electronic applications to industry

Manufactured by

Telephone: NORTHERN 2084

Telegrams: Audigraph, Birmingham

Dept. MR7, Gt. Hampton Street, Hockley, Birmingham, 18

WILKINSON'S OF CROYDON

KLAXON GEARED MOTORS. No. 1K55B3-W7. 230V. A.C. Split Phase Induction Type, with a torque of 15 lb. in. R.P.M. 175. £10 each.

KLAXON CAPACITOR MOTOR. No. EM5CB2. 220/240V. 1/40 h.p., with Condenser. 55/- each.

BATTERY CHARGERS. Westalite. Input 100/250V. A.C. Output 12V 16 amps. D.C. Fully variable fused and metered. £15. 15s. each, carriage paid.

BATTERY CHARGER. Input 230V. A.C. Input 6 or 12V. 4 amps. In black crackle case with fuses, switch and meter. £5. 5s., carriage paid.

ACFIL PUMPS. These pumps enable you to fill all accumulators on the bench with the carboy at floor level. 30/- (post 1/6).

SLYDLOK FUSES. 100 amp. Type G99 M.M. Complete with studs, nuts and washers. Brand new. 13/6 each net. Large stocks held. ; also other sizes.

3/40 ENAM Copper Wire, single rayon covered, 20/- per lb.

CO-AXIAL Elbow Sockets, 10H/701 and 10H/3911 ; also Plugs 10H/528. 8/- doz. Large quantities available at reduced rates.

BC221. Frequency Meter 125 to 20,000k/cs New. £35.

RESISTORS, WIRE WOUND and carbon types. Large stocks held of most values.

TELEGRAPH RELAYS. No. 4121C. 40/- each. Also Type 3000 and Siemens High-speed, etc.

ROTARY SWITCHES. Diamond H. Double Pole Change-over, 10/15 amps. 10/- each. Also Santon types and many others.

CRYSTAL OVENS. Type TC9. 6V 15 amps. Complete with Crystal AR3. Frequency 655.7. 35/-.

UNISELECTOR SWITCHES. 8-bank 25-way 1-wiper, 37.5 ohms. 40/- each. Full wipers, 45/- each.

MIRROR GALVANOMETERS, 30 microamps per standard scale, 20 in. sweep, strong construction, 5 in. by 3 in., £7. 10s. each.

19, LANSDOWNE ROAD, CROYDON
CRO 0839

NORTHAMPTON POLYTECHNIC

St. John Street, London, E.C.1.

A Course of Six Lectures on A SURVEY OF MICROWAVE INSTRUMENTATION

will be given by a Group of Specialists on
Wednesday Evenings at 7 p.m., beginning Feb. 13th, 1952.

A Course of Twelve Lectures on THE INDUSTRIAL APPLICATIONS OF HIGH VACUUM TECHNOLOGY

will be given by a Group of Specialists from Industry on certain
Tuesday and Thursday Evenings, from Feb. 26th to
May 27th, 1952.

FEE FOR EACH COURSE, £1

Full particulars are obtainable from the Secretary.

"J.B." SERVICE (BEXLEYHEATH) LTD.

5 MAYPLAGE ROAD WEST, BEXLEYHEATH, KENT

OFFER

SIGNAL GENERATOR, NAVY MODEL, TYPE LAD. FREQUENCY COVERAGE, 2,700-2,900 Mc/s. POWER SUPPLY, 115V, 50-80 CP/S. THIS INSTRUMENT CONSISTS OF A MICRO-WAVE CAVITY OSCILLATOR USING A 446B LIGHTHOUSE TUBE AND IS INTERNALLY PULSE MODULATED. £45.
MODULATOR UNIT BC-1203-A (TEST EQUIPMENT IE-45-A) DESIGNED FOR USE WITH SIGNAL GENERATOR, TYPE 804C OR EQUAL. £20.
GALVANOMETERS, MIRROR TYPE, PERMANENT MAGNET FIELD, SENSITIVITY 30 MICROAMPS PER STANDARD SCALE, 20° SWEEP. £7 10s. EACH. (SPECIAL PRICE FOR QUANTITIES ON APPLICATION.)
PRESTCOLD REFRIGERATION UNIT FOR RIVET STORAGE METERED TEMPERATURE DOWN TO 10° C. REDUCED PRICE TO CLEAR LAST ONE. £10 EX-LONDON.

MAGNETIC RELAYS

LARGEST STOCK IN
GREAT BRITAIN OF RELAYS,
KEY SWITCHES AND
UNISELECTORS

Government Contractors

RELAYS P.O. 3000 - 600 - SIEMENS' HIGH SPEED.
400v. A.C. 50cy.

ALL NEW EX-MINISTRY GOODS

JACK DAVIS (Relays) LTD. DEPT. E.E.
36 PERCY STREET, LONDON, W.1.

Phones: MUSEum 7960 LANgham 4821

Miniaturised Transformers

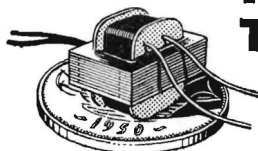

The high efficiency of these very small transformers is due to the special laminations, hydrogen annealed after stamping. Size of Transformer shown: $\frac{3}{8}'' \times 7/16'' \times \frac{1}{2}''$ dia. bobbin.

Primarily developed for hearing aids, the miniature transformers we manufacture have been found eminently suitable for use in small portable radios, radio control work, communications and model making. Inquiries invited for miniature transformers in small or large quantities, also for other miniaturised components.

JOHN BELL & CROYDEN
117, HIGH STREET, OXFORD 'Phone 48362



POTENTIOMETERS

Wire-wound and Composition types. Single, Ganged, Tandem Units. Characteristics: linear, log., semi-log., non-inductive, etc. Full details on request.

RELIANCE

RELIANCE MFG., CO. (SOUTHWARK), LTD.,
SUTHERLAND ROAD, HIGHAM HILL, WALTHAMSTOW, E.17.
Telephone: Larkwood 3245

WE TALK YOUR LANGUAGE when it comes to TRANSFORMERS

- ★ designed for standard & special applications.
- ★ built for reliability.
- ★ engineered for trouble-free operation.



TRANSFORMERS BY *Amos of Exeter* A.I.D. APPROVED
AMOS OF EXETER, RTS WORKS, COWICK STREET, EXETER.

INDEX TO ADVERTISERS

Acheson Colloids Ltd.	45	Edison Swan Electric Co., Ltd., The	34	Nagard Ltd.	29
Air Control Installations Ltd.	32	Edwards & Co. (London) Ltd., W.	44	Northampton Polytechnic	51
Airmec Laboratories Ltd.	38	Egen Electric Ltd.	47	Oxley Developments Co., Ltd.	50
Allied Electronics Ltd.	37	Electro-Alloys Ltd.	47	Painton & Co., Ltd.	3
All-Power Transformers Ltd.	42	Electronic Engineering Monographs	91	Parmeko Ltd.	25
Amos of Exeter	51	E.M.I. Institutes Ltd.	48 & 50	Partridge Transformers Ltd.	8
Audigraph Ltd.	50	Eric Resistor Ltd.	Cover iv	Pitman & Sons, Ltd., Sir Isaac	48
Automatic Telephone & Electric Co., Ltd.	31	Evershed & Vignoles Ltd.	22	Radiospares Ltd.	50
Autoset (Production) Ltd.	46	Ferranti Ltd.	16	Redifon Ltd.	45
Baker Platinum Ltd.	28	Furzehill Laboratories Ltd.	40	Reliance Mfg. (Southwark) Ltd.	51
Bell & Croydon, John	51	Gardner's Radio Ltd.	37	Rollet & Co., Ltd.	46
Belling & Lee Ltd.	23	General Electric Co., Ltd., The	21	Salford Electrical Instruments Ltd.	12
Bradmatic Ltd.	50	Goodmans Industries Ltd.	40	Salter & Co., Ltd., George	17
Bray & Co., Ltd., George	48	Grampian Reproducers Ltd.	29	Sankey & Sons, Ltd., Joseph	Cover ii
British Insulated Callender's Cables Ltd.	Cover i	Hifi Ltd.	50	Spear Engineering Co., Ltd.	50
British Physical Laboratories Ltd.	49	Hivac Ltd.	47	Standard Telephones & Cables Ltd.	10
Castle Engineering Co. (Nottingham) Ltd., The	49	Hogg, F. Livingston	41	Steatite & Porcelain Products Ltd.	13
Chance Bros.	38	"J.B." Service Ltd., The	51	Taylor, Tunnicliff (Refractories) Ltd.	9
Chapman & Hall Ltd.	91	Le Carbone Ltd.	52	Telegraph Condenser Co., Ltd., The	Cover iii
Cinema-Television Ltd.	20	Lyons Ltd., Claude	47	Telegraph Construction & Maintenance Co., Ltd., The	27
Cole Ltd., E. K.	5	Marconi Instruments Ltd.	19	Tufnol Ltd.	7
Cole Ltd., E. K.	5	Marconi's Wireless Telegraph Co., Ltd.	14	United Insulator Ltd.	36
Connolly's (Blackley) Ltd.	24	Measuring Instruments (Pullin) Ltd.	41	Vortexion Ltd.	33
Cossor Ltd., A.C.	30	Metropolitan-Vickers Electrical Co., Ltd.	11	Walter Instruments Ltd.,	18
Darwins Ltd.	39	Miltoid Ltd.	46	Wayne-Kerr Laboratories Ltd., The	43
Davis (Relays) Ltd., Jack	51	Minnesota Mining & Manufacturing Co., Ltd.	35	Whiteley Electrical Co., Ltd.	27
Derby & Co., Ltd.	49	Muirhead & Co., Ltd.	15	Wiggin & Co., Ltd., Henry	5
Donovan Electrical Co., Ltd.	49	Mullard Ltd.	26, 39 & 43	Wilkinson, L.	51
Du Bois Co., Ltd., The	36	Murex Ltd.	42	Woden Transformers Co., Ltd.	48
				Wright, Bindley & Gell Ltd.	44

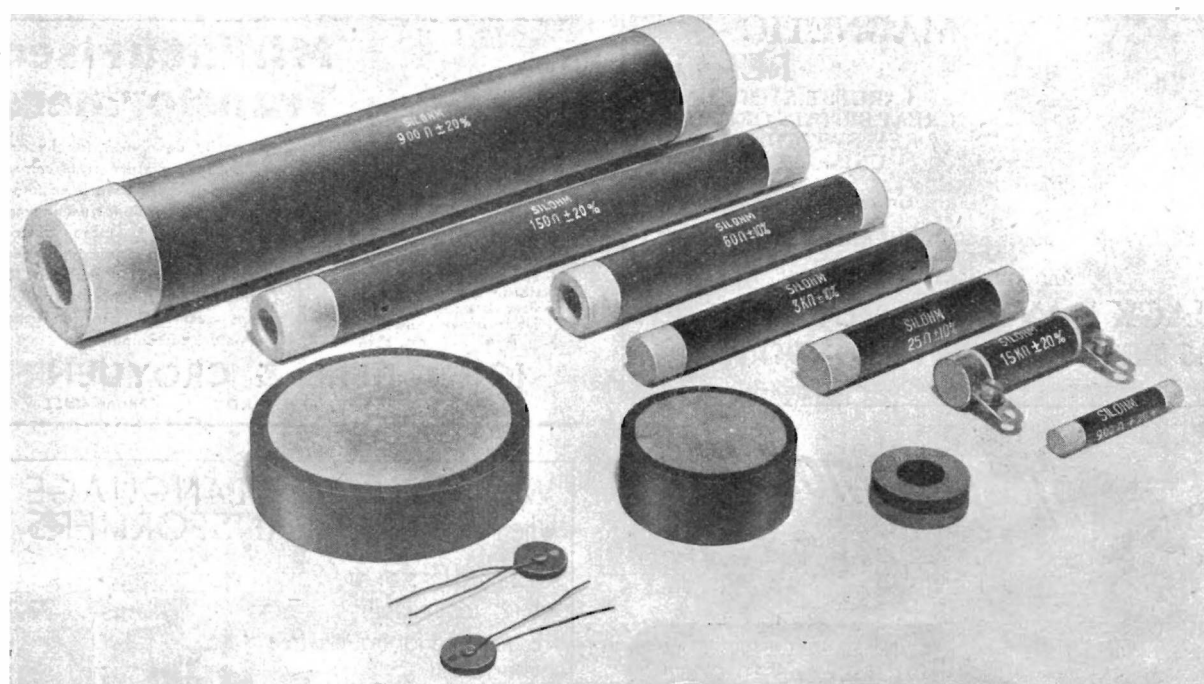

RESISTANCES

"SILOHM" (LINEAR)
"CARBOHM" (NON-LINEAR)

NON-INDUCTIVE

NON-METALLIC

LE CARBONE LTD.,
PORTSLADE, SUSSEX.

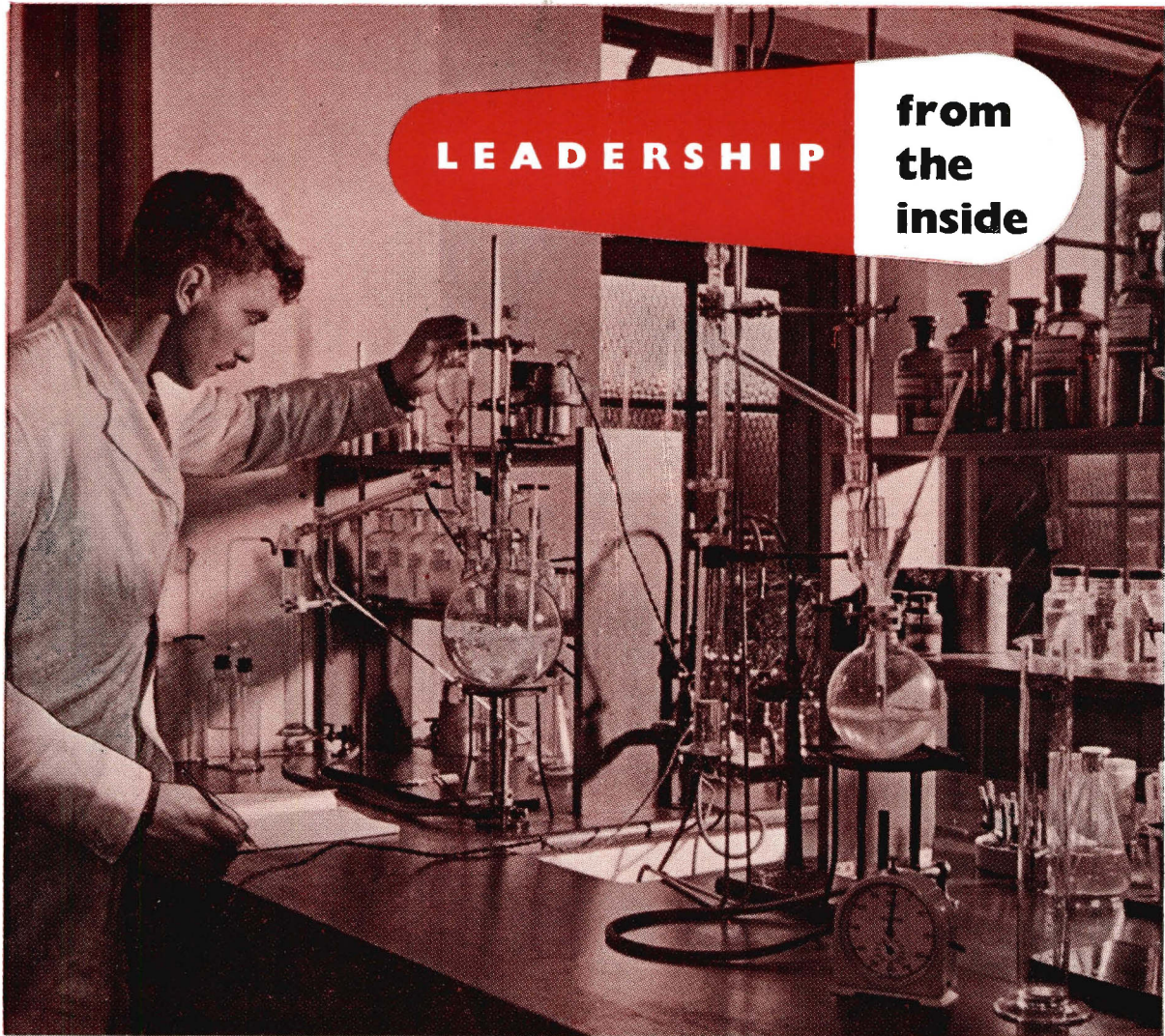

LEADERSHIP from the inside



*Quest and Test—symbols of
Condenser Perfection*

The task of the laboratory worker is often dull: only occasionally do the results of some original work assume proportions sufficient to glorify his monotonous routine.

We test all raw materials before approving them for use, and test to destruction all new types developed by the designs department. These are everyday tasks, but our chemists also carry out research on new materials which may result in the adoption of an entirely new manufacturing technique.

Research can never reach finality: it must keep abreast—and indeed ahead—of changing conditions and fresh applications.

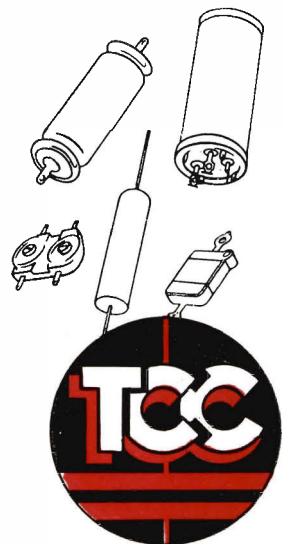

SPECIALISTS IN CONDENSERS SINCE 1906

THE TELEGRAPH CONDENSER CO. LTD · RADIO DIVISION · LONDON · W.3 · Tel: ACORN 0061 (9 lines)

ERIE *Silertex*

REGD. TRADE MARK

Wirewound Resistors



SILERTEX wirewound resistors are used by all the leading manufacturers because:

- * They resist moisture at extremes of temperature.
- * They withstand greater overloads.
- * They have high operating temperature range over high ambients.
- * They are fire resistant.
- * Wire connections are welded to the resistance wire.
- * Low firing temperature in manufacture avoids damage to resistance winding.

Erie Silicone bonded SILERTEX wirewound resistors are made for temperatures of 200° C.

When you need power resistors which have proved their ability to stand up in these conditions at all times,

Specify **SILERTEX**

ERIE RESISTOR LIMITED

CARLISLE ROAD, THE HYDE, LONDON, N.W.9. 'Phone: Colindale 8011. Cables: Resistor, London

Factories: LONDON & GT. YARMOUTH, ENGLAND; TORONTO, CANADA; ERIE, PA., U.S.A.