

Electronic Engineering

INCORPORATING ELECTRONICS, TELEVISION AND SHORT WAVE WORLD

**PRINCIPAL
CONTENTS**

Logarithmic Charts and Circuit Performance

Mycalex—Its Properties and Manufacture

X-Ray Analysis in Industry

Differential Input Circuits for Biological Amplifiers

The Electron—Recent Progress

21-MAY, 1942

X Make a Note of it!

PUBLICATION C-III-A

INSTRUMENT DIALS & CONTROL KNOBS



Our latest catalogue, Publication No. C-III-A, fully illustrates and describes over 60 different Dials, Drives, Scales, Knobs and Miscellaneous Parts which are of vital interest to designers and manufacturers of electrical instruments.

REMEMBER — PUBLICATION C-III-A

A copy will be supplied on request.

MUIRHEAD

MUIRHEAD & CO. LTD.
ELMERS END, BECKENHAM, KENT
BECKENHAM - 0041-0042

FOR OVER 60 YEARS DESIGNERS AND MAKERS OF PRECISION INSTRUMENTS



'AVO'

ACCURATE TESTING INSTRUMENTS

HIGH accuracy, simplicity, exceptional versatility and proven reliability have won for "AVO" Instruments a world-wide reputation for supremacy wherever rapid precision test work is demanded. There is an "AVO" instrument for every essential electrical test.

Some delay in delivery of Trade orders is inevitable, but we shall continue to do our best to fulfil your requirements as promptly as possible.

The word "AVO" is our registered Trade Mark

● Send for descriptive literature and current prices.

THE AUTOMATIC COIL WINDER & ELECTRICAL EQUIPMENT Co., Ltd.
Winder House, Douglas Street, London, S.W.1. Phone: VICTORIA 3404-7

SALFORD METAL RECTIFIERS

COPPER OXIDE TYPE.

For Radio and Telecommunication applications, X-ray H.T. Rectifiers, Relay and Contactor operation, Electrical Precipitation equipment, Surge Absorbers, Metallic Sputtering apparatus, H.T. and E.H.T. Insulation Test equipment, etc.

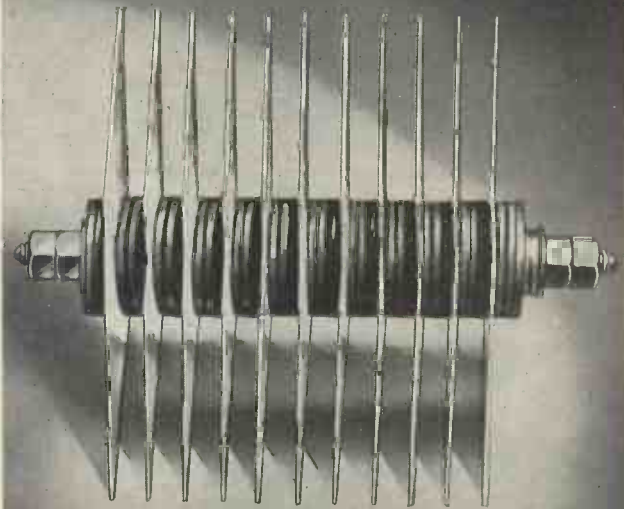

Please send your enquiries to—

SALFORD ELECTRICAL INSTRUMENTS LTD.

PEEL WORKS, SALFORD, 3. Telephones: BLACKIRONS 4688 (6 lines) Telegrams and Cables: "Sparkless, Manchester"

PROPRIETORS: THE GENERAL ELECTRIC Co. Ltd., OF ENGLAND

Connect-

with TUCKER-TAGS

GEO. TUCKER EYELET CO. LTD. • WALSALL ROAD, BIRMINGHAM, 22 • Phone: BIRchfields 5024

U.I.C.

Silvered Mica Condensers

AVAILABLE IN CAPACITIES FROM 5 to 10,000 PF.

Only highest grade raw materials used. Continuous and rigorous mechanical and electrical tests ensure efficiency and dependability. Type approved tropical finish on request.

Full details and advice gladly given.

UNITED INSULATOR CO. LTD.
 12-20, LAYSTALL STREET, LONDON, E.C.1
 Phone: TERminus 7383
 Grams: CALANEL, SMITH, LONDON

CONTRACTORS TO G.P.O. & GOVERNMENT DEPARTMENTS ON A.I.D. APPROVED LIST.

The Pioneers of Low Loss Ceramics

METALASTIK IN PRACTICE

A few examples from the hundreds of applications of RUBBER-TO-METAL Welding



Cross Type Mounting



Instrumounting



Instrumounting



F.S. Mounting



Engine Mounting



Heavy Duty Mounting



Z. Coupling



Wedge Type Coupling



Heavy Duty Coupling

Consult us on all your vibration problems—they can be solved by Metalastik.

METALASTIK

ANTI-VIBRATION UNITS



*What chance has a
Celluloid Cat?*



Not much, has it? Yet, do you realise that in your own works a small fire can become out of control in a matter of minutes and should your fire patrol happen to be in another part of your premises at the time they may be too late. One man stationed at each of your vulnerable points 24 hours a day can do no more than one Methyl Bromide Installation taking care of your whole risk. Because there is literally nothing to compare with Methyl Bromide we invite you to let us prove, by facts and actual demonstration that Methyl Bromide alone can solve your fire protection problem.



THE NATIONAL FIRE PROTECTION CO. LTD.
PETERSHAM ROAD, RICHMOND, SURREY. Tel: RICHMOND 2342-3-4



At the back

DELARON
LAMINATED MATERIAL

holds the lead(s)

P.U., A.E., EX. L.S.—in fact, wherever you find Terminal Strips you'll often find they're made from "DELARON"—a high-grade material available in Fabric and Hard Paper Sheets to Air Ministry and Ministry of Supply approved grades. Special panels and strips gladly cut to order. Fullest details, samples and prices on request.



5, Regent Parade, Brighton Road,
Sutton, Surrey. Tel.: Vigilant 4472.

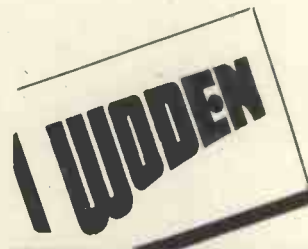

**Its the little things
that count . .**

A transformer is only a small part of your assembly, but on its reliability depends the proper functioning of the whole equipment. Woden Transformers are being used more and more where reliability is all important.

*Woden make transformers of every type
from 10VA-10kVA*



TRANSFORMERS

WODEN TRANSFORMER CO.

Thornley Street, Wolverhampton Tel.: Wolverhampton 22829
Makers of Transformers, Power Packs, and Special Receiving and Transmitting Apparatus

The sign of a

**GOOD
RECTIFIER**

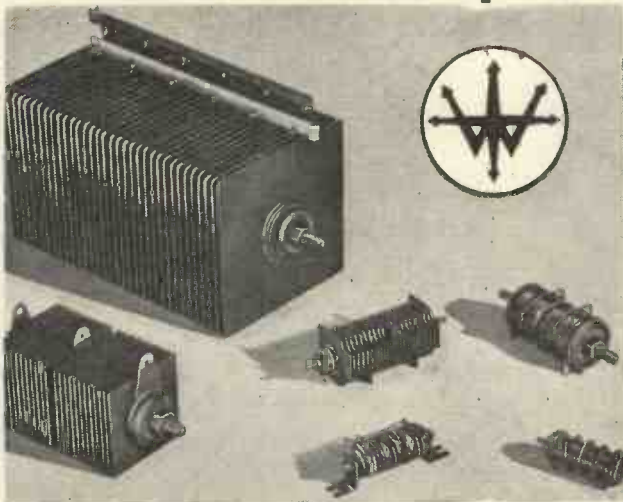

WESTINGHOUSE

Westinghouse Brake & Signal Co., Ltd.
Pew Hill House, Chippenham, Wilts.

HEWLETT-PACKARD

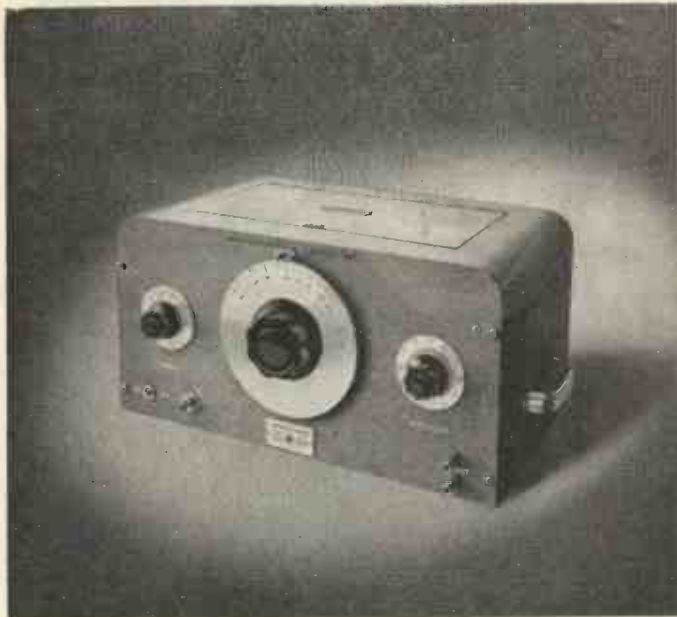

LELAND INSTRUMENTS LTD. Resistance tuned Oscillator model 200 illustrated. Write for details of complete range.
43 MECKLENBURGH SQ. LONDON. W.C.1.
TELEPHONE: TERMINUS 5689

CLOUGH-BREngle • BOONTON • FERRIS • BALLANTINE • HEWLETT-PACKARD

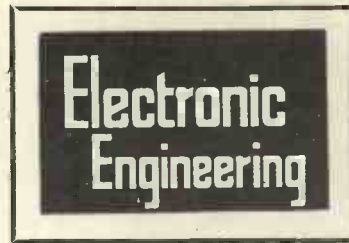

MAY, 1942.

Volume XIV.

No. 171.

CONTENTS

	PAGE
Editorial	743
Logarithmic Charts and Circuit Performance	745
Mycalex—Its Properties and Manufacture ...	749
A Note on RC Oscillators	752
X-Ray Analysis in Industry	753
Frequency Modulation—Part 7—concluded ...	755
Differential Input Circuits for Biological Amplifiers	760
Book Reviews	763
The Electron—Recent Progress	764
Measurement of Frequencies below 15 kc/s	767
Measurement of the Slope and Duration of Television Synchronising Impulses ...	768
Abstracts of Electronic Literature	771
Patents Record	772
Notes from the Industry	774

SYMBOLS OF PRECISION

TEMPERATURE RECORDER

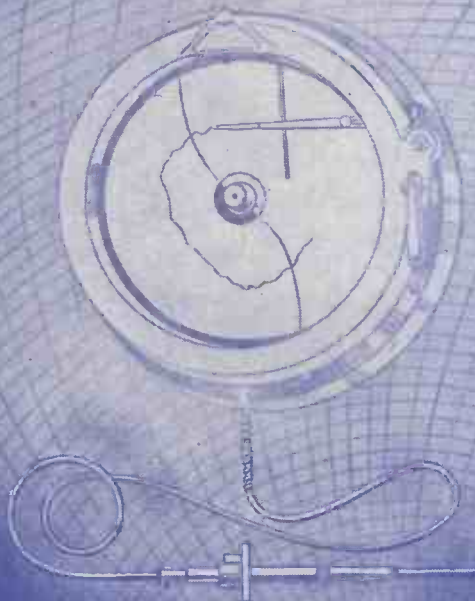

MAZDA

RADIO VALVES

Mazda Radio Valves are manufactured in Gl. Britain for the British Thomson-Houston Co. Ltd., London & Rugby, and distributed by

THE EDISON SWAN ELECTRIC CO. LTD  155 CHARING CROSS RD., LONDON, W.C.2

For full particulars write to Technical Service Department

PROPRIETORS :

HULTON PRESS LTD.,

Electronic Engineering

EDITOR

G. PARR.

EDITORIAL, ADVERTISING AND PUBLISHING OFFICES, 43-44, SHOE LANE, LONDON, E.C.4

TELEPHONE :
CENTRAL 7400

Monthly (published last day of preceding month) 2/- net. Subscription Rates : Post Paid to any part of the World—3 months, 6/6; 6 months, 13/-; 12 months, 26/-. Registered for Transmission by Canadian Magazine Post.

TELEGRAMS :
HULTONPRES LUD
LONDON.

Vol. XIV

THIS issue completes Vol. XIV, which contains an unusually large number of parts owing to the changeover in title and style in June last year.

The Editor and Publishers feel that under the present conditions they cannot recommend the permanent binding of the issues, as materials for a high quality binding cover are not available, nor is the labour for binding.

The supply of a cheaper quality cover is not in keeping with the standard that has been set for this Journal and it has therefore been decided to wait until a suitable standard cover can be produced to give a uniform appearance to bound volumes on library shelves.

In the meantime, arrangements are being made to provide a "self-binder" in which the issues can be kept safely, and which will also serve to contain current issues when the permanent binder is available.

This self-binder is in stiff blue board with strings fitted in the spine through which the copies can be slipped to keep them in place, and will hold a maximum of 24 copies. It will be obtainable from the Publishing Department at this office, price 3s. 6d. post free. Applications should be made direct to the Department and should be accompanied by a postal order for the amount.

Index.

The Index to Vol. XIV will be in two sections, one covering the issues of ELECTRONICS AND TELEVISION from January to May, 1941, and the other issues of ELECTRONIC ENGINEERING from June, 1941, to May, 1942, and

will be printed as soon as possible in a form convenient for binding with the Journal.

Finally, binding covers for past issues of ELECTRONICS AND TELEVISION AND SHORT WAVE WORLD are still available, price 1s. 9d., post free, from the Publishing Department.

Data Sheets.

The Data Sheets, which have been a feature of the first volume of this journal and which have received many expressions of approval, will be continued in succeeding issues. The break in the series in this issue has been made to accommodate Dr. Sturley's circuit diagram, and next month's Data Sheet will appear as usual.

A number of readers have purchased extra copies of data sheets complete with binder, and in order to enable them to maintain their collection it is proposed to institute a limited service of which they are invited to take advantage.

Batches of data sheets will be posted quarterly to all readers registered as holding extra binders, the charge for a year's supply being 7s. 6d. including postage. Errata slips (an unfortunate necessity), and a revised index will be included in the service. A separate reminder will be sent to holders of complete binders, and provided that they do not delay their request for the service unreasonably there will be no break in the continuity of the sheets.

A limited number of binding covers for Data Sheets are still available, price 2s. 6d., post free.

The supply of complete binders is now exhausted, but some are available less Data Sheets IX-XI, XVIII, and XXIII-XXV.

Endeavour will be made to replace these missing sheets as soon as the paper supply enables reprints to be made, and readers are strongly advised to take the opportunity of obtaining the binder while stocks last.

Acknowledgments.

The Editor and Publishers once again thank those readers who have written to express their appreciation of the Journal and the efforts which are being made to provide up-to-date information on all matters in the electronic field.

While it is impossible to predict what the next year will show, or what further restrictions will be necessary in paper and printing, they will continue to do their best to cover the subject accurately and informatively and hope that the completion of the next volume will see this journal steadily expanding with paper rationing a thing of the past.

URGENT—PRIORITY

You'd be surprised at the number of "indispensable" books and papers that are never used. Some of them are out of date under present conditions—some of them have information that is duplicated elsewhere.

If you have not already sorted out the books in your bookcase, please make it a priority job. One day earlier makes all the difference to the war effort.

Your local council will collect bulky packages at no expense to yourself.

Make a memo. and mark it : **URGENT. PRIORITY.**

Paper and cardboard salvage is vital to the war industry—save all you can.

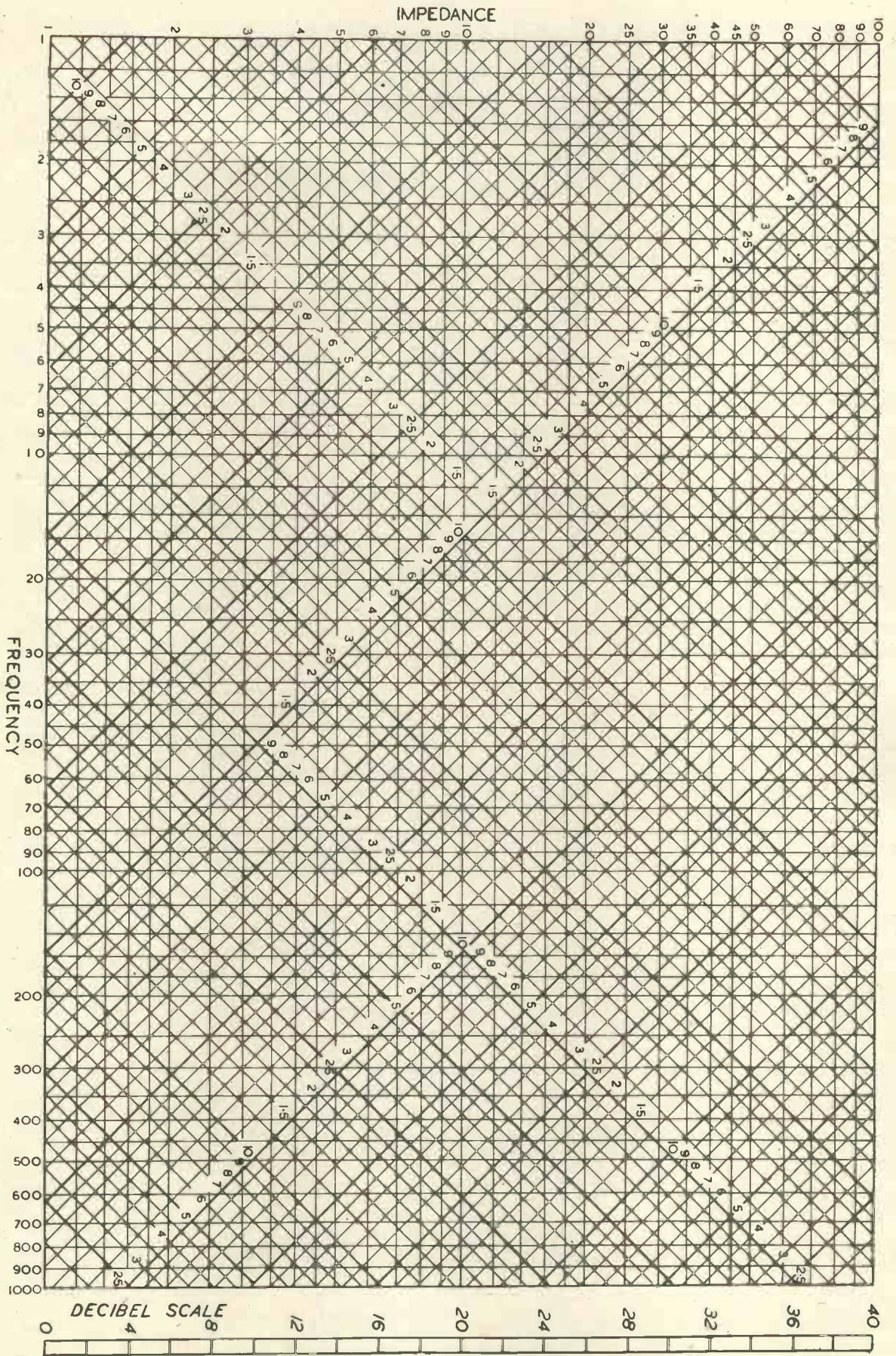

Fig. 3. Logarithmic Impedance-Frequency Chart.

Logarithmic Charts and Circuit Performance

Part I By D. N. Truscott, Sc.D., Ph.D.*

The object of the present article is to outline a graphical method of dealing with circuit problems where a wide range of frequencies is involved. Whereas the power engineer is most often interested in problems in which the load is the variable, the communications engineer has to treat those with variable frequency and special methods have to be developed. The first purpose of the method outlined is to enable the rapid graphical determination of the performance of circuits consisting of a number of elements over a range of frequencies and with slide rule accuracy. The charts use logarithmic scales, which give constant accuracy and wide range; these scales have the further advantage of enabling the attenuations to be read directly and handle circuits with parallel connexions as easily as those with series. It is also shown that the charts may be used in many simple cases for the direct synthesising of circuits having a given attenuation versus frequency characteristic.

It is suggested that the simplicity and directness of the method may appeal to teachers as giving a graphic picture of the behaviour of circuit elements in combination.

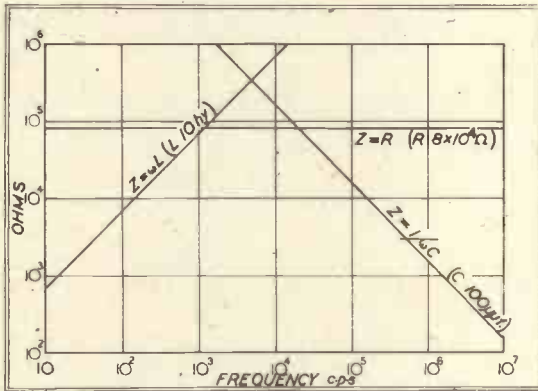

Fig. 1. (Left). Basic chart showing resistance, capacitive and inductive reactance plotted against frequency.

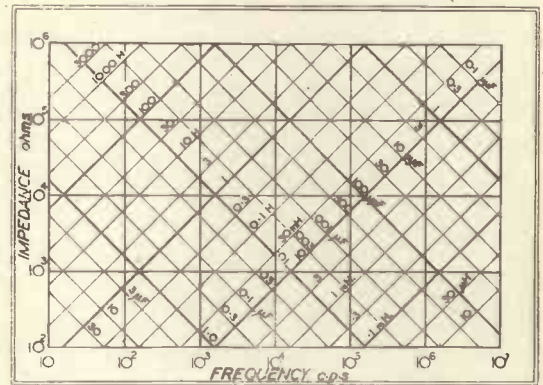

Fig. 2. (Right). A similar chart with lines covering a wide range of impedance values.

IN many branches of electrical engineering it is necessary to know the behaviour of circuits as a function of frequency; instances in radio receiver work are negative feedback filters, tone correction networks, and so on. The normal methods of determining the frequency characteristics of such circuits involve a considerable amount of calculation, inasmuch as the impedance of each section has to be worked out at each frequency, or, alternatively, the complete general expression for the network must be formulated. In either case the result does not lend itself to visualisation of the effect of the individual components over the range of frequencies or of any approximations that may be made.

The use of a chart having logarithmic scales of impedance and frequency is well known as a rapid means of determining the impedance of a given component at any frequency; the object of the present article is to draw attention to the value of similar charts in general circuit work where slide-rule accuracy is sufficient and the circuits are not unusually complicated.

Circuit Elements

The behaviour of a circuit over a range of frequencies depends upon the behaviour of its elements, which is indicated on the chart of Fig. 1. The vertical scale of the chart is $\log |Z|$ and the horizontal scale $\log \omega$, but the axes are marked directly in

values of impedance and frequency, so that no conversion is necessary.

A resistance has a constant impedance at all frequencies, and so is represented by a horizontal straight line across the chart.

The impedance of an inductance rises with frequency, and is represented by a line inclined up at 45° to the frequency axis, while that of a capacity falls with frequency and so is a line inclined downwards at the same angle.

The fact that the impedances of the circuit elements, resistance, inductance, and capacity, are all represented by straight lines on the chart is of fundamental importance to the method to be described, because, as a direct result, the impedance obtained by combining any two or three of these elements is represented by a curve of constant shape (which may be drawn as a template). The effect of a change in values is a displacement of the curve without change in shape, and its position alone is dependent upon the values of the particular elements. This will be explained in more detail below. Fig. 2 is a chart of the impedances of the three elements, covering a range of 10 to 10^7 c.p.s. in frequency and 100 to 10^6 ohms in impedance. The range covered is large and so the reading accuracy is small, but the values repeat in cycles of 10 , so that we may draw a greatly magnified cycle and use the original chart to determine the position of the decimal points in the result. Fig. 3 is such an en-

larged section, being made to cover 6 cycles for convenience. Having reviewed the ground on the single elements, which is probably familiar, we can now look at the combinations of two or three elements.

Series Connexion of Resistance with Inductance or Capacity.

Consider the lines representing the impedances of the resistance R and inductance L of a simple series circuit. Let ω_0 be the frequency at which they intersect, then

$$|Z| = \sqrt{R^2 + \omega^2 L^2}$$

$$= R\sqrt{1 + (\omega^2/\omega_0^2)}$$

and, taking logarithms,

$$\log |Z| = \log R + \log [\sqrt{1 + (\omega^2/\omega_0^2)}]$$

This shows that the curve representing $|Z|$ has a constant shape, independent of the values of R and L ; the position of the curve is determined by the value of R and the frequency ω_0 where the lines intersect. This means that we can make a drawing of this curve and use it to give the impedance of any series R, L circuit at all frequencies by placing it in the correct position on the chart of Fig. 3. The actual curve is given in Fig. 4a, and it will be seen that the total impedance is very closely that of one of the elements except in the region where their impedances are nearly equal, as would be expected.

An exactly similar argument follows for the series connexion of resistance and capacity and the curve for this is also given in Fig. 4a.

* Ministry of Aircraft Production.

Parallel Connexion of R with L or C:— The impedance of a circuit having resistance R and inductance L in parallel is given by:

$$\frac{I}{|Z|} = \sqrt{\frac{I}{R^2} + \frac{I}{\omega^2 L^2}} = \frac{I}{R} \sqrt{1 + \frac{\omega_0^2}{\omega^2}} \quad \text{where } \omega_0 L = R.$$

Taking logarithms we have:

$$-\log |Z| = -\log R + \log \left[\sqrt{1 + \frac{\omega_0^2}{\omega^2}} \right]$$

or

$$\log |Z| = \log R - \log \left[\sqrt{1 + \frac{\omega_0^2}{\omega^2}} \right]$$

This is plotted in Fig. 4b, and will be seen to be a similar curve to that for the series connexion except that it is inverted about the point of intersection.

It is important to notice here that we can determine the impedance of the parallel circuit from the chart, with this curve, without converting to admittances and re-converting to impedances. This arises from the fact that $\log 1/|Z| = -\log |Z|$ which involves a change of sign only, and this is cancelled on returning to the impedance scale.

A similar result applies for the parallel connexion of resistance and capacity. For convenience all four template curves are drawn on the same sheet (Fig. 5) and no confusion should arise if it is remembered that the impedance of series and parallel

circuits are respectively always greater and less than that of either of their elements.

Attenuation

The simplest and the most common of the circuits giving an output differing from the input is the T circuit formed by the series connexion of two impedances Z_1, Z_2 , such as is shown in the figure. Taking the input across

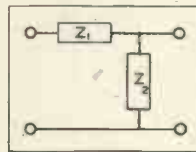

the two impedances and the output across Z_2 , the ratio of the output to the input voltage is (since the same current flows through both):

$$E_2/E_1 = |Z_2| / |(Z_1 + Z_2)|$$

taking logarithms:—

$$\log E_2/E_1 = \log |Z_2| - \log |(Z_1 + Z_2)|$$

or, by the definition of the decibel:—
Attenuation in db.

$$= \log |Z_2| - \log |(Z_1 + Z_2)|$$

This means that if we have the curves for $|Z_2|$ and $|Z_1 + Z_2|$ on our chart, we can read off the attenuation of the circuit as the vertical distance between the lines at each frequency, the scale for this is given at the right-hand side of Fig. 3.

In some practical cases we may be given the converse case, that is: given the load input impedance and the attenuation required, to determine the circuit. This occurs in tone correction of gramophone pick-ups, etc. Here we draw the impedance curve representing the load impedance, add the attenuation at each point, and the resulting line is the total impedance $|(Z_1 + Z_2)|$ needed to give the required performance; by fitting the template curves to this resultant total impedance it can be broken up into its constituent parts, and the necessary circuit elements read off. An example of Part II) is given in the Appendix (Part II).

Resonant Circuits.

It can be shown in the same way as was done in the case of the series R and L circuit that the impedances of series and parallel resonant circuits having no resistance are represented

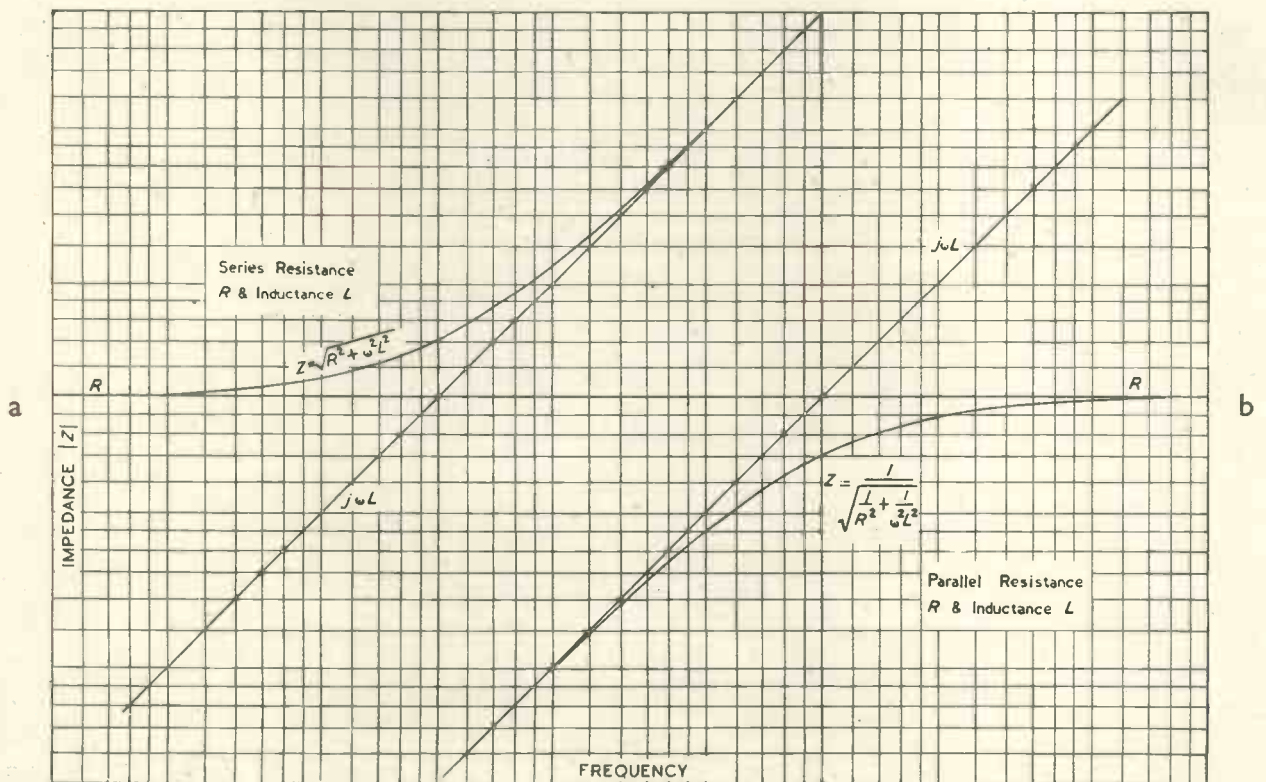

Fig. 4. (a and b). Curves of impedance for series and parallel connexion of inductance and resistance. These are not to scale of Fig. 3.

Fig. 5. Curves of series and parallel connexion of C, L and R drawn to the same scale as Fig. 3. The marks on the curves are degree markings.

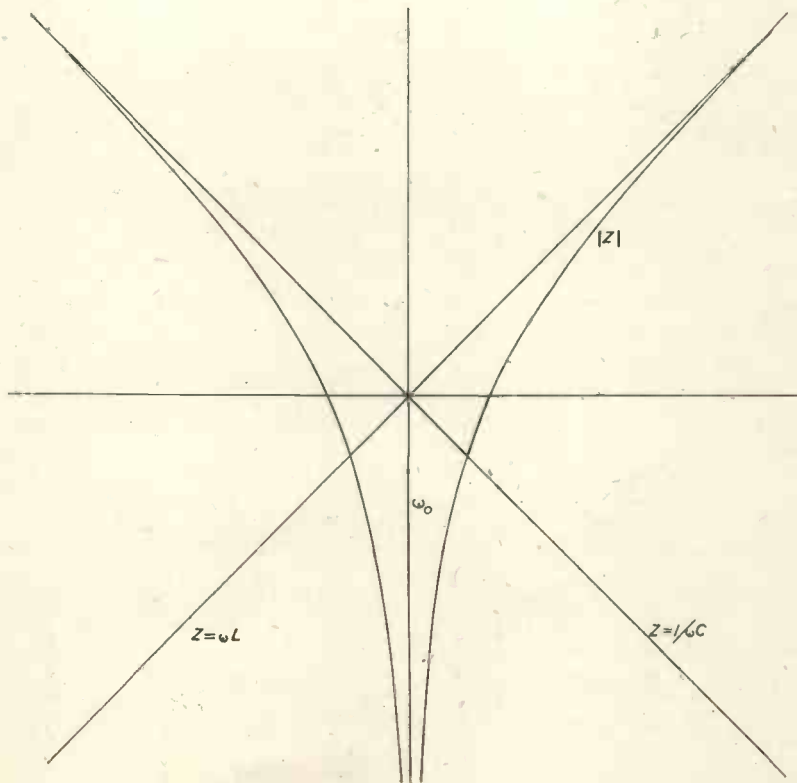
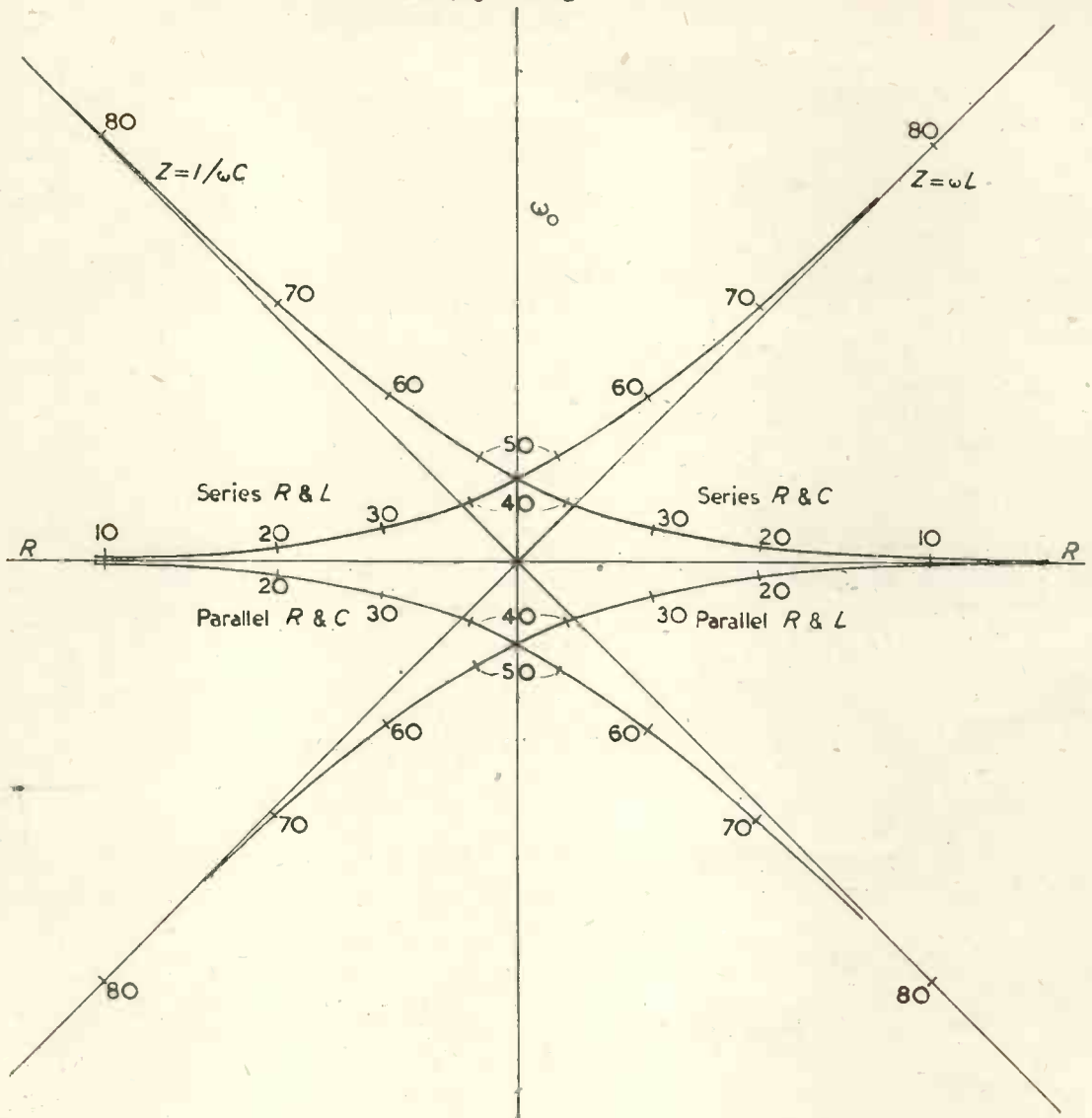

Fig. 6. Curves of series and parallel resonant circuits, not to same scale as above. For parallel circuits the curves are inverted.

by single curves whose position on the chart depends only on the values of the elements. This curve is given in Fig. 6, for series circuits, and is inverted for parallel circuits.

Notice that in the case of the series resonance the impedance of the whole circuit is less than that of one of the elements, giving a negative attenuation by following the procedure of the previous section and a gain as is well known in practice.

Resonant Circuits with Resistance

The height, or depth, of the peak in the resonant circuit impedance curve depends upon the value of the resistance in the circuit; in the case of the series circuit the minimum impedance is exactly that of the resistance and the curves of Fig. 7 show the shapes of the curves for several different values of resistance (expressed as a ratio to R_0 , the impedance at the

intersection of the impedance lines of the inductance and capacity).

In the case of the parallel circuit, if $R = \omega_0 L / Q$, where ω_0 is the frequency of the intersection of the inductance and capacity lines, then the maximum value of the impedance Z is

$$Z = Q^2 R$$

in which R is the series resistance in the circuit and Q is assumed much greater than unity. Taking logarithms this gives

$$\log Z = \log R + 2 \log Q$$

and, since $\log Q = \log \omega_0 L - \log R$ this gives the peak of the curve at the same distance above the intersection of the inductance and capacity lines as the resistance line is below.

Method of using the Charts.

The most convenient method of using the charts has been found to work on tracing paper fixed along one side of the large chart of Fig. 3. This

will allow other curves, such as those of Figs. 5 and 7 to be introduced underneath.

An alternative method is to trace the boundaries of Fig. 3 on tracing paper and move this over the basic chart as required. Figs. 5 and 7 have been reproduced in correct scale relationship to Fig. 3 and can be used to cut templates or copied on tracing paper. A slight discrepancy may be introduced due to paper shrinkage, but this is unavoidable.

It is often convenient to have the actual attenuations of the series resonant circuit drawn out for various resistances and charts showing these will be given next month.

From the foregoing it will be clear that the system can be extended to include the addition of impedances at any angle and to give both phase relationships and the magnitudes.

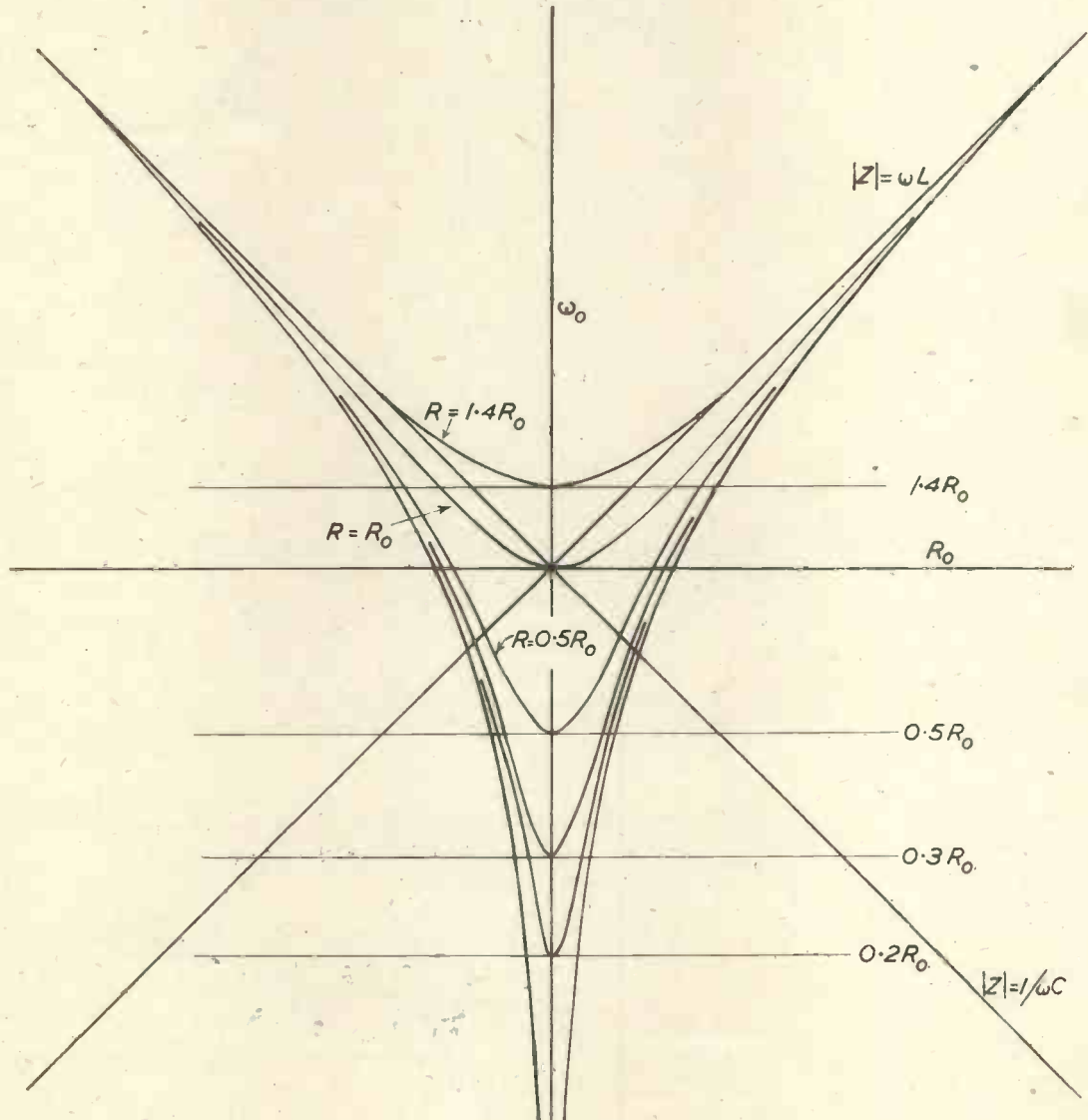
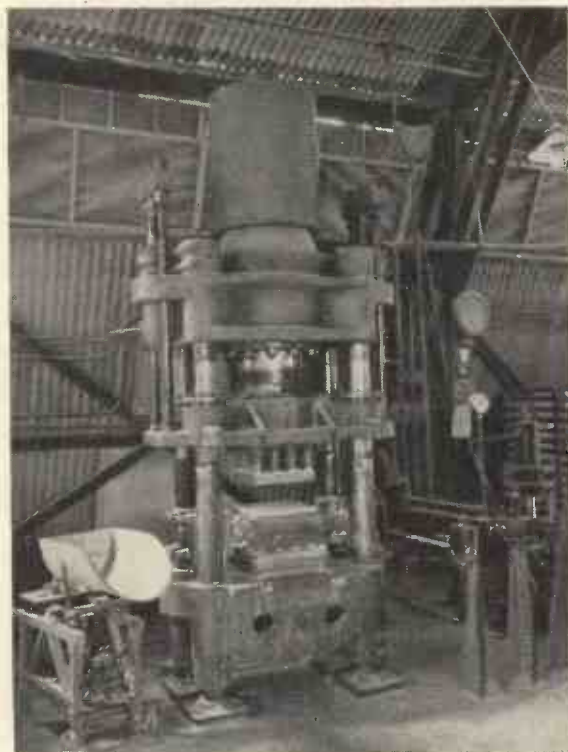

Fig. 7. To the same scale as Fig. 3. Curves illustrating the effect of resistance in resonant circuits.



Mycalex

Its Manufacture and Properties

Processes in the manufacture of Mycalex : Fig. 3 (left) Compressing the mica-glass mixture in a hydraulic press before final firing, and Fig. 2 (right), The glass ingredients undergoing preliminary baking before being mixed with mica flour.

MICA is one of the oldest electrical insulating materials and for many purposes the most satisfactory. It has a high dielectric constant (5-7), a high breakdown voltage and a low loss factor. Chemically it is a group of aluminium silicate compounds of which two—*Muscovite* and *Phlogopite* are principally used in insulation work.

Muscovite ($KAl_2(OH)_2Si_3AlO_{10}$) or Ruby mica, is obtained from India, and as the formula shows, contains a high proportion of silica. Phlogopite ($KMg_3(OH)_2Si_4AlO_{10}$) is the so-called "Amber Mica" containing an appreciable amount of ferric oxide, which renders it less suitable for high frequency work.

Both types of mica suffer from the limitation of low mechanical strength. As is well known, sheets of mica can be split from the solid block to thicknesses as low as .001 in., but except under compression their resistance to mechanical handling is poor and their insulating properties are easily reduced by cracking or tearing.

With the object of improving the mechanical strength of mica and at the same time retaining its high dielectric strength, various forms of bonding have been used to hold the sheets or flakes together—a common form of binder is shellac or bakelite varnish. The flakes have also been used with a backing of flexible tape to keep them intact when bent round a conductor.

In distinction to this method of obtaining cohesion between sheets of mica, the compound "Mycalex" is based on finely powdered mica dust which is intimately bonded with glass to make a homogeneous tough material with greatly improved mechanical properties.

The invention of Mycalex is credited to Mr. P. B. Crossley, who experimented with glass mica mixtures in 1919 and evolved a satisfactory compound which retained the desirable electrical properties of mica and at the same time had the advantage of the mechanical strength and heat-resisting properties of glass.

In the original form, lead borate glass was used with Muscovite, giving a high degree of insolubility and infusibility, but it was found that the machining operations presented considerable difficulty. Later, however, in 1930 a new type was developed using soda glass and Muscovite and it was found that while the electrical qualities had been retained the possibilities of machining were so improved that users were able to develop shapes with ordinary machine shop equipment. Leadless Mycalex is considered a considerable advance on the original product and the development is largely due to Mr. A. W. Wedlock, the present works manager of the Mycalex Co.

In 1928 the Mycalex Parent Co. was established at Harlesden and licences to

manufacture were granted to the Westinghouse Co. of America and the Quartz and Silica Co. of Paris.

The G.E. Co. of America had already (1921) acquired manufacturing rights and were responsible for much of the early developmental work in certain directions.

Manufacture

The manufacture of Mycalex involves the intimate mixing of mica dust with the ingredients of soda or lead glass and the compression of the mixture into flat slabs as a preliminary to fusing the glass bond round the mica particles. The views taken in the factory (Figs. 1 to 4) shows the principal stages in the process.

The mica, in the form of flakes is ground into ultra-fine particles by the grinders seen in Fig. 1, the mica "flour" collecting in the base of the machine.

At the same time the components of the glass binder are mixed and given a preliminary baking in the furnaces shown in Fig. 2.

The mica and glass are then intimately mixed in exact proportions and placed in a shallow tray under the hydraulic press (Fig. 3), the thickness of the slab being determined by the final thickness required in the finished product. After compression the slab is fed into the muffle furnace, through which it passes slowly, while the glass



Fig. 1. Grinding mica particles. The fabric bags at the back cover the air outlet from the grinder.

melts firmly round the mica particles (Fig. 4).

The red-hot slab is then allowed to cool gradually in an annealing furnace before being stacked for final machining processing.

Under the influence of heat the glass tends to settle in the centre of the slab, leaving an excess of mica particles on the surface, and this excess is then removed by grinding on each face of the slab. The final result is a homogeneous mass of mica and glass as the photomicrograph of Fig. 5 shows.

Machining

Contrary to what might be supposed, Mycalex does not display the brittle properties of glass and can be machined and drilled with comparative ease. The following notes on machining are given by the manufacturers and some examples of finished work are shown in the photographs of Figs. 6-9. Fig. 6 is particularly noteworthy as demonstrating the way in which Mycalex can be drilled without splintering—the only precaution taken being the use of a jig to prevent chipping at the edges. The drill must not be forced through the material in order to avoid breaking on the opposite side of the hole. It has been found that the most satisfactory way of finishing the hole is to reverse the plate when the cutting edge of the drill has just penetrated, and finish the hole from the opposite side.

It is of the utmost importance that stresses or strains are eliminated wherever possible when machining Mycalex, and when drilling larger holes, say upwards of $\frac{3}{4}$ in., the operator should first drill half the required diameter, and then, using this as a pilot hole, open up with a drill to the desired dimensions.

The tools for drilling Mycalex are of any good high-speed or carbon steel and the cutting speeds are obviously determined by the size of the drill, the feed being regulated, in the case of a hand feed drill by the skill of the operator. A good average speed for drills up to $\frac{1}{4}$ in. is 500 r.p.m. From $\frac{1}{4}$ in. to $\frac{1}{2}$ in. the speed will be reduced to approximately 200 r.p.m., the feed being about 2 in. per minute for a $\frac{1}{4}$ in. drill and varying according to the size of the latter.

It is not advisable to use any lubricant when drilling, since the waste powder in a wet form is apt to clog in the flutes of the drill.

Tapping and Threading

The procedure for the former opera-

tion is the same as that adopted for mild steel, except that water should be used as the cutting lubricant instead of oil, and it will be found that the tap will go through the material much faster. Provided the hole is drilled to the correct core diameter, the second tap can be started immediately, and the first tap dispensed with.

Threading is not done with a die; but it is possible to cut a thread on a lathe providing sufficient care is taken and the tool used is kept very sharp.

The tools to be used for all classes of turning will be the usual high-speed steel, while the spindle speed would depend on the diameter of the Mycalex being turned. The following are usual:

For 1 in. diameter, 120 r.p.m.

For $\frac{1}{2}$ in. diameter, 200 r.p.m.

With cutting speed in each case of 4 in. to 6 in. per minute.

Specimens have actually been turned to a diameter as small as $\frac{1}{32}$ in.

Much experience has shown that the turning of Mycalex on a lathe, unless the result cannot be obtained by any other method, is both expensive and unsatisfactory, and much better results have been obtained by grinding the material wherever possible. So satisfactory indeed has this process been found that all cylindrical work for every purpose is now ground instead of turned.

Strips and Panels

Mycalex can be easily cut with an ordinary engineers hacksaw, but while not recommended for quick production, the best results will be obtained by using a coarse saw blade, with teeth well set, the material to be cut only projecting from the vice about 2 inches. For example—to cut a strip 6 in. long project from the vice about 2 in., cut down to jaw, see that the uncut material



Fig. 4. The finished slab extracted from the melting furnace.

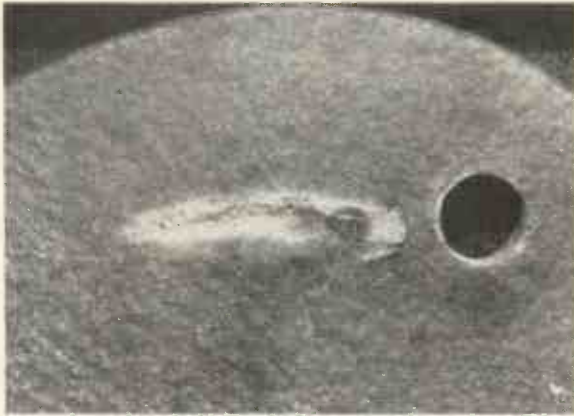

Fig. 10. Effect of arcing on mycalex. The glass has fused to the bead shown on the right of the track. The mica particles are undamaged.

stands out a further 2 in., and repeat until the 6 in. is finished.

A convenient method adopted in the Mycalex Workshops is cutting by bandsaw. Sheets of all thicknesses are cut up in this manner with a saw of 10 to 12 teeth per inch, running at a speed of approximately 1,400 feet per minute. If a bandsaw is not available a milling machine can be used, but this is somewhat expensive.

Moulding

Mycalex can be moulded round metal insets or into various shapes by a form of injection moulding. When metal insets are used, such as the screw thread shown in Fig. 10, the molten material is forced into the die under pressure in a similar manner to die-casting. Valve bases or lamp sockets can be moulded without difficulty, as in Fig. 11. Fig. 12 shows small mouldings for bushes and aerial insulators together with another type of inset for a high tension cable connector. The advantages of Mycalex for the latter are in its ability to withstand high temperature indefinitely without deterioration.

Of the metals used for insets, copper, iron and aluminium are the most satisfactory and make good adhesive joints. Brass does not adhere readily to the material and if it is essen-

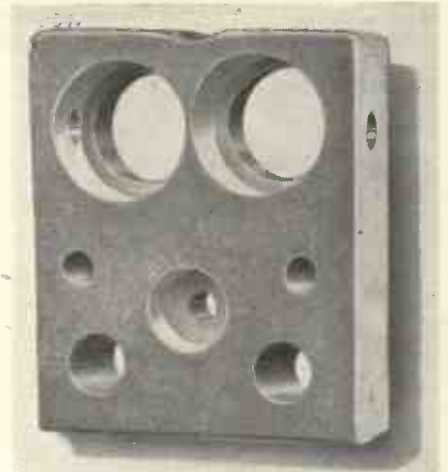

Fig. 6. A slab of Mycalex showing the variety of holes which can be drilled without chipping of the surface.

tial to use it a layer of copper should be deposited first before moulding.

It is also possible to inset Mycalex rod into metal castings to provide an insulating connexion between two metal plates or coil supports. In this case aluminium is recommended as a satisfactory metal, and low melting point alloys (below 700° C.) are first cast in a metal mould and the rod, previously heated to 150° C. inserted.

Properties

As might be expected, the mechanical properties of Mycalex resemble those of glass, but the presence of the mica adds toughness to the material. For example, the bending strength of plate glass is between 200 and 500 kg./sq. cm. against a figure of over 650 for Mycalex. The resistance of the material to weathering is also remarkably high, and the manufacturers have a specimen which has been exposed to the weather for over ten years and which still retains the marks of the saw made at the time it was cut.

The electrical properties depend on the type of glass binder used and on the

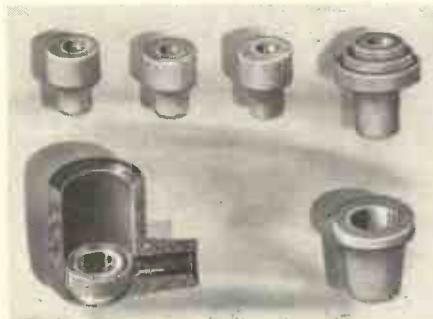

Fig. 9. Moulded aerial bushes and insulators. An H.T. cable connector is also shown.



Fig. 7. Mycalex mouldings. On the left a top cap for valve, on the right a steel thread moulded in mycalex base.

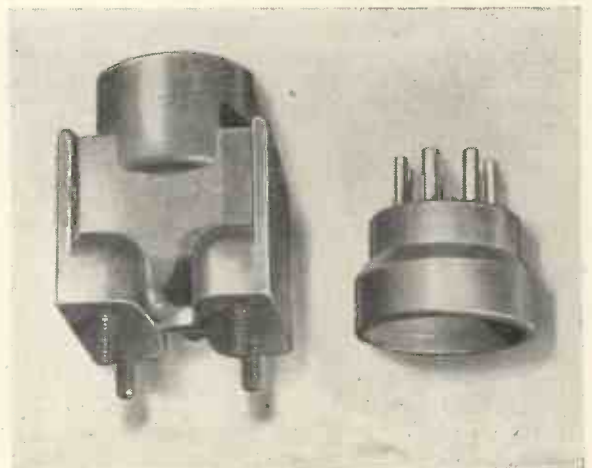

Fig. 8. Mycalex moulded lamp socket and valve base.

PHYSICAL PROPERTIES OF MYCALEX.

ELECTRICAL.

Electric Strength (Breakdown) ...	(Sheet : 550 V./mil for 18 mils. Std. Product : 600 V./mil for 27 mils. Moulded Disk : 200 V./mil for 15 mils.)
All tests at 20° C.	
Surface Breakdown ...	With electrodes 1 1/2 in. apart 25 kV. 1 in. apart 20 kV.
Volume Resistivity*† ...	1 x 10 ¹³ ohms/cm ³
Surface Resistivity*† ...	4 x 10 ¹⁰ ohms/cm ²
Permittivity (K)*§ ...	(Sheet : 6.7
	Std. Product : 6.5
	Moulded Disk : 10.4
Power Factor (tan δ)*§... ...	(Sheet : .0070
	Std. Product : .011
	Moulded Disk : .02

* at 17°C † Humidity 60% § Frequency 1 kc/sec.

(The inherent power factor of Mycalex is consistently of the order of .005 to .009 at 800 c.p.s. and .002 at 1,000 Kc/s. without particular reference to temperature and humidity.)

MECHANICAL PROPERTIES.

Specific Gravity ...	2.45
Water Absorption ...	0—.02%
Oil Absorption02%
(After 48 hrs. immersion.)	
Tensile Strength... ...	{ Sheet : 5,800 lbs./sq. in. Std. Product : 8,000 lbs./sq. in.
Transverse Strength—Modulus of Rupture ...	9,370 lbs./sq. in.
Bending Strength—Modulus of Rupture ...	9,670 lbs./sq. in.
Compression Test ...	13,500 lbs./sq. in.
(Mean for a minimum of three samples.)	
Crushing Load ...	17.5 tons/sq. in.
Hardness—(Brinell) ...	37—47
(Scleroscope) ...	40
Resistance to Impact (VDE) ...	4—7

THERMAL PROPERTIES.

Coefficient of Expansion—At 0° to 30° C.0000095
	From 30° to 50° C. .0000088
Plastic Yield (Martens Test) ...	450° C.
Resistance to Arcing (VDE Test) ...	3.



Fig. 5. Photomicrograph of Mycalex sheet showing uniform distribution of mica particles.

mica. The table given in the adjoining column is based on tests by various authorities and is for British made Mycalex. Figures for the American type differ in some respects for the reasons given above.

A valuable property of the material is that it does not char on flashover or arcing. If the temperature produced by the discharge is sufficiently high the glass on the surface melts and remains as a bead in the path of the discharge, the mica particles underneath being undamaged. This is shown in Fig. 13, which is an enlargement of the track of a discharge.

The photographs illustrating this article were taken by the courtesy of Sir Herbert Ingram, Chairman of the Mycalex Parent Co., with whose permission this account of a unique and important insulating material is given.

A Note on RC Oscillators

by D. G. TUCKER, B Sc., (Eng), A.M.I.E.E.

IN an article in this journal for April, 1942—"A Simple RC Oscillator," by W. Bacon—some information is given on a one-valve RC oscillator, which can be amplified in two respects as follows:

(1) The RC network for the oscillator need not be limited to four sections and actually any number of sections from three upwards may be used. A point here is that the attenuation of the network at the frequency at which the necessary 180° phase shift is obtained decreases as the number of sections is increased; thus a larger number of sections enables a lower gain valve to be used.

(2) An oscillator depending only on resistance and capacity for tuning certainly has the advantage of improved stability over an inductance-capacity tuned oscillator, but this is only true with regard to temperature variations, and even in this case it is to be noted that inductors for frequencies down to about 500 c/s. can be made with a temperature coefficient very little worse than that of a good wire-wound resistor. With regard to supply voltage variations, the RC oscillator is much inferior.

Tests made on an RC oscillator show

that the frequency change is 0.2 – 0.8 per cent. compared with 0.05 per cent. in an LC oscillator (Q approx. 40) for a change in H.T. voltage from 130 – 120 v.

For a heater change from 4.5 to 3.5 v. the RC oscillator altered by 2.2 per cent. for no measurable change in the LC oscillator.

In these tests, the gain of the circuit was adjusted so that oscillation took place on the lowest voltage with a small margin only (about 1 db)—the best results are obtained in this way.

The RC oscillator is unstable because the impedance of the valve and its load, regarded as a generator, is effectively in series with the phase-shifting network, and can thus affect the phase-frequency characteristic of the network. It is for this reason that the R value should be high in comparison with the valve generator impedance, and not merely to avoid loading the valve. It is interesting to note, however, that no advantage is gained by making R much higher than about 150,000 ohms, because it is not reasonable to make resistors of Eureka wire above this value owing to its comparatively low resistivity, and materials such as nichrome, which are

much more suitable for high values, have a very inferior temperature coefficient. Thus, what may be gained on voltage stability will be lost on temperature stability. Only wire-wound resistors will be suitable in any case if good stability is required.

In spite of these disadvantages, the RC oscillator is, a very useful one for low frequencies, where inductor design is difficult, and a circuit for a 50 c/s oscillator was made by the present writer to give a reasonable good performance. Voltage stability is obtained by using a neon stabiliser for the H.T. and a barretter for the heater circuit. The anode of a SP41 valve had 15,000 ohms anode load and the RC network consisted of three sections of 0.01 μF and 100,000 ohms each. The oscillator was coupled to a buffer amplifier (another SP41) through 1 μF with a 1 megohm grid leak. Choke decoupling was used in both valves.

It is always desirable to use a buffer output amplifier to make the frequency independent of the load and to enable a reasonable power to be obtained. The stability obtained is about 0.1 per cent. change of frequency for either a voltage variation of 10 per cent. or a temperature variation of 10° C.

X-Ray Analysis in Industry

Conference Organised by the Institute of Physics

In view of the growing importance of X-ray analysis in solving certain industrial problems, the Institute of Physics decided in 1939 to hold a conference with the object of interchanging ideas and practical experiences among those engaged in research in this important subject.

The outbreak of war unfortunately compelled the postponement of the conference till the following year and in 1940 the outlook was so uncertain that a second postponement was reluctantly made.

The subject matter of the papers to be presented, was, however, published in May, 1941¹ and the discussions on them finally took place on April 10 and 11 at the Cavendish Laboratory, Cambridge, where over 250 physicists assembled under the presidency of Sir Lawrence Bragg, O.B.E., F.R.S.

Under existing conditions the discussions and a description of the exhibition of apparatus (which was held at the same time) may not be published but it is hoped that edited notes may be available at a later date.

THE earliest application of X-ray analysis was in the study of crystalline structure, *i.e.*, the pattern of the atomic arrangement in the perfect crystal. If a beam of X-rays is passed through a crystal, each unit of the structure scatters a small fraction of the incident radiation and this scattered radiation will in certain directions add up to produce an intense beam. In other directions, depending on the pattern of the structure, there will be no appreciable scattering. The crystal behaves, in effect, as a three dimensional diffraction grating, producing a spectrum in those directions in which the path difference between the wavelengths scattered by adjacent units is an integral number of wavelengths.

It is well known that an optical grating will only give diffraction effects when the spaces are of the same order of magnitude as the wavelength involved. In the case of the crystal the grating spaces are of the order of a few Angstrom units (10^{-8} cm.) which is comparable to the wavelength of X-rays. Diffraction spectra are therefore readily obtained.

In the original method of observing the diffraction devised by Laue,² a narrow beam of X-rays is passed through a slice of the crystal and falls on a photographic plate. On development the spot formed by the direct beam is seen to be surrounded by a series of diffraction spots corresponding to the reflexion of the incident beam by the lattice unit planes of the crystal. Sir W. L. Bragg showed that if the beam strikes the planes at an angle θ (Fig. 1) the path difference between reflexions from successive planes is $ND = 2d \sin \theta$.

If an appreciable refracted beam is to be formed the waves reflected from successive lattice planes must be in phase, or $2d \sin \theta = m\lambda$ where λ is the wavelength of the X-rays and m is an integer.

In Laue's method, X-rays with a continuous range of wavelengths were used and each set of planes reflected the appropriate wavelength to fulfil the equation above.

X-Ray Spectrometer.

In Sir W. H. Bragg's X-ray spectrometer⁴ use was made of the homogeneous rays of characteristic wavelength, which were first discovered by this instrument. The crystal is mounted on a spectrometer table and oriented so that a required set of lattice planes is

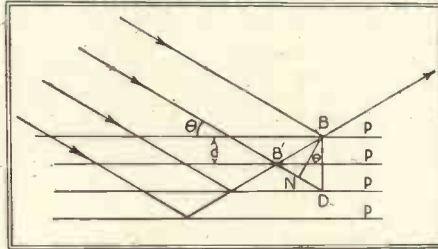

parallel to the axis of rotation. X-radiation from a slit aperture is passed through the crystal which is then rotated until the equation above is satisfied. The reflected beam is detected and measured by means of an ionisation chamber and the successive orders of reflexion corresponding to ascending values of m are found.

Other Methods of Analysis.

If the material to be investigated is not in the form of a well-defined crystal or is otherwise inconvenient to handle by the foregoing method, a mass of crystalline powder is mounted on a hair in the centre of a hollow cylindrical box which has a photographic film fixed round its inner periphery. The material may be either ground into powder or in its natural form. We now have a random arrangement of particles which produce reflexion from all the crystal planes and the developed film shows a series of lines which correspond to each reflecting lattice plane. This method was first used by Debye and Scherrer⁵ and Hull⁶ but is limited if the structure is complex.

Schiebold⁷ proposed to rotate the crystal about an axis parallel to one of the crystal axes, the beam being directed in a line at right angles to the axis of rotation. As the crystal rotates each set of planes in turn fulfils the conditions of the equation and a spot pattern is made on a photographic film perpendicular to the incident beam.

Deductions from Analysis.

Since diffraction effects may be produced by an infinite number of arrangements of the scattering matter, the deductions drawn from examination of the refraction photographs must be largely a matter of intelligent trial and error and correlated evidence must be added before a definite conclusion about the structure of the substance is reached.

Apart from its atomic pattern, a crystalline material has many characteristics, such as crystal size, shape,

orientation, state of perfection, and internal strain, which has a profound influence on its mechanical and other properties. X-ray analysis measures such characteristics, and is consequently an important aid in an industrial laboratory. The main concern of the conference was with the technique of such analysis and its results.

Applications to Electronics.

H. P. Rooksby⁸ has recently investigated the nature of the coating on thermionic cathodes by the powder method and has compared the X-ray patterns of a barium and strontium carbonate mixture and a solid solution containing 50 per cent. (molecular) of barium carbonate.

It is shown that when the final coating contains a solid solution of BaO/SrO the emission is higher than when they are formed from a BaCO₃-SrCO₃ mixture. Maximum thermionic activity is always associated with a single-phase type of oxide and to ensure this the carbonates must be applied in the form of a solid solution.

X-ray examination also shows that during life reduced emission is accompanied by a loss of BaO, the actual change in the oxide coating being shown by a movement of the diffraction lines towards the position of pure strontium oxide.

In fluorescent materials for cathode-ray tube screens the presence of minute traces of impurity ("activator") in the phosphor is known to increase the efficiency of the material considerably—in fact some materials only become luminescent in the presence of such impurities. The position of this impurity in the lattice structure of the phosphor can be demonstrated by X-ray analysis and it has been shown for manganese activator that it does in fact substitute for atoms of the main lattice.⁹ The addition of manganese to zinc orthosilicate expands the lattice by a measurable amount and the phosphor is in effect a solid solution of manganese orthosilicate in zinc orthosilicate. The X-ray analysis of phosphors has in some cases proved so accurate that it is used for production checking of compounds, and if new fluorescent materials are to be blended the X-ray method enables the composition of each phase to be measured separately whereas the determination of the composition by other methods is almost impossible.

Diffraction Photographs and how they are produced.

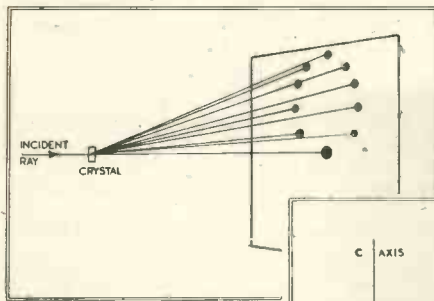

Laue photograph of benzil (right), using radiation from a copper target. The diagram on the left shows how the spots are produced by reflexion at the planes around a crystal zone.

(Photo: by courtesy of the Institute of Physics).

Photograph of urea nitrate taken by the rotation method (below). (Right), Layer lines of a rotation photograph on a flat plate.

(Photo: by courtesy of the Institute of Physics).

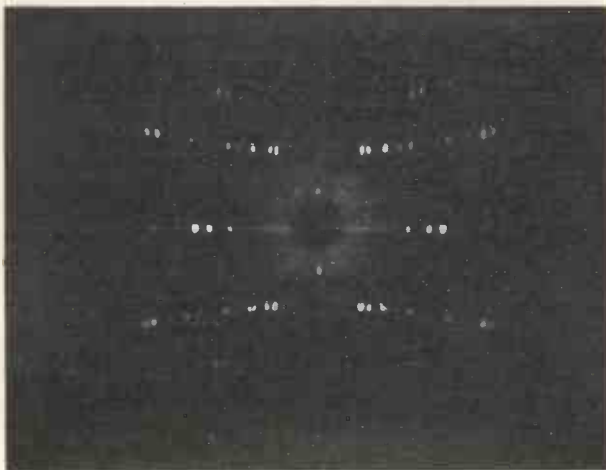
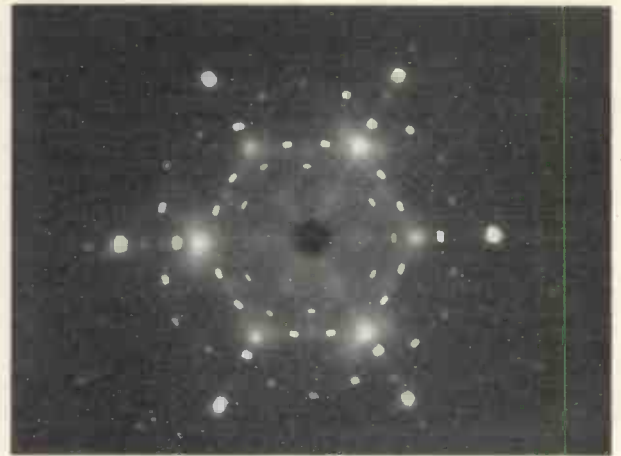
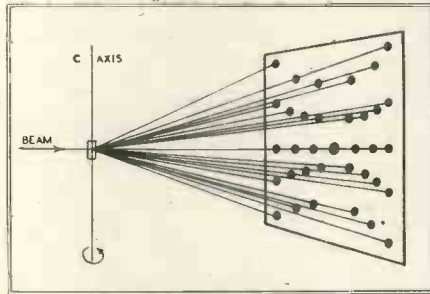

(Right). Patterns obtained on a flat plate, and on a film arranged round the periphery of the camera with the crystal at the centre. The photograph below shows a spectrograph of long-chain paraffin taken by this method.

(Photo: by courtesy of Dr. K. Lonsdale, R.I.).

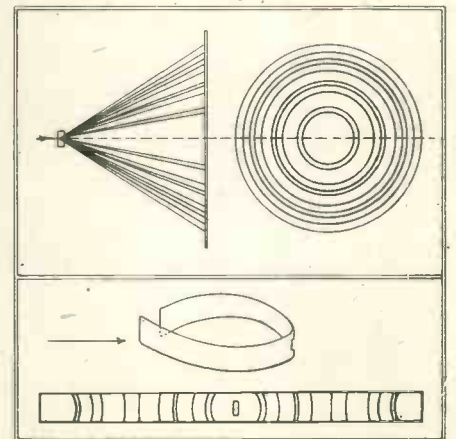

Sir W. L. Bragg's Address.

In his address to the conference on the opening night, Sir Lawrence Bragg, President of the Institute of Physics, traced the development of X-ray analysis from the original experiments by Laue, his own interpretation of them in terms of reflexion by the crystal structure, and his father's early work on the X-ray spectrometer. During the first two years he and his father collaborated in the work on the structure of various crystals and in the improvement of technique. In 1921 Sir Wm. Bragg opened a new field with his work on organic crystals — naphthalene and anthracene. Lantern slides showed an interesting comparison between some early results and those obtained with modern apparatus and refinements.

In dealing with the present and future of X-ray analysis, the president pointed out that in conjunction with the electron microscope the diffraction method covered the whole field of microscopy from the visible region to the atom.

He saw as one main field the extension of X-ray analysis to highly complex organic compounds whose structure had not yet been elucidated by classical chemical methods.

A new field which is hardly yet explored is that of sub-microscopic structures within metals such as occur in age-hardening and which profoundly affect the physical properties.

Further scope for X-ray analysis is in biochemistry, in which investigations have already been made on the composition of hæmoglobin and the vitamins.

The arrangements were in the hands of Dr. Lang, the Secretary of the Institute of Physics and Dr. Sykes, the organising secretary of the conference and at the conclusion of the meeting appreciation was expressed for their efforts in making it a success.

REFERENCES.

- ¹ *Jour. of Sci. Inst.*, Vol. 18, Nos. 5 and 7.
- ² Laue, *Bayerischen Akademie der Wissenschaft, June, 1912.*
- ³ Bragg, *Proc. Camb. Phil. Soc.*, Vol. 27, Pt. 1.
- ⁴ Bragg, *Proc. Roy. Soc.*, (A) Vol. 89, p. 468.
- ⁵ Debye and Scherrer, *Phys. Zeit.*, Vol. 17, 1916, p. 277.
- ⁶ Hull, *Phys. Rev.*, Vol. 10, 1917, p. 661.
- ⁷ Polanyi, *Naturwiss.*, Vol. 9, 1921, p. 337.
- ⁸ Rooksby, *Jour. Sci. Inst.*, Vol. 18, No. 5, p. 84.
- ⁹ Jenkins, McKeag and Rooksby, *Nature*, 143, p. 978.

Frequency Modulation

Part VII.—Frequency Modulated Reception (Concluded)

by K. R. STURLEY, Ph.D., A.M.I.E.E.

NO frequency modulated broadcast transmission has yet been sanctioned in this country, and the circuit diagram of the frequency modulation receiver should be regarded only as a prototype, for the author has had no opportunity of carrying out exhaustive tests upon it with standard transmissions.

The circuit diagram is in the nature of a summary of the design procedure outlined in the previous series of six articles, and to complete the analysis the method of calculating the component values is briefly indicated below. The receiver is assumed to have preset signal circuits, tuned to a central frequency of 45 Mc/s, and having a pass band from 43 to 47 Mc/s. An intermediate frequency of 4.5 Mc/s is employed.

1. The Aerial Input Circuit

The details of the aerial input circuit are as follows:

- Radiation resistance of dipole aerial. = 80Ω
- Characteristic impedance of the feeder to match with the aerial. = 80Ω
- Total inductance of the centre tapped coil L_1 (any suitable value preferably less than L_2 may be chosen). = 0.28μH
- Total capacitance across the secondary coil; this is the sum of C_1 , the valve, wiring, and coil self capacitances. (20 μμF is suggested in the February article, but this is too low for the high g_m R.F. valve, Z62, which has a high input capacitance). = 30 μμF
- Total inductance of the secondary coil, L_2 . = 0.416 μH
- Undamped Q of the secondary circuit, Q_0 . = 150
- Grid input resistance (R_{g1}) of the R.F. valve, Z62, at 45 Mc/s. = 3,000Ω
- Total equivalent series R_{2s} of the secondary circuit, including the valve grid input resistance. = 0.785 + 4.62
- $\frac{\omega L_2}{Q_0} + \frac{\omega^2 L_2^2}{R_{g1}}$ = 5.405Ω
- The Q of the secondary circuit damped by the valve resistance R_{g1} = $\frac{\omega L_2}{21.75}$

Optimum coupling between the feeder and secondary circuit calls for the following value of mutual inductance M_1 * between L_1 and L_2 .

$$M_1 = \frac{Z_{a1}}{\omega} \sqrt{\frac{R'_{2s}}{R_{a1}}}$$

where Z_{a1} = total impedance of the primary circuit = $\sqrt{R_{a1}^2 + X_{a1}^2}$ and R_{a1} = characteristic impedance of the feeder

$$X_{a1} = \omega L_1 = 6.28 \times 45 \times 0.28 = 79\Omega$$

$$\therefore Z_{a1} = \sqrt{80^2 + 79^2} = 112.3\Omega$$

$$\therefore M_1 = \frac{112.3}{6.28 \times 45} \sqrt{\frac{5.405}{80}} = 0.104 \mu H$$

If the coils L_1 and L_2 are wound on a $\frac{1}{2}$ inch diameter former with 16 S.W.G. at 10 turns per inch, the total number of turns are approximately 4 and 6 respectively.

Owing to optimum coupling the overall Q of the tuned secondary circuit is halved, i.e., is 10.87, so that the band width (over which the loss does not exceed 2 db) is

$$\Delta f = \pm f_r / 2Q = \pm \frac{45}{21.75} = \pm 2.07 \text{ Mc/s,}$$

and this satisfies the requirement for preset signal tuning.

Optimum coupling gives a voltage step-up from the feeder to grid of V_1 and the expression* is

$$\text{Amplification} = \frac{M_1}{0.104 \times 10^{-6} \times 2C_{1T}Z_{a1}R'_{2s}} = 2.85$$

$2 \times 30 \times 10^{-12} \times 112.3 \times 5.405$
A.V.C. is not applied to V_1 since change of signal grid bias affects the grid input resistance and capacitance, thus varying the band width and tuning of the secondary circuit. There is a decrease of about 4 μμF in the grid input capacitance from normal to maximum negative bias, and the operating input capacitance is of the order of 15 μμF. Wiring and coil (L_2) self capacitance account for about 5 μμF so that capacitance C_1 requires to be about 10 μμF.

2. The Anode Circuit of the R.F. Valve V_1

The preset signal circuit leading to the frequency changer may be inserted in the anode of the R.F. valve, and coupled by capacitance and grid leak to the grid of V_2 . This has the advantage of simplicity and generally highest stage gain from the grid of V_1 to the

grid of V_2 , but it has the serious disadvantage of high "stray" capacitance, since there are two valve capacitances (from V_1 and V_2) across the tuned circuit. This can be mitigated by using a smaller inductance for the signal coil, or by using transformer coupling. The former is the simpler solution, for it is difficult to obtain a very high mutual inductance between the primary and secondary of the transformer. Thus the value of L_2 is selected to be 0.28 μH, which gives a total tuning capacitance of 44.5 μμF. Of this total, approximately 15 μμF is contained in the grid input capacitance of the frequency changer, 10 μμF in the anode output capacitance of the R.F. valve, and 5 μμF in stray and coil self capacitance, leaving a capacitance for C_4 of approximately 15 μμF. The resistance R_4 is the grid leak of the frequency changer valve, and it also acts as the damping resistance for providing the wide pass band. Its value is calculated as follows: we will assume that the undamped circuit Q_0 is 150, as for the aerial circuit, that the frequency changer grid input resistance is the same as that of the R.F. valve, viz., 3,000Ω (this is very nearly so because the valve is a hexode), and that the internal slope resistance of the R.F. valve can be neglected. The overall Q_d of the damped circuit is therefore given by

$$Q_d = \frac{\omega L_2}{\omega L_2 / Q_0 + (\omega L_2)^2 / 3,000} = 30.4$$

$1/Q_0 + \omega L_2 / 3,000 = .0066 + .0263$
To reduce Q to $Q_T = 11.25$, the value required for a pass-band of ± 2 Mc/s., the resistance R_4 is

$$R_4 = \frac{\omega L_2 Q_d Q_T}{Q_d - Q_T} = \frac{19 \times 30.4 \times 11.25}{18.15} = 1485\Omega$$

The mutual conductance of the R.F. valve, Z62, is 7.5 mA/volt, and the resultant dynamic impedance of the anode tuned circuit is $\omega L_2 Q_T = 890\Omega$.

The amplification from the grid of V_1 to the grid of V_2 =

$$7.5 \times 10^{-3} \times 890 = 6.67$$

3. The Oscillator Circuit

A separate triode valve is employed as it is generally more stable and easier to maintain in oscillation than the triode section of the triode-hexode. The anode of the triode section of V_2 is returned to cathode. The electron coupled form of oscillator is employed because it is easy to oscillate, negative feedback, due to the portion of the tuning coil between cathode and earth, assists amplitude and frequency stability, and one side of

* Receiver Aerial Coupling Circuits, K. R. Sturley, *Wireless Engineer*, April (1941) page 137.

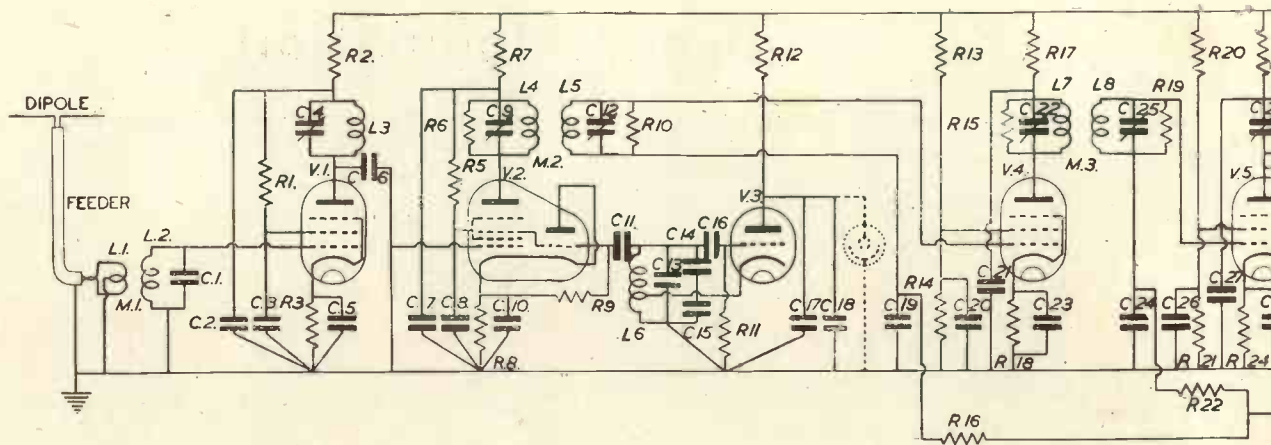

FREQUENCY MODULATION RECEIVER

Values of Components

Resistances (in ohms).

R 1	50,000
R 2	1,000
R 3	200
R 4	1,485
R 5	25,000
R 6	18,000
R 7	1,000
R 8	250
R 9	50,000
R 10	18,000
R 11	50,000
R 12	30,000
R 13	30,000
R 14	20,000
R 15	39,200
R 16	0.1 meg.
R 17	1,000
R 18	300
R 19	39,200

R 20	30,000
R 21	20,000
R 22	0.1 meg.
R 23	1,000
R 24	300
R 25	14,500
R 26	0.25 meg.
R 27	30,000
R 28	20,000
R 29	0.25 meg.
R 30	1,000
R 31	39,200
R 32	300
R 33	0.1 meg.
R 34	182,000
R 35	40,000
R 36	10,000
R 37	44,000

R 38	13,800
R 39	0.1 meg.
R 40	0.1 meg.
R 41	0.2 meg.
R 42	0.5 meg. (var.)
R 43	10,000
R 44	0.1 meg.
R 45	2,000
R 46	2,000
R 47	0.1 meg.
R 48	10,000
R 49	0.5 meg.
R 50	10,000 (var.)
R 51	0.5 meg.
R 52	100
R 53	100
R 54	180
R 55	180

Capacitance

C 1	10 $\mu\mu\text{F}$ (approx.)
C 2	0.01 μF
C 3	0.01 μF
C 4	15 $\mu\mu\text{F}$ (approx.)
C 5	0.01 μF
C 6	100 $\mu\mu\text{F}$
C 7	0.01 μF
C 8	0.01 μF
C 9	20 $\mu\mu\text{F}$ (fixed) and 30 $\mu\mu\text{F}$ (max. variable, air)
C 10	0.01 μF
C 11	50 $\mu\mu\text{F}$
C 12	20 $\mu\mu\text{F}$ (fixed) and 30 $\mu\mu\text{F}$ (max., variable, air)
C 13	7 $\mu\mu\text{F}$
C 14	30 $\mu\mu\text{F}$
C 15	20 $\mu\mu\text{F}$ (max., variable, air)
C 16	50 $\mu\mu\text{F}$
C 17	0.01 $\mu\mu\text{F}$
C 18	16 μF (electrolytic)

the tuning capacitance, C_{15} , can be earthed. The inductance of the coil L_6 is 0.416 μH , and the cathode tapping on this 6 turn coil occurs at approximately 2 turns up from the earthed end. The tuning capacitance is made up of the grid input capacitance of V_2 and V_3 (about 17 $\mu\mu\text{F}$), wiring and coil self capacitance (about 5 $\mu\mu\text{F}$), the fixed capacitor C_{13} (7 $\mu\mu\text{F}$), and the series combination of C_{14} and C_{15} . C_{14} is a fixed capacitor of 30 $\mu\mu\text{F}$ restricting the range of C_{15} , a variable air dielectric capacitor with ceramic insulating supports and a maximum and minimum value of 20 and 5 $\mu\mu\text{F}$ respectively. The oscillator frequency—in order to obtain greatest stability—is selected to be lower than the signal frequency, and variation of C_{15} then covers the desired frequency range from 38.5 to 42.5 Mc/s.

Constant H.T. supply is an essential requirement for frequency stability and two decoupling capacitors are used from the anode of V_3 to earth. C_3

bypasses radio frequencies and C_{18} any audio or hum voltages in the H.T. supply. Better H.T. regulation can be obtained with a gas filled device such as a neon tube (shown dotted in the diagram), and then C_{18} becomes unnecessary. R_{12} must be reduced to about 10,000 Ω .

4. Intermediate Frequency Amplification

Details of the design of the intermediate frequency amplifier were given in the fifth article (March, 1942). We will only state the values of the inductances and capacitances, and show the method of calculating the damping resistances required to provide the bandwidth of ± 100 kc/s. at the intermediate frequency of 4.5 Mc/s.

(a) The first I.F. transformer in the anode of the frequency changer valve V_2 .

Total inductance of primary or secondary (L_4 and L_5) = 25 μH .

Total capacitance of primary or secondary = 50 $\mu\mu\text{F}$.

Required Q for ± 100 kc/s band width = 22.5.

Mutual inductance between L_4 and L_5 , $M_2 = 1.11 \mu\text{H}$.

If the initial Q of the undamped primary or secondary is $Q_0 = 150$, the equivalent parallel resistance of either circuit is $\omega L_4 Q_0 = 106,000\Omega$. Assuming the grid input resistance of the next valve V_3 can be neglected.

The extra damping resistance (R_6 and

$$R_{10}) \text{ required} = \frac{106,000 \cdot Q_T}{Q_0 - Q_T}$$

$$= \frac{106,000 \times 22.5}{150 - 22.5}$$

$$= 18,700\Omega.$$

The amplification of the frequency changer V_3 when $g_c = 0.3$ mA/volt

$$= \frac{g_c \omega L_4}{2}$$

$$= 2.385$$

A.V.C. is not applied to the frequency

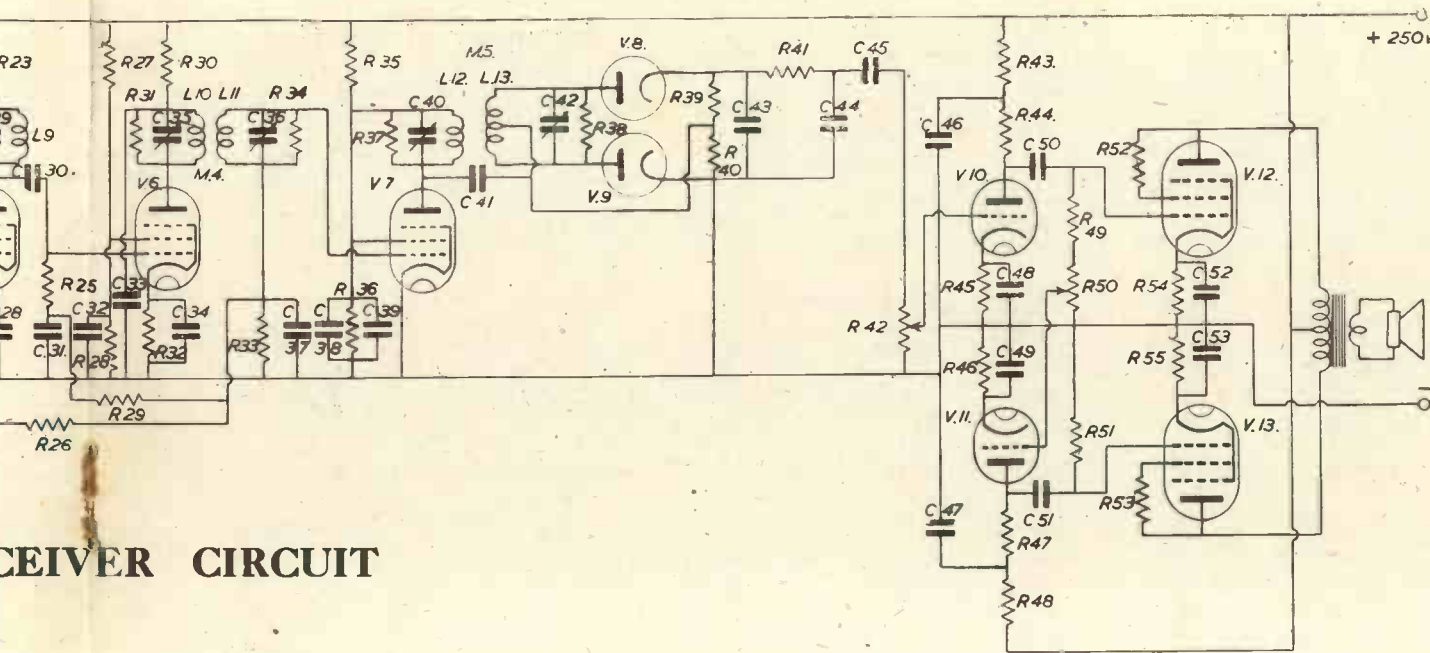

RECEIVER CIRCUIT

es.

C19	.001 μF
C20	0.1 μF
C21	0.1 μF
C22	20 μμF (fixed) and 30 μμF (max., variable, air)
C23	0.1 μF
C24	0.001 μF
C25	20 μμF (fixed) and 30 μμF (max., variable, air)
C26	0.1 μF
C27	0.1 μF
C28	0.1 μF
C29	30 μμF (fixed) and 30 μμF (max., variable, air)
C30	500 μμF
C31	.001 μF
C32	0.1 μF
C33	0.1 μF
C34	0.1 μF
C35	20 μμF (fixed) and 30 μμF (max., variable, air)

C36	20 μμF (fixed) and 30 μμF (max., variable, air)
C37	100 μμF
C38	0.1 μF
C39	8 μF (electrolytic)
C40	70 μμF (fixed) and 30 μμF (max., variable, air)
C41	50 μμF
C42	70 μμF (fixed) and 30 μμF (max., variable, air)
C43	50 μμF
C44	100 μμF
C45	0.05 μF
C46	2 μF
C47	2 μF
C48	25 μF (electrolytic)
C49	25 μF (electrolytic)
C50	0.05 μF
C51	0.05 μF
C52	25 μF (electrolytic)
C53	25 μF (electrolytic)

Inductance (microhenries).

L 1	0.28
L 2	0.416
L 3	0.28
L 4	25
L 5	25
L 6	0.416
L 7	25
L 8	25
L 9	19.35
L10	25
L11	25
L12	12.5
L13	12.5

Valves.

V 1	Marconi	Z62
V 2	"	X65
V 3	"	H63
V 4	"	KTW63
V 5	"	KTW63
V 6	"	KTW63
V 7	"	KTZ63
V 8	"	D63
V 9	"	D63
V10	"	H63
V11	"	H63
V12	"	KT66
V13	"	KT66

Mutual Inductances.

M 1	0.104
M 2	1.11
M 3	1.235
M 4	1.235
M 5	0.384

changer valve V₂ because variation of signal grid bias varies the input resistance and capacitance of signal and oscillator grids, causing variation of tuning and damping and, most serious of all, change of oscillator frequency.

(b) The second I.F. Transformer.

This is an overcoupled transformer (Q_k = 2) with nearly twice the Q of the transformer in the frequency changer anode circuit. The inductance and capacitance values are the same as for the first transformer.

The required Q = 40.5

Mutual inductance between L₇ and L₈, M₃ = 1.235 μH*

Extra damping resistance

$$\omega L_7 Q_0 Q_{IT}$$

$$(R_{15} \text{ and } R_{19}) = \frac{\omega L_7 Q_0 Q_{IT}}{Q_0 - Q_{IT}}$$

$$= \frac{106,000 \cdot 40.5}{150 - 40.5}$$

$$= 39,200\Omega$$

* A misprint in the March issue gave M₃ as 1.11.

The double humped frequency response of this transformer has a trough at 4.5 Mc/s, 2 db below the peak, hence the amplification of valve V₄ at 4.5 Mc/s

$$= \frac{g_{m\omega} L_7 Q_T}{2 \times 1.26} \cdot \frac{-2\text{db} = 1/1.26}{1.5 \times 10^{-3} \times 28,700} = 17.1$$

A.V.C. is applied to the valve V₄, as the input resistance and capacitance change resulting from signal grid bias variation is designed to be small. The A.V.C. decoupling capacitor C₁₉ is smaller than its counterpart in the amplitude modulation receiver since undesired amplitude change of the frequency modulated carrier, when fed back along the A.V.C. line, tends to cancel the amplitude variation of the carrier. It is in fact a form of negative feedback.

(c) The isolator stage.

An isolator stage is necessary in the I.F. amplifier to reduce the regenerative and degenerative effect of the anode-grid capacitance of the I.F. valves. Its single tuned circuit component values are.

Total inductance L₀ = 19.35 μH

Total capacitance = 64.5 μμF

Required dynamic resistance of circuit = 12300Ω

Extra damping resistance R₂₅

$$= \frac{\omega L_0 Q_0 \times 12,300}{82,000 \times 12,300} = 14,500\Omega$$

$$= \frac{69,700}{(KTW63) = g_m R_D} = 18.45$$

Amplification of valve V₅ (KTW63) = g_mR_D = 1.5 × 10⁻³ × 12,300 = 18.45

(d) *The last I.F. amplifier stage.*

This is identical with the 1st amplifier stage (valve V_4 and the second I.F. transformer), except that the limiter stage, which follows, reflects a load on to the secondary of the transformer, necessitating an increase in the secondary damping resistance R_{34} . Damping due to grid current in the limiter valve V_7 can be taken as half the D.C. load resistance, viz., $\frac{1}{2}R_{33} = 50,000\Omega$. The required total secondary damping resistance = $39,200\Omega$

$$\begin{aligned} \text{Extra damping resistance } R_{34} &= \frac{39,200 \times 50,000}{50,000 - 39,200} \\ &= 182,000\Omega \end{aligned}$$

(e) *The limiter stage.*

The resistance R_{33} and capacitance C_{37} provide self bias for the limiter valve V_7 , which takes grid current. The combination of grid current bias and low anode and screen voltage provides the limiting action to suppress amplitude modulation. The resistance R_{35} and R_{36} act as a potentiometer to reduce screen and anode voltages to approximately 40 volts. C_{35} is a large decoupling capacitor ($8 \mu F$) to bypass the low frequency components of any amplitude modulation present at the grid of the limiter valve.

The limiter anode circuit contains the phase discriminator for changing the frequency modulation into amplitude modulation.

Details of the component values for the phase discriminator have been given in the last issue (April, 1942) and were as follows:

- Total inductance of primary or secondary (L_{12} and L_{13}) = $12.5 \mu H$.
- Total capacitance of primary or secondary = $100 \mu F$.
- Required $Q = 27.9$.
- Mutual inductance between L_{12} and L_{13} , $M_6 = 0.384 \mu H$ $k = 0.856$.

The primary circuit is already damped by the two diodes (V_8 and V_9) in parallel, i.e., by $\frac{1}{2}R_{30}$, and the load resistances in parallel, i.e., $\frac{1}{2}R_{30}$, so that it has a detection circuit damping resistance of $R_{30}/6 = 16,666\Omega$. If $O_0 = 150$, to reduce the overall Q to 27.9 requires a total damping resistance of

$$\begin{aligned} \frac{\omega L_{12} \times 150 \times 27.9}{150 - 27.9} &= 12,100\Omega \\ \text{extra damping resistance, } R_{37} &= \frac{16,666 \times 12,100}{4566} \\ &= 44,000\Omega \end{aligned}$$

The damping resistance across the secondary due to detection is equal to $R_{37} = 0.1 M\Omega$, and the total required damping resistance is again $12,100\Omega$, hence extra damping resistance, R_{38}

$$\begin{aligned} &= \frac{12,100 \times 100,000}{87,900} \\ &= 13,800\Omega \end{aligned}$$

5. **The Detector Stage**

Little comment is needed on the detector stage, the resistance R_{41} and capacitance C_{44} act as an R.F. filter between the detector output and first A.F. valve. If pre-emphasis (increased amplification of the high audio frequencies contained in the modulation) is used at the transmitter, C_{44} is increased to $.0005 \mu F$ in order to obtain de-emphasis at the receiver.

6. **The Audio Frequency Amplifier**

The push-pull output stage necessitates either a transformer, with a centre tapped secondary, in the output of the A.F. valve, or an extra phase reversing valve. The latter method is adopted in this receiver on the score that RC coupling gives better frequency response than transformer coupling.

The second A.F. amplifier valve, V_{11} , acts simply as a phase reverser, and its input voltage is derived from a potentiometer across the output of the first valve V_{10} . The degree of tapping-down is equal to the amplification of V_{10} , and the resistances R_{49} and R_{50} are calculated as follows:

$$\begin{aligned} \text{Slope resistance of } V_{10} \text{ (H63)} &= 66,000\Omega \\ \text{Amplification factor} &= 100 \\ &= \frac{100 \times 100,000}{100,000 + 66,000} \\ \text{Stage gain of } V_{10} &= 60 \end{aligned}$$

$$\text{Ratio of } \frac{R_{50}}{R_{49} + R_{50}} = 1/60$$

In the circuit diagram R_{50} is $10,000\Omega$ and variable, so that a maximum ratio of $1/51$ is obtainable. The correct position on R_{50} can be found by inserting a transformer in the H.T. lead from the centre tap of the output transformer primary. Phones across the secondary of the first transformer in the H.T. lead give minimum volume when the tapping point on R_{50} is correctly adjusted.

7. **The Output Stage**

This uses two tetrodes (KT66), triode connected, to act as push-pull triode valves. The resistances R_{52} and R_{53} , in the screen circuits, guard against high frequency parasitic oscillation, to which push-pull circuits are often very prone. A common bias resistance equal to $\frac{1}{2}R_{54}$ may be used for the two valves if desired, and this has the advantage of reducing hum and audio frequency negative feedback in the cathode circuit. The disadvantage is that independent bias adjustment for matching the valves is not possible. If separate bias resistances are used, matching is performed by adjusting one bias resistance to give minimum volume in phones connected to a transformer in the H.T. lead to the centre tap of the output transformer.

The anode-to-anode load for the two KT66 valves in push-pull is $2,500\Omega$, so that a step-down transformer ratio of approximately 13 to 1 is required if the loudspeaker speech coil impedance is 15 ohms.

Frequency Modulation. Corrections.

We regret that some errors—mainly typographical—have occurred from time to time in this series of articles.

A complete list appears below, and readers are asked to correct their original copies accordingly.

Part 3, p. 585, col. i.

Multiplication sign omitted between $\left(1 + \frac{L}{L_2}\right)^{\frac{1}{2}}$ and $\left(1 + \frac{L}{L_1}\right)^{-\frac{1}{2}}$ in the line below it in Equation 8.

Addition sign missing between Z_1 and Z_2 in the denominator of the first expression of Equation 9, which should read: $g_m E_a Z_2$

$$\frac{Z_1 + Z_2}{E_a}$$

The denominator in the last expression should read: $1 + (R \omega C)^2$.

Part 3, p. 585, col. iii.

"reactance value" should read "reactance valve."

Part 4, p. 629, col. i.

Add footnote:

The insertion of a series resistance in the cathode lead to reduce grid circuit damping from the valve requires a small capacitance (about 5 mmfd.) from cathode to earth in order to be effective.

Part 5, p. 683, col. i.

Sign of equality omitted between G_0 and I of Equation 4.

$$g_m \omega C_{ga} \quad g_m \omega C_{ga} R_{D0}$$

p. 683, col. ii.

For "changer value" read "changer valve."

For Q^2 read Q_2 in Equation 6. p. 684, col. i, line 8.

The correct figures are: $Q_4 k_4 = 2$ gives $k_4 = 0.0495$ and $M_4 = k_4 L_4 = 1.235 \mu H$. same col., 6 lines from bottom.

For T^2 read T_2 . col. ii, line 17.

R has been omitted from $R_{D1} = 15,900\Omega$. Part 6, p. 712, col. ii.

The equation for the slope should read:

$$\begin{aligned} \text{Slope} &= \frac{4Q^2}{f_r^2} 2 \Delta f, \text{ etc.} \\ &= \frac{4 Q^2 \Delta f}{f_r^3 \left[1 + \left(\frac{Q^2 \Delta f}{f_r} \right)^2 \right]^{3/2}} \end{aligned}$$

p. 713, col. ii.

Equation 5 f = f_0 should be suffixed to S, reading $S_{f=f_0}$ p. 714, col. i.

Below Table II, the expression for A should read: $A = Q^2 \Delta f / f_0$ and not $Q^2 \Delta f / f_0$.



The abyss of nearly

THE trapeze artiste is an aristocrat in the profession. To avoid "missing it" his life has been an intensive specialization.

When the wheels of industry must run fast less time is available for analysis, for thought, for experimentation. The chances of "missing it" are thus perilously magnified. It is therefore natural that industry today in ever widening fields is relying upon the Simmonds Organization for the development and supply of products bred of the successful resolution of specific problems.

S I M M O N D S

THE SIMMONDS "WAS" NUT
 SIMMONDS-CORSEY CONTROLS
 SIMMONDS CONTENTS GAUGES
 FOR AIRCRAFT.
 SIMMONDS POSITION INDICATORS
 SIMMONDS ELECTRIC TEMPERATURE
 AND PRESSURE GAUGES
 SIMMONDS AIRCRAFT FLOORING



SPIRE "WAS" NUTS
 FRAM OIL & ENGINE CLEANER
 SIMMONDS INDUSTRIAL AND
 MARINE CONTENTS GAUGES
 SIMMONDS JOINTING COMPOUND
 SIMMONDS CRYSTAL UNITS
 SIMMONDS - GOUDIME
 NAVIGATIONAL INSTRUMENTS

SIMMONDS AEROCESSORIES LTD

A COMPANY OF THE SIMMONDS GROUP
 LONDON · MELBOURNE · PARIS · NEW YORK

P.4

ALL ENQUIRIES TO GREAT WEST ROAD, LONDON.

Differential Input Circuits for Biological Amplifiers

By M. G. SAUNDERS, B.Sc.*

THE difficulties of recording simultaneously two or more bioelectric potentials, using conventional grid-earth amplifiers with a common earth lead, were well demonstrated by Adrian and Matthews¹ and ² in 1934. In the case shown in Fig. 1, an impulse at D appears in amplifiers 1 and 2, in opposite phase owing to the impulse feeding back through the common earth, which under these circumstances may be regarded as a common cathode load. Matthews designed a differential input amplifier (2) to overcome this: the circuit is shown in Fig. 2a. Two input valves are used. On considering the circuit it may be seen that it is a modified Wheatstone Bridge (Fig. 2b), V_1 and V_2 being the variable elements in the arms, differences of potential being measured between the anodes—in this case by a following valve. There is no potential difference between the anodes when $V_1 = V_2$, $R_1 = R_2$, and the grids of V_1 and V_2 are at the same potential. When a negative impulse is fed into V_1 , an amplified positive change appears across R_1 , this upsets the balance of the bridge, A (Fig. 2b) becoming positive with respect to B, and the change is recorded by the next stage in the normal manner. When similar in-phase impulses are fed into V_1 and V_2 , the amplified changes across R_1 and R_2 are exactly the same, there is no potential difference between A and B, and so nothing is registered by the succeeding stage. The circuit only amplifies the difference between two impulses fed into V_1 and V_2 ; it is in fact a differential amplifier.

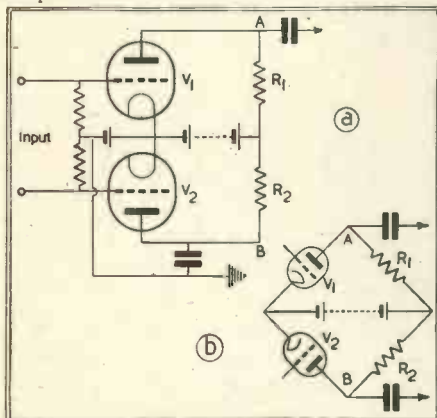

Fig. 2. Matthews' differential input amplifier (a) and its equivalent circuit (b).

Matthews' circuit has found application in bioelectric work since (a) radiated interference (e.g., mains hum) appearing equally in V_1 and V_2 is not

* Department of Electroencephalography, Manchester Royal Infirmary.

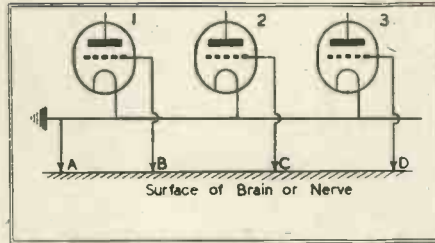

Fig. 1. Method of simultaneous recording from nerve using a reference electrode A and common earth lead.

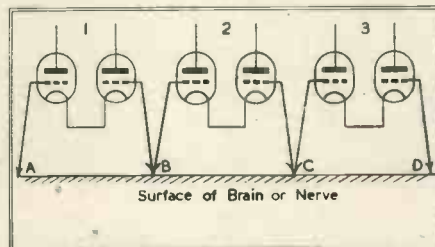

Fig. 3. Arrangement of input leads for balanced amplifiers.

amplified, and (b) the inputs are independent of earth, so that the electrode arrangement in Fig. 1 may be safely used, or still better that shown in Fig. 3, as was done by Adrian and Yamawiga³ and by Grey Walter⁴ for electro-encephalography. The main disadvantage of this circuit lies in the fact that the H.T. battery is "floating" and any slight leaks to earth produce a bad background.⁵

Schmitt⁶ in 1937 described a differential amplifier based on a different principle; the circuit is shown in Fig. 4. V_1 and V_2 are high mu pentodes type 6C6, 57 or 6J7. V_1 is a pentode amplifying in a normal circuit, except that the screen potentiometer network is made up of R_1 , R_2 and the valve V_2 . The anode of the latter is connected to the screen of V_1 , one end of R_2 and through R_3 to a lower tapping on the H.T. supply, the value of which has to be found experimentally.

There are three adjustments to make for correct working conditions. Firstly, the H.T. tap for V_2 is made roughly in the order of the screen voltage of V_1 . Secondly, with the grids of V_1 and V_2 tied to earth the resistance R_2 is adjusted until alteration of R_1 causes no change in the current consumption of V_1 ; under these conditions there is no potential drop across R_1 . Finally, similar in-phase impulses are fed into the grids of V_1 and V_2 and R_3 is adjusted until no output appears across R_1 . The principle upon which the circuit works is as follows: V_1 amplifies normally; V_2 has as its anode load R_1 and R_2 , the latter being variable, so that the amplification of this valve may be adjusted

by R_3 . R_2 acts with V_2 as the other arm of the screen potentiometer network of V_1 . R_2 is adjusted, as has been stated, until there is no potential drop across R_1 ; this makes the output, within reasonable limits, independent of mean input voltages and makes adjustments of the gain of V_1 simpler. When an impulse is fed into V_2 , an amplified change appears across R_1 and R_2 ; this alters the screen potential of V_1 , and so modulates V_1 . An impulse through V_2 undergoes a 180° phase change, thus modulation of V_1 by V_2 is out of phase to direct modulation and when the gain of V_1 equals the gain by modulation through V_2 , in-phase signals cancel out, whilst the difference between out of phase signals is amplified normally. The advantages of this circuit lie in its conventional H.T. supply—with the negative earthed, and a high gain. Schmitt claims that this circuit satisfies the six conditions he considers desirable in differential input amplifiers.⁶

Differential amplifiers using push-pull throughout are commonly used in America. With large in-phase inputs a tendency to modulate out of phase inputs may occur. To overcome this, Offner⁷ described a circuit using degenerative feed-back. The circuit is shown in Fig. 5a, which represents a push-pull circuit having a common unby-passed cathode resistance R_c . Since R_c is the cathode resistance, the potentials across it follow the input potentials into V_1 and V_2 , the amplitude of these being dependent on the values of R_c and R_p . When in-phase signals are fed

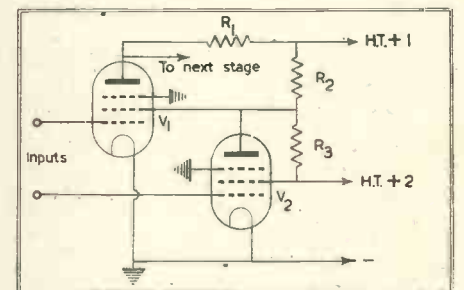
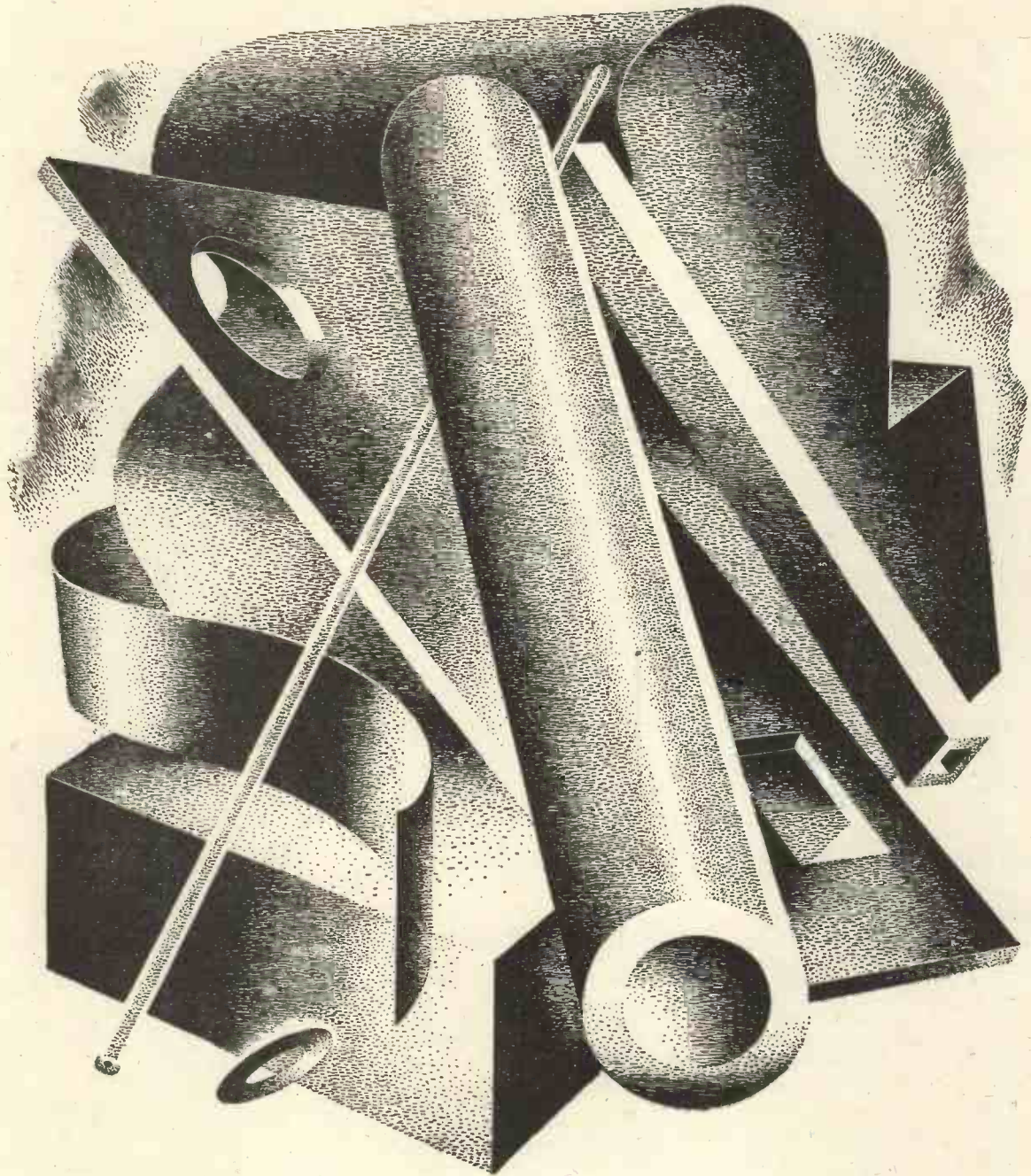

Fig. 4. Schmitt's differential amplifier using high gain pentodes.

into V_1 and V_2 , these appear across R_1 reducing the gain of this stage due to negative feed-back. The gain under these circumstances may be calculated from the formula

$$G = \frac{\mu (R_c + R_p)}{R_c (\mu + 1) + R_p + R_a} \quad (1)$$

where G = the effective gain across the valve, μ = the amplification factor of the valve, R_c = the cathode resistance,



BAKELITE LAMINATED exists in a variety of forms, from wafer-thin sheets to blocks several inches in thickness. Its worth is being proved to-day in countless instances where men's lives depend on the quality of their equipment. Its unique combination of physical properties makes it indispensable where the highest possible efficiency is demanded. Bakelite Limited, Brackley, Northants, will be glad to supply detailed particulars on request.

TREFOIL
BAKELITE  **PLASTICS**
REGD. TRADE MARKS

Pioneers in the Plastics World

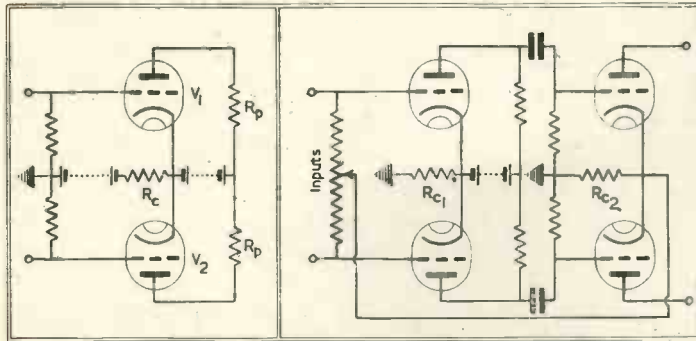

Fig 5. Offner's feed-back amplifier with common cathode resistance, and (b) a similar circuit with feed-back reinforced from a later stage.

R_p = the anode load and R_a = the impedance of the valve. Since R_c is common to V_1 and V_2 , the potentials developed across it will be twice that for a single valve and the formula (1) can be rewritten as

$$G = \frac{\mu (2R_c + R_p)}{2R_c(\mu + 1) + R_p + R_a} \dots (2)$$

The output will be divided between R_c and R_p .

$$E = G \frac{R_p}{R_p + 2R_c} \dots (3)$$

where E = output across R_p , G , R_p and R_c as before. So that the output across R_p shall be very small R_c may be made very large (it being necessary under these conditions to bias the cathode back to a normal working cathode-grid voltage). When out-of-phase impulses are applied to V_1 and V_2 , out-of-phase potentials appear across R_c and so cancel out, no degeneration takes place and the valves amplify normally. Further amplified degeneration can be obtained by feeding back over one or two stages; this is shown in Fig. 5b. Degeneration occurs in each stage in the manner described and this is reinforced by feeding back the potentials developed across the cathode resistance of the second stage to the grids of the valves of the first stage.

In 1938 Matthews⁸ described briefly a differential input circuit using two valves with a common cathode load for phase inversion—a method used by Schmitt⁹ and by Tönnies¹⁰ in similar circuits. Matthews' circuit, originally due, it appears, to Tönnies, has been described in greater detail by the latter.¹⁰ The circuit is shown in Fig. 6a. For analysis of the method of working it is convenient to split the circuit up into two parts (Figs. 6b and 6c). Consider the circuit in Fig. 6b. V_1 is here in a cathode follower circuit (7a and 7b), input into the grid appearing across R_c in the same phase and of amplitude dependent on the valve characteristics

and the value of R_c . The actual gain can be calculated from the formula.

$$G = \frac{R_c (\mu + 1) + R_a}{\mu R_c} \dots (4)$$

with similar notation to that used previously. G is always less than unity, but approaches it the higher the value of R_c . Consider next Fig. 6c, where V_2 has load distributed between anode and cathode; the stage gain may be calculated from formula (1). There are two outputs of opposite phase, one across R_c and the other across R_p , that across R_c following the input. In Fig. 6a the two circuits are joined by the common cathode load R_c ; let the grid of V_2 be earthed and a positive impulse put in V_1 , then a positive impulse appears across R_c of the same phase and amplified about 0.95 times for average values of R_c . This positive impulse appearing across R_c modulates the cathode of V_2 against its grid and causes an amplified positive potential to appear across R_p . At first sight it may seem that the gain of V_2 follows

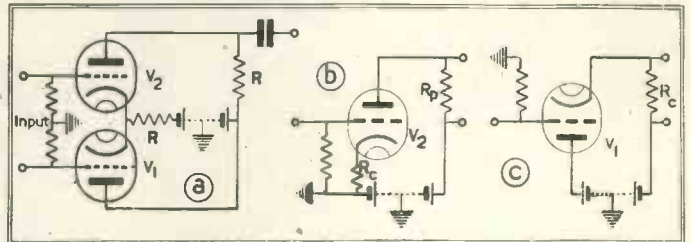

Fig. 6. Tönnies' differential input circuit and its equivalents.

formula (1) and that it is approximately 1.9 (where $R_c = R_p$); this is not so, however, owing to certain characteristics introduced by V_1 and the common cathode load R_c . When a positive potential is fed into the grid of V_2 , a similar potential develops across R_c , making the cathode of V_1 approach its grid. V_1 takes less current and the potential difference across R_c decreases, so opposing the potential introduced by V_2 . The potential across thus remains practically constant and V_2 amplifies as though it had a much reduced cathode load. The value of the potential (E) set up across R_c by an impulse into V_2 may be determined from the formula

$$E = \frac{G R_c}{R_p + R_c} \dots (5)$$

where G = the gain of V_2 considered separately, R_c = the cathode resistance and R_p = the anode resistance. The

value of the opposing potential (E_c) set up across R_c by V_1 may be calculated from the formula

$$E_c = \frac{E}{1/g + R_c} \dots (6)$$

with a similar notation and g = mutual conductance of V_1 . The value of E_c is always less than E and owing to this a certain amount of negative feed-back on V_1 takes place; this feed-back may be expressed as a fraction of R_c .

$$E - E_c \times R_c \dots (7)$$

Since R_p and the effective value of R_c are known, the gain of V_2 may be calculated from formula (1) where R_c here equals its effective resistance. The whole calculation may be done in steps, potential E (formula 1 and 5) developed across R_c from V_2 (considered separately) being found first; then E_c (formula 6), the back potential from V_1 , so giving the effective resistance of R_c ; knowing this the stage gain can be calculated (formula 1), R_c here equalling the effective resistance of the cathode load. When an impulse is fed into the grid of V_1 , a similar chain of events to that just described takes place. There is, however, a loss across R_c (formula 4) and as a consequence the output across R_p due to an impulse put into V_1 is less than when it is put into V_2 ; the circuit in other words does not truly differentiate. The gain of V_2 , when amplifying its own impulses, must be reduced to compensate for the loss from V_1 . Tönnies suggested two methods of reducing the gain of V_2 (a) by a potentiometer in its grid circuit, as shown in

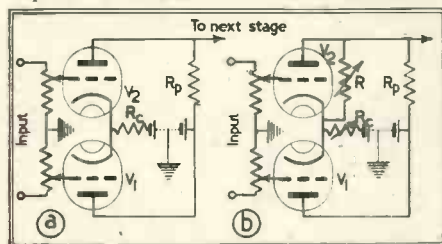

Fig. 7. Modifications of Tönnies' circuit for reducing gain of V_2 .

Fig. 7a, and (b) by putting a resistance across the anode to cathode, shown as R in Fig. 7b.

The values of the resistances in the arms of the potentiometer for method (a) can be calculated knowing the loss from V_1 , which may be determined from formula (4); loss introduced by the potentiometer is made to equal this. An example will illustrate this better.

$$V_1 = V_2 = MH \text{ and from formula (4)} \mu R_c$$

$$\text{gain of } V_1 = G = \frac{R_c (\mu + 1) + R_a}{R_p + R_c} \text{ and loss} = 1 - G.$$

$$\mu = 40, R_c = 70,000 \text{ and } R_a = 11,000 \quad 40 \times 70,000$$

$$\text{so that } G = \frac{70,000 (40 + 1) + 11,000}{70,000 (40 + 1) + 11,000} = 0.975$$

$$\text{and the loss} = 1 - 0.975 = 0.025 \text{ or } 2.5\%.$$

A similar loss may be introduced by resistances of ratio 2.5 to 97.5 in the potentiometer arms, experimental find-

ings gave 2.4 to 97.6. The use of a grid potentiometer is likely to cause bad background in high gain amplifiers and the second method (b) is to be preferred. The value of this resistance is best found experimentally.

In order that the valves V_1 and V_2 in Fig. 6a should work over the same part of their slope, their anode currents should be made the same. This may be done by reducing the H.T. volts of V_1 until the current consumptions are roughly the same; further fine adjustments may be made by altering R_c (Fig. 6.) The circuit is shown in Fig. 8a.

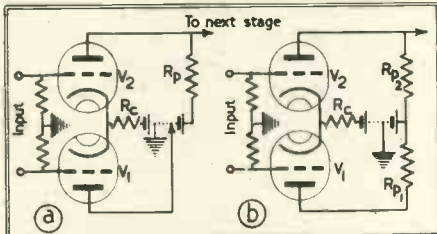

Fig. 8. Methods of matching valve operating points in circuit of Fig. 7. R_c in diagram (a) should be variable.

An alternative method of matching up the valves is to insert an anode load in V_1 (Fig. 8b.) the value of which is equal to R_{p2} of V_2 , and may equal, but not be greater than R_c , the cathode follower action of V_1 being unaltered. For low voltage inputs, the exact matching of the currents of V_1 and V_2 does not appear to be very critical.

In the writer's opinion the circuit of Offner should prove the most satisfactory, as it is the simplest to adjust. In this country it has not, however, been customary to use push-pull throughout—possibly on account of expense. Consequently, one of the other circuits has been preferred, and that of Tönnies is most commonly in use.

The author would like to thank Dr. Schlapp of Manchester University for his kind help in the preparation of this paper. Certain expenses for the experiments involved were defrayed by the Robert Turner Neurological Research Grant.

REFERENCES

- 1 Adrian, E. D. and Matthews, B. H. C., *J. Physiol.* 1934, Vol. 81, p. 440.
- 2 Matthews, B. H. C., *J. Physiol.*, 1934, Vol. 81, p. 28.
- 3 Adrian, E. D. and Yamawiga, K., *Brain*, 1935, Vol. 58, p. 323.
- 4 Grey Walter, W., *Lancet*, 1936, Vol. 2, p. 305.
- 5 Grey Walter, W., Personal communication.
- 6 Schmitt, O., *Rev. Sci. Inst.*, 1937, Vol. 8, p. 126.
- 7 Offner, F., *Rev. Sci. Inst.*, 1937, Vol. 8, p. 20.
- 8 Matthews, B. H. C., *J. Physiol.* 1938, Vol. 93, p. 25.
- 9 Schmitt, O., *J. Sci. Inst.*, 1938, Vol. 15, p. 100.
- 10 Tönnies, J. F. *Rev. Sci. Inst.*, 1938, Vol. 9, p. 95.
- 11 Williams, E., *Wireless World*, 1941, Vol. 7, p. 176.
- 12 Blumlein, A. D. et al, *Jour. I.E.E.*, 1938, Vol. 83, p. 779.

Book Reviews

Automatic Record Changers and Recorders

John F. Rider. J. F. Rider Publication Co., 404 4th. Ave., N.Y., U.S.A.

In these days of restricted publication and thin paper copies it is a pleasant change to handle a volume no less than 2 in. thick with over 700 large quarto pages. It is an encyclopædia of record changers, copiously illustrated with photographs of the mechanisms and full service instructions.

The opening chapters deal with motors and their maintenance, recording apparatus, pickups and needles. A full description of the types of record changer follows with an illustrative example of the R.C.A. RP-152C changer. Although the bulk of the service data deals with American types there are several which are equivalent to the British, e.g., Garrard RC4.

The index and manufacturers' data on record changers has been arranged in the way that has proved successful in other Rider Manuals, and the whole production is a worthy addition to the service engineer's library.

The Radio Handbook

(8th (1942) Edition) by the Editor of *Radio*. 640 pp. 577 figs. and 41 tables. (Editors and Engineers, Ltd., Santa Barbara, California). Price \$1.75 in U.S.A., elsewhere \$2.00.

The *Radio Handbook* is a general compilation of information on the practical aspects of radio.

Investigation to determine the principal sale of previous editions indicates that there were two main classes of buyers: those who were using the handbook as a reference work and hence had greatest need for the comprehensive tables, charts, and formulae; and those schools who were using the *Radio Handbook* as a radio instruction textbook.

As a consequence of this investigation the valve tables have been expanded and brought up to date, and the reference material has been considerably increased. To assist those using the handbook as a text the theory chapters have been rewritten and expanded with an eye to increasing their suitability to this application.

The handbook contains the most comprehensive information available in any one book on all types of transmitting, receiving, and special-purpose valves, 24 pages being devoted to this extensive listing.

This year the price of the *Radio Handbook* has been increased 10 per cent. to offset the increase in the price of paper and printing, and to cover 32 pages more text.

The fact that goods made of raw materials in short supply owing to war conditions are advertised in this magazine should not be taken as an indication that they are necessarily available for export.

Liquid Silver

For Metallising Mica Ceramic Quartz etc.

Low Melting Point Solder and Solder in Paste Form

MELTON METALLURGICAL LABORATORIES LTD.

IPSWICH ROAD TRADING ESTATE SLOUGH, BUCKS.

'Phone: Slough 20992

TAYLOR METER

The Sensitivity of this precision instrument is 1,000 ohms per volt on all voltage ranges.

NEW 38 RANGE UNIVERSAL METER

D.C. VOLTS. 7 ranges from 0-0.25 to 1,000 volts.
A.C. VOLTS. 6 ranges from 0-2.5 to 1,000 volts.
OUTPUT. 5 ranges from 0-2.5 to 500 volts.

D.C. CURRENT. 5 ranges from 0-1 mA to 2.5 Amps.
A.C. CURRENT. 5 ranges from 0-1 mA to 2.5 Amps.

RESISTANCE. 3 ranges from 1 ohm to 1 megohm with internal battery.

RESISTANCE. 1 range from 1,000 ohms to 10 megohms with external 60 volt battery.

DECIBELS. 6 ranges from -22 db to plus 60 db.

METER. 5 Scales covering A.C. and D.C. Measurements and also Ohms and Decibels.

SCALE LENGTH. Outer scale is 3 1/2 inches long.



TAYLOR MODEL 90 £11 - 11 - 0

Supplied complete with lead and test prods, internal battery and instruction book.

British Made by :

TAYLOR

Phone: Slough 21383.

Electrical Instruments Ltd. Sales and Service Dept., 148a High Street, Slough, Bucks.

The Electron

—Recent Progress

By J. M. A. LENIHAN, M.Sc., A.Inst.P.

DURING the past ten or fifteen years, much attention has been devoted to determining the electronic charge and mass, and to more fundamental enquiries concerning the ultimate nature of the electron. The following is a brief summary of the principal trends in experiment and theory at the present time.

Measurement of electronic charge 'e'

(a) *Oil Drop Method.*—Millikan's careful experiment has been repeated, with minor modifications, by a number of workers. The most recent results are:—

Backlin and Flemberg (1936)	e = 4.800
Ishida, Fukushima and Suet-suga (1937)	e = 4.806
Hopper and Laby (1941)	e = 4.802
Millikan (1917) found	e = 4.770

(e is expressed in absolute electrostatic units $\times 10^{-10}$.)

These results are not in very good agreement, and the divergence among them has been the subject of considerable discussion. The trouble is that no completely reliable determination of the viscosity of air (η), which appears in the calculation of e , has yet been made, and the four authors listed above all used different values. The position is clearly put by Robinson (1938): Taking five recent estimates of η and recalculating the results of Millikan, Backlin, and Ishida, he obtains fifteen values for e , ranging from 4.752 to 4.854! It is possible that the uncertainty may be resolved in the light of some experiments performed since 1938, and this point will be elaborated later. Fortunately, e has been found by a variety of other methods, some of which will be briefly described.

(b) *X-ray Method.*—The molecules forming a crystal are arranged in regular fashion, and may be used as a three-dimensional diffraction grating for X-rays. From the diffraction pattern obtained by sending a narrow beam of X-radiation through a crystal, it is possible to calculate the spacing of the molecules, and therefore the number of molecules in each cubic centimetre of the substance. From this may be found the Avogadro constant, N —the number of molecules in one gram-molecular

weight of the substance. The value of e is then simply calculated from the Faraday constant of electrolysis F , which is the quantity of charge carried by one gram-molecular weight of a univalent element when completely ionised in solution, and therefore equals Ne . The X-ray experiments make possible an accurate estimate of N ; F is known from electrolytic measurements. The first worker in this field was Backlin (1928), and recent results are:—

Backlin (1935)...	e = 4.805
Sodermann (1935)	e = 4.806
Bearden (1935)	e = 4.804

Robinson (1938) corrects these figures for a slight error in the wavelength of the X-ray lines used, and finds, as the mean value

$$e = 4.803$$

which is generally accepted as the best value of e from X-ray determinations.

The methods which follow do not give e directly, but lead to some combination of the three fundamental constants— e , m (electronic mass) and h (Planck's constant). Values of m and h are assumed in order to calculate e .

(c) *Limit to Wavelength of X-radiation.*—It is a fundamental postulate of the quantum theory which rules modern physics that radiation of frequency ν has energy in packets, or quanta, of amount $h\nu$, and cannot have less than one quantum. X-rays are produced when fast electrons strike a suitable target, and obviously an electron must have energy at least equal to $h\nu$ before it can cause X-radiation to be emitted. The energy acquired by an electron in falling through an accelerating potential difference X is Xe , and the maximum frequency of radiation resulting from the impact of such an electron is given by

$$h\nu_{\max} = Xe$$

Maximum frequency corresponds to minimum wavelength, and therefore

$$\frac{hc}{\lambda_{\min}} = Xe \quad c = \text{velocity of light}$$

If the minimum wavelength produced by electrons falling through a known potential difference is measured, e

may be calculated. By this method, Du Mond and Bollman (1937) found

$$e = 4.8026$$

(d) *Photoelectric Effect.*—We have just seen that the energy of an electron may be transferred to a wave, in the form of X-radiation. Conversely, X-rays falling on to a surface may give up energy in amounts $h\nu$ to electrons, which will be emitted. The energy of electrons produced in this way has been measured by magnetic deflection experiments; it is, of course, equal to $h\nu$ (with a small correction for the energy lost by the electron in breaking through the surface). A summary of several researches on these lines is given by Robinson (1936) and the results, recalculated by Dunnington (1939) give the value

$$e = 4.795$$

(e) *Ionisation.*—When an electron changes its position inside the atom, its energy changes also. If the energy change is E , it is accompanied by radiation of frequency given by

$$h\nu = E$$

If a substance (usually a vapour) is bombarded with electrons, accelerated by a variable potential difference, X , radiation will first occur when $Xe = h\nu$, ν being the frequency corresponding to the electron-jump with smallest energy charge. X is increased then, until radiation first occurs—usually in the form of light. The frequency of this radiation is measured spectroscopically, and e is found. Further increase in X will lead to radiation of higher frequencies, and e can be calculated in each case from the minimum P.D. required to produce the radiation. Using this method, Whiddington and Woodroffe (1935) obtained the value

$$e = 4.812$$

(f) *Compton Effect.*—It has been stated that light of frequency ν , has its energy in quanta of $h\nu$. When a light-quantum collides with a free electron, that is, one not closely attached to an atom, interchange of energy takes place according to the ordinary laws of mechanics, with a relativity correction. Light scattered by free electrons will therefore merge with reduced energy, and longer wavelength. The wavelength shift was calculated by Compton (1923) and verified experimentally. A determination of e from the Compton effect was made by Ross and Kirkpatrick (1934). Their result, recalculated by Dunnington (1939) is

$$e = 4.7956$$

To come a little nearer home, we may

Tenaplas

EXTRUDED SLEEVINGS and COVERED WIRES are indispensable for Electrical and Chemical insulation wherever precision, ease of handling and absolute dependability are essential requirements.

THE PERFECT INSULATION
TENATUBE
TENAWIRE



TENAPLAS LTD., Head Office, 7 PARK LANE, LONDON, W.1.

THE DIAGRAMS IN THIS JOURNAL ARE LETTERED WITH

“UNO”

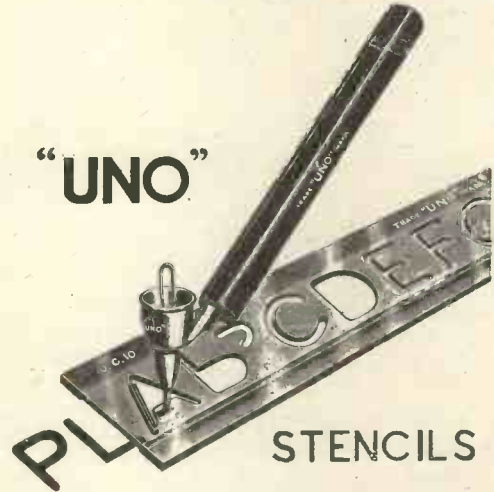

STENCILS
FOR LEGIBILITY & NEATNESS

A. WEST & PARTNERS, LTD.
36, Broadway,
WESTMINSTER

MYCALEX

THE
SUPREME INSULATOR

Can be machined to fine limits. It is constant in temperatures up to 400 deg. Centigrade.

It provides insulation in the face of extremes of climatic and operational conditions.

It is tough and is unaffected by water, gas and oil.

In short, a high priced insulator of great and almost universal efficiency.

Our experience and advice are at your service on application to :—

MYCALEX LTD., CIRENCESTER, GLOS.

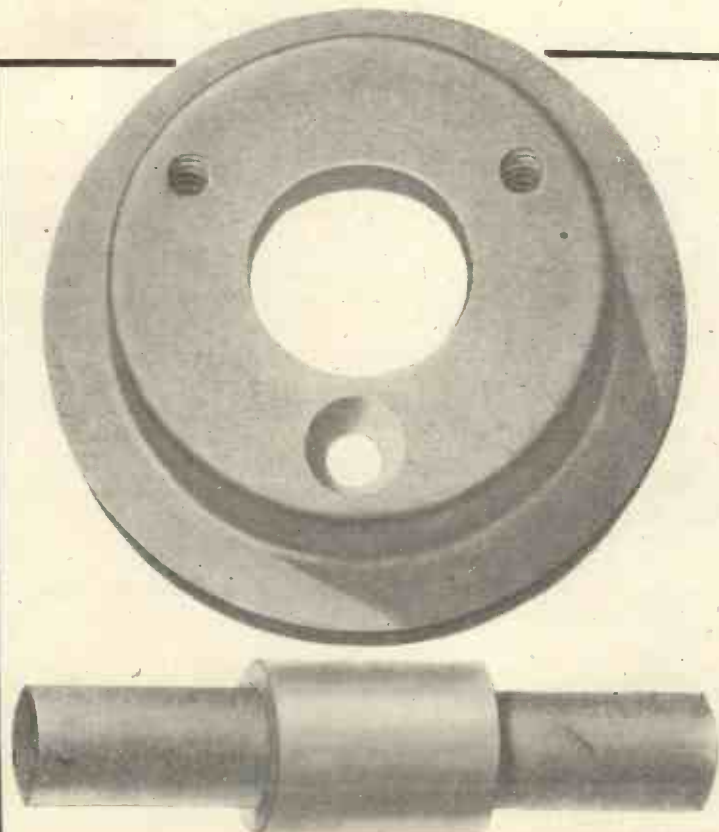

consider a method which, though not of first-grade accuracy, is interesting because it depends on simple properties of the thermionic valve.

(g) *Shot Effect*.—The electron stream in a valve reaches the anode as a hail of independent electrons rather than a continuous stream. This discontinuity produces irregular variations of anode current, and therefore fluctuations of voltage across the anode load. This phenomenon, known as the *shot effect*, was examined theoretically by Campbell (1909) and later by Schottky (1918), with whose name it is generally associated. If the anode load of a saturated diode consists of a resistance R in parallel with a condenser C , it may be shown that the r.m.s. value of the fluctuating P.D. across C is

$$V_{r.m.s.} = \sqrt{\frac{eRI}{2C}}$$

I being the current flowing. Campbell's result has been tested experimentally by Hartmann (1921), and the most recent result is that of Williams and Huxford (1929), who found $e = 4.766$.

For further information concerning the shot effect, the reader is referred to Moullin's book on *Spontaneous Fluctuations of Voltage* (Oxford, 1938).

(h) *Anode Current in a Diode*. We may mention in passing that the anode current in a diode is given by a relation of the form:

$$I = K \sqrt{\frac{e}{m} E^{3/2}}$$

where E is the anode voltage, and K is a constant depending on the size, shape and separation of the electrodes. Many attempts have been made to produce an exact expression for I in valves of different designs, but so far theory has not advanced sufficiently to enable an accurate calculation of e by this method.

Discussion of Results.

Of the methods described, the X-ray and oil-drop experiments possess the least inherent inaccuracy, and should therefore give the most reliable results. Until a few years ago, it appeared that these experiments gave different results. Thus Robinson (1935) quoted as the most probable value of e

4.767 from oil drop experiments, and 4.805 from X-ray experiments.

Shortly after this, several fresh determinations of η were made and in 1938 Robinson considered $e = 4.803$

to be the best value from both methods. This view is confirmed by the very recent oil drop determination performed in Melbourne by Hopper and Laby. Their apparatus differs from the conventional design by having a horizontal electric field, so that the charged drops fall obliquely. This enables the measurements to be made with greater accuracy. Using what they consider to be the most probable value of η the authors find $e = 4.8020$, and recalculate Millikan's result, with the same value of η , to give $e = 4.7992$. Considering all the information at present available, it is reasonable to suggest that the value of e does not differ from

4.8025

by more than one part in five thousand. This must not be taken as a final figure, but it is doubtful whether the accuracy of the oil drop and the X-ray determinations can be increased much further.

The Nature of the Electron—Wave or Particle?

Having reached a fairly satisfactory estimate of the electronic charge, we may conclude by considering another aspect of the electron—its wave nature. The interchange of energy between waves and particles, in, for example, the photoelectric effect and the production of X-rays, has been mentioned. It may be said, in general, that radiation behaves sometimes as waves (interference and diffraction) and sometimes as particles (Compton effect and photoelectric effect). Seeking a way out of these inconsistencies, de Broglie (1924) suggested that a wave motion is associated with every particle, and fills the surrounding space. The hypothesis may be stated in the alternative form that space is filled with waves, and an aggregation of these waves at one place constitutes an electron, or some other unit of matter. The wavelength associated with an electron, according to de Broglie's theory, is of the same order as that of X-radiation—about 10^{-8} cm., and it was suggested by Elsasser (1925) that electrons, if they had wave properties, could be diffracted by a crystal, in the same way as X-rays. Davisson and Germer (1927) showed that this was the case; electrons scattered from the surface of a nickel crystal, used as a reflexion grating, were arranged in a diffraction pattern, thus exhibiting a property characteristic of waves. Similar behaviour has been established in the case of protons, and even whole atoms.

The results of wave mechanics have been used by several workers in determining the electronic charge and mass. Von Friesen (1935) measured the deBroglie wavelength of electrons from their diffraction pattern and calculated that $e = 4.796$. Bearden (1938) experimented on the refraction of electron waves in a diamond crystal, and, using the theoretical results of wave mechanics, found $e/m = 1.7601 \times 10^7$ e.m. units, corresponding to $e = 4.803$.

It does not at the moment appear likely that this new branch of physics will greatly influence the development of electronics, but it is too early to make such a prediction with any confidence.

BIBLIOGRAPHY

- | | |
|--------------------------------|---|
| Backlin | Nature, 123, p. 409, 1929 |
| Backlin | Nature, 135, p. 32, 1935 |
| Backlin and Flemberg | Nature, 137, p. 655, 1936 |
| Bearden | Phys. Rev., 48, p. 385, 1935 |
| Bearden | Phys. Rev., 54, p. 698, 1938 |
| Campbell | Proc. Camb. Phil. Soc., 15, p. 117, 1909 |
| Compton | Phys. Rev., 21, p. 715, 1923 |
| Davisson and Germer | Phys. Rev., 30, p. 707, 1927 |
| De Broglie | Dissertation, Paris, 1924 |
| DuMond and Bollman | Phys. Rev., 51, p. 400, 1937 |
| Dunnington | Rev. Mod. Phys., 11, p. 65, 1939 |
| Elsasser | Naturwiss., 13, p. 711, 1925 |
| Hartmann | Ann. d. Phys., 65, p. 51, 1921 |
| Hopper and Laby | Proc. Roy. Soc. A, 178, p. 243, 1941 |
| Ishida, Fukushima and Suetsuga | Sci. Papers, Inst. Phys. and Chem. Res., Tokyo, 32, p. 57, 1937 |
| Millikan | Phil. Mag., 34, p. 1, 1917 |
| Robinson | Phys. Soc., Progress Report, 1935 |
| Robinson | Phil. Mag., 22, p. 1129, 1936 |
| Robinson | Phys. Soc. Progress Report., 1938 |
| Ross and Kirkpatrick | Phys. Rev., 46, p. 668, 1934 |
| Schottky | Ann. d. Phys., 57, p. 541, 1918 |
| Schottky | Ann. d. Phys., 68, p. 157, 1922 |
| Sodermann | Nature, 135, p. 67, 1935 |
| Whiddington and Woodroffe | Phil. Mag., 20, p. 1, 1909, 1935 |
| Williams and Huxford | Phys. Rev., 33, p. 733, 1929 |

Measurement of Frequencies Below 15 kc/s.

Abstracted from paper read before the I.E.E. on "The Technique of Frequency Measurement and its Application to Telecommunications,"

by J. E. THWAITES and F. J. M. LAVER

FREQUENCIES between about 0.05 c/s. and 10⁷ c/s. can be measured by making the oscillation apparent to the ear or eye of an observer, who uses a stop-watch to time the completion of a convenient number of cycles. For frequencies less than about 1 cycle in 20 seconds it becomes difficult to estimate accurately the completion of the cycle; and for frequencies above 10 c/s. mental counting becomes impracticable and is, in fact, increasingly difficult above 5 c/s. even for trained observers. The method is not accurate over short periods, as a typical example will show. Consider a frequency of 2 c/s. measured by timing 100 cycles of oscillation, over approximately 50 seconds.

Error in estimating completion of 100 cycles exactly is, say, ± 0.2 cycle, i.e., $\pm 0.2\%$.

Error in estimating time interval with stop-watch is, say, ± 0.2 second, i.e., $\pm 0.4\%$.

Overall accuracy = 0.6%.

The stop-watch method may be improved by using a mechanical device to count the number of cycles.

In Fig. 1a the application of an alternating voltage of suitable value to the

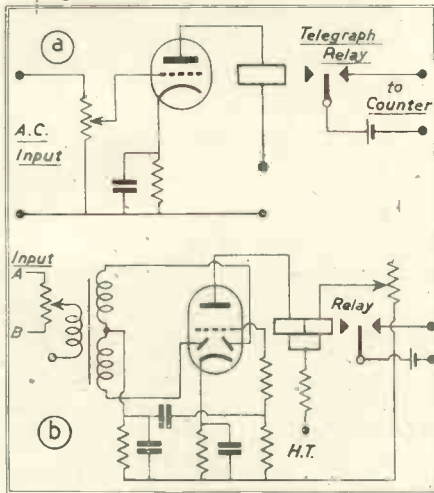

Fig. 1.

input terminals will cause the valve anode current to vary synchronously between zero and some 5 mA; the anode relay operates at 2.0 and releases at 1.5 mA and impulses a counter connected in the local circuit.

Fig. 1b shows a circuit suitable for the comparison of two audio frequencies. The input tones applied at A and B combine in the transformer, and the difference or beat frequency produced by the double diode is amplified by the triode portion of the valve. The relay is set with neutral mechanical bias, and electrical spacing bias is controlled by a rheostat. The use of a

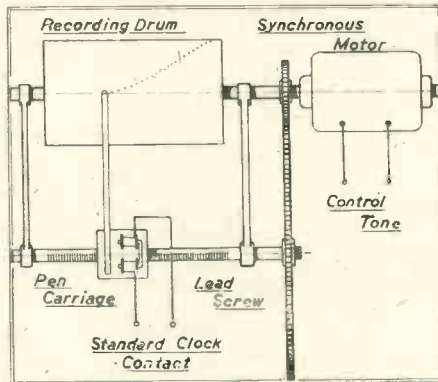

Fig. 2.

common H.T. feeder resistor for the operating and bias windings causes the bias to vary at the beat frequency, in such a manner as to increase the sensitivity of the relay. The circuit will operate satisfactorily for frequencies between 0.001 c/s. and about 150 c/s.

Three types of counter may be used, the double recorder, the uniselector and the Veeder. These counters limit the frequency range to 100 c/s., 50 c/s. and 10 c/s. respectively. The relay may also be used with Case's circuit to actuate a recording microammeter. (See below).

Fig. 2b represents a drum chronograph used for comparing the performances of frequency standards and standard clocks. Thus the chronograph might record hourly clock impulses over a period of several days. The method of interpreting the record may be most clearly demonstrated by an example. Consider a chronograph with a drum 100 cm. long and 50 cm. circumference driven at a nominal 1 r.p.s. by a nominal 1,000 c/s. control. The carriage is traversed at a rate of 0.5 mm/s. the pen being impulsed at 1 second intervals by a standard clock. Suppose the trace is a straight line inclined to the axis of the cylinder at a slope of 1 cm. on the 100 cm. length.

Advance on 100 cm. = 1 cm.

Advance on 0.5 mm. =

$$\frac{1 \times 0.5}{1,000} = 0.0005 \text{ cm.}$$

$$\text{Rate of revolution} = \frac{50.0005}{50} \text{ r.p.s.}$$

$$\text{Control frequency} = 1.00001 \times 1,000 = 1,000.01 \text{ c/s.}$$

With such a chronograph a slope of 1 mm. on the 100 cm. length, which corresponds to a deviation of 1/10⁵ from exact frequency, can be discerned.

Case's Circuit

The circuit shown in Fig. 3a was originally used by Maxwell for approxi-

mate measurements of capacitance. So long as the time constants are low enough to ensure complete charge and discharge within the limits of measurement, then the quantity of electricity which traverses the milliammeter in a given time depends on the number of discharges of the condenser in that time, i.e., upon the frequency of the current which impulses the relay. In practice a 100 c/s. calibration frequency is applied and the condenser C is adjusted so that the meter reads 100, and then it is direct reading in frequency to an accuracy of about 1 per cent., over a range 5-200 c/s.

To extend the arrangement to frequencies as low as 0.2 c/s. a modified

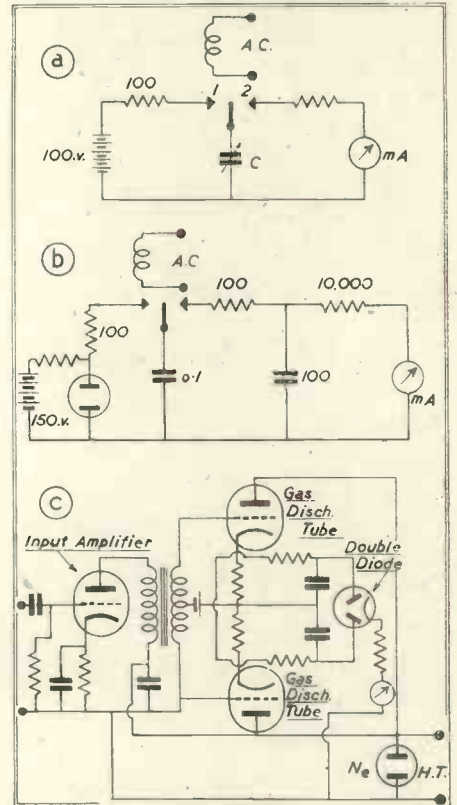

Fig. 3.

circuit, shown in Fig. 3b is used, in which the meter circuit is given a high time constant in order to prevent the individual pulses of low-frequency oscillations from affecting the meter reading. The use of a neon lamp to stabilise the voltage improves the accuracy of measurement. A synchronous motor driving a series of cam switches may be used for L.F. calibration.

Electronic Frequency Indicators

There are many circuits which use thermionic valves or gas-discharge tubes to replace the polarised relay of (Concluded on p. 770)

Measurement of the Slope and Duration of Television Synchronising Impulses

By R. A. MONFORT and F. J. SOMERS

A Summary of a paper presented at the I.R.E. Convention, 1941, and subsequently printed in R.C.A. Review, Vol. VI. No. 3.

THE tolerance prescribed for the steepness of wavefronts as well as the duration times of the various impulses that go to make up the composite synchronising signal require measuring equipment capable of determining fractional microsecond time intervals. A further requirement equally as important as high precision, is that the measuring equipment should be simple, and easy to use under actual operating conditions.

An idea of the precision required may be gained from the fact that under the present standards of 525 lines, 60 fields, interlaced, the maximum time allowed for the transition from the 10 per cent. to the 90 per cent. amplitude point of the horizontal synchronising wave is only 0.25 microsecond. The tolerance allowed for variations in the width or duration of horizontal synchronising impulse is also a small value, being limited to 0.64 microsecond. Similar close tolerances have been specified for other parts of the wave.

It can be shown that faithful reproduction of the wave of Fig. 1a which

has equal build-up and decay times of 0.5 per cent. of a scanning cycle requires that the oscilloscope signal amplifier be responsive up to the 20th harmonic of the scanning-line frequency. Translated into terms of the present television standards, this means that the oscilloscope signal amplifier should have linear phase and flat amplitude response from below 60 c.p.s. up to at least 3.15 megacycles/sec. A tube having a screen diameter of at least five inches should be employed, but a nine-inch tube is preferable for accurate work.

On a five-inch oscilloscope screen, the necessity of showing at least two cycles means that D (Fig. 1b) will be less than 100 mm. At the same time the probable error in scale reading, taking account of the width of the oscilloscope trace may easily amount to ± 1 mm. It can readily be seen that serious errors will occur if attempts are made to measure the slope of the leading edge of the horizontal synchronising wave with this setup, since the value C' being less than 0.4 mm., cannot be accurately read with the scale. As a matter of fact, errors due to unsteadiness of the image and non-linearity of the sawtooth wave can easily add up to more than 1 per cent. of the scanning cycle, making the error greater than the value to be measured.

A method of measurement which is at once simple and accurate within reasonable limits, uses an oscilloscope with sine-wave horizontal deflection. The frequency of the sine wave used is either the same or a harmonic frequency of the impulse being measured. The pattern on the oscilloscope screen is stationary since the sine wave is derived either from the synchronising generator or directly from the synchronising impulse itself. A convenient phase-shifting device is provided so that the part of the wave of greatest interest can be moved to the centre of the screen where it appears expanded horizontally. This feature of sinusoidal sweep tends to increase the accuracy obtained in measurement of impulse widths and slopes, since the dimensions to be measured are larger for a given width of horizontal time axis than if sawtooth

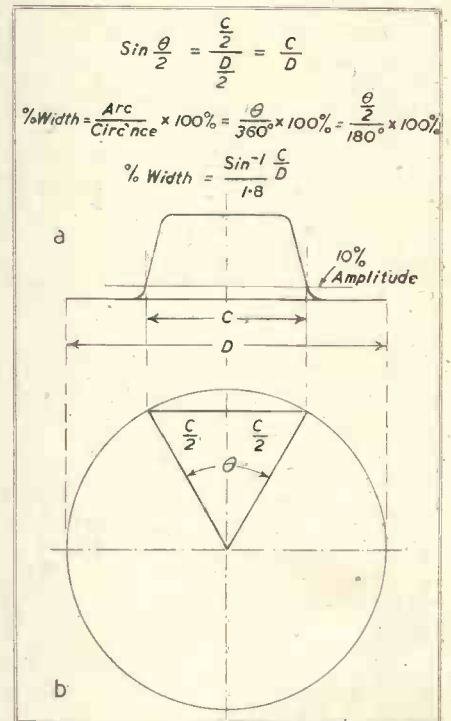

Fig. 2.

waves are used. Also, since only one cycle appears on the screen, the effective horizontal time base can be wider than with sawtooth sweep, where, as already pointed out, more than one cycle must be included in the horizontal direction.

The procedure in making measurements with sine-wave horizontal deflection is illustrated by Fig. 2a, which shows a train of horizontal driving impulses as they appear on the oscilloscope using 15,750 cycle sine-wave sweep. This type of impulse is utilised for energising the horizontal sawtooth-wave generators of television cameras and video monitors in the television plant, and normally has a time duration of 6 per cent. of a scanning cycle. The impulse is moved to the centre of the screen by means of the phase-shifting device already mentioned and its width or duration can then be found by means of the following equations (Fig. 2b).

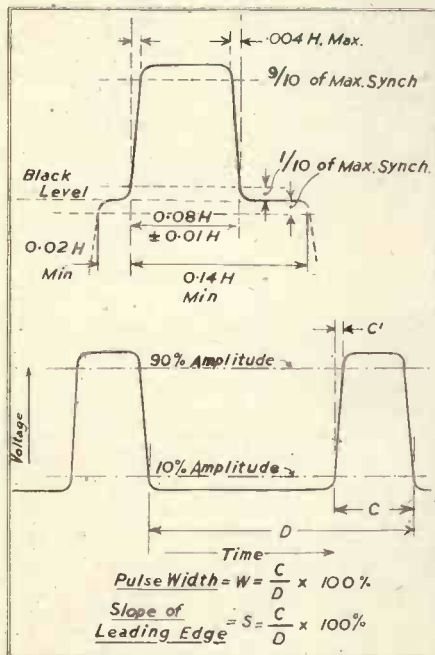
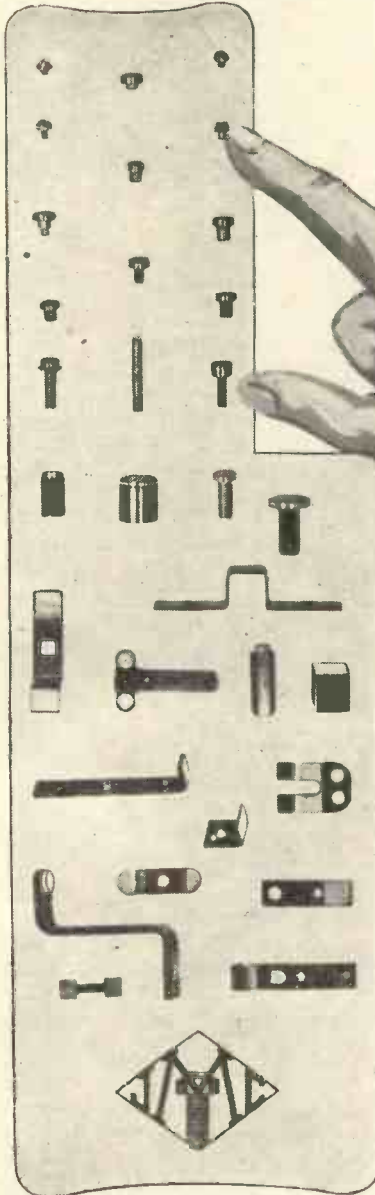

Fig. 1.

$$\text{Pulse Width} = W = \frac{C}{D} \times 100\%$$

$$\text{Slope of Leading Edge} = S = \frac{C}{D} \times 100\%$$

"Just the Contact for the Job"



Write for Booklet 112, giving details of J. M. C. contacts and contact materials.



The selection of suitable contact materials and types of contact, presents problems to designers in all grades of electrical engineering. It is accordingly our keen desire to be of service by presenting the fullest available information and guidance to those who seek assistance in determining the most suitable contact for a specific job. May we assist you?

JOHNSON, MATTHEY & CO. LIMITED

73/83, HATTON GARDEN, LONDON, E.C.1

Telephone: HOLBORN 6989



Another 65-watt SOLON

This 65-watt industrial type SOLON is fitted with an oval tapered bit—a popular shape for all general work. Pencil bit types and heavier models are also available.

Details of this and other models sent on request.



Due to the heavy demands, it is necessary to order well in advance to avoid disappointment in delivery.

W. T. HENLEY'S TELEGRAPH WORKS CO., LTD.,
Engineering Department., Milton Court,
WESTCOTT, DORKING, SURREY.

CONSTANT VOLTAGE

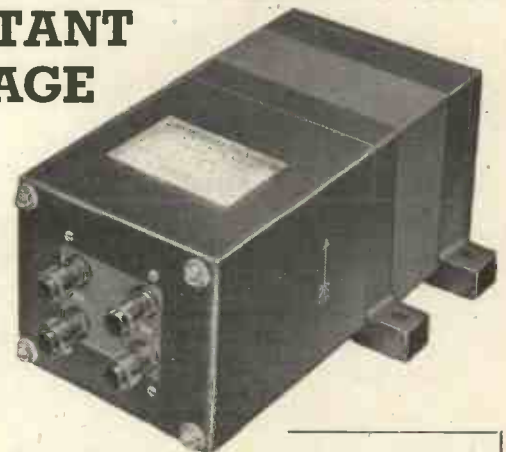

A NEW **ADVANCE** IN TRANSFORMER DESIGN

Line voltage variations of $\pm 15\%$ reduced to $\pm 1\%$

Stabilize your Electrical Instruments by using an "ADVANCE" Constant Voltage Transformer

TYPICAL SPECIFICATION:

Input Voltage:	190-260 v. 50 c.
Output Voltage:	230 v. $\pm 1\%$.
Max. load:	150 watts.
	Input power factor over	90%.

Write for details.

Price on application.

ADVANCE COMPONENTS LTD.,

Back Rd., Shernhall St., Walthamstow, London, E 17

Telephone: Larkwood 4366-7

$$\sin \frac{\theta}{2} = \frac{C/2}{D/2} = \frac{C}{D}$$

Per cent. width = $\frac{\text{length of arc}}{\text{circumference}} \times 100 = \frac{\theta}{360^\circ} \times 100$

$$\text{Per cent. width} = \frac{\theta}{180^\circ} \times 100$$

$$\text{Per cent. width} = \frac{\sin^{-1}(C/D)}{1.8}$$

where the angle is expressed in degrees.

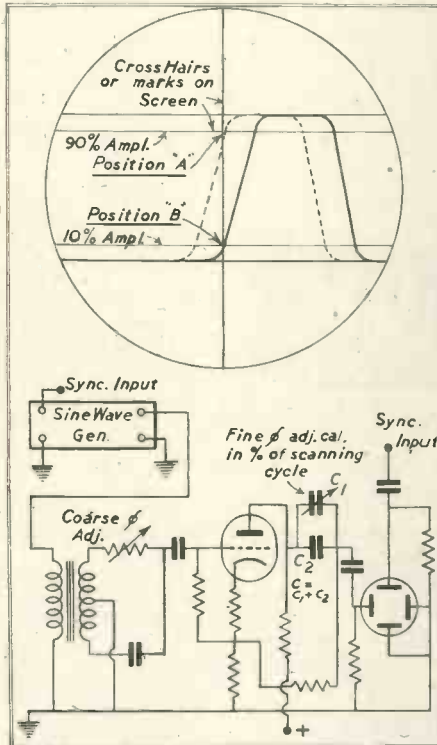

Fig. 3.

By measuring C and D in mm., with a transparent scale attached to the oscilloscope screen and applying the above equations, the duration of the impulse can readily be found.

One of the most serious sources of error in making measurements of this kind is in taking the millimetre scale readings. It can readily be shown, however, that errors in scale readings are minimised when sine-wave sweep is used, as compared to linear or sawtooth sweep. To give a concrete example, suppose we are measuring the width of the horizontal synchronising impulse which has a specified duration of 8 per cent. ± 1 per cent. of a scanning cycle and that the D dimension is 100 mm. For the sawtooth sweep, the value of C will be 8 mm. However, the error in reading the scale can easily be as much as ± 1 mm. Consequently, reading D ± 1 mm. too small and C ± 1 mm. too large, gives an answer of 9.1 per cent. which represents an error greater than the allowable tolerance for the width of the wave. Under the same conditions,

using sine-wave sweep with D also 100 mm., reading D ± 1 mm. too small and C ± 1 mm. too large, gives an answer of 8.42 per cent. which is within the prescribed tolerance. Another source of error is the presence of harmonics in the sine wave. While a rigorous analysis has not been made for all possible harmonic content, depending on its phase, can produce a maximum error of 0.22 per cent. of a scanning cycle in the measurement of the width of the horizontal synchronising signal. This amount of error will probably not be exceeded if the arithmetic sum of all harmonics present is held down to 1 per cent.

If reasonable care is taken to minimise the errors referred to, the sine-wave method gives impulse widths to an absolute accuracy of $\pm \frac{1}{2}$ per cent. of a scanning cycle. While higher accuracy is desirable the results are at least practical, since they are within the tolerance prescribed for these waves.

Increased accuracy can also be obtained with the modified measurement procedure shown in Fig. 3, which eliminates the need for charts or scales and gives impulse-width and slope values read directly from a calibrated dial. In this arrangement, the wave is brought into approximate position with respect to the cross hairs by means of the coarse phase adjustment. A fine phase adjustment provided with a dial calibrated in 1 per cent. of a scanning cycle is then used to shift the wave back and forth with respect to a fixed hair line in the centre of the oscilloscope screen. The difference in dial readings for the 90 per cent. amplitude point of the wave at position "A" and the 10 per cent. amplitude point at position "B" gives the slope of the leading edge of the impulse directly in per cent. of a scanning cycle. The slope of the trailing edge can be measured in the same way. Similarly, the duration of the impulse can be found by taking two readings at the intersection of the 10 per cent. amplitude line and the vertical index mark. The phase-shifting arrangement shown is a modification of that described by Hartshorn* and gives a constant output voltage within the limits of voltage regulation of the amplifier feeding it. Over the small range required of the calibrated phase shifter, R and C can be chosen so that there is negligible change of amplitude with change of phase. Tests show that the results obtained with this arrangement are independent of moderate amounts of compression in the horizontal deflection amplifier of the oscilloscope, since even under these conditions the sweep will be linear in the central portion of the screen where observations are made. This latter feature plus the elimination of scale-reading errors makes for increased accuracy.

* L. Hartshorn, Proc. Phys. Soc. (London) Vol. 49, Part 2, March, 1937.

Frequency Measurement below 15 kc/s.—
(Concluded from p. 767)

Case's circuit. Instruments of this type may be used for frequencies as high as 100 kc/s. to an accuracy of ± 3 per cent. The arrangement of a commercial model is shown in Fig. 3c. The instrument consists essentially of an electronic counter and an indicator. Thus when an alternating voltage is applied to the grids of the gas-discharge tubes each tube becomes alternately conducting and non-conducting. At each transition of the current from one tube to the other a current pulse traverses the indicator circuit, and the meter reading depends on the number of pulses per second, i.e., upon the frequency.

Bridge Circuits

The alternating voltage of unknown frequency is applied between two points of an electrical network, and by a suitable adjustment of the values of self or mutual inductance, capacitance and resistance, the unbalance voltage between two other points is reduced to zero as indicated by a detector. One of the adjustments depends on the frequency of the alternating voltage so that the circuit may be used as a frequency meter.

Of the many circuits which may be used, the Wien capacitance bridge (Fig. 4) is perhaps the most convenient.

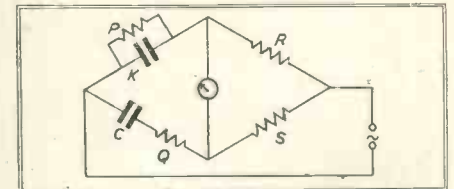

Fig. 4.

The balance conditions are

$$K = \frac{S}{C} = \frac{R}{R + \omega^2 C^2 Q^2}$$

$$P = \frac{S}{\omega^2 C^2 Q}$$

whence $\omega^2 K C P Q = 1$; $f = \frac{1}{2\pi\sqrt{K C P Q}}$

Robinson² made this a direct-reading frequency meter by arranging $K = C$, $S = 2R$, and $Q = P$. Also R, S, K and C are kept fixed, and to avoid the need for a double adjustment P and Q are altered together in equal steps. For balance $\omega = 1/(PC)$, so that for direct reading the steps of P and Q go in conductance values, e.g., 100, 50, 33.5, 25, 20, 11.1, 10 ohms. The measurement accuracy is about ± 0.5 per cent. and the bridge may be used for frequencies up to about 20,000 c/s. Headphones or a valve voltmeter are used as the null detector, and since the bridge is not balanced to harmonics, the use of filter circuits is recommended.

¹ N.P. Case : "A Precise Method of Measuring Frequencies from 5 to 200 c/s." Proc. I.R.E. 1930, 18, p. 1586.

² C. Robinson, "A Direct-reading Frequency Meter for Telephonic Currents," Post Office Electrical Engineers' Journal, 1924, 16, p. 171.

ABSTRACTS OF ELECTRONIC LITERATURE

ELECTRO-MEDICAL

Capacity Diaphragm Manometer (J. C. Lilly)

A new type of diaphragm manometer for direct pressure measurements in the arterial blood stream and in other fluid systems uses a r.f. crystal-controlled oscillator and a pressure-sensitive condenser in the pick-up unit. The manometer has a needle for arterial puncture at one end which communicates by way of a short length of stainless steel tubing with a diaphragm (see Fig.) about $\frac{1}{4}$ in. effective diameter by .005 in. thick.

This is held .0005 in. from an electrode $\frac{3}{16}$ in. diameter, the whole being assembled in a small box 4 by $3\frac{1}{2}$ by 2 in. which also holds the r.f. circuit. The circuit is of the conventional type with crystal control (14 Mc/s.) and is battery operated.

The sensitivity of the manometer system is 1 mm. Hg. per inch deflection on the C.R. tube and the cut-off frequency approximate 580 c.p.s. with a No. 22 needle. It is pointed out that the sensitivity can be increased by using a dielectric liquid in the diaphragm-electrode space such as glycerin.

—*Rev. Sci. Inst.*, Vol. 13, No. 1 (1942), page 34.

INDUSTRY

Two Bridge-Controlled Thyatron Thermostats (D. Bancroft)

Two circuits for the regulation of temperature by means of a bridge-controlled thyatron are described. The first utilizes a resistance thermometer, the second controls through changes in the resistance of the furnace winding. Improved stability is achieved by adequate filtering of the voltage applied to the control grid of the thyatron. The circuits are so designed that extreme overload in control voltage never causes erratic behaviour, thus when the thermostatic bridge is set for a new temperature, unstable operation does not occur, the control is established smoothly and promptly.

—*Rev. Sci. Inst.*, Vol. 13, No. 1 (1942), page 24.

Insulation Resistance Meter (T. Rehfish)

For testing small mica or ceramic condensers, this meter has been designed to cover a range of 10^7 - 10^{12} with alternative test voltages of 500, 750 and 1,000. The supply is connected to the unknown resistance R_x in series with a known resistance R_s (R_x), the voltage across the latter being measured by a valve circuit. From V_0 , the applied voltage and the value of R_s , R_x may be found. Circuit details are given.

—*Wireless Eng.*, Vol. 19, No. 221 (1942), p. 49.

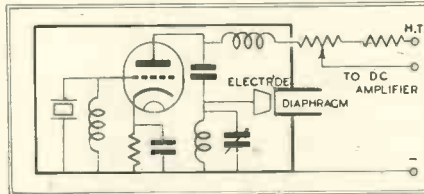
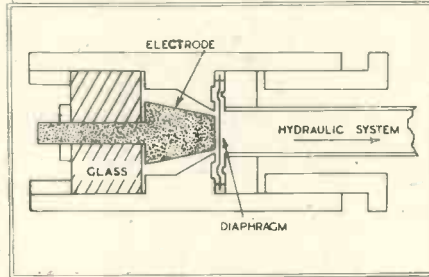

Egg-Laying as a Relaxation Oscillation

Van der Pol has already pointed out that the formation and deposition of an egg can be described as a relaxation process (*Phil. Mag.*, 2, 978), the egg material being piled up gradually and released suddenly.

The sustained production of eggs can then be regarded as a series of relaxation oscillations.

In an undisturbed relaxation system discharges take place when the accumulating material (energy) reaches a certain level, but the length of period may change if the stream of material (energy) varies.

If the bird were an undisturbed relaxation system, eggs of fairly constant size would be expected at varying intervals according to the amount of food available.

This is not the case in ducks, where eggs of varying size are deposited regularly in the morning on consecutive days, sometimes for months with pauses of one, seldom two or more days between each clutch.

Now constant period length and variable amplitude, although foreign to relaxation oscillations, are characteristic of the well-known type of sinusoidal oscillation. A duck's egg laying activity combines features of both types of oscillations due to the synchronizing of an external sinusoidal 24 hour rhythm on the relaxation system. The eggs of a clutch, decrease in weight so that the first egg is usually the heaviest and the last egg the lightest. The differences between the biggest and smallest egg laid by one duck are not great (c. 20%) and extremely small eggs (35 gm.) and big eggs (double yolked, eggs—more than 110 gm.) are exceptional.

Kalmus.—*Nature*, Vol. 148, p. 626, 1941.

An Electron Microscope for 220 KV. (H. O. Muller and E. Ruska)—Siemens and Halske Electronoptics Laboratory

For high resolution to be obtained with the electron microscope very fast electrons, obtained by acceleration through high voltages, must be used. The advantages arise from the greater depth of penetration of the electrons, except in the case of extremely thin layers. This is true for light and dark field illumination.

The electron microscope was therefore designed for 220 KV—using two stages. The circuit for obtaining a smoothed H.T. supply variable up to 220 KV is described. The electron microscope, employing a final beam current of 20-50 microamperes is a modification of the usual Siemen's pattern, which is described in detail by von Borries and Ruska (Siemen's Z. 20, 217, 1940). Magnetic focusing lens systems are employed both for the object lens and the final magnifying "projection" lens; the focal lengths were 3.2 and 1.8 mm. respectively, as compared with 6.5 and 3.5 mm. obtained hitherto with electrostatic lenses with only 40-50 KV final voltage. This in magnification alone gives a four-fold improvement. The desirability of the combination of a magnetic focusing system with a high voltage in the penetration electron microscope was pointed out by Ruska in 1936.

Figures show photographs, at a magnification of 15-16,000 taken with the present apparatus in comparison with others at lower voltages. These are—Serpentine asbestos, Granule of Tubercle bacillus. Blood corpuscle of patient with "Thrombopenischer Purpura," Bacterium and finally the improved gradation at high voltages.

—*Kolloid Zeitschrift Bd.* 95 (1941), p. 21.

MEASUREMENT

Geiger-Muller Photoelectron Counter (Duffendack and Morris)

The construction of a photoelectron counter with a nickel cathode and a quartz envelope is described and an account is given of comparative tests on the measurement of the relative intensities of spectral lines with the counter and by means of photographic spectrophotometry. The counter has a linear response to variations of intensity of light over a wide range. For measuring the relative intensities of spectral lines the counter tube is mounted on a spectrograph behind a slit which moves on the focal plane of the instrument so that spectral lines are measured singly. The application of the counter in spectrochemical analysis is demonstrated and comparative analyses of the same materials by use of the counter and by method of spectrochemical analysis are given.

—*Jour. Opt. Soc. Am.*, January, 1942, p. 8.

PATENTS RECORD

The information and illustrations on this page are given with the permission of the Controller of H.M. Stationery Office. Complete copies of the Specifications can be obtained from the Patent Office, 25, Southampton Buildings, London, W.C.2, price 1s. each.

INDUSTRY

Photographic Recording and Reproduction of Impulses

To provide an improved apparatus and method of operation whereby different frequency components of impulses, such as those of audio-frequency, are recorded in different forms, and to obviate the distortion usually involved by recording all the impulse frequencies in the same form.

The diagram shows light from a source 15 projected through a lens 16, a multi-apertured mask 17, a single-apertured mask 18, a cylindrical lens 19 and a spherical lens 20 to a galvanometer mirror 21. From this mirror, light is reflected through lens 22, the light slit of mask 23 and lens 24 to a photographic record 25. The function of the multi-apertured mask is to produce at the mirror a pair of oppositely shaded penumbra shadows, the images of which are vibrated transversely to the light slit 26 in accordance with the high frequency components. Thus the aperture 27 produces at the slit an image 27' which is brightest at its lower edge and becomes gradually darker as its upper edge is approached. Similarly, the aperture 28 produces at the slit an image 28' which is brightest at its upper edge and becomes gradually darker as its lower edge is approached

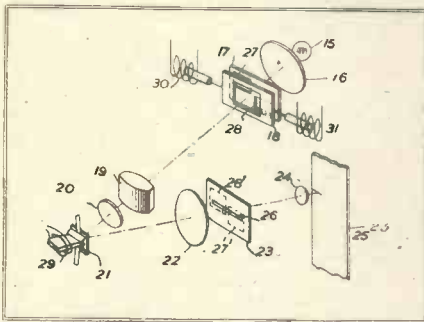

If the operating coil 29 of the recording galvanometer is energised in accordance with the high frequency impulses, there is produced on the record strip a high frequency push-pull record track. The low frequency push-pull record track is produced by the single-apertured mask 18 which is moved longitudinally to the slit by means of operating coils 30 and 31. These coils are supplied with the low frequency components of the recorded impulses. The distortion which would otherwise be produced by fogging of the valleys and under-exposing the peaks of the high frequency waves is not present in such low frequency waves. The superiority of the variable area record track with respect to photographic development

processes is retained. The masks 17 and 18 are mounted closely together and slightly spaced from one another horizontally for the purpose of separating the images 27' and 28' and producing image separation line.

—Radio Corporation of America.
Patent No. 538,771.

Improvements in Photoelectric Cells.

The object of the invention is to provide an improvement in selenium cells. The second layer instead of consisting of a single metal is a composite layer made up of a number of component metals, which are applied subsequently to the application of the first layer.

The selection of the composition of the second layer enables additional colour filters to be dispensed with or very much simplified. This layer serves not only as the conductor for picking up the current generated when the light falls on the cell, but also as a colour filter of closely adjusted transparency spectral distribution.

—G. A. Vessi. Patent No. 542,599.

CIRCUITS

Circuit arrangement employing critical transit time electron discharge valves.

Circuit arrangements in a high frequency system where means are provided for predetermining the terminal impedance of the circuit. This comprises a diode coupled to the circuit and means for varying the electron transit time of the diode to cause it to be critically related to the high frequency period so as to function as a negative resistance.

—Standard Telephones and Cables.
Assignees of F. B. Llewellyn.
Patent No. 541,604.

Frequency Demodulation.

A demodulator for frequency modulated signals in which the frequency variations are converted into amplitude variations by means of a valve circuit having two states of stability. This is triggered from one state to the other by the successive half cycles of the frequency modulated wave applied to it, and produces unidirectional pulses varying in frequency in accordance with the frequency variations. These pulses have constant amplitude irrespective of any amplitude changes in the incoming signal above a predetermined threshold value, the pulses being integrated to produce an average current varying in accordance with the frequency variations.

—Marconi's Wireless Telegraph Co.,
Ltd. Assignees of G. R. Clark.
Patent No. 539,254.

CORRESPONDENCE

Electronic Switching

DEAR SIR,—In the circuit diagram accompanying my description of Clothier's electronic switch applied to medical research there is one variation from Clothier's original circuit.

The bias of both pentodes is shown variable by the resistances R.27 and R.29. This is unnecessary as the traces settle down to positions equidistant from the mid-positions on the tube and any attempt to position the traces asymmetrically with respect to the mid-position introduces a D.C. component which is lost in C.9.

If the bias of V.6 is returned to a fixed centre tap on R.27 the difference in bias causes the traces to set themselves on either side of the mid-line.

The loss of extra L.F. and the D.C. component in C.9 is a drawback, as if one trace swings slowly the other trace tends to swing in the opposite direction by an equal amount.

The frequencies where this begins to show depend on the value of C.9 and the deflector plate—earth resistance.

In the equipment which I have in hand now I am omitting C.9 and raising the tube anodes to approximately the anode potential of V.5 and V.6. R.27 and R.29 should then give an absolute setting of position and the coupling on the slow swings be abolished.

Recent trials indicate that four traces on the same tube should be perfectly satisfactory

Manchester. G. D. DAWSON.

Photography of Tube Traces

DEAR SIR,—In the formula for the fractional error given on page 721 of the April issue (col. 1) a minus sign appears instead of a multiplication sign between

$$L + D \quad \text{and} \quad \frac{[R - \sqrt{(R^2 - h^2)}]}{[D + R - \sqrt{(R^2 - h^2)}]}$$

The curves have, of course, been derived from the correct formula.

Highbury, N. H. MOSS.

Simple R.C. Oscillator

DEAR SIR,—Mr. Bacon, in his note on a "Simple R.C. Oscillator" in the April issue omits to record that the circuit was described by Ginzton and Hollingsworth in *Proc. I.R.E.* for February, 1941. It was, in fact, first described in a U.S. patent as long ago as 1921.

The detailed calculations for the frequency and amplification necessary to reproduce oscillations will be found in the above paper and these give the correct value for the frequency as:

$$f = \sqrt{\frac{7}{10}} \cdot \frac{1}{2\pi RC}$$

and the minimum amplification as 271/49 or 5.53.

Both these figures depend on R being much greater than the anode impedance of the valve.

Newcastle. J. M. A. LENIHAN.

COMMUNICATIONS DEPEND....

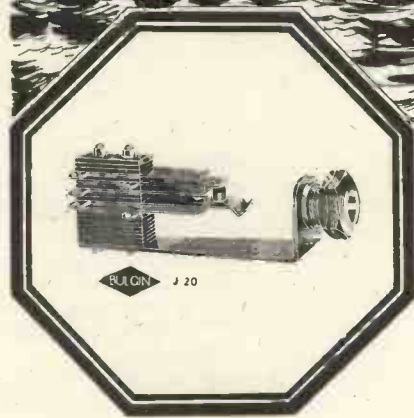

ON SMALL PARTS....

In countless instances quite intricate pieces of apparatus are wholly dependent on the proved reputation and reliability of their component parts.

All products from the House of Bulgin are pre-eminent for superior design and workmanship, and every article bearing our Trade Mark has to pass exacting and exhaustive tests during the course of its production.

We ask the kind indulgence of the Trade on delivery until peaceful conditions return.

The Choice of Critics

BULGIN

FOR

JACKS

A Large and comprehensive range of Jacks, standard to B.S.S. 666, fixing with single $\frac{3}{8}$ " hole to panels 0.036—0.250" thick; single-, double-, and triple-pole, with and without switching. Only 2 $\frac{1}{8}$ " rear depth. 'Panel-area' taken up = $\frac{11}{16}$ " \times $\frac{3}{4}$ " average. Best bakelite insulation, nickel-silver leaves, silver switching-contacts.

" The Choice of Critics "

BULGIN

REGISTERED • TRADE • MARK

A. F. BULGIN & CO. LTD., BY-PASS RD., BARKING, ESSEX

Tel. Rippleway 3474 (4 lines)



A spontaneous expression of opinion may constitute an apt specification, but hardly of the kind to which we are accustomed.

In any case, in these days it is not easy to carry out an exacting specification but "where there's a will, there's a way" and it is done, and done very carefully, but unfortunately not as quickly as we would like.

You know the difficulties don't you, but although deliveries may be delayed our services are at your disposal freely and immediately.

Manufacturers of Variable Voltage Transformers, Constant Voltage (flux regulated) Transformers, Transformers with high leakage reaction, Scott Groups, Swinging Chokes, High Current (plating) Transformers, Battery Charges d.c. supply units, Flash Testers, Amplifiers, etc.

W ANDREW & COMPANY LTD

BRYCE

BOREHAM WOOD

HERTS
TELEPHONE • ELSTREE 1875

NOTES FROM THE INDUSTRY

Retirement of Mr. E. Gimingham

The resignation of Mr. E. Gimingham from the Board of the Edison Swan Co., severs another link with the early days of the lampmaking industry and Sir Joseph Swan, the father of the electric lamp in this country.

Mr. Gimingham was associated with Sir Joseph in 1885 and supervised the manufacture of lamps first at Newcastle and then at Ponders End. He also made the first vacuum flasks for Sir James Dewar and the first vacuum diodes for Sir Ambrose Fleming, who was consultant to the company at the time.

The most important of Mr. Gimingham's own contributions to the lamp industry was the development of the "Pointolite" lamp in collaboration with Mr. S. R. Mullard and the modern version of this lamp differs in little respect from the original type made to his design. He also designed a dual-filament lamp incorporating a reserve filament which was brought into use by removing a mica separator from the contacts in the cap.

Mr. Gimingham has long held the esteem of his colleagues and workers on the company's staff for his practical abilities and unflinching friendliness and we join with them in wishing him good health in his well-earned retirement.

Increased H.T. Battery Prices

With the approval of the Central Price Regulation Committee the Association of Radio Battery Manufacturers give notice that the retail prices of all the Association's batteries are increased by 20 per cent. as from April 1, 1942.

The following are typical revised prices for popular types of H.T. batteries, all including purchase tax.

60 v. 5s. 7d. 120 v. 11s. 1d.
108 v. 9s. 10d. 126 v. and bias 13s. 7d.

The Television Society

The new issue of the Society's journal, which has just been issued, contains a complete report of Dr. Bosch's lecture on the "Augetron" with much additional matter omitted from the lecture.

It is in fact a monograph on the subject, and is available to non-members of the Society at a price of 5s. net. Applications should be sent to the Editor, Mr. W. G. Mitchell, Lynton, Newbury, Berks.

Although the Society's activities have been greatly curtailed by the war, they are looking forward to re-opening fresh premises as soon as opportunity permits, and the hon. general secretary, Mr. J. J. Denton, would be pleased to answer inquiries from any readers interesting in furthering television developments after the war. His address is 17 Anerley Station Road, S.E.20.

OBITUARY

We regret to have to record the deaths of:

MR. P. KELLY, Managing Director of the Edison Swan Co. Mr. Kelly was originally with the G.E. Co. of America and later with the I.G.E. of Schenectady. In 1920 he was engaged by the B.T.H. Co. as manager of their Bombay Office, but returned to the I.G.E. before taking charge of the Merchandising Sales Dept. of the B.T.H. in London. He was appointed Managing Director of Ediswan in 1928 and was also on the Council of ELMA and Chairman of the C.M.A.

MR. P. K. TURNER, the first editor of *The Wireless Trader*, and well-known in his connexion with Messrs. Hartley Turner, the "quality" amplifier and loudspeaker manufacturers. Mr. Turner was a member of the I.E.E. and the author of many articles on radio. He was also Editor of *Experimental Wireless* for a short time.

MR. J. C. WILSON, formerly with the Baird Company, was employed by the Hazeltine Service Corporation of America at the time of his death in December, 1941. His textbook on "Television Engineering" which was first published in 1937 was the first comprehensive book on the subject. Mr. Wilson had many friends in this country who will learn of his death with surprise and regret.



MULTICORE SOLDERS LTD.
BUSH HOUSE, LONDON, W.C.2

Tem : 5583/4

AVOID DANGER of H.R. or DRY JOINTS

The experiences of the leading manufacturers of Radio and Electrical Equipment have shown that only by using ERSIN MULTICORE SOLDER WIRE, which contains three cores of non-corrosive Ersin Flux (A.I.D. Approved), and the correct soldering technique, can they ensure that H.R. or Dry Joints are avoided.

If you are engaged on Government Contracts write for Technical information and free samples of Ersin Multicore. For the present, supplies of Ersin Multicore are restricted to such firms, and the Ministries.

IN THE NATIONAL INTEREST. Even if you do not yet enjoy the advantages of Multicore; in the National interest endeavour to use an alloy containing a lower tin percentage. We are glad to give technical assistance in overcoming difficulties.

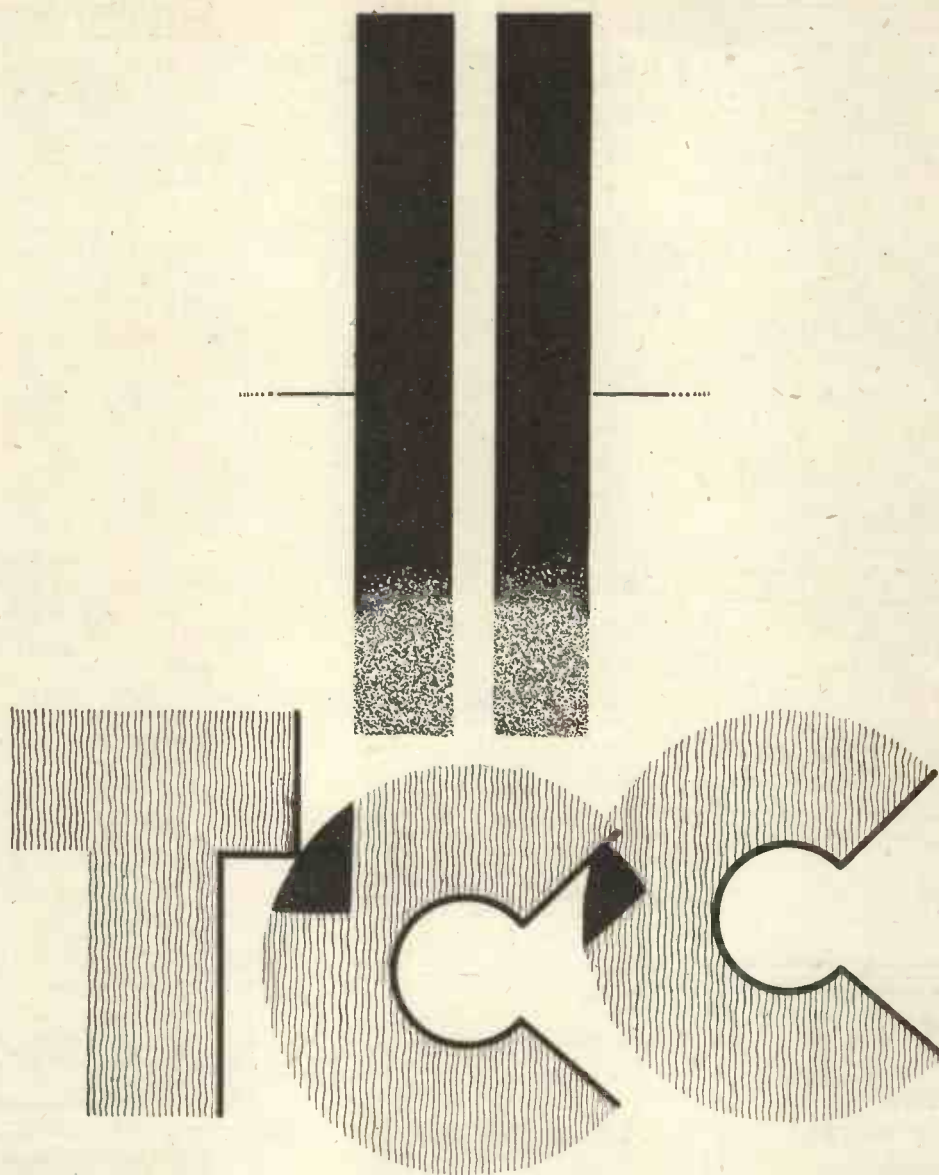

**PRE-EMINENT IN PEACE
INDISPENSABLE IN WAR**

ADVERTISEMENT OF THE TELEGRAPH CONDENSER CO., LTD.

ELECTRADIX

A.C./D.C. MAINS MAGNETS, 2 wound poles, 110 or 220 volts, 5/6. Small 12-volt solenoids, 2 in. x 1/2 in. plunger, 6/6.

FRACTIONAL H.P. MOTORS, D.C. 50 volts shunt, 1/20 h.p., K.B., 2,000 revs., 24/-; 50/70 volts shunt, 1/6 h.p., Crypto, 1,500 revs., 27/6; 110 volts shunt, 1/12 h.p., Croydon, 2,500 revs., 26/-; 110 volts shunt, 1/2 h.p., Maudslay special, 4,000 revs., 45/-; 220 volts shunt, 1/12 h.p., Croydon-Wilson, 2,400 revs., 30/-; 240 volts shunt, 1/3 h.p., Wagner, 1,440 revs., 55/-; 110 volts shunt, 1/6 h.p., Keith B., 1,250 revs., geared to 80, 45/-.

FRACTIONAL A.C. 30 volts, 1/100 h.p., centimidget induction, 58 revs., 15/-; 220 volts, 1/25 h.p., 2,800 revs., 55/-. Self-start induction, 230 volts, 1/2 h.p., new Higgs, 84/6.

DYNAMOS BARGAINS. Rotax, 6/12 volts 8 1/2 amps., D.C., 3rd brush size, 8 in. x 4 1/2 in., 11 lb., cost £10, unused, 15/- (carriage 2/- extra). G.E.C. Double-current Dynamos, 6 volts and 600 volts, ball-bearings, 17 lb., as new, 25/- (carriage 2/6 extra). Charging Dynamos, 16 volts, 15 amps., Leitner, 1,500 revs., 75/- ALTERNATOR.—Perm. Magnet Alternator. Hand drive, 80 volts, 25 m/a. Useful tester, 10/6. 8-WAY Lucas-Rotax Switch boxes, 8 levers and fuses for charging, etc., 3/6. 6-way Push Button, R.A.F. switches, 2/9.

Please add postage on mail orders and send stamp for replies to enquiries.

ELECTRADIX RADIOS

19, Broughton St., Queenstown Rd., London, S.W.8

Phone: Macaulay 2159.

RADIO**ENGINEERING AND TELEVISION**

Complete Postal Courses of Instruction. Recommended to all who desire to obtain a thorough technical and practical knowledge.

Apply —

BRITISH SCHOOL OF TELEGRAPHY LTD.
179, Clapham Road, London, S.W.9.
(Estd. 1906)

Varley**Quality Components**

I.F. TRANSFORMERS
WIRE WOUND RESISTANCES
L.F. CHOKES & TRANSFORMERS
MAINS TRANSFORMERS
DELAY SWITCHES

Varley (Prop. Oliver Pell Control Ltd.)
Cambridge Row Woolwich, S.E.18

LONDEX for RELAYS

FOR A.C. AND D.C.
All types, including Time Delay Relays, High Sensitive Relays, Synchronous Process Timers and complete Control Plants. Synchronous Time Delay Relay PRL (as illustrated).

Ask for leaflet SPN/EO

**LONDEX LTD**

Manufacturers of Relays

Anerley Works, 207 Anerley Road,
London, S.E.20. Phone: SYDenham 6258/9

GALPINS ELECTRICAL STORES

21, WILLIAM STREET, SLOUGH, BUCKS.

Telephone: Slough 20855.

Cash or C.O.D.

ELEC. LIGHT CHECK METERS, small, late type, good makers, fine condition, electrically guaranteed, 200/250 volts, 50 cy., 1 ph. A.C. 5 amp., 10/-; 10 amp., 12/6; post 1/-.

D.C. ELEC. LIGHT CHECK METERS, 200/250 v., 5 and 10 amps., 7/6, post 1/-.

AUTO CHARGING CUT OUT AND VOLTAGE REGULATOR, ex-R.A.F., suit any dynamo up to 20 v. at 15 amps., fully adjustable, with wiring instructions, complete in metal case, 3/6, post 9d.

BLOCK CONDENSER, large size. 1 MF., 4,000 v. working, 15/-, carriage 2/-.

2 kw TRANSFORMER, complete with clamps, suitable for rewinding, 25/- each; 1 kw. ditto, 17/-, both carriage forward.

DYNAMO for lighting or charging, shunt wound and interpole, output 110 volts 66 amps., price £20, carriage forward.

HIGH TENSION TRANSFORMER, input 110/220 v., 50 cycle, single phase; output 45,000 volts at 7 milliamperes, in first-class condition, small portable type. Price £12 10 0, carriage paid.

D.C. MOTORS LAMINATED fields, approx 1/2 h.p., 110/210 volt. Price 20/-, carriage 2/-.

AUTOTRANSFORMER, size 2,000 watts, tapped, common, 100, 200, 220 and 240 volts. As new. Price £6 5 0, carriage paid.

MILLIAMPERE METERS, by "Weston" and "Turner," 2" dia., Flush mounting, moving coil, reading 0-5 M/A, zero adjusting. Price £3, post free.

MILLIAMPERE METERS, exactly as above but reading 0-50 M/A. Price £2 10 0, post free.

1 kw. AUTO TRANSFORMER, wound with 16 gauge D.C.C. Wire, in new condition, tapped 0-75-175-200-220 and 240 volts, wire and stampings worth the cost. Price £2 10 0, carriage paid.

MOTOR BLOWERS, 2" disc outlet, for 110 v. D.C., or will work on 150 volt A.C., small size, Ball Bearing, in perfect working order. Price £2 10 0, carriage paid.

MORSE KEYS, high grade ex Naval service keys, condition as new, very solid construction, good contacts. Price 15/-, post free.

20 volt D.C. COMPOUND WOUND MOTORS, 1/20 H.P., speed 2,000 R.P.M., totally enclosed, Ball Bearing, a really high-class job, in new condition, ampr. 3-75, make good dynamo. Price 30/-, carriage paid.

X RAY TRANSFORMER, in oil-filled tank, input 120 volts, 50 cycles, single phase; output 80,000 volts at 10 K.W., also fitted winding at 12 volt for Coolidge Tube heating, in first-class condition. Price £15, carriage forward.

A.C. INDUCTION MOTOR, by Crypto, 230 volt, 50 cycle, 1 PH, Ball Bearing, one horse power, speed 1,450 R.P.M., in first-class condition and working order. Price £10, carriage paid.

ROTARY CONVERTOR, D.C. to D.C., input 220 volts; output 12 volts at 50 amps., D.C., Ball Bearing, condition as new. Price £10, carriage forward, or 17/6 passenger train.

DOUBLE OUTPUT GENERATOR, maker "Crypto," shunt wound, outputs 60 volts at 5 amps. and 10 volts at 50 amps., Ball Bearing, condition as new. Price £10, carriage forward, or passenger train 17/6.

ALTERNATOR, output 220 volts, 50 cycles, I.P.H., at 180 watts, do 1 amp. easily, speed 3,000 R.P.M., self exciting, condition as new. Price £10, carriage paid.

TRANSFORMER, input 230 volts, 50 cycles, I.P.H.; output 1100-0-1100 volts at 220 M/A; also 6 volts C.T. Three times, earth screen, wound to B.S.R., weight 32 lbs. Price £6 10 0, carriage paid passenger train.

Classified Announcements

The charge for miscellaneous advertisements on this page is 12 words or less 3/-, and 3d. for every additional word. Single-column inch rate displayed, £1. All advertisements must be accompanied by remittance. Cheques and Postal Orders should be made payable to Hulton Press, Ltd., and crossed, and should reach this office, 43, Shoe Lane, London, E.C.4. not later than the 15th of the month previous to date of issue.

LOUDSPEAKERS

3,000 SPEAKERS P.M. and energised 4" to 14", including several Epoch 18". Sinclair Speakers, Pulteney Terrace, Copenhagen Street, N.1.

LOUDSPEAKER repairs, British, American, any make, 24-hour service; moderate prices.—Sinclair Speakers, Pulteney Terrace, Copenhagen Street, N.1.

MORSE EQUIPMENT

FULL range of Transmitting Keys, practice sets and other equipment for Morse training.—Webb's Radio, 14, Soho Street, London, W.1. Phone: GERard 2089.

RADIO MAP

WEBB'S Radio Map of the World enables you to locate any station heard. Size 40" by 30" 2 colour heavy Art Paper, 4/6, post 6d. Limited supply on Linen, 10/6, post 6d.—Webb's Radio, 14, Soho Street, London, W.1. Phone: Gerrard 2089.

TELEVISION

GOOD selection of shop soiled Television sets by Baird, Cossor and Murphy. Details on request.—A.C.S. Radio, 44, Widmore Road, Bromley.

PORTABLE double-beam C.R. oscillograph, similar to Cossor 339, high sensitivity, wide-band amplifiers, linearised time-base, corrected tube, complete unused. Highest offer above £50 secures. Box No. 648. *Electronic Engineering*.

TUITION

PRACTICAL Radio Postal Courses, coaching for I.P.R.E., R.A.F. Location, and A.I.D. exams; booklet free.—Secretary, I.P.R.E., Bush House, Walton Avenue, Henley-on-Thames.

WANTED

ALL TYPES of used Radio Sets, Radio and Electrical accessories. Bought for cash. University Radio, 22, Lisle Street, W.C.2. Phone: GER 4447.

WE OFFER cash for good modern Communication and all-wave Receivers.—A.C.S. Radio, 44, Widmore Road, Bromley.

VALVES AND SPARES

NATIONAL UNION, PHILCO, TUNGSRAM ETC. VALVES.

Philco replacement Coils, Volume Controls, Condensers, Resistances etc.

No lists. Please send stamp and state requirements.

E. H. ROBINS, TRADING CO., LTD.
32, City Road. Cardiff.

FOYLES

BOOKSELLERS TO THE WORLD

New and secondhand Books on every subject.

Catalogues Free. Books Bought.

113-125 Charing Cross Road, London, W.C.2

Tele: Gerrard 5660 (16 lines). Open 9-6 inc. Sat.

CHAINS

Also HOOKS, RINGS, etc.

Write for A. J. PRATT & SONS, Ltd.
Catalogue E. 7 WOODBRIDGE STREET, E.C.1

**SLYDLOK**

VIBRATION PROOF FUSES

SWITCH OR FUSE EDWARD
PANELS - SWITCH
PANELS FUSEBOARDS
WILCOX & CO LTD

SHARSTON RD - WYTHENSHAW - MANCHESTER

dm 679

ROLA

LOUD
SPEAKERS

THE WORLD'S FINEST REPRODUCERS

TRANSFORMER
LAMINATIONS

Core Widths $\frac{3}{16}$ " to $\frac{1}{2}$ " (E's and I's.)

EIGHT STOCK SIZES

A Comprehensive Bulletin together with details of Associated Covers and Clamps with design data will be sent to manufacturers on request.

BRITISH ROLA LIMITED

MINERVA ROAD · PARK ROYAL · N.W.10 · WILlesden 4322

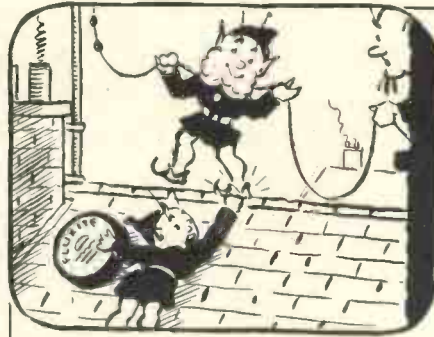

THE "FLUXITE
QUINS" AT WORK.
"Don't worry—I'll
mend it," cried EH,
"Done worse things
than this in my day.
"Where on earth is
that lad
"With the FLUXITE,
begad?"
"You're standing on
him!" shouted they.

See that FLUXITE is always by you—in the house—garage—workshop—wherever speedy soldering is needed. Used for 30 years in government works and by leading engineers and manufacturers. Of Ironmongers—in tins, 4d., 8d., 1/4 and 2/8. Ask to see the FLUXITE SMALL-SPACE SOLDERING SET—compact but substantial—complete with full instructions, 76. Write for Free Book on the art of "soft" soldering and ask for Leaflet on CASE-HARDENING STEEL and TEMPERING TOOLS with FLUXITE.

To CYCLISTS! Your wheels will NOT keep round and true unless the spokes are tied with fine wire at the crossings and SOLDERED. This makes a much stronger wheel. It's simple—with FLUXITE—but IMPORTANT.

THE FLUXITE GUN puts FLUXITE where you want it by a simple pressure. Price 1/6, or filled 2/6.

FLUXITE LTD. (DEPT. T.V.),
BERMONDSEY ST., S.E.1.

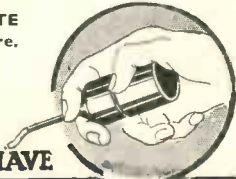

ALL MECHANICS WILL HAVE

FLUXITE

IT SIMPLIFIES ALL SOLDERING

"AFTER THE WAR" TELEVISION

With the coming of Peace, and backed by the Technical advances that have resulted from the war years, TELEVISION will again spring to life and offer opportunities, as never before, to the trained man.

Now is the time to prepare for this new "market." Our Home-study "Television" Course is comprehensive, up-to-date and suitable both for the amateur and experienced Radio Engineer.

We definitely guarantee
"SATISFACTION—OR REFUND OF FEE"

You are advised to send 2½d. stamps for (post free) details of this special Television Course and subsequent matter immediately, to investigate its possibilities. Details will also gladly be sent of A.M.I.E.E. and A.M.Brit.I.R.E., Examinations and other courses in all branches of WIRELESS ENGINEERING, including particulars of our special SHORT WAVE and RADIO SERVICING COURSES which are in such demand.

BRITISH INSTITUTE OF ENGINEERING TECHNOLOGY
Principal: Prof. A. M. Low.

337, Shakespeare House, 17/19, Stratford Place, London, W.1.

"COSMOCORD"

CRYSTAL PICK - UP



FOR CLARITY AND TONE

LICENSED BY BRUSH CRYSTAL CO., LTD., under Brit. Pat. Nos. 366,252 and 454,595

Retail Price 30/- Plus Tax

Wholesale Trade only supplied.

SOLE SELLING AGENTS
SALE, TILNEY & Co., Ltd.,
3, LLOYD'S AVENUE, LONDON, E.C.3



**BOBBINS
FORMERS
TUBES &
SHROUDS**

FLUXITE

ARMAND TAYLOR & CO.
FACTORY YD. MANWELL B'WAY, W.7

PANILAX

REGISTERED TRADE MARK

BONDED PAPER INSULATION OF HIGH MECHANICAL STRENGTH AND MOULDED RESIN WITHOUT FILLER. BOTH HAVE EXCELLENT ELECTRICAL PROPERTIES.

MICANITE & INSULATORS
COMPANY LIMITED

WALTHAMSTOW LONDON E.17



Telephone: LARKSwood 1044 (Pte. Br. Exch.)



Schools, Instructors and those training as operators will find a wide range of Morse Equipment in stock at Webb's Radio. Some of this equipment is described here, including a new American type Key at 8/6, and two very useful Audio Oscillators. Many other lines are generally available. Send us your requirements or call at our depot, 14, Soho Street.

1 AUDIO OSCILLATORS. Model O.A.1. For private use. This drives one or two pairs of 'phones—gives 1,000 cycle note and is operated from A.C. mains. The cost including two valves is £2/5/-. Model O.A.2. Produced for class training, it has alternative outputs for 20 or 50 pairs of high-resistance headphones, or for two loudspeakers. The note is variable in pitch and volume. Entirely A.C. mains operated. Supplied complete for £7/10/-.

2 AMERICAN TYPE MORSE KEY. A British-made version of this popular key is made available at very small cost. A well-balanced key, considerably lighter in operation than the ordinary type. Black, crackle finish, metal base. Price 8/6.

3 MORSE KEYS. Our range also includes British-made Bar-type Keys of standard "Post Office" pattern. We list three types which are available in quantities from stock. SCHOOL pattern in chromium-plated brass on polished wood base, at 8/6. HEAVY DUTY model in solid lacquered brass on wood base, 15/-. SPECIAL Model, illustrated, with heavy contacts back and front, lacquered brass, wood base, 28/-.

4 HEADPHONES. Webb's have available a special light-weight headphone manufactured for training purposes by Messrs. S. G. Brown solely for Webb's at 17/6 a pair. All other popular headphones are available from stock including the famous Brown's "A" adjustable reed, at 5/6.

WEBB'S RADIO, 14 SOHO STREET, OXFORD STREET, LONDON, W.1

Telephone: GERrard 2039. Hours of Business: 9 a.m. to 5 p.m. Saturday, 9 a.m. to 12 noon.