

Electronic Engineering

INCORPORATING ELECTRONICS, TELEVISION AND SHORT WAVE WORLD

PRINCIPAL CONTENTS

' WAVEFORM NUMBER '

Harmonic Analysis of Waves
Waveforms Encountered in Television
Data Sheets : Television Waveforms
Waveforms of Vibrators
German Aircraft Radio Equipment

2/- JUNE, 1942

FREQUENTITE

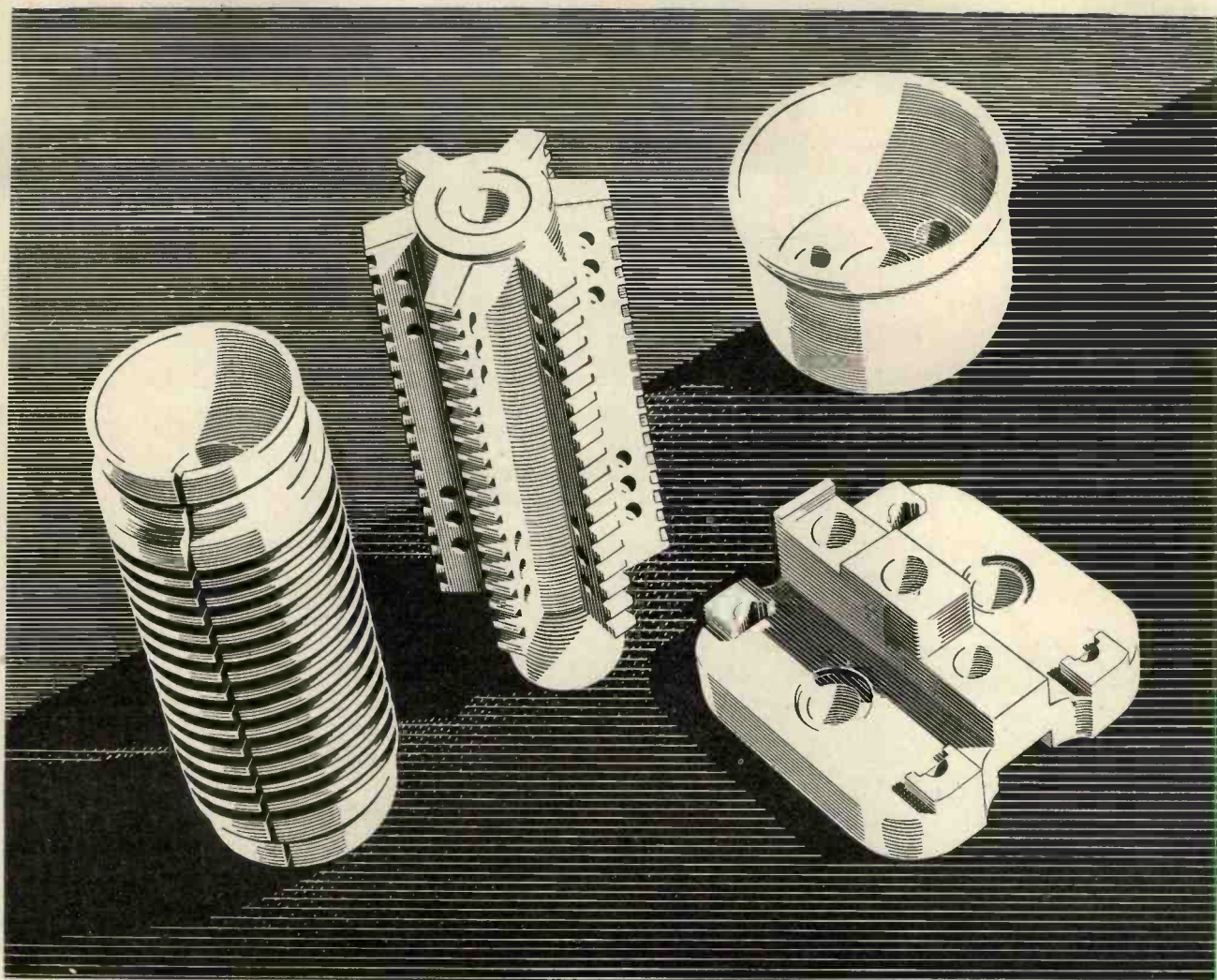

THE PIONEER BRITISH-MADE LOW LOSS CERAMIC

THE DEMAND for Frequentite, which possesses outstanding properties of Low Loss and High Mechanical Strength, continues to increase rapidly—*and to be met*. Production capacity has been stepped up over a period of years by extensions to plant, the employment of

specialised new equipment, and progressive improvements in manufacturing technique. Bulk supplies of the most intricate designs can be delivered promptly, and all manufacturers are invited to write for Catalogue No. S.P.10.

STEATITE & PORCELAIN PRODUCTS LTD.

Head Office :

Telephone : STOURPORT 111.

STOURPORT-ON-SEVERN, WORCS.

Telegrams : STEATAIN, STOURPORT.

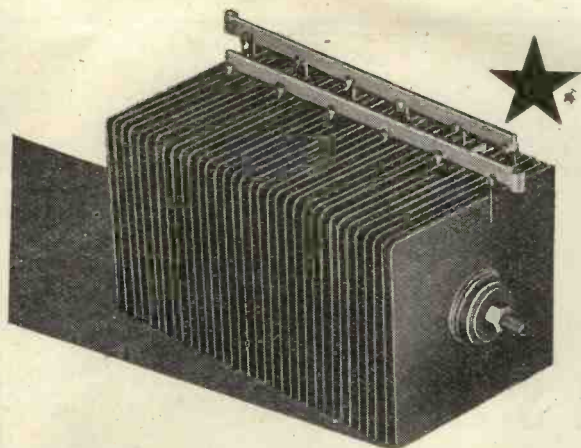

- ★ **Metal construction**—for strength and durability.
- ★ **Electronic action**—nothing to wear out.
- ★ **Unlimited life**—proved by 15 years' experience of operation.
- ★ **80 % efficiency**—from $\frac{1}{4}$ th load up to full load.

Westinghouse
Metal Rectifiers

Send 1/- to Dept. E.c.
 for descriptive pamphlet No. 11

Westinghouse Brake & Signal Co. Ltd. Pew Hill House,
 Chippenham, Wilts.



TELCON CABLES

for
**HIGH
 FREQUENCY
 TRANSMISSION
 and RECEPTION**

Full particulars of all Telcon Products from :
**THE TELEGRAPH CONSTRUCTION
 & MAINTENANCE CO. LTD.**
 Head Office : 22, Old Broad Street, London, E.C.2
 Telephone : London Wall 3141
 Temporary Address : Blackstone, Redhill, Surrey
 Redhill 1056

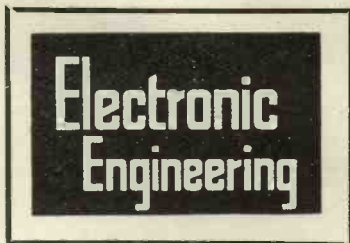

JUNE, 1942.

Volume XV.

No. 172.

CONTENTS

	PAGE
Editorial	7
German Aircraft Radio Equipment	8
Harmonic Analysis of Waves	13
Television Waveform	19
Data Sheets, Nos. 29, 30 and 31	21
Suppression of H.F. Interference	28
Waveforms of Vibrators	32
Automatic Analysis of Ultra Low Frequency Transients	34
Notes from the Industry	37
R.C. Oscillator (Leland Instrument Co.)	38
Abstracts of Electronic Literature	40
Book Reviews	42



LEADERSHIP

To radio technicians the name Mazda has always been synonymous with all that is progressive in valve development.

In design and performance MAZDA RADIO VALVES will always merit their title to leadership . . . the proud position they have held so long.



MAZDA
RADIO
VALVES

Mazda Radio Valves are manufactured in Gt. Britain for the British Thomson-Houston Co. Ltd., London and Rugby, and distributed by

THE EDISON SWAN  ELECTRIC CO. LTD.

155 CHARING CROSS ROAD, LONDON, W.C.2

For full particulars write to Technical Sales Department.

Electronic Engineering

PROPRIETORS :

HULTON PRESS LTD.,

EDITOR

G. PARR.

EDITORIAL, ADVERTISING AND PUBLISHING OFFICES, 43-44, SHOE LANE, LONDON, E.C.4

TELEPHONE:
CENTRAL 7400

Monthly (published last day of preceding month) 2/- net. Subscription Rates :
Post Paid to any part of the World—
3 months, 6/6; 6 months, 13/-; 12 months, 26/-. Registered for Transmission by Canadian Magazine Post.

TELEGRAMS :
HULTONPRES LUD
LONDON.

Electronics Group

IN January last a meeting of certain interested members of the Institute of Physics under the chairmanship of Dr. J. D. COCKROFT was held to consider the formation of an Electronics Group, and at a second meeting at the R.I. in May it was announced that the Board of the Institute had approved the formation of such a Group, which is now duly constituted.

Membership of the Group is not necessarily confined to members of the Institute or to those whose qualifications entitle them to become members. By becoming a supporter of the Institute at a nominal fee of 10s. 6d. per annum any radio engineer of standing is entitled to attend the meetings of the Group and will also enjoy many of the other advantages of membership of the Institute.

Dr. H. LOWERY, Principal of the S.W. Essex Technical College, Walthamstow, E.17, is acting as temporary Hon. Secretary, and further particulars will be issued in due course.

Needless to say, the formation of such a group under the aegis of the Institute of Physics has our warmest support. It is evidence of the growing importance of the science and its close relationship to physics that such an authoritative body should have provided facilities for discussion of electronic problems among those whose work is becoming more and more interlinked with that of the radio and communications engineer.

The journal is in no way officially connected with the Group, or, indeed, with any other scientific body, but it

has the common aim of furthering the knowledge of electronics and allied subjects, and in this it will co-operate cordially with them.

There is no research laboratory in the country worthy of the name that does not already rely on electronic apparatus, whether in the form of a cathode-ray tube, amplifier, or even a neon stabiliser. Cathode-ray tube equipment has now become so standardised that it can be connected into a circuit with as little trouble as a voltmeter and modern amplifiers can be relied on to give consistent results over a period of years.

The requirements of the research worker in amplifiers have not been well catered for in the past and too many are still in the position of having to pause in their work to design or make up a circuit to suit their particular job.

What would a physicist say if he had to design and assemble a micro-

scope or micrometer for his own use when small quantities had to be measured? An amplifier is a magnifier of small quantities, often within well-defined limits and conditions, and it should be possible to have a range of standard amplifiers with known performance that would form as much a part of the laboratory equipment as a microscope or projector.

The standard research amplifier would have a calibrated gain and response characteristic and would be available in several types to suit various supplies and operating conditions. It would have the advantage that the design would not be hampered by economic or size considerations as in the case of broadcast amplifiers, and if a laboratory did not wish to buy a commercial type it could assemble one from published data with the certainty that the results obtained from it would be comparable.

It is in this uniformity of results that the advantage of the standard amplifier lies. The comparison of experimental work is obviously simplified if the workers are using the same tools and many discrepancies requiring further investigation would be eliminated.

Laboratories already use similar micrometers—why should they not use similar amplifiers? We put forward the suggestion for the consideration of the Electronics Group who are well qualified to advise the industry and, if necessary, draw up a specification and design.

URGENT—PRIORITY

You'd be surprised at the number of "indispensable" books and papers that are never used. Some of them are out of date under present conditions—some of them have information that is duplicated elsewhere.

If you have not already sorted out the books in your bookcase, please make it a priority job. One day earlier makes all the difference to the war effort.

Your local council will collect bulky packages at no expense to yourself.

Make a memo. and mark it : **URGENT. PRIORITY.**

Paper and cardboard salvage is vital to the war industry—save all you can.

VIEWS OF HEINKEL IIIH RADIO EQUIPMENT

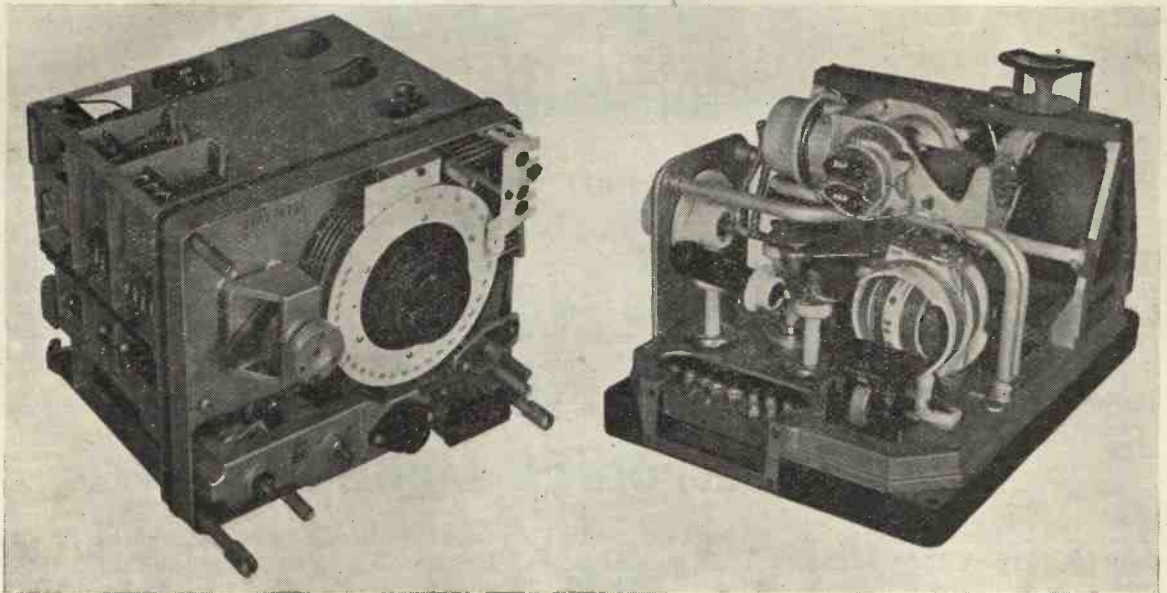

Above : Left : Receiver chassis with front removed to show tuning dial and disks for "spot" frequency tuning. The rotor plates of the condenser are mounted on a ceramic spindle running in ball-bearings. Right : Aerial tuning unit showing ceramic former for variometer. The fairlead is live and is supported by the massive porcelain insulator shown at the back of the unit.

Below : Transmitter chassis dissected to show the iron-cored variometers (left hand unit) and the valveholders (right hand unit). The two light aluminium castings are the sole framework of the chassis. Note the plug and socket connexions between the two parts of the chassis (extreme right hand edge and left hand edge).

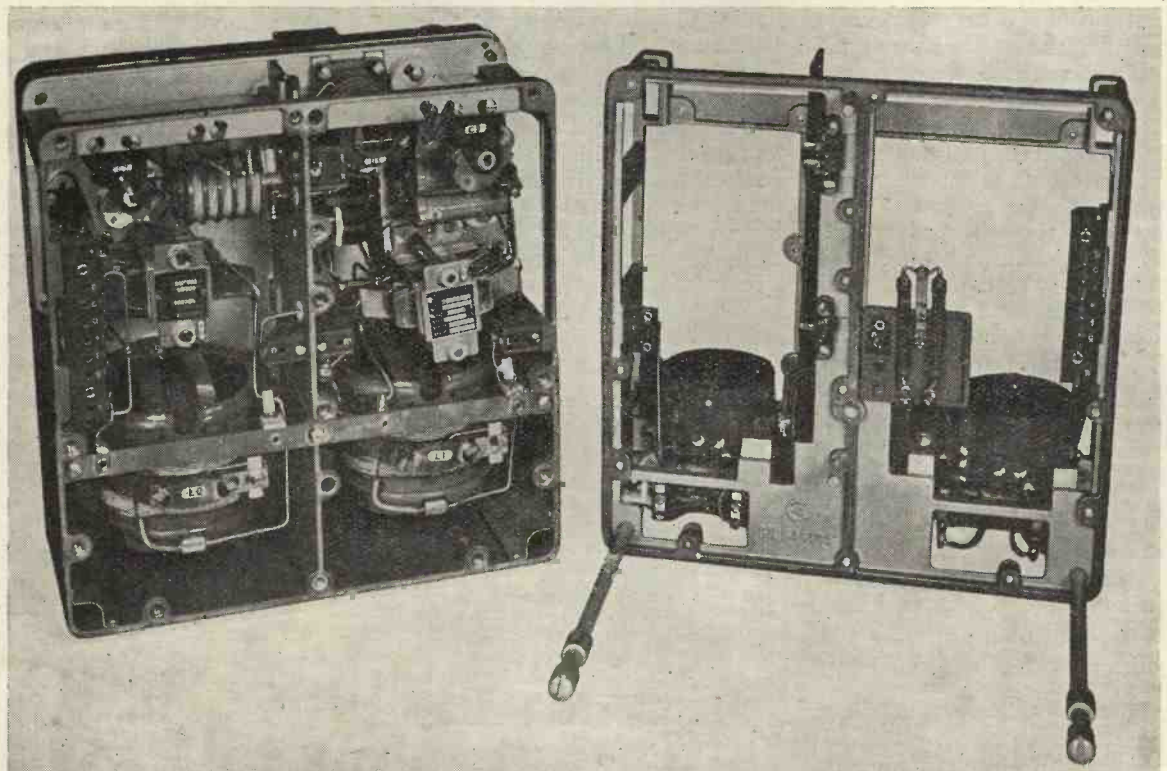

German Aircraft Radio

The following Information is reproduced by permission of the Ministry of Aircraft Production from official reports on the various types of radio equipment found in German Aircraft.

Notes on some types of equipment were issued earlier in the war, and this report embodies those together with much additional detail

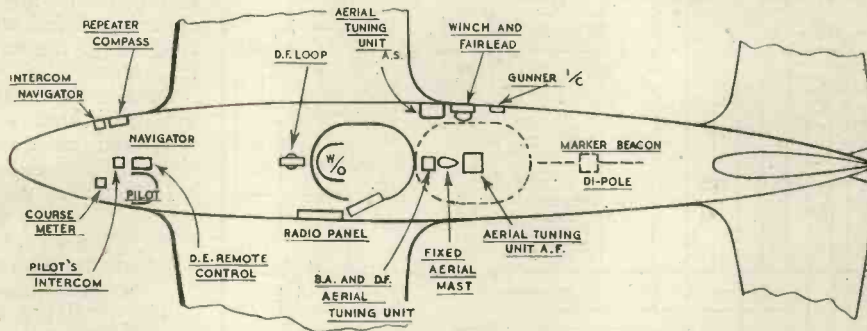

Fig. 1. Diagram showing layout of radio and intercommunication equipment in the Heinkel 111H.

EQUIPMENT F.U.G. 10

THIS is the most complete equipment which was standardised on bombers and reconnaissance machines such as the Heinkel 111H and later models and which provides all the facilities considered necessary for aircraft of this class.

Technically the radio equipment is sound and well planned, but not advanced in design. The mechanical workmanship though good is heavy and expensive. One feature is that the equipment is exceptionally easy to service and repair. It is panel mounted and weighs approximately 350 lb. complete. The power consumption is 550 w. from a 24 v. battery.

It comprises:

(a) Intercommunication circuits between the four members of the crew with emergency switching between wireless operator and pilot.

(b) Short and long wave intercommunication equipment operating on four spot frequencies in the 300-600 kc/s. band and 3-6 Mc/s. band. The power output is 65 w. and the receivers give 50 mW. output for 1 μ V.

(c) D.F. receiving equipment for the navigator. The loop control is combined with a compass repeater and a course meter on the dashboard gives a rough indication of distances.

(d) Blind approach equipment operating on the same spot frequencies and indicating on the same course meter.

(e) Long wave pulse transmitter (combined with the long wave transmitter) to enable bearings on the aircraft to be obtained on the ground free from night errors.

The layout of the equipment is shown in the diagram of Fig. 1.

Radio Communication Equipment

The short and long wave transmitters are mounted side by side, each consist-

ing of a master oscillator driving two amplifiers in parallel. The same type of valve is used throughout—Telefunken RL. 12, P.35—the rating of which is:

Heater: 12.6 v. 0.68 amps.

Anode: 30W. max. dissipation, 800 V. max.

Screen: 5 W. max. dissipation, 200 V. max.

Max. cathode current 150 mA.

Max. grid current 4 mA.

The circuit diagram is shown in Fig. 2, the essentials of the circuit being common to the long wave transmitter. In both cases the tuning of the oscillator and amplifier tank circuits is carried out by iron-cored variometers ganged together and controlled by a single knob fitted with a vernier scale. The four set frequencies are arranged to lock in position successively as the knob is turned (*see* receiver notes).

Power supply is from a rotary transformer from the aircraft battery, the heaters operating directly from the battery. The short wave transmitter is used for C.W. only, keying being carried out in the grid circuit of the master oscillator stage.

This stage is temperature compensated for frequency stability and gives a variation of 20 parts per million per $^{\circ}$ C. at 5,780 kc/s.

The long wave transmitter as noted in (e) above is also designed to send a series of pulses which are applied to the amplifier grids from an audio unit. For normal operation the transmitter is set to one of the four pre-determined frequencies and adjusted to work on low power. The receiver is similarly adjusted for low sensitivity and the transmitter is then tuned to the ground station by listening for zero beat in the receiver phones. The transmitter is also set to work on low power while the aerial is being tuned by a variometer in

the aerial tuning unit. Pressing the key automatically puts the transmitter on full power.

Receivers

Both long and short wave receivers are similar in design and are super-heterodynes with four "spot" frequencies selected by a cam click device on the main tuning condenser. The tuning controls are ganged and very accurate tuning is possible. The performance of both receivers is of a high order as regards selectivity and sensitivity. The frequency spotting is done by means of four disks mounted on the shaft of the three-gang tuning condenser. Each disk has a notch which engages with a projection on a hinged lever which locates the disk in a fixed position. The hinge pin of the levers is capable of slight movement so that all four disks can be moved simultaneously over a small range, and they can also be operated independently through adjusting screws in the front of the receiver. The transmitters have a similar system for spotting their frequencies.

The circuit is an eight-valve one: r.f. amplifier, frequency changer with separate grid-coupled oscillator, two i.f. amplifiers (140 kc/s. long wave and 1.4 Mc/s. for short wave), anode bend detector, heterodyne oscillator, and output valve.

The heterodyne oscillator is coupled to the grid circuit of the detector and is adjusted to beat at intermediate frequency and 1,000 c.p.s. above or below it. The oscillator is switched on when the receiver is set for C.W., a note filter being also switched in. The long wave receiver has both these features on all the time. The sensitivity of the receiver is adjusted by varying the bias of the r.f. and first i.f. amplifiers. No A.V.C. is used. For low gain, when

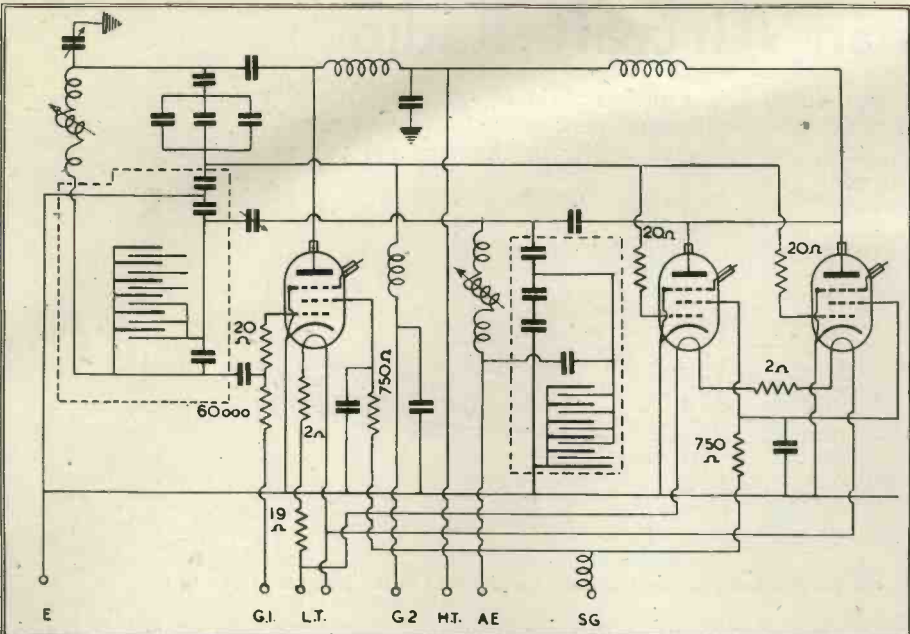

Fig. 2. Circuit diagram of short-wave transmitter. The tuning is carried out by ganged iron-cored variometers.

the transmitter is being tuned, the H.T. negative lead has an extra resistance inserted.

Valves

All eight valves are of the same type, Telefunken RV.12 P 2,000, and are H.F. pentodes taking .068 amps. at 12 v. each. They are perhaps an outstanding feature of the receiver and are small and compact with ring seals and radial contact bases. The valve holders are moulded and entirely enclose the valve, which can only be removed by inserting a screw in a hole in the base and pulling it out of the holder. When used as a triode the suppressor and screen grids are connected to anode.

Aerials

Both fixed and trailing aerials are provided in the machine. These are located at a point remote from the transmitter, necessitating tuning units at the base of the aerial.

Tuning of the units is by remote control from the aerial controller (see on) and the aerials are switched from send to receive by a magnetic vacuum relay

actuated by the keying circuit. Tuning of the aerial is very critical.

The tuning unit for the fixed aerial contains a variometer with switches for selecting the appropriate coil for long or short wave transmission. Movement of the variometer is carried out by Selsyn motor control from the operator's desk. (See Figs. 5 and 6).

The 300 kc/s. variometer is wound on a paxolin former with Litz wire and has an iron dust core to the rotor. The

higher frequency variometer also has an iron dust core, but is wound with copper tape on a ceramic former. The Q of the variometer lies between 100 and 160; the tuning capacity is 50-500 pF. The unit contains four independent matching transformers for transmission and reception on the two wavebands, these transformers being connected to the variometers through concentric cable with an aerial ammeter coupled to the cable by an iron-cored transformer.

Details of the transmitting matching auto-transformers are as follows:
 Wound on dust cores with cheeks 2 in. diameter. Core diam. 1 in.
 Inductance (300 kc/s. band) 107 μ H.
 (3 Mc/s. band) 48.2 μ H.
 "Q" (300 kc/s) 250.
 Resonant frequency of 3 Mc/s. transformer: 4,000 kc/s.
 The receiving auto-transformers are also wound on dust cores.
 Concentric cable impedance is 50 ohms and the aerial 10 ohms.

Trailing Aerial

This is automatically wound and unwound from the control panel. Either the full length or a portion of the length is automatically unwound depending on the setting of the wave-band switch, a small indicator showing the exact nature of the operation.

Various elaborate interlocking devices ensure the correct operation of the aerial and allow for releasing or cutting the wire in emergency.

Components

The receiving and transmitting valves have already been mentioned.

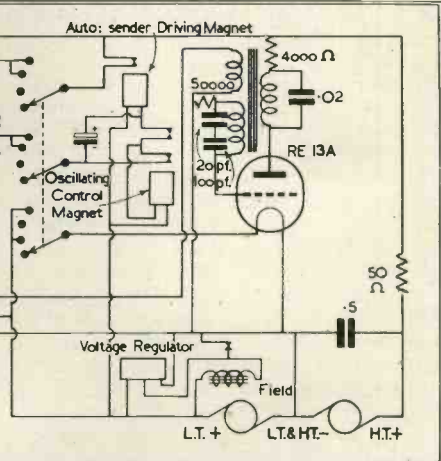
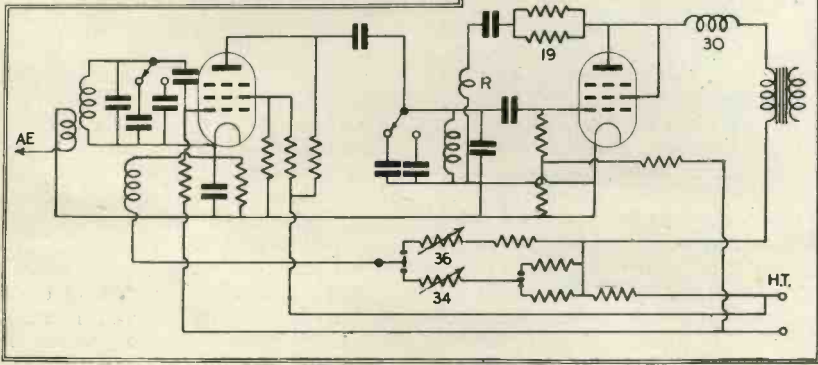

Fig. 3 (above). Circuit diagram of the emergency transmitter used in dinghies. This is crystal controlled—a unique point in the German aircraft equipment.

Fig. 4 (below). Circuit of the h.f. unit of the marker beacon receiver showing reaction arrangements.

Apart from these the mechanical construction and components of both the transmitter and receiver are good. The receiver chassis is assembled in three main castings of magnesium alloy arranged round the central three-gang die cast condenser. The r.f. coils have dust cores with closed iron circuits, the inductance being varied by an adjustable end portion carried on a threaded part of the main moulding (bakelite). The i.f. circuits are set up by means of this adjustment and are coupled by a variable condenser connected between taps on the coils. Tuning is by fixed ceramic condensers. The oscillator for the frequency changer is temperature compensated by ceramic condensers of positive and negative coefficients.

Blind Approach Equipment

This is of the Lorentz type giving visual and aural left-right and marker beacon indications to the pilot. The note frequencies used are 1,150 c.p.s. for main beacon, 700 c.p.s. for inner and 1,700 c.p.s. for outer marker. The keying rhythm is one dot or dash per sec. for main beacon, 2 dashes p.s. for the outer and six dots p.s. for the inner marker.

The main beacon receiver is of the straight type—h.f. amplifier, reacting detector, two i.f. stages and stage for the visual indicator. The marker beacon receiver has a reacting detector and one i.f. stage which feeds into the second i.f. stage of the main beacon receiver. Two preset frequencies are available in the beacon receiver, one of which is 33.3 Mc/s. Both

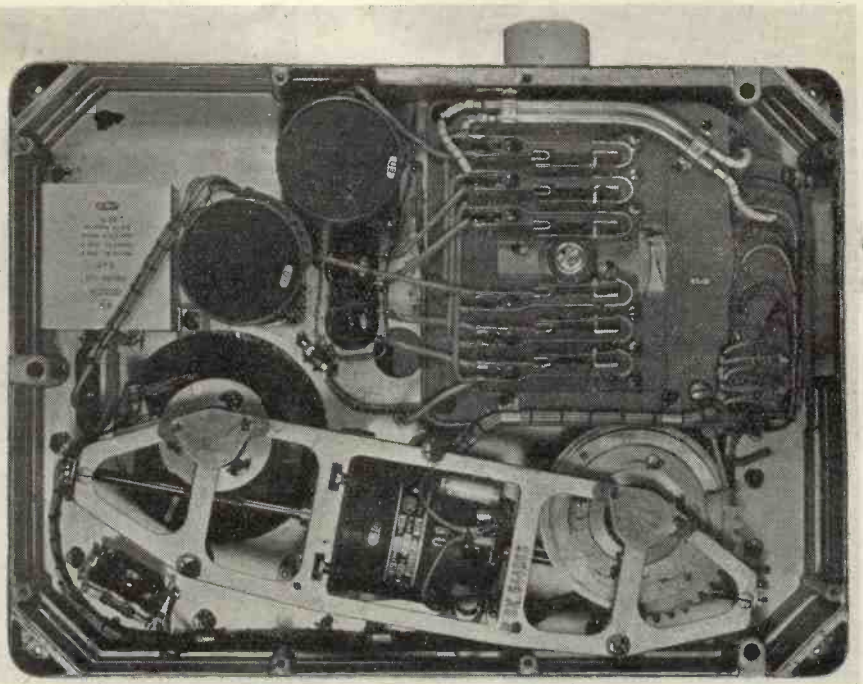

Figs. 5 & 6. Control Mechanism for Remote Aerial Units.

Operated from 250 c.p.s. Selsyn motors. The motors and tuning dials are driven through a magnetic clutch to prevent dial calibration coming out of alignment if the knob is turned with the power off. Both variometers are rotated simultaneously and in addition the worm drive operates the wave-change switch. This is operated over a quarter revolution only, the remainder of the revolution being occupied by tuning. The off-normal contacts open when the aerial tuning coil range is between two positions. The photograph above shows the motor and worm drive. The circular black cans hold the matching transformers.

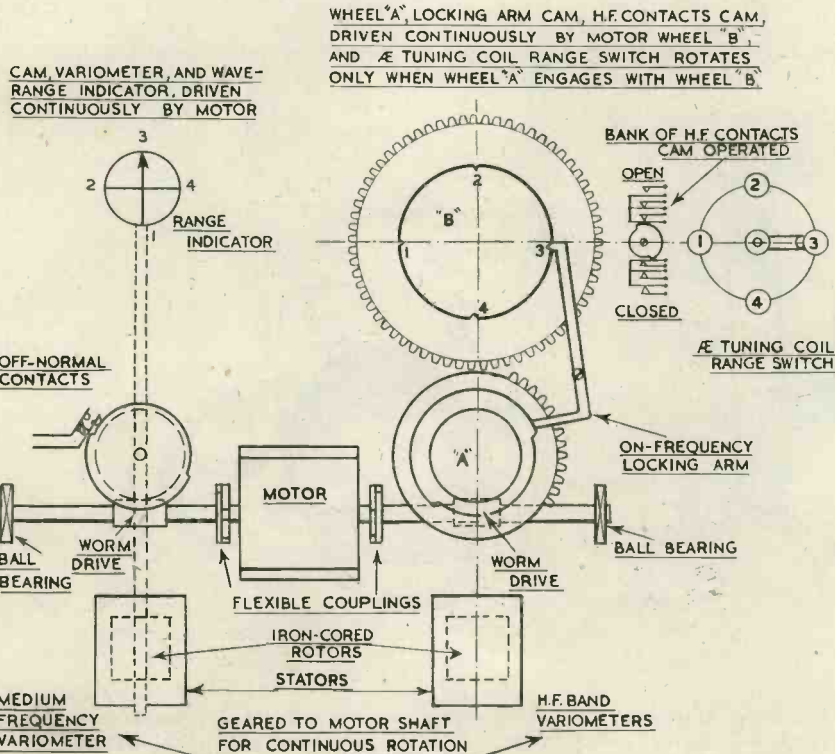

receivers are fed through 180 ohms lines and both the aerials have twin matching units.

A detail of the main beacon h.f. unit is shown in Fig. 4. Gain control is by means of the potentiometers 34, 36 which vary the bias of the h.f. amplifier and at the same time the detector anode voltage to control reaction. Reaction is by means of a winding in the anode circuit of the detector valve coupled to the tuned grid coil. An h.f. choke, 30, feeds h.f. potential back through the reaction winding to earth. The three reaction adjustments are by means of the winding position in regard to the tuned coil, altering the value of the resistance 19, and the controls 34 and 36. The first two are made during manufacture to make the last easy, and on test there was no trace of either electrical or mechanical backlash.

Components

Coils are of bare copper unplated and wound on low-loss bakelite formers. Trimmers are of the piston type with ceramic insulation and air dielectric. H.F. chokes are of the conventional type.

The i.f. transformers have a longer

winding space than usual in comparison with the depth. Shields between primary and secondary are provided.

Valves are Telefunken type NF.2, specially identified for the h.f. and l.f. positions.

The a.f. tuned circuits have dust cored inductances, the core totally enclosing the windings. The condensers are fixed tubular type with mica compression type trimmers.

Direction Finding Equipment

This equipment is a military version of the Telefunken "Aircraft Homing and D.F. Equipment," type P.128 used for civil aviation purposes. The new features are small modifications to the receiver, a repeater compass coupled with the D.F. bearing indicator, the substitution of a dust-iron-cored solenoid for the normal D.F. loop and the connexion of the equipment into the intercommunication circuits of the aircraft.

The wave-band covers 300-1,800 metres in two bands and the equipment provides homing with visual or aural indication, bearing, and all-round communication.

The visual homing sensitivity is .5 mm. deflection for 10° off course at 15μ V/m. Selectivity is 26 db. down at $4\frac{1}{2}$ kc/s from resonance point and 40 db. down at 11 kc/s off resonance. The receiver circuit consists of 3 h.f. stages, two tuned and one untuned, a detector, L.F. stage and R.F. oscillator separately controlled. A.V.C. is provided for homing.

Loop Aerial (Fig. 7.)

The loop aerial has some unusual features which differ from the commercial type. It is wound on a hollow bakelised fabric former 13 in. in

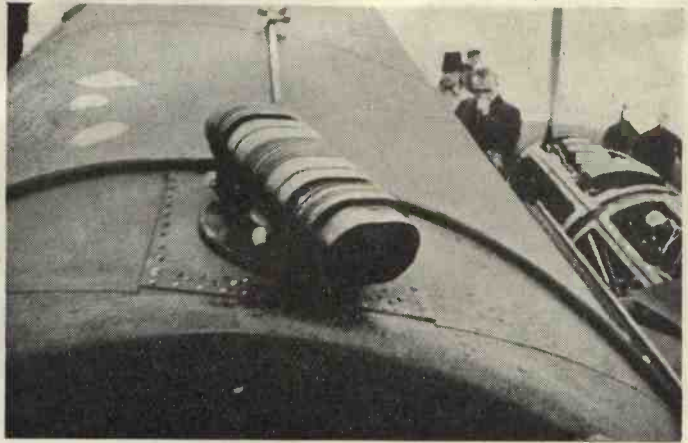

Fig. 7. Photograph of D.F. loop mounted on the fuselage. It has an iron-dust core, which is in the form of ring sections.

length, of oval section 4 in. by 3 in. high. A dust core runs through the centre which is built up of ring sections placed coaxially. The windings consist of eight turns of heavy Litz wire .08 in. diameter wound symmetrically over the length of the former. The winding is divided into two halves which are connected in parallel giving a resulting inductance of 3.2μ H. The loop is connected to the input transformer of the receiver by 30 ohm screened twin cable.

It was found on test that the presence of the iron core increased the pickup of the loop by 10 db. Its permeability is approximately 60.

Remote Control for Loop

The instrument comprises the remote scale and drive for the D/F loop and a repeater compass arranged in a compact unit. The D.F. scale is mounted

at the top of the compass case, with the compass scale concentric and turning with it. A further control enables magnetic deviation to be applied while Q.E. is automatically corrected by a cam mechanism. The information simultaneously available on the instrument is: D.F. bearing with respect to aircraft axis, compass bearing on aircraft axis, D.F. bearing with respect to magnetic North (corrected for Q.E.).

Navigation

The principle of homing flight with visual or aural indication involves the usual combination of non-directional reception with the sense aerial and directional reception with the loop aerial. With aural indication the two cardoids are keyed with the morse letters A and N as usual to produce a continuous dash when the aircraft is on the correct course. The visual homing is

(Continued on page 36)

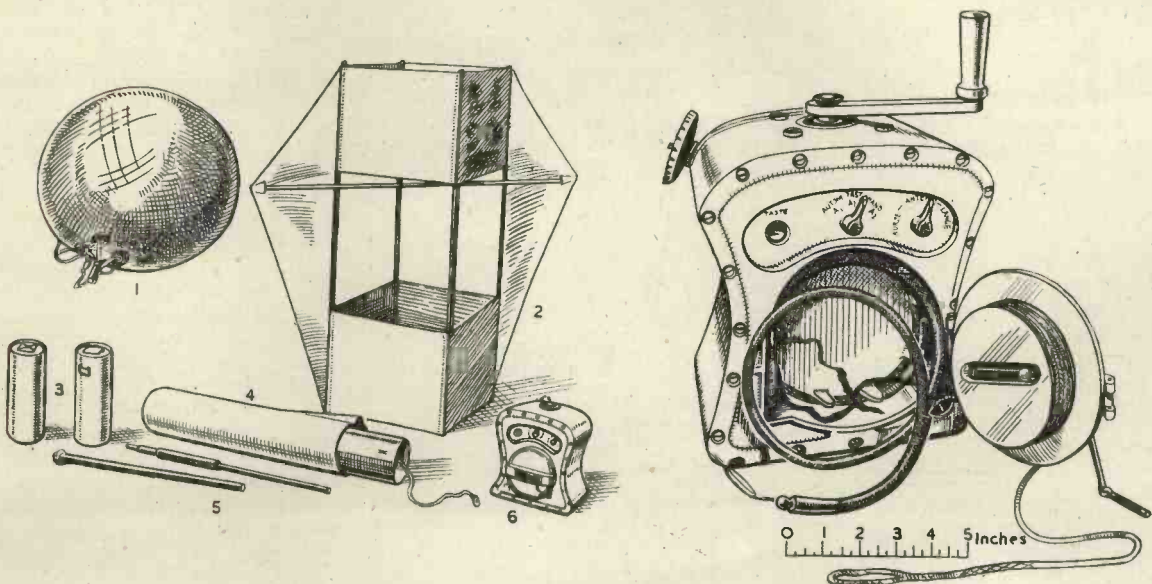

Fig. 8. Emergency transmitting equipment, showing Balloon (1) filled from hydrogen generated in cans (3), which are joined to it by tubes (5). In windy weather the kite (2) is used. The transmitter case (6) is shown enlarged on the right. The case (4) holds the balloon and accessories. See p. 36 for description.

Harmonic Analysis of Waves

Containing Odd and Even Harmonics

By PHILIP KEMP, M.Sc., M.I.E.E.*

THE process of analysing periodic waves into their constituent fundamental and harmonic components is, at the best of times, a tedious operation, and most of the methods at present in use are very laborious when the actual evaluation of the various constants has to be carried out. Many of the methods employed have the additional disadvantage that they are complicated and not readily understood. A method evolved by the writer† was an attempt to expedite calculations of this 'type' and to provide, by means of a schedule, a ready method for the analysis of periodic wave forms. One of the advantages claimed for this method is that it is not necessary to appreciate the underlying theory in order to carry out an analysis, so that the actual labour of computation can be delegated if desired.

The method in question enabled the analysis to be carried out up to and including the 17th harmonic, but *only* for the odd harmonics. Any D.C. component present also had to be eliminated before the analysis could be carried out. The development of rectifiers and, indeed, of all apparatus depending upon a valve action has rendered necessary a method of analysis which shall include the *even* as well as the *odd* harmonics, and also permit the determination of any D.C. component which may be present. Particularly is this necessary when dealing with voltages and currents such as are used in radio and line telephony, where modulated currents containing both odd and even harmonics are the rule rather than the exception. In such cases, the higher harmonics are of relatively small importance, so that the present method is limited to the determination of the fundamental and all harmonics up to the fifth inclusive. Neglecting for the moment the determination of the D.C. component, this necessitates the

evaluation of ten constants, these representing the amplitudes and phase angles of the five components. A minimum of ten points on the wave to be analysed must therefore be known, and it is convenient to choose points at 30° intervals. This gives twelve points instead of ten, it is true, but they are usually the points which are most easily obtained from the graph.

The method consists, then, in measuring the amplitudes of the wave under consideration at 30° intervals, and treating these known values in a way that will now be described.

Commencing from any point a periodic wave may be represented up to the fifth harmonic by the expression

$$y' = Y_0 + Y_1 \sin(\theta + \alpha_1) + Y_2 \sin(2\theta + \alpha_2) + Y_3 \sin(3\theta + \alpha_3) + Y_4 \sin(4\theta + \alpha_4) + Y_5 \sin(5\theta + \alpha_5).$$

The first term, Y_0 , represents the D.C. component, the second term, $Y_1 \sin(\theta + \alpha_1)$, the fundamental, and the other terms the various harmonics, the order being indicated by the subscript.

Before entering upon the separation of the various A.C. components, the D.C. component must first be evaluated and eliminated. In order to do this, the average value throughout a complete cycle must be determined, points above the zero line being assumed to represent positive values and points below the zero line negative values. The average value obtained in this manner represents the D.C. component, and this must be subtracted from the wave, so as to leave only the A.C. components. The resultant average value of these is zero, when taken over a complete cycle.

After this subtraction has been made, the remaining A.C. portion of the wave can be represented by

$$y = Y_1 \sin(\theta + \alpha_1) + Y_2 \sin(2\theta + \alpha_2) + Y_3 \sin(3\theta + \alpha_3) + Y_4 \sin(4\theta + \alpha_4) + Y_5 \sin(5\theta + \alpha_5)$$

where $\theta = \omega t$, ω being $2\pi f$ and t the time in seconds, measured from the arbitrary starting point.

This expression can be expanded as follows:—

$$y = Y_1 \sin \theta \cos \alpha_1 + Y_1 \cos \theta \sin \alpha_1 + \dots + Y_5 \sin 5 \theta \cos \alpha_5 + Y_5 \cos 5 \theta \sin \alpha_5.$$

Since $\alpha_1, \dots, \alpha_5$, are constants, this can be re-written

$$y = A_1 \sin \theta + \dots + A_5 \sin 5 \theta + B_1 \cos \theta + \dots + B_5 \cos 5 \theta,$$

where $A_1 = Y_1 \cos \alpha_1$
 $B_1 = Y_1 \sin \alpha_1$, etc.

Again,
 $A_1^2 + B_1^2 = Y_1^2 \cos^2 \alpha_1 + Y_1^2 \sin^2 \alpha_1 = Y_1^2$

and $Y_1 = \sqrt{A_1^2 + B_1^2}$.

Similarly,
 $Y_2 = \sqrt{A_2^2 + B_2^2}$, etc.

Also $B_1 = Y_1 \sin \alpha_1$
 $\frac{B_1}{A_1} = \frac{Y_1 \sin \alpha_1}{Y_1 \cos \alpha_1} = \tan \alpha_1$

and $\alpha_1 = \tan^{-1} \frac{B_1}{A_1}$.

Similarly,
 $\alpha_2 = \tan^{-1} \frac{B_2}{A_2}$, etc.

(Care should be taken in evaluating the angle α , in order to ascertain in which quadrant it is. If both A_1 and B_1 are positive, then α is in the first quadrant. If A_1 is negative and B_1 positive, α is in the second quadrant. If both A_1 and B_1 are negative, α is in the third quadrant, whilst if A_1 is positive and B_1 is negative, α is in the fourth quadrant. Furthermore, when α is in the second or third quadrant, it is measured from the 180° point.)

In the method of analysis now being described, a series of pairs of ordinates on the wave to be analysed are considered, these pairs of ordinates being equidistantly spaced on either side of the point chosen as the zero. This zero point may be arbitrarily chosen anywhere, but it is usual to choose the point where the resultant wave crosses the X axis, prior to rising in the positive direction.

* Head of the School of Engineering, The Polytechnic, Regent Street.

† "A Practical Method of Harmonic Analysis," "Jour. I.E.E.," vol. 57, supp., p. 85, 1920.

Let one pair of these ordinates be represented by y_θ and $y_{-\theta}$. (Confusion must be avoided owing to the use of subscripts in two ways. The subscript ₃ in Y_3 indicates that it is the *third* harmonic that is being considered, whilst the subscript ₆₀ in y_{60} indicates that it is the ordinate at 60° from the commencing point that is being considered.)

Now

$$\begin{aligned} y_\theta + y_{-\theta} &= Y_1 \sin(\theta + \alpha_1) + \dots \\ &+ Y_5 \sin(5\theta + \alpha_5) \\ &+ Y_1 \sin(-\theta + \alpha_1) + \dots \\ &+ Y_5 \sin(-5\theta + \alpha_5) \\ &= 2 Y_1 \sin \alpha_1 \cos \theta + \dots \\ &+ 2 Y_5 \sin \alpha_5 \cos 5\theta \\ &= 2 B_1 \cos \theta + \dots \dots \\ &+ 2 B_5 \cos 5\theta. \end{aligned}$$

The algebraic sum of each pair of ordinates is equal to a series of terms of the type $2 Y \sin \alpha \cos \theta$, since they are the sums of two sines in every case. Y and α , and therefore B , are constants depending upon the composition of the wave, whilst θ is equal to some known angle, determined by the position of the ordinates chosen.

Next, consider the algebraic difference of the same pairs of ordinates. In this case,

$$\begin{aligned} y_\theta - y_{-\theta} &= Y_1 \sin(\theta + \alpha_1) + \dots \\ &+ Y_5 \sin(5\theta + \alpha_5) \\ &- Y_1 \sin(-\theta + \alpha_1) - \dots \\ &- Y_5 \sin(-5\theta + \alpha_5) \\ &= 2 Y_1 \cos \alpha_1 \sin \theta + \dots \\ &+ 2 Y_5 \cos \alpha_5 \sin 5\theta \\ &= 2 A_1 \sin \theta + \dots \\ &+ 2 A_5 \sin 5\theta. \end{aligned}$$

The algebraic difference of each pair of ordinates is equal to a series of terms of the type $2 Y \cos \alpha \sin \theta$, since they are the differences of two sines in every case, the symbols having the same meaning as before, A_1 being equal to $Y_1 \cos \alpha_1$, etc.

Collecting these results, we have

$$y_\theta + y_{-\theta} = 2 B_1 \cos \theta + \dots \dots + 2 B_5 \cos 5\theta$$

and

$$y_\theta - y_{-\theta} = 2 A_1 \sin \theta + \dots \dots + 2 A_5 \sin 5\theta$$

If ordinates are taken at intervals of 30° , commencing from $\theta = 0^\circ$, then twelve ordinates are obtained in one complete cycle. These can be arranged in pairs as follows:—

Sums			Differences		
y_0	$+ y_0$	$= 2 y_0$	y_0	$- y_0$	$= 0$
y_{30}	$+ y_{-30}$	$= y_{30} + y_{330}$	y_{30}	$- y_{-30}$	$= y_{30} - y_{330}$
y_{60}	$+ y_{-60}$	$= y_{60} + y_{300}$	y_{60}	$- y_{-60}$	$= y_{60} - y_{300}$
y_{90}	$+ y_{-90}$	$= y_{90} + y_{270}$	y_{90}	$- y_{-90}$	$= y_{90} - y_{270}$
y_{120}	$+ y_{-120}$	$= y_{120} + y_{240}$	y_{120}	$- y_{-120}$	$= y_{120} - y_{240}$
y_{150}	$+ y_{-150}$	$= y_{150} + y_{210}$	y_{150}	$- y_{-150}$	$= y_{150} - y_{210}$
y_{180}	$+ y_{-180}$	$= 2 y_{180}$	y_{180}	$- y_{-180}$	$= 0$

Substituting the known values (0° , 30° , 60° , etc.) for $\cos \theta$ in the sums terms, and for $\sin \theta$ in the differences terms, we get:

$$\begin{aligned} y_0 + y_0 &= 2 B_1 + 2 B_2 + 2 B_3 + 2 B_4 + 2 B_5 \\ y_{30} + y_{330} &= \sqrt{3} B_1 + B_2 - B_4 - \sqrt{3} B_5 \\ y_{60} + y_{300} &= B_1 - B_2 - 2 B_3 - B_4 + B_5 \\ y_{90} + y_{270} &= -2 B_2 + 2 B_4 \\ y_{120} + y_{240} &= -B_1 - B_2 + 2 B_3 - B_4 - B_5 \\ y_{150} + y_{210} &= -\sqrt{3} B_1 + B_2 - B_4 + \sqrt{3} B_5 \\ y_{180} + y_{180} &= -2 B_1 + 2 B_2 - 2 B_3 + 2 B_4 - 2 B_5 \\ \text{and } y_0 - y_0 &= 0 \\ y_{30} - y_{330} &= A_1 + \sqrt{3} A_2 + 2 A_3 + \sqrt{3} A_4 + A_5 \\ y_{60} - y_{300} &= \sqrt{3} A_1 + \sqrt{3} A_2 - \sqrt{3} A_4 - \sqrt{3} A_5 \\ y_{90} - y_{270} &= 2 A_1 - 2 A_3 + 2 A_5 \\ y_{120} - y_{240} &= \sqrt{3} A_1 - \sqrt{3} A_2 + \sqrt{3} A_4 - \sqrt{3} A_5 \\ y_{150} - y_{210} &= A_1 - \sqrt{3} A_2 + 2 A_3 - \sqrt{3} A_4 + A_5 \\ y_{180} - y_{180} &= 0. \end{aligned}$$

There are five unknowns in each group of equations, and sufficient equations to enable all ten unknowns to be evaluated in general terms, so that the various constants, A_1 , B_1 , etc., can be evaluated in terms of the sums and differences of known pairs of ordinates, and finally in terms of the individual ordinates themselves.

The initial labour in solving these numerous equations is considerable, but this having been accomplished in general terms, the results can be

utilised for the analysis of any periodic wave containing harmonics, odd or even, not higher than the fifth.

Each ordinate must be multiplied by a known constant (taking care to observe whether it is positive or negative), and the resulting products added together.

The general solutions, giving the various multipliers obtained by solving the simultaneous equations enumerated above, are as follows:—

$$A_1 = \frac{1}{6}(y_{90} - y_{270}) + \frac{1}{12}(y_{30} + y_{150} - y_{210} - y_{330}) + \frac{1}{4\sqrt{3}}(y_{60} + y_{120} - y_{240} - y_{300})$$

$$A_2 = \frac{1}{4\sqrt{3}}(y_{30} + y_{60} - y_{120} - y_{150} + y_{210} + y_{240} - y_{300} - y_{330})$$

$$A_3 = \frac{1}{6}(y_{30} - y_{90} + y_{150} - y_{210} + y_{270} - y_{330})$$

$$A_4 = \frac{1}{4\sqrt{3}}(y_{30} - y_{60} + y_{120} - y_{150} + y_{210} - y_{240} + y_{300} - y_{330})$$

$$A_5 = \frac{1}{6}(y_{90} - y_{270}) + \frac{1}{12}(y_{30} + y_{150} - y_{210} - y_{330}) - \frac{1}{4\sqrt{3}}(y_{60} + y_{120} - y_{240} - y_{300})$$

$$B_1 = \frac{1}{6}(y_0 - y_{180}) + \frac{1}{12}(y_{60} - y_{120} - y_{240} + y_{300}) + \frac{1}{4\sqrt{3}}(y_{30} - y_{150} - y_{210} + y_{330})$$

$$B_2 = \frac{1}{4}(y_0 + y_{180}) - \frac{1}{6}(y_{30} + y_{150} + y_{210} + y_{330}) - \frac{5}{12}(y_{90} + y_{270})$$

$$B_3 = \frac{1}{6}(y_0 - y_{60} + y_{120} - y_{180} + y_{240} - y_{300})$$

$$B_4 = \frac{1}{4}(y_0 + y_{90} + y_{180} + y_{270})$$

$$B_5 = \frac{1}{6}(y_0 - y_{180}) + \frac{1}{12}(y_{60} - y_{120} - y_{240} + y_{300}) - \frac{1}{4\sqrt{3}}(y_{30} - y_{150} - y_{210} + y_{330})$$

The sums of the resulting products of ordinate and multiplier give the constants A_1, B_1 , etc. (It should be noted that not only may the multiplier be positive or negative, but also that the ordinate itself may be positive or negative.)

For the actual analysis of a wave, the multipliers may be conveniently arranged in the form of a table shown on page 18.

The various ordinates graphed from the wave to be analysed are entered in the second column, in both the "A" and "B" tables, marking those ordinates which come below the X axis as negative. These various ordinates are now multiplied by the appropriate constants and the resulting products entered in the fourth column, care again being exercised to insert correctly any negative products. This is then repeated for the A_2, A_3, A_4 and A_5 values. Each column of products is then added up, and the total inserted at the bottom. The resulting totals give the five "A" values required.

The whole procedure is now repeated for the "B" values, the resulting totals here giving the five "B" values required.

The amplitudes of the fundamental and the first four harmonics are now given by

$$Y_1 = \sqrt{A_1^2 + B_1^2}$$

$$Y_2 = \sqrt{A_2^2 + B_2^2}$$

$$Y_3 = \sqrt{A_3^2 + B_3^2}$$

$$Y_4 = \sqrt{A_4^2 + B_4^2}$$

$$\text{and } Y_5 = \sqrt{A_5^2 + B_5^2}$$

As already explained, the phase angles of the various components are given by

$$a_1 = \tan^{-1} \frac{B_1}{A_1}, \text{ etc.}$$

In certain cases it may be required to ascertain the amplitude of one particular harmonic, in which case the appropriate columns only need be filled up in the table. Again, in certain other cases, either the "A" or the "B" values are all equal to zero, which further simplifies the evaluation.

As an example, the synthesized wave shown in Fig. 1 will be analysed.

This wave obviously contains a very considerable D.C. component, so that this must first be eliminated. This is done by averaging a selected number of ordinates over a complete period, thus obtaining the average value of the wave. On examination, the average

value, and therefore the D.C. component, is found to be 80 units. The average value of the remainder of the wave is now equal to zero, this being composed of A.C. components only, and the analysis of these resultant A.C. components can now be undertaken. For this purpose, ordinates are now measured from the false zero line set 80 units above the original X axis. Using the tables already explained, the selected ordinates from the graph are entered in the second column, and the analysis of the "A" values is carried out as shown on page 17.

The amplitudes of the fundamental and the various harmonics are:

$$Y_1 = \sqrt{86.36^2 + 49.77^2} = 99.7$$

$$Y_2 = \sqrt{24.9^2 + 43.67^2} = 50.3$$

$$Y_3 = \sqrt{(-12.5)^2 + 21.67^2} = 25.0$$

$$Y_4 = \sqrt{17.2^2 + (-10.00)^2} = 19.9$$

$$Y_5 = \sqrt{(-8.34)^2 + (-4.93)^2} = 9.7$$

The respective phase angles are:

$$a_1 = \tan^{-1} \frac{49.77}{86.36} = 29.9^\circ$$

$$a_2 = \tan^{-1} \frac{43.67}{24.9} = 60.3^\circ$$

$$a_3 = \tan^{-1} \frac{21.67}{-12.5} = 120.0^\circ$$

$$a_4 = \tan^{-1} \frac{-10.0}{17.2} = -30.2^\circ$$

$$a_5 = \tan^{-1} \frac{-4.93}{-8.34} = -149.4^\circ$$

The components of the synthesized wave and the results of its subsequent analysis are shown in the following tables:—

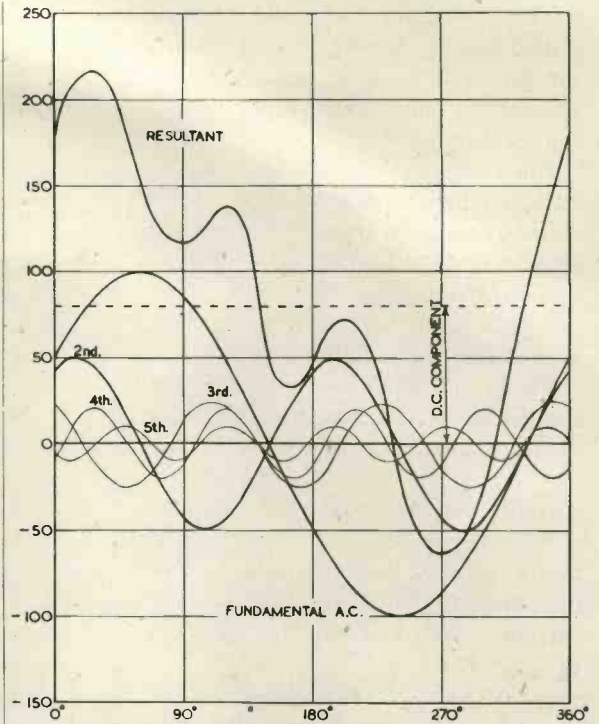

Fig. 1. Synthesized curve and components.

COMPONENT	SYNTHESIZED WAVE	ANALYSED WAVE
Fundamental	100 sin ($\omega t + 30^\circ$)	99.7 sin ($\omega t + 29.9^\circ$)
Second Harmonic	50 sin ($2 \omega t + 60^\circ$)	50.3 sin ($2 \omega t + 60.3^\circ$)
Third	25 sin ($3 \omega t + 120^\circ$)	25.0 sin ($3 \omega t + 120^\circ$)
Fourth	20 sin ($4 \omega t - 30^\circ$)	19.9 sin ($4 \omega t - 30.2^\circ$)
Fifth	10 sin ($5 \omega t - 150^\circ$)	9.7 sin ($5 \omega t - 149.4^\circ$)

COMPONENT	ERROR	
	Amplitude, per cent.	Phase Angle
Fundamental	0.3% low	0.1° lag
Second Harmonic	0.6% high	0.3° lead
Third	correct	correct
Fourth	0.5% low	0.2° lag
Fifth	3% low	0.6° lead

The accuracy of the results obtainable, both as regards magnitude and phase angle, are thus seen to be quite satisfactory for all practical purposes.

Another example of interest to radio engineers, is that of the ideal rectifier. Such a rectifier is supposed to pass one-half of a wave of A.C. without reduction or distortion, whilst not permitting any current at all to flow during the remaining half-cycle.

The conditions are illustrated in Fig. 2, the current rising to a maximum of I_m . The average value of the

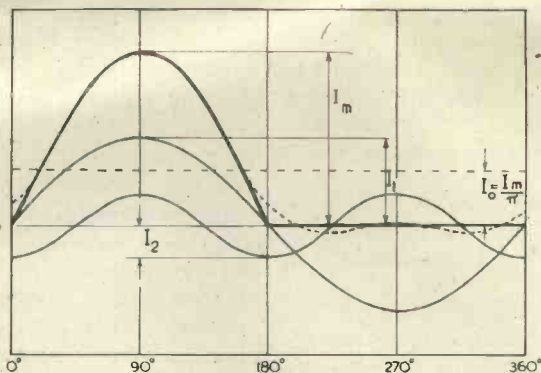

Fig. 2. Wave form of half wave rectifier which is analysed in the table underneath.

current over a half-cycle is $\frac{2}{\pi} I_m$, but

taking into consideration the second (inoperative) half-cycle, the average current over a complete cycle is $\frac{I_m}{\pi} = 0.318 I_m$. This average value

is therefore the value of the D.C. component ($= I_0$).

After this D.C. component has been subtracted from the original wave (half of which lies on the X axis); the remaining current can, to a rough degree of approximation, be represented by a fundamental and a second harmonic. Assuming, for the moment, that no higher harmonics are present, the following relations exist.

At $\omega t = 90^\circ$, the current is a maximum, and

$$I_m = I_0 + I_1 + I_2$$

$$= \frac{I_m}{\pi} + I_1 + I_2 \quad \dots (1)$$

At $\omega t = 270^\circ$, the current is zero, and

$$0 = \frac{I_m}{\pi} - I_1 + I_2 \quad \dots (2)$$

Subtracting (2) from (1), we get

$$I_m = 2I_1, \text{ and } I_1 = \frac{I_m}{2}$$

Also, substituting in (2) we get

$$0 = \frac{I_m}{\pi} - \frac{I_m}{2} + I_2$$

$$\text{and } I_2 = \frac{I_m}{2} - \frac{I_m}{\pi} = \left(\frac{1}{2} - \frac{1}{\pi} \right) I_m = 0.182 I_m.$$

The resultant of the D.C., the fundamental and the second harmonic A.C. is indicated by the dotted curve, showing the closeness of the approximation to the original.

The wave represented by a sine wave with its second half-cycle suppressed will now be analysed. In the case of certain theoretical wave forms, it may be deemed expedient to use the formulae for the values A_1, B_1 , etc., rather than the tables, and the analysis will now be carried out by using the formulae directly.

Assuming a maximum value of 100 units for the original half-sine wave, the value of the D.C. becomes $\frac{100}{\pi} = 31.8$, and the ordinates of the

subtracted, assume the following values:—

Ordinate	Instantaneous value
0°	$100 - \frac{100}{\pi} = 68.2$
30°	$50 - \frac{100}{\pi} = 18.2$
60°	$\frac{\sqrt{3}}{2} \times 100 - \frac{100}{\pi} = 54.8$
90°	$100 - \frac{100}{\pi} = 68.2$
	etc.

resultant A.C., after the D.C. has been

The equations for the various constants are now the following:—

$$A_1 = \frac{1}{6} \left(100 - \frac{100}{\pi} + \frac{100}{\pi} \right) + \frac{1}{12} \left(50 - \frac{100}{\pi} + 50 - \frac{100}{\pi} + \frac{100}{\pi} + \frac{100}{\pi} \right) + \frac{1}{4\sqrt{3}} \left(\frac{\sqrt{3}}{2} \times 100 - \frac{100}{\pi} + \frac{\sqrt{3}}{2} \times 100 - \frac{100}{\pi} + \frac{100}{\pi} + \frac{100}{\pi} \right) = 50$$

$$B_1 = \frac{1}{6} \left(-\frac{100}{\pi} + \frac{100}{\pi} \right) + \frac{1}{12} \left(\frac{\sqrt{3}}{2} \times 100 - \frac{100}{\pi} - \frac{\sqrt{3}}{2} \times 100 + \frac{100}{\pi} + \frac{100}{\pi} - \frac{100}{\pi} \right) + \frac{1}{4\sqrt{3}} \left(50 - \frac{100}{\pi} - 50 + \frac{100}{\pi} + \frac{100}{\pi} - \frac{100}{\pi} \right) = 0$$

$$A_2 = \frac{1}{4\sqrt{3}} \left(50 - \frac{100}{\pi} + \frac{\sqrt{3}}{2} \times 100 - \frac{100}{\pi} - \frac{\sqrt{3}}{2} \times 100 + \frac{100}{\pi} - 50 + \frac{100}{\pi} - \frac{100}{\pi} + \frac{100}{\pi} + \frac{100}{\pi} \right) = 0$$

$$B_2 = \frac{1}{4} \left(-\frac{100}{\pi} - \frac{100}{\pi} \right) - \frac{1}{6} \left(50 - \frac{100}{\pi} + 50 - \frac{100}{\pi} - \frac{100}{\pi} - \frac{100}{\pi} \right) - \frac{5}{12} \left(100 - \frac{100}{\pi} - \frac{100}{\pi} \right) = -26.51$$

$$A_3 = \frac{1}{6} \left(50 - \frac{100}{\pi} - 100 + \frac{100}{\pi} + 50 - \frac{100}{\pi} + \frac{100}{\pi} - \frac{100}{\pi} + \frac{100}{\pi} \right) = 0$$

$$B_3 = \frac{1}{6} \left(\frac{100}{\pi} - \frac{\sqrt{3}}{2} \times 100 + \frac{100}{\pi} + \frac{\sqrt{3}}{2} \times 100 - \frac{100}{\pi} + \frac{100}{\pi} - \frac{100}{\pi} + \frac{100}{\pi} \right) = 0$$

$$A_4 = \frac{1}{4\sqrt{3}} \left(50 - \frac{100}{\pi} - \frac{\sqrt{3}}{2} \times 100 + \frac{100}{\pi} + \frac{\sqrt{3}}{2} \times 100 - \frac{100}{\pi} - 50 + \frac{100}{\pi} - \frac{100}{\pi} + \frac{100}{\pi} + \frac{100}{\pi} \right) = 0$$

$$B_4 = \frac{1}{4} \left(\frac{100}{\pi} + 100 - \frac{100}{\pi} - \frac{100}{\pi} - \frac{100}{\pi} \right) = -6.82$$

$$A_5 = \frac{1}{6} \left(100 - \frac{100}{\pi} + \frac{100}{\pi} \right) + \frac{1}{12} \left(50 - \frac{100}{\pi} + 50 - \frac{100}{\pi} + \frac{100}{\pi} + \frac{100}{\pi} \right) - \frac{1}{4\sqrt{3}} \left(\frac{\sqrt{3}}{2} \times 100 - \frac{100}{\pi} + \frac{\sqrt{3}}{2} \times 100 - \frac{100}{\pi} + \frac{100}{\pi} + \frac{100}{\pi} \right) = 0$$

$$B_5 = \frac{1}{6} \left(-\frac{100}{\pi} + \frac{100}{\pi} \right) + \frac{1}{12} \left(\frac{\sqrt{3}}{2} \times 100 - \frac{100}{\pi} - \frac{\sqrt{3}}{2} \times 100 + \frac{100}{\pi} + \frac{100}{\pi} - \frac{100}{\pi} \right) - \frac{1}{4\sqrt{3}} \left(50 - \frac{100}{\pi} - 50 + \frac{100}{\pi} + \frac{100}{\pi} - \frac{100}{\pi} \right) = 0$$

The fact that such a number of the constants are equal to zero explains why it is a saving in time to use the formulae directly, instead of the tables.

Using the formulae $I_1 = \sqrt{A_1^2 + B_1^2}$, etc., the amplitudes of the various components are found to be:—

$$I_0 = \frac{100}{\pi} = 31.82$$

$$I_1 = \frac{350}{6} + \frac{100}{\pi} = 50.00$$

$$I_2 = -\frac{350}{6} + \frac{100}{\pi} = -26.51$$

$$I_3 = 0 = 0$$

$$I_4 = 25 - \frac{100}{\pi} = 6.82$$

$$\frac{I_5}{I_m} = 0 = 0$$

The fourth harmonic opposes the second at the point of maximum current. The difference of the amplitudes of these two harmonics is $26.51 - 6.82 = 19.69$ against the 18.18 in the original approximation. The fundamental A.C. is, however, seen to have exactly half the amplitude of the original half sine wave.

When a number of waves have to be analysed, a considerable saving in time will be gained by the construction of a template for the tables of the "A" and "B" constants. This can be done by placing a sheet of drawing paper or cardboard over the table and cutting slots for the ordinates column and the five columns of products, leaving spaces at the bottom for the totals. The values of the various angles can then be entered in the first column, and the constants in the four columns of multipliers can be entered permanently in their respective columns. Two templates will be required, one for the "A" values and the other for the "B" values. To use them, they are placed over a blank sheet of paper on which the particular ordinates and products are marked, leaving the template to be used again on other analyses.

In a very large number of cases, both for electrical power engineers and radio engineers alike, the analysis of a wave up to the first two odd harmonics and the first two even harmonics is all that is necessary, and for such purposes any method which carries the analysis up to this stage fulfils the requirements of practice. It is claimed that the present method does this without any unnecessary labour of computation, although if any higher harmonics are present in any magnitude, the accuracy of the results will be affected.

Angle	Ordinate	A ₁		A ₂		A ₃		A ₄		A ₅	
		Multiplr.	Prdct.	Multiplr.	Prdct.	Multiplr.	Prdct.	Multiplr.	Prdct.	Multiplr.	Prdct.
0°	100	-	-	-	-	-	-	-	-	-	-
30°	137	.083	11.42	.144	See (a)	.167	See (b)	.144	See (c)	.083	11.42
60°	73	.144	10.51	.144	below	-	below	-.144	below	-.144	-10.51
90°	37	.167	6.17	-	-	-.167	-	-	-	.167	6.17
120°	58	.144	8.35	-.144	-	-	-	.144	-	-.144	-8.35
150°	-31	.083	-2.58	-.144	-	.167	-	-.144	-	.083	-2.58
180°	-33	-	-	-	-	-	-	-	-	-	-
210°	-11	-.083	0.92	.144	-	-.167	-	.144	-	-.083	0.92
240°	-93	-.144	13.39	.144	-	-	-	-.144	-	.144	-13.39
270°	-144	-.167	24.0	-	-	.167	-	-	-	-.167	24.0
300°	-105	-.144	15.1	-.144	-	-	-	.144	-	.144	-15.1
330°	11	-.083	-0.92	-.144	-	-.167	-	-.144	-	-.083	-0.92
TOTALS		A ₁ = 86.36		A ₂ = 24.9		A ₃ = -12.5		A ₄ = 17.2		A ₅ = -8.34	

.083 = 1/12 .144 = 1/4√3 .167 = 1/6

Angle	Ordinate	B ₁		B ₂		B ₃		B ₄		B ₅	
		Multiplr.	Prdct.	Multiplr.	Prdct.	Multiplr.	Prdct.	Multiplr.	Prdct.	Multiplr.	Prdct.
0°	100	.167	16.67	.25	25	.167	-	.25	-	.167	16.67
30°	137	.144	19.73	-.167	-22.83	-	See (d)	-	See (e)	-.144	-19.73
60°	73	.083	6.08	-	-	-.167	below	-	below	.083	6.08
90°	37	-	-	-.417	-15.42	-	-	.25	-	-	-
120°	58	-.083	-4.83	-	-	.167	-	-	-	-.083	-4.83
150°	-31	-.144	-4.46	-.167	5.17	-	-	-	-	.144	-4.46
180°	-33	-.167	5.50	.25	-8.25	-.167	-	.25	-	-.167	5.50
210°	-11	-.144	1.58	-.167	1.83	-	-	-	-	.144	-1.58
240°	-93	-.083	7.75	-	-	.167	-	-	-	-.083	7.75
270°	-144	-	-	-.417	60.0	-	-	.25	-	-	-
300°	-105	.083	-8.75	-	-	-.167	-	-	-	.083	-8.75
330°	11	.144	1.58	-.167	-1.83	-	-	-	-	-.144	-1.58
TOTALS		B ₁ = 49.77		B ₂ = 43.67		B ₃ = 21.67		B ₄ = -10.0		B ₅ = -4.93	

.25 = 1/4 .417 = 5/12

- (a) Since the A₂ multipliers are all (+ or -) $\frac{1}{4\sqrt{3}}$, it is convenient to add or subtract the ordinates, multiplying the resultant by $\frac{1}{4\sqrt{3}}$, instead of multiplying each ordinate separately.
- (b) The A₃ multipliers are all (+ or -) $\frac{1}{6}$, so that it is convenient to adopt the same procedure as for the A₂ multipliers.
- (c) The treatment of the A₄ multipliers can be simplified exactly as in the case of the A₂ ones.
- (d) The B₃ multipliers are all (+ or -) $\frac{1}{6}$, so that it is convenient to add or subtract the ordinates, multiplying the resultant by $\frac{1}{6}$.
- (e) The B₄ multipliers are all $\frac{1}{4}$, so that the same procedure is also adopted here.

**TABLE OF A AND B VALUES FOR
ANALYSIS UP TO THE FIFTH HARMONIC**

Angle	Ordinate	A ₁		A ₂		A ₃		A ₄		A ₅	
		Multplr.	Prdct.	Multplr.	Prdct.	Multplr.	Prdct.	Multplr.	Prdct.	Multplr.	Prdct.
0°		-	-	-	-	-	-	-	-	-	-
30°		.083		.144		.167		.144		.083	
60°		.144		.144		-		-.144		-.144	
90°		.167		-		-.167		-		.167	
120°		.144		-.144		-		.144		-.144	
150°		.083		-.144		.167		-.144		.083	
180°		-		-		-		-		-	
210°		-.083		.144		-.167		.144		-.083	
240°		-.144		.144		-		-.144		.144	
270°		-.167		-		.167		-		-.167	
300°		-.144		-.144		-		.144		.144	
330°		-.083		-.144		-.167		-.144		-.083	
TOTALS		A ₁ =		A ₂ =		A ₃ =		A ₄ =		A ₅ =	

$$\cdot 083 = 1/12$$

$$\cdot 144 = 1/4\sqrt{3}$$

$$\cdot 167 = 1/6$$

Angle	Ordinate	B ₁		B ₂		B ₃		B ₄		B ₅	
		Multplr.	Prdct.	Multplr.	Prdct.	Multplr.	Prdct.	Multplr.	Prdct.	Multplr.	Prdct.
0°		.167		.25		.167		.25		.167	
30°		.144		-.167		-		-		-.144	
60°		.083		-		-.167		-		.083	
90°		-		-.417		-		.25		-	
120°		-.083		-		.167		-		-.083	
150°		-.144		-.167		-		-		.144	
180°		-.167		.25		-.167		.25		-.167	
210°		-.144		-.167		-		-		.144	
240°		-.083		-		.167		-		-.083	
270°		-		-.417		-		.25		-	
300°		.083		-		-.167		-		.083	
330°		.144		-.167		-		-		-.144	
TOTALS		B ₁ =		B ₂ =		B ₃ =		B ₄ =		B ₅ =	

$$\cdot 25 = 1/4$$

$$\cdot 417 = 5/12$$

Television Waveforms

By C. E. LOCKHART

An analysis of saw-tooth and rectangular waveforms encountered in Television and Cathode Ray Tube practice.

EVERY engineer who has had practical experience of television will be familiar with the difficulties of providing distortionless amplification for the rectangular, triangular and other waveforms constantly encountered. These waveforms consist of a very large number of component voltages harmonically related and suitably phased, and it is the purpose of this article to illustrate both the mathematical and graphical relations governing these components, for some of the more frequently used waveforms. With an input signal thus analysed it is possible to obtain the resultant wave form after the signal has passed through a channel of known amplitude and phase distortion.

Any waveform that repeats itself at regular intervals can be analysed in the form of a Fourier Series. In the most general case the waveform may be expressed as a summation of an infinite number of harmonically related sine and cosine components plus a D.C. component representing the mean level. Thus a function $f(\omega t)$ representing a given waveform can be expressed by

$$f(\omega t) = A_0 + A_1 \sin \omega t + A_2 \sin 2 \omega t + A_3 \sin 3 \omega t + \dots + A_n \sin n \omega t + B_1 \cos \omega t + B_2 \cos 2 \omega t + B_3 \cos 3 \omega t + \dots + B_n \cos n \omega t \quad (1)$$

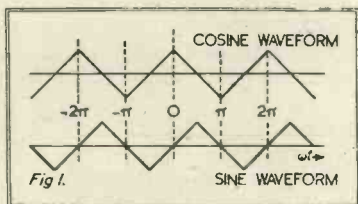

The amplitude of any of the component frequencies $A_0, A_1, A_2, \dots, B_1, B_2, \dots$ may be either positive, negative or zero. Also, either all the sine or cosine terms may be absent. If all the sine terms are absent the waveform is symmetrical about the ordinate $\omega t = 0$ and multiples of 2π , while if all the cosine terms are absent the waveform to the right of the $\omega t = 0$ ordinate will be the reverse of that on the left. (See Fig. 1). The presence of both sine and cosine terms in a given waveform implies that the harmonic components have not only different amplitudes, but different relative initial phase angles as well. This fact is obvious if we consider any given harmonic component, say of frequency $n\omega$, then the resultant component voltage "e" of this frequency in the waveform is:

$$e = E a_n \sin n \omega t + E b_n \cos n \omega t \quad (2)$$

$$= \sqrt{(E a_n)^2 + (E b_n)^2} \sin(n \omega t + \phi_n) \quad (3)$$

$$\text{where } \phi_n = \tan^{-1} E b_n / E a_n \quad (4)$$

The values of the amplitudes of A_n, B_n , and A_0 in equation (1) are given by:

$$A_n = \frac{1}{\pi} \int_0^{2\pi} f(\omega t) \sin n \omega t d(\omega t) \quad (5)$$

$$\text{and } B_n = \frac{1}{\pi} \int_0^{2\pi} f(\omega t) \cos n \omega t d(\omega t) \quad (6)$$

$$A_0 = \frac{1}{2\pi} \int_0^{2\pi} f(\omega t) d(\omega t) \quad (7)$$

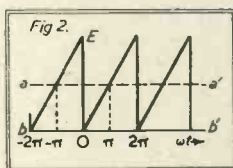

and (7) will be illustrated by simple examples. (a) The equation for the sawtooth wave for the interval $\omega t = 0$ to $\omega t = 2\pi$ is $f(\omega t) = (E/2\pi)\omega t$ (Fig. 2) (8)

$$\text{Therefore } A_0 = \frac{1}{2\pi} \int_0^{2\pi} \frac{E}{2\pi} \omega t d \omega t$$

$$= \frac{E}{4\pi^2} \left[\frac{\omega^2 t^2}{2} \right]_0^{2\pi} = \frac{E}{2} \quad (9)$$

$$\text{and } A_n = \frac{1}{\pi} \int_0^{2\pi} \frac{E}{2\pi} \omega t \sin n(\omega t) d(\omega t)$$

$$= \frac{E}{2\pi^2} \left[\frac{\omega t}{n} \cos n(\omega t) + \frac{1}{n^2} \sin n(\omega t) \right]_0^{2\pi}$$

$$= -\frac{E}{n\pi} \dots \dots \dots (10)$$

$$\text{also } B_n = \frac{1}{\pi} \int_0^{2\pi} \frac{E}{2\pi} (\omega t) \cos n(\omega t) d(\omega t)$$

$$= \frac{E}{2\pi^2} \left[\frac{\omega t}{n} \sin n(\omega t) + \frac{1}{n^2} \cos n(\omega t) \right]_0^{2\pi}$$

$$= 0 \dots \dots \dots (11)$$

The Fourier Series for the sawtooth waveform of Fig. 2 is therefore

$$f(\omega t) = \frac{E}{\pi} \left\{ \frac{\pi}{2} - \sin \omega t - \frac{\sin 2 \omega t}{3} \right.$$

$$\left. - \frac{\sin 3 \omega t}{3} \dots \dots \frac{\sin n \omega t}{n} \right\} \dots (12)$$

$$= \frac{E}{\pi} \left\{ \frac{\pi}{2} - \sum_{n=1}^{\infty} \frac{\sin n(\omega t)}{n} \right\} \dots (13)$$

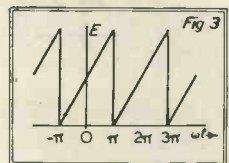

(b) In a similar way we can treat the waveform of Fig. 3 and use the limits of integration of $-\pi$ to $+\pi$. Alternatively we can use

the answer obtained in example a and change the origin by replacing ωt by $(\omega t + \pi)$. Then

$$f(\omega t) = \frac{E}{\pi} \left\{ \frac{\pi}{2} - \sum_{n=1}^{\infty} \frac{\sin n(\omega t + \pi)}{n} \right\} \quad (14)$$

$$= \frac{E}{\pi} \left\{ \frac{\pi}{2} - \sum_{n=1}^{\infty} \frac{\sin n(\omega t) \cos n\pi}{n} \right\} \quad (15)$$

$$= \frac{E}{\pi} \left\{ \frac{\pi}{2} + \sum_{n=1}^{\infty} \frac{(-1)^{n+1} \sin n(\omega t)}{n} \right\} \quad (16)$$

$$= \frac{E}{\pi} \left\{ \frac{\pi}{2} + \sin \omega t - \frac{\sin 2 \omega t}{2} + \frac{\sin 3 \omega t}{3} - \dots \dots \dots \right\} \quad (17)$$

(c.) If in example (a) we remove the D.C. component by moving the axis of Fig. 2 from aa' to bb' , then $f(\omega t) =$

$$\frac{E}{2} - \frac{E}{2\pi} (\omega t) \text{ between } \omega t = 0 \text{ and } \omega t = 2\pi \text{ and } f(\omega t) = E - \frac{E}{2\pi} (\omega t) \text{ between } \omega t = 0 \text{ and } \omega t = -2\pi.$$

A_0 is now given by

$$A_0 = -\frac{1}{2\pi} \int_0^{-2\pi} \frac{E}{2} d(\omega t)$$

$$+ \frac{1}{2\pi} \int_0^{2\pi} \frac{E}{2\pi} (\omega t) d \omega t$$

$$= -\frac{E}{2} + \frac{E}{2} = 0 \dots \dots \dots (18)$$

The values of A_n and B_n remain unchanged.

For this simple case this result could, of course, have been obtained by inspection.

Having analysed the idealised case of a sawtooth with zero fly-back time, it is appropriate to next consider the idealised case of the rectangular pulses commonly met in television. We will again start with the condition of infinitely steep sides for the pulse. While this problem can be treated as before by the direct calculation of the

coefficients A_0 , A_n and B_n we will for the benefit of the readers not too proficient in calculus employ an alternative method using the expressions already obtained together with simple trigonometrical relations.

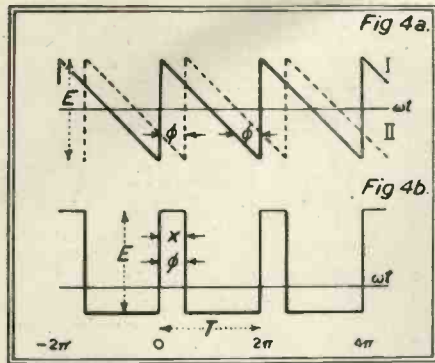

Rectangular Wave (Infinite Slope).

In Fig. 4a are shown two saw-tooth waves with the axis positioned to give zero D.C. component.

Waveform I is the negative of that shown in Fig. 2 (apart from the component) and is therefore represented by (see No. 2. Table I).

$$f(\omega t)_I = \frac{E}{\pi} \sum_{n=1}^{\infty} \frac{\sin n(\omega t)}{n} \quad (19)$$

Waveform II is similar to I but displaced by an angle ϕ so that

$$f(\omega t)_{II} = \frac{E}{\pi} \sum_{n=1}^{\infty} \frac{\sin n(\omega t - \phi)}{n} \quad (20)$$

Fig. 4b shows graphically the result of subtracting II from I which is seen to produce the required rectangular wave. If we call the saw-tooth period time T and the pulse width time x , then the ratio of pulse to period is given by x/T or $\phi/2\pi$, and can be varied at will by a suitable choice of ϕ .

To obtain the equation for Fig. 4b we subtract (20) from (19).

$$f(\omega t)_{I-II} = \frac{E}{\pi} \sum_{n=1}^{\infty} \frac{1}{n} \left\{ \sin n(\omega t) - \sin n(\omega t - \phi) \right\} \quad (21)$$

$$= \frac{2E}{\pi} \sum_{n=1}^{\infty} \frac{1}{n} \left\{ \sin \frac{n\phi}{2} \cos n \left(\omega t - \frac{\phi}{2} \right) \right\} \quad (22)$$

$$\text{or} = \frac{2E}{\pi} \sum_{n=1}^{\infty} \frac{1}{n} \left(\frac{\sin \left(\frac{n x \pi}{T} \right)}{\cos n \left(\omega t - \frac{2 \pi x}{T} \right)} \right) \quad (23)$$

(See proof in Appendix I.)

To shift the origin to the centre of the pulse we add an angle $\phi/2$ to ωt , thus replacing ωt by $(\omega t + \phi/2)$ or ωt by $(\omega t + \frac{2\pi x}{T})$ and equations (22) and (23) become

$$\frac{2E}{\pi} \sum_{n=1}^{\infty} \frac{1}{n} \sin \frac{n\phi}{2} \cos n \omega t \quad (22 a)$$

$$\frac{2E}{\pi} \sum_{n=1}^{\infty} \frac{1}{n} \sin \frac{n x \pi}{T} \cos n \omega t \quad (23 a)$$

where (22a) and (23a) are alternative forms for the summation of $B_n \cos n\omega t$ of equation (1) the A_n terms and A_0 term being zero.

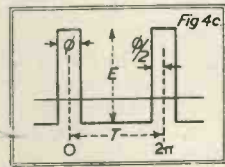

If, however, we want to introduce the D.C. component then

$$A_0 = \frac{\phi}{2\pi} E = \frac{x}{T} E \quad (24)$$

The equations for the special case of square waves, i.e., $\phi = \pi$ in (22) and (22a) will be found in Table I. No. 11 and 12.

So far we have considered idealised waves; in practice a saw-tooth is never obtained with zero fly-back time. For a fly-back time T_R and letting $T_R/T = p$ this case can be treated by the methods described and Von Ardenne has given the relation:

$$f(\omega t) = \frac{E}{n^2 \pi^2 p} \sin n \phi \pi \cos n \pi \sin n(\omega t) \quad (25)$$

$$= (-1)^{n-1} \frac{E}{n^2 \pi^2 p} \sin n \phi \pi \sin n(\omega t) \quad (26)$$

This relation together with the result of the addition of the first ten harmonics for $p = 0.1$ is shown in Fig. 5.

In Fig. 5 and equations (25) and (26) it will be seen that the amplitude decreases with increase in " ϕ ." To keep the amplitude constant at E (see Data Sheet No. 29) the equation (26) must be modified to

$$f(\omega t) = \left\{ (-1)^{n-1} \frac{E}{n^2 \pi^2 p (1-p)} \sin n \phi \pi \times \sin n(\omega t) \right\} \quad (27)$$

A particular case of the finite retrace saw-tooth is the triangular wave when $\phi = \frac{1}{2}$. Series for this are given in Table I by No. 6 and with shift of origin by No. 7.

The effect of increasing the retrace time is to reduce the amplitude of the higher harmonics relative to the fundamental. This is well illustrated for the wave of equation (27) by Data Sheet No. 29 which shows the change in magnitude of the first ten harmonics with values of ϕ from 0 to 1.

An examination of equations (25) and (27) shows that each component harmonic vanishes when $n = 1/\phi$ or multiples of $1/\phi$. Thus if $p = 0.1$ that is a retrace time of 10 per cent. then the tenth, twentieth, thirtieth, etc., harmonics will vanish.

For the waveform given by (25) and (26) (which only differs from (27) in the absolute magnitude of the component waves and not in their relative ratios). Von Ardenne has given (Fig. 6) the frequency spectrum up to the twentieth harmonic for values of $\phi = 0$, $\phi = 0.05$ and $\phi = 0.1$. The rapid decrease of the harmonic components and the vanishing of the tenth and twentieth is well illustrated. For small values of ϕ up

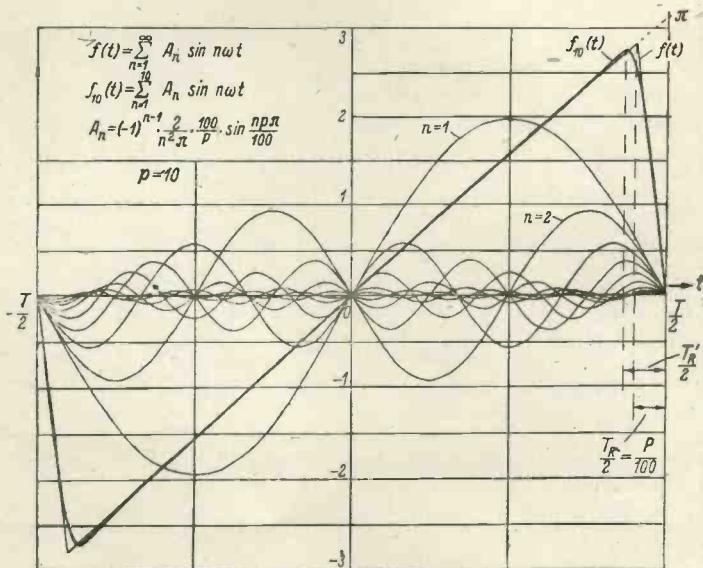

Fig. 5. Harmonics of a saw-tooth waveform (p is in per cent) (- from von Ardenne)

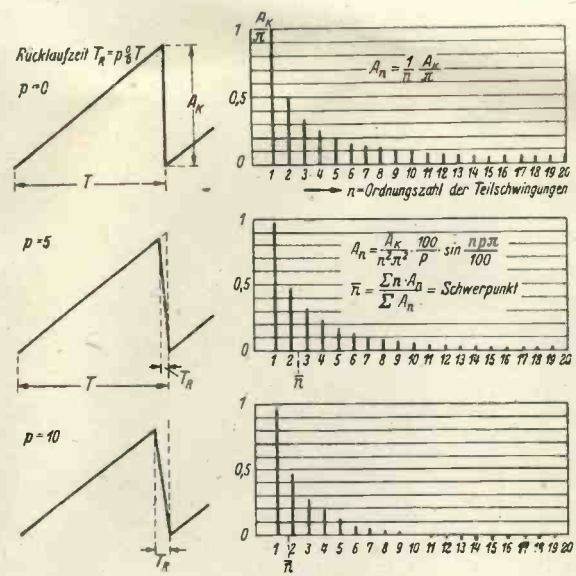
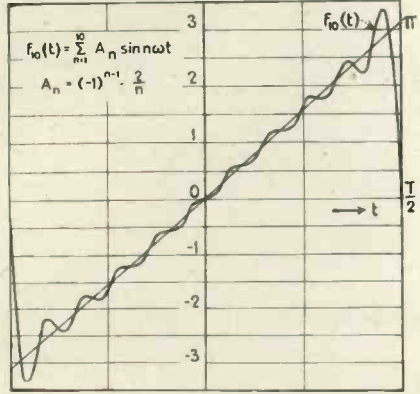

Fig. 6. (above) Frequency spectrum of saw-tooth waves for three values of p .

Fig. 7. (below) Effect of neglecting all components above the 10th. harmonic with zero retrace time. (—both after von Ardenne).



to say 0.1 the effect of neglecting all frequencies above $u = 1/p$ is small. As will be seen from Fig. 5 for $p = 0.1$ this mainly rounds the tip of the wave which slightly reduces its amplitude and slightly increases the retrace time.

The effect of neglecting all components above the tenth for a saw-tooth with zero retrace time $p = 0$ would, however, be considerable and is shown in Fig. 7.

In general, it may be stated that with steep sided waveforms, unless the phase angle is proportional to frequency the effect of phase shift will be far more serious than that of attenuation of the higher component frequencies. Attenuation of the fundamental when large may cause serious distortion.

Just as in the case of the saw-tooth waveform, rectangular pulses encountered in practice are never perfect, the slope of the sides being always finite

and the sharp corners rounded off. While it is only possible to represent an actual waveform by a complicated series, the trapezoidal approximation for the actual pulse as shown by Fig. 8 and No. 13 Table I can be represented by a reasonably simple expression, and the omission of high order harmonics will tend to round off the corners just as is the case of the saw-tooth waveform. Following the method used for the idealised rectangular waveform this pulse may be obtained by the subtraction of two saw-tooth waveforms with finite retrace times and suitably phase displaced, as is shown in Fig. 8. As this waveform has not been treated in text books and provides a very suitable

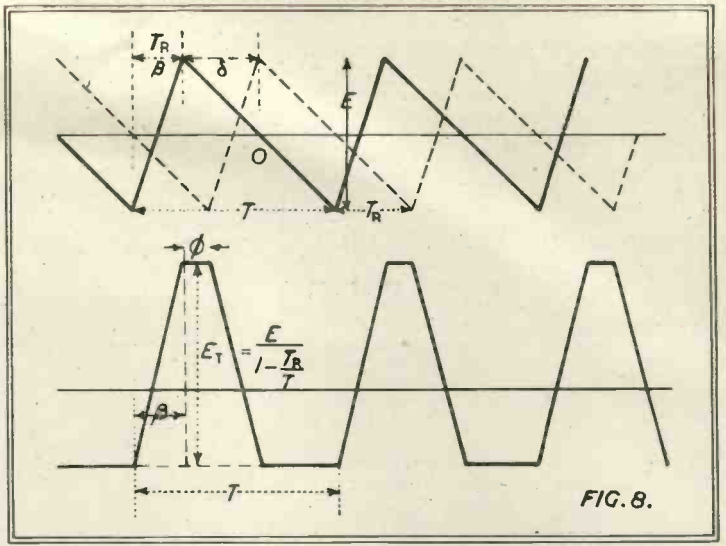

FIG. 8.

generalised example for the method of calculating the coefficients, it is treated in appendix II which should provide a guide for any other waveform the reader may have to tackle.

In a similar way to the saw-tooth and rectangular waveforms the individual harmonic components go through zero when $n = 1/p$ and $n = 1/(p + s)$ or multiples thereof. A special case of the waveform No. 13 is the triangular pulse produced when $s = 0$ and this is given by No. 14 in Table I.

The amplitudes of the component frequencies produced by applying a sinusoidal input to a half wave and full wave linear rectifier are given in Table I by No. 15 and No. 16 respectively.

APPENDIX I.

Proof of equation (22)

Equation 21 is of the form $e = \{ \sin n \theta - \sin n (\theta - \phi) \}$ this is illustrated with unity vectors in Fig. 9 opposite for a given value of n . Expanding $\sin n (\theta - \phi)$ we obtain.

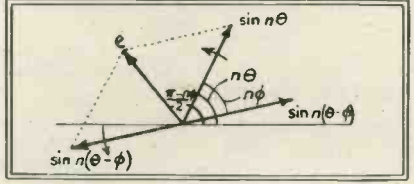

$$e = (1 - \cos n \phi) \sin n \theta + \sin n \phi \cos n \theta$$

$$= \sqrt{(1 - \cos n \phi)^2 + \sin^2 n \phi} \cdot \sin \left[n \theta + \tan^{-1} \left(\frac{\sin n \phi \dots}{1 - \cos n \phi} \right) \right]$$

$$= \sqrt{2 - 2 \cos n \phi} \cdot \sin \left[n \theta + \tan^{-1} \left(\cot \frac{n \phi}{2} \right) \right]$$

$$= 2 \sqrt{\frac{1 - \cos n \phi}{2}} \cdot \sin \left[n \theta + \frac{\pi}{2} - \frac{\phi}{2} \right] = 2 \sin \frac{n \phi}{2} \cos n \left[\theta - \frac{\phi}{2} \right]$$

As if we let $\tan^{-1} \left(\cot \frac{n \phi}{2} \right) = \alpha$ then $\frac{\cos \frac{n \phi}{2}}{\sin \frac{n \phi}{2}} = \frac{\sin \alpha}{\cos \alpha}$

therefore $\cos \frac{n \phi}{2} \cos \alpha - \sin \alpha \sin \frac{n \phi}{2} = 0 = \cos \left(\frac{n \phi}{2} + \alpha \right)$

and $\frac{n \phi}{2} + \alpha = \pm \frac{\pi}{2}$ and $\alpha = \pm \frac{\pi}{2} - \frac{n \phi}{2}$

Calculation of B_n and A_0 for waveform 13 Table I.

The equation of the wave between $\theta = 0$ and $\theta = \phi/2$ is $f(\theta) = E$ and between $\theta = \phi/2$ and $\theta = (\phi/2 + \beta)$ the equation is :

$$f(\theta) = \frac{E}{\beta} \left(\frac{\phi}{2} + \beta - \theta \right)$$

Let $\phi + 2\beta = \gamma$. Then :-

$$B_n = \frac{2}{\pi} \int_0^{\phi/2} (E \cos n\theta) d\theta + \frac{2}{\pi} \int_{\phi/2}^{\gamma/2} \frac{\gamma/2 E}{\gamma - \phi} (\gamma - \theta) \cos n\theta d\theta$$

$$= \frac{2E}{\pi} \left\{ \left[\frac{\sin n\theta}{n} \right]_0^{\phi/2} + \frac{\gamma}{\gamma - \phi} \left[\frac{\sin n\theta}{n} \right]_{\phi/2}^{\gamma/2} \right.$$

$$\left. - \frac{2}{\gamma - \phi} \left[\frac{\theta \sin n\theta}{n} + \frac{\cos n\theta}{n^2} \right]_{\phi/2}^{\gamma/2} \right\}$$

$$= \frac{4E}{n^2 \pi (\gamma - \phi)} \left[\cos \frac{n\phi}{2} - \cos \frac{n\gamma}{2} \right]$$

$$= \frac{2E}{n^2 \pi^2 \beta} \sin n\beta \pi \sin n(\beta + s) \pi$$

and $A_0 = \frac{2E}{2\pi} \int_0^{\phi/2} 1 \cdot d\theta + \frac{2E}{2\pi} \int_{\phi/2}^{\gamma/2} \frac{\gamma/2}{\gamma - \phi} (\gamma - \theta) d\theta$

$$= \frac{E}{2\pi} \left\{ \left[\theta \right]_0^{\phi/2} + \frac{2}{\gamma - \phi} \left[\gamma\theta - \theta^2 \right]_{\phi/2}^{\gamma/2} \right.$$

$$\left. = \frac{E}{2\pi} (\phi + \beta) = E \left[s + \beta \right] \right.$$

DATA SHEETS XXIX—XXXI.

Data Sheet No. 29.

Data Sheet 29 illustrates the variation of the amplitudes of the constituent harmonics of a saw-tooth waveform as the retrace time is varied. Starting with $\beta = 0$ which is a saw-tooth with the fly-back occupying an infinitely short time as illustrated by No. 3 in Table I, the fly-back or retrace time is increased with increase of the value of β up to $\beta = 0.5$. The fly-back as a percentage of the period of the waveform is given by 100β for β between 0 and 0.5. With $\beta = 0.5$ the waveform is triangular and of the shape shown in No. 7 Table I. For value of β between 0.5 and 1 the fly-back time as a percentage of the period is given by $100(1-\beta)$ and when β reaches unity the fly-back time is again zero and the waveform becomes transformed to the shape given by (2) and (8) in Table I.

As would have been expected all the components are now in phase at the instant $\omega t = 0$ and on summation produce

the infinitely steep slope present with a zero retrace time; similarly the finite slope of the retrace portion as β tends towards 0.5 is due to the reduction of the amplitude of the higher harmonics compared with the fundamental, the amplitude of the fundamental increasing to a maximum for $\beta = 0.5$.

On the sheet the amplitude of the individual harmonic components (which are marked by numbers according to their order: $n = 1$ for the fundamental, $n = 2$ for the second harmonic) is expressed as a ratio of the peak-to-peak amplitude E of the saw-tooth which remains constant for all values of β . For any given value of β the amplitudes of the constituent harmonics are read by taking a cross-section through the curves at the ordinate given by β . For the sake of clearness the ninth and tenth harmonic curves have been drawn with a thinner line and not carried through all the values of β .

Data Sheet No. 30.

Data Sheet No. 30 illustrates similar relations for the case of a rectangular pulse with infinitely steep sides. The amplitude of the first ten harmonics is plotted against the factor $s = x/T = \phi/2\pi$ which is the ratio of the pulse width to the period time. With very narrow pulses all the harmonics tend to have an equal amplitude, this equality being achieved for an infinitely thin pulse. As the pulse width is altered, so certain of the harmonics disappear (whenever $n = 1/s$ or a multiple thereof) until for a pulse occupying half a period ($s = x/T = 0.5$) all the even harmonics vanish. At $s = 0.3$ all the odd harmonics (except the fundamental) are absent.

Both Data Sheets 29 and 30 are intended primarily to provide a pictorial representation of the distribution of the harmonics. Limitation of size, however, controls the number of harmonics that can be included and the small amplitude of the higher harmonics makes the reading accuracy poor. In order to simplify the direct calculation of any required point Data Sheet No. 31 has been prepared.

The factor A_n in Equation (27) used for Data Sheet No. 29 may be rewritten in the form

$$A_n = \frac{1}{n(1-\beta)} \frac{1}{\pi} \left(\frac{\sin n\beta\pi}{n\beta\pi} \right)$$

Similarly for Data Sheet 30 we may rearrange equation (23a) into

$$B_n = 2s \left(\frac{\sin ns\pi}{ns\pi} \right)$$

where $s = \phi/2\pi = x/T$

Data Sheet No. 31.

On Data Sheet (31) is plotted the function

$$\frac{1}{\pi} \left(\frac{\sin \psi}{\psi} \right) \text{ and } \frac{\sin \psi}{\psi}$$

may be read off by the use of the diagonal line and the upper scale. Thus for example supposing we want to calculate the amplitude of the 12th harmonic for a saw-tooth with a 5 per cent. retrace time ($\beta = 0.05$) and also for a rectangular pulse with $s = x/T = 0.05$, then in both cases $\psi = 0.6\pi$

$$\text{and } \frac{1}{\pi} \frac{\sin \psi}{\psi} = 0.161$$

$$\text{and } \frac{\sin \psi}{\psi} = 0.505$$

and the amplitudes are :

$$\text{Saw-tooth} = \frac{0.16E}{1.6} = 0.0141E.$$

$$\text{Rectangular Pulse} = \frac{12 \times .95}{E \times 2 \times .05 \times .505} = 0.0505E$$

TABLE I.

Saw-tooth and Rectangular Waveforms

1		$e = -\frac{E}{\pi} \sum_{n=1}^{n=\infty} \frac{1}{n} \sin n\theta$ $= \frac{E}{\pi} \left[-\sin\theta - \frac{1}{2}\sin 2\theta - \frac{1}{3}\sin 3\theta + \dots \right]$		$e = E_s + \frac{2E}{\pi} \sum_{n=1}^{n=\infty} \frac{1}{n} \sin n\pi \cos n(\theta - \pi s)$ $= E_s \left\{ 1 + 2 \sum_{n=1}^{n=\infty} \left(\frac{\sin n\pi s}{n\pi} \right) \cos n(\theta - \pi s) \right\}$	9
2		$e = \frac{E}{\pi} \sum_{n=1}^{n=\infty} \frac{1}{n} \sin n\theta$ $= \frac{E}{\pi} \left[\sin\theta + \frac{1}{2}\sin 2\theta + \frac{1}{3}\sin 3\theta + \dots \right]$		$e = E_s + \frac{2E}{\pi} \sum_{n=1}^{n=\infty} \frac{1}{n} \sin n\pi s \cos n\theta$ $= E_s \left\{ 1 + 2 \sum_{n=1}^{n=\infty} \left(\frac{\sin n\pi s}{n\pi} \right) \cos n\theta \right\}$	10
3		$e = -\frac{E}{\pi} \sum_{n=1}^{n=\infty} \frac{1}{n} \cos n\pi \sin n\theta$ $= \frac{E}{\pi} \left[\sin\theta - \frac{1}{2}\sin 2\theta + \frac{1}{3}\sin 3\theta - \dots \right]$		$e = \frac{E}{2} + \frac{2E}{\pi} \sum_{n=1}^{n=\infty} \frac{1}{n} \left(\sin \frac{n\pi}{2} \right) \sin n\theta$ $= E \left\{ \frac{1}{2} + \frac{2}{\pi} \left[\sin\theta + \frac{1}{3}\sin 3\theta + \frac{1}{5}\sin 5\theta + \dots \right] \right\}$	11
4		$e = -\frac{E}{\pi^2 p} \sum_{n=1}^{n=\infty} \frac{1}{n^2} \cos n\pi \sin n\pi \sin n\theta$ $= (-1)^{n+1} \frac{E}{\pi^2 p} \sum_{n=1}^{n=\infty} \frac{1}{n^2} \sin n\pi \sin n\theta$		$e = \frac{E}{2} + \frac{2E}{\pi} \sum_{n=1}^{n=\infty} \frac{1}{n} \sin \frac{n\pi}{2} \cos n\theta$ $= E \left\{ \frac{1}{2} + \frac{2}{\pi} \left[\cos\theta - \frac{1}{3}\cos 3\theta + \frac{1}{5}\cos 5\theta + \dots \right] \right\}$	12
5		$e = -\frac{E}{\pi^2 p} \sum_{n=1}^{n=\infty} \frac{1}{n^2} \cos n\pi \sin n\pi \sin n\theta$ $= (-1)^{n+1} \frac{E}{\pi^2 p} \sum_{n=1}^{n=\infty} \frac{1}{n^2} \sin n\pi \sin n\theta$		$e = E(s+p) + \frac{2E}{\pi p} \sum_{n=1}^{n=\infty} \frac{1}{n} \sin n\pi s \sin n(p+\pi) \cos n\theta$ $= E \left\{ (s+p) + \frac{2}{\pi} \sum_{n=1}^{n=\infty} \left(\frac{\sin n\pi s}{n\pi} \right) \sin n(p+\pi) \cos n\theta \right\}$	13
6		$e = -\frac{4E}{\pi} \sum_{n=1}^{n=\infty} \frac{1}{n^2} \cos n\pi \sin \frac{n\pi}{2} \sin n\theta$ $= \frac{4E}{\pi} \left[\sin\theta - \frac{1}{9}\sin 3\theta + \frac{1}{25}\sin 5\theta + \dots \right]$		$e = E\rho + \frac{2E}{\pi^2} \sum_{n=1}^{n=\infty} \frac{1}{n^2} (\sin n\pi \rho)^2 \cos n\theta$	14
7		$e = \frac{2E}{\pi} \sum_{n=1}^{n=\infty} \frac{1}{n^2} \sin^2 \left(\frac{n\pi}{2} \right) \cos n\theta$ $= \frac{4E}{\pi} \left[\cos\theta + \frac{1}{9}\cos 3\theta + \frac{1}{25}\cos 5\theta + \dots \right]$		$e = \frac{E}{\pi} \left(\frac{1-\cos\beta}{\beta} \right) \left\{ \sin(\beta-\beta\cos\beta) + \sum_{n=1}^{n=\infty} \left[\frac{\sin(n+1)\beta}{n+1} + \frac{\sin(n-1)\beta}{n-1} - \frac{2}{n} \cos\beta \sin n\beta \right] \cos n\theta \right\}$	15
8		<p>To introduce the D.C. component into waveforms 1-7 e.g. as in 8, add $E/2$ to e</p> <p>To express equations in terms of frequency write $\sin n\theta = \sin n\omega t$ or $\cos n\theta = \cos n\omega t$ where $\omega = 2\pi f$.</p>		$e = \frac{2E}{\pi} \sum_{n=1}^{n=\infty} \frac{1}{n^2} \left(\sin \frac{n\pi}{2} \right) \left\{ \sin(\beta-\beta\cos\beta) + \sum_{n=1}^{n=\infty} \left(\cos \frac{n\pi}{2} \right) \left[\frac{\sin(n+1)\beta}{n+1} + \frac{\sin(n-1)\beta}{n-1} - \frac{2}{n} \cos\beta \sin n\beta \right] \cos n\theta \right\}$	16

**HARMONIC COMPONENTS OF A SAW TOOTH WAVE
UP TO THE TENTH HARMONIC**

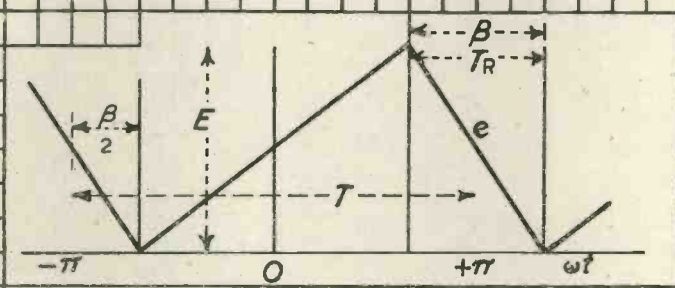
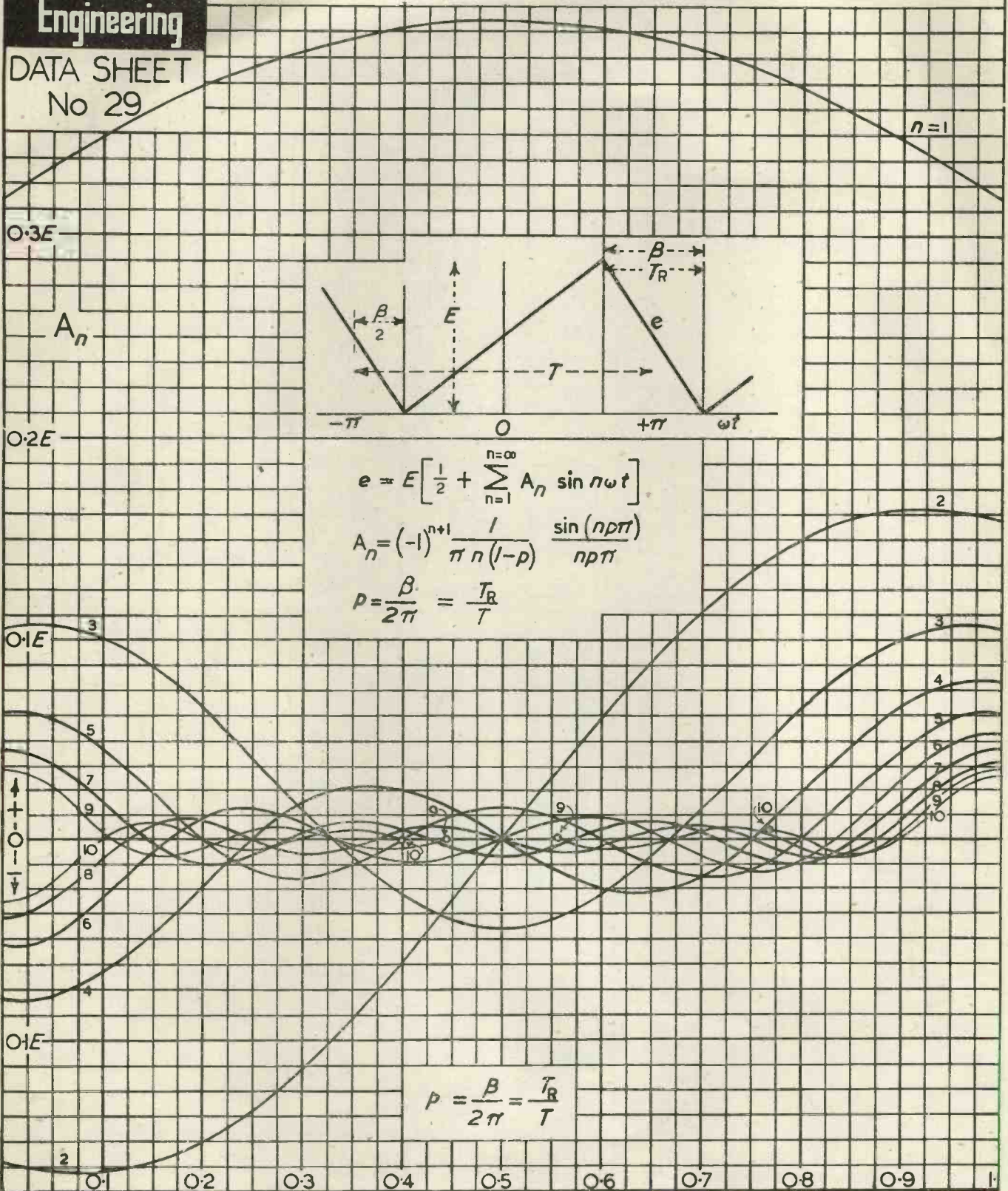

$$e = E \left[\frac{1}{2} + \sum_{n=1}^{n=\infty} A_n \sin n\omega t \right]$$

$$A_n = (-1)^{n+1} \frac{1}{\pi n(1-p)} \frac{\sin(np\pi)}{np\pi}$$

$$p = \frac{\beta}{2\pi} = \frac{T_R}{T}$$

$$p = \frac{\beta}{2\pi} = \frac{T_R}{T}$$

Electronic Engineering

DATA SHEET
No 30

HARMONIC COMPONENTS OF RECTANGULAR PULSES UP TO THE 10th.

$n=1$

HALF VALUE OF D.C. COMPONENT

B_n

0.6E
0.5E
0.4E
0.3E
0.2E
0.1E
0.0E
-0.1E
-0.2E
-0.3E

0.1 0.2 0.3 0.4 0.5 0.6 0.7 0.8 0.9 1

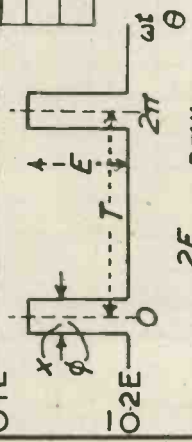

$$B_n = \frac{2E}{n\pi} \sin \frac{n\pi x}{T}$$

$$S = \frac{x}{T} = \frac{\phi}{2\pi}$$

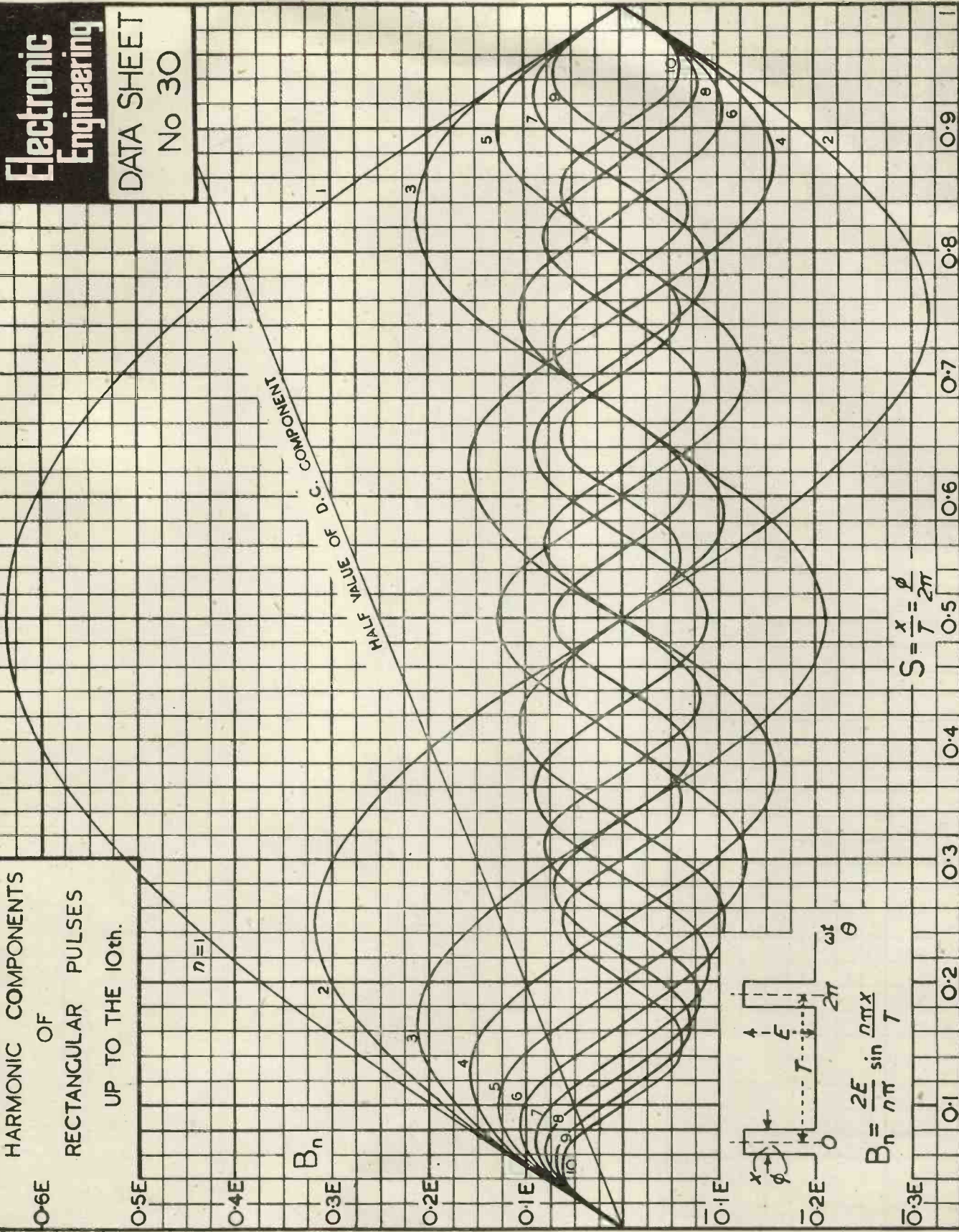

Electronic Engineering

DATA SHEET
No. 31.

VALUES OF
 $K = \frac{1}{\pi} \cdot \frac{\sin \psi}{\psi}$
AGAINST ψ

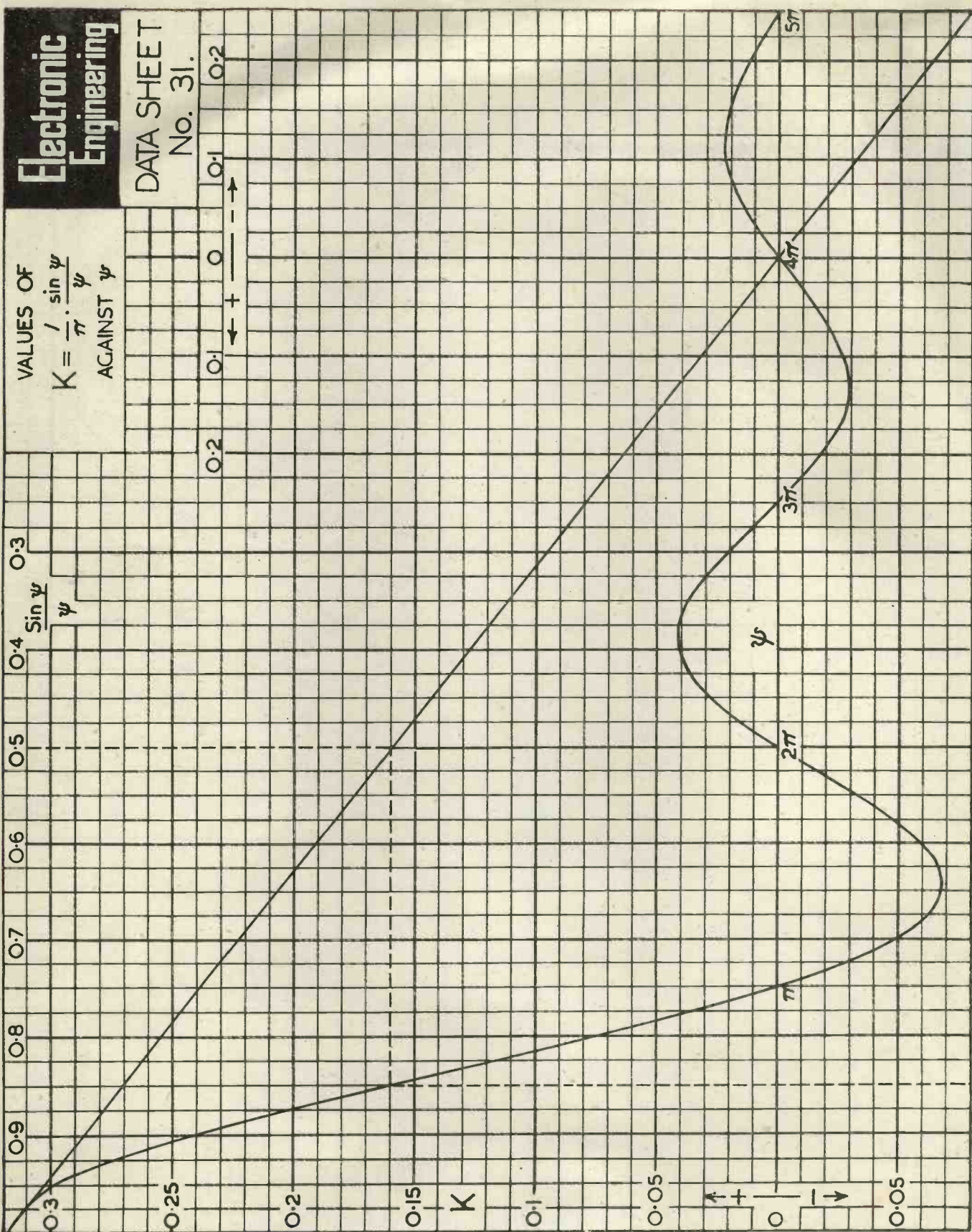

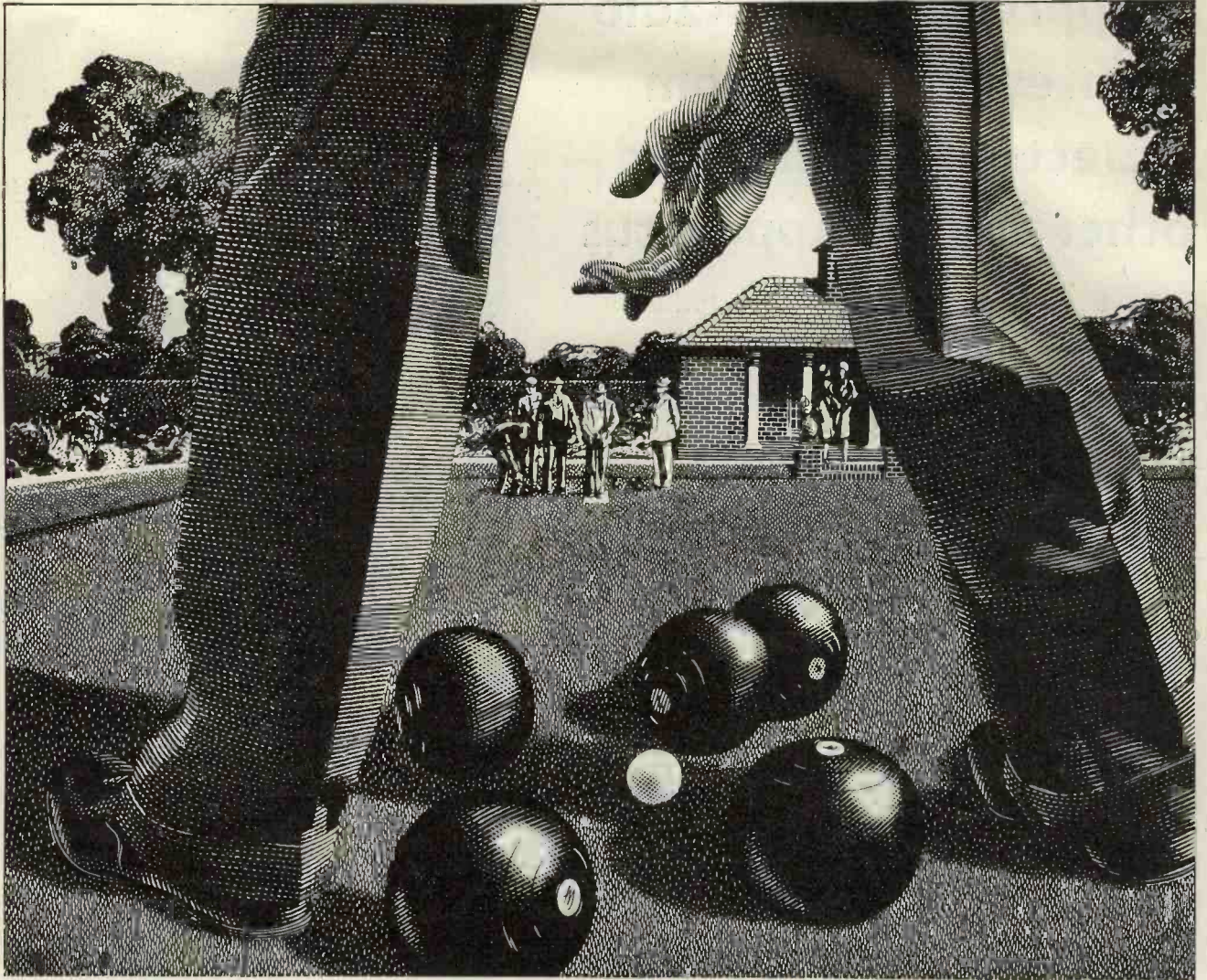

The Set Objective

A hand beckons . . . the 'wood' describes a graceful arc and comes slowly to rest. With Mullard, too, the beckoning hand of world events shapes a course for progress to follow. And Mullard technical skill is

guided and directed towards that end. The new developments in electronic technique taking place in Mullard laboratories and factories today will determine the trend of manufacturing policy for years to come.

MULLARD

THE MASTER VALVE

TRANSMITTING AND RECEIVING VALVES FOR COMMUNICATIONS · BROADCASTING
TELEVISION · SOUND AMPLIFICATION · ELECTRO-MEDICAL EQUIPMENT · INDUSTRIAL EQUIPMENT

THE MULLARD WIRELESS SERVICE COMPANY LIMITED, CENTURY HOUSE, SHAFTESBURY AVENUE, LONDON, W.C.2

Suppression of Radio Interference from Electro-Medical and other H.F. Apparatus

By E. F. H. GOULD, B.Sc., A.M.I.E.E.

In this article, which is reproduced by permission of the *P.O.E.E. Journal*,* the author shows that the most practical method of suppressing high frequency radiation from diathermy sets, induction furnaces and eddy current heaters, etc., is by electrical screening; examples of methods of screened rooms and of screening cubicles are given.

THERE are certain classes of apparatus in domestic, professional and commercial use which depend for their operation upon the generation of high frequency currents. Examples of the type of apparatus concerned are violet ray treatment sets, long and short wave diathermy sets, high frequency induction furnaces and eddy current heaters. It has been estimated that before the war there were hundreds of thousands of the first type of apparatus in use in this country of which a large proportion were in the possession of private persons for treatment in their homes. The diathermy apparatus was in use for specialised surgical purposes, but mainly for the treatment of rheumatism and similar complaints, and it was estimated that there were about 5,000 such sets in use. The third and fourth types of apparatus are used commercially, and in all there were probably less than 100 installations. The high frequency power used by the various equipments ranges from a few watts in the violet ray sets to hundreds of kilowatts in the electric furnaces and, as a consequence, interference with radio and communication could be expected.

Prior to the outbreak of war, interference with broadcast reception from the above-mentioned sources had not been particularly marked. This was due to the field strength from the broadcasting stations being sufficient to ensure an adequate signal to interference ratio, but a noteworthy exception was the interference caused to television reception by some types of diathermy sets, in those instances where the high frequency apparatus and the television receiver were close together. The rapid increase in the number of users

of high frequency apparatus and the contemplated expansion of the television and short wave broadcasting made it necessary to find a solution to this problem.

Experience with all types of diathermy apparatus leads to the following conclusions. Spark gap type sets give rise to radiation which is almost continuous over a wide range of frequencies. Valve sets usually produce only harmonics of the fundamental, but other frequencies have been observed. The radiation of the fundamental (or nominal frequency) is not always the most pronounced and, lastly, that at distances greater than 25 yards the radiation is roughly inversely proportional to the separation from the source. Typical results for long wave sets of the valve and spark gap type at a distance of 10 yards from the set are given in Fig. 1.

Valve-operated furnaces and eddy current heaters are less frequently met with, but are becoming more popular.

The most serious interference by mains-borne H.F. currents is caused to radio receivers connected to the same electric mains, but interference can also occur due to the mains acting as an aerial. The asymmetric H.F. currents flow out along the electric conductors in parallel and return through the earth path, in this way radiating the interference. The H.F. voltage across the mains supplying the H.F. equipment is in general of similar frequency composition to the directly radiated field from the same equipment.

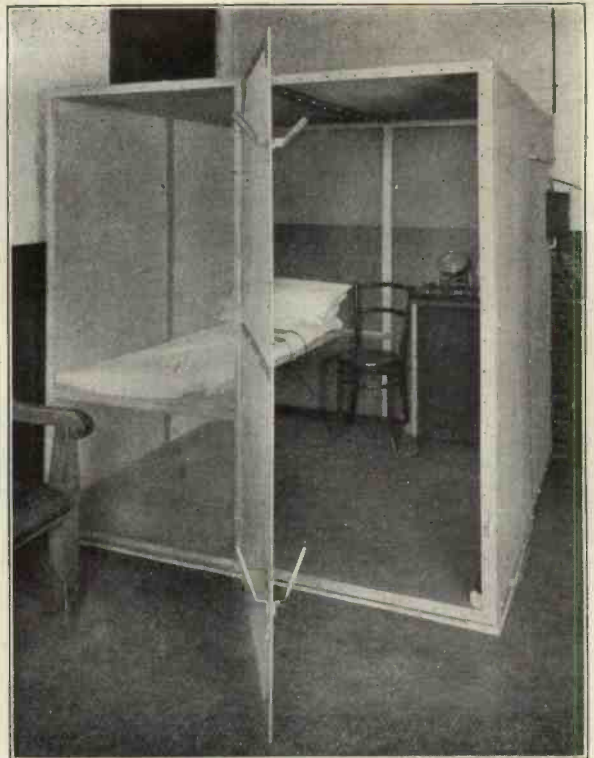
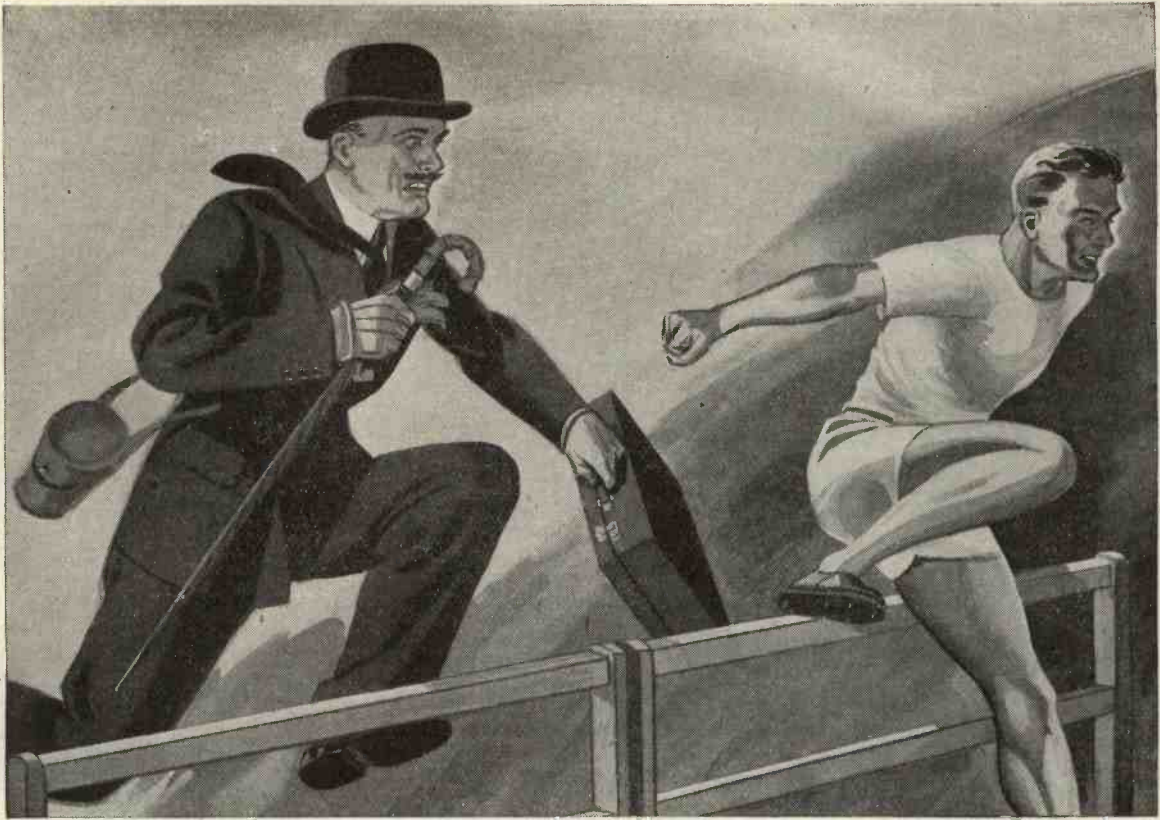

Fig. 4. Screening cubicle of expanded metal.

Methods of Suppressing Interference

From the manner in which this type of apparatus is used it is impossible to make it inherently non-radiating, although it has been demonstrated with violet ray sets, for example, that by a re-design of the apparatus to reduce the dimensions of the output circuit a marked reduction in the radiation can be achieved. This method has not been adopted owing to the cost. The only alternatives which would give the most general relief would be (a) to allocate certain wave-lengths for the exclusive use of high frequency apparatus or (b) to enclose the equipment and everything associated with its output circuit in an earthed screen and to fit suppressors in all conductors entering or leaving the screened space.

If the screening is to be effective it is essential that the whole of the H.F. circuit should be enclosed within a complete earthed screen, which for diathermy treatment means that the patient must be included. Although the screen need not be of continuous metal, all sections must be securely bonded together and whereas wire mesh, expanded metal or metal foil are suitable materials, metal paint is not satisfactory as the binding material insulates the particles of metal from one another. The results of tests on various materials for the screening of diathermy apparatus are given in Table I. It will be seen that for the higher frequencies the more open type mesh is less effective.



Impedimenta

SOME industrialists are still taking their manufacturing hurdles without stripping for the race.

The mental sprinters have long since discovered that to call in the Simmonds Organization during the design stage is to avoid unnecessary experiments, to save time, to reduce the cost of the product, to ensure its efficiency.

S I M M O N D S

THE SIMMONDS "1/32" NUT
SIMMONDS-CORSEY CONTROLS
SIMMONDS CONTENTS GAUGES
FOR AIRCRAFT.
SIMMONDS POSITION INDICATORS
SIMMONDS ELECTRIC TEMPERATURE
AND PRESSURE GAUGES
SIMMONDS AIRCRAFT FLOORING



SPIRE "1/32" NUTS
FRAM OIL & ENGINE CLEANER
SIMMONDS INDUSTRIAL AND
MARINE CONTENTS GAUGES
SIMMONDS JOINTING COMPOUND
SIMMONDS CRYSTAL UNITS
SIMMONDS-GOUDIME
NAVIGATIONAL INSTRUMENTS

SIMMONDS AEROCESSORIES LTD

A COMPANY OF THE SIMMONDS GROUP
LONDON · MELBOURNE · PARIS · NEW YORK

P.5.

ALL ENQUIRIES TO GREAT WEST ROAD, LONDON.

TABLE I

Material.	Frequency Mc/s.	Suppression due to Screening (db).
$\frac{1}{2}$ -in. wire mesh ...	45.0	40
$\frac{1}{4}$ -in. wire mesh ...	0.19	64
	1.0	60
	15.0	55
	45.0	45
$\frac{1}{4}$ -in. wire mesh ...	45.0	56
	0.15	48
Paper-back metal foil	45.0	56
$\frac{1}{2}$ -in. steel sheet with welded seams ...	50.0	72
Double Screening		
Inner and outer, both		
$\frac{1}{4}$ -in. wire mesh ...	50.0	83
Inner screen metal foil, outer screen metal faced plywood ...	50.0	96

In conjunction with the screening of the apparatus all electric conductors, including telephone wires, entering the screen must be fitted with filters (close to where they enter the screen) to prevent the high frequency currents from being propagated outside the screened space. The effectiveness of the filter unit will, for any design, depend upon the impedance of the mains to which it is connected.

The filter must be designed to suppress symmetric as well as asymmetric components and an example of a filter recommended for general use in connexion with high frequency apparatus is shown in Fig. 2. It is essential that the separate non-inductive type condensers should be used, that all leads to them should be as short as possible and that the filter should be enclosed in an earthed screening box. Other conductors which are sometimes found to enter or pass through the screened room or enclosure, for example, heating pipes or cable conduits, should be securely bonded to earth.

Practical Considerations and Examples of Screening

From the point of view of appearance it is desirable to have the screening under the wall fabric, and if the screening is decided upon at the time the place is being built this can be done quiet easily by the use of wire gauze. For an existing room the walls, floor

and ceiling can be satisfactorily dealt with by paper-backed metal foil, which, with suitable wall treatment afterwards, gives a pleasing appearance. A false ceiling at, say, 7 ft. or so, made of wire gauze, will enable the lighting fixture to be left outside the screen and so obviate the filtering of the conductors to them. In this connexion it will often pay to re-route electric services not essential in the screened space so that they do not enter or pass through it.

Considering now, in more detail, the screening of a room during the building construction. Wire gauze should be fixed to the walls and ceiling before they are plastered and before the floor is laid. Galvanised iron wire gauze, 25 S.W.G. of $\frac{1}{4}$ in. mesh, is quite suitable and is available in rolls 6 ft. 6 in. wide at approximately 4d. per foot. An overlap of $\frac{1}{2}$ in. should be allowed between adjacent strips and at the joints between walls, floor and ceiling. A soldered connexion should be made every foot at the overlap joints. The plaster used for covering the screening should not have a strong alkaline reaction as this would corrode the wire gauze. Any normal finish, such as distemper, paint or wall paper, can be applied to the wall or ceiling. The doors can be covered with metallised paper, or wire gauze can be sandwiched between two layers of wood, or the door can be covered with sheet metal or

metal-faced plywood. The connexion between the door screening and the rest of the screen can be made through the hinges and ball catches provided they are of non-rusting metal and unpainted. It is usually required to open the windows, and the screen should therefore take the form of a separate metal framework covered with $\frac{1}{4}$ in. mesh wire gauze in good electrical contact with the rest of the screening. If the windows are not to be opened, $\frac{1}{4}$ in. mesh wire reinforced glass in metal frames could be used, but the standard $\frac{1}{2}$ in. wire gauze is not suitable.

The most economical and usually the most convenient method of screening an existing room, except where tiled or painted walls are concerned, is to paper the walls and ceiling with metal foil and to treat the floor, windows and doors in a similar manner to that described above for screening a room in the course of construction. To facilitate the handling and hanging of the metal foil it is usual to use a paper-backed foil. Aluminium or zinc foil, .009 mm., thick on a 60-gramme paper back, is a commercial article obtainable in rolls 14 in. or 20 in. wide. All wall fittings, which would cause a gap in the screening larger than 2 in. diameter approx., should be removed and the paper hung in the same way as ordinary wall paper backing to the wall, and the metal foil exposed, after which the fixtures can be replaced. Any paste, provided it is not strongly alkaline, is suitable, and at joints between adjacent strips a 2 in. wide strip of foil held in position by a wooden lath should be used to overlap the joint so as to ensure the continuity of the screen. Ordinary stuck joints are not suitable as they deteriorate in time. Metal foil strip for this purpose is obtainable but, if desired, a strip of paper-backed foil could be used, and care should be taken to see that the paper backing is towards the wood lath. With regard to the floor, the wire gauze can be laid on the existing floor and covered with a material such as linoleum for mechanical protection. The contact between the wire mesh gauze and the

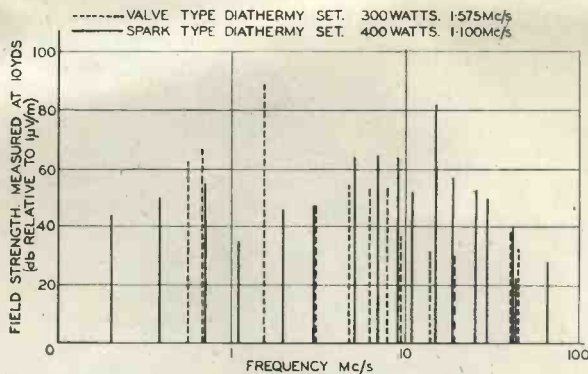

Fig. 1. Graph of Field Strength/Frequency.

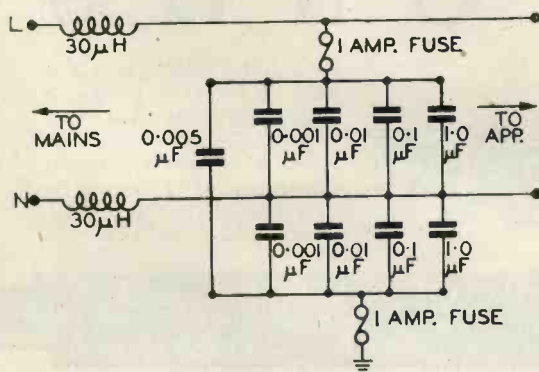

Fig. 2. Filter circuit for use with High Frequency Apparatus.

(Concluded on p. 35.)



DISTRENE

REGISTERED
(POLYSTYRENE)

in sheets, rods and tubes ★

THE IDEAL PLASTIC FOR HIGH FREQUENCY ELECTRICAL INSTALLATION

for particulars of sizes and prices apply:—

BX Plastics Ltd., Hale End, London, E.4

Vibrator Waveforms

By S. L. ROBINSON*

USERS of vibrator-operated power supply units will no doubt be fully aware that, provided the maker's rating of the vibrator is not exceeded, and that the waveform is correct, extremely long life can be expected before the vibrator needs replacing. It is the writer's intention to describe briefly the importance of the waveform, and illustrate a few of the most commonly met faults.

In Fig. 1 the action of the contacts of a vibrator is illustrated as an electro-mechanical waveform trace, plotted against time. At 1 in the diagram, the contacts are closing on one direction of the swing of the reed, and connecting the primary of the transformer in effect to the positive of the battery, the contacts remaining closed until point 2, this length of time being t_1 . The reed now requires a period of time to swing to the other contact, the closing of which takes place at point 3, and now connects the transformer to the negative terminal of the battery. These contacts remain closed for the length of time t_2 , and on reaching point 4, where once more the contacts break, complete a cycle of operations.

Current can only flow from the battery while the contacts are closed during the periods t_1 and t_2 , since the power is in effect reversed on each half cycle, an alternating current is applied to the associated circuit in the waveform shown in Fig. 1. The amount of energy transfer can be calculated by the ratio of time the contacts are closed to total time, and this is known as "Time efficiency," being shown mathematically as a percentage, and can be calculated by use of the following formula:—

$$t_1 + \frac{t_1 + t_2}{t_2 + t_1} + t_2$$

The time efficiency of a modern vibrator is in the neighbourhood of 85 to 90 per cent., dropping slightly as the contacts wear in use, and in relation to the D.C. supply, it can be compared with the difference between maximum and r.m.s. values in an A.C. circuit. The waveform obtained in Fig. 1 will only be obtained if the vibrator is operating in a purely resistive load. When an inductive circuit, such as a transformer is connected, a fixed capacity or "buffer condenser" is required to protect the circuit during the intervals of time that the contacts are open to t_2 and t_1 . If no buffer condenser is used, when the contacts open at point

2, an exceedingly high voltage of the opposite polarity will be induced across the contacts, owing to the collapse of the magnetic field which is suddenly broken. This would cause severe arcing at the contacts, and would lead to early breakdown of the vibrator. Also, when the contacts closed at point 3 the full battery voltage would be applied across the contacts and more arcing would take place.

By connecting a condenser of the correct capacity across the primary or secondary windings of the transformer, the waveform trace can be altered to Fig. 2. It will be noticed that the "open contact" intervals t_2 and t_1 have disappeared as horizontal lines and appear as slopes between points 2 and 3, and 4 and 5. This is the perfect waveform for an interrupter type or a self-rectifying type of vibrator operated "off load." The buffer condenser has in effect, become a tank in which energy is stored during the "open contact" periods t_2 and t_1 , and which discharges during the "closed contact" intervals t_1 and t_2 .

When the contacts open, the magnetic circuit is broken and the flux collapses inducing a voltage which charges up the buffer condenser. When the voltage reaches zero, the condenser is fully charged and proceeds to discharge back into the magnetic circuit building up a magnetic field in the opposite direction. This is, in effect, similar to an oscillatory circuit, the time constant being governed by the inductance of the transformer and capacity of the buffer condenser, and this discharge and recharge takes the form of a damped oscillation. However, the timing is so arranged that the first quarter-cycle is never completed, and the contacts close again to make another half-cycle. The ideally perfect waveform of Fig. 2 shows the contacts exactly as the induced voltage equals the applied voltage, and though it can be achieved in the laboratory, is not practical in production, owing to the variations met in the various components used in the circuit. Also, as the vibrator contacts wear away, and the time efficiency decreases, a larger buffer condenser is theoretically required for a worn vibrator than an unused one, and allowance must be made for this when originally deciding the size of condenser to be used. A compromise has therefore to be adopted, and a desirable waveform for a new vibrator would appear to be slightly over-buffered as in Fig. 3. After slight initial wear on the contacts, the waveform will improve and will approximate to Fig. 2.

A self-rectifying vibrator can be considered as an ordinary interrupter type when operated off load, but when a load is applied to the correctly adjusted circuit, the waveform should appear as in Fig. 4. The short regular peaks shown at start and finish of the time periods t_1 and t_2 are correct and do not create "hash" or circuit difficulties, if they appear similar to those illustrated. These peaks are created by the increased voltage drops in the primary or L.T. circuit when the secondary or H.T. load is connected, since the vibrator is adjusted so that the primary contacts close just before the secondary contacts close, and open just after the secondary contacts open. In other words, the secondary contacts are arranged with slightly wider gaps than the primary contacts, thus allowing the load to be broken while the voltage is steady, instead of rising or falling rapidly, the advantages of which are obvious.

Correctly shaped waveforms have been illustrated, but a few examples of poor waveform may be of interest, and even of help where it has become necessary to replace an old .85-cycle and 80 per cent. time efficiency with a modern 115-cycle and 90 per cent. efficiency type. The "open contact" periods t_2 and t_1 would be considerably shorter, and with a shorter time period the buffer condenser, which was correct for the old type vibrator, is now too large for the replacement, and the waveform of Fig. 5 results. Should the reverse take place, or in a case where the original buffer condenser capacity is too small, the waveform will appear as in Figs. 6 and 7.

Fig. 6 illustrates a case of "over-closure" of the waveform of an interrupter type of vibrator with a load applied to the rectifying valve. This condition is not frequently met with, and can easily be mistaken for bouncing of the contacts at the "make." However, if the vibrator is operated off load by removing the rectifier from its socket, the picture will change to the waveform as shown in Fig. 7: a case of over-closure can obviously be cured by the addition of capacity.

It may be mentioned that condensers are in much the same way as springs, and it is worth while replacing such hard worked components as buffer condensers after a considerable running time. In the case of self-rectifying vibrators, the very sharp and ragged points will be apparent instead of the

* Masteradio, Ltd.

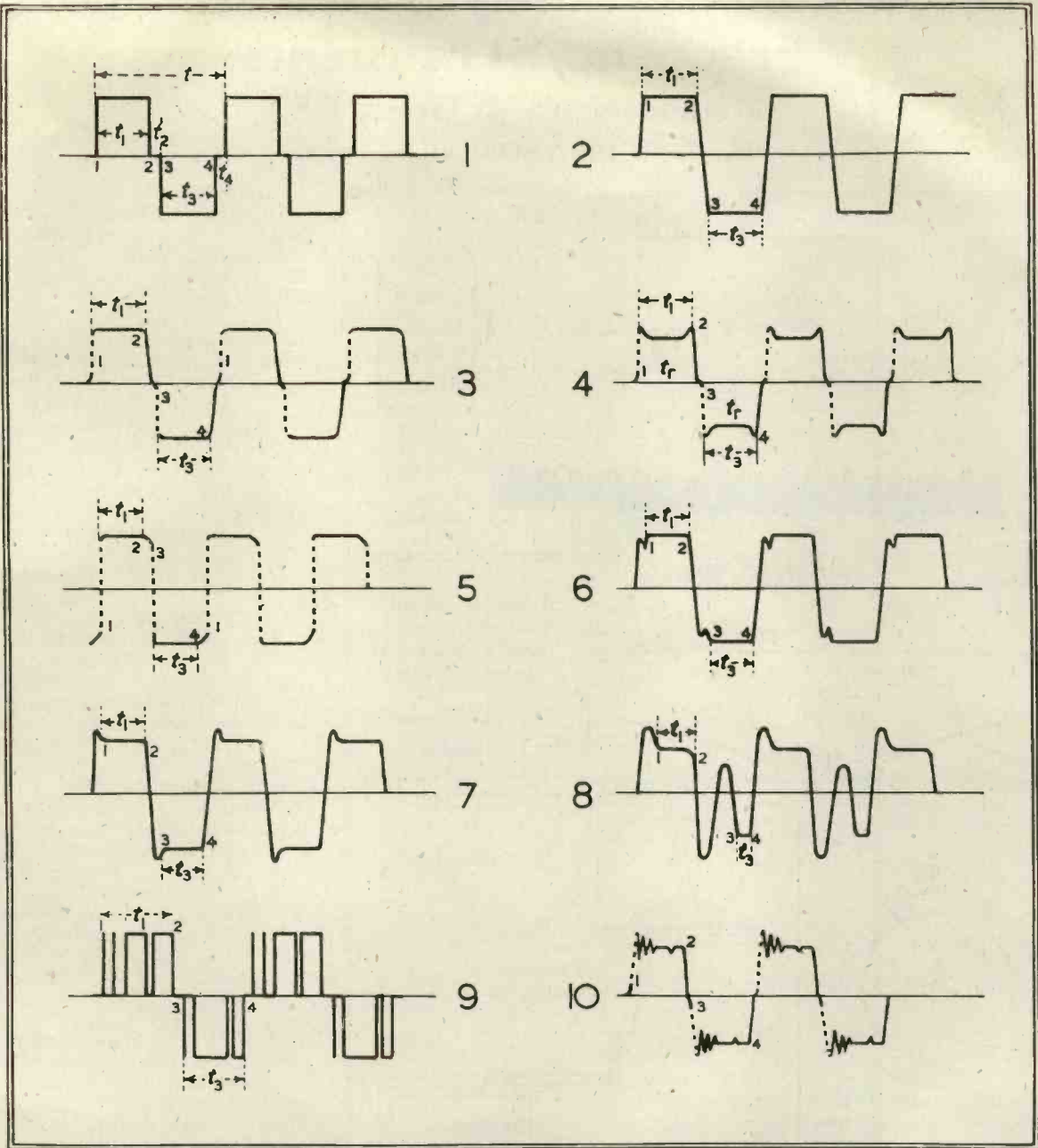

more rounded ones illustrated. These curves are dangerous, and will cause a breakdown of the vibrator or some other component, since the transient voltages are usually much higher than the value shown on the oscillograph screen, and are multiplied by the transformer turns ratio when applied to the secondary circuit.

It should be noted that all the waveforms illustrated are obtained by connecting the vertical plates of the oscillograph across the entire primary of the vibrator transformer, except in the case of Fig. 2 which can be reproduced by

substituting a centre tapped resistance for the transformer primary.

When deciding on the value for a buffer condenser, checks should be made when applying the two extremes of battery voltage likely to be met, so that a value giving the best all round results can be found.

The condition of "hopping," *i.e.*, the vibrator operating mainly on one pair of contacts only, can be recognised by waveform as in Fig. 8. This is a situation where more than one cycle of oscillatory discharge from the buffer condenser has taken place before the

one set of contacts close at point 3, while the other set of contacts give comparatively good operation, except that the time interval t_1 is short and the reed amplitude is low.

Bouncing or "chatter" of contacts will produce waveform traces as in Fig. 9 when operating with a centre tapped resistance, and as in Fig. 10 when a transformer/condenser circuit is used.

The faults illustrated in Figs. 9 and 10 are usually caused by inherent faults in the vibrator itself, and the only definite cure is replacement of the vibrator.

The Automatic Analysis of Ultra Low Frequency Transients

(Method of A. M. Grass, B.S.)

By G. D. DAWSON, M.Sc., M.B.*

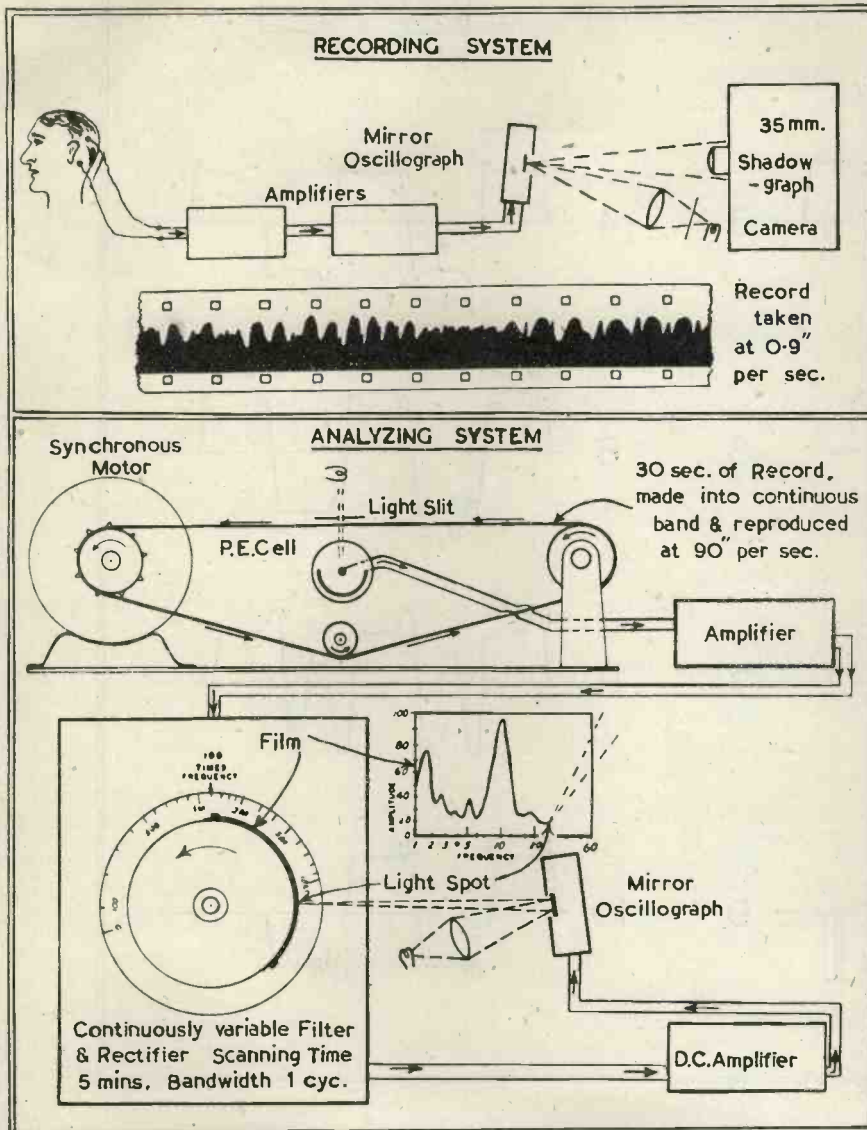

THE waves of potential from the human brain recorded by means of an amplifier and oscillograph, show a range of frequencies varying from below one cycle per second to about fifty cycles per second. These waves appear in long runs, short runs or singly, and may be sinusoidal or distorted by regularly placed or irregular spikes and humps.

With practice an observer can easily recognise the grosser abnormal wave-forms associated with certain diseases. However, any change such as a general

increase or decrease of frequency of the most prominent groups is difficult to assess. Various indices have been devised for describing such changes. For example the percentage of a given recording time that a certain frequency is present in the record has been used. This is unsatisfactory as it takes no account of varying amplitudes. Counting up the various frequencies in the record is tedious and impracticable when a large number of records has to be examined. Also the results are not generally very informative, and some method of analysis quite independent of the observer is desirable.

An ingenious and satisfactory method of analysing the electro-encephalogram into its component frequencies, and automatically plotting the amplitude of these, has been described by A. M. Grass.¹

This method has been used successfully by Gibbs and his collaborators² for a number of investigations which would otherwise have been impracticable.

The difficulty of analysing the electro-encephalogram objectively lies in the very low frequencies involved (1 to 50 c.p.s.), and the fact that these waves are never truly repetitive and are mostly of a transient type. Grass overcomes this difficulty in the following manner.

A record is taken on cine film, with a reflecting oscillograph, in the form of a "variable area" trace. (Fig. 1a). The recording rate of the film is fixed at a convenient speed, in his case 0.9 in. per second. A representative length of record about 30 inches long is taken and the ends spliced to form a continuous belt. This belt can be driven past a slit at 90 in. per second, one hundred times the recording speed, by a synchronous motor. (Fig. 1b). The slit is illuminated and the light passing through the film from it is collected by a photo cell. A frequency band between 100 c.p.s. and 5,000 c.p.s. is thus produced by the light variations on the cell. These frequencies are fed to, and analysed by a standard wave analyser.

Automatic plotting of the frequency-amplitude curves is obtained as follows: Coupled on to the frequency control of the analyser is a drum carrying a piece of photographic paper. Rotation of the control thus produces the frequency axis of the graph and is carried out automatically at such a rate that the range 100 c.p.s. to 5,000 c.p.s. is covered in five minutes. The output of the analyser is fed after rectification, to a mirror galvanometer. The light from this is arranged to traverse the photographic paper parallel to the axis of the drum thus producing the amplitude axis of the graph.

An analysis of a record from a normal person (A) with the eyes closed (B) with the eyes open, but not concentrating and (C) with the eyes open and attention fixed on reading is shown in Fig. 2. A, B, C. The speeding-up of the prominent peak at 10 c.p.s. in A through 11 c.p.s. in B to 12 c.p.s. in C, and the great augmentation of the energy in the 7.5 c.p.s. and 20 c.p.s. bands in C is well shown.

The value of such an objective

* The David Lewis Colony and Department of Electroencephalography, Manchester Royal Infirmary.

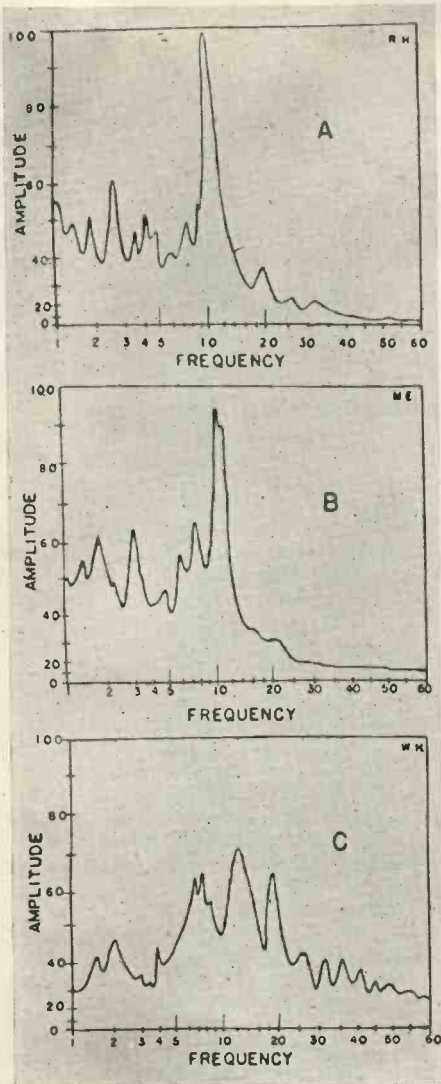

Fig. 2.

analysis is great, but the authors stress rightly, that it can never replace, but only supplement, an examination of the record by an observer. The reason for this is that an otherwise normal record may be classed as definitely abnormal on account of a single abnormal wave if this is sufficiently distinct. In the automatic analysis the energy in such a single wave will be averaged out over 30 seconds of recording and if its period is $\frac{1}{3}$ or $\frac{1}{4}$ of a second it will be completely lost in the analysis which will appear normal. Provided this limitation is borne in mind the method is a most useful addition to electro-encephalographic technique.

1. GRASS, A. M. and GIBBS, F. A. "A Fourier Transform of the Electro-encephalogram. *J. Neurophysiol.* 1938, No. 1, p. 521.
- 2a. GIBBS, F. A., WILLIAMS, DENIS and GIBBS, E. L. *J. Neurophysiol.* Jan., 1940., III, p. 49.
- 2b. GIBBS, F. A., LENNOX, W. G. and GIBBS, E. L. *Arch. Neurol and Psychiat.*, Oct., 1941, Vol. 46, p. 613.

Suppression of Radio Interference from Electro-Medical and other H.F. Apparatus (Continued from page 30)

Fig. 3. Screening for Walls, Ceiling and Floors.

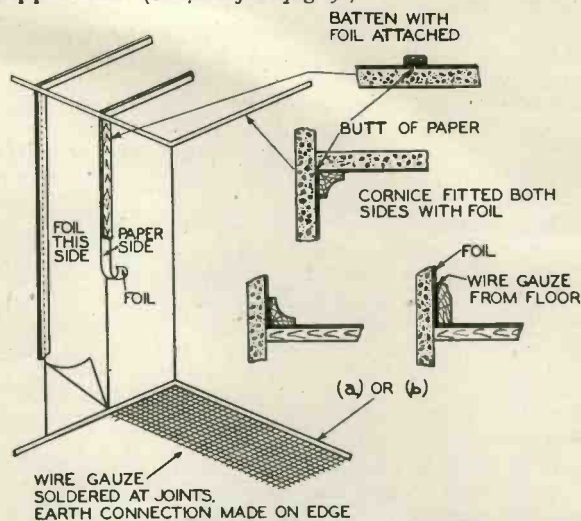

metal foil can be secured beneath the usual wood skirting boards. The details of the method are shown diagrammatically in Fig. 3.

Finally, the metal surface can be treated with paint or distemper for which purpose many of the well-known paint manufacturers market a suitable preparation and will readily give advice on this matter. Important points to be considered in this respect are the possibility of the paint or distemper causing chemical attack of the metal foil and the presence or grease on the foil which may affect the adhesion of the decorating material.

If the H.F. equipment is in a large room or if, for example, the doors or wall fittings are inconveniently placed it is worth while to consider screening only one corner of the room and confining the H.F. apparatus within that space. The screen must, of course, be complete, and if the corner walls are hung with paper-backed metal foil the remainder can be made in a similar manner to that described below for a transportable screen.

It has already been indicated that the screening of an existing room may present difficulties, or it may be that the H.F. apparatus is moved from one building to another. In such circumstances a screening cubicle is the best solution.

Expanded metal of $\frac{3}{16}$ in. mesh is suitable for screening H.F. apparatus, and for screened cubicle construction it has the advantage of being more robust than wire gauze. To ensure good electrical contact throughout, the expanded metal must be welded into a frame which is later bolted to the supporting ironwork.

A general view of a cubicle 6 ft. by 6 ft. of $\frac{3}{16}$ in. mesh expanded metal is shown in Fig. 4. This cubicle was made by the Expanded Metal Co. and cost approx. £25 complete with electrical fittings. Several of the electro-

medical supply companies have also produced screened cubicles for diathermy apparatus, and, in general, these are wire gauze on wood or metal frames.

Legislation to Control H.F. Apparatus

Except where the apparatus is used solely for surgical purposes or where the provision of the screening would interrupt the production of urgently needed articles, a condition of issue of the permit to possess high frequency apparatus is that it should be completely screened to the satisfaction of the Postmaster-General. Approved methods of screening high frequency apparatus are described in a pamphlet sent with each permit and any departures therefrom must be separately approved. The pamphlet embodies in detail the screening methods dealt with generally, earlier in this article.

For the purpose of the Order, high frequency apparatus is defined as "any apparatus that generates or uses, and has a maximum output exceeding 10 W of electrical energy at a frequency exceeding 10 kc/s, not being wireless transmitting apparatus." The principal types of apparatus to which the order applies are:—

- (a) Diathermy and electro-medical apparatus using valves or spark coils, frequently known as ultra-short, or short, or long wave diathermy, surgical diathermy or therapy apparatus.
- (b) High frequency furnaces.
- (c) Eddy current heating apparatus such as is used by valve and electric lamp manufacturers.
- (d) Testing oscillators with a high frequency output exceeding 10 W.

On the other hand, it does not apply to the normal type of violet ray equipment, to X-ray apparatus, infra-red and ultra-violet ray apparatus, medical shocking coils or to wave-meters and low-powered testing oscillators such as are used by radio dealers.

German Aircraft Radio (Continued from p. 12.)

by indication of a milliammeter. This is effected by reversing the phase of the signal from the aerial and hence the cardoid formed by the combined polar diagram of the loop and aerial. At the same time the polarity of the meter is also reversed. When on course the signals on either phase are the same and there is no steady current through the meter.

For non-directional reception the sense aerial is duly coupled to the input stage by the loop aerial transformer. For figure-of-eight aural D.F. reception the sense aerial is used to provide zero clearing and is coupled in to the loop transformer through a differential condenser.

Screening

With the exception of B.A. and D.F. equipment the wiring and the radio apparatus is not screened. The transmitting, receiving and navigational power units are all filtered and screened. Both the communication and D.F. receivers are highly sensitive with a performance approximating to the ultimate limit of first circuit noise. In each case noise from the power unit was above that of the first circuit. Motors in the aircraft are suppressed with small condensers, but are not completely screened. The screening of the ignition system is not good and it is probable that the interference from the ignition and electric circuits limits the use of the receivers at full sensitivity.

R/T Equipment, FU. G.16.

This is a simpler form of communication transmitter and receiver operating on a frequency spectrum from 42.2 Mc/s. to 38.6 Mc/s. It is also intended for communication between aircraft.

While the tuning dials are fitted with the 4-position mechanism for alteration of "spot" frequency the tuning controls are not accessible in flight and there is no provision for fitting remote control. The equipment must therefore be used on one channel which is pre-set on the ground.

Receiver Design

The transmitter, receiver and associated circuits are in a single unit made up of three sections, the centre section containing the modulation amplifier, radiation meter and output transformer while the transmitter and receiver are on the right and left sides respectively.

The receiver circuit is a straightforward superhet with the following valves: r.f. amplifier, first det., oscillator, 3 i.f. stages, second det., A.G.C. rectifier, l.f. amplifier output. The same type of valve is used throughout—RV 12B/2,000, which is an r.f. pentode connected as a triode or diode as required.

The r.f. oscillator operates a signal frequency minus i.f. frequency, and

great care has been taken to ensure high frequency stability in the oscillator. The inductance is wound on a ceramic former, supported in a spiral groove. It would seem that this groove is first coated with a film of colloidal silver or copper which is then fired and the winding is built up to the required thickness by electro-plating on the film. Such an inductance has a very low temperature coefficient. The r.f. oscillator voltage is neon stabilised.

Coupling between the grid circuit of the r.f. amplifier and the aerial is very loose—merely a short length of interconnecting wire.

When tuning to the adjacent transmitter a push-button marked "Einpfeifen" (Whistling-in) reduces the sensitivity of the receiver. This device is common to the receiver circuits just described (FU.G.10) and simultaneously reduces the transmitter volts.

Transmitter

Two valves RL.12 P.35 are used, one as a master oscillator cum frequency doubler and the other as a power amplifier, with signal grid modulation.

The basic power supply is 24 v. from the aircraft battery, and this operates a compact dynamotor fitted with three commutators, one for the drive and the others for H.T. supply and grid bias.

The load is approximately 10 amps., the transmitter taking 210 mA. at 400 v. and the receiver 440 v. 85 Ma. Grid bias is 140 v. for the transmitter. The filament heating of the master oscillator is stabilised by a barretter which also contributes to the frequency stability.

EMERGENCY TRANSMITTERS

There are two types of emergency transmitter—N.S.1 and N.S.2, the latter being intended for use in dinghies. Type N.S.1 is a self-contained portable transmitter capable of C.W. transmission by hand or automatic sending. On automatic sending it transmits S.O.S. three times followed by a long dash. The wave band is 320-532 kc/s and the transmitter is tuned for a spot frequency of 500 kc/s. It is contained in a box 18 in. by 10 in. by 18 in., painted bright yellow and weather proof and weighing about 50 lbs. The aeriels are in a separate container which in appearance is similar to an aluminium golf club bag. One aerial consists of five sections of aluminium tube of a total length of five metres, with an "umbrella" capacity top. The other aerial consists of 165 ft. of stainless steel wire which is flown from a box kite stowed in the aerial container.

The transmitter unit is a triode master oscillator driving two more valves in parallel. The master oscillator is variometer tuned and the output stage is also tuned by a coupled condenser and variometer. Valves type RS 241 are used throughout.

Notsender N.S.2.

This is a more elaborate equipment in two parts: the transmitter and the accessory container, both of which are watertight, buoyant and painted a bright yellow. The transmitter is driven from a hand generator housed in an aluminium alloy box 11 in. by 10 in. by 7½ in. which is specially shaped to be held firmly between the knees. The handle for the generator is on top of the box and a compartment in front holds the aerial wire and flexible connexion, etc.

The mechanical construction of the transmitter is interesting in that no sub-chassis is used and the front panel holds all the components. The range over sea is 250 miles and over land 120 miles. The transmitter operates on one frequency only (500 kc/s) and is crystal controlled, this being the first case of the use of crystals in German aircraft radio equipment.

The oscillator and output valve is a Telefunken AL5N. The oscillatory circuit of a reaction coil and the crystal connected between grid and earth, and a tuned circuit which is in the screened grid circuit. The output circuits consist of an untuned choke closely coupled to the aerial coil. The tuning condenser incorporates a switch enabling the coil to be tapped to compensate for variations in the aerial capacity which occur as the angle of elevation of the aerial alters. The transmitter may be grid modulated by switching on the filament of the modulator valve (Telefunken RE13A) to enable M.C.W. to be transmitted if desired. The transmitter can also be set for automatic sending of S.O.S. and long dashes. The output into the aerial is 6.2 watts and the actual power radiated is 0.91 watts.

Aerials

The light alloy accessories container holds a kite, two balloons with filling tubes, two hydrogen generators and an instruction booklet. If the wind is more than 13 m.p.h. the kite is used, erected according to the instructions given in the booklet and marked on the kite. The aerial wire (260 ft. of stainless steel) is attached by a special hook and reeled out as the kite ascends. 10 ft. of stainless steel wire are thrown overboard with a sinker to form the earth wire.

With no wind one of the balloons is inflated by the hydrogen generator which is connected to it and immersed in sea water. The hydrogen is presumably generated by sodium or potassium. The balloon is inflated to one metre diameter and the aerial wire is fixed to the attachment provided as before.

Fig. 8 is a drawing of the transmitter and accessories and Fig. 3 shows the circuit.

NOTES FROM THE INDUSTRY

New Soldering Fluxes

In the March issue of *Tin and its Uses*, the review issued by the Tin Research Institute, a report appears on fluxes which leave non-corrosive residues and which are particularly suitable for fine work in consequence.

For soldering fine copper and copper alloy wires and hairsprings an aqueous solution of lactic acid is recommended with the addition of a wetting agent such as Calsolene Oil (I.C.I. Proprietary). The formula is: Lactic Acid 15 per cent. by vol. Calsolene 0.2 per cent.; Water 84.8 per cent.

A flux suitable for hand and dip-soldering which does not corrode copper or tinplate is:

Resin 20 per cent. by wt.; Aniline Hydrochloride 1 per cent.; Spirit 79 per cent., but this should not be used in the presence of steel parts owing to traces of free chloride vapour (which is poisonous in addition). When a non-corrosive flux leaving a non-greasy residue is required on tinplate the following may be used:

Resin 20 per cent. by weight; Lactic Acid 5 per cent. by wt.; Spirit 75 per cent. by wt.

Londex PR/S Timer

Messrs. Londex, Ltd., of 207 Anerley Road, London, S.E.20, have recently put on the market a shorter model of their well known Multi-Contact Process Timer, type PR.

The small timer Type PR/S, which is shown in the figure retains the flexible features of the larger PR model, and is fitted with easily interchangeable gearing between the synchronous motor and the cam shaft. Up to two standard cams and contact sets can be accommodated. In addition, a zero position motor stopping contact can be fitted optionally.

This timer is suitable for a number of automatic switching problems and has the advantage of saving both space and cost where it is not necessary to control more than two circuits.

Time ranges are from a few seconds up to 28 days as for the larger models.

Slownictwo Warsztatowe Anglijsko-Polskie

Under the above title the Association of Polish Engineers in Britain have published a useful booklet of workshop terms in Polish and English, intended for the use of Polish trainees and engineers in this country. It is excellently prepared with line drawings on each page and the terms set out clearly under each item. We are pleased to see that the draughtsman has followed

the example of this journal and used "Uno" stencils for the letterpress throughout. The address of the Polish Engineers Association is 18 Devonshire Street, W.1, London, and the price of the booklet is 3s.

Catalogues and Booklets Received

Messrs. Gardner's Radio, Christchurch, Hants.—Emergency catalogue covering their range of replacement transformers, chokes and condensers.

Their repair service includes rewinding speech coils, field coils and supplying and fitting new cone assemblies. Dealers and service engineers should write to the firm for full details.

Mallory Metallurgical Products.—Booklet on "Mallory 73" Beryllium-Copper alloy for contact springs, hair springs, diaphragms, etc. See November issue page 511.

Westinghouse Electric and Manufacturing Co., Pittsburg.—Beautifully produced and printed booklet on "Engineering Progress" for 1940, which covers all branches of Westinghouse activities from high vacuum C.R. tubes to automatic clothes-washers.

Bristol's Instrument Co., Ltd.—It should be noted that this company do not reside at Bristol, but was founded by Prof. W. H. Bristol of America in 1889. Bulletin E. 100 describes their "Pyromaster" potentiometer unit for recording "any physical property the variations of which can be measured as a function of e.m.f." Special models are available for use in pyrometers, tachometers, load meters, and ϕ H meters. An interesting device on which we hope to give a longer note shortly.

B.S. Specifications

The British Standards Institution has notified us that the following new specifications and amendments are now available:

B.S. 1007 for Non-ferrous Metals.—A comprehensive summary of British and American Specifications for all types of metals and alloys including 35 tables. Copies are 11s. post free from the B.S.I., 28 Victoria Street, S.W.1.

Memo. on Restriction of Steels.—The instructions from the M.o.S. are that all wrought and special alloy steels supplied shall be made to a selected list of 44 of the 58 steels given in this memo. (B.S.970 and 970A). Copies 9d. post free.

Amendment to B.S. 907-1940. Dial Gauges for Linear Measurement.—A standard has recently been issued for the shape of teeth in gear wheels for clockwork mechanisms. An amendment has been issued to B.S. 907 (Dial Gauges) which adopts the standard form of gear teeth given in B.S.978. Amendment gratis, B.S. 907 and 978 2s. 3d. each post free.

AMPLIFIERS
MICROPHONES
LOUDSPEAKERS
R · S Spells Quality

Just so long as there is R · S in Public Address Equipment so long will you be able to rest assured that not only is quality that intangible something that is usually associated with the term but that it is visible in the appearance, proven in the reliability and audible in the performance of every item we offer.

R · S

Amplifiers Limited

3-4, Highfield Rd., Shepperton, Middlesex
Telephone: Walton-on-Thames 1019

Not
Strained

The quality of a GARDNER Transformer, like that of mercy, is not strained. The many difficulties and exigencies that prevail to-day are brilliantly overcome by GARDNER design and engineering so that when you order Small Power Transformers up to 4 kva you do so confident in the knowledge that the best is the least you will get. Reminder! Please give priority numbers. Thanks.

QUALITY MAINS TRANSFORMERS

GARDNER'S RADIO, LIMITED,
SOMERFORD · CHRISTCHURCH · HANTS.

The Hewlett-Packard

A LELAND INSTRUMENT

Resistance-Tuned Oscillator

THE resistance tuned oscillator is recognised as a convenient and economical source of varying frequency and the Hewlett-Packard model shows how simple the controls and layout of this type of circuit can be made.

As the photograph shows, it is contained in a grey finished steel case with only three knobs for range, frequency and amplitude control. The circuit consists of a stabilised amplifier with regeneration supplied through a resistance-capacity network, the effective Q of which is increased by the amplifier so that stable oscillation is obtained.

A balancing circuit is also incorporated so that the oscillator is always maintained at its correct operating point and the distortion is kept at a low value. The frequency is tuned over a 10-1 range by means of a variable condenser and multiplied in steps of 10 by a resistance selector switch. It is claimed that the oscillator is fundamentally more stable and produces less distortion than the circuit normally used for audio frequency oscillators.

Specification :

Four standard models are available—Model 200A, 35 c.p.s. to 35 kc/s., Model 200B, 20 c.p.s. to 20 kc/s., Model 200C, 20 c.p.s. to 200 kc/s. and Model 200D, 7 c.p.s. to 70 kc/s.

Models A and B have transformer coupled output delivering 1 watt and Models C and D have R.-C. coupled outputs giving constant voltage over a wide frequency range.

The centre dial is calibrated directly in c.p.s., the range being selected by

the switch on the left of the centre dial.

Performance

Frequency drift less than 2 per cent. under normal temperature conditions.

Frequency change less than 2 per cent. for ± 20 per cent. line voltage variation.

Output: Models A and B: 1.0 watt into 500 ohms

Models C and D: 10 v. into 1,000 ohms load.

Frequency Response: Models A and

B: Output constant within ± 1 db. from 20 c.p.s. to 15 kc/s. Models C and D: Constant within ± 1 db. from 20 c.p.s. to 150 kc/s. and 7 c.p.s. to 70 kc/s. respectively.

Distortion: Total r.m.s. distortion within 1 per cent above 35 c.p.s. to 150 kc/s. in Model C. Model D has less than 1 per cent. distortion above 10 c.p.s.

The hum voltage is less than 0.1 per cent. of max. output voltage.

Valves: Models 200 A and B: 6J7—6F6—6F5—6V6—5Z4.
Models 200C and D: 2 6J7s—6F6—6V6—5Z4.

Dimensions: 16 in. long by 8 in. high by 9 in. deep. (Model 200D is slightly larger).

Weight: 32 lb. approx.

Calibration and Checking

The oscillator is carefully checked and adjusted before delivery, but for calibration the 50 c.p.s. point on the dial may be checked and the dial adjusted if necessary by slackening the setscrew in the flexible coupling. Ordinarily no further adjustment is necessary, but the tracking of the dial can also be corrected by a padding condenser located near the main tuning condenser. (See Fig. 2).

Supplies

All four models are obtainable for use on Government Service contract work and inquiries should be addressed to Messrs. Leland Instruments, Ltd., suppliers for this country, at 43a Mecklenburg Square, W.C.1.

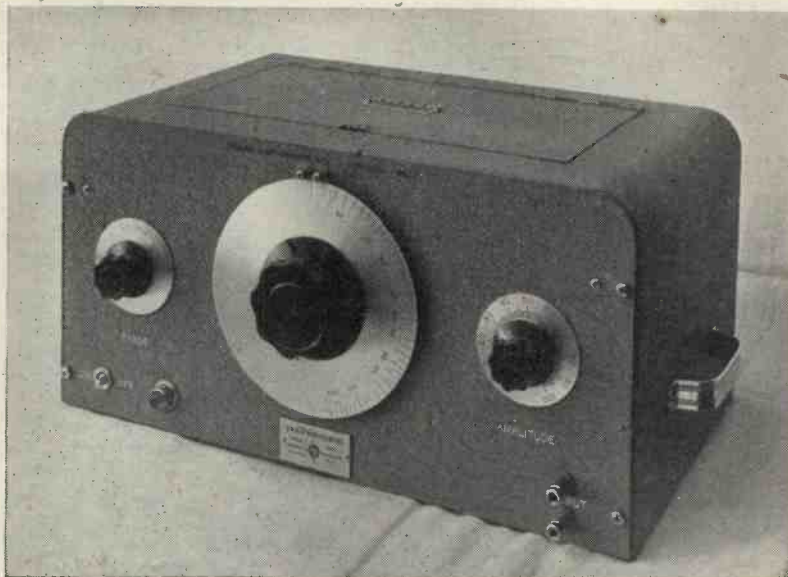

Fig. 1. Exterior view of Oscillator.

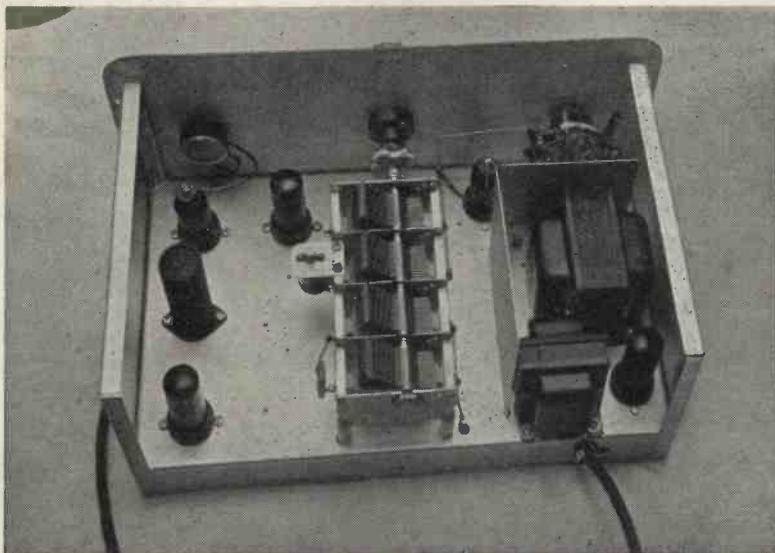

Fig. 2. Interior view showing simplicity of lay-out. The padding condenser for tracking is seen on the left of the tuning condenser.

TENAPLAS

EXTRUDED PLASTICS

The Tenaplas Method of Extruding Plastics ensures products of uniform quality and dimensional accuracy. Although at the present time Tenaplas Products are manufactured mainly for Electrical and Chemical Insulation there are many industries in which Tenaplas Extruded Plastics could be used with great advantage. Where technical excellence is of first importance Tenaplas can be recommended to fulfil every requirement.

TENAPLAS LTD, Head Office, 7 PARK LANE, LONDON, W.1.

CO-AX CABLES

FOR HIGH FREQUENCIES

Unequaled
in performance * range of characteristics *

*AIR-Insulated
and flexible*

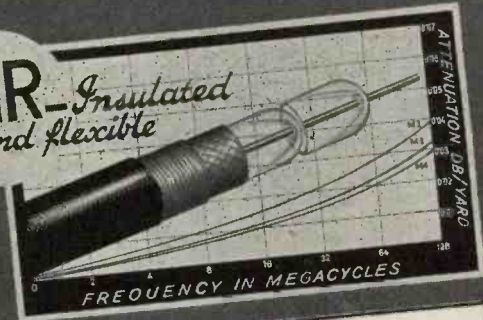

CO-AX Valve Connectors
Very low and constant capacity

TELEQUIPMENT CO.,

16, THE HIGHWAY, BEACONSFIELD, BUCKS.

HIVAC

THE SCIENTIFIC
VALVE

BRITISH

MADE



Specialists in
**MIDGET
VALVES**

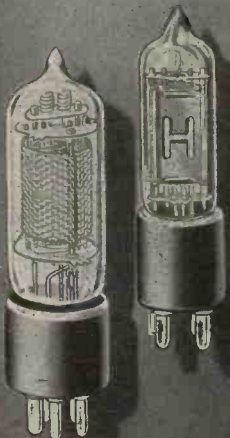

HIVAC LIMITED
Greenhill Crescent,
Harrow on the Hill, Middx.

Telephone: Harrow 0895.

ROLA

LOUD
SPEAKERS

THE WORLD'S FINEST REPRODUCERS

TRANSFORMER
LAMINATIONS

Core Widths $\frac{9}{16}$ " to $1\frac{1}{2}$ " (E's and I's.)

EIGHT STOCK SIZES

A Comprehensive Bulletin together with details of Associated Covers and Clamps with design data will be sent to manufacturers on request.

BRITISH ROLA LIMITED

MINERVA ROAD · PARK ROYAL · N.W.10 · WILlesden 4322

ABSTRACTS OF ELECTRONIC LITERATURE

TELEVISION & C. R. TUBES

Television—The Scanning Process (P. Mertz)

A descriptive study of the scanning process in television analysed in terms of a two-dimensional Fourier series of terms, which are correlated to the frequency components of the transmitted electrical signal.

—*Proc. I.R.E.*, Vol. 29, No. 10, p. 529.

A Versatile Oscilloscope (W. E. Gilson)

The original features in the unit described are the method of eliminating the influence of the amplifier control on the position of the spot in the direct coupled sweep circuit and the inclusion of a unity gain amplifier to avoid loading circuits under test. A beam intensifier circuit is also incorporated which can be used to eliminate the flyback or to produce timing marks. Provision is also made for single sweep operation.

—*Electronics*, Vol. 14, No. 12, p. 22.

Cathode-Ray Oscillograph (E. G. Downie)

The equipment and methods described are stated to have been developed to meet a need for a simple and effective means of photographing recurring or non-recurring waves viewed on the screen of a cathode-ray oscillograph. The apparatus consists of a metal camera (a lens of 50 mm. focal length, F1.4 aperture and 35 mm. film being used) either spring or synchronous-motor operated. The film speed is 13.6 ft. per second and the span of one cycle of a 60 cycle wave is 2.72 inches. The tube screen is held from the camera by a light-tight tapered metal shield. Although the motor provides a uniform time axis for film comparison a reference point for determining phase position is obtained by superimposing a small peaked voltage on the wave being studied. Typical oscillograms are compared.

—*EL. Engg. (Trans.)*, Nov., 1941, page 984.*

MEASUREMENT

Electronic Voltmeter (Penther, Rolfson, Lykken)

The electronic voltmeter described has been designed for measuring accurately potentials of electrode systems having a resistance of 5,000 megohms or less. It is stated to have a range of plus or minus 2.11 volts, and a sensitivity of plus or minus 0.001 volt over the entire range. It incorporates a potentiometer and valve circuit, the latter comprising a two-stage direct-coupled amplifier and filament resistor network. Details of operation procedure and characteristics conclude the article.

—*Ind & Engg. Ch. (AE)*, Nov., 1941, page 831.*

ELECTRO-MEDICAL

An R.F. Device for Detecting the Passage of a Bullet (C. I. Bradford)

An unusual application of radio engineering is described in which the reaction of a radio frequency oscillator to the presence of a metallic projectile in a link-coupled coil is utilised in connexion with projectile velocity measurements.

In order to obtain the accuracy of signal output required the circuits are designed for good transient response. In addition a unique method of differentiating clipping and amplifying is utilised in order to obtain a signal with steep wave front when the bullet is at the centre of the coil regardless of the weight, shape or velocity of the bullet.

Pictures are included of the equipment and coils used. High speed pictures of bullets in the tripping position in the coils and oscillograms of circuit voltages verify that circuit operation is as predicted.

—*Proc. I.R.E.*, Vol. 29, No. 11, page 578.

INDUSTRY

Automatic Winding

A machine is described for the winding of self-supporting insulated coils, such as those used in gramophone motors, no-volt coils, solenoids for switchgear control and audio-frequency transformers for use in the radio industry. Pedestal mounted, the winding spindle is driven by an electric motor at speeds up to 1,500 r.p.m. The mechanism of winding is dealt with in detail.

—*Electrician*, 3/3/42, page 263.*

Testing Radio Components (Coursey)

Three classes of test are studied, and a chart showing their respective relationships is given. Class 1 are electrical tests which can be covered by well-known standard test equipment. Fundamentally, these are all proof tests made on every component. Class 2 and 3 tests serve in the majority of cases as type tests applied to samples selected from a production batch. The former class includes normal or accelerated shelf, idling or load tests, and the latter group comprises climatic tests, *vis.*, temperature, humidity and pressure. Some details of climatic tests are given, steam injection and water evaporation methods compared, and recommended apparatus for carrying out such tests described.

—*Wireless Engg.*, Vol. 19, No. 222, page 96.

* Supplied by the courtesy of Metropolitan-Vickers Electric Co. Ltd., Trafford Park, Manchester.

CORRECTIONS

Frequency Measurement below 15 kc/s.

In the advance copy of the paper from which this abstract was taken an error in one of the circuit drawings was reproduced again in this journal. We are indebted to the authors for supplying a corrected drawing which is reproduced below.

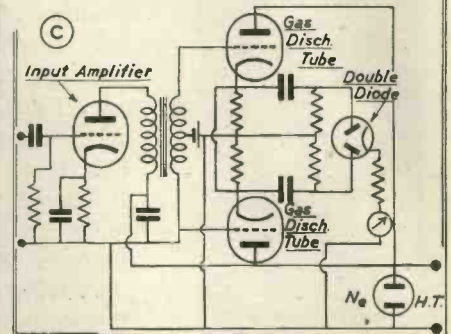

Differential Input Circuits

In the diagram of Matthews' differential input amplifier (p. 760, Fig. 2, May issue) the omission of a resistance in the earth lead of the input renders V_2 ineffective. This is shown in place in the diagram below.

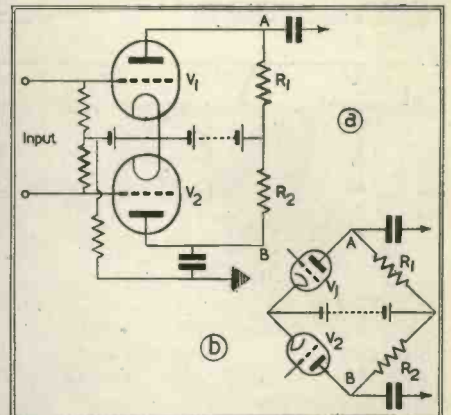

The circuit of Fig. 6b as originally drawn would, as one or two readers have pointed out, be hard on H.T. batteries!

Figs. 6b and 6c, giving equivalent of 'Tönies' input circuit, are reproduced in their corrected form:

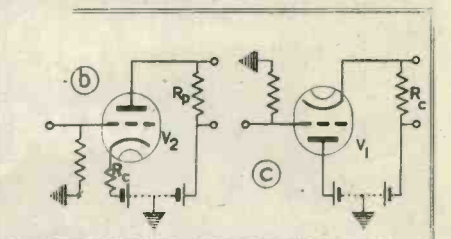

Our apologies to the author for marring his paper by these slips, for which he was in no way responsible.

Ode

Partridge No. 15

ECONOMISE

When we think of cars so comfy
As we sit on saddles bumpy,
We sort of come down earthwards
with a jerk.
But we can't restrain a chuckle
As our belts we tightly buckle,
And sally forth on cycles to our work.
Now it really does seem funny,
That altho' we've got the money,
We needs must trundle daily on two
wheels.
Still, it's no use turning crusty,
Even if our cars get rusty,
'Cos we've got to get our foes down
on their heels.
So pedal on and do your bit ;
It'll help the lads and keep you fit,
Whilst, *pro tem.*, motoring joys are
waived
Much "juice" and rubber will be saved.

N. Partridge

B.Sc., A.M.I.E.E.

Makers of Transformers and Chokes
King's Bldgs., Dean Stanley St.,
LONDON S.W.1

Telephone : VICToria 5035

TRIX

QUALITY
SOUND
EQUIPMENT

Designed and built for reliability and
high quality sound amplification



Let us send
you full
details

Amplifiers
4-400 Watts

Horns
Microphones
Loudspeakers

Equipment
available for
priority work,
factories, etc.

The
TRIX Electrical
Co., Ltd.

65 BOLSOVER ST.,
LONDON, W.1

Phone : EUSton 5471/2

Grams :
Trixadio, Wesdo, London

*This
year
.....?*

We manufacture low-loss ceramics pre-eminent in all fields of application. Our entire output being booked for months ahead, we are not, at the moment, able to accept further orders for the material. Perhaps later this year

LOW-LOSS
CERAMICS

by

TAYLOR
TUNNICLIFF
& CO., LTD.

Head Office : Eastwood, Hanley,
Staffs. London : 85, Streatham
Hill, S.W.2. Factories at Han-
ley, Stone and Longton, Staffs.
Telephone : Tulse Hill 5255-8
and Stoke-on-Trent 5272-4.

TEXTBOOKS

CATHODE RAY OSCILLOGRAPHS

By J. H. Reyner, B.Sc. (Hons.), A.C.G.I., etc.
Here is an easily understood guide to the
practical application of cathode ray tubes to
numerous purposes, including the examination
of oscillations or wave forms. Radio men, and
particularly those about to enter the services,
will find this book a genuine and invaluable
guide. It has been given the highest
recommendations both for students and
teachers. *Electrical Times* says: "Anyone
desiring a clear understanding of the Cathode
Ray Oscillograph . . . cannot do better than
purchase this moderately priced book."
8s. 6d. net.

MODERN RADIO COMMUNICATION

By J. H. Reyner. Every phase of current radio
theory is dealt with in this book. With its
clear and concise explanations, its helpful
illustrations and the careful arrangement of its
subject matter it is certain to give the greatest
possible assistance to students. Volumes I
and II together provide a complete groundwork
in Radio Engineering, and form an invaluable
textbook for all students and practical engineers.
Vol. I, 7s. 6d. net. Vol. II, 7s. 6d. net.

39, Parker St., Kingsway

PITMAN'S

FOR FREDDY

FOR DUTY

FOR RELIANCE

The famous "F for Freddy" in TARGET
FOR TONIGHT epitomizes for all time
the call to duty which proves reliance.

We have been proud of our duty for over
twenty years, in the manufacture of pro-
ducts on which our clients have placed
their reliance.

Today, National Requirements claim, and
are willingly given, priority of our duty,
but we are ever ready to give the benefit
of our long experience on variable
resistances—

You may have a problem—write and tell us.

RELIANCE

Manufacturing Co. (Southwark) Ltd.
Sutherland Road, Higham Hill,
Walthamstow. E. 17.

Telephone—Larkwood 3245

BOOK REVIEWS

Fundamentals of Vacuum Tubes

A. V. Eastman, 569 pp. 2nd. Edn. (McGraw Hill Co. 31/6 net.)

This edition of Professor Eastman's book has undergone considerable alteration and addition—so much so that it may be considered a new book. The author has rearranged the order of presentation so that the introductory part covers both the requirements of the industrial user of valves and those of the communications engineer. The first two chapters of Part 2 then deal with rectifiers and valves as control devices so that the industrial engineer may find most of the material he requires without going through the more theoretical aspects of the subject.

The very complete treatment of amplifier circuits which was a feature of the first edition has been expanded and includes r.f. power amplification. The chapter on Modulators now covers frequency and phase modulation and is a useful introduction to the theory of this development.

It is disappointing to note that the klystron and velocity modulated valves have only received cursory mention. It might be argued that these are too advanced for a book dealing with fundamentals, but a simple explanation of these devices is still lacking from modern textbooks and Prof. Eastman would be doing students a service by including them in his next edition.

Electric and Magnetic Fields

S. S. Attwood. 430 pp. 2nd. Edn. (Chapman and Hall. 27/- net.)

Advanced texts on electric and magnetic fields usually require a considerable knowledge of mathematics and do not provide sufficient practical illustrations of field distributions to enable the less advanced reader to obtain a grasp of the subject.

The reviewer has felt for some time that there was a need for a book which would bridge the gap between elementary and advanced textbooks for radio and electrical engineers with only a moderate knowledge of mathematics and Prof. Attwood's book fills this need admirably.

Its keynote is not to derive the laws and equations governing field problems, but to provide a sufficient number of illustrations of field distributions which an engineer might meet in actual practice. The number of drawings of both electric and magnetic fields of various geometrical forms is remarkable and the value they add to the text well justifies the amount of labour that must have been involved in their preparation.

The book is divided into four parts, the first giving the groundwork on the elements of electron theory, the second covering the magnetic field, the problems being treated for an

assumed constant permeability, and in the third part the ferro-magnetic field is further treated with varying permeability. The last part, which is perhaps less satisfactory on account of its brevity, deals with combined electric and magnetic fields. Some of the subjects of interest to communication engineers, e.g., skin effect and guided waves are less fully dealt with, but this may be due to the assumed limitations of the readers mathematical knowledge. Apart from this, the book is to be heartily recommended.

C.L.H.

Thermionic Valve Circuits

Emrys Williams, Ph.D., 170 pp. 106 Figs. (Pitman and Sons, 12/6 net.)

This book is based on a course given by the author to third-year students at the University of Durham and assumes a knowledge of A.C. theory and mathematics up to second year standard, although the main points are conveniently summarised in the opening chapter.

Apart from students, this book is of value to those electrical engineers who were trained before the valve reached its present stage of development, and it gives them the information they require for electronic engineering design work.

U.I.C.

—were first in the field and are still unsurpassed

Full details and advice gladly given.

UNITED INSULATOR CO. LTD.

12-20, LAYSTALL STREET, LONDON, E.C.1

'Phone : TERminus 7383

'Grams : CALANEL, SMITH, LONDON

CONTRACTORS TO G.P.O. & GOVERNMENT DEPARTMENTS
ON A.I.D. APPROVED LIST.

Ceramic Trimmer Condensers

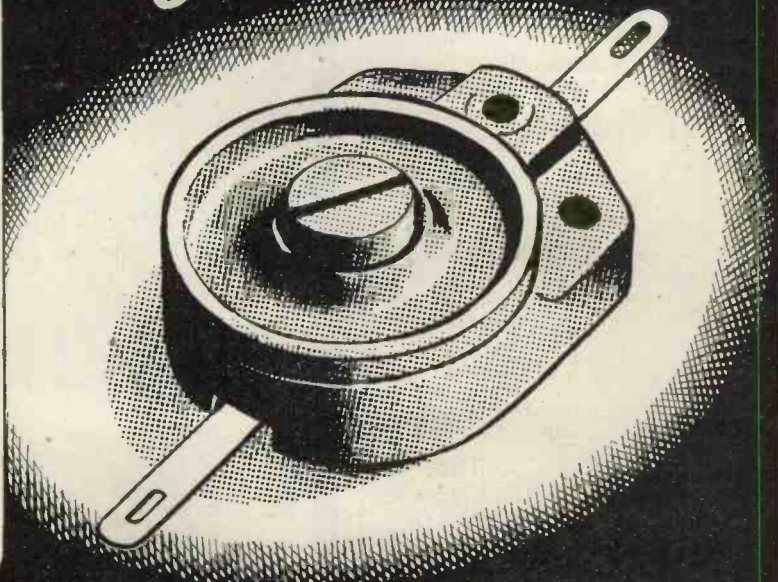

The Pioneers of Low Loss Ceramics



MINISTRY OF SUPPLY

BRITAIN URGENTLY NEEDS RUBBER

**Your worn-out CABLES, EBONITE, GLOVES, MATS, TYRES, TUBES
are wanted to help replace lost sources of supply — now!**

The enemy now holds 90% of the world's natural rubber resources. That is why every scrap of rubber lying useless and discarded all over the country is wanted for war purposes—at once! Organise a ruthless search — indoors and out — for waste rubber. Keep it up, week after week, until the war is won. Do more. See that from now on, you and everyone in your employ economise in the use of rubber; *that not a scrap is ever wasted, thrown away or burnt.*

CHECK OVER THIS LIST

Here is a number of important items made of rubber. Check them over when you are searching out your waste rubber for salvage.

ACCUMULATOR BOXES, LIDS,
SEPARATORS, TRAYS
ADHESIVE TAPE - BATTERIES
BATTERY CONTAINERS - BATTERY
BOXES, COVERS, LIDS & VENTS
BUFFERS - CABLE JOINTING STRIP
EBONITE FITTINGS & MOULDINGS
ELECTRICIANS' GLOVES
INSULATING BUSHES
INSULATING MATERIALS
INSULATING TAPE
INSULATED CABLE
INSULATED TOOLS
TYRES & TUBES

HOW TO HAND IN YOUR RUBBER

1 WORN-OUT TYRES & TUBES. Take them to a local garage for dispatch to an Official Government Depot; if unable to do so, put them out for collection by the Local Authority.

2 OTHER WASTE RUBBER. Put it out for collection by the Local Authority; or if you have a large amount for disposal you may sell it to a Merchant. If you don't know the nearest Merchant's address, write to **Rubber Control, (W.R.), Empire House, St. Martin's le Grand, London, E.C.1.**

3 If you accumulate more than one ton, you can arrange for a *special collection* by getting in touch with the nearest Demolition and Recovery Officer. If you don't know his address, write to **The Ministry of Works and Buildings, Lambeth Bridge House, Albert Embankment, London, S.E.1.**

SALVAGE IS OF SUCH VITAL IMPORTANCE that it should be made the personal responsibility of one particular individual in every organisation. Wherever possible, Industrial Salvage Stewards should be appointed and put in charge of an intensive and continuous drive for **STILL MORE SCRAP METAL, PAPER, KITCHEN WASTE, BONES, RAGS — AND RUBBER**

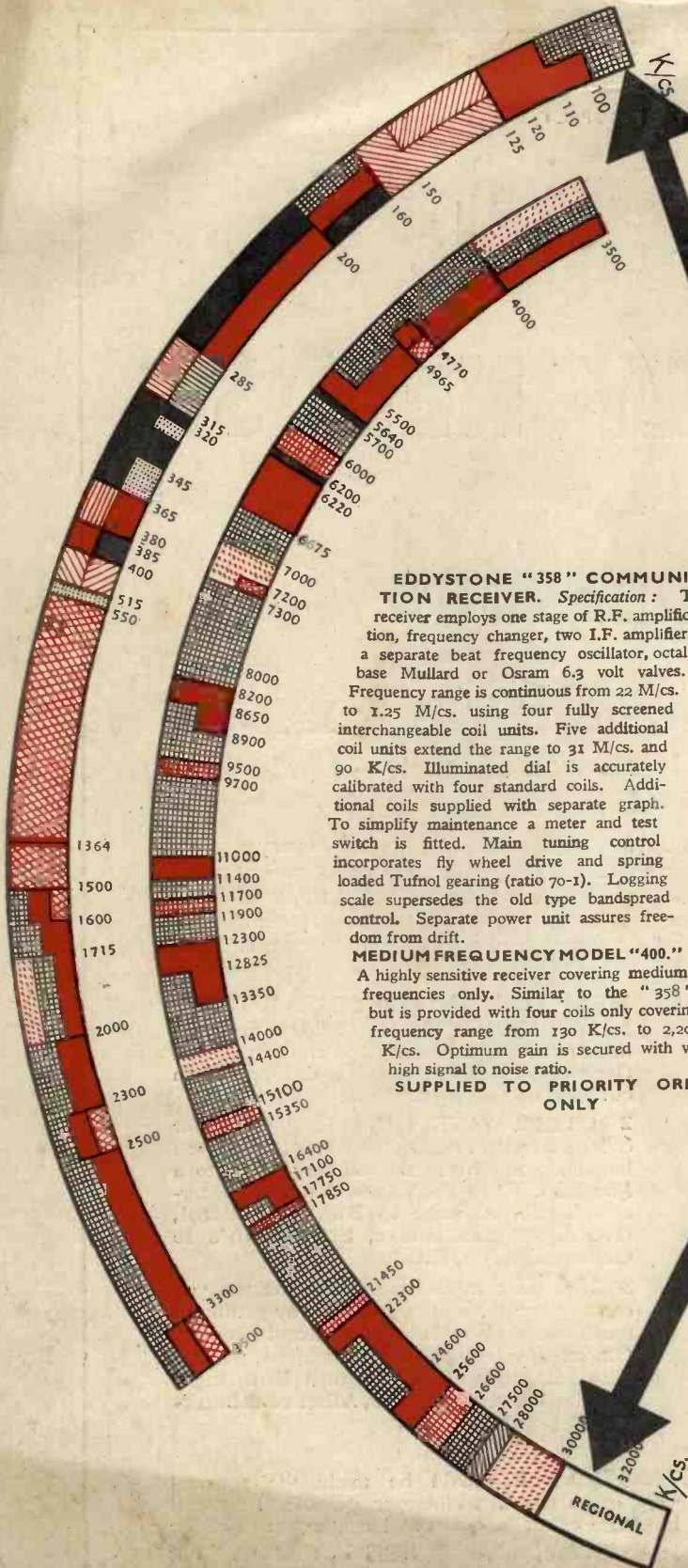

EDDYSTONE "358" COMMUNICATION RECEIVER. Specification: The receiver employs one stage of R.F. amplification, frequency changer, two I.F. amplifiers, a separate beat frequency oscillator, octal base Mullard or Osram 6.3 volt valves. Frequency range is continuous from 22 M/c.s. to 1.25 M/c.s. using four fully screened interchangeable coil units. Five additional coil units extend the range to 31 M/c.s. and 90 K/c.s. Illuminated dial is accurately calibrated with four standard coils. Additional coils supplied with separate graph. To simplify maintenance a meter and test switch is fitted. Main tuning control incorporates fly wheel drive and spring loaded Tufnol gearing (ratio 70-1). Logging scale supersedes the old type bandspread control. Separate power unit assures freedom from drift.

MEDIUM FREQUENCY MODEL "400."
A highly sensitive receiver covering medium frequencies only. Similar to the "358" but is provided with four coils only covering frequency range from 130 K/c.s. to 2,200 K/c.s. Optimum gain is secured with very high signal to noise ratio.

SUPPLIED TO PRIORITY ORDER ONLY



EDDYSTONE '358' Communication Receiver

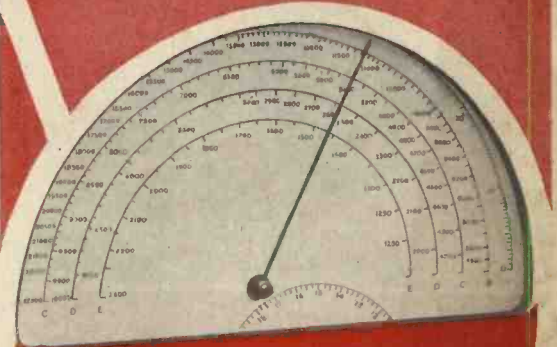

**WIDE
FREQUENCY
RANGE**

The frequency range of the Eddystone "358" Communication Receiver extends from 31 M/c.s. to 90 K/c.s. This coverage is graphically indicated in the diagram alongside which also shows the international allocation of wavebands to the numerous services which depend on Radio Communication. The Eddystone "358" thus affords a wide range of operating facilities combined with exceptional performance and reliability.

WEBB'S RADIO

THE SHORT-WAVE SPECIALISTS
14 SOHO STREET, LONDON, W.1.
Tel: GERrard 2089 Open 9 a.m. to 5 p.m. Sat. 9 a.m. / 2 noon.

- AERO-NAUTICAL
- FIXED
- AERO-RADIO BEACONS
- RADIO SOUNDING
- GOVERNMENT
- MARITIME MOBILE
- COASTAL MOBILE
- MARITIME RADIO BEACONS
- International Broadcast
- BROADCAST
- MARITIME DIRECTION FINDING
- AMATEUR
- MOBILE