

FIRST COMPLETE DETAILS MARCONI-E.M.I. SYSTEM

TELEVISION

THE FIRST TELEVISION JOURNAL IN THE WORLD

and

SHORT-WAVE WORLD

MONTHLY 1/-

MARCH, 1936

No. 97. Vol. ix.

BERNARD JONES PUBLICATIONS LTD.,
CHANSITOR HOUSE, CHANCERY LANE,
LONDON, W.C.2.

MORE ABOUT THE
NEW STATION

Dr. ZWORYKIN
on the
**ELECTRON
MULTIPLIER**

**HOW THE
CATHODE-RAY
MAKES THE
PICTURE**

**THREE
SHORT-WAVE
RECEIVERS**

Constructional Details

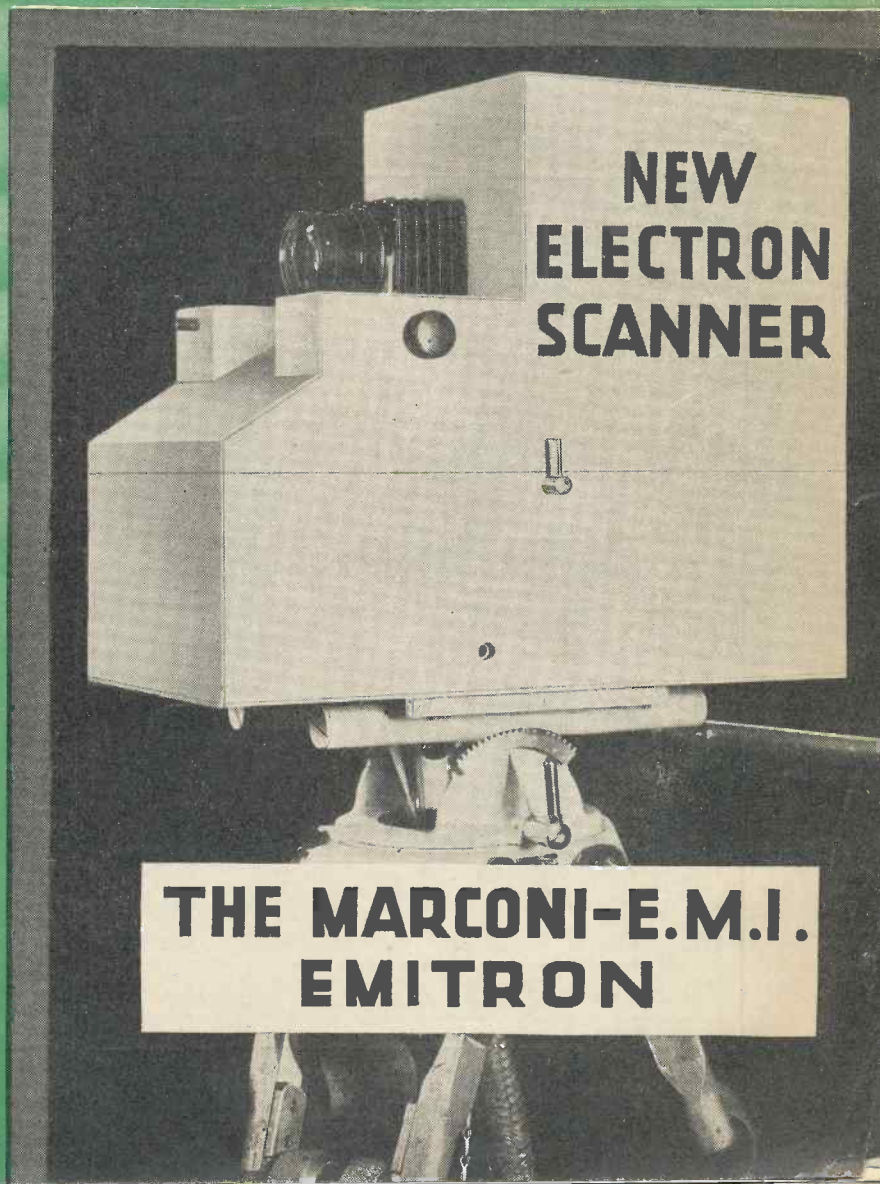
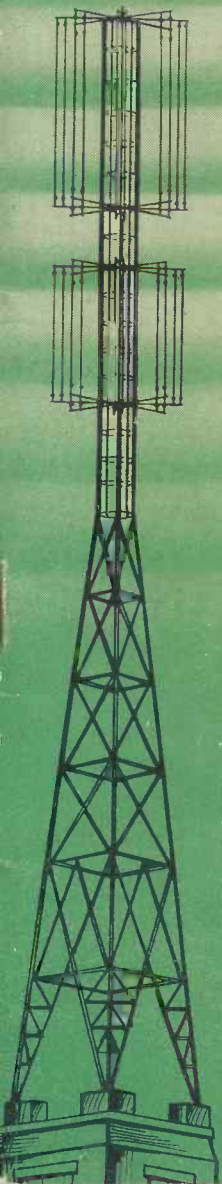

TELEVISION

and SHORT-WAVE WORLD

Special Features

	PAGE
The Marconi-E.M.I. Television System	132
Television Progress Abroad	137
How the Cathode-ray Makes the Picture	143
The Edison Cathode-ray Tube	144
Mechanical Film Transmission	143
New Type of Valve Coupling	148
Portable Battery Transceiver	149
Design of High-definition Amplifiers	151
Dr. Zworykin on Secondary Emission Multipliers	153
Principles and Practice of Electron Optics	155
Battery Short-wave Super-het	157
Uses of the Cathode-ray Tube	160
New Method of Interlaced Scanning	161
Pre-selector Unit	163
Automatic Grid Bias in Television Amplifiers	167
Recent Ultra-short Wave Developments	169
All-wave Coil Design	172
Transmission Line Loss Calculation	175
Simple Facts About Time Bases	177

COMMENT OF THE MONTH

Another Step Forward.

THE publication in this issue of the complete details of the Marconi-E.M.I. system marks another step towards the fulfilment of a service which has been awaited for the past twelve months. Progress may have seemed slow, but with the details of the B.B.C.'s elaborate plans and the very elaborate equipment of the Marconi-E.M.I. concern there can be no complaint that television is not being tackled in a thoroughly practical manner. As the photographs show the Marconi-E.M.I. gear is actually in being and complete in every detail and we believe the Baird Company is in the same position in regard to their apparatus. It is abundantly evident that all experimental work has been conducted and that the finished product is ready for installation at the Alexandra Palace.

The Public and Television.

IT is very evident that the general public, as represented by "the man-in-the-street," is most lamentably ignorant concerning television. On the whole there is a good deal of scepticism regarding the subject, which is hardly to be wondered at considering the conflicting matter that has been published and the anti-television campaign that has been conducted within the past twelve months. In the daily press television is practically taboo, or else there is the other extreme of wild statements which have no foundation in fact. Hardly any attempt has been made to educate the public as to what is possible and just what state of development the art has reached. Obviously the impression that has been created will not help matters at the start and we suggest that our readers will be doing television a service if they enlighten their less technical acquaintances on the subject and provide them with information that seemingly it is not possible for the average person to obtain elsewhere. All sorts of absurd misconceptions exist ranging from the idea that it will destroy all privacy, to the risk of extremely high voltages and that it will only be the plaything of the highly technical person. Then there is the too optimistic person who is under the impression that some little addition to the ordinary wireless set will enable him to receive the programmes, or again, that he will be able to have pictures which will occupy a considerable portion of one of the walls of an average sized room. There is in fact no end to the amazing ideas that are current and the sooner they are removed the better.

TELEVISION AND SHORT-WAVE WORLD

Proprietors :

BERNARD JONES PUBLICATIONS, LTD.

Editor-in-Chief :

BERNARD E. JONES.

Editor :

H. CORBISHLEY.

Editorial, Advertising and Publishing
Offices :

Chansitor House, 38, Chancery Lane,
London, W.C.2.

Telephones : Holborn 6158, 6159

Telegrams : Beejapee, Holb., London.

Subscription Rates : Post paid to any
part of the world—3 months, 3/6 ;
6 months, 6/9 ; 12 months, 13/6.

Published Monthly—1/- net.

(Last Wednesday in every month for
following month).

Contributions are invited and will be promptly considered. Correspondence should be addressed according to its nature, to the Editor, the Advertisement Manager, or the Publisher, "Television and Short-wave World," Chansitor House, Chancery Lane, London, W.C.2.

IMPORTANT

"Television and Short-wave World" is registered at the General Post Office, London, for transmission to Canada and Newfoundland by Magazine Post.

IT is common knowledge that for some years research in the principles of television has been conducted in the experimental laboratories of Marconi's Wireless Telegraph Co., Ltd., and of Electric & Musical Industries, Ltd. Both these organisations held the opinion from the commencement of their investigations that the many problems involved could only be solved by applying the scientific resources of well equipped research organisations, and also by treating the joint technique of the radio transmission and reception of television pictures as one fundamental and indivisible problem. Marconi's Wireless Telegraph Co., Ltd., in the radio communications field, and Electric & Musical Industries, Ltd., with their famous trade marks of His Master's Voice and Columbia, in the broadcast receiver field, enjoy world-wide repute.

THE FIRST COM OF MARCONI - E. M. I.

EMITRON SCANNING CAMERA ::
MODULATION :: THE RAD

*"Television and Short-wave World" is privileged to pub
to be used at the Alexandra Palace for*

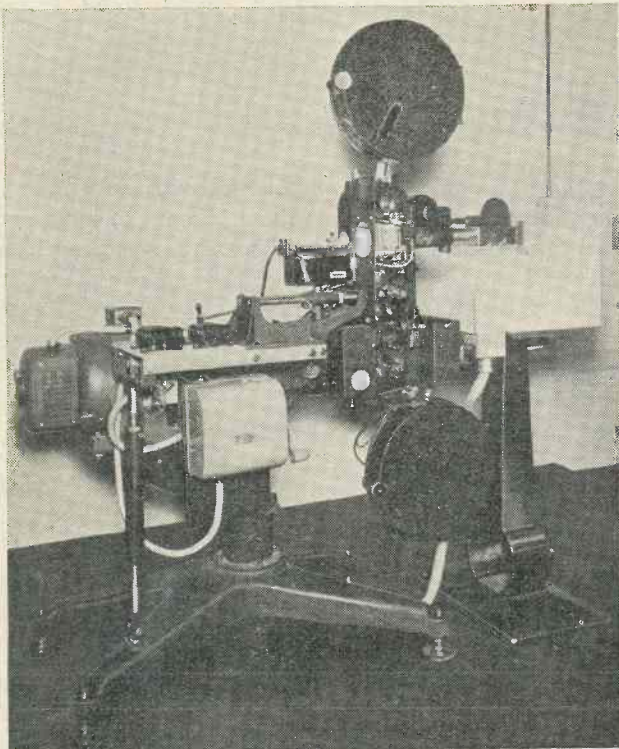

The film projector and scanning camera for televising film pictures.

The Marconi Company's unique experience of radio research and communications dates from the very beginnings of wireless and extends to every corner of the world, while Electric & Musical Industries, Ltd., possess one of the greatest vacuum and electron physics research organisations in Europe, coupled with many years' experience of sound recording and of the manufacture and distribution of sound reproducers and radio instruments for the domestic market. A joint concern was formed—The Marconi-E.M.I. Television Co., Ltd.—and this company has now produced a practical system of flickerless picture transmission and reception, which is the outcome of a close and sympathetic collaboration between the world's most advanced designers and constructors of wireless transmitting equipment and physicists and engineers.

Television presented a far more critical problem than any the art of radio communication has known before. The production and transmission of programmes for aural reception is a matter of considerably less techni-

cal complexity than is the case in the transmission of programmes which will be appreciated both by the ear and eye.

Features of Marconi-E.M.I. Television

The Marconi-E.M.I. television system embodies a complete equipment for the radio transmission of scenes enacted either in a studio or in the open air, as well as projection by the usual film process. Before describing the equipment in detail attention may be drawn to some of the outstanding features of the Marconi-E.M.I. television equipment.

Pictures of 25 per second with a detail of 405, 240 or 180 lines or intermediate values as required by local conditions can be transmitted at will. Straight or interlaced scanning is available. With interlaced scanning flicker is entirely eliminated. The method employed is simple and involves no additional controls or equipment at the receiver.

The "Emitron" television cameras have no moving parts, are noiseless, instantaneous and continuous in action, and can be used in any position. The "Emitron" cameras can be used under normal conditions of daylight on exterior locations or in studios.

Cameras can be used at large distances from the camera control equipment, which in turn may be connected to the radio transmitter by high-frequency cable or through a short-wave radio link.

Synchronism, i.e., picture steadiness with consistence of picture texture and shape, is under all circum-

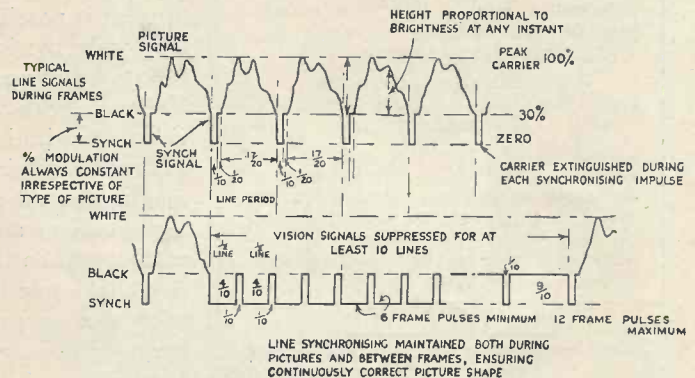

Diagram showing the type of waveform to be used for the Marconi-E.M.I. television system.

COMPLETE DETAILS OF THE TELEVISION SYSTEM

CONTROL AND SCANNING EQUIPMENT
AND RADIO TRANSMITTER AND AERIAL

publish the first complete details of the Marconi-E.M.I. system
for the new high-definition transmissions.

stances "absolute" and is entirely independent of any variations of the main supplies. With the system employed the greatest economy and simplicity of receiver design and operation is secured.

The "D.C." system of modulation and synchronisation employed transmits changes in values of picture tone, e.g., from a sky scene to a dark interior instantaneously, irrespective of how long any one particular type of scene has been maintained, without the necessity of readjustment of the transmitter or receiver.

The circuits throughout provide a substantially flat response curve over a frequency band of approximately ± 2 megacycles.

While the use of a particular type of waveform is advised (see page 132), the system can be adjusted at will to transmit waveforms of other types if desired. The equipment is designed to operate on fixed wavelength selected within the ultra-short waveband of 3 to 8 metres (100,000-37,500 kcs.).

The high-frequency amplifying circuits of the transmitter are "driven" by a specially designed type of valve master oscillator which maintains the radiated frequency to within ± 1 in 20,000 irrespective of normal variation of supply voltages and temperature.

Pictures from a number of cameras can be arranged in any desired sequence or combination of studio, exterior or film scenes, ensuring that essential continuity of programme common to sound broadcasting, as distinct from film production methods.

Monitoring arrangements are available for the vision director to look at any set or location which is due for subsequent presentation without disturbing the transmission in progress. Rehearsal and production conditions are catered for, in addition to the necessary picture and sound mixing devices, by the supply of adequate intercommunication speech channels centralising at the programme control desk.

The control of the transmitter is effected from a separate transmitting engineer's control desk, on which is mounted the necessary equipment for maintaining normal transmission conditions.

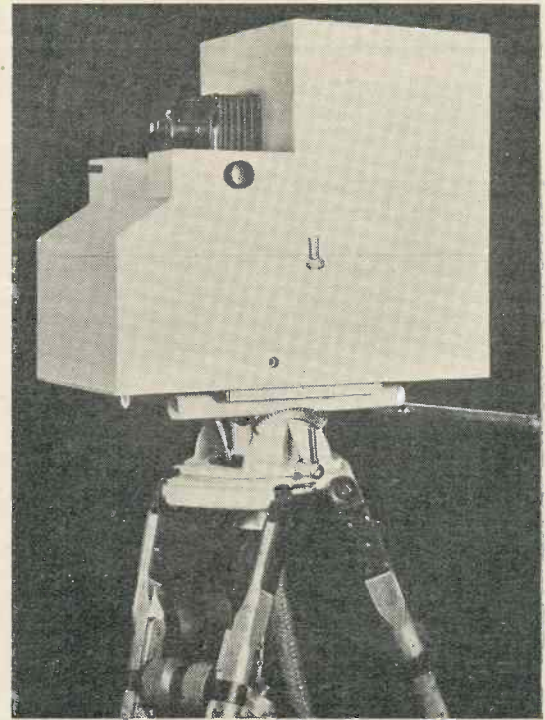

The Emitron scanning camera mounted on a studio tripod.

Description of the Equipment

The Marconi-E.M.I. television transmitting equipment may, for the purpose of this description, be divided as follows:—

- (1) The Emitron television cameras.
- (2) Camera control and scanning equipment.
- (3) Modulation amplifiers.
- (4) Constant-frequency master oscillator.
- (5) Frequency doubler.
- (6) Five stages of carrier-frequency amplification.
- (7) Single stage modulated carrier-frequency amplifier.
- (8) Aerial system.

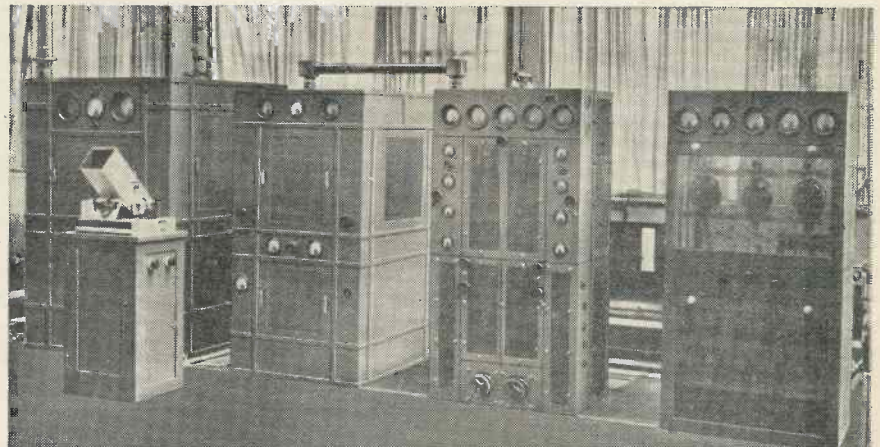

The Marconi-E.M.I. ultra-short wave radio transmitter gear.

THE MARCONI-E.M.I. CONTROL SYSTEM

Camera Equipment

The camera equipment includes four Emitron instantaneous scanning cameras and their associated apparatus for studios and outside broadcasting, and two Emitron film scanning cameras with associated film projectors and re-wind units for transmission of film pictures. The scenes to be transmitted are directly and continuously transformed by the cameras into electrical im-

3. Generates and applies the necessary synchronising pulses, in any form desired, to the picture signals for the modulation of the radio transmitter.
4. Provides means for visually inspecting and adjusting any camera picture or electrical impulse either as it passes to the transmitter or from individual cameras.
5. Superimposes or fades camera pictures from one to another whether from film, studio or outside locations.

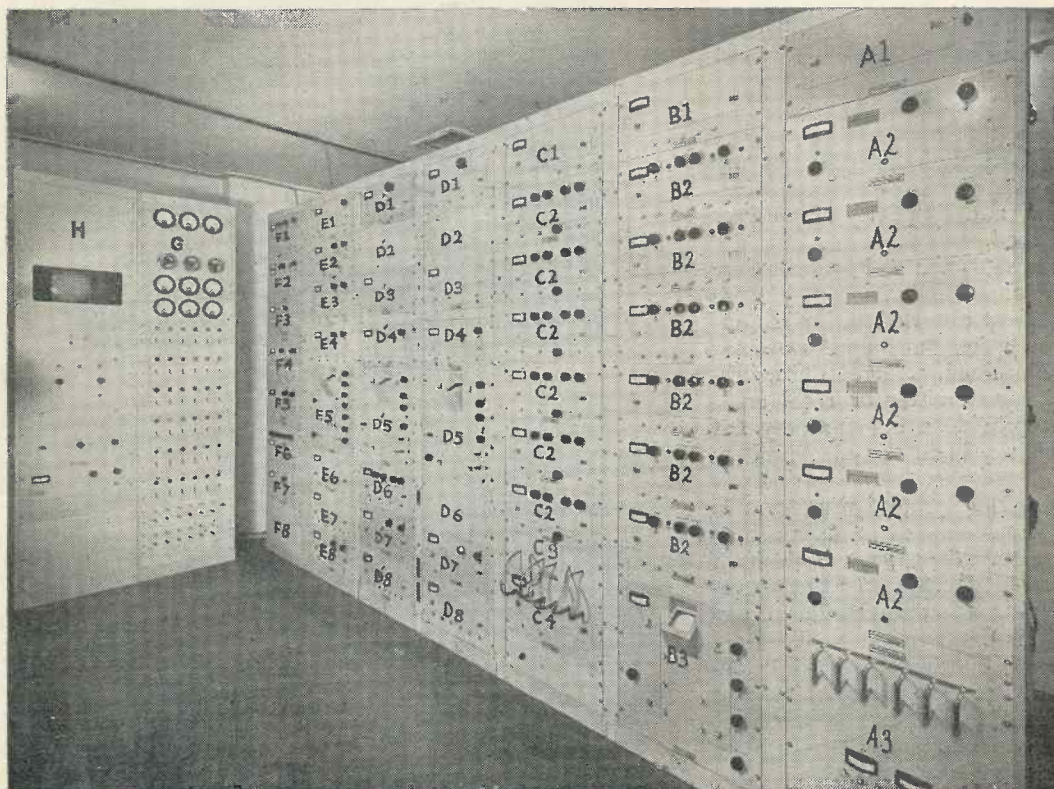

This is the Marconi-E.M.I. camera control and scanning equipment of which full details are given in the text.

pulses. The cameras are fitted with 6.5 in. F/3 lenses normally focused at the camera itself.

The cameras are connected to the camera control and scanning rack by a special design of multi-core cable fitted with male and female junction units.

Camera Control and Scanning Equipment

The camera control and scanning equipment consists of eight racks, each 24 ins. (61 cms.) wide by 7 ft. 5 ins. (2.3 metres) high, mounted together to form one complete bay. The equipment is complete with all the necessary signal and impulse observation tubes, calibration gear and remote controlled supply equipment. The camera control and scanning equipment is shown above.

The camera control equipment:—

1. Provides all operating electrical supplies and scanning pulses to the Emitron television cameras.
2. Amplifies and distributes the vision signals generated by the Emitron cameras.

The camera focus rack (A above), supplies to the six camera channels the necessary electrical focus potentials for controlling and biasing the scanning beam. These potentials are generated in the camera high-tension unit (A1) at the top of the rack. The necessary adjustment for each camera is provided in a series of six units (A2), below which is the junction unit (A3) for supplying the outgoing potentials to the cameras and collecting back the picture signals before passing them to subsequent racks of the camera control equipment.

The camera scanning rack (marked B) generates and distributes the saw-tooth potentials necessary for maintaining correct scanning conditions at the cameras. The actual saw-tooth potentials are generated at unit (B3) and distributed to the cameras *via* the units (B2) and the junction unit (A3) mounted in rack (A).

The rack, marked (C) is the "A" amplifier and fader which receives the incoming picture signals from the six camera channels and amplifies each camera output by means of units (C2) any of which can be connected into circuit by means of the plug board (C3). The pic-

THE MARCONI-E.M.I. METHOD OF MODULATION

ture signals from the amplifiers (C₂) are then passed into a common amplifier (C₄), in which arrangements are made for fading or superimposing any of the six camera outputs by direct controls mounted on the rack itself or by means of remote controls mounted on the vision director's desk.

Unit (C₁) is for the purpose of reversing the picture from a "negative" to a "positive" for monitoring purposes.

The rack marked (D) is the "B" amplifier picture rack, and this enables further amplification of the selected vision programme to be effected by means of unit (D₁), the picture detail being controlled by unit (D₂) and further amplified by unit (D₃) which also serves, together with unit (D₄), to remove any spurious signal content which may be present. Picture contrast is adjusted by unit (D₆), the finally adjusted and corrected picture signals being observed in the picture monitor tube mounted in unit (D₅).

Unit (D₇) injects the necessary picture synchronising impulses into the picture signals; the complete transmitter modulating signal, i.e., picture signal and synchronising impulses, passing through the amplifier unit (D₈), from which emerge six separate channels, two of which (one spare) are taken to the transmitter modulators *via* a line frequency corrector and amplifier; the other four channels are available for monitor picture receivers located at required points. Such a monitor picture receiver is shown mounted on rack (H).

The monitor rack, which is marked (D₁), is a replica of the picture bay and may be used as a stand-by equipment for that rack. The rack is equipped for the observation of the signals from any particular camera channel, the necessary contacts being made to the "monitor rack" by means of a plug unit (C₃) of the "A" amplifier and fader rack.

The picture tube on the monitor rack allows observation of the picture signals on any of the six camera channels, and, in addition, supplies additional picture plus synchronising impulses for further picture monitoring apparatus which may be desired, in addition to those provided for by the channels available from the "B" amplifying picture rack.

The oscillator rack, marked (F), incorporates the master oscillators for maintaining the line and picture synchronising impulses at their correct frequencies.

Unit (F₁) is an oscillator driven from the local supply mains. This oscillator drives a controlled oscillator unit (F₂), which, in turn, drives a master oscillator (unit F₃) at a constant frequency.

Unit (F₄) is a stand-by master oscillator similar to unit (F₃) but independent of the mains supply.

Unit (F₅) divides the frequency of the master oscillator (F₃) by a suitable factor for controlling the line synchronising impulses actually generated and distributed by the impulse generator rack (E).

Unit (F₆) divides the frequency of the master oscillator by a suitable factor for controlling the picture synchronising impulses actually generated and distributed by the impulse generator rack (E).

The rack marked (E) is the impulse generator rack, and it effects by means of units E₁, E₂ and E₃ the actual generation and distribution of the impulses for line-frequency synchronising and picture-frequency syn-

chronising. These impulses are of geometrically perfect waveform and are superimposed, as mentioned before, on the picture signals in unit (D₇) of the "B" amplifier picture rack.

Unit (E₅) incorporates a cathode-ray tube for observing the waveform of the outgoing oscillations; units (E₆) and (E₇) generate saw-tooth impulses at the line and frame frequencies respectively. These impulses are injected into the camera signals in the "A" amplifier rack for the purpose of adjusting the evenness of illumination of the televised image.

Unit (E₈) supplies recurrent "black out" signals to the cameras *via* the focusing rack in order to prevent the return movement of the camera scanning beam at the end of each line scan and at the end of each picture scan being seen on the received picture.

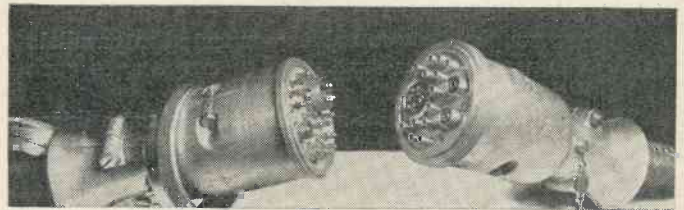

Special junction unit for connecting multi-core cable between the cameras and the control equipment. The cable used is capable of passing a frequency band of 3 megacycles without appreciable distortion.

The rack, marked (G), provides the necessary high- and low-tension potentials, both A.C. and D.C., for the operation of the camera control and scanning racks. Isolating switches and their associated meters are fitted for each section of the equipment, and the necessary rotary generators and motors which supply current to the racks are operated by remote push-button controls fitted to the supply rack (G).

Constructional

Features

All the panel units are fitted with locking controls so that alterations to adjustments cannot be made without first unlocking the controls, and each unit assembly is in the form of a removable panel which can be withdrawn from the rack, if necessary. All valves are easily accessible by the removal of cover plates held in position on the fronts of the units by spring clips.

A milliammeter mounted on each unit, where necessary, enables the anode current of each valve to be measured, the instrument being connected to any desired circuit by means of push-button switches.

The combined picture signal and synchronising impulses from unit (D₈) on the "B" amplifier rack are taken to a line corrector and amplifier before applying them to the modulating system. Irregularities of the frequency characteristic caused by the length of cable between the camera scanning equipment and the modulating system are here corrected.

D.C. System

of Modulation

The method of modulation employed is that known as the Marconi-E.M.I. "D.C." system, whereby a

MARCONI-E.M.I. RADIO TRANSMITTER

direct current is introduced into the modulating circuits by a "black level" circuit. This method ensures that the relationship between the picture brightness and the carrier current is correct from instant to instant, without the need of adjustment of any kind at the receiver. In addition, zero carrier at each synchronising impulse ensures that the effect of interference on the synchronisation of a receiver is reduced to a minimum.

The percentages of carrier amplitude allocated to the picture and synchronising impulses are maintained at a constant predetermined value whatever type of scene is being transmitted, and irrespective of how much the scene changes in light values.

The modulator comprises six stages of amplification, namely:—

- (1) A sub-modulator consisting of a single valve stage coupled to two valves connected in parallel;
- (2) A sub-modulator stage consisting of a single valve stage coupled to two valves connected in parallel;
- (3) A main modulator consisting of two stages each utilising cooled anode valves.

The modulating circuits are designed to have linear response from zero frequency (D.C.) to 3 megacycles.

The Transmitter

The radio transmitter consists essentially of a master oscillator, frequency doubler, five stages of carrier frequency amplification and a single stage modulated amplifier, with the addition of the necessary rectifiers for the main high-tension and grid-negative supplies.

The component parts of the high-frequency circuits are mounted in brass frameworks, and those of the rectifying circuits in iron frameworks. Tuning adjustments, circuit controls and indicating instruments are mounted on the fronts of the units and are within easy reach and view of the operator. The component parts subjected to high-frequency currents and high voltages are insulated by means of mycalex and porcelain, thus providing a high factor of electrical and mechanical safety.

The Master Oscillator.—A valve circuit of special design ensures constant frequency irrespective of any change in filament voltage, anode supply voltage or of temperature that are likely to occur. The current frequency is maintained to an accuracy of the order of ± 1 in 20,000 when the anode supply or filament voltage do not vary more than ± 5 per cent.

H.F. Amplifiers.—The master oscillator is followed by a frequency doubling stage, five stages of amplification at the carrier frequency and then by a single stage acting as an amplifier of modulated high frequency oscillations. Each amplifying stage consists of a valve or valves connected in a balanced bridge circuit, together with a closed oscillatory tuning circuit, each of which includes an inductance and variable air condenser controlled from the front of the transmitter. The first stage employs two glass envelope valves; the second stage two air-cooled valves; the third stage one air-cooled valve; the fourth stage two air-cooled valves. The fifth and sixth stages employ two water-cooled valves designed specially for operating on very short wavelengths.

The fifth and sixth stage amplifiers are mounted in separate units coupling between these two stages and also between the fourth and fifth stages being by means of adjustable inductance-capacity circuits connected through concentric tube feeders.

Low-loss Anode Cooling System.—The anode tuning inductance in each of the fifth and sixth stages forms an integral part of the valve cooling system, the cooling water circulating through the inductance, from which it is led out to rubber high-tension isolating spirals at the electrical centre of the circuit in order to avoid high-frequency dielectric loss in the water. The output circuit of the sixth stage is designed for coupling to a Marconi concentric tube feeder, having a characteristic impedance of 75 ohms. Provision is made in this stage for coupling to the outgoing feeder an external cathode-ray oscillograph mounted in the control desk. This enables a comparative visual check to be made between the incoming line signals and the output signals of the transmitter and any adjustments of the circuits can be carried out during transmission.

Rectifiers

The main power rectifier units, two in number, are arranged for full-wave rectification. They are similar in design and differ only in the size of valve used and the output. One of the units, incorporating six mercury-vapour rectifying valves, is used for providing high-tension direct current for the anode circuits of the sixth stage or final amplifier. The second unit, incorporating six mercury-vapour rectifying valves, is used for providing high-tension direct current for the anode circuits of the third, fourth and fifth stages of high frequency amplification. Provision is also made in each rectifier unit for "conditioning" two spare valves, so that they are ready for service when required.

The rectifier filaments are heated from the main alternating current supply, and special starting rheostats are provided, in which motor-operated contactors bring the filaments to the working temperature in delayed steps. When the full filament voltage has been applied, auxiliary contacts on the rheostat allow of the application of the anode supply at a reduced voltage. The main power can then only be brought up to the full working voltage after a further controlled delayed period, when the proper vaporisation temperature of the mercury has been reached. The power input to each of the main rectifiers can be controlled from full power down to quarter power by means of separate motor-controlled induction regulators.

The auxiliary rectifier units, two in number, incorporate metal-oxide rectifiers, each of which is provided with its own smoothing system and supply transformer. Potentiometers or resistances connected in each rectifier output circuit allow the voltages to the various circuits to be adjusted to the required values. The first of these two rectifier units provides for the supply of anode current to the master oscillator, doubler and first amplifier, and to the second amplifier, and, in addition, filament current to the master oscillator, doubler and first amplifier, and grid negative bias to the master oscillator, doubler and first four stages of amplification.

(Continued on page 192.)

TELEVISION PROGRESS ABROAD

This article is a brief resumé of television activities on the continent and in America. Practically every country is now devoting

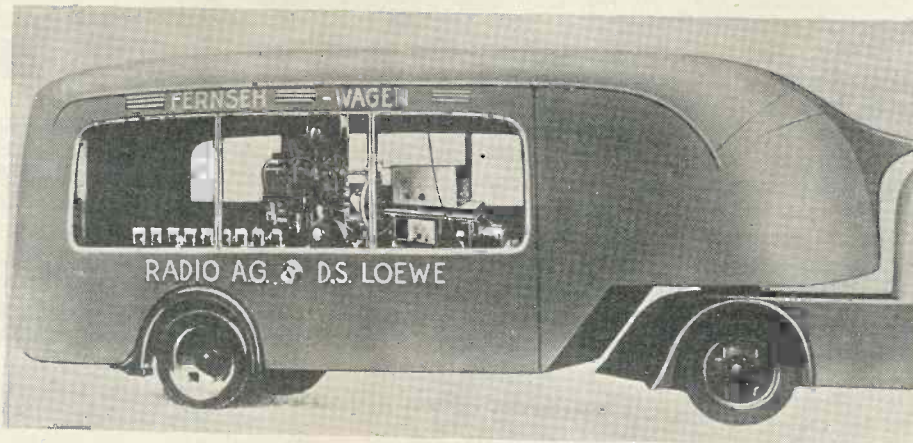

serious attention to television and in many cases the governments are taking an active part in research work.

A German mobile television transmitter.

THE fact that with the possible exception of Germany all television activities are more or less experimental makes it exceedingly difficult to obtain any precise information regarding the progress being made. Even in our own country where a public television service is well on the way to fulfilment, the various concerns are not any too eager to disclose either their methods or the precise amount of progress made. Then again reports are constantly coming to hand of work of private individuals but without any definite proof of the claims that are made.

It is difficult even to make any comparison between the countries which are leading in the television race. Germany, for instance, has really got down to the practical side of the business and yet America is the pioneer of electronic scanning, and the work in this direction that has been done there gives that country a leading position although television has not yet entered into the practical stage.

The foreign countries which are known to be really active are America, Germany, France, and Russia, and to a lesser degree Italy, Sweden and Japan. There is also a certain amount of activity in the Colonies.

Television in America presents a difficult problem on account of the large areas that will have to be covered and it appears that the trouble is largely financial. Abortive attempts were made some four or five years ago to popularise low-definition television and several stations

put out transmissions, but they only managed to interest a small number of experimenters, and when it was realised that there was no financial gain possible the transmissions were dropped.

This set back, if it can be termed such, did not deter the really serious workers from continuing their research and two outstanding names are now before the television-minded public of the whole world—Farnsworth and Zworykin. The latter is the sponsor of the Iconoscope and responsible for recent developments of the electron-multiplier; he occupies an official position with the Radio Corporation of America.

America

In May, 1935, the Radio Corporation of America decided that the time had come when television should be taken out of the laboratory, and announced its intention of spending £200,000 on development. The programme decided upon comes under three headings:

(i) The construction of the first modern television plant in the United States.

(ii) The manufacture of a limited number of television sets to be placed at strategic places.

(iii) The development of a programme service with the necessary

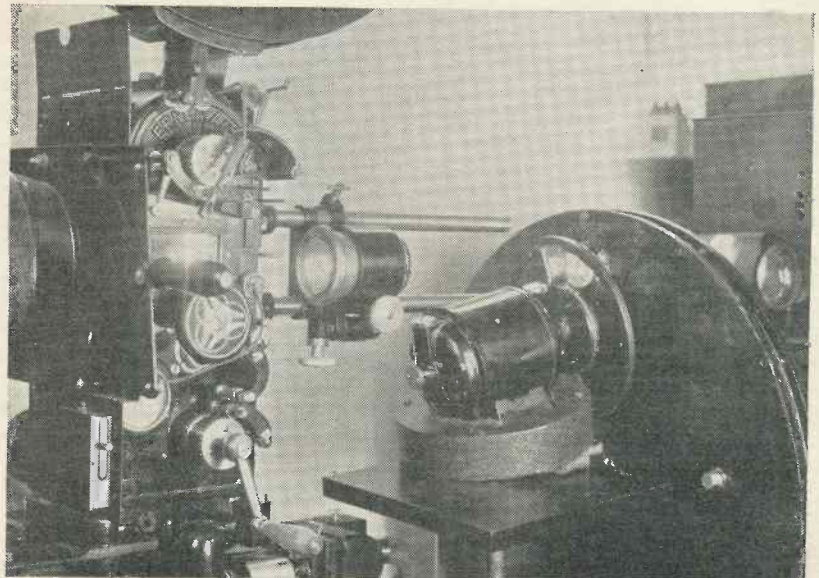

TeKaDe transmitter for interlaced scanning.

TELEVISION ON THE CONTINENT

studio technique to determine the most acceptable form of television programmes.

The experiments are expected to take at least 15 months, and the New York headquarters will probably be the 100th floor of the Empire State Building, where an experimental transmitter has already been in use for several years past. Visual programmes will at first only be available in thickly-populated cities, where a single transmitter erected on some high point can serve a comparatively large number of "lookers." Ultra-short waves will be used in the tests, with an expected range of 25 miles.



Fernseh cathode ray home receiver.

Another very active concern in the United States is the Farnsworth Television Corporation, and it is generally thought that this company will be transmitting a regular schedule of programmes before transmissions are commenced by the R.C.A. There are numerous reports of other television activities, but the fact that the Federal Communications Committee has asked the Farnsworth Company and the Radio Corporation of America to settle such details as the line and picture frequencies, indicates that it is these two concerns that are really in the running. Philo. T. Farnsworth is responsible for the image camera which is to be used by the Baird Company in this country.

Germany

At the German Radio Exhibition in August, 1935, no less than twenty

television receivers were exhibited operating from the Berlin 180-line twenty-five pictures per second transmissions, and it was proposed to carry on with a regular service of programmes. This scheme, however, was interrupted by a disastrous fire which broke out and destroyed the greater part of the apparatus.

The German Post-Office, which is taking a very active interest in television, decided, however, to take up high-power ultra-short-wave television broadcasting at the earliest possible moment again and gave orders to Telefunken to supply twin transmitters similar to those which were destroyed by the fire, with the

least possible delay. As it would have taken some months before suitable transmitters for 240 lines and 25 frames per second could be ready the Post-Office and Telefunken decided to limit the new outfit to 180 lines and 25 frames. Work on these transmitters has been completed and they have been installed in a temporary

transmitter building situated at the foot of the Witzeleben radio tower.

Programmes are supplied by the German Broadcasting Company and mostly consist of films or scenes taken by the help of the intermediate film reporters' van. Vision is broadcast on 6.722 metres and sound on 7.053 metres.

For the present the Witzeleben transmissions are regarded as educational and it is not proposed to make receivers available to the ordinary public for the time being in view of the possibility of technical improvements in the near future. It seems

likely that the standard of definition will be raised very shortly for it is known that a good deal of work is being done with electronic scanning. Facilities are offered to the public to witness the programmes by the opening of eleven viewing rooms in different parts of Berlin. Broadcasts take place daily from 8 p.m. to 9 p.m. and are repeated from 9 p.m. to 10 p.m. To accustom Berlin listeners to ultra-short-wave broadcasting ordinary sound programmes relayed from the Deutschlandsender are broadcast daily from 5 p.m. to 7.30 p.m. and from 10 p.m. to midnight (Berlin local time).

France

France displayed very little interest in television until about April last year when a series of 60-line transmissions were inaugurated from PTT. It was announced at the time that these were only experimental and that it was proposed to gradually increase the definition. The picture frequency was 25 per second with a ratio of 3-4 on a wavelength of 175 metres. A decision, however, was quickly reached to increase the definition to 180 lines, and as a result the station was formally opened on November 17 working on 180 lines and 25 pictures per second. The studio is in the PTT building, rue de Grenelle, and the aerial is erected on the Eiffel Tower. Full details of this station were given in our January issue.

Russia

In Russia television is also making progress. The Radio Committee will have three special television transmitters erected during 1936; these will be situated respectively in Moscow, Kiev and Leningrad. A transportable transmitter is also being constructed for direct transmission. Apart from these stations, other television transmitters are also proposed for distant centres such as Khabarovsk, Nevosibirsk, Tachkent, etc.

Japan

The Japanese are taking a very keen interest in television though from reports received nothing more ambitious than sixty lines has been tackled. An experimental service is to be started this year with the object of determining the best system and studying the subject generally. This station is to be erected in Tokyo.

Read

**Television and
Short-Wave World**

Regularly

PROGRESS AT ALEXANDRA PALACE

Readers will remember that in our November, 1935 issue we published the first description of the Alexandra Palace as it will be when the necessary alterations are complete. The details then given were exclusive to TELEVISION and Short-Wave World. By courtesy of the Editor of the Hornsey Journal we are now able to give some further information which has been furnished by Mr. L. R. Charlwood, the Clerk of the Works, and was exclusively published in that paper.

So far as constructional alterations of the Alexandra Palace are concerned, the work is now practically complete. No longer is there any connection between the portion to be used as London's first television station and the remainder of the Palace. Corridors and stairways that formerly led into the main building have been bricked up and a new entrance made under the south side of the tower.

Through imposing doors, probably of copper, the visitor will pass into a specious entrance hall of 33 feet by 20 feet. To his right front is an inquiry office. Straight ahead is the main staircase leading to the first floor, on which the studios are situated. The tower itself has been completely altered. Inside this steel girders have been erected to take the weight of the five floors inside the tower and of the 30-ton aerial mast.

Inside the tower the visitor will notice an alteration. Between the ground and first floors a mezzanine floor has been introduced, and this procedure has also been adopted between the first and second and third floors. Here there will be 26 offices. These will house the executive, and inside them the visitor's attention will be caught by the pleasant cantilever bay windows on the south and east elevations.

Artists' Rooms

From the second floor a long corridor branches off towards the south end of the building. To the left of the corridor are the two studios, which command a pleasant view over Hornsey and Wood Green, and to the right the offices and cloakrooms for the artists. First on the right comes the gentlemen's dressing-rooms and bathroom. Further down on the right are four ladies' dressing-rooms and the ladies' bathroom. The next door along the passage opens into an artistes' waiting-room, which gives

into a 5 feet by 16 feet boudoir specially built for the lady announcer.

Beyond that, at the far end of the corridor, is the band rehearsal room, situated over the old Palace kitchens. To deaden the sound the walls of this room are being treated with special boarding and with slag wool.

At the end of the corridor is a staircase for staff use, leading back to the ground floor. Here a fireproof storing-place is being built to contain the films used for transmission.

The Studios

Now we will take the visitor along the corridor back to the tower. First on the right will be the Baird transmitting studio, a large room 67 feet by 29 feet, whose walls have been lined with asbestosite, a sound-deadening substance. Opening out of the studio are an observation-room and two transmission-rooms. Next door is the tele-cinematograph-room, from which films will be transmitted.

Next along the corridor is the control-room for the E.M.I. transmitting studio beyond. In this control-room a balcony has been built where an engineer will sit at the control panel looking through a large glass window in the wall on to the E.M.I. studio. This studio is slightly larger than

the other, being 70 feet by 29 feet. Except for staff cloakrooms situated at the end of the east wing there is nothing else on the first floor.

The Transmitters

The ground floor is taken up with the transmitters. Behind the entrance hall are two rooms containing the switchgear for the power supply. The current will be supplied by the North-Met. from large transformers, which will be erected on the site of the old boiler-house. In case of a breakdown stand-by generators will be installed.

Immediately under the E.M.I. studio on the floor above is the

(Continued on page 142)

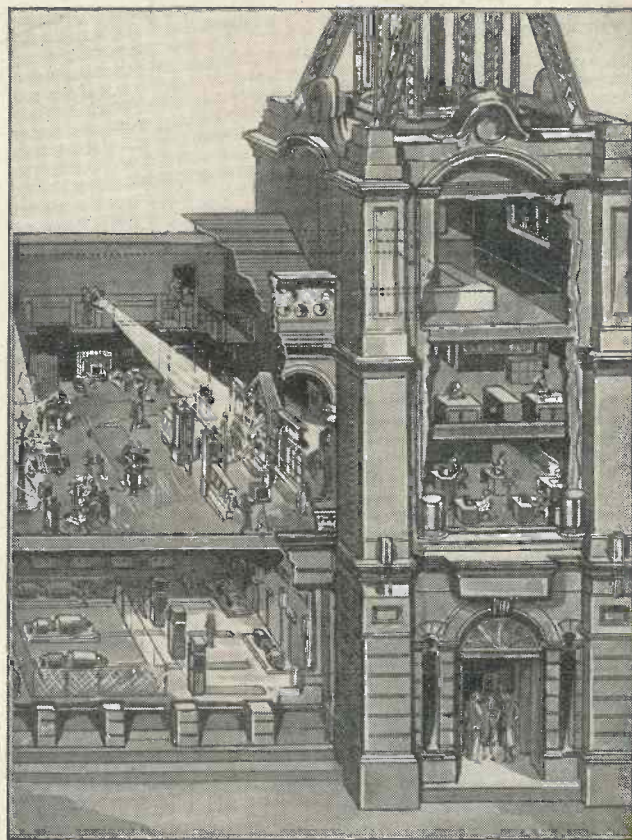

Scannings and Reflections

By THE LOOKER

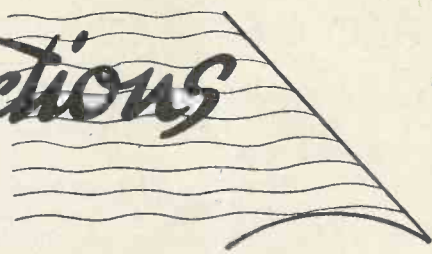

The Versatile Photo-cell

HARDLY a day passes without some new application for the photo-cell being discovered. When a static flash-over takes place from the radiating system of a high-power transmitter there is always the possibility of the current following *via* the ionised path of the spark. At WLW, Cincinatti, it was formerly the practice to detail an operator to watch for such flash-overs, who would then cut off the power. A photo-cell is now employed and when the flash appears at the spark gap the cell is caused to operate a relay which switches off the power and then switches it on again after the discharge has ceased.

Photo-cells are also being employed on the Brooklyn subway trains for the control of the train lighting. When the train enters a tunnel the lights are automatically switched on and they are put out again when the train once more emerges into the daylight.

Baird Television, Ltd.

An order of the High Court of Justice, Chancery Division, dated January 20, 1936, confirming the reduction of the capital of Baird Television, Ltd., from £875,000 to £825,000, was registered by the Registrar of Companies, January 27. A Baird Television issue of 2,100,000 20 per cent. non-cumulative preferred ordinary shares, each of 2s. 6d., has been over-subscribed.

Bush Radio to Market the Televisor.

Whilst "television" is a dictionary word, "Televisor" is the proprietary name of the Baird television receiver. It is now announced that Bush Radio, Ltd., which is linked financially with Baird Television Ltd., has in course of production a range of Televisors and will probably market them soon after the London television programme is inaugurated. Bush Radio agents, to be selected from those on the Bush Radio list,

will distribute the Televisor; these agents are being sent in detachments to the Crystal Palace where they are receiving some training at the hands of the Baird engineers to assist them in selling and servicing the Televisor. Already Televisors produced by Bush Radio are being tested by the Baird people at the Crystal Palace in readiness for the public demand.

Is This Delay?

The Postmaster-General has stated in the House of Commons that it was not yet possible to give an approximate date for the opening of the television broadcasting service, but it was intended that the service should be operated dupring the coming summer. No explanation of the P.M.G.'s statement is available and as it stands it does not mean very much.

English Artists on the Paris Television.

Miss Nona Reed, the daughter of the London comedian, Mr. Herbert Mundin, has given great satisfaction in her singing and dancing numbers at the Paris television station, and we learn that another English dancer, Miss Iris Kirkwhite, of Nottingham, succeeds her.

Televising the Coronation.

Statements in the Press that the Coronation ceremony in Westminster Abbey in May or June of next year will be televised by the B.B.C. are, to say the least, a trifle premature. We are all in great hopes that the ceremony will be televised, but the difficulties in the way, both physical and political, are not to be despised. The lighting inside Westminster Abbey may be altogether too much subdued to allow of the television "eye" giving a reasonable response.

The B.B.C.'s Finance in 1935.

The B.B.C.'s financial report for 1935 shows an increase in the number of licence-holders of 622,540 to a total of 7,403,109. Licences have brought the B.B.C. £327,976 more

than the previous year, the total being £2,038,262. "Other sources"—notably the B.B.C. publications—have produced £85,613 more, the total here being £434,310. Thus, the B.B.C. had a total income of £2,472,572, which is £413,589 more than in 1934. It has spent £195,547 more on programmes, of which amount £40,455 is accounted for by increases in the total of staff salaries, and altogether the sum spent on programmes in 1935, including artists, orchestras, rights and royalties, relay lines, and staff salaries and other expenses, is £1,110,572. Artists, orchestras, rights and royalties alone cost £111,841 more than in 1934, the total being £789,821, which is just over 41 per cent. of the B.B.C.'s net income of £1,918,154 after paying income tax. Salaries chargeable to programmes represent nearly 12 per cent. of the net income, and all other salaries, administration and wages and Governors' fees (£5,207) represents a further 22 per cent. (nearly) of that net income.

Engineering has cost £386,529, which is £51,571 more than 1934, and all other expenditure accounts the sum of £651,310, which is £43,478 more than in 1934. The grand total of expenditure is £2,148,411, a balance of £324,161 being carried forward to 1936. A large sum was expected to be spent on television in 1935, but for various reasons the expenditure has been delayed. While the B.B.C. has made a "profit" on its current account, there is a deficit on the capital account of £677,030. Capital expenditure is very heavy and further necessary capital schemes will involve high expenditure for some time to come. The B.B.C. in 1935 provided 68,795 hours and 38 minutes of transmission time.

The First Co-axial Cable.

Outside Broadcasting House a few days ago I saw a large drum containing a co-axial cable. It did not excite any interest in the ordinary passer-by although a few people, probably the more technically minded,

MORE SCANNINGS

stopped to examine it. This cable, as a matter of fact, will be the first of its kind to be laid in this country and it is the commencement of a line from Broadcasting House to the Alexandra Palace. The Post Office is responsible for it and it is being laid at the request of the B.B.C. to connect Broadcasting House with the Palace. This, it will be noted, is the result of a recent decision and is described as being for experimental purposes, presumably so that certain items at Broadcasting House can be relayed for re-transmission on the ultra-short waves from the Palace.

Television in the Provinces.

Speaking of co-axial cables it has generally been assumed that as the Post Office have in hand a project for laying a cable of this type to Birmingham this will be the first provincial centre for television. This, however, is perhaps a hasty conclusion which, when all things are taken into account, is probably incorrect. To be of use, a regular television service would have to be inaugurated in Birmingham and this would entail the use of the cable for several hours a day as a regular thing. On the face of it it does not seem likely that the Post Office would go to the huge expense of laying this cable and then relinquish its use for very considerable periods. Then, again, I am by no means certain that a cable of this length will answer the purpose of television, though obviously this installation will provide a basis of experiment.

Unofficially it has been stated that there will be no television in the provinces until twelve months' experience has been obtained with the London transmitter. It can be assumed that by that time very many more developments will have taken place and possibly new systems tested out. I think it is more likely, therefore, that when it is decided to extend activities the opportunity will be taken to try out any new systems that seem worth while.

A Mystery Transmission.

Very frequently of late what appears to be a thirty-line transmission has been heard on round about 41 metres, but nobody seems to know from where it emanates. It is quite a good signal and is usually on be-

tween nine and ten in the evening; it may be some amateur experimenting with television, but somehow I don't think so. Perhaps some reader can provide some information regarding these transmissions.

Implosion.

There is a good deal of speculation in technical circles regarding the possible danger of the cathode-ray tube collapsing. I have had personal experience of three tubes that "burst" and though no damage resulted to anybody the occurrences were rather alarming. Of course, a tube "bursts" inwardly, or implodes, but this fact does not lessen the potential danger for the particles by no means come to rest at the centre of the tube, and for all practical purposes the occurrence may be looked upon as an explosion. In one instance referred to the tube went off before it had even been unpacked; it was in fact merely standing in its carton undisturbed. There was no apparent cause for the second one bursting either and in this case broken pieces of glass marked the wall. The third was the result of careless handling.

When one considers the enormous pressures that are on these tubes it is surprising they stand up as they do. Their strength lies in their shape, and it is easily conceivable that any defect in this respect will tend to weaken the tube. So far as I am aware no precautions have as yet been taken in receivers to prevent the possibility of accidents and it would appear to be desirable to place a glass covering over the end of the tube as a precaution against flying glass.

On this score the indirect method of viewing as employed by the Baird Co. appears to offer certain advantages, for the actual tube is well outside visual range, and although an implosion might be alarming it is improbable that any damage would be done to anyone viewing the picture.

Mechanical Systems.

I am frequently asked how the mechanical systems are progressing under the somewhat severe demands of 240 lines. I can only say that sponsors of the various systems are quite optimistic regarding future results and, although they have been set a difficult problem, their faith has

not wavered. Like many others, they are naturally experiencing some difficulty owing to no transmissions being available. Modulation, I am told, presents no difficulties at the high frequencies involved, but judging from casual remarks synchronism is likely to be the principal difficulty though to what extent it is difficult to say until the B.B.C. start transmitting. There is no doubt but that mechanical systems offer many advantages if they can be made practicable for the new standard and it is significant that some of the concerns which are developing cathode-ray television have not lost all their interest in mechanical systems.

Mains Supply for Unwired Homes.

The Birmingham Corporation Electricity Supply Department is to be congratulated for its offer to supply current for wireless purposes to premises that are not wired for electric light. There are still a very large number of houses that are not wired, and residents of these will no doubt be glad to take advantage of the offer. Under this scheme when the connection between the main and the house does not exceed sixty feet a fee of only ten shillings is charged and current is supplied at power rate subject to a minimum payment of five shillings a quarter. Many people will be glad to have the advantage of mains supply, but may not be prepared to go to the cost of wiring the house. It is a scheme that other electricity undertakings might follow with advantage.

Field Strengths of the B.B.C. Short-wave Transmitter.

For the past few weeks 7-metre transmissions have been put out from the roof of Broadcasting House and a van has been touring the country north of London plotting the field strengths in different areas. The results and purpose of these experiments are for the present hush-hush, but obviously they are in order to obtain data for the coming television transmissions. Of course, sound only has been transmitted, and for this either the National or Regional programme has been taken. By the kind co-operation of several friends in different parts I have been able to form some idea of the results, which vary from about 7 microvolts

to 2 millivolts. No precise measurements have been possible, but it is clear from the reports that I have received that reception is decidedly patchy and that it varies very considerably within quite small distances.

Screening effects have been very noticeable and this seems to imply that in the majority of cases the television aerial will have to be erected as high as possible and clear of surrounding buildings if the best results are to be obtained. The aerial will, in fact, form quite an important feature of the installation. There should, however, be little difficulty regarding aerial height for the actual aerial will be of only quite small proportions. I remember that the Baird Company, for their demonstrations during the early part of last year, merely used a light bamboo rod about twelve feet long to which a couple of lengths of wire were attached. This was placed on the roof of their premises in Victoria Street, but later it was brought into the same room that the receiver was in and no appreciable difference was observed in the received picture.

30-line Transmissions from Holland

Readers who are in possession of thirty-line receivers will be interested to learn that transmissions which cor-

respond to the old B.B.C. transmissions are now being put out from Holland and have been well received in this country. The picture ratio is 7×3 and $12\frac{1}{2}$ per second, in fact they are the same in all respects as those to which we are accustomed, including vertical scanning. The wavelength is approximately 80 metres. The one snag is that the broadcasts are between 6.10 and 8.10 on Sunday mornings so they necessitate early rising. So far as I have been able to ascertain these broadcasts are likely to be continued for some considerable time, so it will be worth while digging out that old 30-line receiver.

W2XEM

Many readers have been sending me reports on the reception of W2XEM using a wavelength of 9.966 metres, 30.1 megacycles. B.R.S. 1784 has sent me some details of this station for the benefit of readers in doubt as to what they actually have been receiving.

"The Transmission and Reception of Micro Waves" by C. G. Lemon.

The above preliminary article published in the February issue of TELEVISION was, we regret, inadvertently published without the permission of the author and of the Radio Society of Great Britain.

W2XEM, QRA Newark, New Jersey, is used for calling police cars, although it is only intended to have a nominal range, it is heard in Europe up to R9. The transmitter, built by Western Electric, has an input of 500 watts and is capable of being modulated up to 100 per cent.

The line-up consists of two units. The first a 50-watt modulated amplifier feeding a 500-watt class-B amplifier. The frequency is maintained to within 25 cycles by using a conventional temperature controlled crystal. The third harmonic of the crystal is selected to give the transmitting frequency.

Messages are despatched from Police Headquarters, about half a mile from the transmitter, which is housed on the 34th floor of Newark's tallest building.

The aerial is a half-wave vertical with feeders 200 ft. long. Reports are appreciated from British listeners and should be addressed to W2XEM the Director of Public Safety, City Hall, Newark, New Jersey.

Silent Periods

Dr. J. H. Dellings, Chief of the Radio Section of the American National Bureau of Standards, has just made an interesting discovery. He finds that a peculiar silent period occurs every 54 days. During that period all short-wave stations are wiped out on the illuminated side of the globe. The dark side of the globe is not affected. So far no theory as to the cause has been put forward.

Progress at the Alexandra Palace

(Continued from page 139).

E.M.I. transmitter-room, where massive concrete beds provide foundations for the power plant. One side of the room will be taken up by the controls which will be placed on a raised wooden floor, with the cables in ducts beneath. Beyond is the Baird transmitter-room, laid out on similar lines.

Cinema Projectors

Also opening off the corridor, which in this case will contain the power cables and has been made fireproof, is a fireproof projection-room where two cinema projectors will be installed. Next to this is a tiny cinema, where films that are to be televised will be inspected.

Further down the corridor is the kitchen—the old Palace kitchen, which has been completely converted.

A large portion of it will be turned into a cafeteria for the staff and artists. The Palace Trustees-room has been converted into another staff-room.

Beyond the Baird transmitter-room is the carpenter's workshop, where all the scenery to be used in the two studios will be manufactured. Beneath the workshop, in the only part of the large basement to be used, will be the boiler-room, for the whole of the B.B.C.'s portion of the building will be heated by hot-water radiators.

No Theatre

Air-conditioning is not being employed, but fans are being installed.

More than ninety men have been employed on the work. The engineers found the task of reconstructing the interior of the Palace more difficult than was expected, but the work is practically up to the date scheduled.

Some Television Terms

Photon

A unit denoting the illumination of the retina of the eye with a pupil aperture of one square millimetre by an object having an intensity of one candle per square metre.

Lumen

A unit representing a quantity of light: 4 π lumens, spherically distributed, are emitted by a point source of one candle-power.

Phase Distortion

The effect produced by certain frequencies which go to make up the picture travelling at a different speed to others, with the result that they are out of place and produce distortion in the picture.

FOR THE BEGINNER

HOW THE CATHODE-RAY
MAKES THE PICTURE

THE diagram shown here is a continuation of the series which we showed last month and illustrates the way in which the picture is formed on the fluorescent screen.

The electron stream is produced by the potentials applied to the electrodes of the tube from the H.T. unit marked. The transformer and valve produce 3,000 volts, which is smoothed by the condensers and applied to the tube anodes.

The "grid" G of the tube has a negative potential applied to it from the bias resistance shown, but the lead to the grid is taken to the output terminals of the receiver.

The action of the grid is similar to that of the grid of a valve—when a signal is applied the anode current (in this case the beam current) increases

and decreases, giving light and dark patches on the fluorescent screen.

In the diagram a signal received from the aerial is applied to the bias potentiometer and has momentarily increased the grid bias, shutting off the beam and causing a blank to appear in the electron stream as it is swept to and fro across the screen. The fluorescence has disappeared from that part of the screen, leaving a dark patch.

We see that there are four components for the production of the picture: (1) The supply unit for the tube; (2) the vertical scanning circuit; (3) the horizontal scanning circuit; (4) the television receiver. In practice (2) and (3) are combined in one unit and fed from the A.C. mains together with the supply unit.

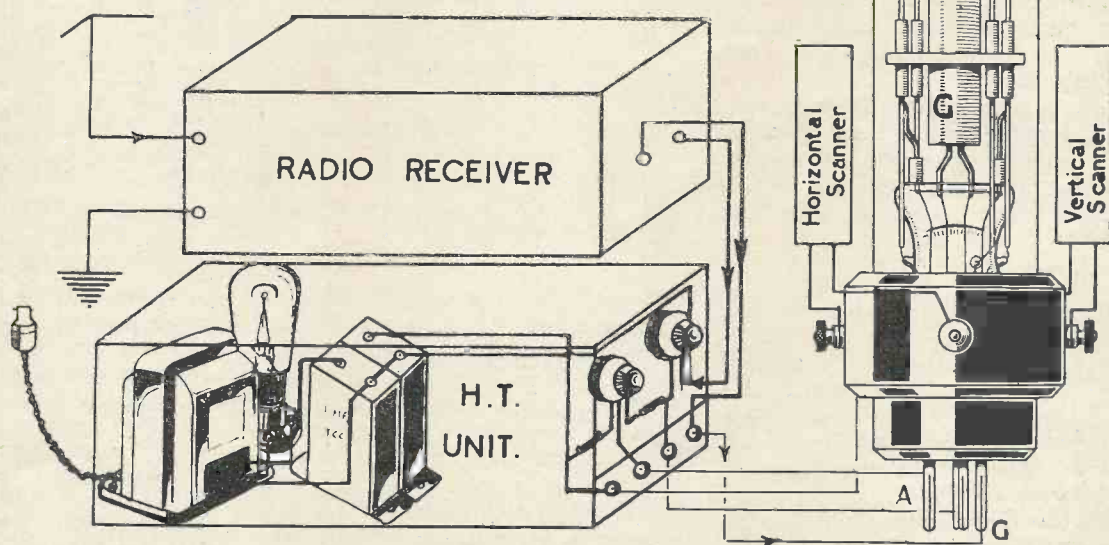
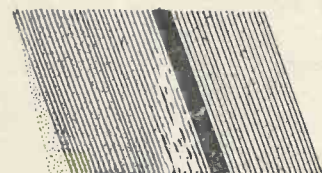

THE EDISWAN CATHODE-RAY TUBE FOR TELEVISION

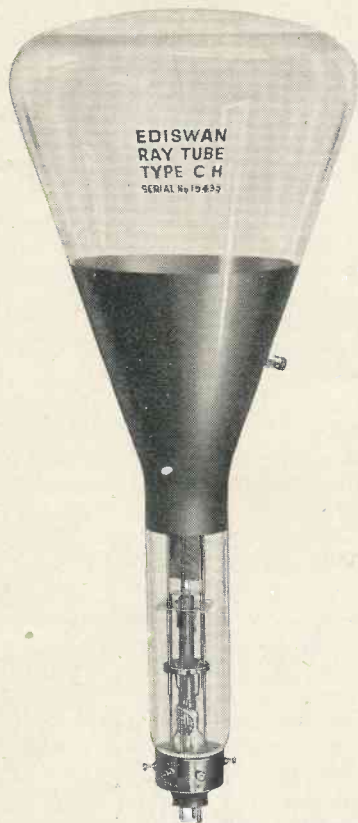

The Ediswan Type CH cathode-ray tube with a 25-centimetre screen for television.

THE Edison Swan Electric Co., Ltd., have recently developed a cathode-ray tube of the high-vacuum type specially designed for television. This is the type CH and the material with which the screen is coated yields a high luminosity white fluorescence which makes possible the production of pictures of a very pleasing black and white. Special attention in the design has been paid to the focusing properties of the beam and the modulation characteristics with particular reference to picture reproduction.

As will be seen from the specification below the screen has a diameter of 25 centimetres and the tube length is 60 centimetres.

Cathode heater voltage (approx.) 2.0
Cathode heater current (amp. approx.) 1.3

1st anode potential (approx.) 1,200
2nd anode potential 3,500

Negative grid potential (approx.) 100/200

Sensitivity in mm./volt (where $\frac{750}{V}$)

V is final anode voltage
Tube length (cms.) 60
Screen diameter (cms.) 25
Indirectly-heated cathode.

A photograph of the CH tube appears on this page and it will be seen that the construction follows gener-

ally accepted practice, the electrode assembly being mounted on a glass pinch with rigid support for the grid, anodes and deflector plates. The anode lead is shielded by a glass tube in order to avoid possibility of leakage at high voltages. The electrode structure is connected to the pins of a standard 4-pin base above which is an ebonite ring provided with four terminals for making connection to the deflector plates. It is probable, however, that a form of multi-contact base will eventually be fitted.

Full modulation can be obtained with this tube with from 10 to 20 volts on the shield and good results will be obtained if the signal is loud headphone strength. If desired, the beam can be deflected magnetically, coils being attached to the outside of the tube parallel to the deflector plates. The coils must be as nearly

deflection obtained is within the effective diameter of the screen. The amplitude of the potential supplied to the deflector plates can be adjusted by the usual methods of potentiometer or transformer, care being taken that the circuit under observation is not appreciably modified by their insertion. The beam is easily influenced by external magnetic fields. It is advisable, therefore, to surround the tube with a magnetic shield, which should be earthed. Steel shields specially designed for the purpose can be supplied. Also the tube should be placed as far as possible from local sources of interference, such as generators or electro-magnets. Should the deflection of the beam not be symmetrical with reference to the screen after these precautions have been taken, it can be deflected by (1) a permanent magnet placed in the rear

The circuit of the exciter unit.

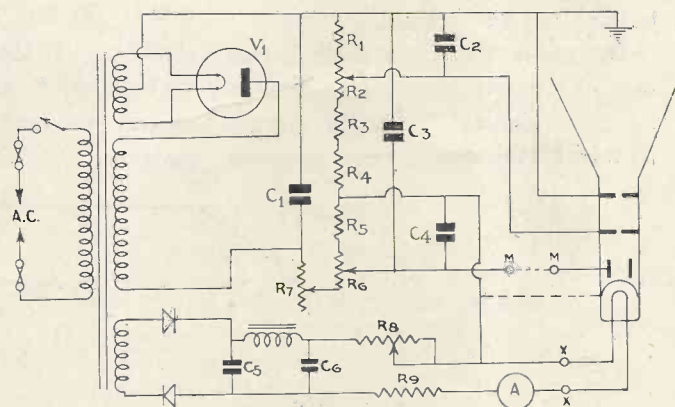

as possible identical, and should have a diameter approximately equal to the distance between them.

A suitable exciter circuit is shown by the diagram and the following notes are the maker's general operating instructions: When only one pair of plates is in use, the other pair should be short-circuited and earthed in order to prevent charges accumulating on them. A preliminary test should be made to ensure that the

of the shield; (2) by means of a small biasing battery connected in series with one deflector plate, or (3) a battery-operated coil attached to the side of the tube. The spot should not be allowed to remain stationary on the screen for any appreciable time or the screen will be damaged.

The price of the CH tube is £12, and the makers are The Edison Swan Electric Co., Ltd., 155 Charing Cross Road, London, W.C.2.

MECHANICAL FILM TRANSMISSION

A DISCUSSION OF ITS POSSIBILITIES WITH WELL-KNOWN SYSTEMS

By L. M. Myers.

This is the first article of a short series dealing with high-definition mechanical-optical film transmitters. The article below deals with the simple apertured disc transmitter and in the later articles other well-known mechanical systems will be considered and their efficiencies discussed.

NOW that it might appear that the death knell of mechanical-optical television systems is being sounded in every country adopting the more recent methods of electron-optical scanning, it may be well to pay tribute to the only present-day use to which the former systems can be applied with fair results. Even so, we must give some attention to the limitations which beset mechanical-optical systems having regard to efficiency for increasing definition.

We shall consider first the simple aperture disc, which has, perhaps, played the most important part of all in the early and later development of mechanical-optical systems for the transmitter and for the receiver.

It was first stated by Möller in "Fernsehen," for January, 1932, p. 36 (just over four years ago) that the efficiency of a mechanical-optical scanning system increased as the square of the speed factor for the aperture and lens-disc arrangement, and as the fourth power of this factor for the mirror-drum arrangement. By speed factor is meant the number of revolutions of the scanning system per one complete picture. In the early days, when the aperture disc received a spirally disposed system of apertures, the speed factor could not enter into consideration, because the spiral completed the one frame scan. The case is different for the film transmitter, owing to the fact that the film can be run continuously through the gate and the apertures in the scanning disc can be equidistant from the centre. Thus for a 240-line scan, the disc should bear 60 apertures at a speed of 6,000 r.p.m. The picture-frequency in this country is 25 per second, this corresponding to a disc speed of 1,500 r.p.m., if there is to be one complete revolution per picture. In the case considered, therefore, the speed factor will be 4.

By the efficiency of the scanning system is generally understood the amount of light flux in lumens reaching the photo-cell. We shall take first the case of the aperture disc scanning the continuously moving film.

Let B be the brightness of the light source in candles/cm².

n be the number of lines in the scan.

K be the picture ratio; i.e., $K = \text{Length}/\text{Width}$, the length being in the direction of scan.

N be the number of picture elements. $N = Kn^2$.

D be the effective diameter of the scanning disc. This will be the actual diameter of the apertures.

a^* be the area of the disc aperture.

a be that area of the light source corresponding to the disc aperture (see Fig. 1).

d be the diameter of condenser.

r be aperture ratio of condenser.

l be the distance between objective and light source.

l' be the distance between objective and disc.

In order to effect the necessary scan the light source is first imaged on the line joining successive apertures of the disc. This light, after being scanned by the film, then passes to a second image in the plane of the film and thereafter finally reaches the photo-cell. This is the simplest and, incidentally, the best of all the

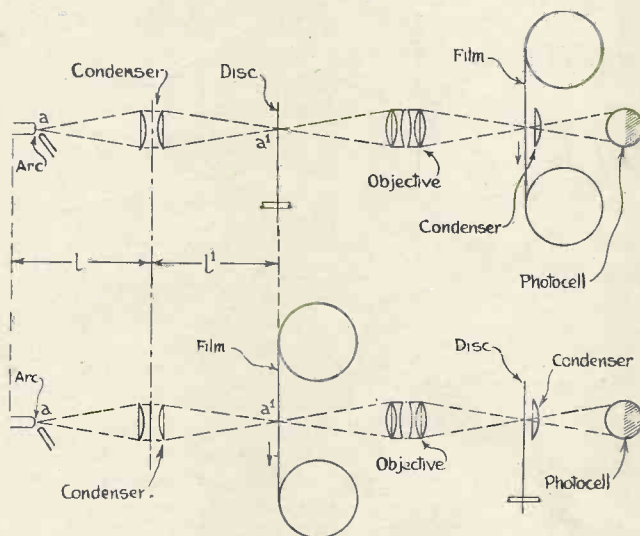

Fig. 1.—Simple optical layout of disc film transmitter.

optical layouts for the disc film transmitter. The imaging of the light source first on the film itself and then on the disc is found to possess certain inherent advantages and it appears to be the commoner practice. In both cases the efficiency expressions are identical.

The amount of light eventually reaching the photo-cell is equal to that passing into the first objective coming from that area in the light source corresponding to the aperture in the disc, after taking into account the losses encountered in its progress through the optical system.

The original amount of light is given by the well-known expression

$$F = B a \omega$$

where ω is the solid angle subtended by the condenser at the area of the light source. In order to obtain the efficiency expression of almost any mechanical optical television system, the values a and ω have to be given

Dr. ZWORYKIN on THE ELECTRON MULTIPLIER

"Television and Short-wave World's" Exclusive Report of the Lecture given by Dr. Zworykin at the Institution of Electrical Engineers on February 5th.

DR. VLADIMIR ZWORYKIN, the inventor of the Iconoscope, was invited to lecture at the meeting of the Wireless Section of the Institution of Electrical Engineers on Wednesday, February 5. To a crowded audience he described his new invention in electron multipliers and electron lenses, and the following is a condensed account of his paper:

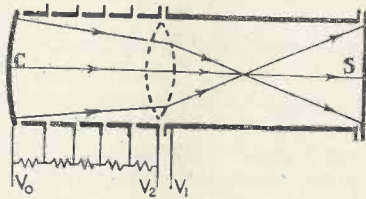

Fig. 1.—A simple electron lens system. Electrons from the cathode C are focused by the potentials applied to the cylinders and form an image on the screen S.

The beginning of electron optics can be said to be older than the discovery of the electron itself. It was known that a cathode-ray beam would cast a sharp shadow on a fluorescent screen from an object placed in its path, and in respect of this

it was known that the cathode-rays resembled light rays.

It was not long after the discovery of the electron itself that work on the calculation of electron paths formed the groundwork of the science of electron optics. Since that time these particular theories have been studied in increasing detail as the importance of electron optics has become more and more recognised. Of particular interest is the calculation of the paths of electrons in a symmetrical field. These types of field—electrostatic and magnetic—both tend to cause the electron path to bend in a manner similar to that in which light is bent.

Two of the most important applications of electron optics, and ones that have been most fully exploited, are the electron gun and the electron microscope. The first is characterised by the fact that a very small electron source has to be forced into a very small image or spot. In the electron gun, both the spot and source producing it are close to the axis of symmetry of the lens, and relative distortion between the spot and source is not of great importance. (As an example of the fineness of spot

obtainable, a 340-line television picture was shown.) The theory of this brand of electron optics is fully dealt with by Bruche and Scherzer in a monograph.

The Electron Microscope

A newer application is in the development of the electron microscope and electron telescope. In these in-

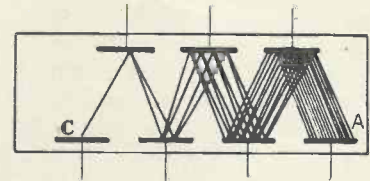

Fig. 2.—Showing the principle of the electron multiplier. The cathode C is the primary source of electrons, which are reflected to the anode A.

struments the image is focused on a semi-transparent photo-electric cathode, the electrons from which are focused by means of electrostatic lenses on to a screen placed at the opposite end of a tube (Fig. 1).

The requirements of such a microscope are that the image be free from distortion, the circle of confusion must be small, and as large an area as possible of object and image must be available. The degree of magnification of such systems varies between one-half to three times.

In order that the electron lens system of Fig. 1 should operate successfully the image must be able to be focused by changing the relative position of the lenses in the system.

Changing the position of the cylinders which form the lens system is very difficult though not impossible when the tube has once been evacuated and sealed off. To build a "fixed-focus" tube, giving perfect focus over the whole screen is practically impossible. The solution to the difficulty lay in devising a means of changing the focus electrically, by changing the potential applied to the electrodes. In changing the curvature of the equi-potential surfaces it

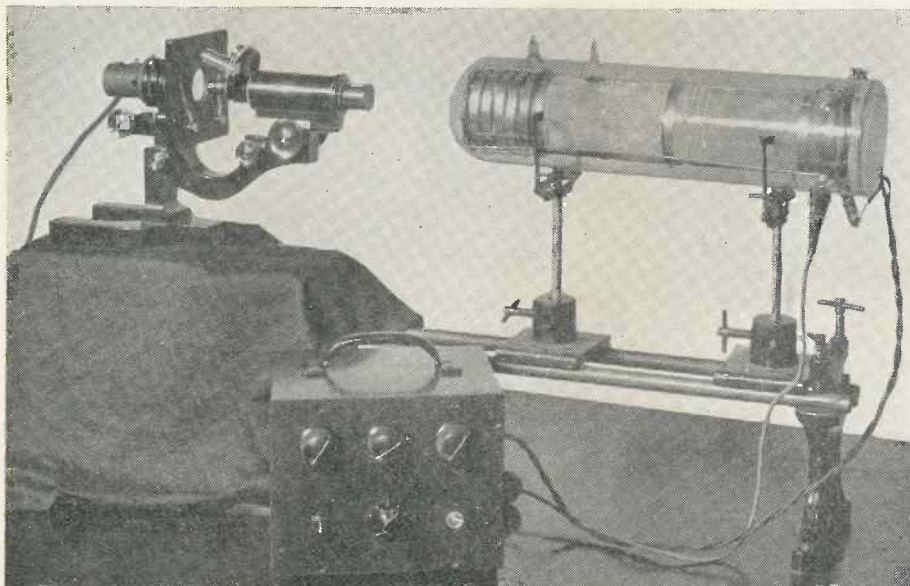

The image tube (right) is used with an infra-red microscope. By means of this device, sensitive to the infra-red rays, it is foreseen that the development of hitherto baffling minute organisms may be brought within the range of human vision. Such cells, in the past, have been studied by means of intense light or stains that often kill them.

ADVANTAGES OF THE ELECTRON MULTIPLIER

is important that the field next to the cathode is not changed at the same time. This is avoided by providing a number of separate cylinders (up to six) for the first part of the lens, as shown in Fig. 1, and applying a graded difference of potential to each cylinder. This potential gradient is obtained from a series of resistances shown, some of which can be conveniently incorporated in the tube.

(The lecturer showed slides of the pictures obtained by focusing the cathode on external scenes.)

An important property of the electron telescope is that the object can be illuminated by infra-red rays and still be made to yield a visible image on the screen. This property is of great importance in the application of the telescope to fog signalling devices, etc.

If the tube is mounted as a camera in front of a microscope, the slide can be illuminated by infra-red light, and by this means it is possible to examine live and moving specimens,

The cathode used in the tube is a semi-transparent layer of caesium-oxide-silver, and the process of depositing this film is very similar to

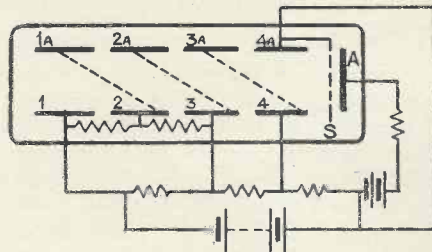

Fig. 3.—The circuit used for supplying potential to the electron multiplier. The initial stage resistances can be inserted in the bulb.

that used in making caesium photo-cells.

There is another field in which the application of electron optics is extremely important, and that is in the design of secondary emission multipliers. It has been known for many years that secondary electrons

ing a small electron current by means of the secondary electrons produced has been investigated by various workers, including Farnsworth.

The problem of making a suitable electron multiplier to give a high gain is not so simple as may seem at first glance. The principle is shown in Fig. 2, in which a photoelectric cathode, C, can be illuminated by an external source, and the electrons produced are guided to a plate on the opposite side of the tube, where they give rise to an increased number of secondary electrons. These electrons are then attracted to a second plate diagonally opposite the first, and so on, until by successive reflection arrive at the collecting electrode A.

Such a multiplier in the form shown in the figure would be almost completely inoperative, for the reason that practically all the electrons in the track would not go to the first collecting electrode, but would traverse the length of the tube, owing to



A scene projected in infra-red or "black light" on the fluorescent screen of the image tube.

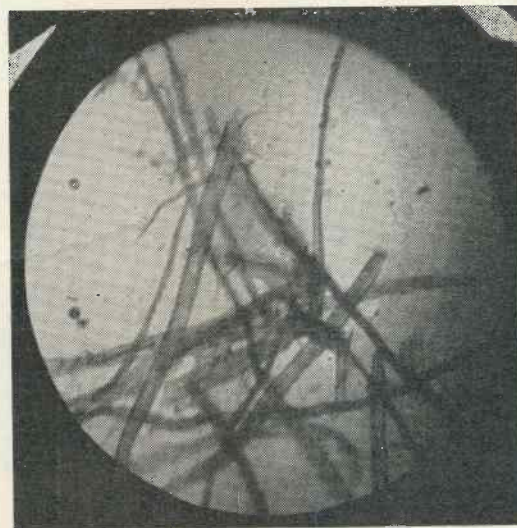

A visible image of a micro specimen on the screen of a tube.

bacteria, etc., which would normally be killed by ordinary light, or by the various staining processes usually adopted.

If the lens is used in conjunction with an aperture inserted in the tube, the magnification depends on the position of the aperture with respect to the two sides of the lens system, and a wide alteration of magnification is possible by altering the effective position of the aperture.

are emitted from a sensitised surface when primary electrons of sufficient velocity are allowed to strike it. In the ordinary thermionic valve this secondary emission is usually a handicap, as it increases the space charge and decreases the control of the grid.

The first practical use to which secondary emission was put was by Dr. Hull in the "dynatron," and since that time the idea of amplify-

the potential applied to the collector.

In order to construct a satisfactory multiplier it is not only necessary to have a high ratio of secondary to primary emission, but a lens system must be provided to focus the electrons on each succeeding target.

To obtain a good emissive surface, i.e., one having a high ratio secondary to primary electrons, experiments were made on a large number of sub-

(Continued on page 191)

A NEW METHOD OF INTERLACED SCANNING

By L. S. Kaysie

Details of a new method of interlacing which dispenses with the odd half-line.

THE use of interlaced scanning is justified on the ground that it gets rid of the "flicker" effect which occurs in ordinary "straight"

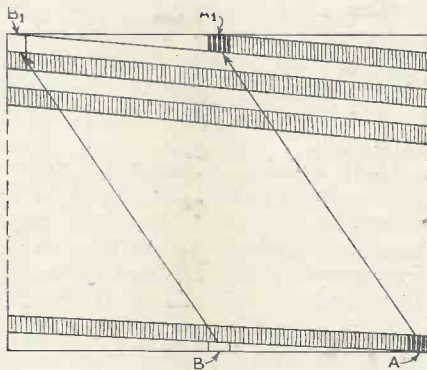

Fig. 1.—Illustrating method of interlacing.

scanning, even when the picture repetition rate is as high as 25 a second. This may, perhaps, be described as an attempt to "paint the lily"; but on the other hand, high-definition television is setting a standard of its own in these matters, and if 25 frames a second still leaves evidence of flicker then the imperfection must be removed by hook or by crook.

In the kinema theatre, where the normal film-repetition rate is 24 a second, the modern practice is to eliminate flicker by throwing each of the 24 frames twice on to the screen, instead of once, so that the eye actually receives 48 separate impressions per second.

Of course, in theory, it would be possible to retain the "straight" system of scanning in television, and to get rid of flicker by doubling the rate of picture repetition, but this solution is not satisfactory in cold practice. For one thing it involves doubling the frequencies required for transmission, which, in turn, means doubling the side-band width occupied in the ether. Moreover any addition to the frequency-range adds considerably to the difficulty of handling and amplifying the signals, both at the transmitting and receiving ends.

Interlaced scanning offers a reasonable compromise which, particularly

in high-definition work, gets rid of flicker with the minimum of inconvenience. It amounts to this: instead of keeping the same line frequency and doubling the number of pictures transmitted per second, the line frequency is halved and the picture frequency is doubled. That is to say the number of pictures transmitted per second becomes, say, 50 instead of 25, whilst the number of scanning lines contained in each picture is reduced from, say, 405 to 202½. The odd "half-line" is significant and will be referred to again.

The Odd Half-line

Each individual picture, taken by itself, is complete, but naturally less perfect in definition than if it had been scanned by the whole 405 lines. But when projected in pairs, and properly interlaced on the screen, the resulting combination gives a complete and perfect representation. Naturally the two pictures which go to form the perfect pair must be thrown on to the screen in slightly staggered or "de-phased" relation, so that they fit between or "interleave" with each other, instead of occupying exactly the same position.

This is where the odd "half-line" comes in. Incidentally it involves a slight modification of the ordinary time-base circuit used for "straight" scanning because the line frequency is no longer a "whole-number" multiple of the picture frequency.

In Fig. 1, the manner of interlacing is illustrated by the alternate clear and shaded lines, which are, of course, shown greatly enlarged. It will be seen that the shaded spot A at the end of one picture must be returned to the centre point A1 of the first line of the next "repeat." It cannot start nearer the left-hand end of that line, because there is no room for it without overlapping and so "blurring" the corresponding line of its companion picture. For the same reason the last "stroke" of the unshaded line finishes at B, half-way along the bottom traverse, the fly-back movement taking it back to the point B1, ready to begin the next "repeat."

The presence of the odd half-line in each frame prevents the use of a single frequency-doubler, to link the "line" and "frame" saw-toothed oscillators in the time-base circuit, unless at the same time one uses some de-phasing adjustment, to pre-

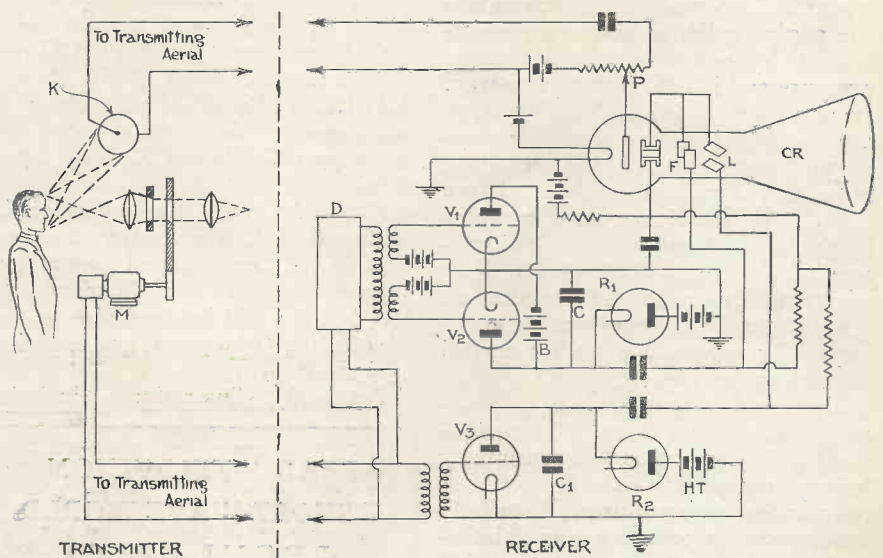

Fig. 2.—Time-base circuit for new method of interlaced scanning.

vent overlap. A further complication arises from the fact that the new high-definition television programmes are going to be shared equally between the Baird Company, which uses "straight" scanning, and the Marconi-E.M.I. Company which prefers the interlaced system. It is, therefore, necessary to find a receiver which can readily be adapted to handle both types of transmission with equal facility.

Fig. 2 shows a time-base circuit recently developed by the Electrical Research Products Inc. of America for "interleaving" in a new way.

In the first place, the odd half-line disappears, both frames being scanned by exactly the same number of complete lines. In the second place, the necessary "shift" or displacement of one frame relative to its "opposite number" is secured by applying a slight but definite biasing-voltage to the deflecting-electrodes of the cathode-ray tube during the scanning of one frame. During the scanning of the next frame, this biasing voltage is removed.

The resulting "shift" in the position of one set of lines due to the presence of the biasing voltage is

sufficient to interlace them accurately with the succeeding set of lines on the fluorescent viewing-screen.

Starting at the transmitting end, the object is scanned in the ordinary way and picture-signals are derived from the photo-electric cell K. Simultaneously line-scanning impulses are produced by the motor M, and the two sets of signals are then combined for transmission.

At the receiving end, the picture signals are fed at P directly to the control electrode of the cathode-ray tube CR. Simultaneously the synchronising impulses are applied to trigger a gas-filled valve V₃, and so discharge a condenser C₁ which applies saw-toothed oscillations to the line-deflecting electrodes L of the cathode-ray tube. The condenser C₁ is charged from the H.T. source through a constant-current valve R₂.

The framing-control for the interleaved pictures is shown in the centre of the diagram. The condenser C, which frames both pairs of interleaved pictures, is charged up through a constant-current valve R₁ from a source of high-tension. It is discharged by two separate valves V₁, V₂ acting in push-pull. The

gas-filled valve V₁ first applies one set of framing oscillations to the electrodes F of the cathode-ray tube, and the gas-filled valve V₂ then supplies a second set, which must interleave with the first.

The gas-filled valve V₂ completely discharges the condenser C₂, though when the valve V₁ is in action the discharge is not complete. The reason is that the battery B, which is in the plate circuit of V₁, makes its presence felt across the condenser C during the second discharge. This applies a biasing voltage across the deflecting electrodes F sufficient to shift the lines of the second picture by the amount required to interlace them with the lines of the first picture.

One definite advantage of the arrangement is that the impulses required to control the framing operations are derived, through a single frequency-divider D, from the same synchronising signals that control the line-scanning condenser C₁. At the same time if the biasing battery B is switched out of action, the time-base circuit can be used to receive pictures sent by ordinary "straight" scanning.

"The Uses of the Cathode-ray Tube"

(Continued from page 160)

duration, and several cardiac cycles therefore remain visible simultaneously on the screen.

Compression and fuel detonation characteristics of internal combustion engines are obtained either by the use of a piezo-electric crystal mounted in a special holder which is screwed into the engine cylinder head or a resistance which responds to variations of pressure and is used in the same way. In the case of the crystal, voltages are developed according to the pressure of the gas and the resulting potential is applied to the cathode-ray tube. The resistance type operates by the application of an external voltage in a local circuit and the voltage varies according to the pressure on the resistance. The circuit arrangements for use with a quartz crystal are shown by Fig. 1.

New applications of the cathode-ray tube in the spheres of measurement and observation are continually being made and it is clear that its possibilities have not as yet been fully developed. It provides a most interesting instrument for further fields of research.

A Plymouth Lecture

THE usefulness of the cathode-ray tube projector was explained by Mr. G. Parr, of the Edison Swan Electric Company, in a lecture on new principles of television, given at the Plymouth Athenaeum on Tuesday, February 11, in conjunction with the west country district of the National Society of Radio Engineers and the Plymouth and Devonport Technical College. Mr. S. Gordon Monk, M.Sc., B.Sc., A.M.I.E.E., head of the electrical engineering department of the Devonport Technical College, presided.

Not only could the projector be employed for the testing and recording of speech and radio frequency currents, Mr. Parr pointed out, but it could be used also to test the efficiency of wireless and electrical equipment.

Practical illustrations included

**READ TELEVISION
& SHORT-WAVE WORLD
REGULARLY**

traffic vibrations from the street outside represented on the screen of the cathode-ray tube, and by similar means impressions of variations in the sound of a human voice were also shown.

A vote of thanks was accorded to Mr. Parr on the proposition of Mr. A. S. Barnes, engineer in charge of the Plymouth B.B.C. Station, seconded by Mr. W. L. Cornish.

Blackpool and Fylde Short-Wave Radio Society

Readers in Blackpool should remember that the new Blackpool and Fylde Short-wave Radio Society is now busy arranging future programmes and field days. All the information required can be obtained from the Hon. Secretary, BRS 2078, H. Fenton, 25 Abbey Road, Blackpool, S.S.

Tunbridge Wells and District A.T.S.

This Society is particularly active arranging future programmes and short-wave enthusiasts should get in touch with the Secretary, W. H. Allen, G2UJ, 32 Earls Road, Tunbridge Wells. Numerous transmitting amateurs are numbered amongst its members, while BRS and A.A. amateurs will be assured of a welcome.

Receiver
Data

Our Readers' Views

Eiffel Tower
Transmissions

U.S.A.
Developments

Correspondence is invited. The Editor does not necessarily agree with views expressed by readers which are published on this page.

5-metre
Transmission

Television Receiver Data.

SIR,

The recently published specifications of the Marconi-E.M.I. and Baird television systems shortly to be broadcast from the Alexandra Palace station did not include sufficient information for the designers of receivers and amplifiers to work on. For example, although it is stated that for optimum definition the low-frequency response should be level to 2 megacycles there is no mention of any permissible tolerances in respect of either amplitude or phase conditions at that frequency. Likewise at lower frequencies (it is stated that 2 megacycles is not essential) one needs similar details.

I am sure many struggling designers would welcome official information of this kind.

J. BEARDSALL (London, N.).

Developments in U.S.A.

SIR,

What interests me is the fact that the by-products of television, as it were, are appearing in America before electronic television itself.

The Farnsworth Multipactor tube was a by-product of television research, and now the R.C.A. image tube comes forward, which is also a by-product of television research.

The R.C.A. image tube is, in short, an electronic pick-up, and receiver, all in one tube. The electron beams are ingeniously focused, or "magnified," electrostatically.

I may mention that electronic television will be out in this country within a few months. This city is fortunate, since all of the worthwhile research centres here, Farnsworth is on the outskirts of the city, and R.C.A., of course, is in Camden, which is just across a river.

Recently, in the Farnsworth laboratories, I saw the preliminaries of the small projection tube for electronic television. This will, I feel, be sensational.

The Federal Communications Commission has, it seems, asked Farnsworth and R.C.A. to settle between themselves the "lines and frames." It seems that it will be 343 lines at 60 pictures per second, interlaced.

American power lines work on 60 cycles, and thus, 60 cycles for vertical scanning will eliminate much interference.

From my own observations I think Farnsworth's Philadelphia station will be transmitting before the R.C.A. station from the Empire State Building, in New York City.

Farnsworth is about to lay some ten miles of special co-axial cable, made to his specifications by the General Cable Co., from his laboratory on the outskirts of the city, to the Franklin Institute, in the heart of the city. This will be the first co-axial cable ever laid in America for exclusive use in television experiments.

GEORGE H. ECKHARDT
(Philadelphia, Pa., U.S.A.).

The Eiffel Tower Transmission

SIR,

A few days ago, listening to some people highly placed in French television, I heard that the new transmitter of 10 kilowatts was not to be erected in the Eiffel Tower, as is supposed, but at Yssy des Moulinaux at the Porte de Versailles Paris, south-west.

Transmissions are to be tried at 25 or 24 pictures per second, twice twelve or twelve-and-a-half, with interlaced scanning, and 180 lines per frame.

So many things are supposed to be done that I cannot assure you that this is perfectly true, but it might be of some interest to you to know what is to be heard unofficially.

I will have further indications later. Hoping this will be useful to you.

AMATEUR (Paris).

SIR,

On Friday, February 7, I wrote to you to say that I heard from one of the television engineers that the new station of Paris will be at Yssy les Moulinaux.

Yesterday I was introduced to the company which is making the experiments for our national television.

There I heard that the new transmitter would be under the Eiffel Tower, 180 lines 25 frames, and that they will try interlaced scanning at twice 25 pictures per second.

I saw the reception of the Eiffel Tower at something like seven kilometres, aerial a vertical doublet, the receiver a superhet. The picture was rather blurred and not very stable because of static. There was, however, plenty of detail most of the time; it was all direct pick-up, scenes, singing and dancing on the stage, etc.

I also saw in the laboratories the transmission and reception of cinema films and reception on the biggest Cossor tube, transmission by disc scanning. They showed me moving drawings, ice skating, the usual cinema scenes, and a man speaking at the mike.

The results were amazing, absolute stability (stability better than Pathé Baby) very clear and good contrasts. The picture size was about 8 ins. by 10 ins. With moving drawings the vertical lines were blurred but not more than about 1/30 of an inch. At one and a half yards distance the blurring was not noticeable.

I must tell you that I am very enthusiastic about your periodical. I see others, but they are not to be compared with yours, because you give very good and interesting technical articles and good patent analysis.

"AMATEUR" (Paris).

5-metre Transmission

SIR,

Mr. Parsons' letter in the February issue calls for some comment.

The report of the five-metre contact between G6PU and G2PB is inaccurate because Mr. Parsons was unscientific enough to proclaim the matter to the public before he had a written confirmation from G2PB. If 2PB was smart enough to hoax a large number of 40-metre amateur telephony stations into thinking he was genuine, he may have carried the hoax further.

On Saturday, December 14, I heard G2PB working G6AU, of London, and as soon as their contact was over, I called G2PB. Guessing he was a pirate by his queer objections to giving his address, I asked him certain questions, which although I tried to make as natural as possible, probably put the pirate on his guard

(Continued on page 168.)

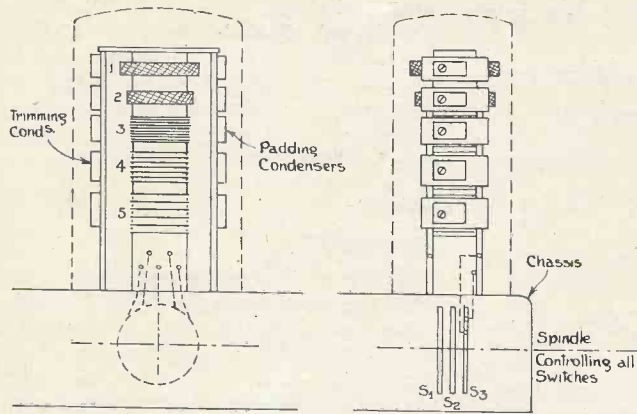

(Above) Fig. 9.—Arrangement of padding and trimming condenser for switched coil assembly. (Right) Fig. 10.—Complete circuit diagram for all-wave receiver with signal frequency and oscillator circuits.

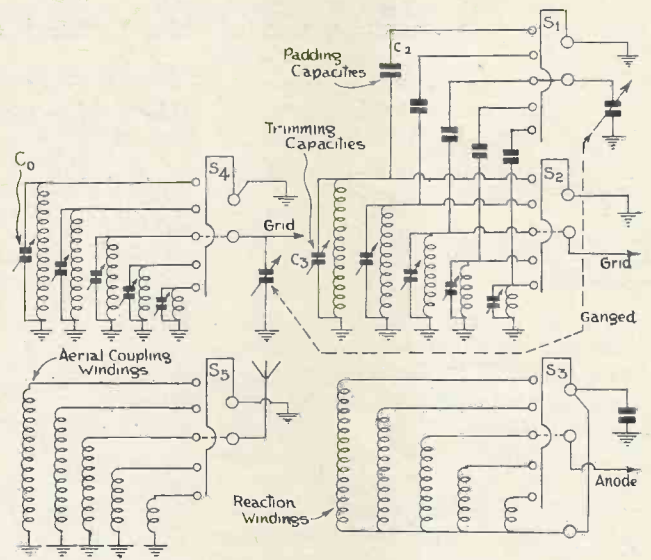

SIGNAL FREQUENCY CIRCUIT

OSCILLATOR CIRCUIT

The final circuit diagram for signal and oscillator units then becomes as Fig. 10. The reaction and aerial coupling windings may then be

switched by similar switches to those shown in the diagram above (Fig. 10). The number of turns for these windings is best determined experiment-

ally, but may be $1/5$ for the aerial coupling and $1/2$ for the oscillator reaction winding of the turns on the corresponding tuned coil.

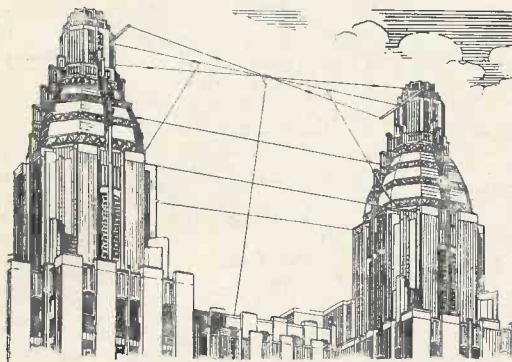

These are the aeriels used for reception at the Waldorf Astoria Hotel in New York.

Picking Up Transatlantic Relays

By Hon. Michael Norton

away are picked up and re-broadcast with so little trouble.

The first of these transmissions I picked up was the rehearsal of a commemorative broadcast from Newfoundland. After that I heard the arrival in New York of the French liner "Normandie."

It was then that I noticed how the special transmission directed towards France came in better than the standard transmission from America. The reason, of course, was the extra power and directional array. On December 20 an excellent transmission was heard on 70 metres. It was part of a variety entertainment from the Radio City Music Hall, and was relayed to listeners in Germany. One relay that can be relied upon comes over at about 7 p.m. every Sunday evening. It is called the "Magic Key," and is sponsored by the National Broadcasting Company. The programme is sent out through its normal short-wave transmitters but, in addition, is sent to Europe by a special high-power link.

The programme opens with the announcer saying "The Magic Key of R.C.A. turns and opens the doors of space, and we take you now to . . ." and then follows some interesting relay.

Towards the end of December one of the items relayed was Segovia, the guitarist playing at a Music Hall in Madrid. During the preceding items, one could hear the R.C.A. engineers in charge of the relays interrupting with "Ten Minutes to Go, Madrid," and "Cut the announcement short." When Segovia started playing the programme could also be picked up from the Spanish station EAQ on 30 metres. During one of the "Magic Key" programmes I heard a complete relay from Germany via one of the short-wave stations at Zeesen, which was then re-transmitted back again to Europe so that by the time I heard it, it had travelled over 7,000 miles.

The little principality of Liechtenstein sent a special programme to America via the short-wave station at Geneva. During the rehearsal engineers appeared to say "Something's overloading Geneva." The actual programme was ultimately transmitted on medium waves via the N.B.C. station WBZ in Boston. The connecting link with Europe being WQP, Rocky Point.

The B.B.C. send out quite a number of special programmes which are never heard in England. One of the most popular of these was Jack Hylton who, although he was playing in the London studio, was only heard on short-waves, as the programme was for the benefit of the American and colonial listeners.

DRESS rehearsals of transatlantic relays now provide yet another source of entertainment for the short-wave listener. Quite regularly during the year broadcasting bodies on both sides of the Atlantic arrange an interchange of programmes for re-broadcasting on medium waves. These relays have been made possible by short waves for high power stations with directional aeriels are used solely for this purpose.

Consequently it needs only the simplest of short-wave sets to pick up these programmes. Generally speaking, the American commercial short-wave broadcasters are greater in strength than the programme stations such as W2XAD. Rehearsals of programmes to take place later in the day are radiated at all odd times, and it is these rehearsals that give one an insight into how programmes originating up to 10,000 miles

"Dr. Zworykin on the Electron Multiplier."

(Continued from page 154.)

stances of low work function, and the most satisfactory material was found to be oxidised silver, beryllium or zirconium, with a caesium surface layer. For these surfaces a secondary emission of 8 to 10 secondaries per primary has been reached, at a velocity of 400 to 600 volts (The lecturer here showed curves of secondary emission from silver-oxide cathodes.)

As will be seen from the curves the secondary emission increases with the increase of voltage, until the peak is reached about 500-600 volts, after which it begins to decrease.

For removing the secondary electrons and focusing on to the next target, either electrostatic or magnetic fields can be used. (The electron multiplier demonstrated by the lecturer at the conclusion of the proceedings was one in which the stream was magnetically focused, and it was shown that by altering the position of the field the number of electrons arriving at the target could be controlled, and with it the degree of amplification of the signal.)

Multiplying tubes of this type can be made to produce very high gains, as the number of stages increase: for example, a magnetically focused multiplier can be made with twelve stages, at an overall gain of several million.

The principal advantage of the electron multiplier over the multiplication obtainable with ordinary valve stages is in the high signal-to-noise ratio. In the ordinary thermionic amplifier, the signal-to-noise ratio is governed by the thermal noise from the coupling impedance between the valves, and in the photocell. In the multiplier the absence of such couplings reduces the noise, which is then only due to the fluctua-

tion of the electrons passing up the tube.

The results of experiments show that a gain in signal-to-noise ratio of 60 to 100 times is obtainable with the multiplier as compared with a thermionic amplifier.

Fig. 3 shows the connections of a multi-stage magnifier. The light is focused on to the electrode 1, and the electrons are successively reflected from the plates 1A, 2, 2A, etc. The field plates 1A, 2, are connected internally, and these potentials are obtained from internal resistances in a similar manner to those of Fig. 1.

A tube of this type, having an output of as much as several amperes per lumen, can be designed, and is not much larger than an ordinary receiving valve. The amplifiers are very stable, and are unaffected by external interference. The amplifying action of the multiplier can be used for generating of oscillations by feed-back of energy or by the use of the negative resistance characteristics of the device. In fact, the secondary emission multiplier will become a serious rival to the thermionic amplifier in many of the fields which the latter has occupied for so long.

At the conclusion of the lecture, Dr. Zworykin demonstrated the use of the electronic multiplier in amplifying a signal from a pick-up to full loudspeaker strength. The absence of background noise on removal of the signal was marked, no hum being audible from the loudspeaker.

Bideford and District Short-wave Society.

Readers interested in short-wave radio in the North Devon area are invited to get in touch with Mr. E. K. Jenson, Secretary of the Bideford and District Short-wave Society, 5 Furzebeam Terrace, East-the-Water, Bideford.

B.T.S.

ACKNOWLEDGED
THE BEST

Produced by Specialists—Preferred by Experts

EXCLUSIVELY SPECIFIED for the
PRE-SELECTOR CONVERTER UNIT



4-PIN COIL FORMERS.
Moulded on low loss high power factor insulating material ... **2/3** each

READY WOUND 4-PIN COILS (illustrated). Formers as above. No. 1 13-26, No. 2 24-52 metres, 4/- each. No. 3 46-96, No. 4 90-190 metres, **16/-** 4/6 each. Set of 4.

PADDING CONDENSER (centre). Employs air-dielectric. Minimum losses are attained by reduction of insulating material. Type U.P.C. ... **3/3** each

TRIMMING CONDENSER (on left). Rigidly constructed, specially designed to eliminate crackle during operation. Type U.T.C. **2/9** each

L.F. CHOKER. Designed to ensure low minimum D.C. resistance and ample inductance. Type L.C.30. **10/6** each

Obtainable from all Dealers. If any difficulty, send direct.

Send 3d. in Stamps for "The SHORT WAVE CONSTRUCTOR" the B.T.S. magazine containing three new S.W. circuits.



BRITISH TELEVISION SUPPLIES LTD

Television and Short Wave Specialists
Faraday House, 8-10, Charing Cross Rd., London, W.C.2
Tem. Bar 0134-5. Grams: Television, Lesquare, London.

OPTICALLY
WORKED
LENSES &
MIRRORS
of all kinds

Our Croydon Factory, producing several million high-grade Ophthalmic Lenses every year, enable keen prices for special Lenses in quantity to be quoted

Gowllands

LIMITED
MORLAND ROAD,
CROYDON.

Telephone: Addiscombe 3011/2.
TRADE ONLY SUPPLIED.

BINDING CASES
AND INDEXES
for 1935 are now available.
Price 2/9 post free.

PIEZO QUARTZ CRYSTALS



1.7mc, 3.5mc, and 7.0mc. Amateur bands

Power Type Standard Type

£1 post free **15/-** post free

Ground to within 5 Kcs. of your specified frequency, and supplied complete with official certificate of frequency.

CRYSTAL HOLDERS—

Type A, Open Electrodes, 4s. 6d. post free.
Type B, Totally enclosed and dustproof, 8s. 6d. post free.

Send a 1½d. stamp to-day, for our new 1936 catalogue of short wave transmitter and receiver components.

THE QUARTZ CRYSTAL CO.,

63 & 71, KINGSTON ROAD, NEW MALDEN, SURREY
Telephone: MALDEN 0334.

Read

"Television

and

Short-wave

World"

Regularly

TELEVISION DEVELOPMENTS

A NEW LARGE DIAMETER TUBE FOR TELEVISION REPRODUCTION

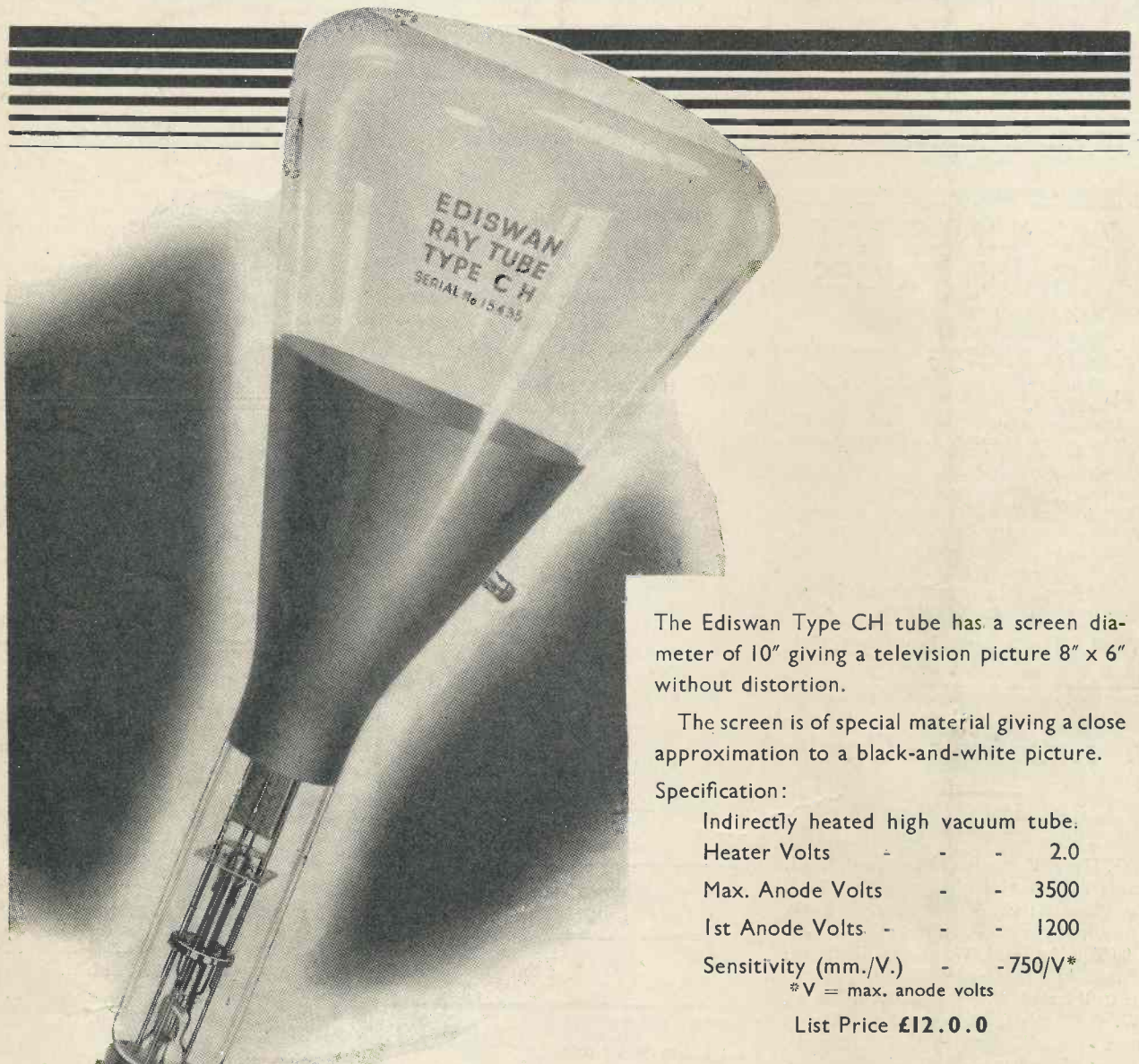

The Ediswan Type CH tube has a screen diameter of 10" giving a television picture 8" x 6" without distortion.

The screen is of special material giving a close approximation to a black-and-white picture.

Specification:

Indirectly heated high vacuum tube.	
Heater Volts	- - - 2.0
Max. Anode Volts	- - 3500
1st Anode Volts	- - - 1200
Sensitivity (mm./V.)	- - 750/V*

*V = max. anode volts

List Price £12.0.0

● We also supply
HIGH VACUUM RECTIFIERS
GAS-FILLED RELAYS
MERCURY VAPOUR RELAYS
for Television Scanning
circuits.

ENTIRELY BRITISH MADE

EDISWAN RADIO VALVES

THE EDISON SWAN ELECTRIC CO. LTD.



155 CHARING CROSS RD., LONDON, W.C.2

R.E.280

USED BY ALL GOVERNMENT DEPARTMENTS