

30-LINE TELEVIEWER COSTING £2 : 2 : 0

# TELEVISION

THE FIRST TELEVISION JOURNAL IN THE WORLD

and

# SHORT-WAVE WORLD

MONTHLY 1/-

MAY, 1935

BERNARD JONES PUBLICATIONS LTD.,  
CHANSITOR HOUSE, CHANCERY LANE,  
LONDON, W.C.2.

## TELEVISION

*Electron Multiplier :  
Amazing New Device*

*Novel Use of a Scanning Disc*

*Recent Developments*

*High-definition Test  
Transmitter*

*240-line Pictures with  
30-line Mirror Drum*

## SHORT WAVES

*Building All-wave Super*

*Push-pull Modulation*

*Heard on the Short Waves*

*Experimental 5-metre  
Transmitter*







*Short-wave World Review*

## GERMAN TELEVIEWER

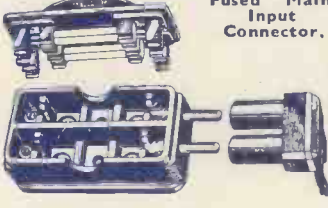

The Check Receiver for the  
Berlin High-definition Transmissions

# For a good job well done Use *Belling-Lee* Connections

<p>Television INDICATIONS</p> <p>SYN MOD</p> <p>ANODE GM</p> <p>X1 X2</p> <p>Y1 Y2</p> <p>A1 A2</p> <p>B1 B2</p>	 <p>Terminal Mount Standard type, 6d. ea. Low-loss " 1/1- 112</p>	 <p>"B" Type Terminal, 6d. each.</p>
	 <p>Single Open Fuseholder, Complete, 9d.</p>	
 <p>3/6 Without Plug and Socket, 2/6</p>	 <p>"Wan derfuse" complete, 1/-</p>	
 <p>Screened Low-loss Valve Top Connection - - - - 1/6d.</p>	 <p>Spade Terminals, 2d. each.</p>	
<p>Write for a copy of the 32-page "RADIO CONNECTIONS" and keep it by you.</p>		 <p>"Bow-Spring" Wander Plugs, 1 1/2d. each.</p>

**BELLING & LEE LTD**  
CAMBRIDGE ARTIFRIAL ROAD, ENFIELD, MIDDX

Mention of "Television and Short-wave World" will ensure prompt attention.

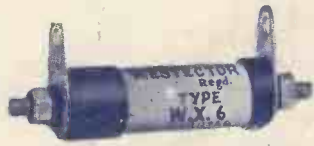

## BETTER THAN A DIODE

For not only does a WX6 Westector possess a linear characteristic, but it is even more simple to use. It has no heater or anode, and can handle high overloads without introducing distortion. A recommended circuit is shown below, and further particulars may be obtained from:—

Dept. T., WESTINGHOUSE BRAKE & SIGNAL CO., LTD. 82 YORK ROAD, KING'S CROSS, LONDON, N.1.

### WX6 WESTECTOR

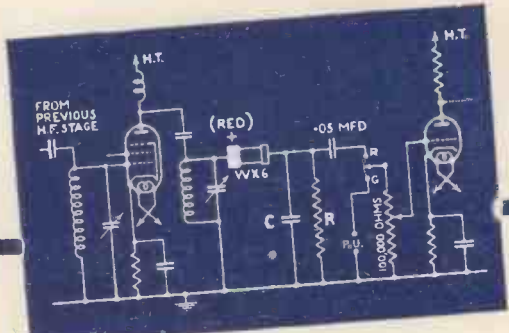

## Mr. REYNER specifies these TUNGSRAM types for his 5 & 7 metre trans- mitters

**5 METRE**  
2-Tungram type 0-15/400  
Price 14/0 each.  
1-Tungram type APP4120  
Price 14/9 each.  
(0-15/400 is the revised type No. of the P4100)

**7 METRE**  
2-Tungram type 0-15/400  
Price 14/0 each.  
2-Tungram type VX2810  
Price 17/6 each.

Expert preference for Tungram valves is again exemplified by Mr. Reyner's exclusive Tungram specifications in these important new transmitters. Their unrivalled efficiency and reliability is made all the more striking by their comparatively low cost. The comprehensive Tungram range includes a number of valves particularly suitable for Television purposes. Complete details will be sent on request.

Illustrated is OQ 70/1000 a highly efficient oscillator for ultra short wave work

# TUNGSRAM

BAR IUM VALVES



## AS IN RADIO— SO IN TELEVISION

A VERY great number of highly skilled radio enthusiasts have turned their attention to Television; they are also confirmed SOUND SALES "FANS." They will agree with us that SOUND SALES Invariably figure exclusively as far as new developments are concerned. To quote just one instance—The first Cathode-Ray Excitor Unit designed by Mr. G. Parr some time ago used the only successful high voltage transformer available at the time made by SOUND SALES. Since then we have supplied the leading Television Companies in the country with 90% of their requirements, and the advent of the "Amateur Band Super Receiver" designed by Mr. K. Jowers substantiates our claim to exclusiveness.

For this receiver we designed a special Mains Transformer, known as type "SW/SUPER" and priced at 25/-.

N.B.—Many people will make this receiver; many people will make transformers which will be offered to you as being "Just as good." They may be, or they may not, but unless you use SOUND SALES you will not find out until it is too late.



**SOUND SALES LIMITED**  
(Contractors to the G.P.O.)  
TREMLETT GROVE WORKS  
JUNCTION ROAD, LONDON N.19.  
Telephone: Archway 1661-2.

## CLIX Predominate!

When it's a question of Chassis Mounting Valveholders—designers invariably turn to CLIX.

They know that the range is the largest—that there are 4-5-7 and 9-pin types available either with or without terminal connections, and, that where short-wave circuits are [employed, CLIX is "the one and only" make of Chassis Mounting Valveholder that is Anti-microphonic—of a design eminently suited to short-wave work and is obtainable in either 4-5 or 7-pin types.

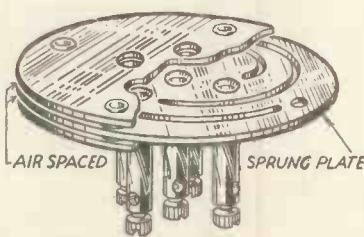

**CLIX**  
"AIRSPRUNG"  
VALVEHOLDERS  
Specified  
for the  
ALL-WAVE SUPER.

4-pin, 11d. 5-pin, 1/-. 7-pin, 1/1.  
Prices are for without terminals.  
Supplied with terminals for 3d. extra

Write for Clix  
Folder "T"

## LECTRO LINX LTD.

79a ROCHESTER ROW, LONDON, S.W.1

## Again . . . The Choice of Critics

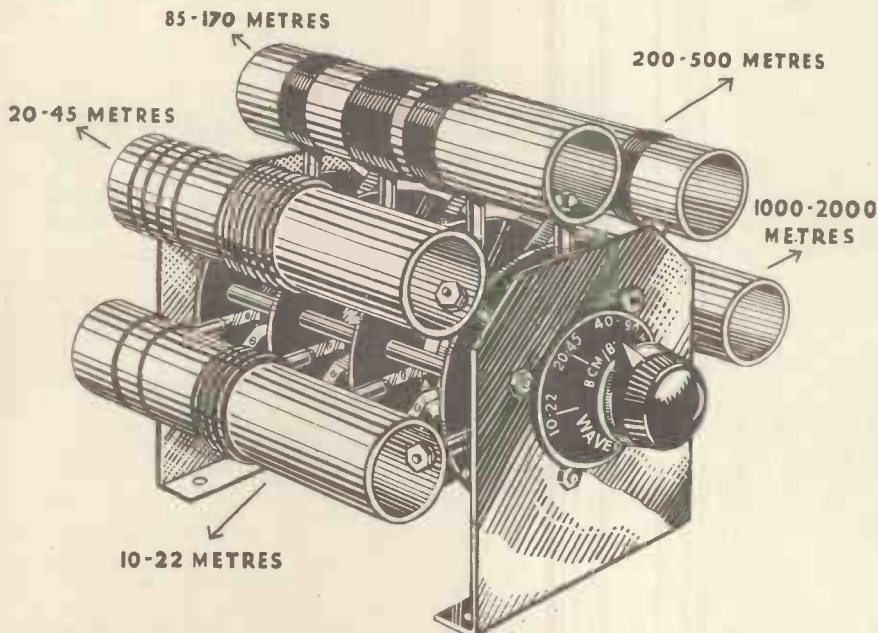

## BULGIN

MULTIPLE SHORT-WAVE COIL CHASSIS  
Specified for the  
ALL-WAVE SUPER

With almost mathematical regularity, the experts choose Bulgin components for inclusion in their circuits. Their latest choice is this Multiple Short Wave Coil Chassis. This chassis carries five coils and has a specially developed self-locating, three-pole five-way switch with snap action. Like all components bearing the name Bulgin, it can be relied upon for sturdy and unflinching service for an indefinite period of time.

List No. S.W.22	Coils for above:—	15/6
List No. S.W.23, 10/22m.	...	each 3/6
List No. S.W.24, 20/45m.	...	
List No. S.W.25, 40/90m.	...	
List No. S.W.26, 85/170m.	...	
List No. S.W.27, 130/240m.	...	
List No. S.W.28, 200/500m.	...	each 4/-
List No. S.W.29, 1000/2000m.	...	each 4/6

COUPON

Please send, post free, 80-page catalogue No. 154. M. I enclose 3d. in stamps.

NAME .....

ADDRESS .....

# BULGIN

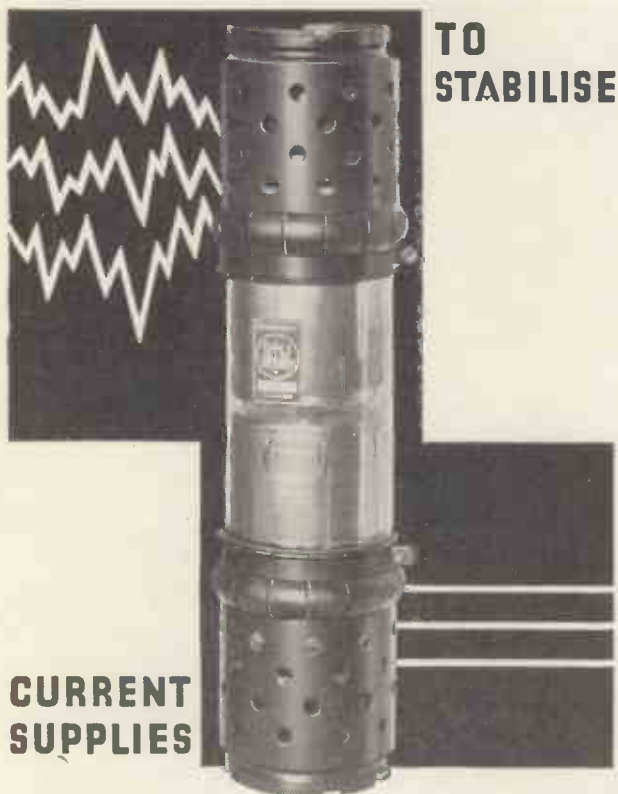

**CURRENT SUPPLIES**

An efficient and convenient method of dispensing with storage batteries or mechanical current supply stabilisers is now available in the Marconi-Stabilovolt glow gap divider.

Marconi-Stabilovolt systems capable of stabilising voltages up to 600 with a maximum current drain of 200 milliamperes are available. A fluctuation of only 1 or 2 per cent. at any condition between full and no load is ensured, and only  $\pm 0.1$  per cent. on supply voltage variations of  $\pm 10$  per cent.

**MARCONI**  
• STABILOVOLT •

Full particulars from :—

**MARCONI'S WIRELESS TELEGRAPH CO., LTD.,** Electra House, Victoria Embankment, London, W.C.2.

**FERRANTI**

**VALVES FOR EVERY RADIO PURPOSE**

Illustrated is VALVE L.P.4. PRICE 16/6

Write for booklet to **FERRANTI LTD.** HOLLINWOOD LANCs.

**BRYCE PRODUCTS**

**RECOMMENDED COMPONENTS**

FOR

**DE LUXE CATHODE-RAY RECEIVER**

- 1—BRYCE Special Astatic Mains Transformer MODEL T2000.
- 1—H.T. Smoothing Choke 100 HY 10 M.A. MODEL T100
- 1—L.T. Smoothing Choke 1 HY 1.3 amps. MODEL T.113.

**PEAK GUARANTEED CONDENSERS**

- 1—8 mfd. 200v. Elec. TYPE C.W.
- 1—50 mfd. 100v. Elec. TYPE D.49.
- 2—1 mfd. 500v. Paper Condensers TYPE C.B.5.
- 1—.1 mfd. 500v. Paper Condensers TYPE C.B.5.
- 1—.01 mfd. 500v. Paper Condensers TYPE C.B.5.

Write for particulars of above to:

**W. ANDREW BRYCE & CO.**  
WOODFIELD WORKS, BURY, LANCs. Phone: 1251.  
London: 3-4, Ashland Place, W.1. Phone: Welbeck 1521.  
Export Agent: W. R. Everett, 63, Queen Victoria St., London, E.C.4.

# TELEVISION

## and SHORT-WAVE WORLD

### Special Features in this Issue

	PAGE
A General-purpose Valve Voltmeter ...	244
Junior 30-line Receiver ...	245
The Electron Multiplier and Mechanical Transmission ...	249
Grid Modulation ...	251
An All-wave Super ...	253
The Short-wave Two ...	256
The ABC of the Cathode-ray Tube ...	257
Push-pull Modulation ...	259
A Novel Use for the Scanning Disc ...	260
Heptodes on Short Waves ...	261
Recent Television Developments ...	263
Distortion in Cathode-ray Images ...	265
Studio and Screen ...	267
Problems of High-definition Mechanical Scanning ...	269
The B.E.R.U. Contests ...	270
A Television Test Transmitter for 7 Metres ...	271
The Circular Polaroscope ...	277
240-line Pictures with a 30-line Mirror Drum ...	281
Experimental 5-metre Transmitter ...	282
Beat-frequency Oscillators ...	283
WgBHT ...	284
Definition and Viewing Distance ...	285
Noise Suppression on the Top Band ...	286
Short-wave Radio World ...	287
De Luxe Cathode-ray Receiver ...	289
The Scophony Television System ...	290
Heard on the Short Waves ...	291
Trade Notes ...	293
Correspondence ...	300

### TELEVISION AND SHORT-WAVE WORLD

#### Proprietors :

BERNARD JONES PUBLICATIONS, LTD.

#### Editor-in-Chief :

BERNARD E. JONES.

#### Editor :

H. CORBISHLEY.

#### Editorial, Advertising and Publishing

#### Offices :

Chansitor House, 38, Chancery Lane,  
London, W.C.2.

Telephones : Holborn 6158, 6159

Telegrams : Beejapee, Holb., London.

Subscription Rates : Post paid to any  
part of the world—3 months, 3/6 ;  
6 months, 6/9 ; 12 months, 13/6.

Published Monthly—1/- net.

(Last Wednesday in every month for  
following month).

Contributions are invited and will be promptly considered. Correspondence should be addressed according to its nature, to the Editor, the Advertisement Manager, or the Publisher, "Television and Short-wave World", Chansitor House, Chancery Lane, London, W.C.2.

## COMMENT OF THE MONTH

### *Putting the House in Order.*

LAST month we pointed out how essential it is that the concerns actually engaged in the development of television should take joint action to enable them to be officially represented when decisions of the future policy of television are being made. It is gratifying to be able to record that the suggestion met with approval and that as a result a meeting has already taken place between some of the influential interests. From one point of view the matter has now become one of extreme urgency, for it has been evident from the attitude of the daily Press of late that there is an anti-television publicity scheme in operation; and there is no organisation to counter it. Due to the pressure that is being brought to bear on the Press entirely contradictory statements have appeared in the same journals within a few days, and while we deplore sensationalism we equally deplore the complete change of front with the inaccuracies that have been presented.

This is only one side of the matter; the Television Advisory Committee does not consist of a body of experts who have devoted years to research work, and obviously its members must need guidance in many matters with which only the technician is fully acquainted. Discrimination of individual interests must be made in the general policy and this could best be done by the joint advice of those who are really *responsible* for television. Details of the most successful systems are now generally known so there is no need for any aloofness on the grounds of secrecy as there has been hitherto. The competition that is to be feared at this stage is from outsiders who are desirous of retarding the progress of television, and this can best be countered by joint action.

### *Commercial Developments.*

IT is gratifying to observe that concurrent with the technical progress that is being made there is also considerable commercial activity connected with television. Several new companies have been formed or are in process of formation, and on another page in this issue we give particulars of the merger between Scophony, Ltd., and the well-known wireless firm of E. K. Cole, Ltd. Most of the larger concerns both here and in Germany have pinned their faith to cathode-ray systems so it is interesting to know that, one at all events, will intensively develop television from the mechanical side.

### *Short-wave Interference*

IT seems that many years will have to elapse before broadcast listeners in this country will all be using receivers having a reasonable degree of selectivity. At the moment a good 50 per cent. of the sets in use are only just capable of separating the medium-wave programmes. In the circumstances it is not surprising that the amateur transmitter, although only on the air for about an hour and a half a day during broadcasting hours, is still a source of annoyance to broadcast listeners. Perhaps in time these listeners will realise that it is their receivers that are at fault and not the amateur transmitting stations spreading.



# A General-purpose Valve-voltmeter

By G5ZJ

*This simple piece of apparatus has so many uses that no up-to-date receiving or transmitting station should be without it. The total cost is low, which solves a problem of the average amateur.*

IT is almost impossible to give accurate reports on small changes in R strength unless some visual means of checking is available. I believe that

measured a meter of the thermionic valve type must be used. It is simple and cheap, so there is no excuse for any station not being so equipped. Although

A small accumulator will last for many months as the discharge is very small indeed. With 16 volts high-tension, apply sufficient bias to reduce anode current to just below cut-off and then directly a signal is applied to the grid of the valve a small D.C. current will be shown on the milliamperemeter. The bias applied to the valve should then be readjusted until the anode current is a reasonable order. Of course, the meter will only give comparative readings, but this is usually enough for general testing.

So as to extend the scope of the meter a variable potentiometer has been connected across the bias battery, for the amount of applied bias can be increased to make the unit less sensitive.

## Calibration

Calibration is fairly simple if an A.C. voltmeter is available. A mains transformer with a low-voltage secondary must be connected across the input terminals of the voltmeter.

The voltage output is then checked and comparative readings on the valve



*This photograph shows the panel of the valve voltmeter with the sensitivity control at the left.*

the minimum change in strength that can be detected by the human ear is about 20 per cent.

Very often when working with weak stations a 20 per cent. change would mean a big alteration at the transmitting end. Looking at it from another angle, I was recently working a local

the scope of the instrument depends to a certain extent on the type of milliamperemeter used, a cheap instrument costing no more than 10s. will prove very satisfactory.

For example, the Sifam meter reading from 0.2 milliamperes will do very well, and as it has quite a wide scale small changes can be read. Actually the valve-meter consists of an anode-bend detector rectifying the speech output from a receiver. It can be connected across either the output or detector valves, although the final valve is preferable owing to the higher current reading. So as to prevent D.C.

voltmeter observed. A power potentiometer is then connected across the secondary of the mains transformer and the voltage output varied until the meter has been completely calibrated.

With a little care readings can be taken at all settings of the bias potentiometer, so making the unit suitable for wide variations in signal input.

It can be used to check variations in input from other stations, to give frequency-response curves, and a multitude of other purposes. A suitable valve for this unit is one having an impedance of between 3,000 and 6,000 ohms with as high a slope as possible.

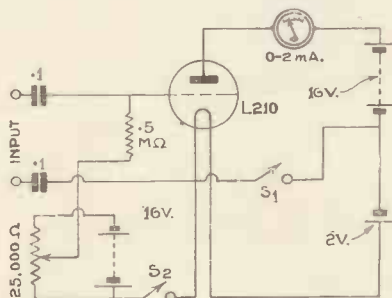

*The circuit arrangement is actually an anode bend detector using a low-impedance triode valve.*

station making some minor alterations. With the first change no difference could be detected by ear, but the valve voltmeter, connected across the loud speaker, registered an increase of 10 per cent. in signal output.

This was duly reported and further tests made. At the end of the transmission the strength of the station under test had gone up, in small steps, by 40 per cent.

Without the valve voltmeter I should not have noticed the initial rise in strength and very probably have sent the operator incorrect information.

Whenever small changes are to be

being applied to the grid of the valve two isolating condensers are connected in circuit. One of the condensers is rather a passenger, but it does prevent possible damage to the valve under all conditions of operation.

The unit can be made completely self-contained if a small accumulator is used. H.T. is obtained from a 16-volt grid-bias battery, while another 16-volt grid-bias battery is used for bias. The voltmeter being described is housed in a wooden box which is screwed to the wall of the transmitting shack and connected permanently across the output terminals of a short-wave receiver.

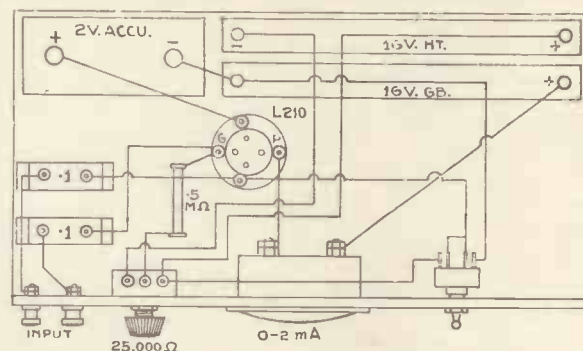

*This is the suggested lay-out for the components which can be modified if desired.*

# THE JUNIOR 30-LINE TELEVIEWER

CHEAP :: SIMPLE  
COMPACT

*This receiver has been designed to enable amateurs to obtain a working knowledge of television at the lowest cost and in the simplest manner. Refinements which may be thought desirable can be added later.*

ONE of the objections the would-be television experimenter has when building his own apparatus is the unwieldy rotating disc which is generally uncased and not very ornamental.

To overcome this and so enable the non-technical constructor to see the type of pictures that are at present being radiated from Brookman's Park, we have designed what we consider to be a neat television re-

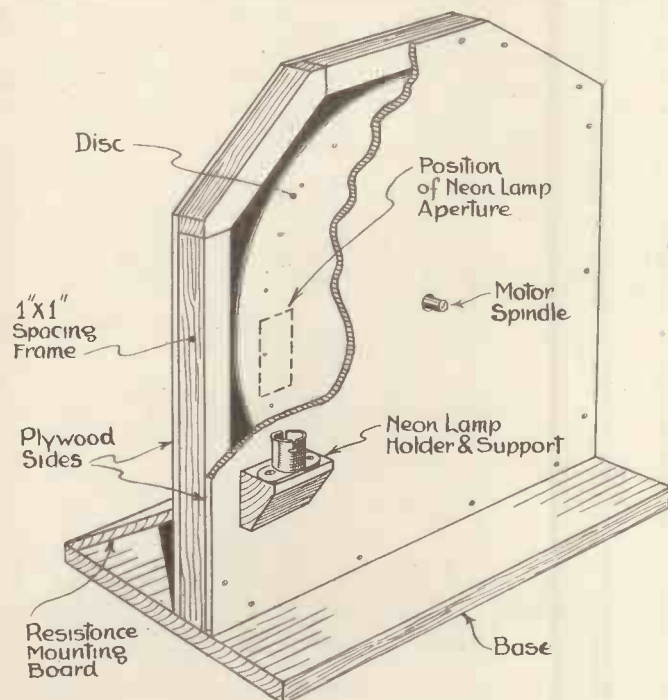

*A cut-away sketch showing the essential parts of the viewer.*

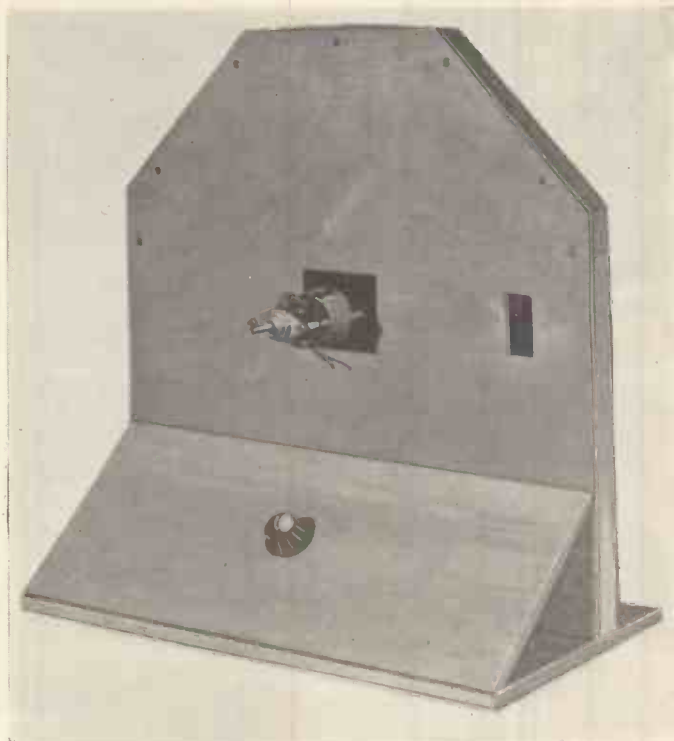

*This photograph shows the complete receiver*

ceiver which more or less overcomes the prejudice to an open disc.

The very minimum of components has been used, so that cost has been kept down to a trifling amount. Any handyman who can make simple pieces of woodwork would only have to buy five components, these being the motor, disc, speed regulator, neon lamp and lamp holders. The total cost need not exceed 42s., and it could be brought even lower than this.

## Making the Case

Altogether ten pieces of wood are required. Two large pieces form the back and front, some  $\frac{1}{2}$ -in. wood for a base, and some  $\frac{3}{8}$ -in. ply as a front panel, which in addition to supporting the disc housing also accommodates the speed regulator. The wood separating the front and back of the disc case is 1 in. square and should be cut to fit—the actual details can be seen from the illustrations. The motor is provided with a square metal plate and is secured to the front of the case by four screws. A hole, approximately  $\frac{3}{4}$  in. diameter, must be cut to take the boss and shaft of the motor and two smaller holes drilled so that two protruding nuts on the motor will sink flush with the woodwork. A small viewing hole has to be cut in both front and back of the woodwork. This hole is approximately 1 in. wide and 2 ins. high. The size is not very important but it should be a little larger than the distance between the first and the last scanning holes. All these details are given in the drawings.

After the viewing hole has been cut on one side of the woodwork an identical hole should be cut on the reverse side.

The motor should then be fitted. Short wood screws will be satisfactory, or alternatively 4 B.A. nuts and

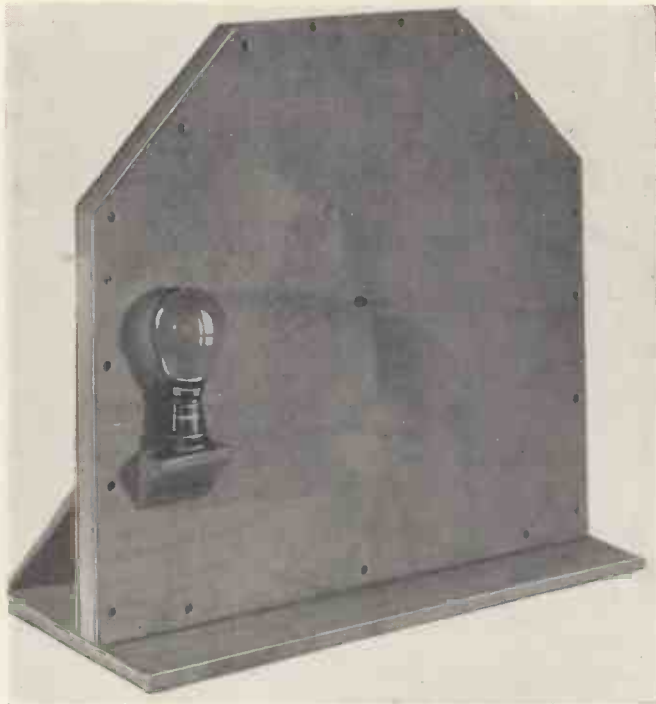

*Photograph of the back of the receiver.*

bolts will do equally well. After the motor has been fitted the disc can be mounted. When this is almost flush with the front board, the disc will have to be very

slightly bent to tighten the grub screw of the boss on to the motor shaft. If this is done carefully it will not distort the disc at all. The reverse side of the disc housing can then be fixed,  $\frac{3}{4}$ -in. wood screws being used for this purpose.

A standard batten holder is used for mounting the neon lamp and this should be arranged so that the lamp comes central with the scanning hole which was previously cut. Two leads from the motor, which by the way is of a special type and can be obtained from the Mervyn Sound and Vision Co., are taken to the front board and out again to the base. One lead goes directly to the supply mains while the other goes to the mains via the variable resistance, which should be mounted on the sloping front panel. Leads from the neon lamp are taken from the batten holder in the usual way for connection to the radio receiver.

### Connection to Receiver

Perhaps the most important part of this television machine is the way it is connected to the radio set. First of all it is essential that the output valve in the radio set be capable of giving at least 1,250 milliwatts, preferably more. This means that you will require either a Pen220A battery-operated pentode running at 175 volts or almost any mains-operated triode or pentode valve. As a general rule commercial receivers using mains-operated pentodes give between 2,500 and 3,500 milliwatts.

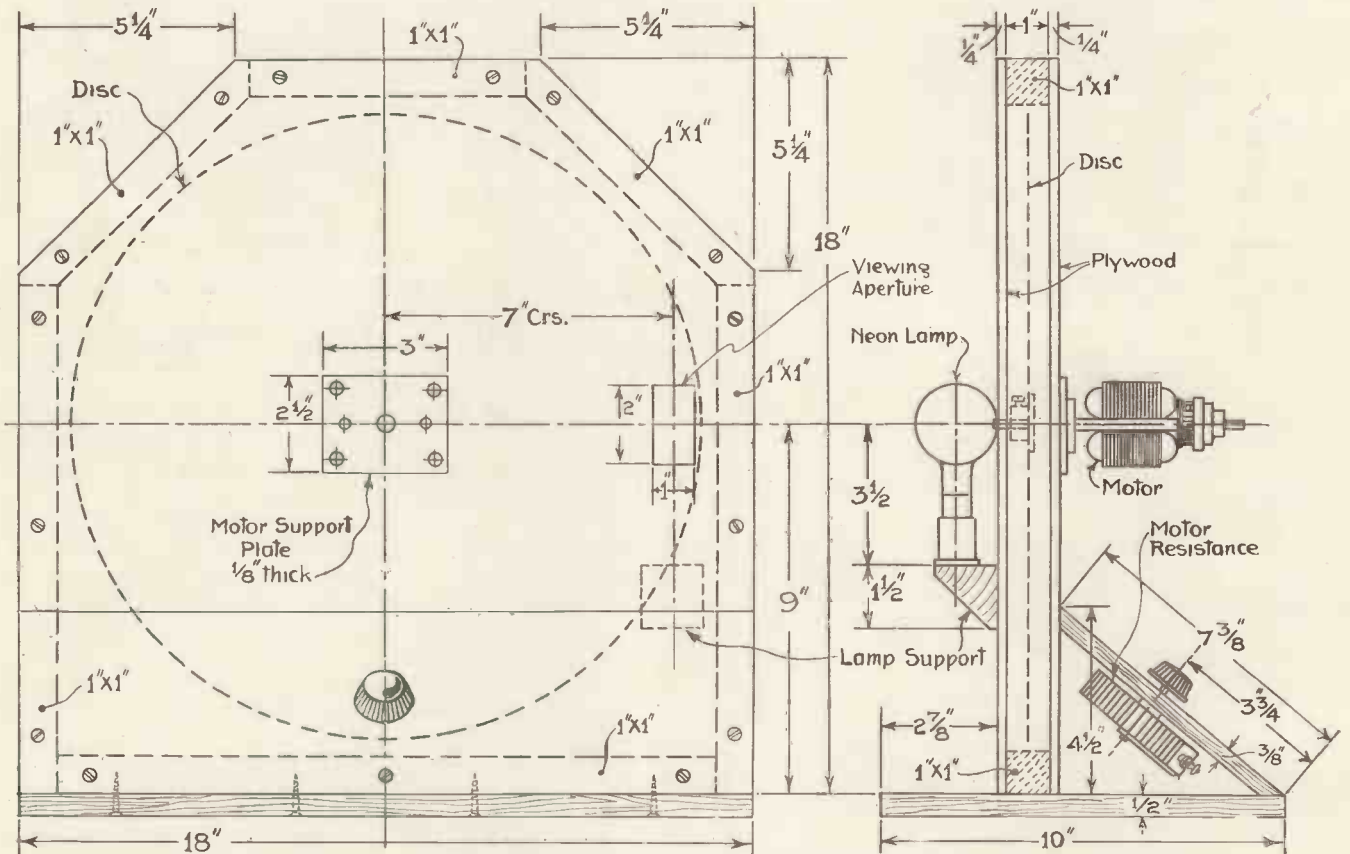

*Fully dimensioned drawings of front and end elevations of the receiver. All the necessary constructional details are quite clear.*





former with the neon lamp and additional polarising voltage in series across the secondary. With this arrangement the loud speaker is always in circuit.

As we have mentioned previously, it can be taken for

particularly to receivers giving a moderately high output from Q.P.P. or class B amplifiers.

To overcome the difficulty of low A.C. output with battery sets it is a good plan to connect two valve

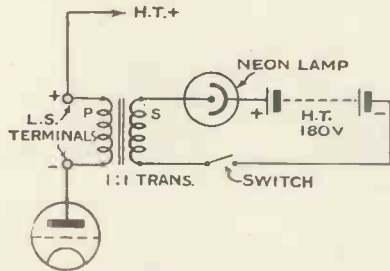

If you have two receivers and can spare one for television, this circuit can be recommended. Simply take off the loud-speaker and connect to neon lamp as indicated.

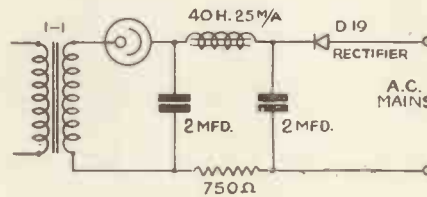

It is an expensive hobby running a neon lamp from dry batteries, so if you have mains laid on use a metal rectifier of the half-type wave. Don't forget the small resistance in series with one side of the supply.

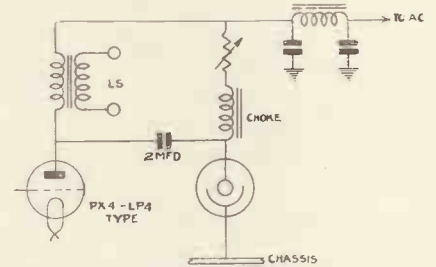

This is a circuit that can be used with the mains receiver. If the applied voltage is too high, the definition will suffer. This can be overcome by the use of the variable resistance.

granted that any modern D.C. or A.C. mains receiver will give sufficient output to feed the neon lamp, while at the same time it can also be assumed that 90 per cent. of the battery receivers will be unsuitable. It applies

holders in parallel externally, simply linking them up with the output valve holders in the receiver by four wires and four plugs. In this way the output from the receiver can be doubled with the minimum of expense.

## American Television Systems

The following details of American television systems are taken from "Electronics," published by the McGraw-Hill Publishing Co. Inc., New York:—

Company.	Type of subject.	Method of scanning.	No. of lines.	No. of frames.	Type of light sensitive device.	Synchron-ization.	Receiving light source and color.	Method of light modulation.	Method of image recreation.	Type of screen.
<b>CATHODE-RAY SYSTEMS.</b>										
Philco Radio and Television	studio film outdoor	cathode-ray "camera tube"	240 to 360	24 to 60	mosaic plate	separate signal	fluorescence (green)	control electrode	cathode-ray tube	fluorescent
RCA-Victor Co.	studio film outdoor	cathode-ray "iconoscope"	240 to 360	24 to 60	mosaic plate	separate signal	fluorescence (green)	control electrode	cathode-ray tube	fluorescent
Television Labs. (P.T. Farnsworth)	studio film outdoor	cathode-ray "image dissector"	240	30	uniform plate	separate signal	fluorescence (green)	control electrode	cathode-tube	fluorescent
J. V. L. Hogan	studio film	mechanical (not disc)	120-60	20-24	photocell	transmitted signal; also power system	glow-lamp white)	direct	mechanical (not disc)	projection and direct fluorescent
		cathode-ray	300-60	20-24-30			fluorescence (green)	control electrode special	cathode-ray tube	

### MECHANICAL-OPTICAL SYSTEMS.

International Television (W. H. Preiss)	studio film	resonant mirror	60-120	24	photocell	transmitted signal plus resonance	incandescent lamp (white)	Kerr cell	resonant mirror	projection
Peck Television (W. H. Peck)	film	mirrored lens disc	60-120	24	photocell	power system	incandescent lamp (white)	Kerr cell	mirrored lens disc	projection

# THE ELECTRON MULTIPLIER AND MECHANICAL TRANSMISSION

By G. BALDWIN BANKS

SINCE the end of the nineteenth century, when Nipkow commenced his experiments which resulted in the invention of the disc which bears his name, methods of scanning have swayed backwards and forwards between mechanical and electronic systems. As far back as 1907, Rosing patented a television system in which a cathode-ray tube was used as a receiver, and about this time Campbell Swinton proposed a form of television apparatus in which a cathode-ray tube was used at both the transmitting and receiving ends. Campbell Swinton's transmitter was in fact a forerunner of the Iconoscope.

Owing to the comparatively un-



Three forms of electron multiplier are shown by this photograph.

vision in 1926. Similar results were obtained in America in the Bell Telephone laboratories. German experimenters used mirror-drums and mirror-screws in addition to the disc.

More recently there has been a return to electronic methods of scanning, owing to vast improvements in the design and manufacture of cathode-ray tubes. The advent of high-definition television has turned the scales in favour of electronic scanning methods. If mechanical methods are to survive on the transmission side it will be necessary to produce some photo-sensitive device which will be many times more efficient than the ordinary photo-cell.

## The Farnsworth Image Dissector

Strangely enough, as a direct consequence of the invention of an electronic scanning device—the Image Dissector—it is probable that a new photo-sensitive cell will be available which may result in a new lease of life for mechanical transmission methods. The image dissector was fully described by Mr. J. C. Wilson in the March issue of TELEVISION AND SHORT-WAVE WORLD. By itself this device is little more efficient than a well-designed mechano-optical system, and Farnsworth admits that the sensitivity for high-definition practice is not adequate for direct scanning of subjects. Normally the am-

plitude of the output signals is below the amplifier noise level. For this reason the unaided dissector tube could be used only for image transmission, when it was possible to project a very bright image on to the photo-sensitive cathode.\*

To overcome these difficulties, Farnsworth developed the "electron multiplier," which depends for its action on secondary emission.

## Secondary Emissions

Under suitable conditions it is found that an electron impacting on a conducting surface may release a number of secondary electrons. The number of secondary electrons released by the impact depends on the velocity of the primary electron and on the physical and chemical nature of the surface. Under normal conditions the number of secondary electrons emitted is about two or three, and rarely exceeds ten. The secondary electrons are emitted in all directions and have low initial velocities.

The secondary emission effect may easily be shown with any triode in which the grid is made more positive than the anode. Fig. 1a shows a circuit by which the phenomenon may be demonstrated. A fixed positive potential is applied to the grid, and the anode current measured for varying values of anode potential. It will be found that as the anode is made positive with respect to the cathode, the anode current rises because more and more electrons pass through the grid and reach the plate. Above a certain voltage, however, the anode current begins to decrease because the velocity of the electrons impacting on the anode is sufficient to release secondary electrons, causing a reverse current from the anode to the more positive grid.

When a certain voltage is reached each primary electron will liberate one secondary electron and no anode current will be registered by the

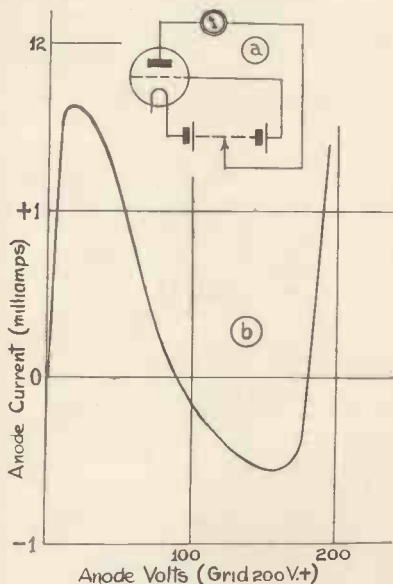

Fig. 1.—(a) Circuit to show secondary emission. (b) Anode current curve for triode with coated anode.

advanced state of contemporary technique, these experimenters met with little success. Other experimenters returned to mechanical methods, and Baird, using the Nipkow disc, accomplished true tele-



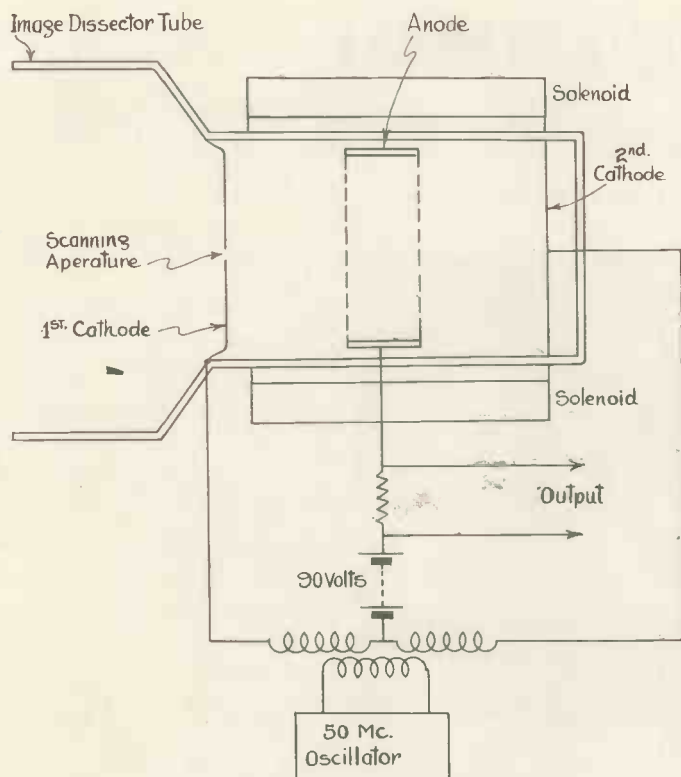

Fig. 2.—Electron multiplier for use with image dissector tube.

meter. Further increase in anode voltage may result in more secondary than primary electrons and the meter will show that the anode current is flowing in the opposite direction. These effects are shown in Fig. 1b in which the data were obtained with a triode having an anode which had been treated with caesium. It will be noticed that above 150 volts the anode current begins to rise again owing to the fact that the potential of the anode is approaching that of the grid, causing it to take an increasing share of the electrons.

### Secondary-emitting Materials

As previously stated, secondary emission depends greatly on the physical and chemical properties of the surface. The effect of the chemical constitution is concerned with the *work function* of the elements of which it is composed. All conductors contain a great number of free electrons which are able to move about in the metal. To enable an electron to leave the surface of a conductor work has to be done in overcoming the attraction between the metal and the electron, and this quantity is different for each substance. The work function of an element is

defined as the work done in causing unit charge to leave the surface, and is usually expressed in volts. The following table\* gives the work function of various elements. It will be seen that caesium has a comparatively low work function and for this reason it is very suitable as an emitter of secondary electrons.

Element.	Work function (volts)
Caesium	1.81
Calcium	2.24
Nickel	2.7
Thorium	3.35
Molybdenum	4.44
Tungsten	4.52
Platinum	6.27

In passing it may be mentioned that although the voltages given for the various work functions are only a few volts, it should be understood that the attraction of a metal for an electron must take place within a very short distance—a few Angstroms†—from the surface. Assuming that in the case of platinum the linking distance is ten Angstroms, then the field required to remove an electron would be .627 volt per Angstrom or over 60 million volts per centimetre. From the physical point of view a highly-polished sur-

\* Dushman: "Electronic Emission." Reviews of Modern Physics. 2. 394. 1930.  
† One Angstrom equals  $10^{-8}$  centimetres.

face emits more electrons than a rough one. Changes of temperature seem to have no effect except so far as such a change may alter the physical character of the surface.

### The Electron Multiplier

We have seen that if the primary electrons have sufficient velocity their impact on a surface will create a greater number of secondary electrons. Farnsworth makes use of this fact to amplify an electron current by causing the stream of electrons to bombard an electrode coated with a film of caesium on silver oxide. The secondary electrons themselves are then caused to impact on another similar surface and this process is repeated a number of times. The very large amplification obtained by this process can be gauged by considering the case where each electron produces 5 electrons for each impact. After only five impacts the magnification would be over 3,000, and in fact an amplification of over  $5 \times 10^7$  times has been obtained in this way.

The method in which the process is carried out may perhaps be better understood by considering the type

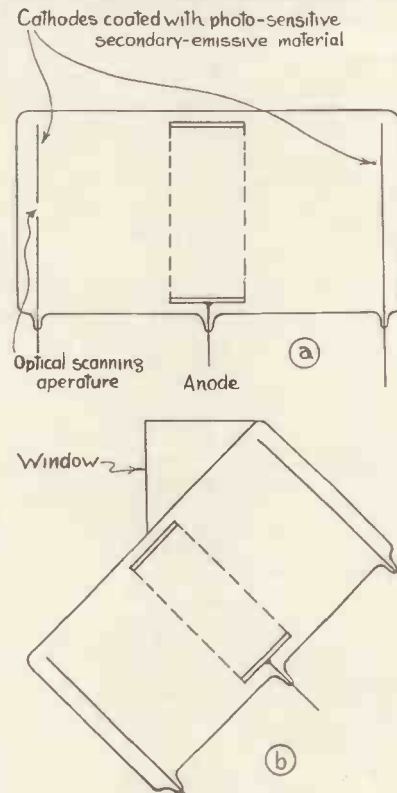

Fig. 3.—Secondary emission photo cells (a) for use with mirror-drum transmitter, (b) for use with disc receiver.

(Continued on page 252)

# Grid Modulation

By "Radio Engineer."

THE conventional form of choke modulation employed on many amateur phone transmitters demands a modulating valve of approximately the same power rating as the final P.A. stage. In the case of a 50-watt outfit, this implies that the microphone amplifier feeding the modulator valve must supply at

sub-multiple of the desired frequency. Suitable stages of frequency doubling, finally result in a voltage of correct frequency which is fed to the final neutralised power amplifying stage delivering the H.F. energy to the aerial system. It is this final stage which must be examined in order to interpret the general theory of grid modulation.

impedance between grid and filament when rectifying, then the D.C. potential is practically equal to the peak value of the driving voltage. The valve is thus biased negatively, and the drive should be adjusted so that the input is fully loaded.

This may be checked by disconnecting the aerial coupling and adjusting the drive until minimum anode current is obtained when the anode circuit is tuned to resonance.

It is rather dangerous to employ self-biasing systems because a failure of the driving valve will immediately result in zero grid bias on the P.A., which shows up very quickly by terrific overheating of the anode, and possible resultant loss of vacuum in the valve itself. For this reason it is far better to connect a bias battery between the points A and B and to bias the grid negatively with no applied drive, until the anode current is substantially zero. The drive is then increased until no further increase in aerial current is observed when the tuned circuit is at resonance. It is this type of driven P.A. which is particularly amenable to grid modulation.

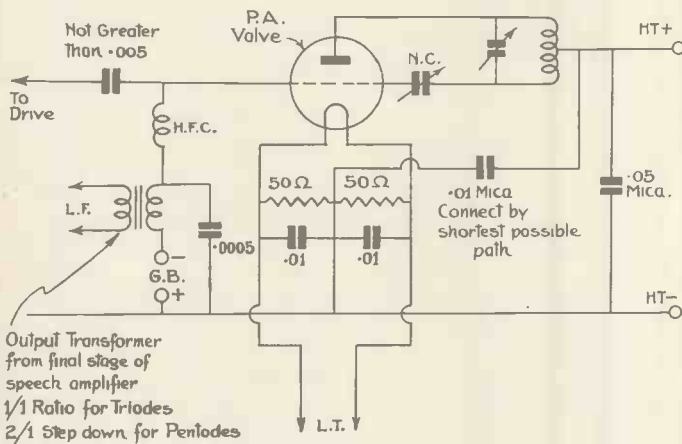

Fig. 1.—This is a typical P.A. circuit in a driven transmitter.

least 5 watts of undistorted speech power. For this reason quite a number of amateurs who might wish to make an occasional phone QSO do not trouble to go to the expense of additional equipment which might easily exceed the cost of the transmitter itself. Some simple and more economical

Fig. 1 represents, in schematic form, the circuit of a final P.A. stage in a driven transmitter. The biasing of the valve is a question of great importance particularly when grid modulation is contemplated. For ordinary transmission, where the P.A. is keyed, the connections from A to B may be a grid leak, because the necessary bias is derived from the valve itself. The mechanism of this self-biasing effect is simple; the driving voltage is rectified by the grid current characteristic of the P.A. valve and a mean D.C. voltage is thus set up across the leak, its magnitude depending upon the peak value of the driving voltage and the value of the grid leak. If this latter value is large compared with the mean effective

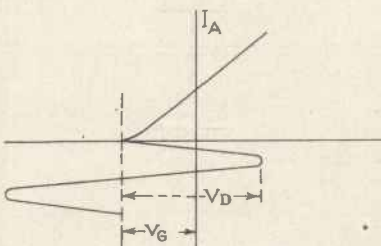

Fig. 2.—Here is the  $I_a/V_g$  characteristics of a final P.A. stage biases to cut off.

form of modulating system is very desirable and, providing the speech quality and modulation depth are good, a certain loss in power efficiency is tolerable. Grid modulation is a very useful alternative, therefore, to the more classical forms of choke or series modulation, and, providing due precautions are taken with the circuit technique involved, the results are surprisingly good. In a driven type of transmitter a crystal oscillator is employed, working at some

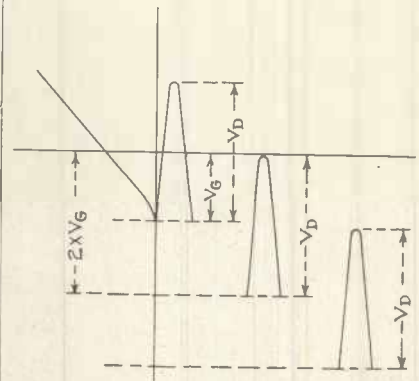

Fig. 3.—These are the three half waves mentioned in connection with the modulation.

Fig. 2 shows the  $I_a/V_g$  characteristic of a final P.A. stage which is biased to cut off by  $V_g$  negative volts with respect to the filament.

The peak value  $V_d$  of the driving voltage must firstly be carefully adjusted to its optimum value beyond which no further output results. This is an extremely important point and must be strictly adhered to when making the adjustments for speech modulation of the stage. If an aerial ammeter is employed, the next step is to increase the P.A. bias until the aerial current is halved. If no meter is available a fairly accurate equivalent result will be

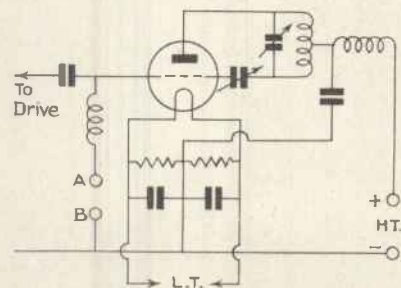

Fig. 4.—With this circuit in use the P.A. will operate down to 10 metres with grid modulation.



obtained by doubling the bias, always providing the optimum drive has been initially obtained. The process of modulation now merely consists of swinging the bias in alternate directions, so that in a positive direction the initial bias is reached, and in a negative direction the drive does not operate upon the valve characteristic at all.

The three half-waves of Fig. 3 show clearly the process involved.

The centre half-wave is the position of the driving voltage  $V_d$  for the carrier only. In the high-hand half-wave

a positive modulation peak at 100 per cent. modulation depth has been produced. Finally the left-hand wave is a negative modulation peak at 100 per cent. depth. The carrier has thus been changed over the complete cycle of modulation, from zero to twice its quiescent value, which represents a linear 100 per cent. modulation.

Naturally, the modulation of the grid bias (which it really is) may be achieved by using speech potential derived from a microphone and an appropriate amplifier. The speech power required may

be roughly estimated as about one-tenth of the D.C. input power to the P.A. On a 10-watt transmitter, any small mains power valve is adequate, and the degree of amplification which precede it is naturally determined by the sensitivity of the microphone employed. With most carbon granule inset type of instruments a single high magnification stage preceding the audio-power valve should be ample.

Fig. 4 shows the necessary connections involved round the P.A. stage, and will be suitable for all amateur bands down to 10 metres.

### "The Electron Multiplier and Mechanical Scanning."

(Continued from page 250.)

of electron multiplier designed to work in conjunction with the image dissector tube. The construction of the multiplier which is built on to the image dissector itself—as a sort of annexe—the whole thing being evacuated, is illustrated in Fig. 2. The weak stream of electrons from the dissector tube pass through the scanning aperture in the first cathode and are accelerated towards the ring-shaped anode by a potential of 60 to 90 volts. A powerful magnetic field due to a current-carrying solenoid wound round the tube, prevents the electrons from reaching the anode, causing them to move in a direction parallel to the axis of the tube.

Under ordinary circumstances the electrons would not reach the second cathode, the attraction of the anode acting in the opposite direction once they pass the centre of the tube. In order to cause the electrons to travel backwards and forwards between the cathodes, a radio frequency of about 50 megacycles is applied to the latter. By adjusting the amplitude of the R.F. it can be arranged that the electrons make one traverse across the tube during one half cycle. As the cathodes have a coating of caesium a considerable increase in the number of electrons results from each traversal. The magnified output is taken off from across the anode resistance.

It will be readily understood that if this magnifying process were allowed to carry on unchecked a saturation point would be reached, or the tube might even be destroyed. In this case the final current would give no indication of the value of the original electron current. For this reason it is necessary to stop the action—after a certain number of traversals have taken place—before the limiting current is reached. This

may be accomplished by introducing an interrupting frequency which serves to check the action periodically in a manner somewhat similar to the action of the quenching frequency in a super-regenerative receiver. The anode current is then directly proportional to the initiating electron current.

### Application to Mechanical Systems

So successful was the addition of the multiplier to the image dissector that it was found possible to increase the output of the latter three or four thousand times without any increase in noise level. There seems to be no reason why a photo-cell, embodying the electron multiplying principle, should not be adapted to mechanical scanners. If the great amplification claimed for the device is realisable, high-definition scanning of direct subjects by disc or mirror-drum systems would be quite possible. A secondary emission magnifying photo-cell of the type shown in Fig. 3a would be suitable for use with

mirror-drum or lensed-disc systems.

A modified form, Fig. 3b, could easily be evolved for Nipkow disc arrangements. This will differ from the electron multiplier just described in so much that light is admitted instead of a stream of electrons. As the caesium-coated cathodes are photo-sensitive as well as secondary emitters the light will cause electrons to be thrown off from them. These constitute the primary electron current which is magnified by the process previously described. Owing to the great sensitivity of this new photo-electric device it would be possible to make the moving parts of a mechanical system quite small so that the whole camera would be compact and easy to manipulate. This reduction in size would mean that very little driving power would be required. It is possible that a mechanically-operated television camera will be evolved which will be more simple to operate than the electronic scanning cameras, which require somewhat complicated scanning circuits to control them.

### Television Scanning Technique and X-ray Diagnosis

The difficulties involved in X-ray diagnosis are said to be greatly reduced by the invention of a three-colour reproduction process which permits X-ray pictures to be transmitted by wire. Luther G. Simjian, former head of the photographic department of the Yale Medical School, developed the process by using the well-known scanning technique used in the mechanical systems of television.

The patient undergoing the examination is placed between the X-ray tube and a fluorescent screen in the usual manner. The image appearing on the screen is scanned by a lead disc containing holes arranged in a

spiral about its circumference. The light which passes these holes is allowed to fall simultaneously upon three photo-cells. These cells are fitted with special filters, the first cell responding to the portions of the picture containing considerable light, the second to portions containing a medium amount of light, and the third to the dark portions of the picture.

The output of the photo-cells, after amplification, is used to actuate gaseous discharge lamps of three different colours. The image is then recreated by a second disc, and the three colour elements combined. By the use of telephone lines between the scanning equipment and the receiving equipment, the image may be sent to various hospitals for diagnosis.—*Electronics*.



MAY, 1935

# An All-wave Super

*This receiver is a stepping stage between the very simple straight set and the somewhat complicated S.S. Super. It has been designed by Kenneth Jowers for use on several amateur bands but has the added advantage that it will function on medium and long waves if necessary.*



*Both the cabinet for the receiver and the cabinet for the power pack match up. They have been arranged to fit together one above the other.*

**M**OST amateurs know that a super-het that will give optimum results on the amateur bands has to be designed in a different way to an all-wave super for all normal amateur and commercial wavebands. With this receiver, I have combined the advantages of a highly efficient amateur-band super with the requirements of the ordinary listener who wishes to hear the London Regional programmes, for example, in addition to the more popular commercial short-wave broadcasts.

The receiver has been designed more or less around the new Bulgun tuner, which will become very popular in amateur circles. Even though the hypercritical may consider that an all-wave tuner is not satisfactory, in this

unit the losses have been kept to a very low minimum so that on 20-metres signal attenuation is negligible as compared with an ordinary plug-in coil.

This tuner has been arranged to take five coils, four of them always being completely out of circuit. There are no dead-end effects. Amateurs will immediately realise that the coils can be modified if necessary to cover 10-, 20-, 40-, 80- and 160-metre bands or by leaving out one or two of the bands not required for medium and long wavebands.

My particular requirements call for reception on 20, 40, 80 and 160 metres, leaving one coil spare. The spare contacts are utilised by the long-wave coil so the National and other interesting long-wave programmes can be received.

The coils as supplied are designed to cover wavelengths between 10 and 22, 20 and 45, 40 and 90 metres and the usual medium- and long-wave broadcasting.

## Tuning Range

These coils are then suitable for amateur and commercial reception without alteration, but I noticed that by re-winding the coils so that the required wavebands came in the middle of the band-spread condenser, there was decided increase in signal strength. This suggestion is only made for serious amateur listeners. The ordinary programme listener will not find it necessary to make any alteration.

Some readers may criticise the coil unit being fitted so that the control knob is at the back of the cabinet. After weighing up the advantages and disadvantages of fitting it to the front I came to the conclusion that as the amateur listener would probably use one waveband for two or three hours at a stretch the continual use of the wavechange switch would not be necessary.

First of all, I do want to stress that this receiver is not intended to rival an S.S. Super with a pre-H.F. stage and all the other refinements, but it will be a distinct step-up in the right direction for a large number of amateur stations.

Although amateurs speak rather glibly of making up multi-valve superhets, some of them are finding that, simple as they are, freak arrangements do not always turn out satisfactorily.

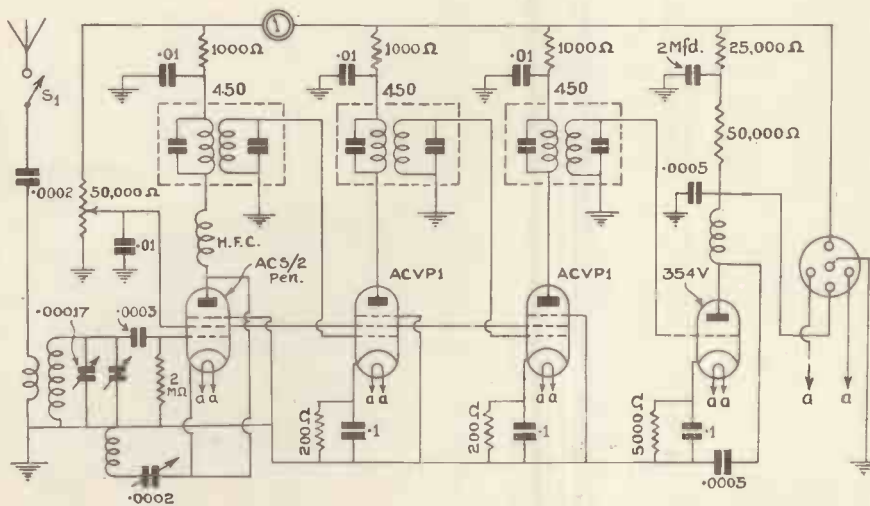

*The circuit of the receiver section has been kept separate from the L.F. section and the power pack.*

In such circumstances, this super-het will make an extraordinary difference to the number of stations worked, for it is simple to operate, cannot possibly fail to function through lack of experience, and is quite within the capabilities of the constructors who have not before tackled a super-het receiver.

**Circuit Arrangements**

Now for the design. The first valve is a fixed-grid base high-frequency pentode working as an autodyne detector-oscillator. It gives very satisfactory results without complications, and in the event of any trouble arising it is simply checked up for oscillation. The two intermediate-frequency stages use AC/VP<sub>1</sub> high-frequency pentodes with a variable grid base, but these have been biased so as to widen the grid base and, at the same time, keep sensitivity to maximum. The intermediate-frequency coils are tuned to 450 kc., for this frequency gives excellent stage gain with complete stability.

Although a leaky-grid second detector is perhaps more sensitive, an anode-bend detector is often more satisfactory, and that is so in this receiver. That comprises the receiver itself. The output stage and power pack have been combined on a separate chassis and are coupled to the receiver by means of a five-way cable. The idea behind this is that in the near future if other receivers are designed there will not be any need to alter the output stage or to buy any new components for that section. In fact, several receivers can be constructed, all working from the same power pack and the same output stage. This results in distinct saving in space and in construction costs. In the future I intend to design every receiver so that it can be plugged into this standard amplifier and power pack, all receivers terminating at the second detector stage.

Actually, the second chassis houses

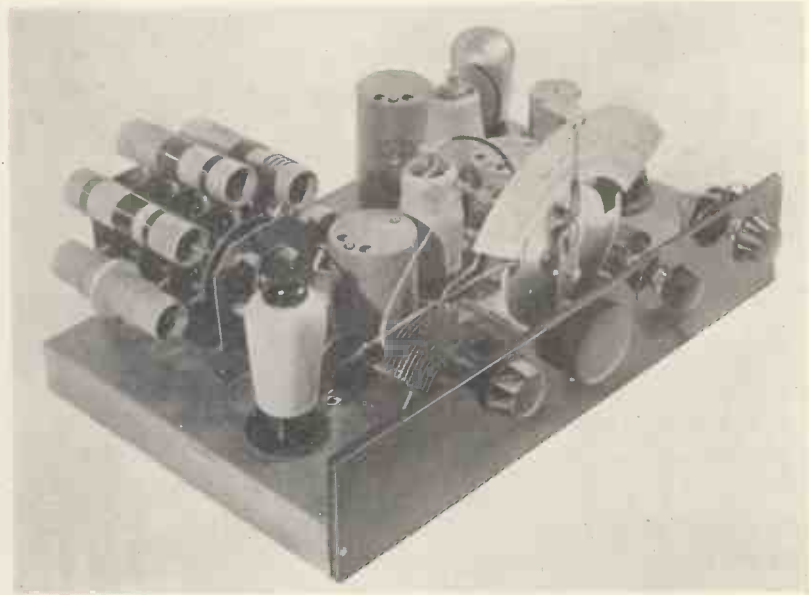

Here is the receiver chassis. The panel is only a temporary one used to secure the tuning components during testing.

the low-frequency transformer, steep slope output pentode, rectifying valve, two smoothing chokes, all the necessary smoothing condensers, mains transformer and the output choke, so forming a very compact and serviceable unit.

**Building The Receiver**

Construction of the set should not present any difficulties. The baseboard is raised approximately one inch, so all the unimportant wiring can be kept out of sight. The top of the chassis is lined with zinc. This is the first time that I have used this metal for screening, but it is a distinct advantage over aluminium, for all negative connections can be soldered to it. A small

piece of ebonite the length of the baseboard and 3½ inches in height will be required until the preliminary tests have been made. This panel is used to hold the tuning dial, master tuning

The main tuning condenser is actually a .00025-mfd. Jackson Popular Log which the makers have double-spaced, giving a capacity of approximately .00017 mfd. In normal circumstances, this condenser is left set at zero capacity, for the band-spread condenser will spread the amateur bands over 100 degrees.

When other bands are required, the wavelength range of the receiver can be increased by varying the tuning on the major condenser, the idea being that the receiver is tuned to almost the required wavelength by means of the larger capacity condenser, tuning after that being done with the band-spread condenser. The volume control takes the form of a variable potentiometer supplying voltage to the screening grids of the first three valves. In addition to this, where constructors have built the receiver in rather a hazy fashion, probably causing instability, this control will be invaluable in stabilising the intermediate-frequency stages.

A milliamp-meter has been connected in the anode circuit of the first detector valve as well as in the screen circuit, the idea of reading the screen current as well as the detector anode current is because at certain settings of the control the anode current is inclined to rise rather sharply.

Several transmitting amateurs have pointed out that in confined spaces, that is, where the receiving and transmitting aerials are inclined to be rather close together, when the receiving set

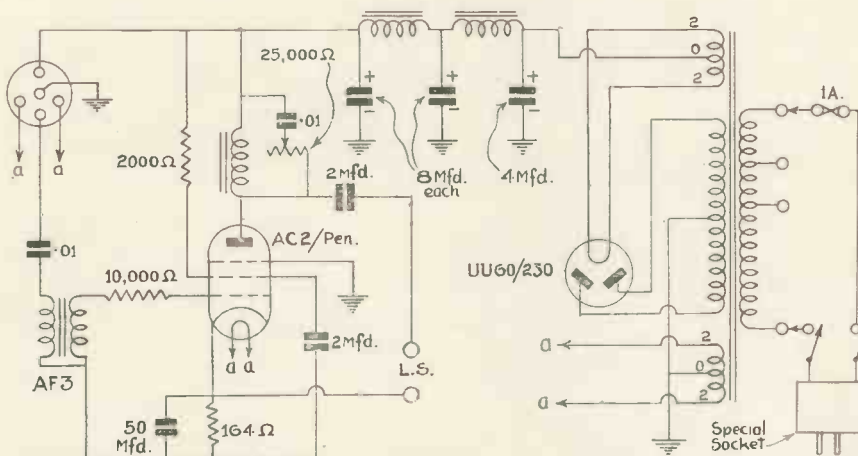

This section of the circuit is entirely self-contained. It gives 3,400 milliwatts output with only a moderate input. The power pack gives 250 volts H.T. at 60 milliamperes.

is tuned to the same waveband as the transmitter there will be a serious attenuation of radiation. To overcome this, a switch has been connected in series with the aerial lead so the aerial circuit can be broken if necessary.

In the amplifying section, variable tone correction is across the output choke. This does help to reduce interference and static. It cannot be cut completely out of the circuit, but in the zero position it has practically no cut-off effect.

### Good Performance

Owing to the very complete smoothing, head-phones can be used if required, but as a general rule the receiver will bring in most of the worth-while stations at good strength. I have often found that if a station is not decipherable on the loud-speaker no material improvement is noticed when headphones are used.

On the top band, unless the aerial was kept to a reasonable length, the London Regional and National stations were inclined to break through owing to there not being any pre-detector high-frequency stage. In my locality this does not cause any damage, but where a harmonic is likely to interfere with a local amateur station a simple wave trap will overcome the difficulty. 80 metres provided reception of several W-stations, which shows that the range of the receiver is well up to standard. While quite a number of stations on the 40-metre band could not be separated, incidentally what receiver will separate them? Several DX stations were heard at good strength.

Canary Isles, Morocco, and, of



Most of the wiring is point to point. This is most essential on the higher frequencies. Keep the connecting wires short.

course, hosts of ZL's and VK's were received at different times. Those interested in the reception of broadcast stations should make a special note that W3ZAL on its 16-metre channel was heard every afternoon for one week on a loud-speaker. Stations on the 19- and 25-metre channel were also tuned in to give 2 watts output.

On the broadcast band second-channel interference is inclined to be troublesome, but 20 or 30 stations can always be received, while on the long waves 6 stations are generally received.

I am of the opinion that this receiver will suit the requirements of many

amateurs. It is selective, has a low background noise level as compared with some of the large super-hets, and, in addition to receiving broadcast programmes by virtue of its band-spreading, is really suitable for amateur work. It should not entail any difficulty to couple up an untuned high-frequency stage in front of the first detector so as to lessen second-channel interference on the top band, but if the 160-metre band is not of primary importance then the receiver will give excellent results as it stands. At the present moment the receiver is being used with 5ZJ and QSO's have been made with many DX stations.

## COMPONENTS FOR THE ALL-WAVE SUPER

### Receiver Section

#### CHASSIS AND CABINET.

1—special type (Peto-Scott).

#### CONDENSERS, FIXED.

1—0.002-mfd. type tubular (Erie).

1—0.003-mfd. type tubular (Erie).

2—0.005-mfd. type tubular (Erie).

4—0.1-mfd. type tubular (Erie).

3—1-mfd. type tubular (Erie).

1—2-mfd. type 990 (Eddystone).

#### CONDENSERS, VARIABLE.

1—0.0017 mfd. popular log double-spaced (Jackson).

1—0.00015-mfd. type 990 (Eddystone).

1—0.002-mfd. type 957 (Eddystone).

#### COILS.

1—complete set All-wave with holder (Bulgin).

#### CHOKES, HIGH-FREQUENCY.

2—screened all wave type 982 (Eddystone).

#### DIAL.

1—type 970W (Eddystone).

#### HOLDERS, VALVE.

2—five-pin type Air-Sprung (Clix).

3—seven-pin type Air-Sprung (Clix).

#### METER.

1—0.10 milliampere type E66 flush mounting (Sifam).

#### RESISTANCES, FIXED.

1—2-megohm type 1-watt (Erie).

2—200-ohm type 1-watt (Erie).

1—5,000-ohm type 1-watt (Erie).

1—25,000-ohm type 1-watt (Erie).

1—50,000-ohm type 1-watt (Erie).

3—1,000-ohm type 1-watt (Erie).

#### RESISTANCES, VARIABLE.

1—50,000-ohms with long spindle (Reliance).

#### SWITCH.

1—type S01LB (Bulgin).

#### TRANSFORMERS, I.F.

3—type 674 (Eddystone).

#### VALVES.

2—AC/VP1 (met) (Mazda).

1—ACS/2Pen (met) (Mazda).

1—354V (met) (Mullard).

#### TERMINALS.

2—type B marked A and E (Bedding Lee).

#### SUNDRIES.

3—type P41 top cap connectors (Bulgin).

1—type P36 five-pin plug (Bulgin).

### Amplifier Section

#### CHASSIS AND CABINET.

1—special type (Peto-Scott).

#### CONDENSERS, FIXED.

2—0.1-mfd. type tubular (Erie).

1—2-mfd. type B.B. (Dubilier).

1—2-mfd. type 990 (Eddystone).

1—50-mfd. 50-volt working (Franklin).

1—4-mfd. 600-volt working (Franklin).

2—8-mfd. 600-volt working (Franklin).

#### CHOKES, LOW FREQUENCY.

2—L34M (Brian Savage).

1—HT35 (Wearite).

#### RESISTANCES, VARIABLE.

1—25,000-ohm (B.T.S.)

#### SWITCH.

1—DPDT (Wearite).

#### TRANSFORMER, L.F.

1—AF3 (Ferranti).

#### TRANSFORMER, MAINS.

1—special type to specification (Sound Sales).

#### HOLDERS, VALVE.

1—7-pin type Air-sprung (Clix).

2—5-pin type Air-sprung (Clix).

#### RESISTANCES, FIXED.

1—10,000-ohm type 1-watt (Erie).

1—2,000-ohm type 1-watt (Erie).

1—164-ohm type Ohmite (Graham Farish).

#### VALVES.

1—AC2/Pen (Mazda).

1—UU60/250 (Mazda).

#### SUNDRIES.

1—type P36 five-pin plug (Bulgin).

1—special combined fuse-holder and mains plug (Belling-Lee).

1—yard five-way cable (Bulgin).

6—insulated sockets (Clix).

6—insulated plugs (Clix).

#### LOUD SPEAKER.

1—Stentorian Senior (W.B.).

A complete Kit of Parts can be obtained from Peto-Scott, Ltd.



# The Short-wave Two

Here are some further details on the Beginners' Two-valve Receiver described in last month's issue.

WO of the components for this receiver can be home-constructed without special tools or technical knowledge.

As the two components in question can be used in almost every short-wave

suitable for all kinds of short-wave sets in addition to the two-valver described. A piece of paxolin former  $2\frac{1}{2}$  ins. in length and  $\frac{3}{4}$  in. in diameter should be fitted with two 6 B.A. terminals, one at each end, as shown in the sketch.

Wind 150 turns of 36 gauge enamelled-covered wire on the former in simple solenoid fashion. Of course, the enamel covering must carefully be scraped off the ends of the wire before it is anchored down under the terminal head.

## The Coil.

This has a multiplicity of uses. It is suitable for simple straight sets as a grid and reaction coil, or as an oscillator coil in a super-het circuit.

Dig out one of the old valves that has given up the ghost, and remove the base from it. By soaking the base in methylated spirit after a time the base comes off quite easily. Of course the connections to the valve pins must be unsoldered.

Then obtain a piece of paxolin former that will fit into the top of the valve base. If the base is of a particularly odd size it may be better to fix the former to it by means of a 6 B.A. nut and bolt through the side of the former and the valve base.

The number of turns wanted for the different wavelengths are given in the table while the sketch shows quite clearly how the windings are connected. If different wire is used the wavelengths covered by the coils will alter.

We have reproduced here the circuit of the Beginners' Two for in the original circuit reproduced last month a slight variation occurred which although not of a serious nature might cause needless worry to the beginner.

Here is the circuit and it should be coupled with the blueprint reproduced on page 186 of the April issue.

## Number of Elements and Picture Detail.

The human eye is able to see two objects separately, for instance two stars, if the light rays from the stars form an angle of not less than 30 seconds or even one minute. Many eyes require at least  $1\frac{1}{2}$  minutes or  $1/40$  degree. This sharpness extends over a field of view comprised within an angle of about five degrees. The angle of distinct vision is about 24 degrees. For a picture subtending this angle and having a height  $h$ , all those elements  $d$  cm. apart will appear separated for which the ratio  $h/d$  is at least equal to  $24:1/40$  or about 960. Splitting the picture up into more than 960 lines would serve no useful purpose for observers looking at it from a comfortable distance. For television pictures where objects are not seen against a dark background, the number of lines may be appreciably reduced.

A large number of illustrations from magazines were placed at distances at which the details were still recognisable. At a distance which corresponded to 450 lines (when the angle of sharpest vision was assumed to be 3.4 minutes instead of 1.5 minutes) all the pictures were satisfactory, from a distance equivalent to 180 lines about 84 per cent., and with 90 lines 30 per cent.—*Ferns. Tonf.*

## 30-Line Transmissions—Alteration of Time.

In view of the increasing number of sporting broadcasts during the summer, the B.B.C. has decided that the afternoon broadcasts of television are becoming inconvenient. Commencing on April 22, the afternoon broadcast will be transferred to Monday night from 11.15 p.m. until 12 midnight. These times line up with the existing Wednesday evening 30-line transmission.

Readers will appreciate the alteration in time for of late the Saturday afternoon broadcasts have often been curtailed.

Television To-day.—This is a serial publication which is to be issued in about sixteen weekly parts at 1s. each. Judging from the first part the work will be comprehensive and provide a general survey of the subject. The contributors include several well-known names, and the articles are profusely illustrated.

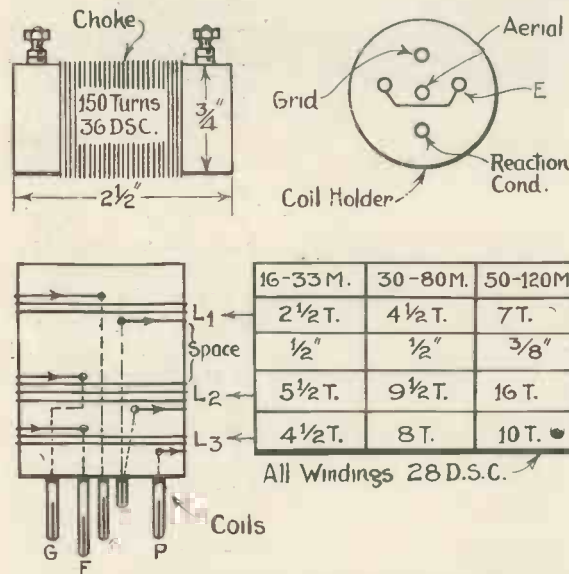

All the necessary details for winding the coils for the Beginner's Two and other simple receivers are given above.

receiver we have devoted a little more space than usual to constructional details.

First of all the H.F. choke. It is

in the table while the sketch shows quite clearly how the windings are connected. If different wire is used the wavelengths covered by the coils will alter.

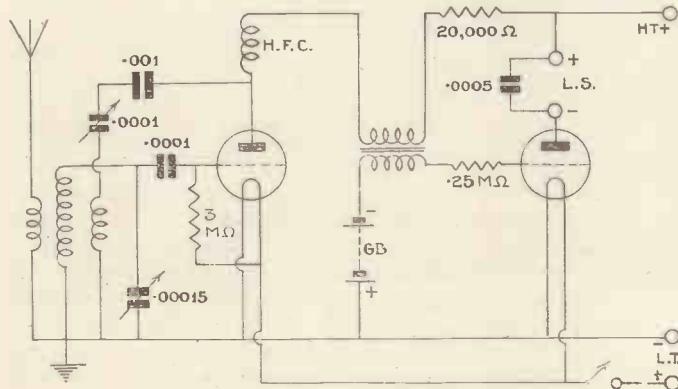

Here is the circuit for the Beginner's Two. There is only one high-tension voltage tapping; it is impossible to short-circuit high-tension to the reaction condenser owing to the use of a series blocking condenser.

## THE A B C OF THE CATHODE-RAY TUBE—II

By G. Parr

*In the first article of this series, published last month, the writer dealt with the theory underlying the flow of the electric current, and showed how electrons could be made to pass out of a piece of metal by the application of heat. The series is written as an introduction to the study of the cathode-ray tube and is specially intended for those who have not yet taken up the fascinating study of television.*

## PUTTING ELECTRONS ON THE SPOT

**T**HERE is one property of the electron which must be considered before we go much further, and that is its charge. We probably already know

this word in connection with accumulators, and in a vague way associate it with connecting the cell to the supply mains and having it replenished with electrical energy.

Unfortunately this idea does not help much in arriving at the meaning of the word. We frequently read that a Grand Jury was charged, but that does not mean that they were connected to the supply mains, fortunately for them. The electron is even more complicated than either the accumulator or the Grand Jury, since it is "negatively charged"! So we have two things to consider—the meaning of "charge" as applied to the electron and the meaning of "negatively." The second word is a little easier to deal with so we will take it first.

### Positive and Negative

The words "positive" and "negative" have been associated with electricity

from the very earliest days in which the only experiments conducted were with glass rods rubbed with cat-skins and similar curious pieces of apparatus. Franklin, in his ingenious theory of electricity, imagined that there was such a thing as an electric "fluid" which became distributed unequally among certain substances when they were "electrified," giving an excess to some and a deficit to others. He first applied the terms "positive" and "negative" to the distribution of this imaginary fluid, calling those substances positive in which there appeared to be an excess.

The terms were, and still are, purely arbitrary, but they have been accepted into the technical language, and we now find it convenient to retain them and to build up certain definitions round them. When electricity graduated from the cat-skin stage through the discoveries of Volta and became a source of light and heat it was thought that the flow of the electric current in a circuit was always in a definite direction, namely, from that terminal of the battery labelled "positive" to that marked "negative." It is just as though the excess of electric "fluid" at the positive terminal of



Fig. 1.—Photograph of the electrode assembly of the cathode-ray tube.

Fig. 2.—Electrons being collected by a metal plate connected to the positive terminal of a battery.

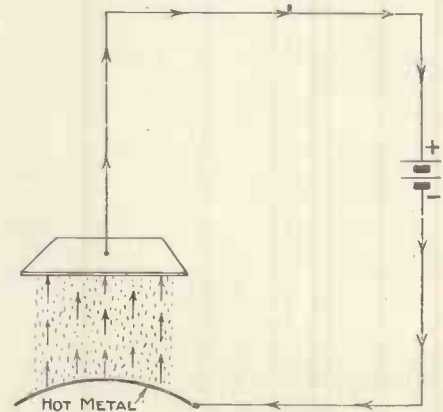

the battery were draining through the circuit to restore the equilibrium at the negative pole.

This idea, although later theories have displaced it, is so firmly rooted that nearly everyone imagines the current to start from the terminal of the battery marked +, or painted red, and to flow to the terminal marked -, painted black. In fact this reasoning was so firmly established that when the electron came along it was judged by the same standards. The early experiments showed that electrons were attracted by wires which were connected to the +, or painted red, and flowed to the terminal marked -, painted black. It was as-

## WHERE ELECTRONS COME FROM

sumed that the electron was associated with the "negative" end of the circuit, and it was said to be a particle of *negative electricity*.

Actually, since the words "positive" and "negative" were applied quite arbitrarily in the first place, we have no more right to say that the electron is negative than positive, but the convention holds good, and it really doesn't matter as long as the idea is clear.

The electron therefore behaves as though it were deficient in electric "fluids," that is, it is attracted to a positively charged electrode. There! The word *charged* has suddenly come into the talk, because it



Fig. 3.— Taken from an actual photograph, this shows the electrons being emitted from a cathode and spraying on to the anode.

is so closely associated with the words positive and negative. "Charged" simply means containing electricity, and hence a positively charged substance is one which we assume to have an excess of electricity, according to the old idea. Now since the electron is a particle of electricity it seems illogical to say that it is *charged* with negative electricity, but that is the fault of the early theories that is persisting in our new ideas.

All we have to remember for the present is that an electron behaves as though it were negatively charged, and is therefore attracted to a substance which is positively charged. This is one of the fundamental laws of electricity—that oppositely charged bodies attract one another and similarly charged bodies repel one another.

It would take too much space to go further into this aspect of electrical theory, and besides, this is not a text-book on elementary electricity. But if you are interested enough to go into the matter from the beginning, get hold of a copy of Silvanus Thompson's "Elementary Lessons in Electricity and Magnetism." It is out of print now, but is one of the best little books on the subject ever written.

### Attracting the Electron

At any rate, we have found a means of attracting the electron, and of repelling it, too. And now we can go a stage further in considering what to do with the electron when it is produced from the atom by heating.

If we heat a wire in a vacuum, the electrons produced leave the surface atoms of the wire and tend to fly off into the surrounding air. That was explained last month. They do not go very far, even though there are no atoms of air to impede their movement, for two reasons: Their velocity is low, that is, the speed with which they are ejected is not sufficient to carry them any distance, and secondly, the first electrons to

leave the metal hang about the surface, and prevent the others from going beyond them.

Each electron, being negatively charged, will repel its neighbour, and if an initial layer of electrons is established above the surface of the metal, this will tend to push back other electrons which are on the point of leaving. Now, if we put a positively charged plate just above the surface of the metal, all the electrons which are produced will at once fly over to it due to its attraction (Fig. 2).

The higher the attractive force the faster they will travel. If the positive plate is connected through a battery to the heated metal, all the electrons attracted to the plate will find their way back to the heated metal via the battery, and we shall have a continual migration of electrons, or an electric current.

This is the simplest theory of the electron valve, which we use with such wonderful results wherever radio messages are being transmitted or received. Of course we do a great deal more to the electrons than just send them round and round in a ring, but that is how they are produced and made to flow in any path that we like to make for them.

### The Cathode-ray

The cathode-ray is an electron stream. Why, then, call it a cathode-ray? It is just another case of the survival of a term coined by early experimenters before the electron arrived on the scene. In the early vacuum tubes the electrons produced used to give the effect of an invisible ray proceeding from the cathode, and the name "cathode-ray" applied to this effect has stuck to the more modern tube.

The *cathode* is the name given to the source of electrons, or our bit of heated metal. The attracting plate which is mounted a little distance away from the cathode is called the *anode*, and those are all the technical terms we need for the present.

Look at the picture of Fig. 1. That is the business end of the cathode-ray tube (you can't

Fig. 4.— Showing what happens if a hole is made in the anode. The electrons travel at high speed and pass right through it to reach the end of the vacuum tube.

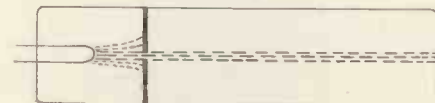

help calling it that—it's a habit), and all the elaborate pieces of metal are merely for the purpose of producing a stream of electrons, and having produced them, making them do what is wanted.

Fig. 3 is taken from an actual photograph of what goes on inside a cathode-ray tube. The cathode is the little hairpin-shaped wire, and opposite it is the anode, a flat plate. All the electrons produced by the cathode are being pulled over to the plate and the effect is rather as though the plate were being sprayed with water from the cathode, acting as a hosepipe. This



water idea is most useful, and will help to explain all sorts of things later. For the present it gives us a reason to use the words "jet" or "beam" when we are speaking of these electron movements.

### The Cathode

One or two little queries may occur to you as the sketch of Fig. 3 is considered. Why is the cathode a hair-pin? Why not have a fat bit of wire and get more electrons from the surface?

The answer is that the particular use which we have for these electrons requires them to be in the form of a narrow stream, and we are using a hair-pin of wire instead of a wider area in order to give a narrow area from which the electrons are produced initially. There is no point in producing a flood of electrons unless we intend to use them and collect all of them by the anode.

The pure metal is not a very good provider of electrons, and it is usually coated with a compound which gives them off in greater numbers when heated. This compound while giving a better yield initially has a tendency to fall off in its properties after a time and to become inactive. The cathode is then said to have become "de-activated" and its useful life is at an end, even though it is still capable of being heated.

### The Electron Jet

The speed with which the electrons fly to the anode is increased by increasing the attractive force of the anode, i.e., by applying a high potential. Potential and voltage are very much the same thing, and without going into more theory, we can take it that the attractive force of a positively charged plate is proportional to the electrical voltage applied to it. Applying a voltage is connecting a battery to the plate in such a way that the plate is positive, the negative end of the battery being connected to the cathode. The higher this voltage the greater the velocity which the arriving

electrons will acquire, and if it is of the order of 500 or 600 their speed is such that they hit the anode hard, if one can imagine such a tiny thing as an electron hitting anything hard!

The effect of this high speed is seen immediately if we bore a tiny hole in the centre of the anode. The electrons arriving at the centre will be travelling so fast that they will pass through the hole in the plate and go shooting on into the vacuum on the other side. If the anode was at the end of a very long tube they would go on until they hit the wall at the end. In fact, if their speed was high enough they wouldn't stop there, but would go clean through the glass. This sounds far-fetched, but there have been many cases in the early days of radio valves of the electron stream passing the anode and puncturing the glass bulb by their impact. The velocity of our electron stream is not as high as that, but we want them to hit the bulb at the end, since this is the principle on which we are basing the electron tube.

So now we have a jet of electrons produced by a hot cathode and passing through a tiny hole in an anode placed near it, proceeding up a long tube and finally coming to rest on the glass at the end. Next time we can tidy them up a bit and make their arrival on the glass visible to the eye.

### CATHODE-RAY SCREENS

According to *Electronics*, improvements in technique have enabled the Allen B. Du Mont Laboratories, of Upper Montclair, N.J., to overcome the blackening of the fluorescent screen when the electron beam is allowed to remain stationary. This means that the life of the screen is materially increased as the darkening caused deterioration of the fluorescent screen and hence loss of light. Furthermore, because of this defect in cathode-ray tubes previously it has not been practical to use them for certain uses, such as sound recording or indicating meters where the spot or line might remain stationary for a considerable period of time.

## Push-pull Modulation

**P**USH-PULL plate modulation seems to be the solution to the problem of modulating a high-power transmitter. Grid modulation is all very well but apparently quality is not up to the standard of plate modulation. Ordinary push-pull or even Class B modulation is bound to be more widely used in the future. Class B modulation is, in the States, the accepted arrangement for modulation of high-power rigs.

Here is a circuit for the connections between a push-pull modulator and the final P.A. It is simple and cannot be bettered. This circuit is applicable to all types of valves for Class B amplification.

The speech output from the modulator is fed into the P.A. circuit through an output transformer of the correct

ratio to match up the valves used. Simply consider the P.A. as a loud speaker when calculating the correct ratio

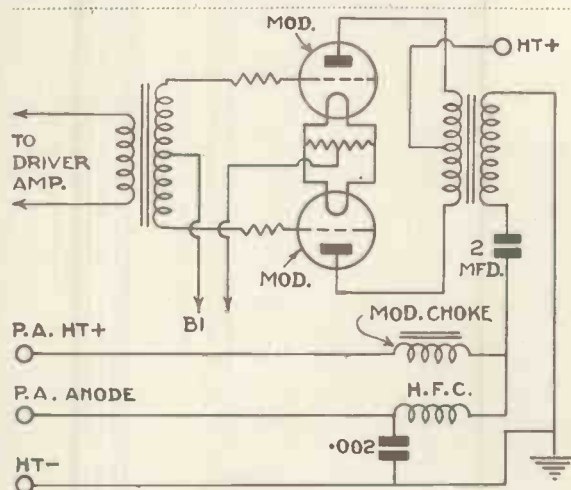

transformer for the job and use the standard formulæ.

H.T. for the P.A. is fed on to the anode through a low-frequency choke in series with a high-frequency choke. Do not forget the by-pass condenser of .002 mfd.; this is most important. A higher value will probably attenuate top notes.

Earth one side of the output transformer, but before doing so make sure the 2-mfd. blocking condenser is capable of standing up to the D.C. voltage applied to it, otherwise there will be trouble.

Try push-pull to increase the modulation percentage. There is not any need to alter the P.A. circuit with this arrangement.

# A NOVEL USE FOR THE SCANNING DISC

By S. Marks

*This article describes how a scanning disc can be used for checking camera shutter speeds, and it suggests a line of experiment for the amateur photographer.*

HERE is an example of a novel use to which a television receiver can be put.

A short time ago the writer made some alterations to the speed adjustments of the shutter on one of his cameras and therefore found it necessary to determine accurately the new shutter speeds. There are, of course, methods which make use of a white spot travelling at a constant speed across the field of the camera, but

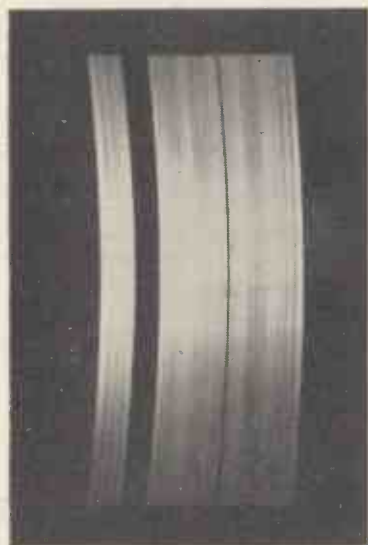

Fig. 1.—Illustrating the effect of an exposure of one-fifteenth sec. Note the vertical bands due to mains modulation on the lamp and indicating asynchronism. The thin vertical black line is a faulty hole in the disc.

these necessitate calculations involving the distance of the camera from the spot, the focal length of the lens and other factors which very easily introduce inaccuracies. It was in consequence of this that the author evolved the method described below, and which is, as far as he knows, original.

The camera, the shutter speeds of which it is desired to test, is set up on the tripod in front of a Nipkow disc televisor, as near to the latter as focusing arrangements will permit. In place of the normal flat-plate neon lamp a 100-watt gas-filled opal lamp is plugged into the lamp holder behind the disc and the 50 cycles supply mains connected to it. The motor

drive to the disc is then switched on to give it ample time to warm up to a steady speed of approximately 750 r.p.m. In the meantime the image of the scanning lines illuminated by the 100-watt lamp is focused dead sharp on the viewing screen of the camera. If the camera is of the roll-film variety with no focusing screen, it will be necessary to fit a temporary ground glass screen in such a position that the ground side of the screen is in exactly the plane normally occupied by the film (elastic bands or plasticine are very useful for this purpose). When focusing has been accomplished the temporary screen is removed and the camera loaded normally, great care being taken not to move the camera in the meantime. Focusing by scale should not be relied upon as at these short distances the adjustment is extremely critical.

When the speed is correct the screen of the televisor will be seen to have eight vertical stationary bands less brilliant than the remainder due to the light from the lamp fluctuating at twice the mains frequency. These bands can be clearly seen in Fig. 1. If the bands are moving from right to left the disc speed is too low and if they are moving from left to right the speed is too high.

## Calculating the Speed

Now all that remains is to expose a negative using the shutter speed it is required to test, bearing in mind that the effective exposure is extremely short owing to the speed of the scanning spot. It is, in fact, of the order of  $1/26,000$  sec. only, and it can easily be seen that this effective exposure is the same for all shutter speeds faster than  $2/25$  sec., the only difference being in the larger area exposed at the slower shutter speeds. Thus with an exposure of  $2/25$  sec. the whole of the scanning area will be exposed.

The illustrations to this article were taken on fast panchromatic film at an aperture of  $f4.5$ . Panchromatic negatives are essential owing to the necessity of high sensitivity to artificial light.

Having exposed a negative as above, develop fully, as the image will be somewhat thin, and fix as usual. There is no need to make a print; it is only necessary to examine the negative (with the aid of a magnifying glass if the image is very small) and count the number of scanning lines on it. In the case illustrated in Fig. 1 there are, by a lucky coincidence, exactly 26 lines on the negative. The nominal shutter speed used was  $1/15$  sec. The actual shutter speed is calculated thus:—

Since there are  $12\frac{1}{2}$  complete scans in one second,

30 lines are exposed in  $\frac{2}{25}$  sec.

26 lines are exposed in  $\frac{2}{25} \times \frac{26}{30}$  sec.

which is, almost exactly,  $1/15$  sec.

For the exposure illustrated in Fig. 2 the shutter was set to a speed of  $1/150$  sec. An examination of



Fig. 2.—Taken with a nominal shutter speed of  $1/150$  sec. Examination of the photo reveals that the actual exposure was  $1/144$  sec.

the photograph shows that approximately  $2\frac{3}{5}$  lines were exposed.

Thus the actual exposure was:—

$$\frac{2}{25} \times \frac{1}{30} \times \frac{13}{5} = \frac{1}{144} \text{ sec.}$$

As for a shutter speed of  $1/1,000$  sec. only  $3/8$  of one line would be exposed, it becomes necessary to know the area of negative which would be covered if the whole scan-

(Continued on page 262.)

# Heptodes on Short Waves

FROM every quarter different opinions as to the merits of heptodes for frequency-changers are heard. Occasionally amateurs do find that heptodes are suitable on wavelengths below 30 or 40 metres, but the

valve has a high degree of sensitivity and a great degree of reliability due to absence of the third grid (every additional electrode to a frequency-changer increases the difficulty in pumping and so obtaining a good vacuum).

switching has been arranged completely to cut out of circuit the coils not required. This is to prevent possible absorption at various frequencies.

As the secret to successful operation of a heptode lies in the coils, full constructional details of coils to cover the frequencies previously mentioned are given. Three points must not be forgotten. Maintain a high mutual inductance between the oscillator grid and anode coils. An oscillator voltage of about 10 volts peak is suggested. The .1-mfd. by-pass condenser for the screen

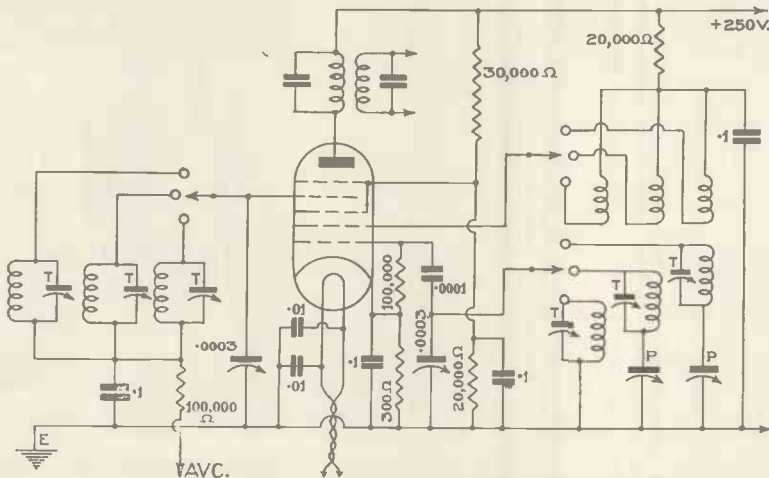

Fig. 1.—This is the heart of an efficient short-wave super-het. It can be added to almost any short-wave super but preferably one with 450 kc. I.F. transformers.

general impression is that some other means of frequency conversion must be used to obtain optimum efficiency.

It should not be inferred that the heptode is the most suitable valve for use in a short-wave receiver, but for a very big percentage of amateurs it has many advantages.

Again the heptode has a very low signal-to-noise ratio and introduces the minimum of harmonics. Finally, comes a most important point—no frequency pulling, that is, consistent frequency conversion over the whole wavelength scale.

A typical circuit for a heptode frequency-changer is shown in Fig. 1. Actually the circuit is for a triple-wave short-wave super-het covering wavebands between 1.5 and 4 megacycles, 4 and 10 megacycles, and 10 to 25 megacycles.

It is advisable to use an intermediate-frequency of 450 kilocycles in order to give complete stability on 25 megacycles, to overcome second channel interference as much as possible and to avoid drift of oscillator frequency.

So as to keep the positive potential on grids 3 and 5 absolutely constant it is essential that a low-resistance potentiometer be utilised to obtain this voltage. G<sub>2</sub>, the oscillator anode, may be fed via a series resistance as the voltage on this electrode is not particularly important. Too low a value of resistance will probably cause rough control and noticeable harmonics.

Modulation hum is noticeable below 14 megacycles, but this can be overcome by connecting two .01-mfd. condensers in series across the heater supply and joining the centre point to earth.

From Fig. 1 it will be seen that the

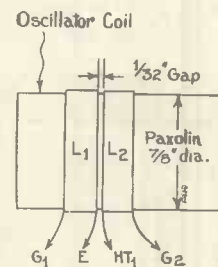

Fig. 4.—Here is the coil former, all the necessary winding data are given in the text in concise form.

must be kept close to the valve socket and have a low self-inductance, while any resistances in the A.V.C. feed to the grid circuit must be kept as low as possible. Half a megohm is the maximum permissible resistance.

Fig. 2 shows the switching, and a method of producing A.V.C. on two frequency-bands only. Experience has shown that the amount of control on the 25 megacycle band is negligible and it is advisable to have the receiver running at maximum sensitivity on this frequency.

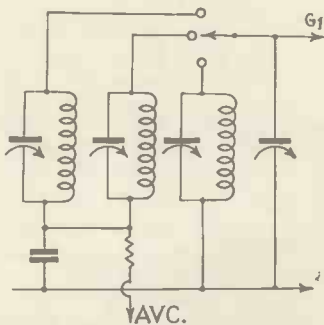

Fig. 2.—It is suggested that on the 25-megacycle band automatic-volume control be omitted. Notice that the third coil is then connected to earth.

First of all a heptode when correctly used will oscillate down to 15 metres, while we have used them down to 12 metres. A very good receiver can be built using home-constructed coils that will work excellently with a standard heptode such as the Osram MX40. This

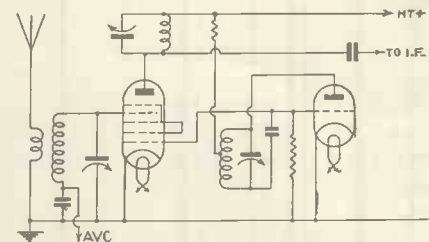

Fig. 3.—For ultra short-wave and/or television reception a separate oscillator is recommended in this circuit.

frequency. However, if it is desired to introduce A.V.C. on all bands, it only means one extra connection and this can be obtained from Fig. 1.

Below 25 megacycles the heptode is



definitely unsuitable for use as a combined detector-oscillator, but if it is used as a simple detector with a separate triode oscillator then results are highly satisfactory. This suggested arrangement, Fig. 3, actually is only a varia-

many problems connected with high-definition television reception. As regards the coil construction. The type of former recommended is shown in Fig. 4, and the method of construction is almost self-explanatory.

Frequency range	1.5 to 4.0 mc.	4 to 10 mc.	10 to 25 mc.
R.F. coil	37 turns	10 turns	4.5 turns
Osc. grid coil	33 "	9 "	4 "
Osc. plate coil	12 "	12 "	6 "
All coils wound with 32 S.W.G. wire.			
R.F. coil is single-layer wound on $\frac{7}{8}$ in. tube.			
Assuming an I.F. of 450 kc., the following constants will be correct:—			
Frequency range	1.5 to 4.0 mc.	4 to 10 mc.	10 to 25 mc.
Osc. grid coil	25 $\mu$ h.	3.6 $\mu$ h.	0.65 $\mu$ h.
R.F. coil	32.5 $\mu$ h.	4.5 $\mu$ h.	0.7 $\mu$ h.
Tracking condensers (P)	1,000 $\mu$ mf.	Not needed	
Trimming condensers (T)	Variable max. capacity 20 $\mu$ mf.		

tion on the triode heptode, but it certainly is extremely satisfactory down to 6 or 7 metres. Experiments tend to show it may prove to be the solution to

Here in tabulated form are concise details of the coil windings, type of wire, and the actual capacity required for padding.

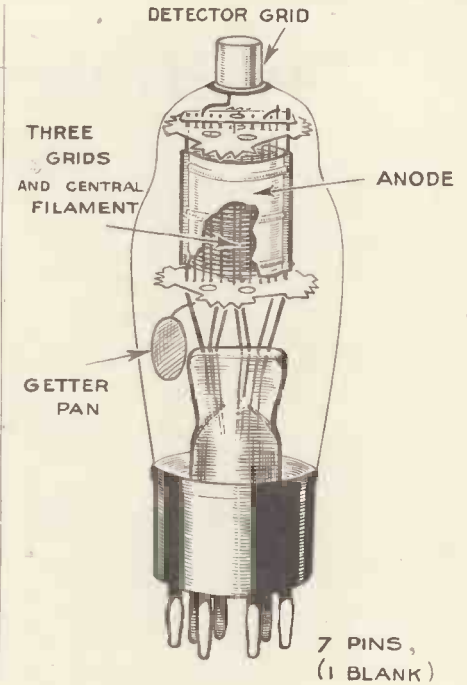

Fig. 5.—All the electrodes in this Osram heptode can be quite clearly seen. A point to remember is that the control grid is taken to the top cap.

**"A Novel Use for the Scanning Disc."**  
(Continued from page 260).

ning field were exposed. This can easily be obtained by measuring the size of the image on the ground glass focusing screen before taking the photograph. The simplest way is to set a pair of dividers to first the vertical, and then the horizontal dimensions, transferring them in turn to a piece of paper. It is useful to do this also at the lower shutter speeds as if the lines are rather indistinct it is only necessary to determine the ratio of exposed to unexposed area to calculate the shutter speed.

Obviously this method of shutter speed testing cannot be used for shutter speeds below 2/25 sec. unless some means is adopted for running the scanning disc at a slower known speed. For most purposes, however, this should suffice as shutter speeds generally range from 1/15 to 1/1,000 sec.

A mirror-drum receiver can be used just as easily for this purpose of checking shutter speeds. The procedure is almost identical, but the Kerr cell and Nicol prisms must be removed to allow sufficient light to pass through to the screen. Also, since the thick filament of the projection lamp is not modulated by the mains cyclic variations, a normal type of stroboscope must be used.

**Safety Regulations for Interference Suppressors.**

Interference suppressors of the simple condenser type are being used in many cases without due regard to the test voltage of the condensers used. The Council of the Radio Component Manufacturers' Federation have noted with alarm the steady increase in this practice.

Certain regulations have been drawn up in conjunction with representatives of I.E.E., R.M.A., B.B.C., G.P.O., B.E.A.M.A., and the British Electrical Industries Research Association.

It must be realised that it is totally inadequate to use a normal type of radio condenser tested at 500 or 750 volts D.C. in an interference suppressor which is to be used in conjunction with electrical apparatus tested at 1,500 volts A.C. from terminals to earth.

**3/6 per Quarter**  
**6/9 per Half-Year**  
**13/6 per Annum**

*will ensure "Television and Short-wave World" being delivered to you regularly each month.*

The condensers used must be capable of withstanding the same 1,500 volts A.C. tests or its equivalent 2,250 volts D.C. tests. In practice the specification fixed calls for the latter tests over a duration of one minute, since the A.C. test will be harmful to the life of the condenser.

In practice this means that the condensers must necessarily be three times the size and cost of the normal types of condensers used in a standard radio receiver.

Another standard that has been set is that an unearthened portable appliance must not have a larger condenser than .01 mfd. connected from either terminal to frame because of the risk of shock from an unearthened frame. This will probably mean special circuits, or chokes may have to be used as a substitute for larger condensers.

Quoting the R.C.M.F. report, we find that "Interference suppressors shall be protected by separate fusible cut-outs against the break-down or overload of any component, except when the suppressor is built into and forms an integral part of an appliance, or when the suppressor is so designed that it can only be used in sub-circuits which are already protected by fuses of a sufficiently low rating."

We should like to point out that the existing mains interference suppressors marketed by several firms are perfectly suitable for use in conjunction with standard radio receivers.

# RECENT TELEVISION DEVELOPMENTS

## A RECORD OF PATENTS AND PROGRESS *Specially Compiled for this Journal*

PATENTEES:—D. H. Byron and Radio Construction Co. Ltd.; A. C. Cossor, Ltd.; L. H. Bedford and O. S. Puckle; J. L. Baird and Baird Television, Ltd.; A. G. D. West and Baird Television, Ltd.; Radio Akt., D. S. Loewe and K. Schlesinger.

### “Test” Films for Television (Patent No. 423,050.)

A photographic record, which is intended to be used for simulating a television transmission, is made by projecting the picture from a photographic enlarger A on to a film F through a slit S which corresponds in position to one line of the television image. The slit is moved parallel to its own length, so as to correspond with successive scanning lines, by means of a micrometer screw M. In making a record for test purposes, the slit is set along the edge of the film F, corresponding to the first scanning line, and the film is fed forward by an amount not less than the length of the slit S. The slit is then moved by the screw M into position

for the second scanning line, and the film F again advanced the length of the slit, and so on.

The various movements may, of course, be effected automatically and at high speed. When finished, the film is attached to the periphery of a drum and used to control a “slit” source of light in a television receiver. It is pointed out that the scheme involves the use of photographic and mechanical processes only.—(D. H. Byron and Radio Reconstruction Co., Ltd.)

### Synchronising

(Patent No. 423,098.)

The “placing” of the line scanning movement and the fly-back of the spot at the end of each picture are both controlled directly from the transmitter by radiating a high-voltage impulse at line-frequency, and suppressing it once during each complete picture. The non-arrival of the suppressed scanning impulse is then utilised in the receiving circuits to discharge a condenser, which returns the spot to its initial position at the beginning of the first scanning line. A voltage-limiting device, such as a diode valve, is used to prevent false operation.

One advantage of the arrangement is that the picture fly-back takes place outside the area of the picture proper.

The synchronising signals as produced at the transmitter correspond to a voltage “blacker than black,” and produce in the receiver voltages stronger than any of those due to the picture signals.—(A. C. Cossor,

Ltd., L. H. Bedford and O. S. Puckle.)

### “Interleaved” Scanning (Patent No. 423,101.)

One alternative to the ordinary system of scanning is that known as

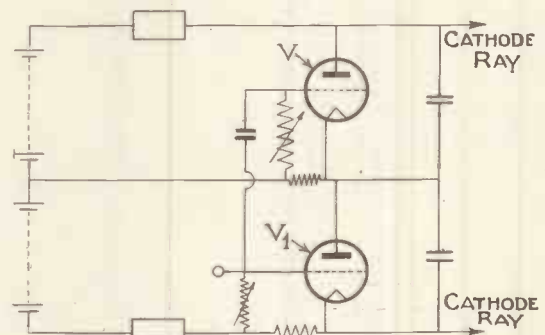

Fig. 1.—Circuit for producing interleaved scanning. Patent No. 423,101.

“interleaved” scanning. In this system two separate spots are made to alternate with each other in such a way that when one spot has finished the first line it is returned to a position where it repeats the first line scanned by the second spot, and so

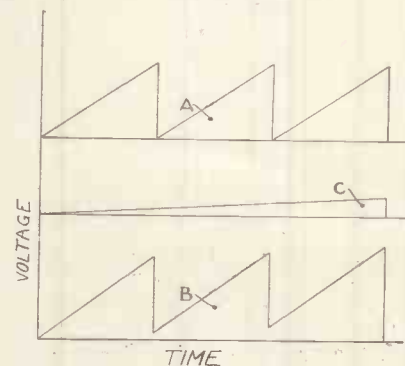
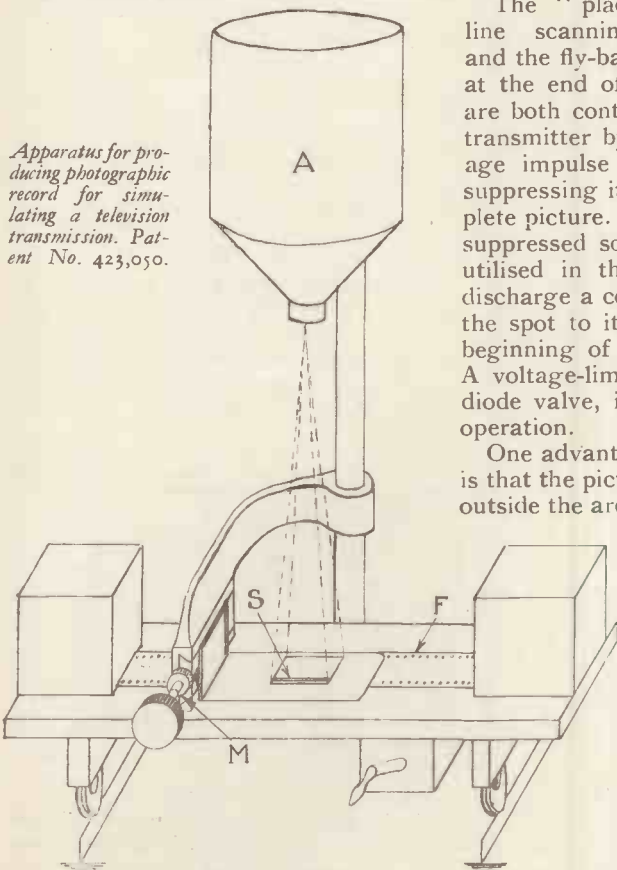

Fig. 2.—Wave-forms for interleaved scanning. Patent No. 423,101.

on. The idea is that owing to the persistence-of-vision effect, the definition given by two “interleaved” thirty-line scanners is approximately



Apparatus for producing photographic record for simulating a television transmission. Patent No. 423,050.

The information and illustrations on this page are given with the permission of the Controller of H.M. Stationery Office.

as good as that given by a single sixty-line scanner.

According to the invention the system is applied to a cathode-ray type of receiver, and the necessary interleaving of the scanning spots is secured by subjecting the cathode-ray to the combined effect of two independent valve-oscillators, one at least of which is of the saw-toothed type. As shown in Fig. 1 two saw-toothed oscillators V, V<sub>1</sub> are used, the cathode of V being connected to the anode of V<sub>1</sub>. The combined

The inventors overcome this difficulty by deliberately "spreading" the normal size of the spot as it reaches the screen, so that it affects an increased area of the sensitive material. The resulting distortion is offset by interposing a compensating lens between the screen and the observer. The spot is artificially "spread," in a direction at right angles to the scanning line, either by using a rectilinear cathode, or by superposing a small transverse vibration on the ordinary scanning movements of the cathode-ray beam.—(A. G. D. West and Baird Television, Ltd.)

**"Saw-toothed" Oscillators**

(Patent No. 423,394.)

One of the condensers C is charged up from a mains-supply unit M through a screen-grid valve V, which acts as a constant-current device. The condenser C is then discharged to produce line-scanning voltages for a cathode-ray television receiver through a gas-filled tube T, which may be of the Thyration type. The frequency of the scanning voltages is determined by selecting

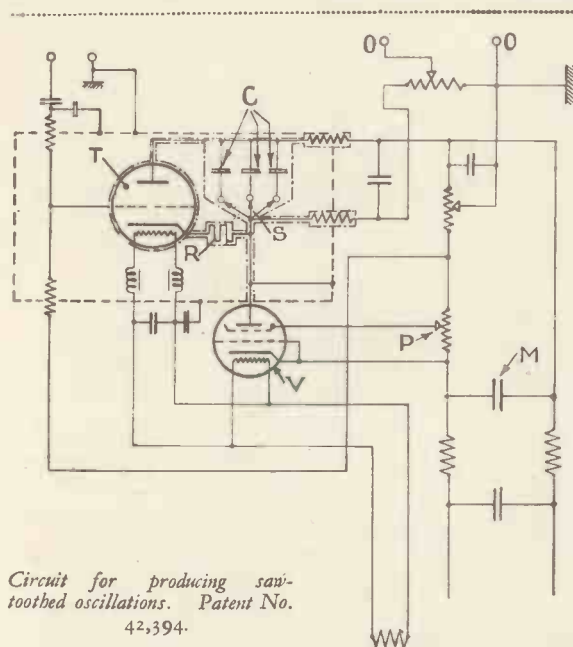

Circuit for producing saw-toothed oscillations. Patent No. 423,394.

oscillations generated across both valves in series are applied to the deflecting electrodes of the cathode-ray tube to produce the two scanning lines shown in Fig. 2. It will be seen that the lower ends of the curve B rise in steps, as compared with the curve A, by an amount represented by the wedge-shaped curve O.—(J. L. Baird and Baird Television, Ltd.)

**Viewing-Screens**  
(Patent No. 423,247.)

One of the difficulties in cathode-ray reception is to secure a strictly quantitative effect on the fluorescent screen. The fluorescence increases with the intensity of the cathode-ray only up to a certain point, after which the proportionality disappears. In this connection it has been found that the saturation point of the screen is not reached instantaneously, even for large values of excitation, though it is usually inadvisable to exceed certain limits owing to the danger of damaging or burning the fluorescent material.

a particular condenser C by means of a switch S, and by adjusting the biasing voltage on the screen grid of the valve V through a tapping P on the supply unit. The resulting saw-toothed oscillations are applied to the deflecting plates of the cathode-ray tube from the terminals O.

Owing to the effect of the gas in the tube T, the period of the discharge

slight "staggering" of the point of commencement of each line. To compensate for this, a resistance R is inserted in the cathode lead of the discharge tube, so that it is in series with the main discharge current and so serves to stabilise the frequency.—(Radio Akt. D. S. Loewe and K. Schlesinger.)

**Scanning Systems**

(Patent No. 423,427.)

Instead of anchoring one plate of each pair of the scanning electrodes in a cathode-ray receiver to a fixed voltage, the electrodes are worked in push-pull. The fact that the operating voltages are in phase opposition serves to minimise the distorting influence of one electrode upon a neighbouring electrode. For instance, the line-scanning voltages do not interact with the focusing or picture-signal voltages or with the framing voltages applied to the adjacent pair of scanning electrodes.

As shown in the figure, line-scanning voltages applied to the terminals O are amplified by the valve V and pass to the terminal K of the cathode-ray tube. A tapping T on the output circuit of the first valve is connected to the grid of the second amplifier V<sub>1</sub>, so that out-of-phase voltages are fed to the terminal K<sub>1</sub> supplying the opposite plate of that pair of electrodes in the cathode-ray tube. A second pair of amplifiers generates similar out-of-phase voltages for the frame-scanning electrodes of the tube. The terminal B supplies a biasing voltage to the scanning electrodes, which are kept approximately 500 volts negative to the anode.—(Radio Akt. D. S. Loewe and K. Schlesinger.)

**Summary of Other Television Patents**

(Patent No. 422,752.)

Mirror-screw scanning system utilising a Kerr cell light-relay.—(Suddeutsche "Tekade" Co.)

Circuit of push-pull system for cathode-ray tube.

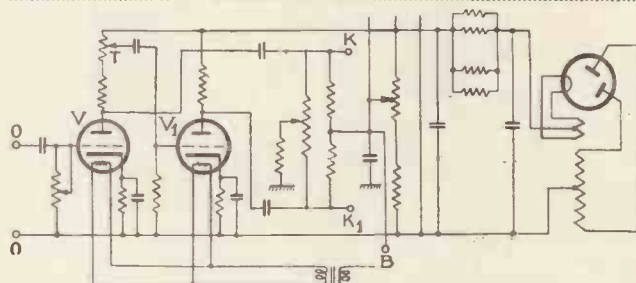

(Patent No. 422,914.)

Television system in which direct and low-frequency components are (Other patents on page 266.)



MAY, 1935

# DISTORTION IN CATHODE-RAY IMAGES

*Although the cathode-ray tube is recognised as the solution to most of the problems of high-frequency scanning, it should not be assumed that the tube is perfect in itself. There are a number of peculiar defects in the tube, either inherent to the construction or introduced by the scanning circuits, which will give rise to distorted pictures unless special steps are taken to minimise them.*

CATHODE-RAY tubes are of two types—gas-focused and high-vacuum. The former is going out of favour from the point of view of television on account of the larger number of errors introduced by its use, and the fact that its characteristics as a picture producer are inferior to those of the high-vacuum type.

With a line screen produced by suitable linear scanning circuits, the picture is projected on the screen by modulating the intensity of the beam with the incoming television signal.

## Defects in Gas-focused Tubes

For a given average intensity of spot on the screen the alteration of the shield potential by the signal should be such that the beam is cut

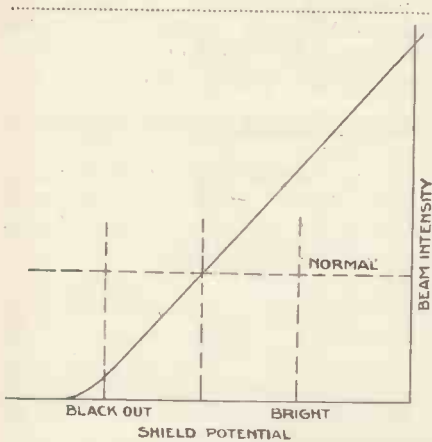

Fig. 1.—Ideal curve of beam intensity—shield potential giving full modulation with no distortion.

off altogether (producing the black portions) or increased in intensity by a corresponding amount to produce the bright portions. The action of the shield potential is in every way analogous to that of the grid of the valve, and to avoid distortion in the picture the incoming signal must vary this potential in a linear manner on either side of the working point, as

in Fig. 1. With the gas-focused tube this linear response is difficult to attain, and at the best it is only available over a limited portion of the intensity-shield potential characteristic. As the negative potential is increased the beam tends to lose focus, and the line screen itself becomes distorted, the lines becoming curled where the transition from black to white takes place (Fig. 2). The amplitude of the modulating signals is thus limited to such a degree that good black and white contrast is difficult to obtain.

## Origin Distortion

A second disadvantage of the gas-focused tube is in the "origin-distortion" produced by the non-linear response of the beam to small deflecting potentials. This, on a television line screen produces what is usually known as the "white cross," in which the centre of the screen is marked with a row of white dots and one of the vertical scanning lines appears more brilliant than the others. Various ways have been proposed to overcome this defect, from elaborate constructional alterations in the tube to the use of deflecting coils to push the cross off the screen.

Von Ardenne has patented a special arrangement of deflector plates to overcome the difficulty, but, while these remedies are of use in ordinary research work, the advantages of the high-vacuum tube are such that they are not now necessary in television.

Fig. 3.—Showing how the deflector plates P differ appreciably in potential from the second accelerator. This causes de-focusing of the beam on parts of the screen.

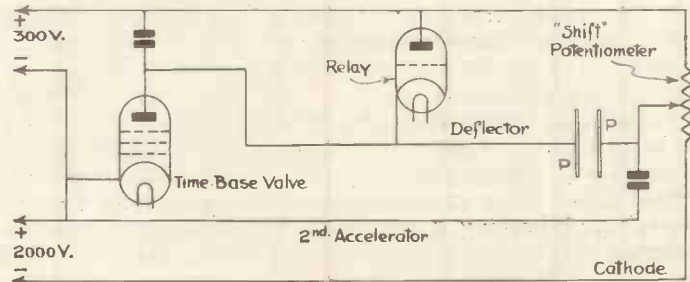

## High-vacuum Tubes

The high-vacuum tube suffers from neither of the above defects since the beam intensity is to a large extent independent of the focus. For a given combination of focusing potentials on the accelerators the intensity can be fully modulated without loss of sharpness, even with a large number of lines. Further, since there is no gas, origin distortion is absent, and the screen is of uniform bright-



Fig. 2.—Distortion due to over-modulation producing curvature of the scanning line besides a soot and whitewash effect.

ness. There are, however, other defects which arise in the use of the high-vacuum tube which require special means to overcome them.

To appreciate the first defect it is

necessary to remember that the focusing of the beam depends on the potential of the final field through which it passes on its way to the screen. With the deflector plates connected to the second accelerator, this potential is that of the second accelerator itself, and the spot can be focused in the usual way. When, however, a deflecting voltage is applied to the plates these will fluctuate in potential above and below that of the second accelerator, and thus tend to alter the focus of the beam.

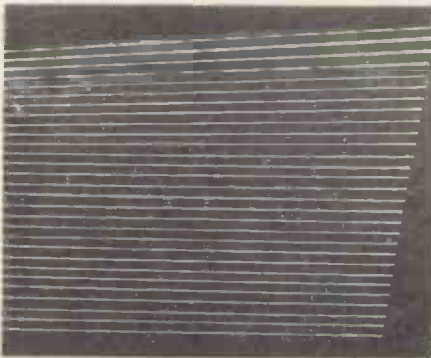

Fig. 4.—A line screen in the form of a trapezium caused by interaction of the deflector plates with high scanning potentials.

The effect of the deflector plate potential will depend on its value, but, since the high-vacuum tube is inherently less sensitive than the gas-focused type, it is possible that the deflecting potential may be as much as 20 per cent of the accelerator

potential. The diagram of Fig. 3 shows a simple time-base circuit connected to one deflecting plate, the negative of the time-base H.T. being connected to the accelerator. Reversing the connections of the scanning circuit does not alter the conditions, but makes the deflector negative to the accelerator, instead of positive.

In either case a loss of focus on large scans is the result. A second effect which is caused by the fluctuations in the deflector plate potential is that which gives rise to a trapezium-shaped line screen instead of a rectangular one. This is shown exaggeratedly in Fig. 4 and is due to the effect of one pair of deflector plates on the other; in other words, a form of cross-modulation! The fact that the two pairs of deflector plates are mounted at different distances from the accelerator also produces a certain amount of distortion due to the variation caused in the velocity of the beam as it passes through them in turn.

The majority of the distortion due to the interaction between deflectors and their action on the accelerator can be minimised by ensuring that the deflecting potential varies by an equal amount on each side of a mean value, and that no plate is thus at a permanently higher or lower potential than the accelerator.

To ensure this a symmetrical arrangement of the deflecting circuit must be devised on the principle

shown in Fig. 5. In this the fluctuating component of the time-base potential is applied to the plate through a condenser, thus avoiding a permanent D.C. bias, and the deflector plates themselves are connected together by a high resistance, the centre point of which is connected to the accelerator.

A balanced circuit for the linear deflection has been developed by the

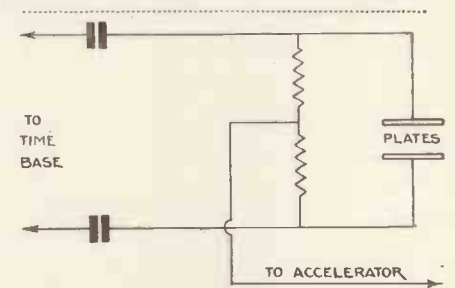

Fig. 5.—Symmetrical circuit for balancing potentials applied to the deflector plates to overcome distortion.

Cossor Co., in which the potential of the charging condenser has a portion applied to the grid of a valve. This portion is adjusted so that the potential in the anode circuit is equal and opposite in phase to that developed across the remainder of the charging circuit. The deflector plates are connected through the isolating condensers shown in Fig. 5. A similar "push-pull" arrangement can be adapted to the resistance-capacity time-base recently described in this journal (December, 1934).

"Additional Patent Summaries"

(Continued from page 264.)

(Patent No. 420,679.)

Filtering system for separating-out signal and synchronising signals in television.—(Radio Akt. D. S. Loewe and K. Schlesinger.)

(Patent No. 420,727.)

System for maintaining correct "tone" values in television.—(Fernseh Akt.)

(Patent No. 420,881.)

Improvements in the electrode system of cathode-ray tubes operating as intensity modulators.—(Radio Akt. D. S. Loewe.)

(Patent No. 422,824.)

Television system in which compensation is made for slow changes in the average picture illumination.—(Electric and Musical Industries, Ltd., P. W. Willans, W. S. Percival, E. L. C. White and H. E. F. Osborne.)

(Patent No. 422,906.)

Means for preserving the absolute level of brightness in a series of televised pictures.—(Electrical and Musical Industries, Ltd., and P. W. Willans.)

Standard Terms and Definitions

Photo-electric Cells

Since the Research Committee of the Television Society published their list of recommendations (see page 317, July, 1934, issue), further meetings have taken place between the Technical Committee of the British Standards Institution and the Research Committee, and agreement has now been reached on the definitions printed below, which replace those previously printed:—

*Photo-electric Cell.* (Abbreviation—*Photo-cell*). A device such that one or more of the electrical properties undergoes a change when it is exposed to light.

*Photo-emissive Photo-electric Cell.* (Abbreviation—*Photo-emissive Cell*). A photo-electric cell in which the light causes the emission of electrons from a metallic surface in an evacuated or gas-filled envelope.

*Photo-electrolytic Photo-electric Cell.* (Abbreviation—*Photo-electrolytic Cell*). A photo-electrolytic cell in which the light sets up a difference of potential between two similar electrodes immersed in electrolyte.

*Rectifier Photo-electric Cell.* (Abbreviation—*Rectifier Photo Cell*). A photo-electric cell in which the light causes the passage of electrons across a rectifying contact gap between the bounding surfaces of a conductor and a semi-conductor.





# STUDIO & SCREEN

## REVIEWS OF THE PROGRAMMES AND RECEPTION REPORTS

**B**Y the sudden change in television hours at Easter lookers have lost their Saturday matinee programmes. Schoolboys are disappointed that this alteration had to be made in the holidays, but it was inevitable. The claims of sport is the reason given by the B.B.C.

On April 27 the wavelengths were needed for the Cup Final commentary, on May 11 they will be wanted for the Rugby League final, and throughout the summer there will be a succession of sports relays on Saturday afternoons. Also on Saturdays special programmes will be broadcast for the entertainment of Jubilee crowds waiting for Their Majesties' drives. Let us face facts. Until television commands a bigger public, commentaries on Test matches and tennis championships have prior claims.

While the trade loses an opportunity for day-time demonstration

the change brings certain gains. Last minute cuts will no longer be necessary to accommodate preceding programmes running late. It is impossible to time a sporting relay exactly and recently several Saturday transmissions have had to be shortened on this account.

\* \* \*

Artists are temperamental creatures and delays and uncertainty at the start are risky in the novel and peculiar conditions of the television studio. For lookers waiting at home it was a strain to concentrate on a screen while nothing happened. So a cause of anxiety to the producer and an aggravation to the looker should be removed by the change, though I notice with some apprehension that the Grand Opera season will soon be with us.

Relays from Covent Garden caused several late starts last season and a programme beginning after 11.30

p.m. finishes very late indeed. The public for a programme after midnight must be negligible, and it would be better to switch a transmission from one night to another than to start at this hour. A few days' notice should be possible and announcements from the television studio during programmes would be effectual.

\* \* \*

A small crystal microphone at the end of a wand has replaced the bomb-like condenser microphone which has been used for so long. While the relatively heavy condenser instrument could be pushed about the studio on its stand, the advantage of infinite movement is claimed for the new instrument.

A little larger than a match box it is plugged into the end of a thin brass rod about two feet long, the other end of the rod being connected by flex to an amplifier in the control room. Its range is thus limited only by the length of the flex attached to the rod and it can be placed at a moment's notice in any position in the studio from floor to ceiling and when carried in the hand can follow an artist's movements about the studio.

In a close-up, while an artist is stationary, the microphone rests on a support beside the projection window, and when the artist retreats for a distant shot the rod is carried by an attendant "off stage" to the back of the studio. The instrument has not yet been seen on the screen; it is a pity that it was not ready at Christmas when it might have been waved by a fairy. D. R. Campbell was responsible for this arrangement of the microphone, which has already produced a more even transmission of sound.

\* \* \*

The problem of sound is somewhat similar in television and film studios, though different technique is required for instantaneous transmission when it is impossible to go back on a shot,



*A technician explaining the function of a Cossor cathode-ray tube to some members of the Cambridge Boat Race crew. (Left to right)—W. C. R. M. Lourie, J. H. C. Powell, D. C. Kingsford and J. N. Duckworth (holding tube.)*



or to add an effect afterwards. In film studios the difficulty of concealing the microphone has been overcome by the use of elaborate gear and engineers are now experimenting with a wooden boom hung across a corner of the television studio. If this were used lateral and vertical movement could be secured by suspending the microphone from a cord passing through a number of pulleys, but I doubt whether such an arrangement would produce better results than the wand.

\* \* \*

Although no hint of its intentions is yet available at the B.B.C, the probable nature of early high-definition programmes is an interesting speculation. I have never believed that television will damage cinematograph interests and discussing the prospects with an enlightened member of the film trade I discovered that we shared certain beliefs.

We agreed that for many years the full-length picture will not be wanted

in the home. Screens will be small at first and the effort of concentration for an hour and a half will be much too great. Domestic interruption is also a factor to be considered. Short, snappy and varied programmes should be broadcast so that lookers may tune at any time during transmission with a guarantee that their entertainment will not be spoiled through having missed half a film. News reels and shorts would be almost ideal, and it is not for such items that millions pour into the cinemas each week; the "big" picture is always the attraction.

Believing that this difference is fundamental, I see no conflict of interests. The cinema could release such reels for television without prejudice to their business.

The supply of short pictures showing for only ten or fifteen minutes is limited and would fairly soon become exhausted in a regular programme service. It seems probable, therefore, that there will be a demand for

short films which can be produced quickly and cheaply, specially for the new medium. Through the hire of existing films and the production of new pictures, television may in time provide a source of income for the film business.

\* \* \*

Some bright programmes have been seen and heard during the month. Joan Carr, a radio discovery with an alluring voice, showed that Hollywood experience is an asset in the studio, and several sketches which had been broadcast in the monthly revues gained fresh point from being seen.

---

## Anti-television Publicity

**A** PROPOS of the suggestions that some of the big radio manufacturers are using their influence with the Press to stifle television, Mr. Howard Flynn, managing director of Edison Bell (1933), Ltd., in the course of an interview which he accorded a representative of *Advertisers' Weekly*, said:—

"I notice that television is described as a scare. This is perfectly ridiculous. Television is not a scare. Television is here now.

"The present situation savours of racketeering methods. The trouble is that in this country there are 15,000,000 radio sets—which is far too many. The trade has reached a saturated point just as it is doing in America. The situation is merely a repeat of what happened to the piano and the gramophone industries.

"Personally I fail to see how radio manufacturers or anyone else can prevent the publication of news about television. If there is news there, the Press will publish it.

"The opposition says that programmes are not frequent enough or long enough to justify the ownership of a television set. This again is a rather curious situation. I know for a fact that a complete service of high-definition television programmes is possible to-morrow.

"Scare or no scare, I am going ahead with my own plans for marketing television sets.

"I intend to spend about £10,000 on advertising. I am not using threats, but if newspapers choose to bar television, they will suffer in twelve months' time."



Miss Pearl Rivers who appeared during April in songs and dances.

# SOME PROBLEMS OF HIGH-DEFINITION MECHANICAL SCANNING

By Robert Desmond

*The production of high-definition pictures by mechanical scanning methods provides some problems which are receiving the attention of those who are interested in mechanical systems. This article gives an outline of some of the difficulties which will have to be surmounted. It refers, of course, to systems which are ordinarily used and not those of a specialised nature which are being developed in this country.*

ONE of the results of the Television Committee's Report has been to cause considerable controversy among television enthusiasts as to the respective merits of cathode-ray and mechanical receivers. Many people are of the opinion that the mechanical scanners must entirely give way to those of the electronic type.

Mass has always been somewhat of a bugbear with all mechanical scanners, and it is this "masslessness" relatively, of the cathode-ray scanner which so weighs the scales in its favour. Sometimes we are rather in-

as the muzzle velocity of a rifle bullet.

It is obvious from the above that though the mechanical mass which controls the light beam has not such a high speed in lineal footage, the speed is, however, very high and the mass of the moving parts must be kept low unless considerable power is available to control it. By way of comparison the spot of the present service travels about 126.6 miles per hour on a 6-inch-high screen. The foregoing gives us an insight what the process of scanning requires.

Now let us see how a mechanical

The mirror-drum provides even worse problems, apart from the fact that it is always much heavier. On such a drum the cant between adjacent mirrors would be only .004683 of a degree, with a radial spacing of 1.5 degrees. While the latter is a relatively easy mechanical proposition, one wonders who would like to tackle the former, from the constructional point of view.

## Synchronising Difficulties

So much for the problems of construction. In considering these difficulties we must not overlook the problem of constant rotation. "Hunting" of one degree, plus or minus, on a thirty lines, represents a rise or fall of the picture by one-twelfth of its height; on 240 lines two-thirds of its breadth, just tolerable on 30 lines, would be quite impossible on 240 lines.

It is obviously quite clear that if mechanical scanners are going to be used on high-definition, they must be rather different to what we have been accustomed. The two movements of scanning, spot and line traverse, could be produced by two moving systems. For example, the two mirror-drums A and B, in Fig. 1, which have their mirrors parallel to the axes, can be made to give the necessary results. If a beam of light is projected on to a mirror-drum and the drum rotated, the reflected beam will sweep along a given direction, this direction being changed by a mirror such as one on the drum B, which is at right angles to drum A. Now if A was stationary and B rotated, the light beam would sweep in a direction which would be at right angles to the previous conditions. By rotating both, the combined effect will cause the light beam to scan an area whose length and breadth can be arranged according to the relative

(Continued on page 270)

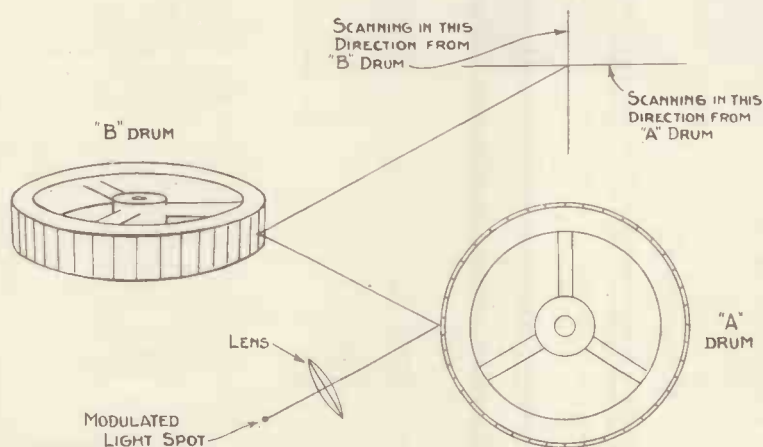

*A suggested scheme for high-definition mechanical scanning employing two mirror-drums.*

clined to forget what the scanning spot has to do in the way of travelling.

## Scanning-spot Speed

Suppose we have a screen 6 ins. wide scanned by 240 lines 25 times per second. The spot travels 125 ft. per picture, 3,125 ft. per second, which, given in the nomenclature of the man in the street, is 2,130 miles per hour or about half as fast again

system can produce the necessary effect. To produce a picture of 1 in. by .75 in. on a disc with the usual flat plate light source one would require a disc of 240 holes spaced angularly by 1.5 degrees, the pitch being such as number one is spaced radially from number two hundred and forty by .75 in. Such a disc would not be less than 6.3 ft. in diameter. Size alone rules out such a disc, even if one could reasonably construct it, quite apart from the power required to rotate it 25 times per second.



# THE B.E.R.U. SHORT WAVE CONTESTS

First details of the present position of the 1935 contests.

By E. N. Adcock, G 2D V.

WHEN the Radio Society of Great Britain sponsored the first British Empire Contest in 1930, it was little thought that this test would become one of the greatest annual events in the world of amateur radio. Judging by the stations heard competing, this year's entry will create a record.

For over a week before the commencement of the first round on February 2, conditions were very poor on the 20- and 40-metre amateur bands, and we here in England wondered if any DX would be heard during the contest. Zero hour at 17.00 G.M.T., however, saw the

going great guns. Situated centrally as he is with easy contact to all parts of the Empire it was soon apparent that, barring accidents, he must win this year's contest, the "one point per contact" ruling being particularly in the favour of a station so situated. Stations in VQ3-4 (Kenya and Tanganyika) were also putting very consistent signals into this country, but wasted much time sending "Test BERU," while English stations were waiting in a queue to work them.

From 24.00 to 05.00 G.M.T. the next morning little was to be heard apart from a few South American stations,

At 9 a.m. most English stations moved down to the 20-metre band, and at the writer's station excellent signals from ZL and VK were immediately audible, lasting until 4 p.m., a most unusual state of affairs. VK5SU, of South Australia, was particularly prominent, being a loud speaker signal most of the time. It might be mentioned here that a little study of the directional effect of receiving aerials for this band would be well repaid in contact work. At G2DV comparisons on VK5SU's signals on three directional tuned aerials gave R2-R3 in two cases and R8 with the remaining antenna.

This particular one was a full-wave zepp (tuned for reception) running due north to south. Around 1-2 p.m. signals from VP4 (British Honduras) and VP5 (Jamaica) came over well but, as in the 1932 test, conditions to Canada were very poor, only two contacts being obtained on this band with this usually easily contacted zone.

4 p.m. saw most of the G's back on 7 mc. Signals from Hong Kong and Australia came over well, despite the bad interference from continental telephony stations. When will this useless telephone work be banned on 7 mc.?

Conditions were similar in the first week-end of the Junior tests, but in general fell off slightly during the remainder of the contest, although conditions for Canada improved. No signals were heard from Iraq, but unusual contacts with VQ8A (Ascension Island), VS8AB (Bahrein Island), and V8 (Mauritius) were made by English stations.

In conclusion, it must be said that those competing had a most enjoyable time, and look forward with pleasure to next year's event. Competitors' logs should provide valuable data on propagation.



The photograph shows, from left to right, the Senior Trophy, the Junior Low-power Cup and the prize to be won by the listening competitor. The small cup replica of the Senior Trophy will be retained by the winner.

7 mc. band spring to life. DX stations appeared miraculously. (This effect incidentally is frequently noticeable at contest times, and leads to the belief that apparent "bad conditions" may often be ascribed to stations being inactive.)

Australian and South African stations were to be heard at R5-7 up to 24.00, and were easily contacted. From 20.00-23.00 several Indian stations were at good strength, VU2JT being particularly prominent. That seasoned competitor, SUIEC, of Cairo, was heard

which several G stations contacted "just to keep their hands in." At 5 a.m. ZC (Palestine) and SU (Egypt) were active, while at 6 a.m. the New Zealanders started coming over, with the stalwart ZL3FG leading the van with a consistent R8 signal. Australian signals also appeared again around 7.30, and both ZL and VK were excellent strength until around 10 a.m. Contact was attended with considerable difficulty, however, as terrific interference from U.S.A. stations was being experienced in the Antipodes.

general fell off slightly during the remainder of the contest, although conditions for Canada improved. No signals were heard from Iraq, but unusual contacts with VQ8A (Ascension Island), VS8AB (Bahrein Island), and V8 (Mauritius) were made by English stations.

In conclusion, it must be said that those competing had a most enjoyable time, and look forward with pleasure to next year's event. Competitors' logs should provide valuable data on propagation.

## "Some Problems of High-definition Mechanical Scanning"

(Continued from page 269.)

positions of the two drums and the screen.

For a 240-line picture, 25 times per second, the A drum could have 60 mirrors rotating 100 times per second, or 120 mirrors rotating 50 times per second with the B drum, in both cases with 25 mirrors rotating once per second. The object of reducing the mirrors on A is to

simplify construction and allow more light to be reflected for a given size drum, which unfortunately is rather offset by the necessary high speed of rotation. A Nipkow disc with a similar number of holes equispaced from the centre could be substituted for the A drum, though it would probably cause too much loss of light.

With regard to the constancy of rotation, this would require the same accuracy as a 240 drum or disc. It might also be possible to substitute

oscillating mirrors for both drums, especially the B one, but this is a problem for some ingenious designer.

Another problem with mechanical systems is the modulated light source. It is doubtful if we know of a method of modulating light over such a wide frequency-band. There seem great hopes from a system of electronic bombardment of certain materials, producing an intense light source, rather like that which takes place in a cathode-ray tube.



# A TELEVISION TEST TRANSMITTER FOR 7 METRES

By J. H. Reyner, B.Sc., A.M.I.E.E.

*There is much interesting work to be done on the 7-metre band but development is being handicapped by the absence of definite transmissions, either of speech or television. The remedy is to generate one's own high-frequency energy and the transmitter described herewith has been designed for this purpose.*

THE power required for a test transmitter for most purposes is comparatively small and in the present instance the circuit has been designed to fall within the customary Post Office 10-watt limitation, this being the anode dissipation of the oscillator valve. Under these conditions an oscillating power of 1 to 1½ watts can be obtained actually in the aerial, the total closed-circuit power being about 3 watts, which constitutes an efficiency of 30 per cent.

While we are accustomed with broadcast transmitters to talk of efficiencies of the order of 70-80 per cent., it is well known that these figures fall off rapidly as the wavelength is reduced, and an efficiency of the order quoted on wavelengths between 5 and 10 metres is recognised as good going. Added to which an aerial power of 1 to 1½ watts is sufficient for all normal requirements.

There are occasions where more power than this is required and for this purpose the present transmitter has been designed so that it may be used as a drive oscillator for a power amplifying valve. One or two valves have been put on the market just recently specially intended for the ultra-short waves and some details of a power amplifier for 7 metres will be given at a later stage for the benefit of those readers who are

interested. The present article is concerned with the low-power portion only.

The production of satisfactory oscillation in the 5-10-metre range is not easy. The inductance must be small and it is therefore difficult to obtain a satisfactory LC ratio. My earliest experiments were made with small coils of heavy-gauge copper wire wound about 1½ ins. diameter. Both grid and anode were tapped along the coil as indicated in Fig. 1 so that the optimum anode

impedance could be found by adjusting the anode tap, and the grid tap could be adjusted to give the most efficient oscillating conditions. Unfortunately the results were disappointing. The oscillating current obtained was not by any means up to standard and there was, moreover, a strong tendency to oscillate at frequencies quite independent of those to which the circuit was tuned.

After some experimenting it was found that this was due to the leads between the valve and the tuned circuit. Although these had been kept as short as possible by practically hanging the tuned circuit on to the valve holder, yet the circuit constituted by the leads and the tuning condenser shown in dotted line in Fig. 1 appeared to be an easier circuit in which to maintain

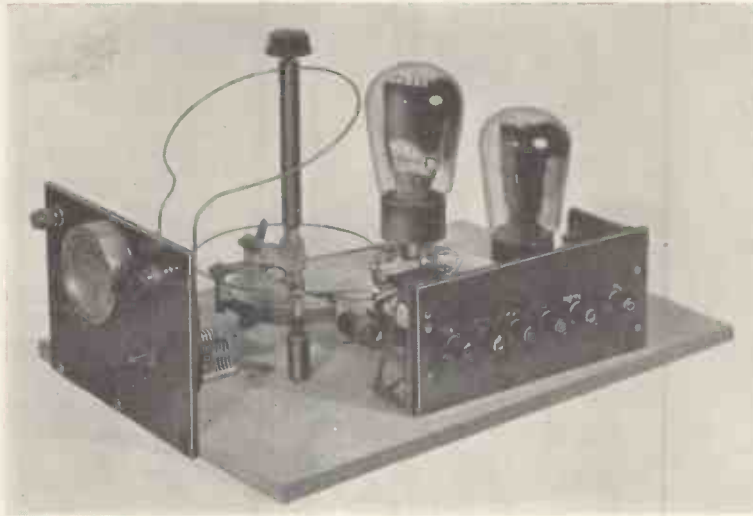

The 7-metre test transmitter.

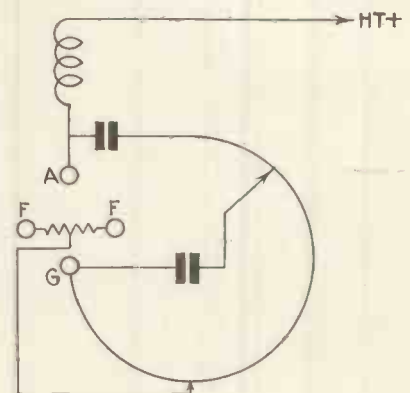
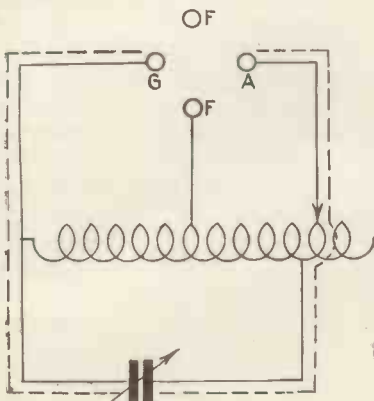

Fig. 1 (left).—The leads to the valve form an oscillating circuit as shown.

Fig. 2 (right).—The layout of circuit finally adopted.

Fig. 3 (above).—Simple half-wave aerial.

## PRODUCING TEST TRANSMISSIONS

oscillation than the carefully-constructed coil which had been intended to carry the current.

The simplest solution of the problem was to allow the circuit to oscillate this way and consequently the tuned circuit took the form of a single loop of wire from anode to grid. Across part of this loop the tuning condenser was connected, while the filament was tapped at a suitable intermediate point as shown in Fig. 2.

I found that this arrangement would oscillate quite easily and strongly even with a fairly large condenser. This latter point is an advantage because one of the dangers with short-wave transmitters is that the valve

two 'ebonite pillars tapped 4 B.A. at each end. There are three supports around the fixed plates and I removed the terminals from the two opposite ones and screwed on the two ebonite feet. Then the whole condenser was mounted on the baseboard by screwing up from underneath.

This mounted the condenser horizontally, with the spindle vertical and a long extension handle was used on the spindle to avoid hand-capacity when tuning. The coil itself consists of a simple lead of 14 s.w.g. bare copper wire running from anode to grid round the outside of the condenser as shown, on a diameter of ap-

Fig. 4 (below).—Half-wave aerial with feeders.

Fig. 5 (right).—Theoretical circuit of transmitter.

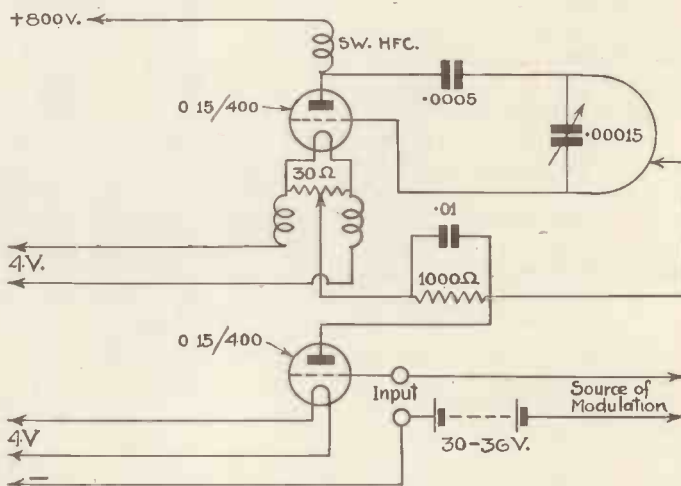
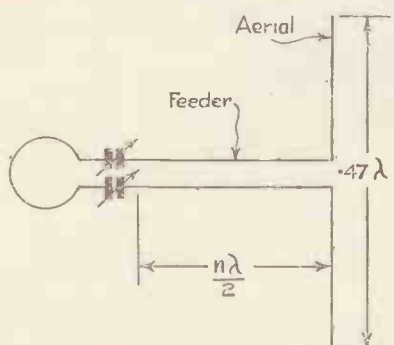

capacity may constitute quite an appreciable portion of the total capacity of the circuit. In these circumstances if the oscillating current is heavy, the glass in the pinch of the valve begins to heat up and the valve may deteriorate. In the present instance the circuit oscillates over a range of 5-11 metres and, since it will normally be wanted for wavelengths around 7-10 metres, where there is quite an appreciable capacity in parallel with the coil, this difficulty does not arise.

A further advantage of the arrangement is that, since the coil inductance is relatively small, the resistance loss in the wire is also small. This is an advantage, of course, because we do not want to waste the power in the closed circuit losses but wish to draw off as much as possible externally, as will be seen later.

The next point is that of the valve. A valve with a normal output of three to four watts will be required and after some experimenting I decided on a Tungstram O 15/400 which, as the name implies, is an oscillator rated at 15 watts anode dissipation and 400 volts H.T. This valve, though not specially designed for ultra-short-wave work, is an excellent oscillator and went down quite satisfactorily to below 5 metres. Actually with the final circuit the minimum was 5.25 metres, which I considered satisfactory for the purpose.

It was not necessary to "de-cap" the valve, but I did mount it, as a precaution, on a Frequentite valve holder and used a special Eddystone short-wave condenser for the tuning. This condenser was mounted on

proximately  $4\frac{1}{2}$  ins. The moving plates of the condenser were connected direct to grid while the fixed plates were connected to a point on the coil about 2 ins. away from the anode condenser. The correct choice of this point has some influence on the efficiency of the circuit since it alters the anode tap, but, since the filament tap is made variable, it will be sufficient to make a fixed connection from the fixed plates of the condenser to the coil as shown and to make the adjustment on the filament tap.

The valve is self-biased by means of a 1,000-ohm resistance with a .01 mica condenser across it. One end of this bias resistance is connected to a hum-dinger across the filament terminals of the valve holder while the other end is taken through a short flexible lead terminating in a crocodile clip to a point about 4 ins. from the grid of the oscillating circuit. As already explained, the position of this connection is critical. The circuit will oscillate over quite wide variation but the maximum oscillating current is obtained when the clip is at the one particular point. The exact spot is best determined by trial, the output being estimated as described later on.

Short-wave chokes are included in the filament leads, these being composed of lengths of glazite or similar stiff insulated wire coiled into a spiral as shown in the figures. About 10 turns half an inch in diameter will suffice.

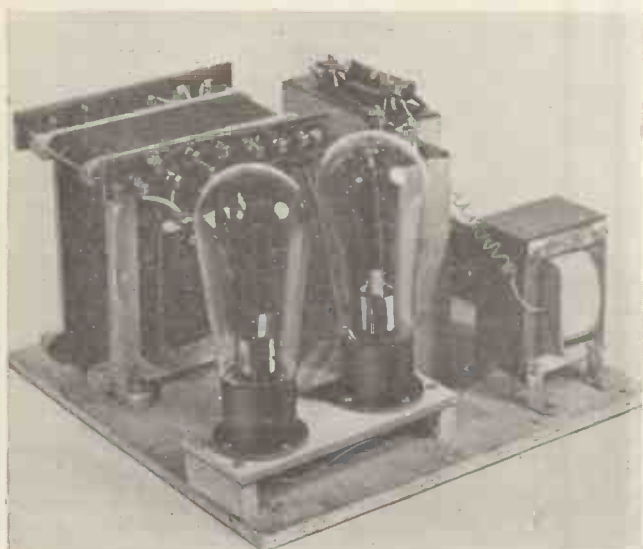

Photograph of the power unit for 7-metre transmitter.

### Output Arrangements

In order usefully to extract the energy from the oscillating circuit a simple coupled coil was used. This took the form of a loop of wire, again about 4½ ins. in diameter, the ends of which were connected to two .0001 μF. variable condensers mounted on a small panel. The same panel also contained a 0.5 amp. hot-wire meter for indicating the current in the output circuit.

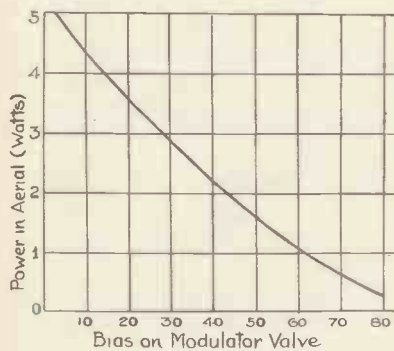

Fig. 6 (left).—Modulation characteristic.

Fig. 7 (right).—Circuit of power unit.

The load circuit may consist of simply a non-inductive resistance of a value suitable for the particular experiment or an actual aerial. Two aerial arrangements are indicated in Figs. 3 and 4.

The first of these is a simple horizontal di-pole just under half a wavelength long. The length need not be exact because variations of plus or minus 20 per cent. can be compensated for by suitable adjustment of the tuning condensers. The table herewith gives correct lengths:—

Wavelength (metres).	Approximate length of aerial (feet).
6	9½
7	11
8	12½
9	14
10	15½

The two condensers should both be adjusted until maximum current is obtained on the ammeter. As far as possible the adjustment should be made so that the two condensers are of equal capacity and actually the maximum current will be obtained when this is done. A horizontal di-pole like this will give good radiation over quite a distance and the signals may be picked up off another horizontal aerial of a similar type.

A vertical aerial may be used if desired of exactly the same type, or alternatively the power may be supplied to a vertical aerial through a feeder system. In the latter case the length of the feeder must be adjusted to be approximately a multiple of half a wavelength long, but the process of tuning is the same, both the condensers being adjusted until the maximum current is obtained on the meter.

The distance between the coupling coil and the main oscillating coil must be six inches at least and I found it convenient to use 14-gauge wire and merely to bend the coupling loop nearer to or farther away from the oscillating circuit until the best results were obtained. If the loop is too far away it will not be possible to transfer the maximum power from the oscillating circuit into the aerial. If it is too near the operation is not stable and it will be found that as the tuning condensers are varied in the aerial circuit the current gradually increases and then suddenly drops back. This is because the frequency of the oscillation has suddenly changed due to pulling between aerial and primary cir-

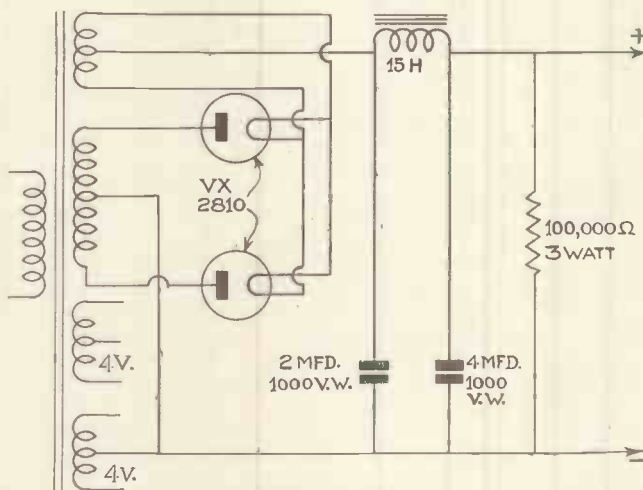

cuit and the coupling must be weakened until this pulling is no longer in evidence.

### Modulation

We now come to the question of the modulation of the current and here a somewhat special circuit has been used. The ordinary choke modulating system has several disadvantages for a transmitter of this type, the main ones being:—

1. The frequency response is limited both in the low and the high frequencies. Since experimental television transmitters require a very wide frequency range this is a serious limitation.
2. The modulator valve has to be several times larger than the oscillator valve, or alternatively a bank of valves in parallel must be employed. Otherwise it

(Continued on page 295)



## Television with Batteries.

*Excellent Results in Cumberland.*

**G**OOD results with television in Workington, Cumberland, about three hundred miles from the transmitting station, are not expected with the best of sets, but Mr. Harold

used, but discarded in favour of a Mervyn scanning disc. An electric horn motor drove it, governed by gramophone governors, and supported on some bed iron. Meccano parts were used exten-

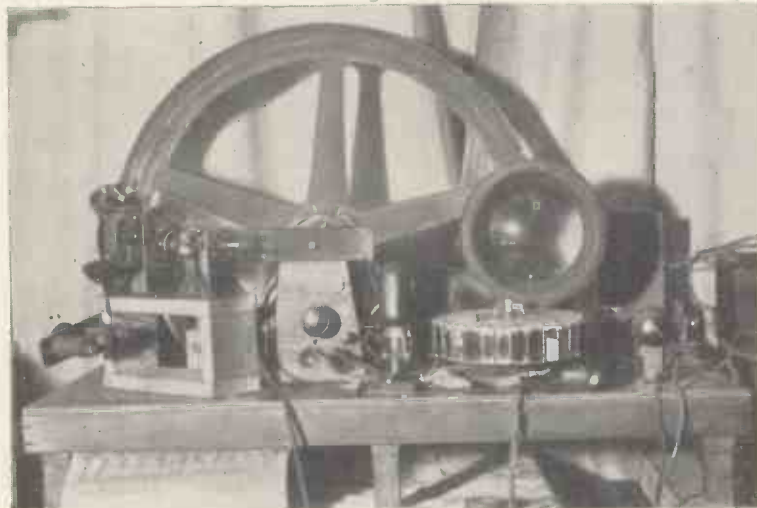

*The amateur apparatus constructed by Mr. H. Dunn, of Workington.*

Dunn, of Roper Street, Workington, motor mechanic, has constructed a television receiver from all sorts of "bits and pieces," and receives splendid pictures on Wednesday nights.

In 1927 he heard a lecture by Mr. Dinsdale, on television, and was immediately taken up with the new branch of wireless. He commenced to build his first receiver which was used, with good results all last winter. He used a Kolster Brandes battery set, model KB242 for the vision and a small three-valve Philips mains set for sound. For the K.B. set he used a Philips' eliminator, 150 volts, 30 mA output, and a set of double-capacity Exide H.T. batteries at 120 volts. In the original television receiver, cardboard discs were

sively. A headlamp, and an old-fashioned bull's-eye lens, in conjunction with a Woolworth lens, formed the optical arrangement and the lamp was an ordinary beehive neon.

Recently Mr. Dunn has constructed a motor to run off the mains, and has discarded the old horn motor (seen in the left in the photograph). His results have immensely improved and he hopes to still further enhance the vision when he has completed a mirror-drum (to the right of the photograph shown above).

Attempts have been made to procure photographs of the reception on Mr. Dunn's receiver, but they have failed, even though panchromatic plates were used.

### Edison Bell Television

#### Receivers

We understand that the Edison Bell Co. are ready to go into production with two types of cathode-ray receivers immediately high-definition transmissions are available. The two receivers ready for production are fundamentally similar except that one is of the console type and the other a table model. The console model in addition incorporates a short-wave sound receiver.

Fifty guineas has been fixed as the price of the console model, which will include two short-wave receivers, one

for vision and one for sound, and the complete cathode-ray equipment.

The table model is priced at 30 guineas and includes a short-wave receiver for vision and the complete cathode-ray equipment. It is intended that sound be received by a separate short-wave converter. The aperture for the tube and the picture area is a rectangle 12 ins. by 9 ins.

### LENSES and MIRRORS

LARGE STOCKS KEPT

Anything made to individual requirements by the ACTUAL MANUFACTURERS.

M. & S. HUMMEL, 94 Hatton Garden, E.C.1  
Holborn 1752.

### Self-generating Photo-cell

**A**LAYER of copper oxide on a copper disc has some unusual and interesting properties. Many readers are familiar with the copper-oxide rectifier which has been widely used for several years. The new Photox photo-cell may be called the cousin of this. It, too, is a copper disc with a coating of oxide, but instead of rectifying, it acts as a tiny primary battery when light strikes its surface. The current generated is measured in micro-amperes but is sufficient to be extremely useful.

The current output is directly proportional to the intensity of the light which strikes it and retains this property indefinitely. Its response to coloured light is another interesting characteristic. The response is almost exactly the same as that of the human eye. Thus a coloured light which seems bright to the eye seems bright to the Photox. This property has become the basis of the light-intensity meter and the transparency meter.—*Electronics.*

### German High-definition Transmission

We learn from the Reichs-Rundfunk-Gesellschaft that the transmission times of the Berlin television station are as follows:—

*Sound Transmitter.*—Wavelength 7.2 metres, power 16 kilowatts.

*Television Transmitter.*—Wavelength 7.006 metres, power 16 kilowatts.

*Times of transmissions.*—Daily 9 a.m., 11 a.m., 8.30 p.m., 10 p.m., except Fridays and Sundays.

It will be noticed that there is some modification of the particulars published in last month's issue.

### An Experimental Oscillator Tone Source

Owing to the demands upon our space in this issue we have been obliged to hold over the particulars of the method of calibrating the oscillator tone source described last month. It should be noted that some typographical errors appeared on page 209, column 3, in the figures as under.

1st line	120,000	should be	1,020,000
8th	80,000	„ „	800,000
10th	20,000	„ „	200,000
13th	20,000	„ „	200,000
14th	80,000	„ „	800,000

# Scannings and Reflections

By THE LOOKER



## Photo- Electricity

THE sensitive element in a photo-electric cell usually consists of one or more of the alkali metals such as potassium, rubidium, or caesium, which react to the ray of light by emitting free electrons to form a discharge current. This so-called photo-electric action is, however, shared in greater or less degree by quite a large number of other elements, including arsenic, sulphur, carbon, and many of the oxides and sulphides of the heavy metals.

The effect can be measured by suspending finely-divided particles of the substance between the plates of a condenser, the voltage being adjusted until the tendency of the particles to fall under gravity is just counterbalanced by the electrostatic attraction of the charge on the plate. If the cloud of particles is then illuminated by a ray of light, the resulting emission of electrons upsets the state of equilibrium and causes a slow drift of the cloud of particles towards the negative plate of the condenser. By carefully observing the rate of movement it is possible to calculate the number of electrons emitted, and therefore the photo-electric response of the substance under test.

## Financing the Programmes

The cost of providing studio programmes is going to be a big item once television gets properly under way, so that it may be necessary to find new ways for making the service self-supporting—without having to raise the 10s. licence fee. I have never liked the American idea of running the broadcast services solely on the revenue produced by advertising, but I do think there is something to be said in favour of the so-called "double-chain" system, which is now being operated in France and elsewhere.

There, although most of the stations are kept under Government con-

trol, two or three wavelengths are specially allotted to independent stations, which are run as commercial concerns and live on the revenue earned by advertising. The point is, of course, that nobody need tune into these stations unless they want to, or unless the programme is sufficiently attractive to make up for occasional spots of "publicity."

Television is as much open to be used for advertising purposes as broadcasting, and there may be room for some development on these lines, particularly at a time when money is scarce and expenses high. For one thing there is plenty of ether-room for any number of television centres, with very little risk of interference on account of the restricted range of 7-metre waves; and for another, the offer of, say, a three-years' lease might start things going in some of the big provincial towns, where interest in television is just as keen as it is in London—though the prospect of getting an "official" high-definition service is still a long way off.

## Looking Forward

A correspondent, who is of an inventive turn of mind, puts forward a somewhat startling proposition. Apparently his idea is that having satisfied the ears with broadcasting, and the eyes with television, it is time to try and do something for the olfactory sense. He points out, for instance, that a very tiny spot of musk will scent a large room for years, which obviously means that it is a vigorous radiator of particles of matter capable of affecting the nose. If every corner in a large room can be reached in this way by a purely natural process, what, he asks, might not be done if we could only intensify the process, and direct it like we do a 7-metre wireless wave.

Honestly, I don't know—though I quite agree that there are localities where a broadcast service, say, of eau-de-cologne, would be a definite boon to humanity. On the other

hand, chlorine gas has a similar uncanny power of radiating itself over considerable distances, and if anybody discovers how to broadcast it on a large scale the famous "death ray" we read so much about in popular fiction may turn out to be a stern reality.

I ought perhaps to add that this suggestion reached me long before the first of April, which was the auspicious date actually chosen by a German station to announce the carrying-out of just such an experiment. Listeners were solemnly informed that wax records of various scents had been prepared by a special process and would be radiated on the usual carrier-wave. Odorous effects were to be expected *via* the loud-speaker, and reports as to the quality and/or intensity of reception were invited. Here at all events is one way of broadcasting what might be called a scent(s) of humour.

## The "Stillies"

I was rather amused to hear that America is preparing to launch out on a large scale with a broadcast service of still-life pictures, just at the time when Europe, as a whole, is going strong on real television. As a matter of fact there is very little connection between the two movements. Still-pictures enjoyed a certain vogue over here some years ago, with the Fultograph, but interest soon lapsed and has not, so far, been revived.

The American stunt is chiefly based on the prospects of sending out "hot-news bulletins" during the early-morning hours—when ordinary broadcasting has finished and the transmitting station would otherwise be closed down. The receiver, which is left on all night, automatically reproduces the messages as they come in on a small picture-copying attachment, so that the family is able to regale itself at breakfast with later information than that contained in the usual morning paper.



**The B.B.C. and Short-wave Reception**

I learn that the B.B.C. are having some trouble just now with their Five-Hours-Back Relay. It is not to be wondered, therefore, that amateurs have stopped making contacts with American stations on 20 metres. For no reason at all reception conditions on this band have suddenly deteriorated, and instead of being better than they have been for years are now almost useless.

**The First Transmitter**

At the time of writing no decision has been made by the Advisory Committee regarding the site of the first high-definition transmitter despite the many statements that have appeared in the Press. Alexandra Palace seems to be the favourite. One good reason for setting the London television station up at Alexandra Palace in North London is that this building is situated on a hill over 300 ft. above sea level. There are towers of nearly 145 ft. at each of the four corners, thus giving an effective aerial height of about 450 ft. That is the sort of height that is needed to give an adequate service to the London district on ultra-short waves.

From one of the towers, by the

way, it is said to be possible at night to see a red light on the Southend Pier.

It is to be hoped that the Advisory Committee will be able to decide very shortly where the first high-definition station is to be erected. Even when that point has been decided there will still be a great deal of planning to be done before the B.B.C. can put the building of the plant in hand.

I understand that a special extension to Broadcasting House will include a complete set of properly-equipped television studios, housed inside a special "tower," as was done in the main building.

**Television in Germany**

A friend who has just returned from Berlin tells me he was not particularly impressed with the television he saw there. Although 180-line cathode-ray receivers were in use, the definition was not as good as the equivalent Baird transmissions. It is, however, the intention of the German engineers to increase the definition as soon as possible for they claim that television will not have any real entertainment value under 360 lines. This is rather interesting for it shows that the Television Com-

mittee were not far wrong when they asked for 240-line service.

Those who feel that this is too ambitious will now perhaps realise that other countries have even more ambitious programmes in view. Incidentally, France is determined not to be left behind. Ultra-short wave television transmissions are to be inaugurated.

On ground of public economy the policy will be pursued in Germany of erecting a relatively small number of television transmitting stations with largest possible range. Since the range is determined by the height of the aerial, it has been decided to establish aeriels at the top of very tall masts on flat land and on the highest hills in mountainous districts.

The researches conducted recently by the German Postal Administration in conjunction with the cable industry have resulted in the manufacture of a special type of cable suitable for television. A cable of this kind will shortly be laid in Berlin. The next step will be to experiment with long-distance relaying of television by means of cables. If that proves successful, it should then be possible, as with the present sound apparatus, to relay visually the scenes at any place desired, first to the transmitter and then over the ether to the radio audience.

**Percentage of Modulation**

By ARTHUR WESTON

IT is most important to be able directly to read the actual percentages of modulation of a carrier if quality is to be kept up to a high level. To adjust low-frequency gain to give maximum permissible modulation is all very well with only one station operator, but it is very likely that a second operator would cause either over or under modulation according to the strength of voice.

A number of amateur stations find difficulty in keeping the modulation level constant, particularly on music. I have often heard a station putting out good quality speech followed by bad music due to the over modulation of the carrier. The output from the pick-up is very much higher than from the most sensitive microphone, so that distortion is not to be wondered at.

In my own case, where the modulator is rather on the large side for the 10-watt carrier, particular care has to be taken to prevent variation in modulation and distortion creeping in.

A simple unit by which the modula-

tion can be measured was made up and so far has proved very useful indeed. Coil L<sub>1</sub> and condenser C make available a voltage of any magnitude to be fed into the grid of the triode valve. Without any current in L<sub>1</sub>, and with

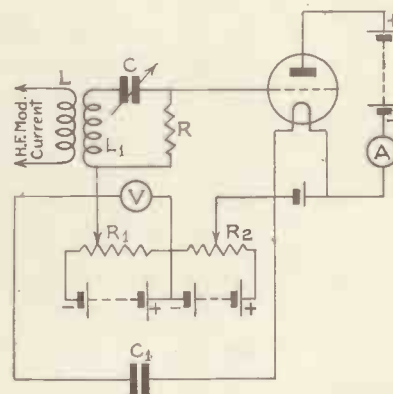

This is the circuit for the suggested meter. It is better to use this than to rely on the fact that 23 per cent. rise should mean 100 per cent. modulation.

R<sub>1</sub> set at zero, resistance R<sub>2</sub> is adjusted to make the plate current return to zero. This current is read on the milliamperemeter A. An unmodulated carrier is then applied to L when the milliamperemeter will read a certain current.

With R<sub>2</sub> left fixed R<sub>1</sub> is adjusted to make the meter again return to zero. The reading on the voltmeter is also taken. Call that reading V<sub>1</sub>.

The carrier is then modulated when the milliamperemeter will read because of the increased amplitude of the positive A.C. on the grid of the triode. R<sub>1</sub> is then increased until the milliamperemeter again reads zero. The reading on the voltmeter is also taken and that, ready for reference, is called V<sub>2</sub>.

Percentage modulation is obtained from the formula:  $M = 100 (V_2 - V_1) / V_1$ .

It is possible to calibrate the meter in percentage modulation when it is to be used with one particular station. To do this adjust R<sub>1</sub> to make the milliamperemeter to read zero, after which it is left set. This adjustment is made without modulation. The milliamperemeter will then give readings as the modulation is increased. The scale can then be adjusted to read in percentage modulation.



This article outlines the possibility of the construction of an entirely new type of Kerr cell in which one electrode is a metal

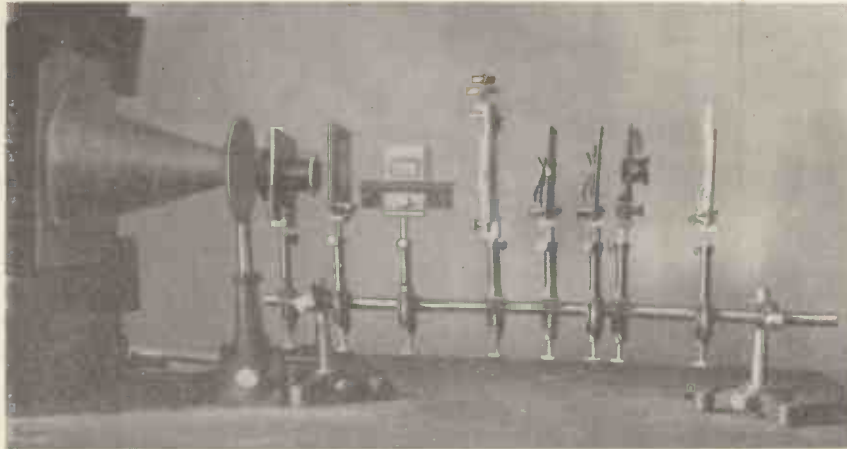

A photograph of the circular polariscope in use.

cylinder and the other a central co-axial wire. The article was contributed in Oct.

1934.

# THE CIRCULAR POLARISCOPE IN TELEVISION

By L. M. Myers

THE present form of polariscope employed in conjunction with the Kerr cell for the purpose of modulating a light beam is the plane polariscope. The Nicols are crossed, and the retardation set up in the nitro-benzene brings about an illumination of the field. The retardation is similar to that produced in a negative uniaxial crystal section such, for instance, as calcite. The retardation in calcite is given by the simple expression

$$R = \left( \frac{1}{V_1} - \frac{1}{V_2} \right) d$$

and the retardation in an electrostatically stressed material is given by

$$R = \left( \frac{1}{V_1} - \frac{1}{V_2} \right) d$$

In both cases  $d$  represents the thickness of the material parallel to the direction of the light and  $V_1$  and  $V_2$  are the velocities of the light vibrating in the two mutually perpendicular vibration directions:

For calcite the light vibrating in the principal plane, the plane containing both the optic axis and the direction of travel of the light, has the greater velocity. For stressed nitro-benzene the light vibrating in the direction of the electrostatic stress also travels the faster. The value of

$$\left( \frac{1}{V_1} - \frac{1}{V_2} \right)$$

is, of course, con-

stant for the uniaxial crystal, but for the nitro-benzene it depends on the

stress to which it is subjected so that we can put

$$\left( \frac{1}{V_1} - \frac{1}{V_2} \right) = CH^2$$

or  $R = CH^2d$

in which  $H$  is the measure of the electrostatic field and  $C$  is a constant.  $C$  varies for different materials and may be called the electrostatic stress-optical coefficient in harmony with the stress-optical coefficient suggested by Filon in connection with retardation brought about by mechanical stress.

brought about by the angular phase difference.

The retardation already considered as in terms of the wavelength, but it will be more convenient to deal the angular retardation between the two beams of light passing through the material. If  $\delta$  is the angular retardation, or the phase difference, then its relation to the linear retardation  $R$  will be expressed by

$$\frac{\delta}{2\pi} = \frac{R}{\lambda}$$

## Light Intensity

We are now in a position to determine the intensity of light leaving the polariscope assuming the Nicols to be crossed, which is the case for all adaptations of the Kerr cell. Let the angle between the principal plane of the analysing Nicol and the direction of the electrostatic stress be  $\theta$ , then if light vibrating in the principal plane of the polariser be of the form

$$a \sin \omega t$$

when it has reached the stressed material we have to resolve it in the vibration directions of the material.

In Fig. 1  $PP'$  is the vibration direction of the polariser and  $OX$  and  $OY$  are the vibration directions of the stressed material. Let  $OX$  be the fast direction, that is the direction parallel to that of the stress.  $AA'$  is the vibration direction of the analyser

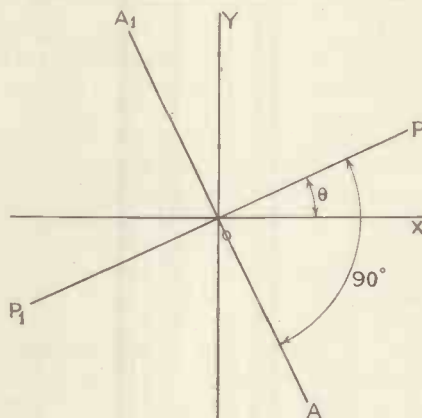

Fig. 1.—Linear polariscope with crossed nicols.— $PP'$  is the vibration direction of polariser;  $AA'$  is the vibration direction of analyser;  $OX, OY$  are the vibration directions of birefringent section in the polariscope.

It is usual when considering the intensity of light passing through the polariscope to calculate the effect

THE TELEVISION ENGINEER

which is crossed with, or at right-angles to, the polariser. Resolving the light vibration from the polariser in the vibration directions of the material we have

$$x = a \sin \omega t \cos \Theta$$

and

$$y = a \sin \omega t \sin \Theta.$$

When the light emerges from the material there will be a phase difference of  $\delta$  to be introduced in the fast direction so that the emerging light is of the form

$$\bar{x} = a \sin (\omega t + \delta) \cos \Theta.$$

$$\bar{y} = a \sin \omega t \sin \Theta.$$

We have now to resolve this light in

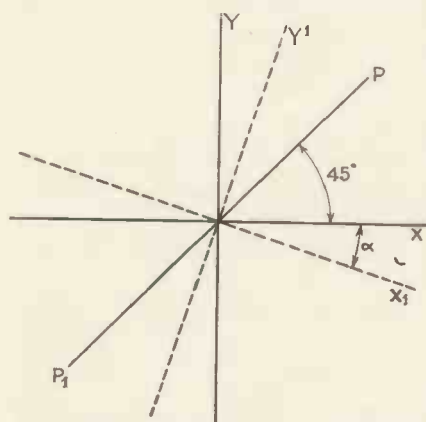

Fig. 2.—The circular polariser and analyser.—PP<sub>1</sub> is the nicol with quarter-wave plate OX; OX<sub>1</sub> is the analysing quarter-wave plate.

the vibration direction of the analyser so that the light emerging from the analyser will be of the form

$$A = y \cos \Theta - x \sin \Theta$$

$$= a [\sin \omega t \sin \Theta \cos \Theta - \sin (\omega t + \delta) \sin \Theta \cos \Theta]$$

$$= \frac{a}{2} \sin 2 \Theta [\sin \omega t - \sin (\omega t + \delta)]$$

$$= \frac{a}{2} \sin 2 \Theta [\sin \omega t - \sin \omega t \cos \delta - \cos \omega t \sin \delta]$$

Collecting the coefficients of  $\sin \omega t$  and  $\cos \omega t$  we have

$$A = \frac{a}{2} \sin 2 \Theta [\sin \omega t (1 - \cos \delta) - \cos \omega t \sin \delta]$$

so that the intensity of the light, which is proportional to the square of the amplitudes is

$$I = \frac{a^2}{4} \sin^2 2 \Theta [(1 + \cos^2 \delta)$$

$$- 2 \cos \delta) + \sin^2 \delta]$$

$$= a^2 \sin^2 2 \Theta \left( \frac{1 - \cos \delta}{2} \right)$$

$$= a^2 \sin^2 2 \Theta \sin^2 \delta/2.$$

For maximum intensity for a given retardation we must have  $\Theta = 45^\circ$ , which is a well-known practical fact.

The Circular Polariscope

In this form of polariscope no results can be obtained which are of any practical value unless the Nicols are crossed. In what follows, however, we shall discuss a different form of polariscope, which will be effective for any orientation of the Nicols and also, which is important, for any possible azimuth of the vibration directions of the stressed material.

Such a polariscope which will work for any position of the Nicols is the circular polariscope. Apparently the first suggestion of the circular polariscope came from Airy in 1833. (*Trans. Cam. Phil. Soc.*, Vol. iv, 1833). He was the first to suggest an analyser for circularly polarised light.

The polariser consists simply of a Nicol to which is permanently fixed a quarter-wave plate with its vibration directions inclined at  $45^\circ$  to the vibration direction of the Nicol. Then it follows that the light leaving this combination will be circularly polarised, whether right-handed or left-handed will depend on the azimuth of the fast direction of the quarter-wave plate in relation with the direction of the polarising Nicol.

The analyser consists also of a Nicol to which is permanently fixed a second quarter wave plate. The combination is therefore a circular analyser. The fast direction of the plate is so fixed with respect to that of the Nicol such that the light leaving the polariser and being, say, right-handed becomes, on travelling through the analysing quarter-wave plate, linearly polarised with its vibration direction perpendicular to that of the analysing Nicol so that it will be extinguished.

Having set up the polariscope in this manner we shall show that extinction will take place for all possible relative orientations of polariser and analyser.

Let the light emerging from polarising Nicol be of the form

$$a \sin \omega t$$

then upon entering the quarter-wave plate we resolve in the two vibration

directions which are inclined at  $45^\circ$  to that of the Nicol. We have, therefore, Fig. 2.

$x = a \sin \omega t \cos 45^\circ$   
and  $y = a \sin \omega t \sin 45^\circ$   
PP' being the vibration direction of the Nicol and OX and OY the vibration directions of the plate, OX is the fast direction. When the light emerges from the quarter-wave plate

a phase difference of  $\frac{\pi}{2}$  has been introduced in the fast direction so that we have

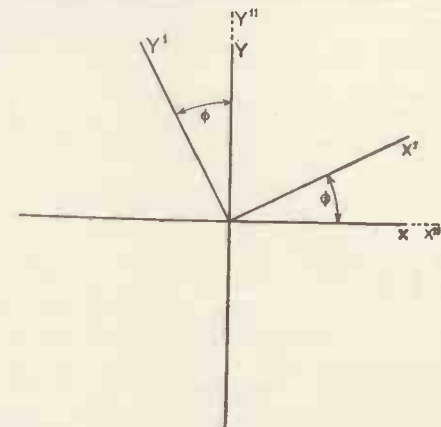

Fig. 3.—OX=fast direction of first quarter-wave plate; OX' =fast direction of birefringent section; OX''=fast direction of analysing quarter-wave plate.

$$x = \frac{a}{\sqrt{2}} \sin (\omega t + \pi/2)$$

$$y = \frac{a}{\sqrt{2}} \sin \omega t$$

The light now enters the analysing quarter-wave plate whose vibration directions are inclined  $\alpha$  to those of the polarising plate. Resolving the light in the two new vibration directions we have for the light entering the plate

$$x_1 = \frac{a}{\sqrt{2}} \left\{ \begin{array}{l} \sin (\omega t + \pi/2) \cos \alpha \\ + \sin \omega t \sin \alpha \end{array} \right.$$

$$y_1 = \frac{a}{\sqrt{2}} \left\{ \begin{array}{l} \sin \omega t \sin \alpha \\ - \sin (\omega t + \pi/2) \cos \alpha \end{array} \right.$$

and for the light emerging from the plate, a further phase difference of  $\pi/2$  having been introduced in the fast, OX' direction, we have,

$$x_1 = \frac{a}{\sqrt{2}} \left\{ \begin{array}{l} \sin (\omega t + \pi) \cos \alpha \\ - \sin (\omega t + \pi/2) \sin \alpha \end{array} \right.$$

THE TELEVISION ENGINEER

$$y_1 = \frac{a}{\sqrt{2}} \left\{ \sin \omega t \sin \alpha + \sin (\omega t + \pi/2) \cos \alpha \right\}$$

This light must now be resolved in the plane of vibration of the analysing Nicol, and as this is inclined at 45° to the vibration directions of the quarter-wave plate, we have,

$$A = x_1 \cos 45^\circ + y_1 \sin 45^\circ = \frac{x_1 + y_1}{\sqrt{2}} = 0.$$

This shows that extinction takes place for any angle between the polariser and the analyser.

Light Intensity and Circular Polarisation

Our next step is to determine the intensity of light passing through this circular polariscope when the stressed material is introduced. The problem actually resolves itself into one in which we have to consider the effect of superposition of three crystalline sections, but as we have shown that in the circular polariscope any effect is independent of the angle between the polariser and the analyser, then it will simplify matters greatly if we take the case in which the inclination of the vibration directions of polariser and analyser is zero. The Nicols will be parallel for this position.

Let the light passing through the polarising Nicol be represented by the expression

$$a \sin \omega t$$

Then on resolving the light in the vibration directions of the polarising quarter-wave plate, we have, for the light entering the plate (see Fig. 3)

$$x = a \sin \omega t \cos 45^\circ$$

$$y = a \sin \omega t \sin 45^\circ.$$

On emerging from the plate a phase difference of π/2 has been introduced into the vibration in the OX, the fast, direction. So that the emerging light is given by the expression

$$x = \frac{a}{\sqrt{2}} \sin (\omega t + \pi/2)$$

$$y = \frac{a}{\sqrt{2}} \sin \omega t.$$

Let OX' and OY' be the vibration directions of the stressed material disposed between the two quarter-wave plates; let OX' be the fast

direction and let this direction make an angle φ with the fast direction of the first quarter-wave plate. Then on resolving the light in the vibration directions of the stressed material we have,

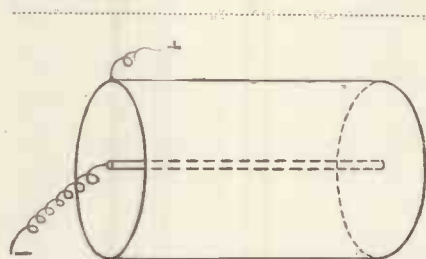

Fig. 4.—Form of cell electrodes.

$$x_1 = \frac{a}{\sqrt{2}} \left\{ \sin (\omega t + \pi/2) \cos \phi + \sin \omega t \sin \phi \right\}$$

..... fast direction

$$y_1 = \frac{a}{\sqrt{2}} \left\{ \sin \omega t \cos \phi - \sin (\omega t + \pi/2) \sin \phi \right\}$$

But when the light leaves the material a further phase difference of δ has been introduced in the fast direction, therefore on emergence we have

$$x_1 = \frac{a}{\sqrt{2}} \left\{ \sin (\omega t + \pi/2 + \delta) \cos \phi + \sin \omega t + \delta \sin \phi \right\} = P$$

$$y_1 = \frac{a}{\sqrt{2}} \left\{ \sin \omega t \cos \phi - \sin (\omega t + \pi/2) \sin \phi \right\} = Q$$

We have now to resolve these two vibrations in the vibration directions of the second or analysing quarter-wave plate. As these latter directions are parallel to those of the first plate, then OX'' and OY'' are coincident with OX and OY. Therefore the light on entering the second plate is of the form

$$x_{11} = P \cos \phi - Q \sin \phi$$

$$y_{11} = P \sin \phi + Q \cos \phi$$

which when expanded becomes

$$x_{11} = \frac{a}{\sqrt{2}} \left\{ \sin (\omega t + \pi/2 + \delta) \cos^2 \phi + \sin (\omega t + \delta) \sin \phi \cos \phi - \sin \omega t \sin \phi \cos \phi + \sin (\omega t + \pi/2) \sin^2 \phi \right\}$$

$$y_{11} = \frac{a}{\sqrt{2}} \left\{ \sin (\omega t + \pi/2 + \delta) \sin \phi \right\}$$

$$\cos \phi + \sin (\omega t + \delta) \sin^2 \phi + \sin \omega t \cos^2 \phi - \sin (\omega t + \pi/2) \sin \phi \cos \phi]$$

and which, after passing through the plate and suffering further phase difference of π/2 in the fast, OX'', direction becomes

$$x_{11} = \frac{a}{\sqrt{2}} \left\{ \sin (\omega t + \pi + \delta) \cos^2 \phi + \sin (\omega t + \pi/2 + \delta) \sin \phi \cos \phi - \sin (\omega t + \pi/2) \sin \phi \cos \phi + \sin (\omega t + \pi) \sin^2 \phi \right\}$$

$$y_{11} = \frac{a}{\sqrt{2}} \left\{ \sin (\omega t + \pi/2 + \delta) \sin \phi \cos \phi + \sin (\omega t + \delta) \sin^2 \phi + \sin \omega t \cos^2 \phi - \sin \omega t + \pi/2 \sin \phi \cos \phi \right\}$$

Finally, we have to resolve these two vibrations in the vibration direction of the analysing Nicol in order to determine the light leaving the polariscope. It will be remembered that in the circular polariscope the vibration direction of the analysing Nicol is inclined at 45° with the quarter-wave plate, so that the vibration in this direction will be

$$A = x_{11} \cos 45^\circ + y_{11} \sin 45^\circ = \frac{x_{11} + y_{11}}{\sqrt{2}}$$

On expansion this becomes

$$A = \frac{a}{2} [\cos (\omega t + \delta) \sin 2 \phi - \sin (\omega t + \delta) \cos 2 \phi + \sin \omega t \cos 2 \phi - \cos \omega t \sin 2 \phi].$$

Collecting the coefficients of sin ωt and cos ωt we have,

$$A = \frac{a}{2} [\sin \omega t (\cos 2 \phi - \cos \delta \cos 2 \phi - \sin \delta \sin 2 \phi) + \cos \omega t (\cos \delta \sin 2 \phi - \sin \delta \cos 2 \phi - \sin 2 \phi)].$$

The intensity of the light is the sum of the squares of these coefficients, so that

$$I = \frac{a^2}{4} \left\{ [\cos 2 \phi - \cos (2 \phi - \delta)]^2 + [\sin (2 \phi - \delta) - \sin 2 \phi]^2 \right\}$$

$$= \frac{a^2}{4} (2 - 2 \cos \delta)$$

$$= a^2 \sin^2 \delta/2.$$

This informs us that the intensity of the light is quite independent of the

(Continued on next page.)



# With Other Listening Posts

Another interesting report from B.R.S. 1295, John Preston of Muirkirk, Ayrshire, who mentions the possibilities of DX on 1.7 mc.

RECENTLY I have been listening most on the 1.7 mc. band in the late evenings. This particular band has a fascination for me and reception of 6-10-watt stations gives me more of a thrill than reception of VK<sub>2</sub>ME or VUB.

It seems to me that the DX possibilities of this band have never been sufficiently investigated, for it is generally assumed that the 1.7 mc. is a purely local band, but this is far from the truth.

I have listened to 2VQ making a contact at 1,500 miles on this band, and at the present time this "Very Quiet" gentleman is slipping across to U.S.A. in the early mornings. 5NW has been reported a good signal in the Canary Islands, as also has 6AU and 2JG. Various G stations have been reported in Germany, Holland, Denmark, etc. I heard 2LZ one night working OZ<sub>2</sub>H on this "local" band. The regularity with which Scottish stations 6SR, 6UU and 5NW work stations in Kent, Essex, Herts and London is remarkable.

Recently 6SR and 5PB, of New Milton, Hants, have reported each other at R<sub>9</sub>, and similar QRK's have been recorded by 5ZJ, 6GO and 5MM.

During the last two years, I have missed few nights on 1.7, and one outstanding thing is worthy of being recalled. Early this winter when following 2LZ and 2VQ in various tests I was knocked all of a heap when W<sub>1</sub>DIK, of Rhode Island, jammed 2VQ. This is not a tall tale but a sober statement of fact which can be vouched for by other stations.

These remarks refer to phone only, as I do not copy CW. Ignorance is responsible for that—and advancing

years. My QRA is in the south-west of Scotland and on the simplest of receivers I have 100 per cent. reception of stations in Kent, Essex, East London, and Herts. Still further south there are five "Paris Brussels" and 2 "X-Ray Canada," who are very well received.

There is, of course, plenty of QRM from trawlers, but there is QRM on all bands. 1.7 is no worse than others and is certainly much better than 7 mc. on Sunday mornings.

I have mentioned 5ZJ and in justice to this station I must say that for a newcomer his progress has been remarkable. A month ago he was unknown, but today he is amongst the leaders on 1.7 and an R<sub>9</sub> signal in Scotland.

In contrast to this station I would mention 2KT, who commenced transmitting shortly after the Norman Conquest, and to-day is still able to keep pace with the fast moving younger generation. "Uncle Nick," as he is affectionately dubbed, and his vis-a-vis, "The Admiral" 6KV, have proved occupancy on 1.7 and incidentally have provided much merriment to offset the eternal round of QRK, QSA, QRM, QRN, and QSB.

2 Don Q has been silent of late, but when working he can put up as good a show as 2LZ, 5MM or any of the Kent and Essex stations. 6RQ, 6TQ, 5IL, 5WL, 2WG, 2OV, 5RD, and that lively Liverpoolian 6OM have all done much to popularise the 1.7 and recently 6VK of Bristol and the northern station 2PO have put across some remarkably fine records.

I hope I have said enough to show that this Cinderella of the ham bands can be as interesting as any of her

sisters, and that it is not strictly true to call it a band for local contacts only.

April was marked by great activity on the 3.5 band. 5VL continues his triumphant progress in W and VE and reception of W and VE over here has been as good as at any time this winter. It is comparable with the fine reception which is being had on 20 metres between 18 and 22 hours.

The fine conditions may be understood when I say that R<sub>8</sub> and 9 signals from VE and W's have been common this week, between 23 hours and 01.00. The last VE has been VE<sub>1</sub>EI, who can be received on a one-valver. Between R<sub>6</sub> and R<sub>7</sub> have been VE<sub>1</sub>DY, VE<sub>2</sub>DX, VE<sub>2</sub>AD, VE<sub>1</sub>CL. W's who have been well heard include W<sub>2</sub>AGA (Uncle Dave, of Albany, New York), W<sub>2</sub>CQN, W<sub>3</sub>SL, W<sub>8</sub>LAC, W<sub>1</sub>LI, W<sub>1</sub>EOP, W<sub>4</sub>NC, W<sub>2</sub>CUM, W<sub>1</sub>ADY.

VE<sub>1</sub>ET intimates that the Canadian amateur-band has been extended to include the frequencies 3,850-4,000 kc, and says that in future most VE's will operate there.

G stations who have provided fine reception on 3.5 are 6SR, 5MM, 6LI, 6OM, 5FB, 5OG, 6MN, 5VL, 2AX, etc.

W<sub>1</sub>EOP, of Callas, Maine, has been heard calling G<sub>2</sub>MO, of London, and VE<sub>1</sub>DY has been thanking SWL and BRS for fine reports. He has especially mentioned Mr. Edwards, of Sutton Coldfield, Warwickshire. This Canadian station asks for reports from British Isles and will send QSL to all those sending such.

Here is some information for the G's operating on 20 metres. Keep to the frequencies 1,430-1,450 kc. where it is clear of W, QRM. This information comes from one of the most successful G DX-ers.

## "The Circular Polariscope"

(Continued from preceding page.)

azimuth of the vibration directions of the stressed material, and therefore of the electrostatic stress directions.

### A New Type of Kerr Cell

With the aid of this form of polariscope it will be obvious that a new field for construction of the Kerr cell is opened up. It is possible now to construct a cell in which one electrode is a metal cylinder and the other is a co-axial wire within the cylinder as in Fig. 4. In this design the fast vibration direction is coincident with any radius of the cylinder. But the plane containing

these directions is normal to the direction of the light path.

The circular polariscope can also be used if it is desired to study the disposition of the achromatic surfaces of uniaxial and biaxial crystals in convergent light without the presence of the isogyres or achromatic lines. Another well-known use for this type of polariscope is in connection with the study of mechanical stresses in various members in building structures, the members being first constructed of celluloid (see Coker and Filon, "Photo Elasticity").

A photograph of the polariscope in actual use is shown. The circular analyser is seen on the left. In this case the quarter-wave plate has not

been cemented to the Nicol. Just to the left of the cell there is a compensator of the Babinet type, whose function it is to determine the retardations of different liquids employed in the cell.

## SUMMER LECTURE COURSE

London students will be interested to know that a course of six lectures on Television Advance will be given at The Borough Polytechnic, Borough Road, S.E., commencing Thursday, May 9, at 7.30 p.m. The course is a continuation of the course normally now ended, but is continued at the special request of the students with the permission of the Principal.

# 240-LINE PICTURES WITH A 30-LINE MIRROR-DRUM

By Bernard H. Dakin

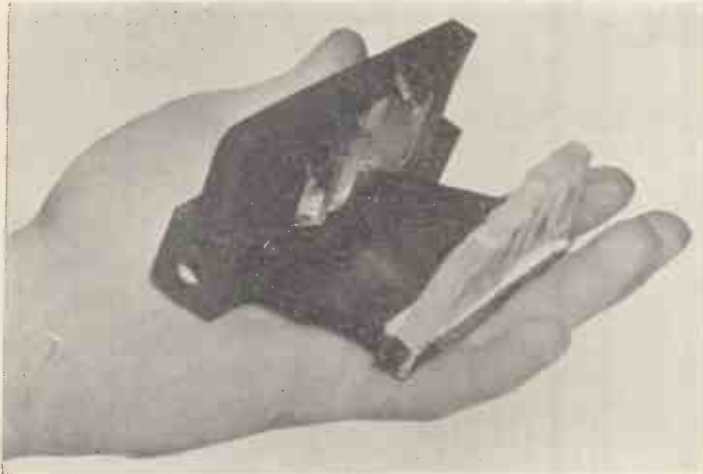

Fig. 2.—The approximate size of the ray divider unit will be apparent from this photograph.

IT is often assumed that high-definition pictures are of necessity produced by a cathode-ray tube, but many experimenters will not wish at this stage either to go to the expense of such a tube or spend time on time-base circuits, etc., if they already have low-definition mechanical apparatus and perhaps electrical equipment which can be progressively improved.

Now anyone who has attempted the construction and adjustment of multi-line mechanical scanners operating directly will realize that it is a very tedious business and therefore it is desirable to use some system which uses a few lines many times.

The kind of apparatus about to be described was evolved to work with a 30-line mirror-drum which so many experimenters already possess. It has been pointed out elsewhere that such a mirror-drum could be used for multi-line scanning by adopting a mirror-multiplier, i.e., a row of six or eight (according to the number of lines desired) mirrors, adjusted so that as each patch of light passes over them it produces six (or eight) lines of the scan instead of a single line. Since this arrangement consists of mirrors which reflect the light, it is necessary to make its path oblique in order that the "multiplied" rays shall not be obstructed by the mirror-drum. This obliquity causes all sorts of difficulties in arranging that the lines shall fall exactly in the correct positions on the screen, so that it is much preferable to use a prism ray-divider as here described.

The arrangement is shown in plan in the diagram. The drum, of course, has its spindle vertical to suit horizontal line scanning. The dotted

line AB shows the axis of the optical (and modulating) system. C is the mirror-drum—adjusted to a ratio of eight times (in the direction of a line) that of the desired high-definition picture ratio. D is the prism

form at a reasonable price. E is an associated row of adjustable-inclination glass plates, that is, a row of eight plates, the first of which are inclined (by the different amounts required) toward the drum in order to

Fig. 1.—A plan view showing the relative positions of ray divider and mirror-drum for horizontal scanning.

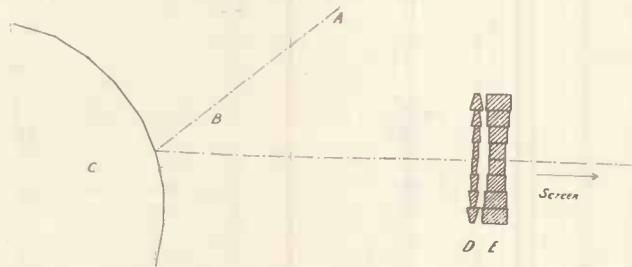

"ray divider"—a series of small angle prisms across which each patch of light in passing is made to go across the screen in eight contiguous lines; this it is hoped will shortly be marketed in a completely adjusted

raise (i.e., displace upward) by the appropriate amount the rays passing through them to make the top lines of each "bundle" of eight lines while the last plates are inclined (by

(Continued on next page.)

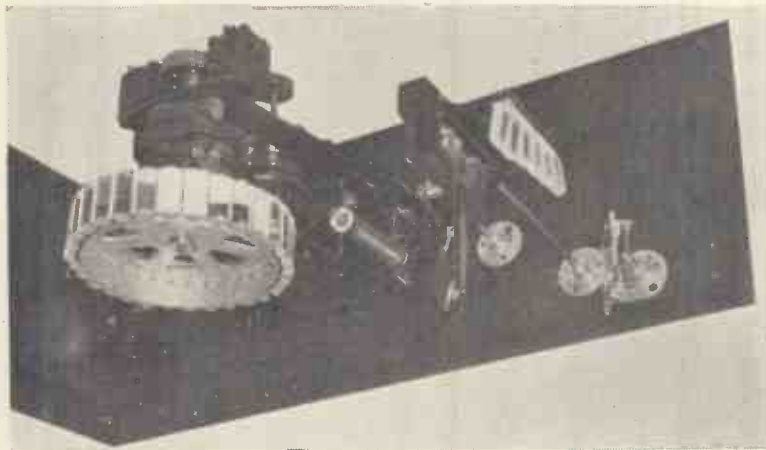

Fig. 3.—This photograph shows the assembly of the mirror-drum receiver including the ray divider or vertical scanning.



# An Experimental 5-Metre Transmitter

IT is probable that there will be a considerable revival in interest in 56-megacycle working during the coming summer. For local contacts the 160-metre band has been used for some

be taken in the construction of the modulator.

As regards the oscillator, it is advisable to mount the two valves away from the baseplate on supports and to connect L<sub>1</sub> and L<sub>2</sub> without any intermediate wiring. The .00005-mfd. anode tuning condenser is of the Eddystone 900 type and a coil consisting of five turns of 14-gauge wire ½-in. diameter

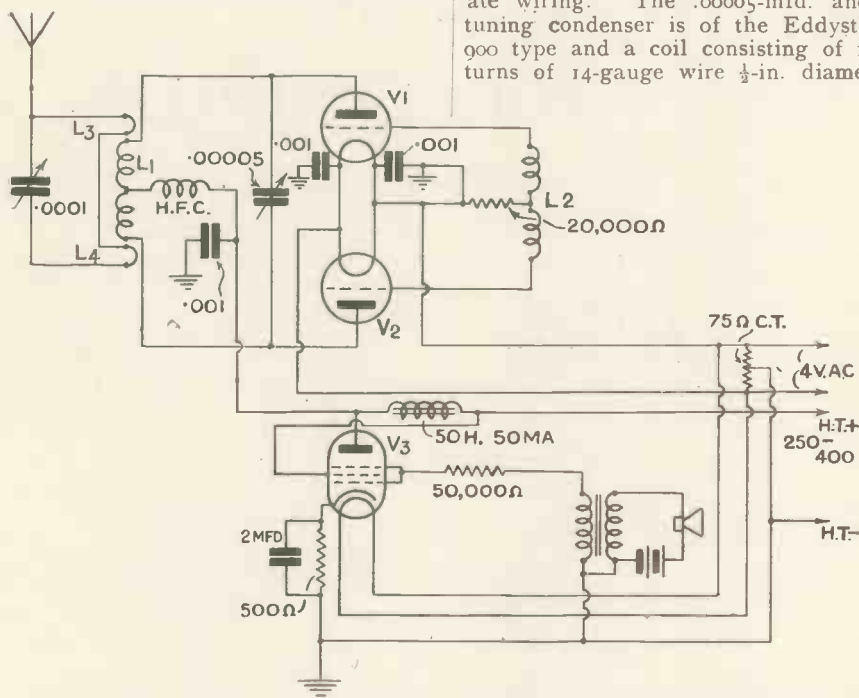

This modulated five-metre transmitter is very stable in operation. The 200 miles record set up last year used a fundamentally similar circuit.

years, but owing to the increasing amount of QRM on that band and the unreliable results after dark, amateurs are endeavouring to find a more simple means of effecting local contacts.

It has been realised that a five-metre transmitter will provide quite reliable results up to 40 miles and with a little luck this range can often be very considerably increased.

Last year we experimented with a circuit based upon the suggestion of the Tungram Valve Co., which used two Tungram P4100's as push-pull oscillators and a multi-grid valve of the APP4120 type as a modulator.

As can be seen from the theoretical circuit, the entire equipment is of the very simplest kind and can be constructed without much difficulty. The speech amplifier is exceptionally small and ample modulation is obtained when using a microphone of the single-button type.

Both the microphone transformer and the modulation choke have to be screened; otherwise no precautions need

will connect across the two condenser terminals quite nicely

The inductance L<sub>2</sub> should be connected across the grid of V<sub>1</sub> and the grid of V<sub>2</sub>, so when fixing the positions of these valves arrange that the distance between the two grids is equal to the length of the inductance L<sub>2</sub>.

Only one high-frequency choke is required and this can be wound on a ½-in. test tube; it should consist of 50 turns of 26-gauge double-cotton covered wire wound solenoid fashion.

The only point which might bother the home constructor is the fixing of the inductances L<sub>3</sub> and L<sub>4</sub>. If all of the tuning condensers are to come to the front and be arranged symmetrically then some artificial means of fix-

ing must be arranged for these inductances.

On the other hand, if the .0001-mfd. aerial tuning condenser is mounted close to L<sub>1</sub> then the outside windings of L<sub>3</sub> and L<sub>4</sub> can be actually connected across the aerial tuning condenser. L<sub>3</sub> and L<sub>4</sub> are both one turn each and half-inch diameter and they must be arranged so that the coupling between them and L<sub>1</sub> is reasonably tight.

One of the most effective means of radiating is to erect a vertical aerial of approximately half-wavelength. A piece of copper rod, providing it is firmly clamped, will do excellently.

A horizontal di-pole can also be used, and in many ways this type of aerial is to be preferred to the half-wave vertical aerial. A di-pole can be erected much more easily and if each half is quarter-wavelength will not take up very much space.

The down feeders consist of lamp flex and unless they are kept comparatively short, they will have to be series tuned, in which case the .0001 condenser, parallel tuning L<sub>3</sub> and L<sub>4</sub>, will have to be omitted.

During our experiments we obtained our high-tension supply from a Rothermel Gen-e-Motor. This gave 250 volts at approximately 65 milliamps enabling us to obtain quite a healthy wattage. As the converter runs from a 12-volt accumulator it is ideal for portable work, so we can recommend the whole equipment for the serious attention of amateur experimenters.

We should like to point out that even though the apparatus is very simple it is essential to obtain a Post Office radiating licence for its use.

"240-line pictures with a 30-line Mirror Drum."

(Continued from page 281)

the different amounts required) away from the drum to lower (i.e., displace downwards) the bottom lines of each "bundle."

Fig. 2 shows a photograph of such an arrangement intended to produce a 180-line scan with a 30-line mirror-drum. The six prisms and six plates are clearly visible. Fig. 3 shows the complete layout.

For a picture-frequency of 25 per second the motor will have to run at 1,500 r.p.m.—just double the usual speed for 30-line pictures, but since a series-wound motor with large resistance is almost universally employed, this presents little difficulty. One can even use an existing motor with its spindle horizontal with a twisted-over belt to a pulley on the vertical mirror-drum spindle.

It need hardly be stressed too much that care must be taken with accurate adjustment and balance of the drum:

READ TELEVISION  
& SHORT-WAVE WORLD  
REGULARLY



MAY, 1935

# Beat-frequency Oscillators

*Very few commercial super-hets embody any means of beating up C.W. transmissions. This automatically precludes the receiver being used by the serious amateur unless some means of heterodyning is easily possible. Here are some details showing it can be done.*

USING a beat oscillator in conjunction with the intermediate-frequency amplifier of a super-het receiver for reception of unmodulated code is quite a conventional idea. However, the introduction of receivers not using automatic volume control very considerably simplifies the addition of the beat oscillator.

With the really modern super-het

the first one, which would be left without any A.V.C. control.

A circuit that really will overcome these troubles and provide a ready means of beating up C.W. signals of all strengths is shown in Fig. 2. When the beat oscillator signal is introduced into the diode circuit, it will operate equally well on strong or weak signals. The strength of the signal from the beat

The use of a stronger signal on the beat oscillator is not necessary, even though a stronger signal does not reduce the sensitivity of the receiver where the high-frequency amplifying valves are self-biased.

Stray voltage feeding from the beat oscillator to the input of the intermediate-frequency oscillator must be small, as the amplification of this stray pick-up is dependent on the strength of the incoming signal.

The amount of stray pick-up is also to a large extent dependent on the arrangement of the I.F. amplifiers and whether or not a filter is used in the anode circuit of the oscillator. This filter circuit is shown in Fig. 2, where it is in the high-tension positive lead to the final I.F. amplifier.

It is an excellent arrangement to combine the transformer feeding the diode circuit with the primary and secondary coils of the oscillator. The grid blocking condenser of the oscillator section can also be mounted inside the coil, for this reduces stray pick-up into the I.F. amplifier.

A trimmer actually mounted on to the I.F. can be used to tune the beat oscillator, while a standard type twin trimmer of the Cyldon type can be used to trim the primary and secondary of the transformer.

It is most important that the beat oscillator is not tuned to the fundamental frequency, otherwise it will cause serious absorption and loss in signal strength. So it is advisable to tune the oscillator to the harmonic—either the second or third—it is immaterial which. This, in addition to preventing loss in signal strength, enables the oscillator to operate very strongly without producing too strong a signal.

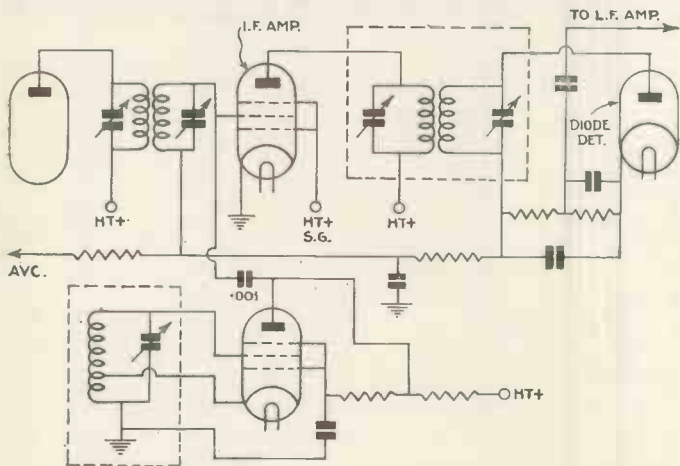

Fig. 1.—By feeding the output from a beat note oscillator into the grid of an I.F. amplifier, C.W. reception is considerably simplified. No super-het receiver without an oscillator of this kind is suitable for C.W. reception.

with two or more stages of intermediate-frequency amplification and A.V.C. voltage applied to all grids, complications generally arise. What actually happens is that the beat note is absolutely inaudible when signals over a certain level are received. This does not matter very much when the receiver is insensitive, for as a general rule none of the C.W. signals would rise over a low strength level.

As a matter of interest we have illustrated the connections for the simplest type of beat-frequency oscillator coupled to the intermediate-frequency amplifier. This is in Fig. 1.

It will be seen from the circuit that the strength of the beat oscillator signal applied to the second detector is dependent on the amplification of the preceding valve. Where this valve is A.V.C. controlled, a strong signal will reduce the amplification, so the beat-frequency oscillator either produces a weak note or is inaudible altogether.

If the strength of the beat oscillator is increased to overcome this then it is likely to operate the A.V.C. and make the receiver insensitive to weak signals. Of course, it is possible to have two stages of intermediate-frequency amplification and A.V.C. only on the second one, injecting the beat note into

oscillator will be sufficient to draw from 4-8 micro-amps. direct current in the diode resistance.

Under these conditions the beat oscillator will not develop sufficient A.V.C. voltage to reduce to any appreciable extent the overall sensitivity of the receiver. As a matter of experiment a diode resistance of greater than 100,000 ohms can be used, the signal from the beat oscillator being adjusted to a proportionately less current flow through the diode resistance.

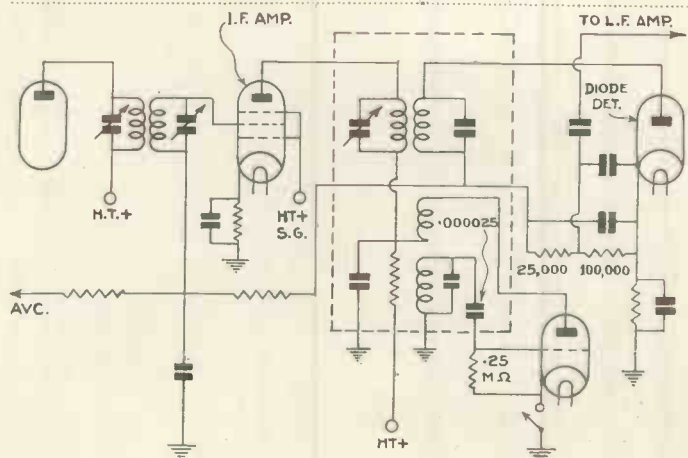

Fig. 2.—In this arrangement it is important that the beat note oscillator be tuned to a harmonic of the C.W. station and not to the fundamental. By introducing the oscillator signal into the diode circuit no complications are set up when automatic-volume-control is applied to the I.F. or H.F. stages.

# W9BHT, Canton, Ill., U.S.A.

*This famous American amateur station is well known to short-wave enthusiasts all over the world. It is completely up to date and uses all the latest refinements. The operator is W. Ingersoll.*

W9BHT is situated in the centre of Illinois and about three miles from Canton. The actual building was originally a farm house, built eighty years ago. It has been remodelled to include a third floor solely for the transmitters and other radio gear.

In the accompanying photograph the operating table, turn-tables, recording equipment, cathode-ray checker, transmitters and modulator can be clearly seen.

The transmitter has been designed to operate on all amateur frequencies with either phone or C.W. In the radio-frequency portion there is a type 47 oscillator, followed by a 47 doubler or buffer, a second sub-amplifier using a 210, with a third sub-amplifier stage using a 03A. In the final P.A. a pair of 150T valves are driven to 1,000 watts.

A condenser microphone is used and this is coupled to a pair of 56's which in turn are coupled to another pair of 56's. The output from this stage is fed through a 500-ohm line to a pair of 845's which drive a pair of 849's in class B as modulators.

Bias for the entire transmitter is obtained from the mains, the actual mains unit including a pair of 5Z3 rectifiers in parallel. An auto-transformer mounted behind the main transmitter enables the anode voltage applied to the P.A. stage to be adjusted at will. This transformer also varies the bias in sympathy with the H.T.

From the operating table it is possible to control the complete transmitter by means of four switches. The first switch controls a relay which turns on all filament voltages as well as the time delay switch for H.T.

Next is the switch controlling a relay to apply H.T. for the modulator and P.A. The third switch is actually the master control. In one position all high voltages are cut off and in the second position the receiver is switched on ready for operation.

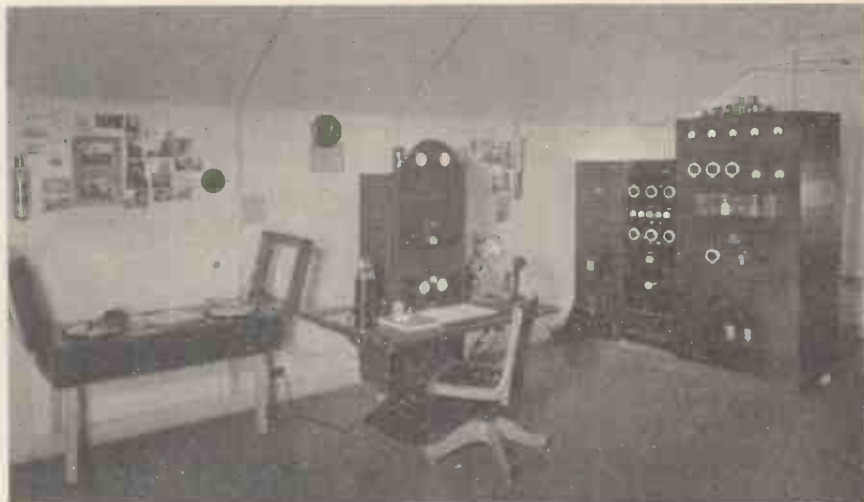

*From left to right will be seen recording gear, electric gram-motor and pick-up, radio receiver, mixing panel, cathode-tube monitor and ribbon microphone, and finally the all-wave band transmitter and class B modulator.*

On the operating table is a RME-9-D receiver, a mixing panel and a pre-amplifier. The microphone is A.C.-operated with the power supply beneath the table. It is also possible to mix two microphones, the receiver or pick-up as required.

Two turntables can be seen in the photograph. One is for the playing of records while the other enables any received transmissions to be recorded and played back almost at once.

On the top of the operating table is an electric clock, on the left-hand side, and a cathode-ray tube on the right-hand side. This tube is used to check the

entire transmitter for all defects. It is also used in checking amateur phone stations, for a pair of plates in the tube are connected to the last I.F. stage of the receiver for R.F. waveform to be checked. The other plates are connected to the low-frequency end of the receiver in the usual way.

This station is one of the finest in America at the moment and probably accounts for so many B.R.S. listeners having heard it at R9 plus. It is perhaps the most worked station on 20 metres and the voice of the operator, Bill Ingersoll, is familiar to many transmitters.

## When to Listen for Short-wave Stations during MAY

By 2BWP, C. J. Greenaway,

B.S.T.	3.5 mc.	7 mc.	14 mc.
0100		W4	W8
0300	W8		
0400	W1, 2, 8		
0500	VE1; W1, 2, 3, 4, 8	W1, 2	
0600	VE1; W1, 2, 3, 4, 8	CM; K4; VE1; W1, 2, 3, 4, 5, 8, 9	W6, 7
0700	W8	HC; VK; W1, 2, 4; YV; ZL	W6, 7; K6
0800		FM4, 8; VK; W4; ZL	
0900		ZL	SU; W3, 6
1700			CT3; SU; ZC6
1800			CN; VQ5
1900			CT3; FM4, 8; J; LU; W1, 8
2000			FM8; J; LU; PY VE1, 3; VP6; VQ4; W2, 3
2100			FM8; LU; PY; SU; VE1, 2, 3; W1, 2, 9
2200		CT3	CE; CM; CX; FM8; LU; NY; PY; SU; VE1, 3, 4; W1, 2, 3, 4, 8, 9; YV
2300		FM8; W2	CE; CT3; FM8; HP; K5; LU; PY; TI; VE1, 3; VP6; W1, 2, 3, 4, 8, 9
2400		W4	



# DEFINITION AND VIEWING DISTANCE

By J. M. Bartlett, B.A.

ANY people appear to think that a picture of about 10 ins. is absurdly small and that it will be impossible to see much detail in a picture of such a size. They expected pictures at least 2 or 3 feet square and imagine with only some 10 ins. square the detail will be in no way comparable with that seen in a cinema. That this is a fallacy it is hoped to show by the following reasoning.

## Distance and Detail

We have first to understand the important physiological fact that, at a given distance from a given object, there is a definite limit to the amount of detail the eye can see. This can be proved very easily by considering

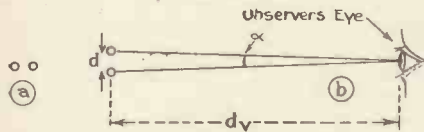

Figs. 1a and 1b Diagrams illustrating the optimum viewing distance.

an ordinary coarse newspaper photograph. If it is held very close to the eye, we can clearly see the separate little black dots of which it is composed, while if it is withdrawn to some considerable distance we might be completely unaware that it is not an ordinary photograph with no dots at all. Obviously any extra detail, represented by still more dots in between those already there, will not be seen when the picture is viewed from the latter position, and is superfluous from that particular viewing distance.

Artists always take advantage of this fundamental principle. Any painting examined closely appears coarse and unreal. In fact, when viewing a picture, one almost automatically adjusts oneself to a distance where one sees as much detail as possible, without, to revert to the newspaper analogy, "seeing in between the dots."

Let us put this into more scientific language. Suppose the two dots which might be part of a newspaper photograph in Fig. 1(a) be viewed from a continuously increasing dis-

tance until they just appear to merge together. This point is known as the "optimum viewing distance." If they are spaced further apart, we must move further away for them still to merge. Thus there is a constant relationship between the distance between the dots and the optimum viewing distance.

It is found that the angle in Fig. 1 (b) which the dots subtend at the eye is always the same at the optimum viewing distance. It may vary slightly for different observers, but a good average figure for the purposes we shall be discussing is 1/30th of a degree, or two minutes. Expressed mathematically, we can say,

$$d = .00058d_v$$

where  $d$  = distance between dots, and  $d_v$  = viewing distance.

As an example, if  $d_v = 50$  feet,  $d$  will be .348 inches, meaning that detail closer spaced than this will be invisible from that distance.

## Scanning Detail

Considering now the case of television scanning where the scene is divided into strips, it will be understood that the process of scanning imposes an immediate restriction on the possible detail. Fig. 3 shows a scanning spot moving along a strip of the image. No detail within the spot can be reproduced. If the spot were large, it might cover our two dots, or a person's eye or mouth, but none of it would be reproduced as such. It would just blur over the detail into a uniform tone value. Consequently, there is nothing whatever to be gained by viewing a television image at a distance which would

enable one to see detail, were any there, smaller than the spot.

## Optimum Viewing Distance

Thus we deduce that the "optimum viewing distance" for watching a television image is such that the width of a scanning line corresponds to the length " $d$ " in the formula quoted. If we view it nearer, we shall see the line structure, and further away some detail will be lost.

Now suppose we have a cathode-ray tube which projects a picture 10 inches square with 240 scanning lines (the number suggested by the

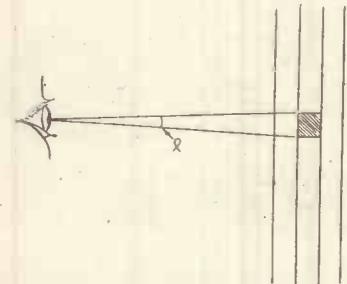

Fig. 2.—Diagram showing how detail is dependent upon both scanning spot size and viewing distance.

Television Committee for the new high-definition system), the width of each line will be 1/24th of an inch, and by applying the formula we get  $d_v = 72$  inches, or 6 feet, which is a viewing distance convenient for the average room.

We wish to know if we shall see as much detail as in a cinema screen. For purposes of comparison we must make certain assumptions as to average conditions. We will suppose a cinema screen 12 feet high viewed from a distance of 90 feet—fairly reasonable figures. From the formula, it is found that  $d = .00058 \times 90 = .0522$  feet. This means that if the picture were a television image made up of scanning lines, the minimum line width needs to be .0522 feet (or .6264 inches), so that the minimum total number of scanning lines to form the image would be 12 feet divided by .0522 = 230.

The conclusion we draw is that a home television receiver with an image of 240 lines, 10 inches square, will give just as much detail, and therefore potentially as much entertainment, as one gets from an average seat in an average cinema.

TELEVISION  
AND  
SHORT-WAVE WORLD

- Month by month *Television and Short-wave World* is the publication that will keep you abreast of the many developments that are taking place in television and allied subjects.
- Order your copy to be delivered regularly.



# Noise Suppression

By G5ZJ

## on the Top Band

JUST recently, interference and general QRM on the top band has been getting steadily worse. At the moment, conditions are so bad after dark that long-distance contacts are almost impossible.

If the troubles are segregated, they can be divided up into four groups. (1) The bad QRM from trawlers and the harmonics from the medium-wave broadcasters; (2) the high noise level in the receiver; (3) night distortion on all stations over a certain distance; (4)

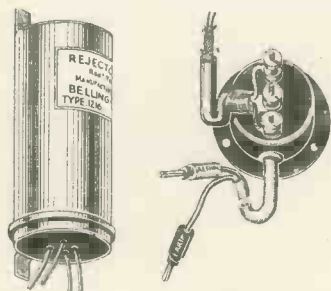

On the left is the first impedance matching transformer connected close to the aerial at the top of the mast. The second transformer is fitted to the receiver chassis.

local interference from domestic appliances or motors, etc.

Of these, four troubles only two can be reduced or eliminated. These are the harmonics from the medium-wave broadcasters, and the local interference from electric appliances.

I do not propose to deal with the elimination of harmonics, for this is quite simply done with a wavetrap. Actually a series coil in the aerial lead if tuned to the fundamental of the offending medium-wave broadcaster will cut out all but the strongest harmonic. I found that it was essential to cut out as much interference as possible for every little helps.

The high noise level can often be reduced if the volume control on the receiver is reduced as well. This can only be done if the station is at good strength and there is not any need to boost strength to overcome local interference or other QRM. So it will be seen that any reduction in noise, no matter what kind, will help to bring in the long-distance stations.

Broadly speaking, if the local interference can be cut out or reduced the stations will be heard with much greater clarity even if trawler interference is still bad.

Belling-Lee have just brought out a

new noise suppressor which I have tried with great success. It can be erected in the average garden and is quite simple to erect.

I remember G6CT telling me that his reception on the top band was spoiled by QRM from local trams. Here is the very idea to overcome that trouble.

It must be realised that it is not possible to prevent pick-up of interference by an elevated aerial. All that can be done is to make sure the lead-in wire does not increase the pick-up as it comes down past the house or other buildings. Often as the aerial is high up the amount of pick-up from motor cars, for example, some 40 ft. below is very small. The lead-in wire is generally the cause of the trouble. The amount of noise picked up increases towards the ground.

With the Belling-Lee Rejectostat system this is all overcome. First of all the aerial must be erected as high as possible, and if it is known from where the interference originates then at right angles or as far away from it as possible.

It is possible to erect the aerial as far

and screened down-lead will almost be bound to reduce the interference.

The aerial is coupled to a transmission line close to the top of the pole by means of a step-down transformer. This unit transforms the picked-up energy, at aerial circuit impedance, to approximately 1/10 of that value and applies it to both sides of a twin cable or transmission line.

Both conductors in this cable are balanced with respect to earth so that any pick-up on one of the wires is cancelled by a similar pick-up on the other.

This point in addition to the metal screening outside the cable accounts for the fact that with a perfectly erected transmission line there is not any pick-up on the line itself.

The receiver is coupled to the transmission line at the other end in a similar manner. A transformer is again used and increases the impedance of the line to the impedance of the receiver. In extreme cases the transmission line can be buried so as to make quite sure the interference will not be carried on to the receiver.

A direct earth *must* be used as quite

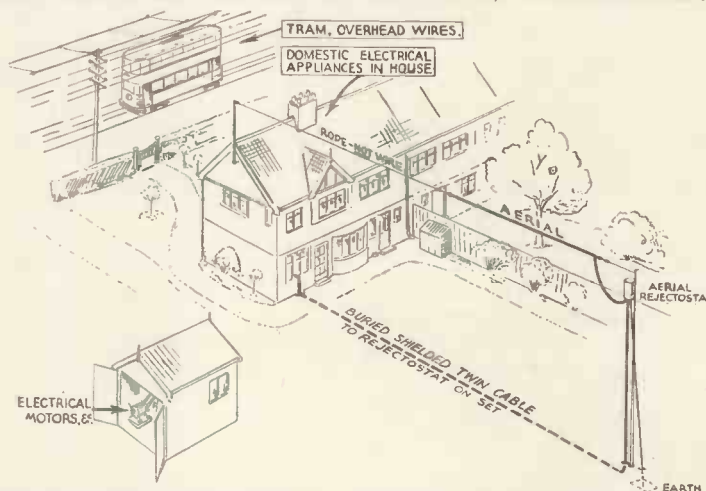

Where the interference is local it is advisable to bury the lead-in wires as much as possible. This is particularly advisable when the interference is from car ignition or small motors.

as 900 ft. away from the source of interference without reducing signal strength. The long lead-in will not affect results even on the very short waves for special matching transformers are supplied which balance out the effect of the lead inductance and capacity.

I have also noticed that the field of a motor car ignition spark decreases very rapidly vertically, but not necessarily horizontally, so the high aerial

often the interference is carried along water pipes or steel girders. A good direct earth will make a big difference to the amount of suppression.

It does seem that this type of noise suppressor is going to help many amateurs to obtain good top-band reception.

The amount of signal loss is fractional and can be discounted in view of the extra readability of long-distance signals.





array of suitable meters. The fact that the meter will read low values makes it very useful.

**An Australian Two-valve Short-wave Receiver.**

We are indebted to B.R.S. 1,374 for details of a two-valve short-wave re-

ceivers. All the constructional details are printed in the January 10 number of the Brisbane paper, the *Queenslander*.

One-half of the class B valve acts as a simple grid detector with the leak across the grid series condenser. The reaction winding is in series with the primary of the intervalve transformer,

tern. This transformer has a volume control across the secondary, the resistance having a value of 500,000 ohms.

Details are also given as to how the coils should be made for the various wavebands. It is suggested that the former used have a diameter of 1 3/4 ins. and be of high quality material.

For the 15-30 metre band five turns for L1 and seven turns for L2 are required. For 26-60 metres fifteen turns for L1 and nine turns for L2 are used, while the final band from 55-100 metres calls for twenty-five turns on L1 and twelve turns on L2.

The components are of standard type

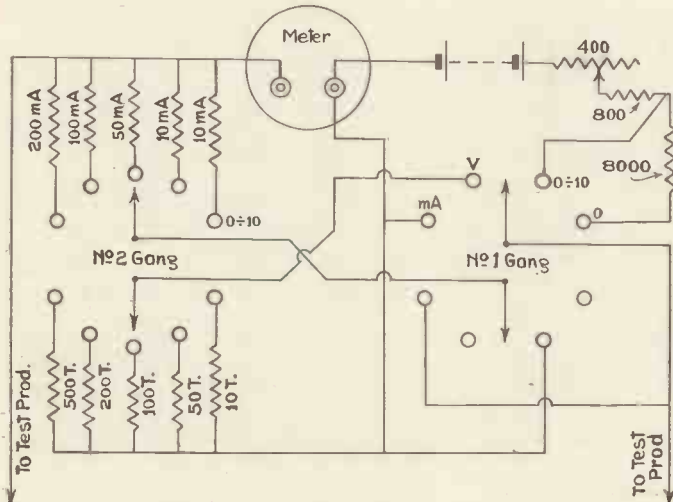

(Left)—A resistance bridge that can be made from standard components is a handy adjunct to the laboratory. This unit is intended for the serious experimenter.

(Right)—A B21 is the type of valve used in this two-in-one circuit. Even though it is novel, the results given are good. It is a fine receiver for the beginner on short waves.

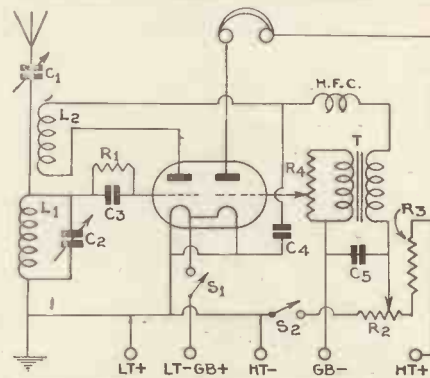

ceiver which has proved popular in Australia.

The idea of using a class B valve to fulfil two operations is not entirely new but in this instance the actual circuit arrangement will prove of interest to

while the amount of regeneration can be governed by the variable resistance R2.

The second half of the valve is then coupled to the detector through a high-ratio transformer of conventional pat-

while the values should be .00025-mfd. for C2, .0001-mfd. for C1, .0003-mfd. for C3; R2 is 25,000 ohms, with a class B valve, such as the Cossor B240. The remaining components are of standard values and are not critical.

## GERMAN TELEVISION RECEIVERS

**F**IVE concerns in Germany are now manufacturing television sets. The Telefunken Company has two types both using high-vacuum cathode-ray tubes. The dimensions of the screens are 15 by 17 centimetres and 23 by 26 centimetres (5.9 by 6.7 and 9.0 by 10.2 inches). The Telefunken Company is the only German company which has a screen material producing a black-white picture.

The cathode-ray tube receiver of the Fernseh A.G. has a screen with dimensions 24 by 30 centimetres (9.4 by 11.8 inches), and is the largest one available in Germany. The reproduction of this television receiver is generally praised as the best of all German receivers.

The television receiver of the Radio A.G. D.S. Loewe also uses a cathode-ray tube. This receiver, with

screen dimensions of only 10 by 15 centimetres (3.9 by 5.9 inches), is the cheapest one on the German market, selling for \$220 to \$270.

The dimensions of the screen of Ardenne receiver are 15 by 17 centimetres (5.9 by 6.7 inches); the colour of the picture is light-green. The ultra-short wave superhet used is worked without a second detector. The rectification of the i.f. impulses is done by the cathode-ray tube.

### A Mechanical Receiver

A very different type of television receiver is made by The Tekade Co. This receiver is a mechanical type utilising the mirror screw. A neon glow lamp is used as the light source controlled by the impulses obtained by the ultra-short wave superhet receiver. The mirrors on the spindle

reflect the light of the neon lamp upon the back of a semi-polished glass plate, having dimensions of 12 by 15 centimetres (4.7 by 5.9 inches).

The German Government, in collaboration with the German radio industry, is now working on a plan to sell these television receivers by instalments. The very successful experiment with the so-called "Folksempfänger" (people's broadcast receivers) that had been sold during the season 1933-34 to the number of 500,000 sets is evidence that co-operation between the Government and the German radio industry is also likely to be successful in popularising television.

### CANADA AND TELEVISION

It is reported that an American television promoter has been subsidised by the Canadian government to erect the first experimental station in Montreal. This is to be 120 lines, mechanical scanning. The apparatus provides for a projected picture 10 ins. by 12 ins.



# A "DE LUXE" CATHODE-RAY TELEVISION VIEWER

## THE DESIGN REVIEWED

*As stated in our issue last month, we are commencing the design of a "de luxe" television viewer and receiver based on the cathode-ray tube. The scanning circuits will be adaptable to the higher definition television when it is established and the design of the receiver will be brought up to date by the publication of a short-wave circuit to fit in the place of the broadcast band receiver in the original. In this article the designer discusses the problems of the layout and circuits.*

**J**UDGING from the comments of readers, the recently-published design for a cathode-ray receiver aroused great interest and formed the basis of several experimental layouts which have given good results. At the same time, we feel that there are a good many of our readers who are hesitating to launch out on the construction of what is a fairly expensive receiver, in the thought that it may be obsolete in a few months' time.

Nothing is more remote than the possibility of a revolutionary change in the television system in the immediate future. Further, whatever change is made in the direction of higher definition can be accomplished with the cathode-ray tube, since it provides such a satisfactory means of high-speed scanning. A cathode-ray tube used on the present transmission will not, therefore, be made obsolete, but will rather be used in a more efficient manner when the standard of transmission is raised.

It is not a difficult matter to so arrange the scanning circuit that the number of lines on the screen can be increased to 180 or 240 by the alteration of one or two simple components. So the television section of the complete receiver can be taken to be up to date for a very long time to come.

With the receiver for sound and for vision we shall not be so fortunate. The high-definition television on short waves will necessitate a complete re-design of these items, but even then there will be no necessity to scrap the existing sets, as they will be serviceable for the ordinary broadcast band. The aim of the design is to enable the alteration to the receivers to be made with the minimum of disturbance to the make-up of the whole set.

A final objection which will occur to everyone—why make up an expensive set which will only be used for an hour or so a week? This argument would have more weight if the

set were only designed for television reception, but the fact that a sound receiver is incorporated in the cabinet means that the owner has the ordinary broadcast programme always available. The cabinet as a whole is not wasted—rather, the value of it will increase with increasing television facilities.

### The Cabinet

The cabinet is an ordinary radio-gram with the speaker grille at the lower part. One of the difficulties in the make-up of a cathode-ray receiver is the disposal of the tube! The overall length of tubes varies, but an average figure can be taken to be 50 cm. (20 ins.), and with this length to be accommodated in the cabinet the depth must be increased to an unwieldy amount or the tube must be adapted to fit in a special way.

If the tube is mounted vertically no alteration to the dimensions of a standard cabinet are necessary, but the lid of the cabinet must be fitted with a mirror for viewing the image and must be adaptable to an angle to suit the line of vision. At no time is it possible to view the image direct without peering in the top of the cabinet.

### Changing the Scanning

When the picture is viewed in the mirror the right- and left-hand sides of the picture are reversed, and due allowance must be made for this in connecting up the scanning circuit. When the tube is viewed direct the scanning is in the wrong direction and must again be reversed to give the correct picture. This is done in a very simple way in the cathode-ray tube by connecting one pair of the deflector plates to a changeover switch, which is wired so that the potential applied can be changed in

polarity. This switch is marked "Direct" or "Mirror," enabling an immediate changeover to be made.

### Power Supply

The tube used in the circuit is the Ediswan type AH with a white screen, giving the nearest approach to realism in the picture. This tube requires 2,000 volts for its excitation, which is provided by a power unit in the lower part of the cabinet. To avoid expense and to keep the high-tension gear as compact as possible this same supply is used for the scanning circuit.

There is thus only one possible source of danger in the equipment, and, provided that care is taken in the wiring and the transformer and rectifier are properly screened, no risk of shock is present.

It is just as well, however, to repeat a warning which has appeared many times in this journal: The voltage used in cathode-ray tube circuits is much higher than that of the ordinary receiving set, and is definitely dangerous. The greatest possible care should be taken in the wiring and the layout of the components, and only tested and proved components should be used in the set.

Adjustments should never be made with the high-tension switched on, and the whole equipment should be protected when it is in use. Provided these precautions are observed there is no risk.

It is often said, and justly, that television is for the entertainment of Londoners. This is true to the extent that the Londoner can always rely on full signal strength for his vision. At the same time the sound accompaniment is more difficult to receive, and what is gained on the roundabouts is sometimes lost on the swings.

The construction of the scanning circuit will be described in next month's issue.

# THE SCOPHONY SYSTEM OF TELEVISION

## IMPORTANT DEVELOPMENTS

**S**COPHONY, LTD., has been registered as a private company with a capital of £140,000 in shares of £1 to take over from a previous company of the same name certain processes and world patent rights in the field of television, cinemato-



*Mr. S. Sagall, Managing Director of Scophony Ltd.*

graphy and commercial communications, which are in the main the invention of Mr. G. W. Walton.

The Board consists of:

- Sir Maurice Bonham Carter, K.C.B., K.C.V.O., Director of O. T. Falk & Co., Ltd., *Chairman.*
- Mr. W. S. Verrells, Chairman of E. K. Cole, Ltd., *Deputy Chairman.*
- Mr. S. Sagall, Managing Director of the old Scophony, Ltd., *Managing Director.*
- Mr. R. E. Cornwall, Director of the London & Yorkshire Trust.
- Mr. O. Deutsch, Director of the old Scophony, Ltd., and Chairman of Odeon Theatres, Ltd.
- Mr. A. Levey, Director of the old Scophony, Ltd.
- Mr. G. W. Walton.
- Mr. L. L. Whyte.

It will be remembered that in the report of the Television Committee the Scophony system was described as "one of the most distinctive" of those under development in this country.

Messrs. E. K. Cole & Co., Ltd., the well-known radio manufacturers, have taken an important interest in

the new company and are represented on the board by their Chairman, Mr. Verrells, and by Mr. R. E. Cornwall. Mr. O. Deutsch, Mr. A. Levey and Mr. S. Sagall represent the former Scophony, Ltd.

The Scophony system is based on the inventions of George William Walton, a Lancashire engineer, whose early television patents date from 1922. Mr. Walton saw the limitations of the Nipkow disc and mirror-drum and set out with the ideal of giving pictures in the home approximating in definition, size and brilliancy, the home cinema. Accordingly he had the courage to break away from previous television conceptions and after many years of arduous work succeeded in evolving an entirely new method of optical representation of pictures. This method is equally applicable in television, cinematography and picture telegraphy.

Some six years ago Mr. Walton became associated on the business side with Mr. S. Sagall, a pioneer of commercial television in this country. It was largely due to Mr. Sagall's unbounded enthusiasm and remarkable persistence that Mr. Walton got his initial financial backing, and the original Scophony, Ltd., was formed. The path of the Scophony Company was, however, very thorny and Sagall and Walton had to struggle along continuously fighting against heavy odds. In spite of these very grave obstacles, the Scophony laboratory, consisting of Mr. Walton and a small band of enthusiastic technical collaborators, succeeded in obtaining excellent results. Truly *projected pictures* of the size of the home cinema are already available. *The Scophony system also holds out the prospect of large screen television for cinemas.*

### The Scophony Receivers

Scophony, Ltd., have already entered the field of manufacture of high-definition television transmitters, and the design of receivers for the proposed London transmission service is well advanced. While it is too early to quote now a price for the receiver, it is anticipated that the price will be definitely competitive.

As has been explained in this journal previously, the basic optical principles of the Scophony system applied in cinematography make available a new type of a one-dimensionally recorded film which could be 1/100th in length of the normal film for the same amount of recorded information. This when applied in practice to the home cinema would make it possible for the amateur to obtain his film, say, at an expense of only 2s. 6d. for five minutes' entertainment, as compared



*Mr. W. S. Verrells, Chairman of E. K. Cole, Ltd. and Deputy Chairman of Scophony Ltd.*

with 30s. for the normal home cinema film.

The fact that the well-known radio concern, E. K. Cole, Ltd., manufacturers of Ekco radio apparatus, have taken a substantial interest in Scophony, Ltd., and are represented on the board of the company by their chairman and one of their directors, is of great significance. Mr. Verrells is a pioneer and built up the Ekco Company from very small beginnings. Ekco employs in its modern Southend factories many thousands of workers. It is interesting to note that Ferranti, Ltd., are also shareholders in Scophony, Ltd. Cinema interests are strongly represented by Mr. Oscar Deutsche, head of the largest independent circuit of cinemas in this country, and of Mr. Arthur Levey, who has wide cinema interests both in this country and U.S.A.



# Heard on the Short Waves

By

Kenneth Jowers



G5LC has worked all continents with this transmitter. Series modulation is used while the P.A. runs at 50 watts C.W. and 12 watts for phone. It is licensed for all amateur bands.

IT seems that this month the only topic of conversation amongst the amateur fraternity is two-way working with 20-metre W phone stations. Even the listening stations are commenting on the exceptional strength of these stations after 20.00 continuing until 23.30 and sometimes later.

Most small super-hets are at the moment bringing in American stations R8-R9 while several readers have logged some of the more powerful transmitters on O-V-1's and O-V-2's.

For example, W. A. Clemenson, of Hampstead, says that the 20-metre band is full of 20-metre phone stations right up until 1 o'clock in the morning. He mentions that W2FLP, using 75 watts, and W2BYJ, with 250 watts, wish to work European stations, and at the same time would like reports from B.R.S. listeners, so will the G stations please give them a call. W6SZY is leaving for Japan in June—I wonder if any G stations will work him from the new QRA.

## Reports Wanted

Another good station being heard well in this country is W7AMX on 7 megacycles, which is on the air from 06.00 to 07.30 with an input of 180 watts. Mr. Clemenson also mentions that HC1FG, Rio Bamba, was received R7 and 20 metres at 23.45. So far his log stands at 93 countries.

I have an excellent QSL card from a receiving station operated by Oliver Derrick and Myles Mackenzie, at Stirling. They again comment on 20-metre phone stations and mention that American stations are receivable even though local omnibuses cause a considerable amount of QRM. Stations which are particularly well heard are

VE1EI, HI7G, W8GIY, VE2EA, W2GOQ and W3QAD.

The 40-metre band in Stirling is apparently only suitable for local reception. Stations heard include G5PP, G5PB, G6PK, G6XR and G6VF. Oliver Derrick wants to know if there are any G stations in his area who contemplate putting out 5-metre transmissions. If so, will they please communicate with him at Gowanhill, Drip Road, Stirling, giving details.

Over 130 stations were received in Stirling using a simple detector and one L.F. receiver, during four weekends only, which seems to confirm what I always imagined, that Scotland is particularly good for DX.

## Reception in Scotland

Another listening station in the same area, B. McDougall, of Glasgow, does not give me such good reports. He finds that the only stations above R5 were G5TZ and G6ZX, although quite a number of F's were coming in R7. I am glad to see that G5MR can be heard so well in Glasgow. This station used to be within two or three miles of me, but has since moved to I believe, Hastings. Mr. McDougall points out that he heard G6ZX and G2XO using a special W code. Are there any amateurs who can check this or know anything about it?

## 20-Metre Stations

B.R.S. 1,448, Eric Wills, of Exeter, finds that in his area, 20-metre stations can be heard during the afternoon, and include W2GRA, W3RN, W1AFU, ZB1G, SU1CF, VQ4CRL, CT3AB, CT1BY. 20-metre phones continue to come over until 22.00 when all Americans are between R5 and R7.

Some later news from this listener mentions that VK2EO, YR5AA, OM2RX, VS1AJ have also been heard. Of the commercial stations VK2ME and VUB, Bombay, are generally R9.

## Commercial Broadcasts

F. A. Beane, of Ridgewell, Essex, is disappointed to find so little space devoted to commercial broadcasters. Well, the reason for this is that as a general rule the commercials vary so very slightly as compared with the amateur stations. Mr. Beane has made some very good logs. He has heard stations such as HJ1ABD, TIEP, TIGPH, PRA8, YV5RMO, YV2RC, YV3RC, and VK3LR. If readers want further information on commercial stations, perhaps they will be good enough to let me know.

B.R.S. 1,353, S. Bradbury, says that conditions are fine on 20 metres in Bradford. Funnily enough only between 21.00 and 23.00. He comments on the strength of the Cuban station CO2HY, and the Canadian VE2BG. In his log I find over 30 stations, all long distance, were received in less than an hour-and-a-half. These include Cuban, Canadian, and American amateurs, so it seems that Yorkshire is O.K. for short-waves, and the reason for my not receiving many reports is perhaps because of lack of interest.

## Japan

J5CE, Japan, has been heard in Stockport by R. H. Jackson. In addition he has worked VS6AQ, W7AMX, and has logged OM2RX, VS6AG, VU2FP, CX1CG, LU1CH, ZD1D, VK3ZF, PY2CA, VP2CE, and VP1AA. Very good going! It seems that Cheshire is a live county; one of the best stations I have worked recently has been 6OM, of Birkenhead.



I have always been given to understand that amateurs in the Birmingham area, besides being very efficient, are a friendly lot. This seems to have been borne out in practice for I receive a lot of very nice letters from that area. Talking about Birmingham, G. Martin, G2LB, would like to exchange station photographs, so anybody who would like a snapshot of G2LB and would care to exchange, please drop a line to 3 Gladys Road, South Yardley, Birmingham.

J. Greenshields, of Burnt Oak, says: "I think your readers would like to know of the extraordinary results I



B.R.S. 1287 uses a simple receiver and has received a large number of verifications. His latest is W1OXDA.

have been getting on 20 metres. The receiver in use is an o-V-1 using two triodes, with a badly screened aerial, 20 feet long. Between midnight and 01.30 I received one or two south Americans, including HI7G at R7. This is the time when the 20-metre band is supposed to be dead."

Amongst the 40 odd stations heard at Burnt Oak, were W4HUT, W3IX, W3VRX, VE4NI, W3GLY, W3CHO, W3VOX, W5HI, and W6VCJ. He also comments on the strength of the commercial stations W2XAD and W8XX on 19 metres, CT1AA and W1XAZ, all R8. VK3LR has also been logged between 8.15 and 8.30 G.M.T. at R7-8.

From the listening post at Standon, R. D. Everard says that he is losing a lot of DX stations owing to high noise level on his big receiver, so he is going to build the Contest Three. I have the same trouble, particularly on the top

bands, and I find that this receiver is very often more useful if headphones are used than my large super. The star DX stations heard at Standon this month were XIT and XIK, TI2AP, all on 40 metres. On 20 metres our old friends K4SA, W3EHY, W3DDO, W4BFH, SP1ES and OE6DK.

### Transmissions from Iceland

Last month I queried reception of stations from Iceland. Mr. Everard tells me that on several occasions he has heard an Icelandic station calling the Faroe Isles. If anybody can confirm or deny this, I shall appreciate the information.

B.R.S. 1,287, G. Sadler, of Stamford Hill, has sent me a photograph of his receiving station. I certainly like his slow-motion dials; he should be able to calibrate his set quite nicely with these. B.R.S. 1,287 has received verification from W1OXDA who, by the way, is no more. On an o-V-1 receiver stations were heard from the following countries. VE, FB, YM, PK, FP, LA, U. OH, W6, OZ, HA, SP, OE and F. Good going for a two-valve receiver!

J. Fismond, of the Bennett Television Co., has been using a short-wave converter in conjunction with a three-valve A.C.-D.C. receiver, and with this hook-up and a 20-foot aerial, he has logged VK2ME and W2XAF at full loud-speaker strength. He has sent me a full list of items broadcast; during two hours the transmission was 100 per cent. word perfect. The whole of the transmission from PRV, Brazil, and several other stations were obtained without any aerial whatsoever. The actual pick-up being obtained from a lead-in wire a yard away from the receiver.

Stanley C Isaacs forgot to give me his address, which is a pity because he has a very fine report. He is also using an o-V-1 and has heard EA, PI, CT, ED, LX and PI stations in addition to the Japanese JVM on 27.9 metres. He finds 20 metres very productive for American and Canadian stations right up to 23.30.

Of the G stations I find the Scottish to be amongst the best. C5NW, Dundee, G6SR, Edinburgh, and G6UU, Bonyrigg, are R8-9 signals every evening from 23.30. I have worked these stations for the last week or so every evening and very rarely are they interfered with by QRM or suffer from fading.

I should like reports on G6GO, of Ashby Parva, who is putting out a very strong signal which is received all over the country. I can rarely give him a better report than R4-5, so I should like to know if any other readers find that this station can only be received in certain areas.

It does seem that on the 1.7 mega-

cycle band stations have unusual skip distances. For instance, at Lettsworth the best stations are those from Bristol, Birmingham, Cheshire, Scotland and Cornwall. Stations in intermediate areas are generally unreliable with poor signal strength. I should appreciate other readers' comments on these points.

For some time I have been using an eleven-valve S.S. super for all wavelengths. But just recently, owing to very bad noise level I went over to a tuned o-V-1. This was quite satisfactory with the exception of rather bad break-through from medium-wave broadcasters. I have just completed a two H.F. detector-Pen. receiver with ganged tuning and band-spreading for both the 160- and 80-metre bands. From the first preliminary tests it seems that this receiver will give me optimum signal strength with minimum noise level.

Talking about receivers, one of our most enthusiastic listeners, F. Baker, of Coulsden, has sent me the circuit of his set. It consists of a leaky-grid detector, transformer-coupled to a triode amplifier, which is in turn resistance-coupled to a pentode output valve. Both the low-frequency arrangement and the reaction circuit are unusual, but have proved to be very satisfactory. I have found from time to time that when a receiver has two low-frequency stages, one resistance coupled, it is always better to put the resistance coupling last, as it gives much smoother reaction.

A trip to Brussels has been arranged by G5UK and I strongly advise readers to take advantage of the facilities afforded. The tour commences on Friday, August 2, returning on Tuesday morning, August 6. The cost is £3 12s. 6d., subject to exchange fluctuation, and includes third-class British rail, second-class steamer, and second-class Belgian rail, together with "pension" in Brussels. The August Bank Holiday week-end has been chosen, for it coincides with the convention organised by the Reseau Belge. Early reservation is imperative and letters should be addressed to G5UK, Max Buckwell, 19 Meadway, Leigh-on-Sea.

Leslie Cooper, G5LC, has sent me some details of his latest transmitter. It consists of C.O. neutralised sub-amplifier and locked T.P.T.G., for 20 or 40 metres using a 7168 kc. crystal. A simple transmitter consisting of a pentode C.O. of about single P.A. is used on 80 and 160 metres, the crystal frequency being 1773 kc. 52 countries have been worked, and the station is licensed for all amateur bands.

WAC and B.E. certificates have been obtained.

G6AU is a comparatively new station and uses C.O. P.A. of conventional design with a PM24A oscillator and P4100 class-C amplifier. Choke control modulation is employed, the modulator being a Do24 running at 25 watts.

# Trade Notes of the Month

## Reports on Apparatus Tested

### "Reliance" Fixed Resistances

THE variable resistances and potentiometers of the Reliance Mfg. Co. have been used for some time by constructors in cathode-ray television equipment, and they will be interested to learn that this firm have now produced a range of small fixed resistances from 0.5 ohm to 500 ohms.

These are wound with stout-gauge wire on paxolin formers measuring  $2\frac{1}{2}$  ins. long by  $\frac{1}{2}$  in. wide, the connections being made to soldering tags riveted at the ends of the former. The end of the resistance wire is firmly squashed under the rivet and there is no possibility of a loose contact developing.

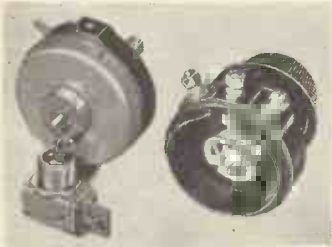

Two Reliance potentiometers.

The resistances are rated at 2-3 watts dissipation, but owing to the generous radiating surface provided it is probable that a higher current could be taken for short periods without damage. For self-bias circuits in output valves these resistances should be most useful and will occupy little room on the baseboard. The sample tested was of the low-resistance type (0.5 ohm) and is particularly intended for use in the cathode circuit of cathode-ray tubes when operating from a 2-volt cell or similar supply. Variable resistances of the same value can be obtained for fine control of filament current, and the photograph shows the construction of a variable type. The Reliance Co. also advise us that the high-resistance potentiometers for use in cathode-ray tube scanning circuits are now supplied with insulated spindles tested to 2,000 volts, which will avoid the risk of shock in high voltage time-bases.

The price of the fixed resistances described above is 1s. and they can be obtained from the Reliance Manufacturing Co., Westbury Works, Westbury Road, Walthamstow, or

### A Neat Synchronising Gear

MOST amateurs who build disc receivers sooner or later appreciate that a means of holding the picture steady without the necessity for hand-control is very desirable. No method of synchronising may be said to be perfect, but if suitable gear is used it is possible to hold the picture for periods of ten to fifteen minutes, and as a rule about three adjustments only are necessary during the course of a programme.

A neat and efficient synchronising gear has been produced by H. E. Sanders & Co., of 4 Grays Inn Road, W.C.1, which is shown by the photograph. A light skeleton cast iron phonic wheel is used and adjustment is provided both for height and pole-



The Sanders synchronising gear is adaptable for every type of mechanical scanner.

piece positioning; thus the gear is adaptable to any type of disc receiver. The light construction of the phonic wheel, which is of a specially soft grade of cast iron, precludes inefficiency due to eddy currents and makes possible a reliable instrument

at the low price of 25s. 6d. The phonic wheel can be obtained separately at 4s. 6d.

### A New Wearite Wave-trap Coil

ONE of the most popular receivers of the moment is the 1-V-1 with an untuned high-frequency stage. This type of set is ideal on all wavebands except the 160-metre amateur band where trouble is noticed from harmonics of the local medium-wave stations.

In some quarters this interference is so bad that the amateur stations cannot be received except after broadcasting hours. To overcome this trouble we have been using a Wearite iron-cored wave-trap coil designed for medium-wave receivers.

We found that this coil could be con-

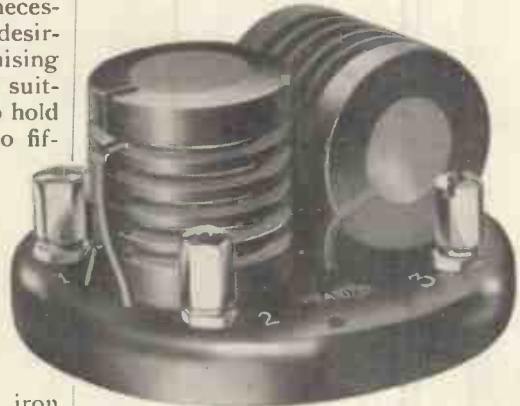

The Wearite wave-trap coil.

nected in series with the aerial lead-in wire and when tuned to the fundamental frequency of the interfering station the trouble was eliminated.

A typical example G6KV is in some areas blotted out by a harmonic of the London regional station. With the Wearite coil in the aerial and tuned to the wavelength of London the interference was cut out and G6KV heard free of whistles.

Only half of the coil need be used, for as a general rule the long-wave stations do not cause trouble. The lead-in wire from the receiver is removed and connected to terminal No. 1 on the coil. Terminal No. 2 is then connected to the aerial terminal on the receiver. Across these two terminals a .0005 variable condenser is connected for tuning. The price is 7s. 6d., and it can be obtained from Messrs. Wright & Weaire, Ltd., Tottenham.

### Clix Airsprung Valve Holders

ANTI-MICROPHONE valve holders do not always do just what they should. During the past few years we have tested several so-called anti-microphonic valve holders which were worse than the rigid type.



Some makers seem to think that the main feature with a valve holder of the spring type is for it to be wobbly. It has been proved that unless the valve used has a hooked filament this wobbling will tend to accentuate the microphonicity.

One of the most effective holders we

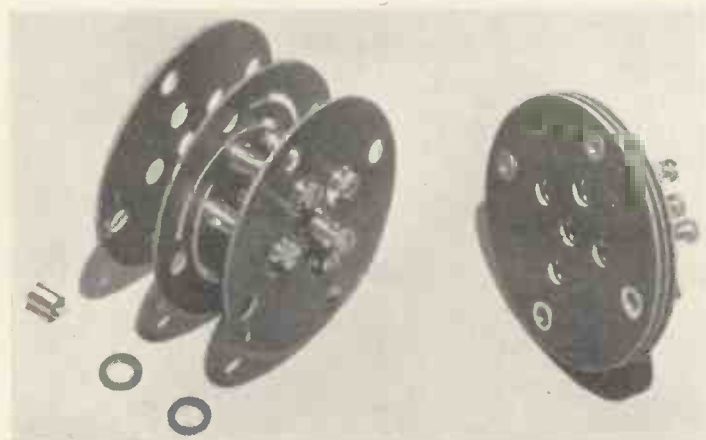

Two examples of the Clix Airspring valve holders.

have used is the Clix Airspring, which is made up of several distinct parts. The main body of the holder consists of the circular paxolin rings with the valve pins fixed to the middle one.

The middle ring is also cut to allow of free movement without letting the pins move too freely. These are so damped that the valve is only allowed to vibrate enough to stop any prolonged movement of the filament.

Clix "Airsprung" chassis mounting



The Amplion tubular fuse.

valveholders, are now available in 4-, 5- and 7-pin types, with or without terminal connections. The prices are: terminal type, 4-pin 1s. 2d., 5-pin 1s. 3d., 7-pin 1s. 4d. Without terminals: 4-pin 11d., 5-pin 1s., and 7-pin 1s. 1d.

The manufacturers are Lectro Linx, Ltd., 79a Rochester Row, London, S.W.1.

### Fuses for All Purposes

**T**UBULAR fuses are almost invariably used in commercial receivers, but the amateur constructor still seems to favour the bulb type of fuse. Valve manufacturers receive a large number of letters from customers who have burnt out a set of valves without blowing the safety fuse.

The Amplion Co. have just brought out a complete range of tubular fuses of standard dimensions, so they are interchangeable with fuses of all types. The actual length is  $1\frac{1}{4}$  ins. for all fuses between 60 milliamperes and 3 amperes.

We find these fuses very useful indeed. It is only a matter of a moment to fit a new fuse or to change the value of the fuses already in the set. The Amplion fuses are very accurate, that is to say, they really do fuse at the current indicated. They are available in the following values and all are

priced at 6d., 60, 100, 150, 250, 500, 750, 1,000 milliamperes, and 1.5 A, 2 A and 3 A. The makers of these fuses are Amplion (1932), Ltd., 82-84 Rosoman Street, Rosebery Avenue, E.C.1.

### High-quality Short-wave Components

**B**IRMINGHAM Radiomart have all those components the keen short-wave fan requires. Variable condensers that are perfectly noiseless in operation, slow-motion dials free from all backlash, and high-quality coil formers.

One of the most interesting of the components we have tried is the two-gang split-stator brass-vaned tuning condenser mounted on a steatite base. It is ideal for use in the high-frequency and detector stages of a receiver as even when the receiver is in oscillation no rustle can be detected when the condenser is varied. Transmitting fans will realise that these condensers are suit-

able for use in low-power transmitting circuits. If used for tuning the tank coil a much more stable signal can be

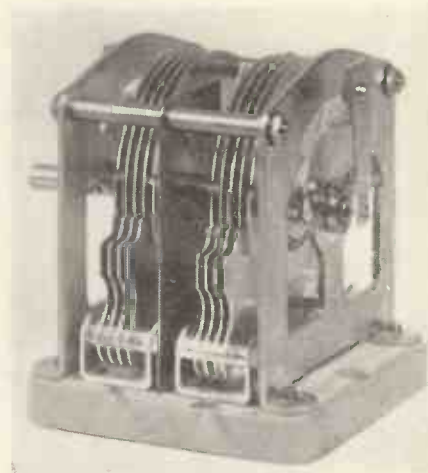

The Radiomart two-gang split stator variable condenser.

obtained when the rotor is connected to earth. Another use is to tune the grid circuit of a push-pull P.A. The capacity of this condenser is .00016 mfd. each half, and the price 5s. 6d.

The coil formers will fit a standard 7-pin base and are made of the highest quality bakelite. Being of standard dimensions all standard windings will be suitable.

We found that a set of these coils wound one for each amateur band gave fine results in a band-spread receiver. The prices of these coil formers are: 4-pin, 1s. 6d.; 6-pin for 7-pin valve holders, 1s. 9d. The diameter of both types of coil is  $1\frac{1}{2}$  ins.

In addition to these components there are stand-off insulators in three sizes, milliamperemeters covering all ranges priced at 5s. 9d., and Western Electric microphones for 2s. 9d.

The suppliers of these components are The Birmingham Radiomart, 19 John Bright Street, Birmingham.

Read  
"Television  
and  
Short-wave  
World"  
Regularly

**1935 EDITION... FREE!**

A New and greatly enlarged edition of "ENGINEERING OPPORTUNITIES" is just off the Press. It describes the easy way in which you may become an A.M.I.C.E., A.M.I.Mech.E., A.M.I.E.E., A.M.I.A.E., A.M.I.W.T., etc.

**Under our "NO PASS—NO FEE" Guarantee** and contains the world's widest selection of courses in all branches of Civil, Mech., Elec., Motor, Aero., and Radio Engineering, Television, Building, etc.

If you are earning less than £10 a week, you cannot afford to miss this unique guide to a first-class job. **DON'T DELAY**—send for FREE copy of the Handbook to-day. No cost or obligation of any kind.

**THE BRITISH INSTITUTE OF ENGINEERING TECHNOLOGY**, 337, Shakespeare House, 29/31, Oxford Street LONDON.

Sth. African Enquiries: P.O. Box 4701, Jo'burg.  
Australasian Enquiries: P.O. Box 3597S, Sydney.  
Canadian Enquiries: 219, Bay Street, Toronto.





MAY, 1935

**"A Test Transmitter for 7 Metres"**

(Continued from page 273.)

is impossible to modulate more than 20 or 30 per cent., and, since television requires modulations up to practically 100 per cent. quite frequently, this again is a limitation which cannot be tolerated.

In the circumstances a direct modulation system has been used. The H.T. supply to the oscillating valve is obtained through a second (similar) valve of which the grid bias is controlled by the modulation. When the grid approaches zero the resistance of the valve is small and the maximum voltage is applied through the oscillator valve. As the bias on the modulator valve is made more negative the resistance of the valve increases and consequently the voltage across the oscillator valve falls.

**LIST OF PARTS**

**TRANSMITTER.**

- One Eddystone .00015-mfd. condenser with extension handle.
- One Eddystone steatite valveholder (4 pin).
- One ordinary 4-pin valveholder.
- One 30-ohm humdinger.
- One .01 mfd. mica condenser.
- One .0005 mfd. mica condenser.
- One 1,000-ohm resistor.
- One S.W. choke
- Two O 15/400 valves.
- Terminal panel with 6 terminals.
- Terminal panel with 2 terminals.
- Baseboard, 14 s.w.g. wire, etc.

**POWER UNIT.**

- One transformer—750-0-750, 50mA 4V., 1A.; 4V., 1A. C.T.; 7.5V., 2.5A. (B.T.S.)
- One Bulgin choke.
- One 2-mfd. condenser 1,000V wkg. T.C.C. jelly-filled.
- One 4-mfd. condenser 1,000V wkg. T.C.C. elly-filled.
- Two American type 4-pin valveholders.
- Two VX 2810 valves.
- One 100,000-ohm 3-watt resistor.
- Baseboard, terminal panel and 6 terminals

The overall high-tension voltage, of course, has to be increased, and in fact with two similar valves for oscillator and modulator twice the normal H.T. is necessary. In the first instance, therefore, 800 volts

H.T. is supplied and with zero bias on the modulator valve each valve takes 400 volts. As the bias on the modulator is run back, less and less voltage is available for the oscillator and the oscillating current runs down.

Fig. 6 shows the modulation characteristic of the arrangement which will be seen to be linear over 80 per cent. of the range, after which it does admittedly begin to fall off; but this is a much better characteristic than can be obtained with a choke modulator unless quite a considerable power is used in the modulator stage. The fact that this curve could be taken at all shows that the current will modulate right down to zero frequency.

The second and equally important advantage is that as there are no coupling impedances the modulation is effective right down to zero cycles (D.C.) so there is no bass cut-off while the high-frequency response only begins to fall off when the valve capacity becomes comparable with the resistance of the valve. Since the valve resistance is about 1,600 ohms, and its self- and stray-capacities are probably not more than 50 micro-microfarads, we are able to modulate at frequencies well over a megacycle.

**Power Unit**

The power unit has been built separately and is quite straightforward in character. For simplicity ordinary hard rectifying valves are employed with the customary smoothing circuit. The only point of interest is that two 4-volt windings have to be employed, and they

**A General Purpose SHORT-WAVE WAVE METER**

RANGE—9.5-220 METRES

All amateurs will realise the large number of uses to which a wave meter of this type can be put. It is buzzer excited and can be used as a signal generator which will not vary. The circuit design also enables it to be used as an absorption meter with the same calibrations holding good. The meter is built in a diecast metal box of handy size and rigid construction. The wave-range is covered with three coils, a calibrated chart being supplied for each. The buzzer is rubber mounted and though mechanically hardly audible, it gives a clear high pitched note without splutter and is very sharply tuned.



PRICE £3 : 3 : 0 Complete

**PRICE LIST of EDDYSTONE COMPONENTS for the ALL WAVE SUPER**

	s.	d.
1—15 m.mfd. Microdenser No. 900	...	3 9
1—.0002 S.M. Condenser No. 957	...	6 0
1—2 mfd. Condensers No. 990	...	4 0
2—Screened H.F.C. No. 982	... each	5 0
1—Slow Motion Dial Drives No. 970W.	...	10 6
3—I.F. Units 450 Kc/s No. 674	... each	10 6

**STRATTON & CO., LTD.**  
Bromsgrove Street, BIRMINGHAM.

London Service Depo.:  
WEBB'S RADIO STORES,  
14, Soho Street, Oxford Street, W.1.



**EDDYSTONE**

**HIGH GRADE COMPONENTS**

It helps us if you mention "Television and Short wave World."

**"A Test Transmitter for 7 Metres"**

(Continued from preceding page.)

must, of course, both withstand 400 volts between each other and 800 volts to earth.

Two single-wave rectifiers, type VX2810 have been used because they were the only normally-listed valves suitable for 750 volts H.T. They are capable of delivering 100 milliamps. so that they are working well within their capacity. To minimise voltage fluctuations a small load of 100,000 ohms has been connected permanently across the supply. This has the further advantage of discharging the condensers when the transmitter is switched off. Otherwise if the oscillator valves cool before the rectifiers there is a danger of some voltage being left on the condensers.

The new T.C.C. jelly-impregnated condensers have been used, which enables a quite compact power unit to be built up despite the high voltage. Incidentally it is as well to fit a metal cover over the whole unit or arrange some alternative protection against accidental contact with the live terminals. Still better modulating characteristics can be obtained with slightly smaller power output by omitting the first condenser of the filter, as described in my article last month. The H.T. voltage is then only some 600 volts, as against 750 to 800, but the regulation is better and the circuit will modulate with a smaller input. Generally speaking, however, the arrangement given will be satisfactory for, as will be seen from Fig. 6, full modulation is obtained with about 40 volts peak.

**Operation of Transmitter**

A grid-bias battery has been used to supply the modulator valve for convenience. It could be dispensed with by using a self-bias arrangement consisting of 1,000 ohms by-passed by a large condenser (at least 50 microfarads) connected between the centre tap of the 4-volt winding for the modulator valve and H.T.—, but such an arrangement is bound to introduce some frequency distortion, and for the greatest fidelity the battery is preferable.

The modulation itself is introduced in series with the battery and should be adjusted to be about 40 volts peak, the battery itself being 36 volts. With no modulation on the anode, current should be between 40 and 50 milliamps., varying slightly according to the load on the transmitter.

Adjustment of the filament tap should be made on the aerial-current ammeter. Having adjusted the oscillating circuit to the required wavelength the aerial should be tuned-in until maximum current is obtained. The position of the filament tap should then be adjusted until this current is a maximum. This must *not* be done while the transmitter is switched on, unless rubber gloves are worn, as the filament of the oscillator valve is 400 volts above earth.

When the modulation is switched on this current will increase to an extent depending on the depth of modulation and the type of signal. It should, however, never increase more than 20 per cent. With a pure sine-wave modulation the increase in oscillating current for 100 per cent. modulation is 23 per cent. With a television or even a radio signal, where the wave-form is very peaky, full modulation may be reached on the peaks while the average depth of modulation is much less.

**TAKE THE DESIGNER'S TIP!**

ERIE Resistors and Volume Control SPECIFIED FOR The "ALL WAVE SUPER" Receiver and Amplifier.

**Insist on ERIE RESISTORS**

It's not by chance that designer and manufacturers alike use Eries. It's because they are the best for the job. An important factor is their consistency and inherent stability. Insist on Eries. See that the Resistors you buy bear the genuine Erie identifying label.



1/- Per Watt in all Values. Each resistor colour-coded, labelled and Guaranteed.

FREE. Send for the invaluable Erie Resistor Guide—"Erie Service Instruction Booklet."

**Insist on the ERIE Volume Control**



3/6 or with built-in mains switch 5/-

Whatever your set, fit the Erie Variable Resistance. With the bonehard Erie resistance element and Erie precision construction, it is a definite improvement on everything else of its kind. Contact is smooth and positive; there are no hop-off noises; its absolutely noiseless efficiency is permanent. Made in all values. 5,000 ohms to 2 megohms. At all dealers.

**THE RADIO RESISTOR CO. LIMITED**  
1, Golden Square, Piccadilly Circus, London, W1



**B.T.S. 1935 SHORT WAVE ADAPTOR**

Make your Set an All-Wave Set . . . receive America direct. No alterations whatsoever. . . simply plugs into your present Battery or A.C. Mains Set. With 2 plug-in coils, 13-52 metres. Send only 7/6; balance in 10 monthly payments of 5/-. Cash or C.O.D. Carriage Paid, £2/12/6. Extra Coils, 46-96 and 90-190 meters, 4/6 each.



**7/6 DOWN**

Send for descriptive leaflet.

**New DISCOVERER H.F.P.3**

**Gauranteed WORLD WIDE SHORT WAVE RECEPTION**

COVERS 13-96 METRES 12,000 MILES TUNING RANGE

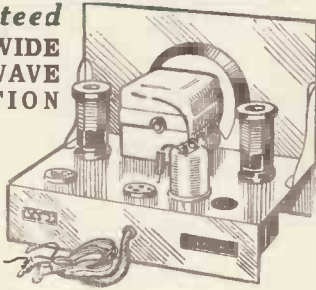

**KIT "A"** Comprises all necessary parts to build, with 6 coils (13-96 metres), less valves and cabinet. With Full Size Blueprint and detailed instructions. Cash or C.O.D. Carriage Paid, £4/15/0, or 7/6 deposit and 11 monthly payments of 9/- **FINISHED INSTRUMENT.** Cash or C.O.D. Carriage Paid £8/0/0, or 12-monthly payments of 15/-

**7/6 DOWN**

Send Coupon for details and FREE BLUEPRINT.

**PILOT AUTHOR KIT EXACT TO SPECIFICATION**

Build with a Pilot Author Kit and make a 100% success certain. Since 1919 the most popular Kits with Home Constructors the whole world over because they are exact to the designer's specification and are complete down to the last screw and piece of wire.

**ALL WAVE SUPER**

Described in this month's issue

**RECEIVER KIT.**—Author's Kit of First Specified parts for Receiver Portion only, less Cabinets, Valves and Speaker. Cash or C.O.D., Carriage Paid, £8 0 0 Or 12 monthly payments of 14/9

**AMPLIFIER KIT.**—Author's Kit of First Specified Parts for Amplifier Portion only, less valves, cabinets and speaker. Cash or C.O.D., Carriage Paid £7 6 0 Or 12 monthly payments of 13/3

**COMPLETE KIT.**—Author's Kit of First Specified Parts for Receiver and Amplifier Portions, including set of 6 Specified Valves and Peto-Scott Twin de Luxe Cabinets, less speaker. Cash or C.O.D., Carriage Paid ... £22 8 0 Or deposit £3/18/6 and 11 monthly payments of 37/-

**KIT-BITS** You pay the Postman. We pay post charges on all orders over 10/- G.T. BRITAIN ONLY.

<b>RECEIVER.</b>	£ s. d.
1 Peto-Scott Ready-drilled Zinc-covered Chassis	2 9
4 Specified Valves	3 6 0
<b>AMPLIFIER.</b>	
1 Peto-Scott Ready-drilled Zinc-covered Chassis	1 9
2 Specified Valves	1 11 0
Peto-Scott Twin De Luxe Cabinets...	2 5 0
(Receiver Portion, £12/6. Speaker and Amplifier Portion £11/5/0.)	
1 W.B. Stentorian Senior Speaker.	2 2 0

**BEGINNERS' SHORT WAVE 2**

**KIT "A"** CASH or C.O.D. £2 : 13 : 6 Carriage Paid. Author's Kit of first specified parts, including ready-drilled Aluminium Baseplate and Panel, with Bulgin Short Wave Coils, less Valves, and 8 monthly payments of 6/6

**CONTEST THREE**

**KIT "A"** Cash or C.O.D. £5 : 13 : 6 Carriage Paid. Or 12 monthly payments of 10/6. **KIT "A"** Author's Kit of First Specified parts less Valves and Cabinet. Set of three Specified Valves ... £1 12 6 One Peto-Scott Cabinet ... £1 0 0

**FREE BLUEPRINT OFFER**

PETO-SCOTT CO., LTD., 77 (Dept. T.4), City Road, London, E.C.1. Telephone: Clerkenwell 9406-7. West End Showrooms: 62 (Dept. T.4), High Holborn, London, W.C.1. Telephone: Holborn 3248. Please send me descriptive literature of the Peto-Scott **NEW DISCOVERER H.F.P.3**, together with **FREE BLUEPRINT**, for which I enclose 1½d. in stamps to cover postage.

NAME .....  
ADDRESS .....

SEND FOR LATEST TELEVISION LISTS.

Quick fault-tracing

DEMANDS

**ACCURATE TESTING**



Even the smallest degree of distortion in television calls for immediate remedy. Slight faults which might pass unnoticed in radio become, in television, glaringly apparent imperfections. More than ever is an accurate testing meter of first importance—vital to perfect reception.

The world-famous D.C.

**AVOMINOR**

Regd. Trade Mark

Is 10 accurate instruments in one. Circuits, valves, components, batteries and power units can all be tested quickly and easily. In handsome case, with leads, interchangeable crocodile clips, testing prods and instruction booklet.

**The UNIVERSAL AVOMINOR**

Gives 22 different ranges of readings. The best of A.C. and D.C. meters. 3-inch scale. Total resistance 200,000 ohms. Complete with leads, crocodile clips, testing prods and instruction booklet

**THE AUTOMATIC COIL WINDER AND ELECTRICAL EQUIPMENT CO., LTD.**

Winder House, Douglas Street, London, S.W.1. Telephone: Victoria 3404-7.

- CURRENT**
- 0-6 milliamps
- 0-30 "
- 0-120 "
- VOLTAGE**
- 0-6 volts
- 0-120 "
- 0-300 "
- RESISTANCE**
- 0-10,000 ohms
- 0-60,000 "
- 0-1,200,000 "
- 0-3 megohms

The D.C. AVOMINOR

**40/-**

Deferred Terms if desired.

**The UNIVERSAL AVOMINOR**

- D.C. VOLTS**
- 0-75 millivolts
- 0-5 volts
- 0-25 "
- 0-100 "
- 0-250 "
- 0-500 "
- MILLIAMPS**
- 0-2.5 milliamps
- 0-5 "
- 0-25 "
- 0-100 "
- 0-500 "
- A.C. VOLTS**
- 0-5 volts
- 0-25 "
- 0-100 "
- 0-250 "
- 0-500 "
- RESISTANCE**
- 0-20,000 ohms
- 0-100,000 "
- 0-500,000 "
- 0-2 megohms
- 0-5 "
- 0-10 "



**£5**

Deferred Terms if desired.

Send for fully descriptive folders, post free.



Commercial Receivers for the Short-waves : No. 4.

# The Philco All-wave Super-het

**D**URING the past year we have been trying to find a receiver of extreme sensitivity and selectivity on all wavebands. We have found it, a set that will bring in short-wave stations from 12 to 200 metres, and medium wavers from 200 to 560 metres.

## An Eleven-valver

The receiver to which we refer is the Philco 16B all-wave super using eleven valves. It will cover all the wavebands mentioned in five distinct steps. A separate tuning dial is brought into view for each of the five channels. These wavebands are all calibrated in frequencies and so accurately that we could often check up wavelengths of new stations heard.

This Philco set is ideal for amateur transmitting or receiving stations. The ordinary man in the street who wants to hear all the programmes there are will also find this set ideal, and in addition short-wave stations from all over the world can be heard with great reliability and good volume.

We have been using this receiver for

some time now to log amateur stations on all bands. The ordinary commercial short-wave stations can also be received from midday until the early hours of the morning.

We can say with every confidence that a minimum of 20 short-wave stations can be heard at any time of the day. By referring to our log book for the past few months we noticed such entries: ninety-five 20-metre phone stations, mostly from America, in less than two hours; Sydney at full loud speaker strength for a period of nearly two hours; 160-metre amateur stations on the loud speaker from distances up to 500 miles, and so on.

On all wavebands the receiver is extremely efficient, not like some sets that have good and bad patches. Tuning is by means of a single dial which can be pulled in or out to give slow or fast gearing as required.

Switching for all wavelengths down to 12 metres is accomplished by means of a single switch, while the master volume control is combined with the on-off switch.

Most of our readers have the impression that a short-wave receiver must

have lots of controls and be tricky to handle. Nothing is farther from the truth with the Philco 16B. The controls are more simple than with the average medium-wave set.

The length of aerial used is immaterial; if it is too long, instead of causing the receiver to stop oscillating on the shorter wavebands, nothing happens at all to the reception, except some times an increase in volume.

As a typical example of what we mean, a station in Boston, Mass., was being heard on the loud speaker with a 50-foot elevated aerial. When the receiver was connected to an un-insulated stay wire that was holding up the aerial mast there was not any appreciable decrease in signal strength. The A.V.C. action was sufficient to keep the signal strength up to the original level.

Compactness is another feature. The receiver is no larger than the average five-valve super.

On the medium waveband the most impressive feature is the genuine 9 kilocycle separation. Every European station that has a 9 kilocycle separation from its neighbour can be received without trouble.

Quality is good, while a four-position tone corrector switch enables the switch to be varied at will. The output is up to 10 watts and this output can readily be obtained from distant stations and from the short-wave Americans.

Every part of the circuit is completely screened. The amateur transmitter will find that duplex working is now possible on much closer frequencies to transmitter frequency than with ordinary super-hets, while pick-up from local stations or nearby interference is greatly decreased.

We cannot speak too highly of the receiver no matter from what angle it is considered. It appears to be ideal for all types of listeners.

## Technical Data

Model: 16B.

Price: £36 5s.

Valve combination: Oscillator (Philco 76), first detector (Philco 77), two intermediate-frequency stages (Philco 78), diode detector (Philco 37), first low-frequency amplifier (Philco 77), driver (Philco 42), class A output (two Philco 42's), Q.A.V.C. control valve (Philco 78), and a full-wave rectifier (Philco 80).

Mains supply: A.C. only, 200-250 volts.

Type: 11-valve all-wave super-het.

Makers: Philco Radio and Television Corporation, Ltd.

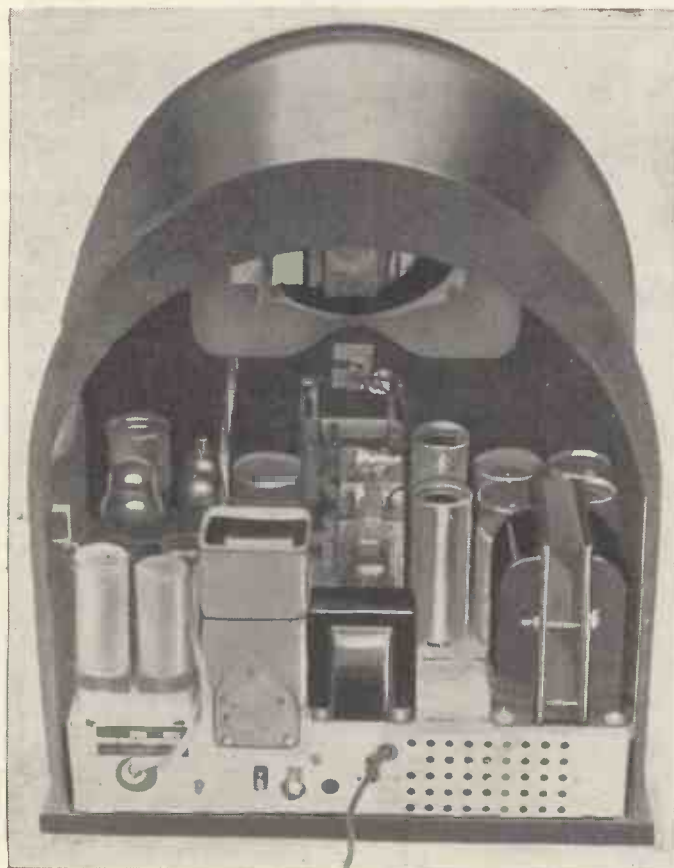

*This all-wave receiver although it uses eleven valves is no larger than the average broadcast super-het. Ganged tuning, single dial control and A.V.C. on all wavelengths are only three of the many features of this receiver. Five tuning scales, all calibrated in frequencies, is a fine idea for it overcomes the difficulty of designing a clear tuning scale.*

**TELEVISION IS YOUR OPPORTUNITY!**

**IMPORTANT  
NEW PART WORK  
PARTS 1 and 2 OUT NOW**

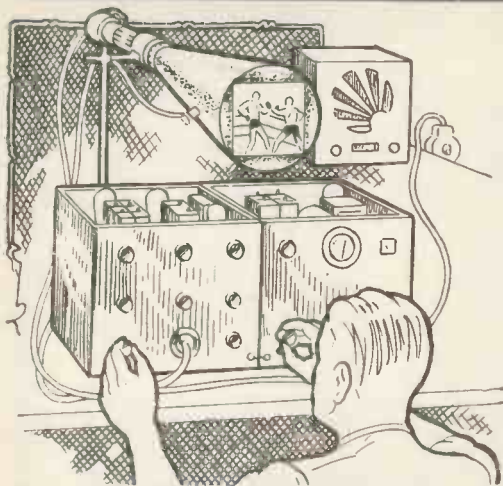

**COMPREHENSIVE  
AUTHORITATIVE  
PRACTICAL**

THE contributors to "TELEVISION TO-DAY" include many distinguished names. As an example may be mentioned Dr. V. K. Zworykin, the inventor of the Iconoscope; and Philo Farnsworth, the inventor of the Farnsworth Camera and the Electron Multiplier. Engineers connected with some of the chief companies concerned with the commercial development of Television have written important sections of the work.

How many of these experts do you know? They all contribute to "TELEVISION TODAY."

- |                       |                        |
|-----------------------|------------------------|
| Philo Farnsworth.     | V. K. Zworykin.        |
| Capt. A. G. D. West,  | L. H. Bedford, M.A.    |
| M.A., B.Sc.           | R. W. Corkling,        |
| F. J. Camm.           | M.I.R.E.               |
| H. J. Barton Chapple, | Dr. Alfred Gradenwitz. |
| B.Sc., A.M.I.E.E.     | E. W. Hobbs, A.I.N.A.  |
| J. J. Denton, F.T.S.  | Percy Harris, M.I.R.E. |
| F. H. Haynes.         | R. J. Kemp.            |
| T. D. Humphreys.      | T. M. C. Lance,        |
| E. Bolton King, M.A.  | A.M.I.R.E.             |
| N. Levin.             | L. M. Myers, F.T.S.    |
| N. W. Maybank.        | O. S. Puckle.          |
| W. J. Nobbs, F.T.S.,  | C. Quarrington.        |
| A.M.I.R.E.            | E. H. Traub, F.T.S.    |
| G. Parr, F.T.S.       | W. D. Wright, D.Sc.    |
| A. T. Sinclair.       | R. C. Walker, B.Sc.,   |
| J. H. A. Whitehouse.  | A.M.I.E.E., A.M.I.     |
| H. W. W. Walden.      | Mech.E.                |

Get Parts 1 and 2 "TELEVISION TO-DAY" from your Newsagent, 1/- each or direct for 1/2 each post free from George Newnes, Ltd., 8-11, Southampton Street, Strand, London, W.C.2.

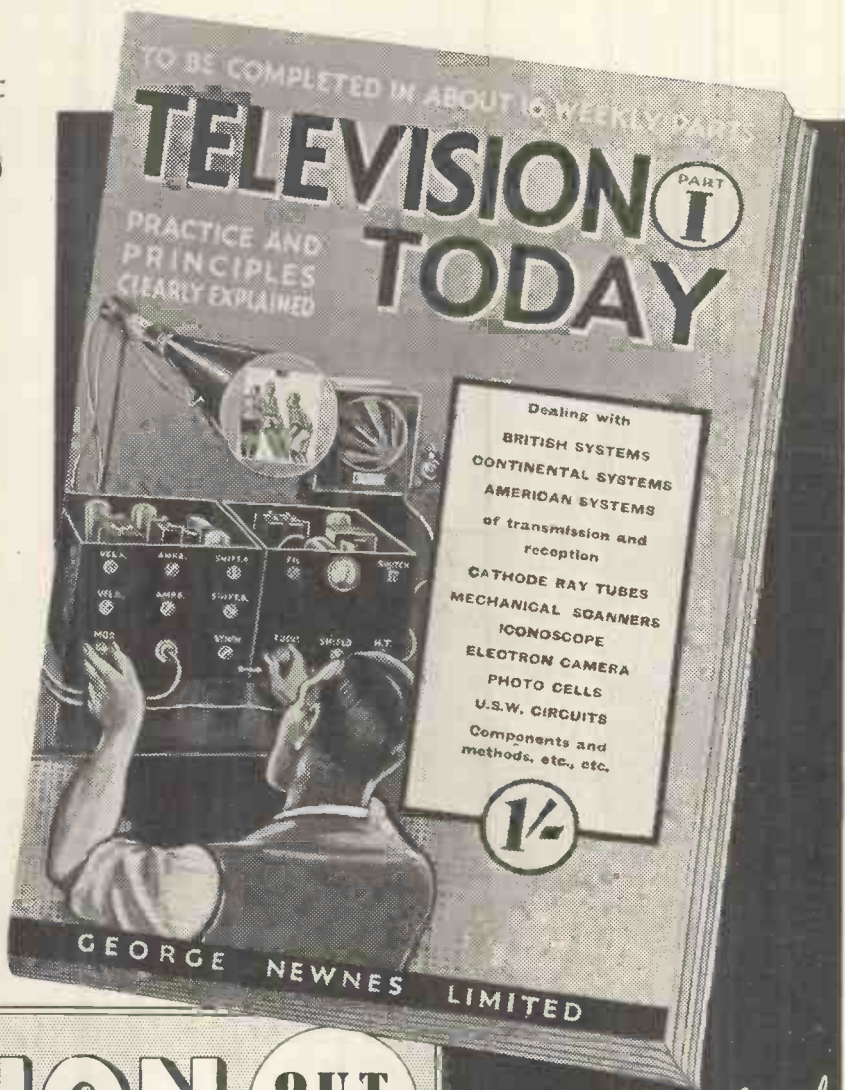

**TELEVISION**

**OUT  
NOW**

**PRACTICE  
AND PRINCIPLES  
CLEARLY EXPLAINED**

**TODAY 1/2**

*To be completed  
in about 16  
Weekly Parts*





# Correspondence

Correspondence is invited. The Editor does not necessarily agree with views expressed by readers which are published on this page.

**Television for the Provinces :: Amateur Transmitters :: An American Opinion :: Amateur Television Transmissions Thirty-line Transmissions.**

## Television for the Provinces

SIR,

May I add my support to the question raised by your correspondent, Mr. E. K. M. Bird, in the April issue of TELEVISION AND SHORT-WAVE WORLD.

I have had for this last two years a viewer, home-made but good, that I use regularly. Owing to the very snobbish attitude of the "powers that be" I have to be content to see via the London station only, which is the world's worst for reliability in the north. If, as Mr. Bird suggests, the transmissions were sent out from Midland Regional, the whole country would benefit from the increased power, etc. Personally, I think it is about time the authorities realised that their "London first" policy is disheartening experimenters "up north." I am sure that regular transmissions from the Midland station would satisfy everybody, besides giving us up here a chance to solve some of the mysteries of television. I think you will find that the majority of northerners agree with me.

MANCHESTER.

\* \* \*

## Amateur Transmitters

SIR,

I should like to add my congratulations to the many you have already received in connection with your new publication. At last the short-wave enthusiast is being catered for by a British periodical. And now a word of warning—you have published a most admirable and lucid article on the construction of a short-wave transmitter. I suggest that you should make it abundantly clear to your readers, many of them no doubt young and having their first experiences in short-wave work, that transmitters cannot be built or worked without the necessary licence. It will soon be found by many young experimenters and perhaps new enthusiasts of more mature years that it is easier to construct a low-powered transmitter than many of the modern

broadcast receiving sets—having built one, the urge will be to operate it. The pirating of call signs held by amateur experimenters is unfortunately on the increase, and every effort should be made to stop this lamentable practice. I am sure that you as a periodical interested in the welfare and future of British experimenters will appreciate this point.

Our amateur transmitters have a reputation second to none in the world and we look to those who will join us in perhaps the most fascinating hobby of our time to uphold this prestige; this cannot be done if the newcomer to amateur radio illegally operates a transmitting station. Apart from the legal aspect of this matter such an act brings the whole of the amateur movement into disrepute.

Again congratulating you and wishing you every success.

G5ZG (Chigwell, Essex).

\* \* \*

## An American Opinion

SIR,

In a letter from the well-known American amateur transmitter, W2FLT, in New Jersey, he makes a few remarks on the quality of our new book. Perhaps you will allow me to quote his words for interest on this side:—

"I must say, that at last you have the makings of an amateur mag. Believe me, hats off and all credit to TELEVISION AND SHORT-WAVE WORLD! I believe it is a step towards the American way of publicity, and that it is one of the finest things that could happen to British amateur radio. However, it retains a wholesome amount of that British reserve which I admire so much. Long live TELEVISION AND SHORT-WAVE WORLD and may it keep going forward.

"Not only do I like the mag itself, but also its policies . . . A darn nice little mag. with plenty of meat and no bunk."

His remarks may seem a little out of place to those members of the R.S.G.B., but I may say that the

existence of the "Bull" is well-known to him, and as we all know, it cannot be bought at the bookstalls.

The contents exceed my earliest expectations especially in regard to individual articles, and I'm pleased also to see that the old features are not being squeezed out.

Each member of the Hampstead Radio Society MDP wishes me to say "thanks," and may your pages increase!

W. A. CLEMENSON  
(West Hampstead).

\* \* \*

## Amateur Television Transmissions

SIR,  
Would it interest your readers to know that the G.P.O. have agreed to my request to include television transmissions, on a closed aerial, with my transmitting licence?

My first transmitting licence was 6PQ for 10 watts, but when my Marconi operator left, the G.P.O. reduced my power and put me on the closed aerial circuit; but now that one of my tenants is an ex-Marconi operator and is drilling me well with morse, I hope to get full transmitting facilities restored. In the meanwhile, I can manage to test apparatus, and my call sign is 2BKC.

My proposition that free television licences be granted to the dumb and deaf, and a national fund be established to give those unfortunately afflicted people free television sets, has been referred to in *World Radio*; and I have had letters from the B.B.C. and the G.P.O. about the idea. But you have not yet mentioned it in your magazine.

FRED. W. EDWARDS, F.T.S.  
(Castle Gresley, Burton-on-Trent).

\* \* \*

## Thirty-line Transmissions

SIR,

I am in complete agreement with your correspondent, Mr. A. Graham, regarding his proposal to transfer the existing television equipment from London to Manchester, after the inauguration of the high-definition transmissions.

The North National station could be used for the transmission of vision, and Midland Regional for sound, as at present.

I fail to see why enthusiasts outside the London area should be deprived of television facilities, whilst, as is usually the case, Londoners enjoy the fruits of the latest developments.

HENRY MYERS (Bolton).

(Continued on page 302.)

# WEARITE

## COMPONENTS

SPECIFIED for the  
**ALL-WAVE SUPER**



The Wearite 1.22 Rotary Switch (D.P.D.T.)

A neat positive-action switch of finest materials. Low capacity. **3/6**

One of the "1" series of D.T. switches, with indicator window.

The Wearite L. F. CHOKE  
Type H.T. 35. . . . .

30 Henries. 50 m/a. **10/6**  
1600 ohms resist.

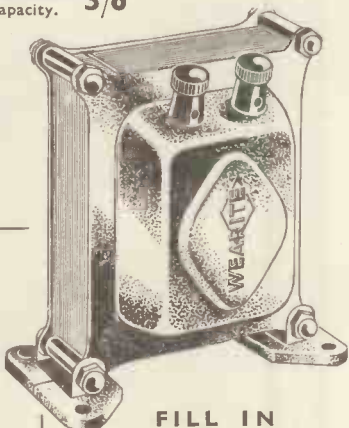

**FILL IN  
AND POST THIS  
COUPON TO-DAY!**

Name .....

Address .....

T.5/35. ....

To Messrs. Wright and Weare, Ltd.,  
740, High Road, Tottenham, N.17.

Please send copy of your Booklet A834 with technical data on Coils, Chokes, Transformers and Theoretical Circuit Diagrams. Please also send leaflet on NEW WAVE TRAP COILS.

6741



**SPECIFIED  
AGAIN!**

**THE J.B. SPECIAL  
POPULAR LOG FOR THE  
"AMATEUR BAND SUPER"**

00025 D.S. Price

**5/-**

This double spaced condenser has been specially designed by J.B. Technicians for the "Amateur Band Super" described in this issue of "Television." Its smooth action gives knife-edge tuning without effort. Write now for our free illustrated catalogue describing this and other J.B. components in full detail.

JACKSON BROS. (LONDON), LTD., 72, St. Thomas St., S.E. 1.  
Telephone: Hop. 1837.

## THE SIGN OF THE BLACK DIAMOND



The black diamond definitely identifies YOU as a radio amateur.

For nearly 22 years the R.S.G.B. badge has proved a silent witness to the value of co-operation in Research and Experiment. Let us tell you how you may become a member of this senior amateur radio organisation.

### MEMBERSHIP BRINGS—

A copy of the T. & R. Bulletin each month—free QSL service facilities—calibration service—slow morse practices—organised contests—field days—conventions—participation in the work of the Society's Research and Experimental section—

### A GUIDE TO AMATEUR RADIO (2nd Edition).

Explains in detail how to become a radio amateur, price 8d. post free.

All communications to :—

**THE SECRETARY** (Dept. S.W.4),  
Radio Society of Great Britain,  
53, Victoria Street, London, S.W.1.

## FOR YOUR TELEVISION SET

Use Varley Components for your television set. Remember that thirty-six years experience in specialised electrical engineering goes into the production of every Varley product.

Write for free catalogue.



E.P. 20 Mains Transformer 27/6

- Mains Transformers.
- Heavy Duty Smoothing and Output Chokes.
- High Inductive Chokes.
- Resistances. All Types.
- Power Potentiometers.
- Volume Controls.
- Nicore Flat-Gang Units.
- Duo-Nicore Coils.
- Junior H.F. Chokes.
- Nicore H.F. Chokes.

# Varley

PROPRIETORS:- OLIVER PELL CONTROL LTD

Oliver Pell Control Ltd., Bloomfield Road, Woolwich, S.E.18.

Tel.: Woolwich 2345

Mention of "Television and Short-wave World" will ensure prompt attention.



“Correspondence”

(Continued from page 300).

**A Mystery Transmission**

SIR,

In reference to Mr. R. F. Hansford's (Bognor Regis) letter, you may be interested to know that I received a mysterious television signal on a wavelength of 483.5 metres. On referring to a station chart I found 483.8 metres to be the wavelength of Brussels No. 1; by altering the dial a fraction I received this station quite clearly, and then moving the dial to the opposite side of the transmission I received Trondheim. The list of stations, however, gave no indication of a station between these two and I could not identify the station. The time was 6.30 G.M.T.

D. ATKINSON (Tynemouth).

SIR,

I also picked up this transmission on February 28 and believe that it came from Moscow No. 4 (RW39 Stallina) and can only assume that Mr. Hansford was using an old identification chart, for Bucharest and West Regional are both just above this Moscow station.

The pictures were very poor, but I

was almost as thrilled as when I saw my first images over two years ago.

With regard to the normal transmissions from London I find that those on Wednesday evenings are almost useless owing to fading and distortion which gives rise to two superimposed pictures being seen, the one about half a frame above the other. Sometimes the top picture predominates; sometimes the lower. I presume this is due to the difference in time taken by the ground and reflected rays to reach the set.

As a reader from No. 1 may I add my congratulations on your excellent magazine and wish it every success.

T. S. BERRY (Smethwick).

**Image Changing**

SIR,

Your correspondents, Jensen and Base (Wallasey), in their letter in the April issue of TELEVISION AND SHORT-WAVE WORLD, state that they have experienced the effect of an image changing from positive to negative without apparent cause.

I have experienced this several times during the last eighteen months, particularly on nights when fading and echo images were pronounced.

I did not attach much importance to it at the time, as I was using a cumulative grid rectifier, and thought it was being overloaded by a temporary rise in signal strength, thereby causing anode-bend rectification to set in. This, I think, would cause the effect in question.

F. L. C. FIRMIN (Lowestoft).

**Programme Time**

SIR,

Has not television been transmitted long enough now to deserve more than one-and-a-half hours per week? Surely now we can have at least one hour per day on our present-low-definition system even if it was only film transmissions. At present we poor amateurs, when needing to try out some idea, have a wait of three or four days to get a 45-minute programme. Then, if any adjustment is necessary, which may occupy a little time, we have another wait before another test is possible.

I feel sure your Journal and other readers could help to get more programmes, which are needed badly, even if it is only to let the Television Committee of the B.B.C. see they are wanted.

A. FRYER.

**SAVAGE  
TRANSFORMERS**

as specified by the Edison Swan Electric Co., Ltd., for use with their Cathode-ray Tubes.

- TYPE T.U.1. { 2000 volts 5 m/A. } Manufacturer's  
                  { 2 v. 1.5 amps. C.T. } Type 36/-
- TYPE T.U.2a { 1000 volts 10 m/A. } Manufacturer's  
(cancelling { 4 v. 2.5    4 v. 2.5 } Type 36/-  
T.U.2)        { amps C.T. amps.C.T. }
- TYPE T.U.3 { 35-0-35 v. 20 m/A. } Manufacturer's  
                  { 4 v. 2 amps. C.T. } Type 15/-

**W. BRYAN SAVAGE Ltd.**  
56/58, CLERKENWELL ROAD, E.C.1

Telephone: Clerkenwell 3068

**The Journal of the Television Society**

Published **THREE** times yearly by the Society—Subscription rate, 15/- per annum.

**PRICES OF BOUND VOLUMES**

Parts I to XII (Volume 1) of the *Journal of the Television Society* may now be had **BOUND** at the following rates:—

	Members of the Society.	Ordinary price, Non-Members.
<b>CLOTH</b> case in Blue and Brown, complete with Index and Title page ... ..	30/-	40/-
<b>FULL LEATHER CASE</b> (Rich Blue Colour) complete with Index and Title page ... ..	31/6	41/6
(Packing and Postage 9d. extra.)		

Single Copies of the **JOURNAL** may be had at 5/- per copy post-free or 2/6 per copy for Members of the Society.

**ORDERS** for **BOUND VOLUMES** to be sent to the Printers:

Messrs. Blacket, Turner & Co., Ltd.,  
34, Northbrook Street,  
Newbury, Berkshire.

**ORDERS** for single copies to be sent to the Editorial Secretary:—

W. G. W. Mitchell, "Lynton," Newbury, Berkshire.

# FOR QUALITY RECEPTION

Ask to hear on approval one of the latest models of Hyvolstar UNIVERSAL ALL-WAVE RECEIVERS. Fitted with the famous Ostar-Ganz Universal High Voltage Valves, they require no transformers, break-down resistances or barretters, as used by all other makers. Full range of

Supers, Straights, Band-Pass, Miniature Models, Transportable Radiograms, Quality Amplifiers for Television purposes and Short-Wave Adaptors.

These receivers are eminently suited for the present Baird 30-line Television System. High Definition (240-line) models are in preparation. Write for literature "T" and particulars of our approval scheme.

UNIVERSAL HIGH VOLTAGE RADIO LTD.  
28-29, Southampton Street, Strand, W.C.2  
Telephone: TEMple Bar 4985.

You'll get BETTER results with



ALL MAINS A.C./D.C. ANY VOLTAGE without alteration.

No need to guess—you can bank on peak results when you use the World's supreme UNIVERSAL HIGH VOLTAGE Valves. NO BARRETTERS, MAINS TRANSFORMERS or CUT DOWN RESISTANCES required. A valve for every purpose—without equal for Short-Wave Receivers and Television work.

The advanced design of Ostar-Ganz Valves is such that they may be successfully used for the reception of radio signals down to a wave-length of 2 METRES.

Write us for interesting leaflet.

EUGEN J. FORBAT, 28/29, Southampton Street, Strand, W.C.2  
Telephone: TEMple Bar 8608.

# SECURITY FOR SIXPENCE

Don't let that next overflow of current cost you shillings or pounds; fit Amplion fuses at all vital points and protect the life of valuable valves, transformers and other expensive components.

Amplion Cartridge Fuses. from 60 m/A to 3 Amp. for Battery or Mains sets cost only 6d. each.

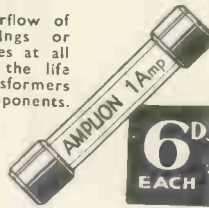

A reliable and constant form of resistance means consistent radio enjoyment. Amplion wire-wound resistances are "entirely dependable"—that's what "Popular Wireless" said after testing 22 different values.

Amplion Wire-Wound Resistances. 50 ohms to 100,000 and composition; wire-ends 1/2 meg. to 5 megohms cost only 1/- each (all values).

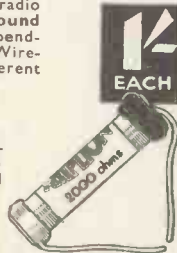

AMPLION (1932) LTD

Components, 82-84, Rosoman St., Rosebery Speakers and Sets. Avenue, London, E.C.1. Literature Free. Telephone: Clerkenwell 5440-5441.

# LONG DISTANCE POCKET RADIO

HIVAC have brought the miniature receiver into the sphere of practical radio by the introduction of a RANGE OF MIDGET VALVES.

The HIVAC XSG Screen Grid Valve—the only one of its kind makes possible a useful range of reception, thus removing the snag which has so completely restricted the use of "pocket radio." 15/6

The XD Detector Valve is suitable for R.C.C. or 10/6 transformer coupling.

The XL L.F. Valve possesses a degree of Sensitivity hitherto unattained in 10/6 Midget Valves.

All types have the low consumption of .06 amps at 2 volts.

Leaflet "T" gives full characteristics.



THE HIGH VACUUM VALVE CO LTD

113-117, Farringdon Road, London, E.C.1

## TELEVISION LAMP



Regd. 792977

25/-

### LAMP

1. The ONLY lamp for successful screen projection through discs.
2. Fluorescent glass, utilising 15% to 20% ultra-violet light which was previously lost.
3. Highest frequency-response of any gas-discharge lamp.
4. Enlarged gas-chambers and metal ends ensuring long electrical and mechanical life.



## 5 to 7 METRE VACUUM H.F. CHOKE



Prov. Pat No. 4406/35

4/6

### CHOKE

Impervious to changes in humidity. Impervious to damp. No shellac or other damp proofing dopes. No climate proofing losses. No air dielectric losses. Cannot change its value. Cannot "wander." Remains stable.

## TELEVISION INSTRUMENTS LIMITED

323 CITY ROAD, E.C.1

Telephones: Clerkenwell 0686

## PREFERRED by the EXPERTS B.T.S. SHORT WAVE COILS

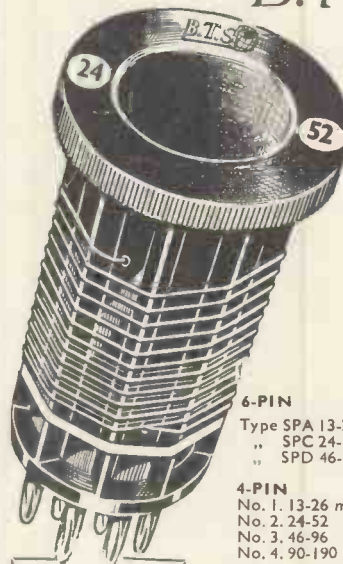

PRODUCT of the pioneer manufacturers of popular priced Short Wave Plug-In Coils. Expertly designed and constructed and consistently specified by the leading Radio Journals. Discriminating experimenters should refuse all imitations and insist upon B.T.S. . . . the choice of the experts. Send to-day for set of blueprints showing how to build 3 Short Wave Sets using B.T.S. Coils.

6-PIN

Type SPA 13-26 metres 4/6  
" SPC 24-52 " 4/-  
" SPD 46-96 " 5/-

SET OF 3

13/6

4-PIN

No. 1. 13-26 metres 4/-  
No. 2. 24-52 " 4/-  
No. 3. 46-96 " 4/6  
No. 4. 90-190 " 4/6

SET OF 4

16/-

FROM ALL DEALERS. If any difficulty, send direct. Ask for B.T.S. Short Wave and Television Lists.

# B.T.S.



BRITISH TELEVISION SUPPLIES, Ltd., Bush House, Dept. T2 London, W.C.2. Telephone: Temple Bar 0134.



# The Television Society

President: Sir Ambrose Fleming, M.A., D.Sc., F.R.S.

Hon. Secretaries: J. J. Denton, 25, Lisburne Road, Hampstead, London, N.W.5.  
W. G. W. Mitchell, B.Sc., "Lynton," Newbury, Berks.

At a meeting of The Television Society held at University College on April 10th. at 7 p.m., a paper was read by L. M. Myers, Esq., B.Sc. (Fellow), entitled "Kerr Cell Design for 240-line Reception." R. W. Corkling, Esq. (Fellow), occupied the chair. Following the paper, members took part in the discussion, all of which will be fully reported in the Journal of the society.

THE paper considered the necessary modifications in Kerr cell design for 240-line reception, both for direct television images and for inter-film exposing when the intermediate film method of reception is adopted.

The Karolus multiplate cell, which has found favour during the last few years, must now be abandoned owing to its prohibitively high self-capacity. It was shown that a normal type of multiplate cell needed 1,400 volt-amps. of wattless power to drive it at maximum picture-frequency in order that the contrasts for extreme definition should be satisfactory if not perfect. It is owing to the use of incorrectly-driven multiplate cells that the definition of many television pictures is decidedly below a satisfactory standard, and for intermediate film work this is even more pronounced. It is not yet universally recognised that the impossibility of obtaining good contrasts for high-definition long-shots is due mainly to badly designed Kerr cells and to ill-chosen electrical output valves.

To overcome all these difficulties it was recommended that the single pair of electrodes be used in future designs and in particular the type known as a Wright diverging electrodes. The retardation expression for the parallel electrodes is

$$\phi = \frac{B l V^2}{d^2}$$

where  $\phi$  = the retardation expressed as fractions of a complete wavelength.

B = the Kerr constant.

l = The length of the electrodes in centimetres.

d = the gap between the electrodes in centimetres.

V = the potential difference in electrostatic units.

The retardation for the Wright form of electrodes is similar to the above with the exception that the  $d^2$  is replaced by  $ab$ , where  $a$  = gap at centre, and  $b$  = gap at ends of electrodes.

The double-image polariscope as developed by the Marconi Company is particularly well adaptable to its use with the Wright form of electrodes, and

the incorporation of these electrodes needs but little modification in the optical layout.

## Biassing

A method of biassing the cell was then discussed in order further to reduce the wattless power required to drive the cell. This method entails an electrical half-wave forward bias with the electrical field with which is incorporated a quarter-wave backward optical bias with a mica quarter-wave plate. This

## Binding Cases and Indexes for 1934.

Binding cases and indexes for the 1934 volume of "Television and Short-Wave World" are now available. The binding cases are full brown cloth with stiff boards lettered in gold. The price, including the index, is 2/9 post free. Indexes may be obtained separately and the price is 6d. post free. Orders should be addressed—

**Bernard Jones Publications, Ltd.,  
Chansitor House,**

**37/38, Chancery Lane, London, W.C.2**  
and should be accompanied by the remittance.

means that for the negative half of the full signal voltage complete extinction is afforded, and for the positive half of the maximum signal voltage the resultant retardation is a half-wave for which maximum visual field illumination takes place. By this method it is possible to reduce the power by the factor  $\frac{1}{4}$  which represents the square of half the maximum signal voltage required to drive the cell on the first

FOR  
DISC AND MIRROR DRUM SYSTEMS  
"BAIRD" and "MERVYN"  
KITS AND COMPONENTS  
L. LEAMAN, 97, Northfield Avenue,  
W. Ealing, W.13.  
Phone—EALING 5394

operating slope, the latter method being in use up to the present day.

## Reducing Power Consumption

This indicates two methods of reducing power consumption, the third method brings the attention to the problem of preparing and purifying the nitrobenzene. The liquid should be subjected to the four following treatments: (a) Treat with a weak basic solution to remove acid traces; (b) treat with a drying agent to remove water; (c) fractionally distil under reduced pressure; (d) fractionally freeze.

To remove the acid, potassium carbonate solution is used; to dry, calcium chloride is mixed with the liquid and removed later by filtering. The process of fractional distillation is performed with any well-known fractionating still heads of the Hempel, modified Young or Vigreux type. Generally speaking it is found most convenient to fill the still head with small pieces of broken glass tubing. The first 40 per cent. of the distillate is discarded and the second 40 per cent. collected. Fractional freezing is then carried out of the remaining liquid. It is suspended in a bath of melting ice until a little over half is frozen, care being exercised that supercooling does not intervene. When these processes have been carefully carried out the breakdown strength of the nitrobenzene should be in the order of 6,000 volts per millimetre and the conductivity should not be less than  $10^{-11}$  ohms per centimetre.

By these means it is possible to reduce the power to drive the cell at maximum frequency for 240 lines at 25 pictures per second from 1,400 volt-amps. to about 200 volt-amps.

Following a hearty vote of thanks accorded to Mr. Myers, the latter part of the evening was devoted to a discussion, continued from the March meeting on "Recent Improvements in Cathode-ray Tubes, with particular reference to Television." The discussion was conducted by G. Parr, Esq. (of Messrs. Edison & Swan, Ltd.), this also will be reported in the Society's Journal.

The next meeting will be held on May 8, at 7 p.m., at University College, W.C.2.

## SHORT-WAVE BROADCASTS FROM EAQ.

The International Short-wave Club states that a special short-wave broadcast is to take place on Saturday, May 5, from Radio EAQ, Madrid, Spain, on a wavelength of 30.43 metres. This transmission is being split into two sections, section 1 between 19.00 and 20.00 G.M.T. and section 2 between midnight and 00.30 G.M.T.

Reports should be sent to Arthur E. Bear, International Short-wave Club, 10 St. Mary's Place, Rotherhithe, London, S.E.16.

**AUSTRALIA RECEIVED  
DIRECT ON THE UNIT RADIO  
CHASSIS BUILT  
SHORT WAVE CONVERTER-ADAPTOR**

This remarkable feat has been accomplished by satisfied users of the UNIT RADIO S.W. converter in conjunction with their own receiver. WHY NOT make your receiver all-wave and enjoy the thrills of S.W. listening? The UNIT RADIO S.W. converter is suitable for any type of receiver, mains or battery operated, without the use of extra batteries.



**NO ALTERATIONS  
SIMPLY PLUG IN.  
CASH  
C.O.D.  
OR  
H.P. 39/6**

Send for illustrated  
Leaflets.

**UNIT RADIO 347, CITY ROAD,  
LONDON, E.C.1  
CLERKENWELL 5340.**

**H. E. SANDERS & CO.**

SUPPLY ALL APPARATUS OF THE  
LATEST TYPE.

COMPONENTS FOR THE JUNIOR  
30 LINE RECEIVER AS DESCRIBED  
IN THIS ISSUE.

NEW TYPE MOTOR, universal, 1/2 in.  
double spindle. Price 21/-.

SCANNING DISC, 1 1/2 in. 1/2 Bush.  
Price 6/-.

VARIABLE RESISTANCE, NEW  
TYPE, 2,500 ohms. Price 7/6.

MERAGO FLAT PLATE LAMP, low  
striking voltage. Price 7/6.

COMPLETE KIT. Post free, 42/-.

SYNCHRONISING GEAR as described  
in this issue. Hold your pictures with  
"SANDERS" PEDESTAL TYPE.

Complete with NEW TYPE PHONIC  
WHEEL. Price 25/6.

"SANDERS" NON-DISTORTING  
BI-CONVEX LENS, 4 in. 4/6, post 6d., or  
5" 7/6, post 6d.

PHOTO-ELECTRIC CELL, GAS-  
FILLED TYPE 7. This is the cell for  
Television Transmission. 140 micro-  
amperes per lumen. Price 75/-.

HANDBOOK "EASY LESSONS IN  
TELEVISION." 1/9 post free.

Send for Latest Illustrated List

**H. E. SANDERS & CO.**

4, GRAYS INN RD., LONDON, W.C.1

Telephone—Chancery 8778.

**MISCELLANEOUS  
ADVERTISEMENTS**

The charge for advertisements in these columns is 12 words or less 2/-, and 2d. for every additional word. All advertisements must be accompanied by remittance. Cheques and Postal Orders should be made payable to Bernard Jones Publications Ltd., and crossed, and should reach this office not later than the 15th of the month previous to date of issue.

**PATENTS, Trade Marks, Advice.** Handbook and Consultations Free.—B. T. King, Patent Agents, G.B., U.S.A. and Canada, 146a, Queen Victoria Street, London. 48 years' references. Phone: City 6161.

**A. MATHISEN, Chartered Patent Agent, F.Tel.S.** Patents, Designs and Trade Marks.—First Avenue House, High Holborn, W.C.1. Holborn 8950. Telegrams: "Patam" Holb., London.

**AMERICAN RADIO PUBLICATIONS.** Callbooks 6/-; Who's Who in Amateur Radio, 3/- Handbooks (1935 revised edition), 4/6, all post free.—G5KA, 41 Kinfauns Road, Goodmayes, Essex.

**SALE.** Baird Parts Drum Televisor and Receiver. Gives good pictures. Seen running by appointment. Offers.—Major Thompson, "Syncona," Woodham Lane, West Byfleet.

**THE POLYTECHNIC**

307-311 Regent Street, W.1.

Electrical Engineering Department  
(Wireless and High Frequency Section)

A Special Course of Four Lectures on

**TELEVISION**

will be given by

**H. J. BARTON-CHAPPEL, Wh.Sch., B.Sc.,  
A.C.G.I., A.M.I.E.E.,**

On Monday evenings, 6.30-8.0, beginning 20th May,  
1935.

The lectures will be illustrated by experiments, lantern  
slides, and demonstrations on low and high definition  
television receivers.

**FEE FOR THE COURSE — 6/-**

Syllabus on application to the Director of Education.

**INDEX TO ADVERTISERS**

Amplion (1932), Ltd. ... ..	303
Automatic Coil Winder & Electrical Equipment Co., Ltd. ... ..	297
Belling & Lee, Ltd. ... ..	Cover ii
British Television Supplies, Ltd. ... ..	303
British Institute of Engineering Technology ... ..	295
Bryan Savage ... ..	302
Bryce, Andrew W., & Co. ... ..	242
Bulgin, A. F., & Co., Ltd. ... ..	241
Edison Swan Electric Co., Ltd. ... ..	Cover iv
Eugen J. Forbat ... ..	303
Ferranti, Ltd. ... ..	242
Foyles ... ..	Cover iii
High Vacuum Valve Co., Ltd. ... ..	303
Hummel, M. & S. ... ..	300
Jackson Bros. (London), Ltd. ... ..	301
Leaman, L. ... ..	304
Lectro Linx, Ltd. ... ..	241
Marconi's Wireless Telegraph Co. ... ..	242
Newnes, George ... ..	299
Peto Scott ... ..	297
Radio Resistor Co., Ltd. ... ..	298
Radio Society of Great Britain ... ..	301
Sanders, H. E., & Co. ... ..	Cover iii
Sound Sales, Ltd. ... ..	241
Stratton & Co. ... ..	295
Television Society ... ..	302
Television Instruments, Ltd. ... ..	303
Tungram ... ..	Cover ii
Unit Radio ... ..	Cover iii
Varley ... ..	301
Westinghouse Brake & Signal Ltd. ... ..	Cover ii
Wright & Weare, Ltd. ... ..	301

**THE CONSTRUCTORS'  
CIRCLE**

**Application for Membership**

To be filled in and sent with a  
stamped envelope for reply to the  
Editor, "Television and Short-wave  
World," Chansitor House, Chancery  
Lane, London, W.C.2.

- (1) I already subscribe to your journal at the address below.
- (2) I have placed a regular order for TELEVISION and SHORT WAVE WORLD with my book-sellers, Messrs.....

and desire to be enrolled as a member of the TELEVISION and SHORT WAVE WORLD. "Constructors' Circle."

Please send membership badge free of charge to

Name (in block letters) .....

Address .....

\*Strike out lines not applicable.

**FOYLES**

Booksellers to the World

New and secondhand books on every subject.  
Catalogues free on mentioning your interests.

119-125 Charing Cross Rd., London, W.C.2.

Telephone: Gerrard 5660 (10 lines)

**Constructor's Circle**

**Additional Members.**

W. L. Graham, 150 Westminster Road, Birmingham, 20; E. Clark, 31 St. Albans Crescent, Woodford Green; S. T. Russell, 157 Sandhurst Road, Catford, S.E.6; E. Beddow, Greenfield, Wem Lane, nr. Wem, Salop; R. Phillips, 9 Cazenove Road, Stoke Newington, N.16; J. F. Black, 6 Mill Street, Somercotes, Derbs; A. Bristow, 2 Victoria Road, Sittingbourne, Kent; J. D. Buckley, 3 Cresswell Terrace, Lightcliffe, Halifax; W. S. Miller, Main Street, Limavady, Ulster; J. H. Clarke, "Yarra, Yarra," 9 Northwood Road, Tankerton; S. R. McKinnell, "Greystones," Cook Ridge, Leeds; H. Dabell, 184 St. Anns Well Road, Nottingham; F. W. Freer, "Eltery," The Northern Road, Great Crosby, Liverpool, 23; Chr. Christensen, c/o S. G. Saetvedt, Fredrikstad, Norway; W. P. Bartrip, 53 Wendling Road, Sutton, Surrey; H. M. Koopman, 77 Lauriston Road, S. Hackney, E.9; A. Witted Atkinson, 40 Riversdale Road, Hull; Carl Jaeger, 220 Emerson Street, Houston, Texas, U.S.A.; W. Pearce, 27 Hollingbury Rise, Brighton; J. A. Smithies, 72 Turves Road, Cheadle Hulme, Stockport, Cheshire; D. R. Gardiner, Southwold Road, Wrentham, Beccles; A. J. Harris, Church Road, West Liss, Hants; John H. Collinge, 30 Horace Street, Whitefield, Burnley; J. A. McKean, Lynholm, Forest Hall, Northumberland; R. Jones, 1 Cumberland Drive, Hinckley Wood, Esher, Surrey; D. Lodge, Gears Farm, Cann, Shaftesbury, Dorset; J. H. Taylor, 18 Balmoral Grove, Rhyll; H. Middleton, "Woodview," Castle Bank, Stafford; H. Goddard, 303 Gosling Way, Normandy Road, Brixton Road, S.W.9; A. R. Grant, Ardownie, Monifieth, Angus; L. E. Baker, 25 Staverton Road, Oxford; H. R. Hastings, Saddlebow, King's Lynn, Norfolk; D. B. Cook, Highbury, Eigen Crescent, Mayhill, Swansea; W. J. Blake, Millhaven, Melbury, Shaftesbury, Dorset; Victor Cartwright, 5 Chalk Farm Road, Camden Town, N.W.1; F. Davy, 14 Tile Street, Bury, Lancs.; T. Elvy, 3 Clare Road, Whitstable, Kent; C. W. Barrett, Dunston, nr. Norwich, Norfolk; J. C. Manser, 11 Clitherow Road, Brentford, Middlesex; J. P. Phillips, 24 Bullergrove, Harehills, Leeds, 9; W. Fisher, 29 Lincoln Road, Smethwick, Birmingham.





Manufacturers of  
Electric Lamps  
By Appointment

# EDISWAN



Manufacturers  
and Purveyors  
of Electric Lamps  
By Appointment



Ediswan Ray Tube  
Price £8.8.0

Ediswan Mercury Vapour  
Relay. Price £1.15.0  
Ediswan MR/AC.1 gas  
discharge triode for use  
in sweep circuits  
associated with the  
tube.

## HIGH VACUUM CATHODE RAY TUBES

This new high vacuum device supplies the need for a tube of long life and improved modulating characteristics suitable

*for*  
*and* **TELEVISION  
RADIO RESEARCH**

We invite enquiries for :

- Mercury Vapour Rectifiers.
- Grid controlled discharge tubes for time bases.
- High Vacuum Diodes.
- Transmitting Valves, low and medium powers.

Full information on the tube and its associated circuits can be obtained on application to the Technical Service Dept. at the address below.

# EDISWAN RADIO VALVES

THE EDISON SWAN ELECTRIC CO. LTD.  155 CHARING CROSS ROAD, LONDON, W.C.2

**USED BY ALL GOVERNMENT DEPARTMENTS**

Printed in Great Britain for the Proprietors and Publishers, BERNARD JONES PUBLICATIONS, LTD., Chansitor House, Chancery Lane, London, W.C.2, by THE PRESS AT COOMBELANDS LTD., Adlestone, Surrey. Sole Agents for South Africa: CENTRAL NEWS AGENCY, LTD. Sole Agents for Australia and New Zealand: GORDON AND GOTCH (AUSTRALASIA), LTD.