

FOR THE BEGINNER — HOW THE RECEIVER WORKS

TELEVISION

THE FIRST TELEVISION JOURNAL IN THE WORLD

and **SHORT-WAVE WORLD**

MONTHLY 1/6

APRIL, 1936

No. 98. Vol. ix.

BERNARD JONES PUBLICATIONS LTD.,
CHANSITOR HOUSE, CHANCERY LANE,
LONDON, W.C.2.

TELEVISION— TELEPHONE

Articles on German Post Office system and on London-store demonstration.

SHORT WAVES

For the Beginner. What is needed for transmission; practical constructor requirements.

MECHANICAL FILM TRANSMISSION

A convincing analysis of Scophony system.

B.B.C.'s CHARTER

Leading points of Committee's report and review of television position.

90 Illustrations



THE TELEVISION TRANSMITTER INSTALLED AT THE WEMBLEY LABORATORIES OF THE GENERAL ELECTRIC COMPANY FOR RESEARCH IN RECEIVER DESIGN



Said a wireless-enthusiast named Drewsett,
"My complaint was unfair—please excuse it;
Since using **FLUXITE**
The Set's working all right;
I advise other grumblers to use it."

See that **FLUXITE** is always by you—in the house—garage—workshop—wherever speedy soldering is needed. Used for 30 years in government works and by leading engineers and manufacturers. Of Ironmongers—in tins, 4s., 8d., 1/4 and 2/8. Ask to see the **FLUXITE SMALL-SPACE SOLDERING SET**—compact but substantial—complete with full instructions, 7/6. Write for Free Book on the art of "soft" soldering and ask for Leaflet on **CASE-HARDENING STEEL and TEMPERING TOOLS** with **FLUXITE**

TO CYCLISTS! Your wheels will NOT keep round and true unless the spokes are tied with fine wire at the crossings and **SOLDERED**. This makes a much stronger wheel. It's simple—with **FLUXITE**—but **IMPORTANT**

THE FLUXITE GUN

Is always ready to put fluxite on the soldering job instantly. A little pressure places the right quantity on the right spot and one charging lasts for ages
Price 1/6.

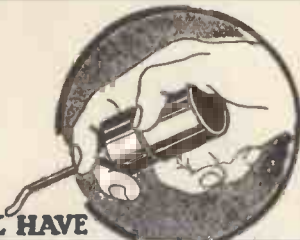

ALL MECHANICS WILL HAVE

FLUXITE

IT SIMPLIFIES ALL SOLDERING

FLUXITE LTD. (Dept. T.V.), DRAGON WORKS, BERMONDSEY ST., S.E.I.



Price each
17/6

**FOR INCREASED
EFFECTIVE H.F. &
I.F. AMPLIFICATION**

The
OSRAM
VMP4G

More stable amplification,
greater frequency range
and increased gain.

WRITE FOR
PARTICULARS

Osram Valves

MADE IN ENGLAND

Advt. of The General Electric Co., Ltd., Magnet House, Kingsway, London, W.C.2.

MULTI CONNECTORS

10 - PIN

Regd. Design.

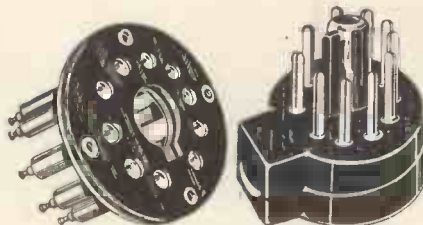

THIS carefully designed plug is specially suitable for connecting power pack to chassis, amplifier to receiver, etc. All metal parts silver plated and self-aligning. The flex part is in bakelite with locating key and side entry cord grip. No single pin can make contact until locating key has found its position the right way round. Can be connected with eyes shut. Single screw assembly. Shielded socket entry. Two contacts are widely spread for carrying mains. Such an attractive line that it is well worth using even with a number of idle pins.

No. 1251. Price complete 3/6

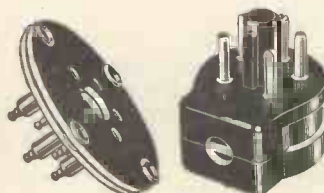

5 - PIN

Patent Regd.
Design.

This Connector is similar in design to the 10-pin type described above.

No. 1260. Price complete 2/6

3 - PIN

Designed for connections between receiver chassis and loud speaker. Centre tap speaker transformers; field coils with connection for earthing speaker chassis, or 3 wire arrangements to carry speech and energising currents to speaker. Three-pin Plug in bakelite complete with socket panel.

No. 1119. Price each 1/3

Plugs only.

No. 1107. Price each 9d.



Patent



BELLING-LEE
FOR EVERY RADIO CONNECTION

Belling & Lee, Ltd., Cambridge Arterial Road, Enfield, Mddx.

Please send, post free, the complete Catalogue, "Radio Connections."

NAME

ADDRESS

Tel. 4-36.

FOR THE WALLERIAL



Ugly aerial poles can now be supplanted by inconspicuous but highly efficient apparatus at small cost by using the "Bulgin Wallerial." It can easily be erected, either vertically, horizontally, or otherwise, on the side of the house.

The kit includes upper and lower wall-fixing insulators, ten ring-spacers and wire for a 6-strand 15-ft. aerial.

List No. L.8. 7/6 complete.

SCREENED

For use with high efficiency valves, this Shielded Connector is the very thing for use in the modern receiver. In two types, both having adequate insulation and spun aluminium screen with cable lug.

List No. P. 64, Shallow; List No. P. 65 Standard, 6d. each

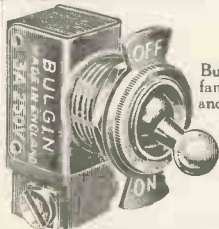

ON-OFF

Bulgin On-Off switches are famous for their reliability and sound design. In the large range of switches will be found a type exactly suited to the needs of the moment. List No. S.80. On-Off Toggle Switch Q.M.B., and substantial Terminals. Rating 250v. 3A. List No. S.80. 1/6 each

A Small Selection

Advt. of A. F. Bulgin & Co., Ltd., Abbey Road, Barking, Essex. 1el, Rippleway 3474 (3 lines).

TRIMMERS



For those few extra uF. you want these small Precision Mica Trimmers. They are built on "Ceramide" bases; specially selected mica is used and the design is such that they definitely "stay put." Readily held by the wiring they are very "low-loss." Perfectly reliable in both quality and performance

List No. Max. Cap. Price.
S.W.95 30 uF. 1/- each.

RECOMMENDED
AGAIN & AGAIN
BULGIN
QUALITY RADIO
AND TELEVISION
COMPONENTS

COUPON

To Messrs. A. F. Bulgin & Co., Ltd.,
Abbey Road, Barking, Essex.

Please send me Catalogue No. 155 "M" for which I enclose 3d. stamps

NAME.....

ADDRESS.....

(BLOCK LETTERS PLEASE)

S.W.I.F.

Bulgin Short Wave Components, of which there is a very large range, enable the enthusiast to obtain amazing results and ensure, with trial circuits all possible success.

Here is a coil of 2,200 uH. for 1.F. tuning in an adaptor. It may be tuned with .0003 uF. fixed or .0005 uF. max. pre-set.
List No. S.W.50 Price 2/6 each.

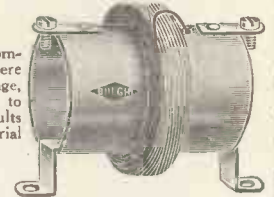

PLUG-IN COILS

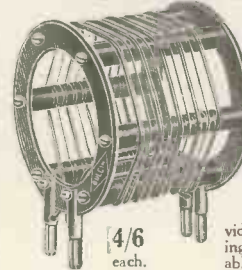

For experimental work the open type plug-in Short Wave Coils are easily interchangeable and can be tapped direct with a crocodile clip. Bulgin coils are wound on large dia. low-loss formers and provided with a reaction winding in addition to the tuneable grid coil. Tune with .0001 or .0005 uF. 0.00015

List No. Range List No. Range
S.W.35 ... 10-22m. S.W.37 ... 40-87m.
S.W.36 ... 20-45m. S.W.38 ... 80-180m.

FOR ALL PURPOSES

Indicating dials of pleasing appearance are a great asset, both in usefulness and as a decoration.

With a matt black general appearance with satin-aluminium characters and divisions. Hole dia. 3/8 in.

Indications for every use ... 3d. each.



From a Large Range

Showrooms: 64, Holborn Viaduct, E.C.1.

REPUTATION!

In last month's issue we published a list of some of the range of Sound Sales chokes and we spoke about the exacting duties they have to perform. Now in this month's issue you will see that because of their "high merit performance" they are specified for the



**U.H.F. 112-28 Mc
SUPER-HET**

Ask your dealer for
SOUND SALES
Type 30v
30 Hy CHOKE
14/-

FOR COMPLETE RANGE OF SOUND SALES CHOKES, TRANSFORMERS, ETC., SEND FOR ILLUSTRATED CATALOGUE "T.S."

SOUND SALES LTD.

Marlborough Road, Upper Holloway, London, N.19.
Phone: Archway 1661-2-3. (Contr. to G.P.O., etc.)

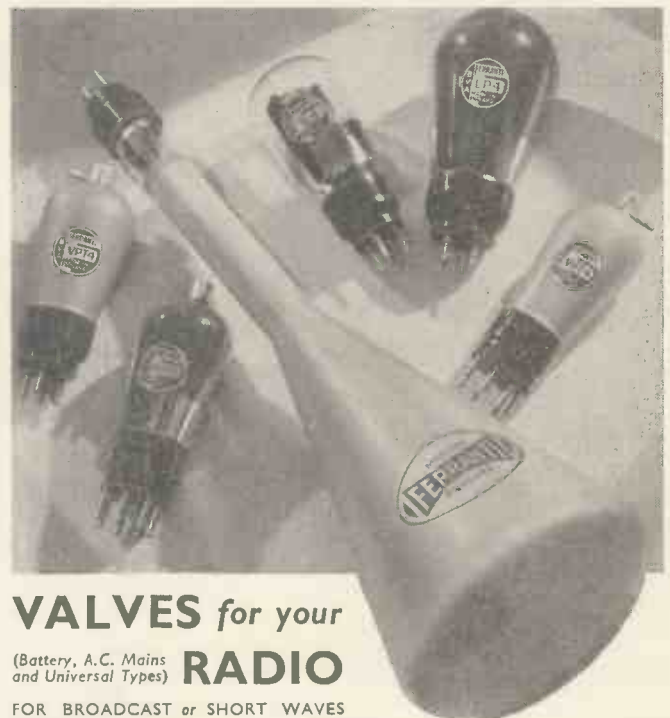

VALVES for your RADIO

(Battery, A.C. Mains and Universal Types)

FOR BROADCAST or SHORT WAVES

FERRANTI CATHODE RAY TUBES

for TELEVISION and INDUSTRIAL USE
FINEST DEFINITION and LONGEST LIFE
Working Voltage 1000/6000. Cathode
1 volt. 3 amps.

FERRANTI LTD.
RADIO WORKS, MOSTON, MANCHESTER, 10



VALVES

IF YOU USE 35^M/_M OR 17.5 FILM

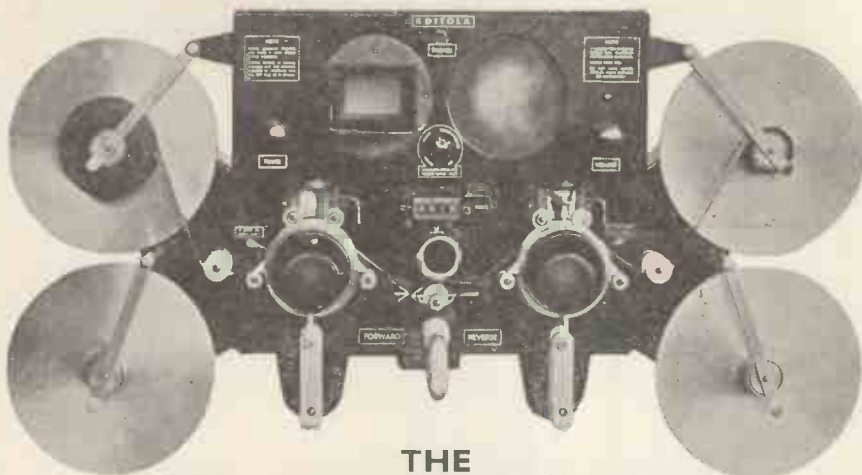

SPECIAL FEATURES

Entirely self-contained all mains 200-250v. A.C. Quiet in operation.

Takes combined print, separate picture and track, 17.5 sound track or short rolls with equal facility.

Simple and open threading with both apertures fully accessible.

Self-checking take-offs with immediate and simultaneous take-ups.

Reversing pre-set veeder counter with single picture indicator.

Easy manual propulsion for syllable or slow picture scanning.

Spool and flange models or both.

Excellent sound with ample volume.

Centralised and simple switching control with instantaneous starting and stopping and immediate reverse.

Damage to film practically impossible negative may be run with minimum possible risk.

Totally enclosed. Practically fool proof and maintenance negligible.

Guaranteed one year against faulty manufacture. Service available.

REGISTERED

“EDITOLA”

TRADE MARK

ALL-PURPOSE FILM EDITING MACHINE

MADE IN



IS INDISPENSABLE



ENGLAND

PRICE: **£215** EX WORKS

THE PHOTOGRAPHIC ELECTRICAL Co., Ltd., 80, WARDOUR St., W.I.

GER. 1366

Handymen!
are **HANDIER**
with a **SOLO**

ELECTRIC soldering is simpler, safer, surer.

SPEEDY Plug into any lamp-holder - ready in three minutes.

EFFICIENT Element clamped inside the bit, assuring maximum heat at the point of the bit - the spot where you want it.

7/6
(65 WATTS.)

Sold complete with instruction book, resin cored solder, 6ft. of flex and standard lamp-holder adaptor.

INDUSTRIAL MODEL

9/6 (65 watts).

Fitted with 3-core Tough Rubber Flex-provision for earth connection.



SOLO
ELECTRIC
SOLDERING IRON

Obtainable from all good class ironmongers and stores. In case of difficulty apply direct to:—

W. T. HENLEY'S TELEGRAPH WORKS CO. LTD.,
Dept. 35YAB, Holborn Viaduct, London, E.C.1.

FOR CIRCUITS IN THIS
ISSUE USE

362

SG2	Battery Screen Grid Valve	7/6
ACHL4	A.C. Mains Triode	7/6
ACSG4	A.C. Mains Screen Grid ...	12/6
ACHM4	A.C. Mains H.F. tetrode with pentode characteristics ...	13/0
ACVP4	A.C. Mains Short Base Var. Mu. H.F. pentode (7-pin)	13/0

THE VALVES THAT ARE
GUARANTEED
FOR SIX MONTHS

THE 362 RADIO VALVE CO. LTD.,
STONEHAM WORKS, E.5.

Clissold 6607

TELEVISION

and SHORT-WAVE WORLD

Special Features

	Page
Lorenz 180-line Receiver	196
A 37-56 Megacycle Signal Generator ...	197
The Scophony System	201
Phone and Television	205
Recent Television Developments ...	207
Self-contained Five-metre Transmitter	209
Efficient Aerial Termination	212
Electron-coupled Frequency Meter	213
Farnsworth Demonstrates 1000-watt	
Multipactor Tube	215
Germany's Television Telephone ...	216
An Ultra-high Frequency Super-het	220
The Television Signal—From Aerial	
to Tube	224
Transmitting for the Beginner ...	226
The G.E.C. and Television	227
The Principles and Practice of Elec-	
tron Optics	229
Amateur Bands Single-signal Super	
Reception and Transmission of Ultra	
High-frequencies	233
Experimental Short-wave S.G.-V-Pen	236
A Power Pack for Small Receivers ...	237
Digests and Data	239
Fluorescent Screens for Cathode-ray	
Tubes	241
The Broadcasting Committee's Report	246

TELEVISION AND SHORT-WAVE WORLD

Proprietors :

BERNARD JONES PUBLICATIONS, LTD.

Editor-in-Chief :

BERNARD E. JONES.

Editor :

H. CORBISHLEY.

Editorial, Advertising and Publishing

Offices :

Chansitor House, 38, Chancery Lane,
London, W.C.2.

Telephones : Holborn 6158, 6159

Telegrams : Beejapee, Holb., London.

Subscription Rates : Post paid to any
part of the world—3 months, 3/6;
6 months, 6/9; 12 months 13/6.

Published Monthly—1/- net.

(Last Wednesday in every month for
following month).

Contributions are invited and will be promptly considered. Correspondence should be addressed according to its nature, to the Editor, the Advertisement Manager, or the Publisher, "Television and Short-wave World," Chansitor House, Chancery Lane, London, W.C.2.

IMPORTANT

"Television and Short-wave World" is registered at the General Post Office, London, for transmission to Canada and Newfoundland by Magazine Post.

COMMENT OF THE MONTH

"Lack of Control."

IN a plea for launching a co-operative campaign of advertising on behalf of the radio trade, made in the course of a speech delivered at the Radio Luncheon Club, on February 26, by Mr. G. J. Freshwater, of the Marconi-Phone Co., Ltd., he said, according to a report appearing in *World's Press News*, that "thanks to the complete lack of control on television publicity, masses of people are marking time, expecting the improbable to happen at any moment, and you begin to get some idea why some of us think that a co-operative campaign should be organised within this industry."

We find it extremely difficult to understand what Mr. Freshwater has in mind. If he is suggesting that somebody or other should have prevented the Press from mentioning television he must entertain extraordinary views of the position of the Press in this country. In such a sense as he suggested there can be no control of publicity on any subject affecting the life and leisure of the people, although, truth to tell, pressure has been brought to bear on the popular Press to cause it to use the "soft pedal" when referring to television.

If all he meant was that the great companies and interests should have prevented any news leaking through to the Press, then, again, his words are just as difficult of comprehension because that is almost exactly to-day's position.

Getting information on the subject of television out of anybody who has any to give during the past twelve months has been like getting blood out of a stone. The B.B.C. refused all information until quite recently, when we were extremely gratified at what appeared to be their change of policy, but whether it was a real change or just a spasmodic variation it is difficult to say. No information has been obtainable from them during the last month or two, and generally we state a fact when we say that on a subject in which an enormous number of the radio public is interested it is well-nigh impossible at the present moment to extract any information from the officials and authorities who have the matter of television in hand. And when we come to the companies whose systems of television will be operated by the B.B.C., we are in much the same position; they will tell us hardly anything.

"Lack of Control!" In the whole history of scientific and technical development in this country, we very much doubt if there is any instance of such controlled publicity as there has been in the case of television—and at a moment, we remind all concerned, when we are on the very threshold of a public television service.



THE LORENZ 180-LINE RECEIVER

The Lorenz receiver is all contained within a framework which allows of all parts being easily accessible. Both vision and sound are combined in the one instrument.

THE Lorenz Company, of Berlin, have recently issued details of their television receiver intended for the Berlin transmissions of 180 lines, 25 pictures per second. The instrument combines sight and sound and, as the photograph shows, the whole job is compact with the parts readily accessible. It is intended for vision reception on approximately 6.5 metres.

The receiver operates with a high-vacuum cathode-ray tube, operating with a plate voltage of 5,000 volts. The electron beam is deflected in the vertical direction electromagnetically and electrostatically in the horizontal direction. Grid-controlled rectifiers (thyratrons), each followed by a single stage amplifier, generate the saw-tooth waves for the scanning and image-change.

The vision signals are received and amplified with a superheterodyne having four stages of intermediate frequency amplification, each stage having a band filter capable of passing 500 kilocycles with uniform am-

plification. A Braun tube serves as a second detector and its ray potential is controlled by the receiver.

Synchronising

The synchronising signals are filtered out and provide image and line impulses, which are, of course, utilised for synchronising the saw-tooth waves for picture and line frequencies.

The sound signal is received on a regenerative detector and two-stage audio amplifier feeding a dynamic speaker. The power supply for the entire apparatus is designed for a 220-volt mains supply, and consumes approximately 330 watts.

As will be seen from the photograph, on the upper front panel of the receiver is the image screen, designed for a 19 x 22 cm. size image; below is the loud speaker grille.

There are four main controls in two pairs. The pair on the left are for sound (tuning and regeneration) and the right pair control the image (tuning of the heterodyne in television re-

ceiver and input amplitude adjustment).

On the outer right-hand side, below, is the main (on-off) switch, controlling the entire receiver. In the rear are the power line plug, and sockets for earth and aerials. Two sockets are provided for connecting a dipole, which can be used advantageously when general receiving conditions are unfavourable. It is stated that ordinarily a simple short aerial is satisfactory for receiving at normal distances from the transmitter.

Controls are provided for contrast and maximum sharpness. When the television receiver is improperly tuned, or when the transmitter is not operating, the image screen is dark. No other adjustments of the screen or of the image brightness are necessary. If the television receiver is properly tuned, then it is stated everything else automatically operates correctly, and once the television receiver has been so tuned, only the on-off switch need be operated for both vision and sound reception.

It is not intended that this receiver be sold through the regular dealer distribution channels, since the success with which the receiver can be used depends upon the relation of the transmitter to the desired receiving location. The makers suggest that all those interested in obtaining one of the instruments should get in touch directly with the manufacturer.

The National Field Day

THE annual R.S.G.B. Contest will this year be held from 16.00 G.M.T., June 6, until 19.00 G.M.T., June 7. The event is restricted to English, Welsh, and Scottish districts in addition to the Irish Free State and Northern Ireland.

Each district taking part will be permitted to use two separate stations, one operating in the 40- and 20-

metre bands and the other on 80 and 160 metres.

Power supply has to be obtained from batteries or generators powered from accumulators, as the domestic supply mains must not be tapped.

Stations must not be erected in habited buildings, neither must the aerial be more than 45 feet from the ground. This is to prevent some stations erecting the aerial on the top

of tall buildings so obtaining an unfair advantage over other stations.

Last year the contest was won by district 8 under the leadership of the D.R. G5FB. This district includes Herts, Beds, Bucks, Cambs and Hunts.

It is particularly requested that both receiving and transmitting stations make quite sure that no interference is caused.

A 37-56 MEGACYCLE SIGNAL GENERATOR

A TEST GEAR FOR TELEVISION RECEIVER DESIGN

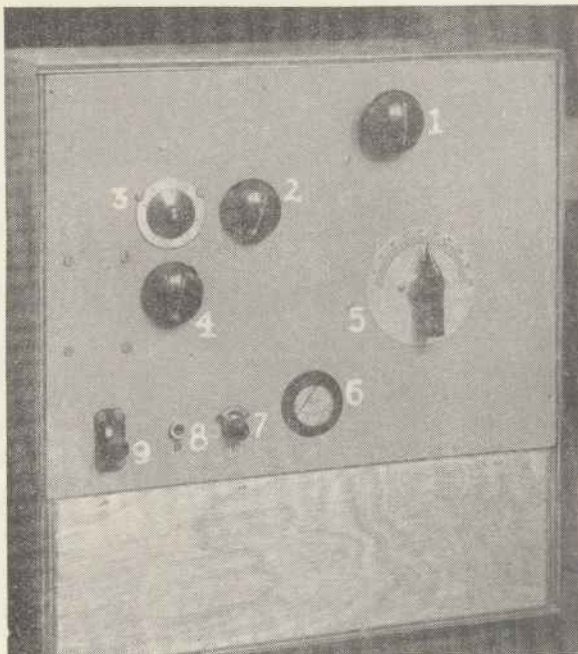

1. 37-56 megacycle tuner.
2. 37-56 grid leak.
3. Ferranti 10-pole switch.
4. Mod.-oscillator control.
5. Wavemeter.
6. 0-15 milliamp meter.
7. Mod.-oscillator switch.
8. Headphone jack.
9. On-off-on switch.

actual pictures. Actually no information has been published as to the tolerances of phase and amplitude over the large band of frequencies.

First let us consider the generation of the carrier frequency. After various hook-ups were tried out, the circuit shown in Fig. 1 was found to be most satisfactory. It should be borne in mind that not more than the 66-volt dry cell and 2-volt valves were to be used. It will be observed that the tuning inductance consists of two equal inductances, L and L_1 , which are joined in an A.C. sense by the condenser C , which must be of large capacity compared with that of the valve capacities, the inductances being tuned by C_1 . No coupling is required between L and L_1 as the necessary reaction is brought about by the valve capacities. The high-frequency chokes L_2 , L_3 , L_4 and L_5

THE problem of making a receiver for the new television service is undoubtedly a difficult matter and one of the greatest problems is the fact that there is no transmission to try it out on, except perhaps a few amateurs on five metres, which is rather far removed from the 6.6 metres (vision) and 7.23 metres (sound) of the new service. Further, any transmissions which one might pick up can never be relied upon to be there just when

eight frequencies being approximately 25, 6,000, 50,000, 100,000, 500,000, 1,000,000, 1,500,000 and 2,000,000 modulating a carrier of from 40 to 50 megacycles.

With such a signal generator both the pre and post detector stages of a television receiver can be tested for their general amplitude response, by nothing further than the simplest form (even uncalibrated) of valve voltmeter.

Phase distortion, however, is another matter, which in some respects will only be proved when receiving

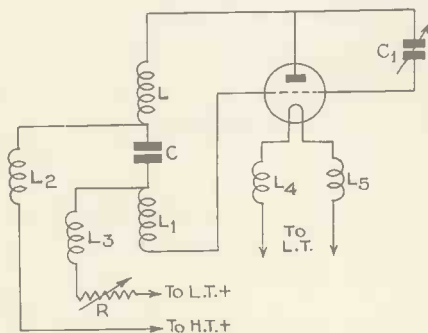
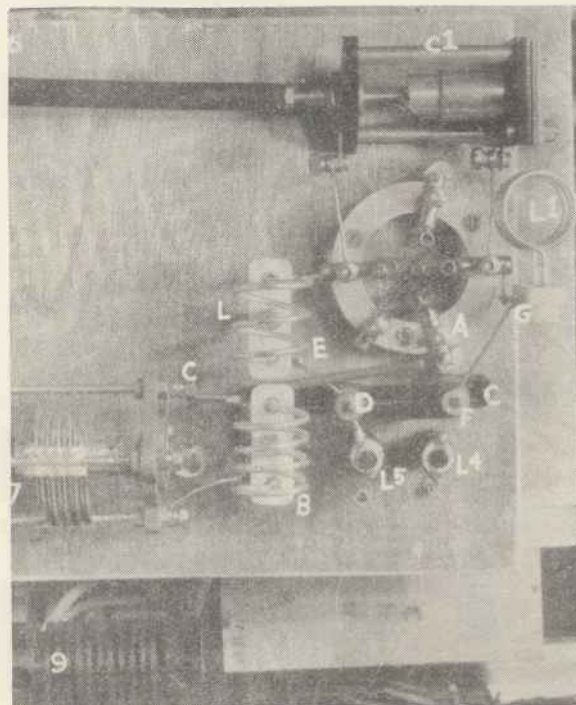

Fig. 1.—High-frequency oscillator circuit suitable for 37-56 megacycles.

wanted and therefore some sort of signal generator becomes necessary. Such a generator must produce the required carrier frequency and if possible be modulated over the range of high-definition television, that is from about 25 to 2,000,000 cycles.

In the apparatus to be described, eight different frequencies were considered sufficient to give a fair idea of how a receiver was behaving, the



- Close-up view of 37-56 Mega-cycle oscillator. Refs.:
- C 300 mmfd., fixed condenser.
 - C_1 neutralising condenser.
 - L 5-turn anode coil.
 - L_1 5-turn grid coil.
 - L_4 high-frequency choke.
 - L_5 ditto.
 - A negative filament lead.
 - 8 6-turn absorption coil of wavemeter.
 - 9 Varley Junior choke, medium frequencies.
 - Length of wire joining F G and D E $1\frac{1}{2}$ ins.
 - Length of wire joining coils L and L_1 to anode and grid of valve holder, $\frac{3}{8}$ in. each.
 - Length of wire joining wavemeter condenser and coil, $\frac{3}{8}$ in. each.
 - Separation between coil L and absorption coil bases, $\frac{1}{8}$ in.

A SIGNAL GENERATOR FOR RECEIVER DESIGN

are of the quarter-wave type. R, the variable grid leak completes the circuit. Such a circuit will oscillate most satisfactorily with an H.T. of about 60 volts, using a Mazda L₂

ments are given. These also should be followed as closely as possible; the resistance R in Fig. 1 is not shown as it is mounted in the modulator section.

To overcome this a further choke is put in series in the H.T. lead as in Fig. 4b. As this additional choke will, with the two capacities C and C₁, have some resonant frequency in the form of an acceptor circuit, care must be taken not to have the modulating frequency similar to the resonant one.

The transformer of Fig. 4 a and b can be replaced with the grid coil of a valve oscillator as in Fig. 4c, and such was the method originally proposed for producing and modulating the carrier oscillator. Unfortunately the grid current of the carrier oscillator passes through the modulator grid coil and when used with coils wound on iron, as for 25- and 6,000-cycle range, erratic effects were produced and it was decided to be perhaps somewhat extravagant and use another valve as in Fig. 5, which, incidentally, shows the whole of the circuit used except that only one set of coils is shown in the modulating frequency oscillator. This, however, is shown separately in Fig. 6. This looks much more complicated than it really is owing to the necessity for showing the eight different frequency generators, also a transformer for modulating with an audio signal.

The variable resistance R controls the intensity of the oscillations. This modulation signal oscillator must be screened as in addition to causing disturbance on the broadcast band it

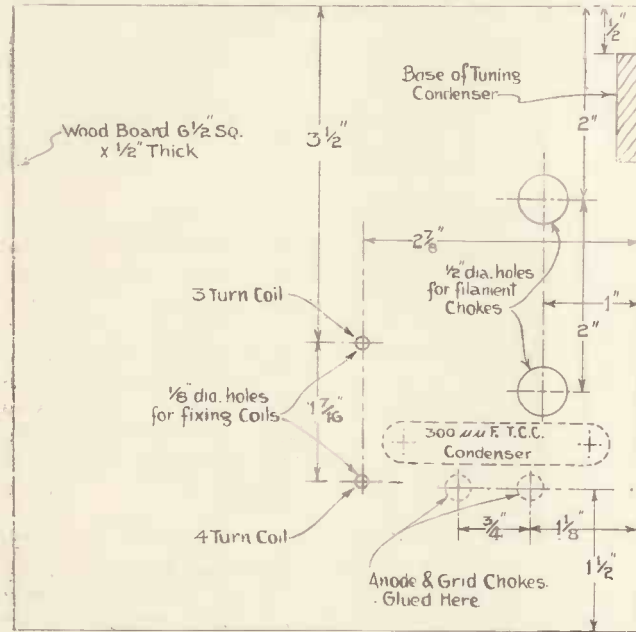

Fig. 3.—Details of wooden baseboard on which carrier oscillator is mounted. Board 1/2 in. thick.

valve (metallised). The actual physical layout of this circuit is shown in Fig. 2. Here, it will be observed, are an extra condenser and inductance which form an absorption wavemeter.

This absorption circuit if carefully duplicated in layout and components can be relied upon to give similar results to the one illustrated, thus giving the constructor a definite means of knowing what frequency is being generated. The actual condenser is the "Eddystone" "scientific" short-wave condenser with maximum capacity of 35 mmfd. the inductance being a six-turn coil made by the same firm.

Fig. 3 is a plan of the necessary holes for the various components which go to make up the oscillator and these measurements should be strictly adhered to for the absorption meter to be similar to the writer's instrument. The extension handle of C₁ was prepared from 1/4-in. ebonite rod, one end being drilled and tapped with a 2 B.A. thread.

It may be mentioned that Eddystone make a satisfactory extension outfit which could be conveniently used. In Fig. 2 certain measure-

To modulate the circuit of Fig. 1 to audio frequencies is very simple. All that is necessary is to insert one winding of a transformer in series in the grid lead as shown in Fig. 4a, and the voltage developed across the transformer being developed across the grid produces grid modulation of

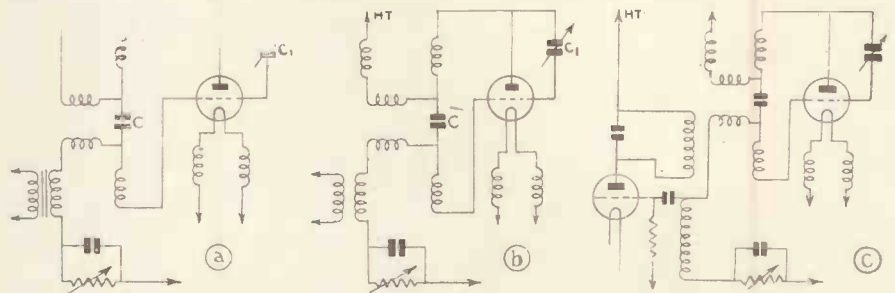

Fig. 4.—(a) Modulating with speech and music—audio frequencies. (b) Modulating with radio frequencies (c) Modulating frequency oscillator coupled to carrier oscillator.

the oscillator. If the frequency of the modulation signal is raised until it becomes what is loosely termed a radio frequency, the reactance of C and C₁ falls and as the frequency is further raised virtually produces a short circuit and no voltage is developed between grid and filament, the oscillator no longer being modulated.

might be picked up direct on the receiver which was being tried out by the aid of the apparatus.

Fig. 7 gives an idea of the general layout. The coils are wound on the usual shellaced cardboard tubes 2 ins. in diameter and 2 1/2 ins. long, particulars of the windings being given in the table.

A SIGNAL GENERATOR FOR RECEIVER DESIGN (Contd.)

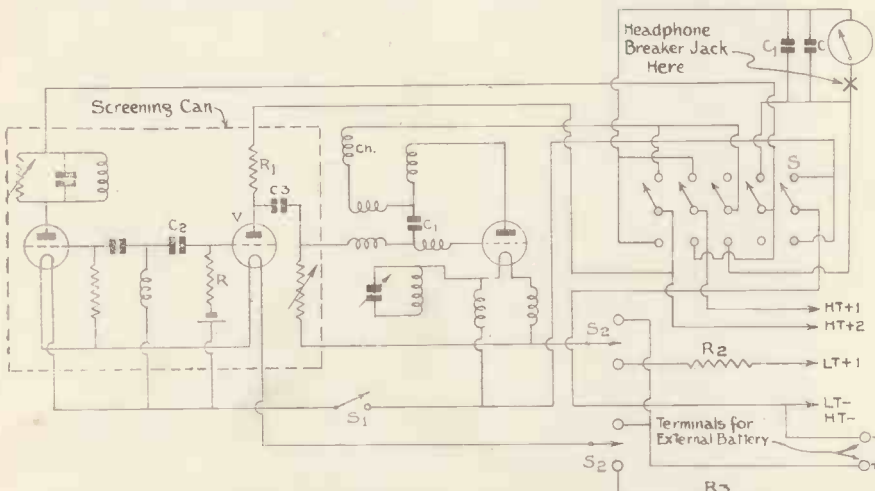

Fig. 5.—Circuit of modulated 35-45 megacycle oscillator. Only one set of modulating oscillator coils shown for the sake of clearness.

The windings to produce 6,000 and 25 cycles are somewhat of a problem. The writer used one of the original Ferranti intervalve transformers with 4-mfd. across the primary for the

circuit. Constructors must remember to connect all coils in the right sense to produce oscillations.

If no old transformers are available, the writer would suggest two

Bulgin midget L.F. transformers with about .0001 mfd. and a .4 mfd. across the primary for 6,000 and 25 cycles respectively. The transformer marked T in Fig. 6 is the usual step-down transformer fitted to small moving coil speakers, being wired to produce a step-up in volts, which is necessary if the usual radio receiver output is used for modulation purposes. Various switching arrangements are shown in Fig. 5. S is a three-position 5-pole double throw switch, "on," "off," "on," putting each oscillator anode current through the meter M as required. S₁ is a separate control for modulation signal generator. S₂ is a double pole double pole switch for switching the 3-volt dry battery L.T. to an external battery such as a 2-volt accumulator.

Four batteries are housed in the wooden cabinet, shown by Fig. 8, they are two 66-volt H.T. and two 3-volt L.T. No constructional details are given of the screen box of the modulation frequency oscillator as these can be made according to individual skill in such matters; the writer's was made of tinfoil.

Table of Coil Windings

2,000,000 cycle	L = 26	L ₁ = 4	turns
1,500,000 cycles	L ₂ = 38	L ₃ = 5	turns
1,000,000 cycles	L ₄ = 64	L ₅ = 8	turns
500,000 cycles	L ₆ = 64	L ₇ = 10	turns

The above coils are all single layer wound, the reaction winding being wound over the low (A.C.) potential end.

100,000 cycles	L ₈ = 300	L ₉ = 60	turns
50,000 cycles	L ₁₀ = 300	L ₁₁ = 70	turns

It will be noticed that the above two coils are similar. The anode



37-56 megacycle oscillator unit with absorption wavemeter coils. Note: the two 3-turn coils should have 5 turns, and the 4-turn 6 turns in order to go up to the R.R.C. 7.75 transmissions from Broadcasting House.

anode coil and the secondary; for the grid coil for 25 cycles and for 6,000 cycles an old 2,000-ohm headphone bobbin and original pole pieces, with the windings separated and .004 mfd. across one coil for the anode coil were used. These produced the required note, but when coupled to the carrier-frequency oscillator, as in Fig. 4c, refused to produce a signal, apparently because of the relatively heavy grid current flowing through the grid coil. It was, of course, quite satisfactory when used in the final

Fig. 6. (Right).—Circuit of 8 fixed frequencies oscillator. The frequency required is chosen by a 2-pole, 10-position switch. It will be noted that 9th position selects a transformer, the valve no longer being operative, while the 10th prevents any frequency being produced.

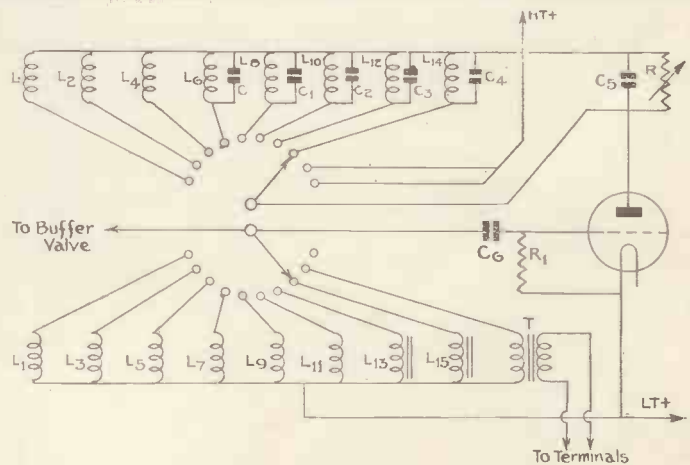

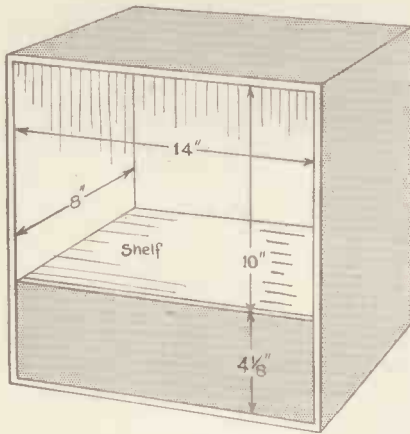

Fig. 8.—Details of cabinet; lower section contains batteries.

coil being pile wound the first layer having some 70 turns with four layers wound over it making five in all. The reaction winding being wound over the final top layer.

All coils are wound with wire giving some 65 turns per inch—30-gauge double silk covered or 36-gauge double cotton covered.

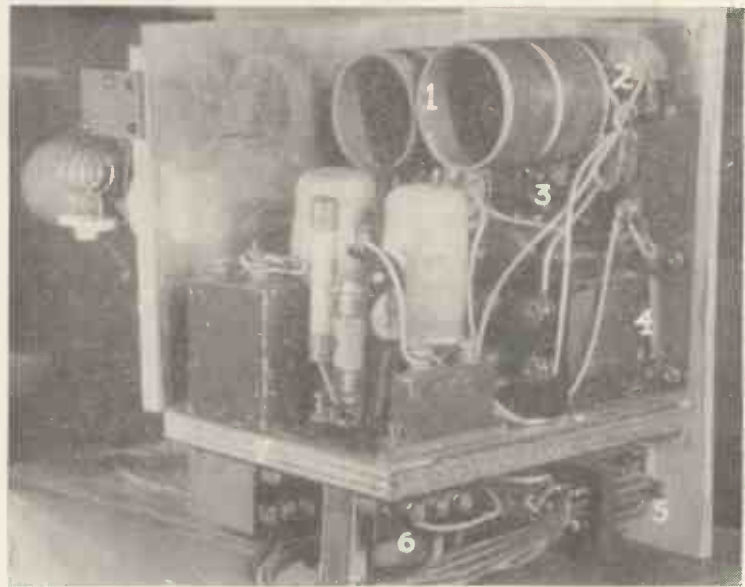

Fig. 7.—Modulating frequency oscillator generator and modulating buffer valve. Picture taken during construction, before construction was complete.

1. Anode and grid coils, two sets per former. Third former behind valves.
2. Fixed condensers behind coils.
3. Ferranti Ten-way switch.
4. Old inter-valve Ferranti transformer.
5. Meter switch.
6. Audio transformer.
7. Baseboard metal lined $7\frac{1}{2}$ by $5\frac{3}{4}$.

VALUES OF COMPONENTS IN SIGNAL GENERATOR

Carrier Oscillator. Figure 1.

L and L₁ = 5-turn "Eddystone" Coils.
L₂, L₃, L₄ and L₅ = home-made chokes consisting of 55 turns each on $\frac{3}{8}$ in. wooden dowel rod, L₂ and L₃ 30 s.w.g., and L₄ and L₅ 22 s.w.g.

C = 300 uuf. T.C.C. mica condenser.
C₁ = Jackson neutralising condenser.
R = 100,000-ohm wire-wound potentiometer used as variable resistance.

Valve holder, Eddystone.
Valve, Mazda L₂.

Modulation Oscillator. Figure 6.
Switch, double-pole ten-position, Ferranti.

C = 300 uuf. mica.
C₁ = 500 uuf. mica.

C₂ = 2,000 uuf. mica.
C₃ = according to winding L₁₂, see text.
C₄ = according to winding L₁₄, see text.
C₅ = 100 uuf. mica.
C₆ = 20,000 uuf. mica.
R = .5 megohm variable.
R₁ = .2 megohm.
Valve, Mazda L₂.

Figure 5.
Meter = Bulgin miniature 0-15 m.a.
C = 1 mfd. condenser.
C₁ = 300 uuf. condenser.
C₂ = .1 mfd. condenser.
C₃ = .1 mfd. condenser.
R = .25 megohm resistance.
R₁ = 500 ohms resistance, metalised.

R₂ = 7.5 ohms = 14 yds. 36 copper wire.
R₃ = 3.75 ohms = 7 yds. 36 copper wire.
Choke, Varley Junior.
V = Mazda HL valve.
A = valve holder.
2—66-volt H.T. batteries (small type).
2—3-volt bell batteries (Woolworths).
1 Breaker jack, if wanted.
4 Terminals, 2 for external battery, 2 for sound input.

Also one 6-turns Eddystone coil and one Eddystone Scientific short-wave condenser, maximum capacity 35 uuf., for the absorption wave-meter, which is fitted with an Eddystone pointer knob and dial.

Practical Radio Communication by Arthur R. Nilson and J. L. Hornung (McGraw-Hill Book Company, Inc., Aldwych House, Aldwych). This is probably the most comprehensive work on wireless communication yet published. Its scope extends from elementary electricity to ultra-short-wave transmission and reception, and whilst it cannot be

regarded as an elementary treatise it is written in such a progressive manner that even the novice will be able to follow the more advanced parts with a reasonable amount of understanding. The subjects covered include direct-current electricity, magnetism, alternating-current electricity, vacuum tubes, transmitting circuit principles, receiving circuit principles, aerials and wave propagation,

studio acoustics, control room equipment, broadcast transmitters, communication transmitters, radio receivers, radio navigation, rectifier units, dynamos, meters, storage batteries, and much useful data and general information. It is a work that will be equally useful to the beginner or advanced student. It contains 754 pages and has over four hundred illustrations. The price is 30s. net.

MECHANICAL FILM TRANSMISSION

THE SCOPHONY SYSTEM

AN ANALYSIS OF ITS POSSIBILITIES

By L. M. Myers

This is the second article on the possibilities of film transmission by mechanical methods. Last month the simple apertured disc was discussed in detail and it is shown below that the Scophony system is sixteen times more efficient.

FOR the second example of high-definition mechanical optical film transmitter we take the Scophony system.

In order to understand the operation of the system we should first consider that of the so-called multiplying lens drum. In the case of the simple lensed film transmitter, a conveniently disposed aperture is imaged on the film gate by the lens in the disc and when the lens rotates with the disc, the image moves laterally across the face of the film. If the lens in the disc is positioned midway between the aperture object and the image on the film, then the light spot on the film will move twice as fast, thus covering twice the distance, as the lens.

The angle subtended by the width of the film scan on the axis of symmetry is termed the picture angle and it can be readily shown that if this picture angle can be increased the efficiency of the system is also increased. This fact is well exemplified in the Wilson multi-reflection system employed in conjunction with the moving mirror-drum. By arranging two reflections from the moving mirror-drum, the picture angle is increased four times and the efficiency rises in proportion. One would thus anticipate an analogous arrangement with the lensed disc by sending the light twice through the lens to increase the picture angle.

This multiplication can be accomplished with the lensed disc and a glance at Fig. 1 will indicate how this is carried out. In the first case the lenses are

mounted on a drum. If mounted on the disc, then some inconvenient reflecting system would have to be

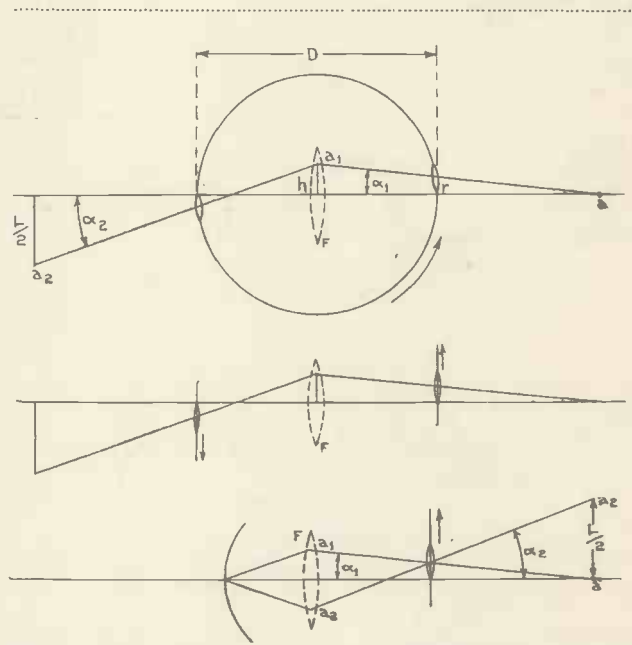

Fig. 1.—Three methods of setting up the multiplying lens drum or disc. A field lens at F is necessary to ensure the light passing through the second lens. The first system is the most convenient.

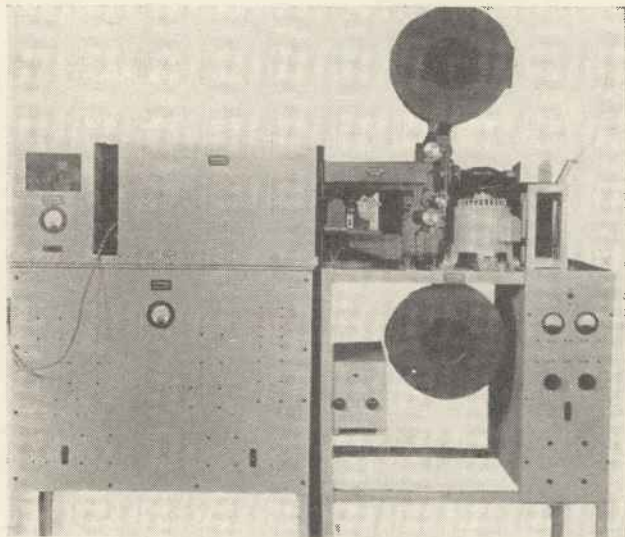

Fig. 4.—The Scophony film transmitter. The fifth cylindrical lens is to the left and its curvature is in a horizontal plane, the curvature of the others being in the vertical plane.

used to send the light a second time through the lens. If an aperture is disposed at a , then the first lens in the lensed drum with vertical axle will image this at a_1 , the subtended angle being α_1 . Now the opposite lens in the drum will image a_1 at a_2 with an increased angle α_2 , which now assumes the picture angle.

If lensed discs are to be used as seen below, they must rotate in opposed directions, thus they cannot be mounted on a common spindle. In the third diagram the system is illustrated with a single lens disc. The first image a_1 must be inverted and appear at a'_1 , if the scanning is to be effective. This is done with the aid of a concave mirror with the conjugate images at the centre of curvature. The angle α_1 is increased to α_2 , as before.

In all these cases the system will be useless without the employment of a field lens in the image plane to deflect the light into the second lens. This field lens is shown at F. As this lens is placed midway between the two scanning lenses its focal length should be one-quarter the distance between the scanning lenses.

THEORY OF THE SCOPHONY SYSTEM

Of the three arrangements shown, the first is obviously the simplest and most readily constructed. This optical arrangement is the basis of the Scopphony film transmitter in which case certain important modifications are introduced. The light source is at a and the light spot on the film is at a_1 , and conveniently disposed collector lenses throw the light passing through the film at a_1 on to the photo-cell. This is shown in Fig. 2. The system as it now stands, however, is extremely cumbersome and it is hardly likely that the construction of such a lensed drum would lend itself to very high speed operation.

Compressing the Beam

The situation has, however, been saved by the designers of the Scopphony system by hitting on the novel and perfectly legitimate expedient of compressing the

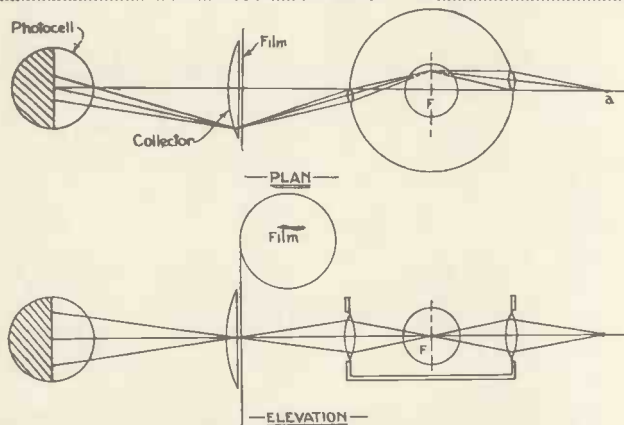

Fig. 2.—Further development of the multiplying lens drum as film scanner. The field lens is now in the form of a glass sphere.

light beam as it were in a direction normal to that of the scan. This can be accomplished without loss of light as we shall see. Compression in the scanning direction would inevitably result in light loss.

Turning to Fig. 3, we see a cylindrical lens CL_1 introduced between object and first lens in the drum, its purpose being to compress the light in a vertical direction, the scan being in the horizontal diagram. The lenses in the drum are now singlets which have been cut down to a central slice with boundary planes normal to the lens axis. The field lens at the centre of the drum is now in the form of a glass sphere which rotates with the drum and thus presents identical refracting surface to the oncoming light whatever its orientation. The light collected by this field lens now passes through the opposite lens in the drum. Two cylindricals, CL_1 and CL_2 , now deal with the light cone diverging from the second lens in the drum. They change the sign of the vergence and bring the light to a focus in the plane of the film. In the plan, as the first cylindrical lens is ineffective in this plane, so too are the second and third cylindrical lenses. This brings us to the surface of the film. Behind this there may be one single spherical collector lens to gather the light for the photo-cell or, alternatively, as shown here two cylindrical lenses in the crossed position. The first,

nearer the film, is of high power to deal with the strongly diverging beam in the vertical plane; this is the lens CL_2 .

The final lens CL_2 deals with the diverging light consequent on the horizontal scan and is of less power. These two final lenses can be readily seen in the photograph of Fig. 4. In this figure, the light source, which in this case of a 120-line transmitter is a small 70-watt thin filament exciter lamp, having a brightness in the order of 2,000 candles/cm² or less. This lamp is fed from the A.C. mains through a rectifying and smoothing circuit.

It will be remarked that the lensed drum, with sliced lenses, now assumes such proportions that a streamline casing is possible giving this rotating member an appearance of neatness and efficiency. At once the contrast between this and the ungainly aperture disc is apparent. The driving motor, running at 6,000 r.p.m. is small and of fractional horse power, and there is no obstacle to the use of a 9,000 r.p.m. motor with consequent increase in the optical efficiency.

Theory of the System

In order to calculate the theory of this system it is most convenient to take the case of the multiplying lensed drum stripped of the modifications peculiar to the Scopphony arrangement. As we shall see later, these important modifications do not affect the optical efficiency. As in the case of the simple apertured disc we shall let:—

B be the brightness of the light source in candles/cm².

n be the number of lines in the scan.

n_a be the number of lenses in the drum.

L be the length of the image on the film in the direction of scan.

K be the picture ratio; i.e., $K = \text{Length}/\text{Width}$.

N be the number of elements. $N = Kn^2$.

D be the diameter of the lens drum.

r be the radius of the lens in the drum.

a be that area of the light source corresponding to the area of the light spot on the film.

p be the speed factor, i.e., number of revolutions of drum per picture scan.

k be the aperture ratio of the lens in the drum.

Considering Fig. 1, we see that the amount of light in lumens entering the first lens on the drum is given by the product of the source brightness; the source area and the solid angle subtended by the lens at the source. This yields the well-known expression:

$$F = Ba\omega$$

where ω is the solid angle. This angle is given by

$$\omega = \frac{\pi r^2}{l^2}$$

As the system is symmetrical about a central axis, the area of the light spot on the film is equal to the corresponding area of the light source. If the scan were to be completed, giving a picture area A , then we could put

$$a = A/N.$$

But the area of the picture is expressed by

$$A = L^2/K$$

POSSIBILITIES OF THE SCOPHONY SYSTEM

so that we have

$$a = \frac{L^2}{KN}$$

giving

$$F = \frac{\pi Br^2}{KN} \cdot \left(\frac{L}{l_1}\right)^2$$

We have now to express the quantity in brackets in terms of the various dimensions of the system. From Fig. 1 we can write down from geometrical considerations

$$\frac{L/2-r}{l_1} = \frac{h+r}{l_1}$$

and

$$\frac{h}{l_1+l_2} = \frac{r}{l_1}$$

The first expression becomes

$$\frac{L-2r}{l_1} = \frac{2(h+r)}{l_1}$$

because, by symmetry,

$$l_1 = l_1 \text{ and } l_2 = l_2$$

This further reduces to

$$\frac{L}{l_1} = \frac{2h}{l_2} + 2r \left(\frac{1}{l_1} + \frac{1}{l_2} \right)$$

$$= \frac{2h}{l_2} + \frac{2r}{f} \text{ where } f = \frac{1}{\frac{1}{l_1} + \frac{1}{l_2}}$$

On substitution for h we find

$$\frac{L}{l_1} = 2r \left\{ \frac{l_1+l_2}{l_1 l_2} + \frac{1}{f} \right\} = \frac{4r}{f}$$

$$= \frac{2}{k} \text{ where } k = \frac{f}{2r}$$

Upon further substitution for the quantity in brackets in the above efficiency expression we have

$$F = \frac{\pi Br^2}{KN} \frac{4}{k^2}$$

But if D is the diameter of the drum then

$$\frac{\pi D}{n_d} = 2r$$

And, moreover, since $na = n/p$ we have

$$F = \frac{\pi^3 BD^3 p^2}{N^2 k^2} \text{ Lumens.}$$

If we now account for the optical transmission losses through the system by introducing the factor t we have for the final expression

$$F = \frac{\pi^3 BD^3 p^2 t}{N^2 k^2} \text{ Lumens.}$$

Comparing this with the efficiency of the simple high speed aperture disc we note that the efficiency of the

Scophony film transmitter is exactly 16 times as efficient.

Thus

$$F = \frac{\pi^3 BD^3 p^2 t}{4N^2 k^2} = A \text{ Lumens. Efficiency of simple apertured disc transmitter.}$$

$$F = \frac{\pi^3 BD^3 p^2 t}{16N^2 k^2} = A/4 \text{ Lumens. Efficiency of oper- tured disc film transmitter.}$$

$$F = \frac{\pi^3 BD^3 p^2 t}{N^2 k^2} = 4A \text{ Lumens. Efficiency of Scophony film transmitter.}$$

We shall consider now a particular case in practice wherein the light source has a brightness of 20,000 candles/cm² and a drum diameter of 20 cms. We cannot, however, take an aperture ratio of the lens in the drum equivalent to that of the objective in the case of the aperture disc because the lenses in the drum are not anastigmatically corrected, and such a high aperture ratio would not be compatible with good definition of the light spot on the film. Nevertheless, for the purpose of comparison with the previous case of the aper-

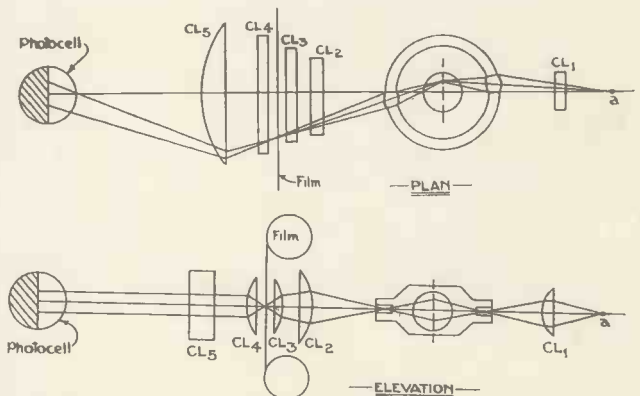

Fig. 3.—The Scophony film transmitter showing the use of cylindrical lenses to compress the light normal to the direction of scan. The first four cylindrical lenses are employed for the compression of the light. The fifth cylindrical lens, CL₅ acts as a collector for the light scanning in the horizontal.

tured disc transmitter we shall take the same aperture ratio of $f/2$. If we take the picture ratio as $K = 4/3$ and a transmission loss factor as $t = 0.1$ the efficiency expression reduces to $F = 35 \times 10^5 p^2/n^4$.

The curves of this expression, for different values of p, are found in Fig. 5 which gives complete information of the optical rating of the system.

Disadvantages of the System

It was pointed out in the discussion on the apertured disc film transmitter, that whereas the apertured disc was well suited to this purpose, the lensed disc, having identical efficiency, was unsuitable owing to the presence of uncorrected lenses in the disc. This argument applies with greater force in the case of the Scophony transmitter just considered. Here we have two lenses in the disc which have to form an image of the

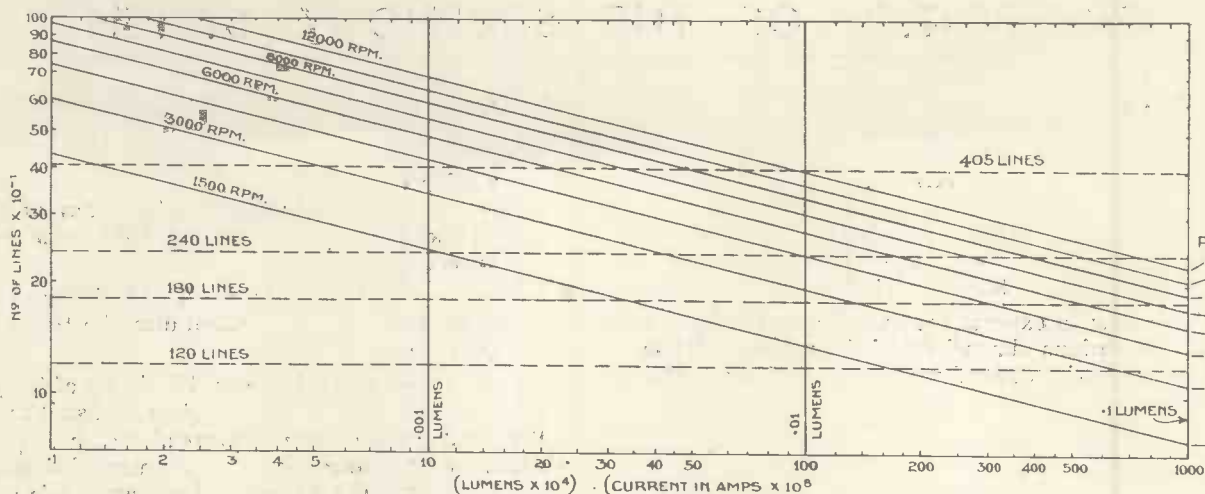

Fig. 5.—This gives complete information with respect to the amount of light reaching the photo-cell for different numbers of lines and for different motor speeds. Note that for 240 lines at a speed of 6,000 R.P.M. the amount of light reaching the cell is 0.018 lumens, which is an extraordinarily high value.

apertured light source on the film. These lenses cannot be corrected for coma and astigmatism as they are singlets mounted in the revolving drum.

Correction for these aberrations pertaining to skew rays cannot be satisfactorily accomplished with less than three elements in the lens. At the centre of the scan, the light rays can be considered substantially axial, but at the ends of the scan these rays are definitely askew as evidenced by the optical layout of Fig. 1. The light spot aberrations can be overcome for the longitudinal axis of the film but not for the lateral axis. To correct for the former axis, it is necessary only to introduce a horizontal gate of line width in the plane of the vertically moving film. In the lateral axis, however, there will assuredly be some flare. This flare will be accentuated by the employment of the cylindrical lenses which characterise this particular system. It must be

borne in mind that the spot width for a 240-line scan is in the order of one-tenth of a millimetre and to obtain such a spot with sharp definition is not easy even with the best of lenses, particularly when the image has to be sharp over the complete scanning line. It is the objective and not the film that is in motion.

It must be understood that the system described and discussed here is now over a year old and does not, therefore, represent the last word or the eventual stage of development of the Scophony Film Transmitter. No doubt this company have made progress since the construction of this model and what is stated here will not apply to more recent achievements.

Tribute must be paid to a system characterised by extreme ingenuity and one which deservedly takes a prominent place in the history of mechanical optical film scanning.

We submitted to Scophony Limited for their perusal the above article a few days before going to press. Shortage of time did not give Scophony Limited the opportunity to examine the calculations of the writer.

We are, however, asked by Scophony Limited to publish the following observations.—Editor

From Scophony Limited.

Owing to pressure of time, we are unable at this stage to make more than a casual reference to the article by Mr. L. M. Myers, which you submitted to us. We would, however, point out that the optical arrangements shown in Fig. 3 of the article on the Scophony High-definition Film Transmitter, are not quite an accurate representation of the Scophony film transmitter, as some of the stationary lenses cooperating with the rotating member have spherical surfaces.

An apparent error in the text is the assumption that the lenses in the Scophony scanning wheel are central slices of spherical lenses, whereas they are cylindrical lenses, with axes of curvature parallel to the axis of the wheel.

It is incorrect to suppose that oblique aberrations, such as coma and astigmatism, cannot be corrected in the Scophony transmitter. Not only is there no coma in a completely symmetrical system, but also the various stationary lenses are provided for the express purpose of correcting the material aberrations, both axial and oblique.

The employment of cylindrical lenses does not accentuate the difficulties of correcting for coma and astigmatism. On the contrary, in certain cases, of which the Scophony transmitter is an example, the utilisation of cylindrical lenses facilitates the removal of astigmatism from an optical system, since the difference between anastigmatic and ordinary types of lenses, usual in spherical lens practice, is almost meaningless in dealing with cylindrical systems.

PHONE AND TELEVISION

A DEMONSTRATION IN LONDON



The cathode-ray receiver installed in a booth; the viewing screen is a mirror placed at an angle of forty-five degrees.

WHAT was the first demonstration in this country of combined sight and sound *via* the phone was staged in London recently. This was in connection with the booking of seats for a new film at Selfridges. The intending purchaser of seats went into a telephone booth which was in semi-darkness, took a seat before a television receiver and immediately he picked up the telephone receiver there appeared on the screen of the cathode-ray tube a picture of the booking clerk, who proceeded to discuss his requirements. After the business was completed the telephone receiver was replaced and this had the effect of cutting the transmission off.

It was rather a pity that the whole of the apparatus employed was not on view instead of the receiver only, for the public are rather apt to take scientific marvels for granted and probably did not appreciate what this novel display represented. Of course, the entire transmission was by line, the receiver being in one part of the building and the transmitter in another, a matter of a couple of hundred yards distant.

The receiver was in a cabinet or booth which was in semi-darkness. It consisted of a cathode-ray tube in a glass case, the tube being arranged vertically with a mirror inclined at an angle of forty-five degrees above it. The image was therefore viewed in the mirror, the principal reason for this being to save space. The tele-

phone receiver was placed at one side of the cabinet. Below the actual receiver were the high-tension unit and the time-base.

The Transmitter

The most interesting part of the apparatus was the transmitter, which was situated in an upper part of the building. This consisted of a ninety-hole disc revolving in a wooden casing at 1,500 revolutions per minute. As one of the photographs shows, the subject (in this case the booking clerk) sits in front of this and is floodlit by two 6,000 candle-power projection lamps and two approximately

1,000 candle-power. As it was found that the heat from the two large lamps was somewhat disconcerting, large glass tanks filled with water were placed in front of these in order to absorb some of the heat.

Two photo-cells were employed, one for vision and the other for providing the synchronising impulses. The vision cell was placed immediately behind the disc at the top and the other was on the right-hand side, each being provided with amplifier.

The diameter of the disc was 30 inches with a calculated peripheral speed of nearly two hundred miles an hour. This was mounted directly on the shaft of a one horse power synchronous motor and no other attempt was made to keep this at a steady speed.

The disc was of aluminium 0.1 mm. thick and this extreme thinness introduced certain mechanical difficulties. One of the main troubles was a flutter or wobble which developed at the edge of the disc and travelled slowly round the periphery. This was eventually cured by providing special cardboard supporting discs on each side, an arrangement which also provided mechanical protection for the disc.

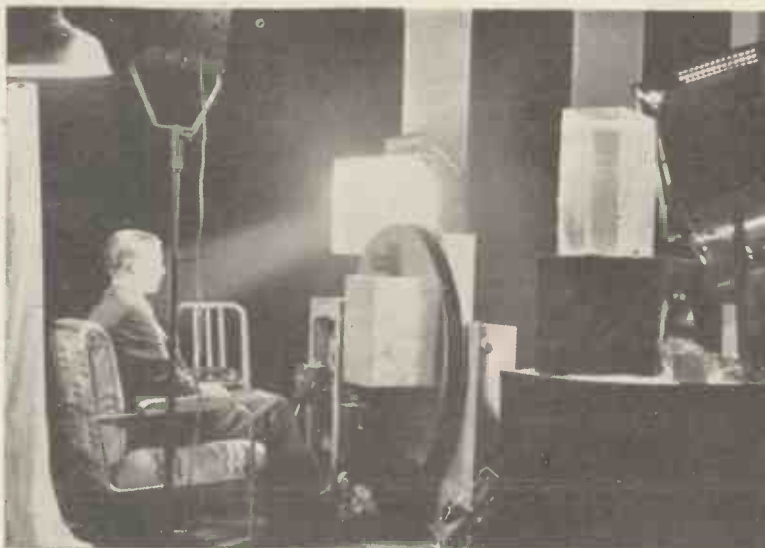

The general arrangement of the transmitter with the floodlights in position.



This photograph shows the scanning arrangements. The synchronising projector is contained in the case at the right and its photo-cell and associated amplifier at the rear. The vision photo-cell case can be seen at the back at the top and below this are the amplifiers.

stantly and were therefore permanently synchronised. The H.T. to the tube was only applied as required.

It will be obvious that only one-way transmission was attempted, the reason being that there was little object, considering the circumstances under which it was to be used, in having it both ways and also because difficulty would be experienced with the floodlighting, the light being so intense that it would have been practically impossible to see the picture on the screen of the tube at the same time. The designer of the entire equipment was Mr. J. H. Reyner, a regular contributor to this journal, and he is to be congratulated upon his effort.

No mention has as yet been made regarding the actual picture obtained. This, of course, had a definition of ninety lines and the tube employed (an Ediswan) was approximately seven inches in diameter. The colour was an excellent black and white and exceptionally bright. For close-ups, such as the head and shoulders, it is remarkable what a good degree of definition ninety lines gives. Occasionally there was a certain amount of distortion taking place which at times made the face appear as though it were being viewed in a curved mirror; this was attributed to disc wobble and except for this defect the picture was excellent and remained quite steady.

Two synchronising impulses were provided—one for the line frequency and the other for the picture frequency, appropriate apertures being cut in the disc for this purpose. In order to provide the light for these a small projection lamp of the small ciné type projected a strip of light on to the disc, the photo-cell, of course, being placed at the other side. All this gear is contained in the two cases which can be seen at the back and

front of the disc casing at the right-hand side. The main photo-cell for vision and its associated amplifier were contained in the wooden case at the back of the disc.

As it would be impracticable to start and stop the disc each time a transmission took place it was necessary to keep it running all day, the lifting of the phone merely switching off the transmission line; the time bases also were kept running con-

Broadcasting on the Amateur Bands

Although frequencies between 7,000 and 7,300 kcs. have been allocated to amateur experimenters we notice that several commercial or semi-commercial stations are using that band which is already too narrow.

VP3MR, in British Guiana, operates on 7,080 kc. EA8AB on 7,200, and CR6AA on 7,177 kc. HB9B are on the air two or three times a week on frequencies of 14,044, 7,022 and 3,770, while other real commercials such as DZH, LZA, etc., are either in or close to amateur bands. Some protest should be made at once otherwise this type of station will spread to all amateur bands.

9 Thursday	23.00	1990	G6AU
12 Sunday	00.00	1769	G5GC
12 "	11.00	7233	G5JL
12 "	11.15	1810	G6GC
16 Thursday	23.00	1990	G6AU

and Portsmouth were present and included G2VH, G2PS, G2XC, G5OH, G5PB, G6NZ, G6SS and G6WS.

The subject of the meeting was

WEAVED SCANNING ?

We have received this photograph from a Californian reader who describes himself as the originator of the helical mirrorscrew. No particulars are given of the photograph beyond the term "Weaved Scanner"

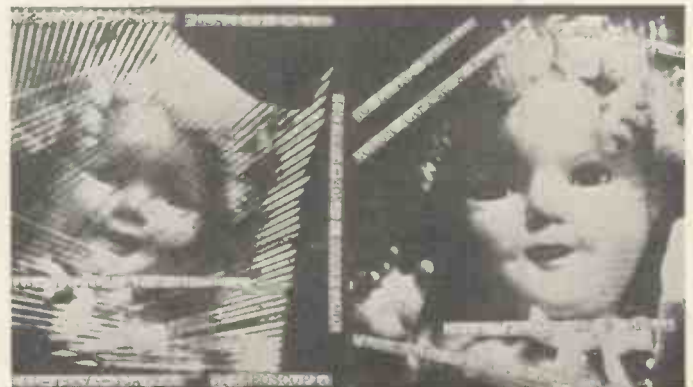

Slow Morse Transmissions for April

2 Thursday	23.00	1990	G6AU
5 Sunday	00.00	1769	G5GC
5 "	11.00	7233	G5JL
5 "	11.15	1810	G6GC

South Hants R.T.S. Society

The monthly meeting of the above Society was held at Fareham, Hants. Members and friends from Bournemouth, Southampton, Winchester

"Development of Radio Communication," which was illustrated by lantern slides. The lecturers, G6NZ and G2XC discussed the pioneer work of Hertz, Lodge, Fleming, Marconi and others.

RECENT TELEVISION DEVELOPMENTS

A RECORD OF PATENTS AND PROGRESS *Specially Compiled for this Journal*

Patentees :—C. O. Browne :: Scophony, Ltd., and J. H. Jeffree :: Fernseh Akt.
A. C. Cossor Ltd. :: R. J. Kemp

Mirror-drum Scanning (Patent No. 439,121.)

A rotating mirror M set at the centre of a circular mirror drum D is used to produce two separate sets of

light-cell C containing a transparent liquid, to which high-frequency mechanical vibrations are simultaneously applied by a piezo-electric crystal P forming the bottom of the cell.

extinguish the ray as it passes through the cell. The modulated ray is then thrown by a rotating mirror-drum D on to the screen K.

By causing the mechanical vibrations to set up a series of separate resonance waves or ripples, which may either remain stationary or move progressively forward through the liquid, it is possible to produce a number of interesting effects. For instance, a series of picture-points may be projected simultaneously on to the viewing-screen so as to increase the average illumination. Or a continuously-moving cinema film can be scanned with the same effect as if the film were fixed instead of in motion. Finally, a complete picture can be transmitted simultaneously in a series of lines, which are superposed first on different sub-carrier waves and finally on a single "master" carrier-wave. —(Scophony, Ltd., and J. H. Jeffree.)

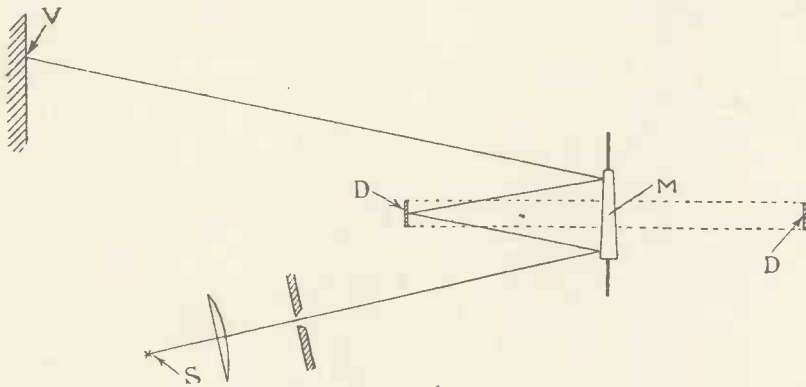

Mirror-drum scanning. Patent No. 439,121.

scanning lines which are then interleaved. Light from a source S is first thrown on to the rotating mirror M, which reflects it on to one of the fixed mirrors of the drum, from which it is thrown back on the mirror M, and finally on to the viewing screen V. Each of the fixed mirrors is progressively inclined, so that the ray of light is swept over the picture in a series of lines which are spaced apart by the width of one line.

All this takes place during the time one face of the rotating mirror M is in operation. After it has rotated through 180°, the opposite face comes into play, and this, as shown, is inclined to the first face. The consequence is that the second series of scanning-lines are slightly displaced on the screen V, so as to occupy the spaces left between the first series of lines. The fixed mirrors on the drum D are spaced so as to complete the interleaved scanning of each picture in 168 lines.—(C. O. Browne.)

Scanning Systems (Patent No. 439,236.)

A ray of light from a source S is modulated by passing it through a

The mechanical vibrations create alternate regions of compression and rarefaction in the liquid, and these cause diffraction or interference effects which partly or completely

Focusing the Electron Stream (Patent No. 439,414.)

In order to utilise the electron stream in a cathode-ray tube to best advantage, at least two electrostatic

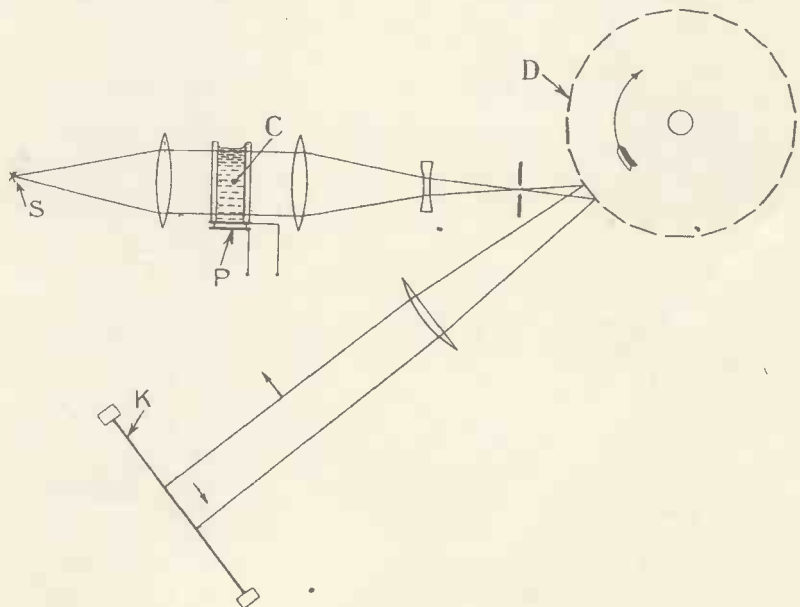

Scophony scanning system. Patent No. 439,236.

The information and illustrations on this page are given with permission of the Controller of H.M. Stationery Office.

lenses are interposed in its path from the cathode C to the fluorescent screen F. The first lens L is placed comparatively close to the cathode so that the focusing potentials need not be large, since the stream is still of small cross-section. The second or main lens-system L_1 comprises an aper-

modulation by the voltages applied to the scanning electrodes.—(*Fernseh Akt.*)

Cathode-ray Tubes

(Patent No. 439,636.)

To increase the sensitivity of a cathode-ray tube a pair of special de-

impulse applied at A to the grid of a valve V_2 . The synchronising impulse alters the plate current flowing through two magnetising coils F, F_1 wound outside each of the tubes D; D_1 . The resulting change in the strength of the magnetic field ionises the gas inside the bulb, and suddenly makes it conductive. This allows the condensers C, C_1 to discharge, thereby applying a saw-toothed scanning-voltage to the plates of the cathode-ray tube.—(*Marconi's Wireless Telegraph Co., Ltd., and R. J. Kemp.*)

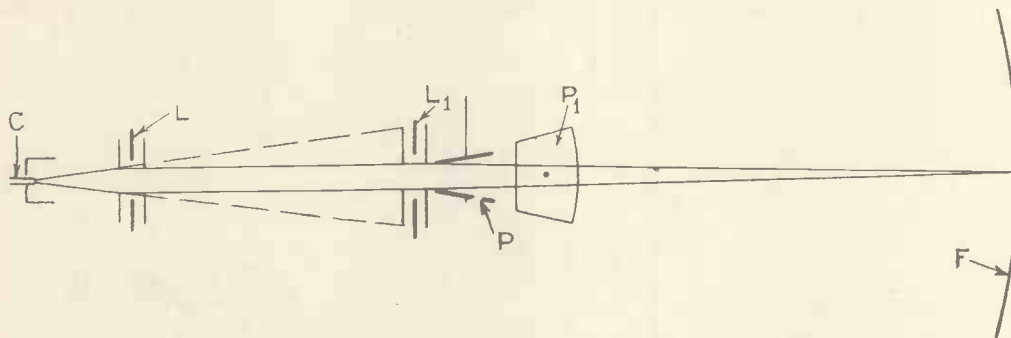

Focusing the electron stream. Patent No. 439,414.

tured diaphragm which also serves to shield the deflecting-plates P, P_1 from stray electrons.

When the stream is modulated, by deflecting or cutting it off from the

deflecting-electrodes are arranged on the cathode side of the anode. The usual Wehnelt cylinder is replaced by a box-like structure of four plates, two of which serve as the first pair of deflectors. The anode is slit in the direction of deflection, and the

second pair of deflecting electrodes are arranged close to the other side of it. In this way the anode serves as a screen or shield to prevent capacity coupling between the deflector plates.—(*A. C. Cossor, Ltd.*)

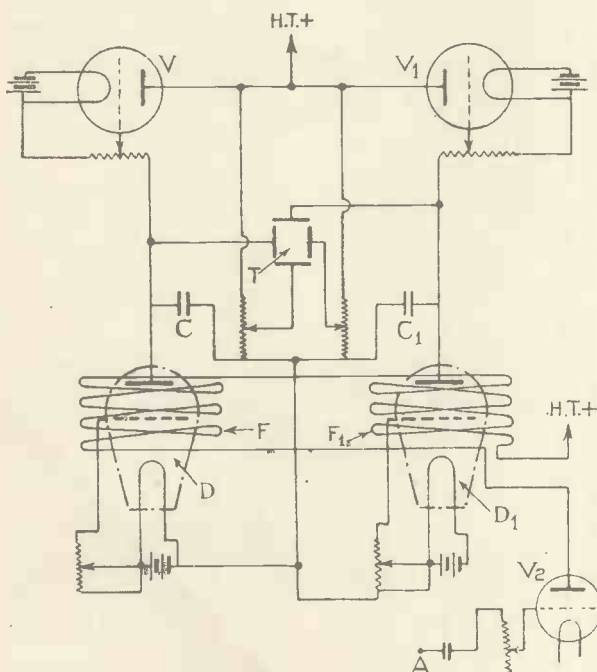

Saw-toothed oscillator. Patent No. 439,813.

fluorescent screen, a third electrostatic lens may be used to minimise the spread of the beam after it has passed through the point of concentration, and also to avoid "false"

diodes, are periodically discharged through two gas-filled tubes D, D_1 .

The moment at which each of the tubes D, D_1 is brought into action is determined by a synchronising

separate parts.—(*Radio Akt. D. S. Loewe.*)

(Patent No. 438,903.)

Mirror-drum system designed to minimise distortion due to curvature of the scanning lines.—(*J. L. Baird and Baird Television, Ltd.*)

(Patent No. 439,492.)

Cathode-ray tube in which the electron stream is modulated without changing the area of the spot of light created on the screen.—(*Marconi's Wireless Telegraph Co., Ltd.*)

(Patent No. 439,494.)

Prism system for natural-colour television.—(*W. S. Hewitt.*)

(Patent No. 439,579.)

Preparing lightly-printed films for use in "intermediate" systems of television.—(*A. G. D. West and Baird Television, Ltd.*)

(Patent No. 439,737.)

Method of increasing the normal size of television pictures by the use of electron optics.—(*L. Schiff.*)

(Patent No. 439,771.)

Television system in which certain identical images are presented to the observer more than once, in order to reduce "flicker."—(*J. L. Baird and Baird Television, Ltd.*)

(Patent No. 439,994.)

Means for "phasing" or synchronising the transmitter and receiver in cinema-film television by altering the position of the spot light on the fluorescent screen of a cathode-ray tube.—(*T. E. Bray and Baird Television, Ltd.*)

The information and illustrations on this page are given with permission of the Controller of H.M. Stationery Office.

APRIL, 1936

A Self-contained Five-metre Transmitter

For local working there is no need to use the lower frequency bands and increase congestion. G5ZJ suggests the use of a low power five-metre rig for distances up to 15 miles.

WHAT with the increasing number of stations on the 160-metre band, the terrific congestion caused by high-power phone and badly operated stations on 40 metres it would be a very good idea for as many G stations as possible to go down to 5 metres for purely local working.

On 40 metres in particular I have heard 100-watt stations working other stations less than 20 miles away. This is an absolute waste of power and not fair to the other stations on the band. The ultra-high frequencies seem to provide a ready solution to the problem. A simple transmitter can be constructed at minimum cost and can be used with a short indoor aerial in much the same way as the telephone.

The circuit chosen for my five-metre transmitter is of the very simplest type, merely a single valve in an ultra-audion circuit with low percentage modulation. The whole transmitter is built on one baseboard so that it is very compact and can be stowed away in any odd spot. For an oscillator valve the Tungram 0-15/400 was chosen as this gave a very high R.F. output. A single four-turn centre-tapped coil is connected across grid and anode with a grid condenser in one side. This grid condenser perhaps needs a little explanation. In the theoretical circuit two condensers in series are shown. Actually a condenser of .00025-mfd. capacity is required, but as 400/500 volts are applied to the anode it is advisable to have a fairly high volt-

age test condenser. So for that reason two .0005-mfd. condensers are connected in series giving a capacity of .00025-mfd. but with double the normal working voltage.

frequency choke is most important. The one chosen has an inductance of 5.6 micro-henries with a D.C. resistance of 1.3 ohms. A choke of this type can be home constructed and can consist of 30

As the tuning condensers are mounted on insulated brackets a wooden base-board and panel will not cause losses.

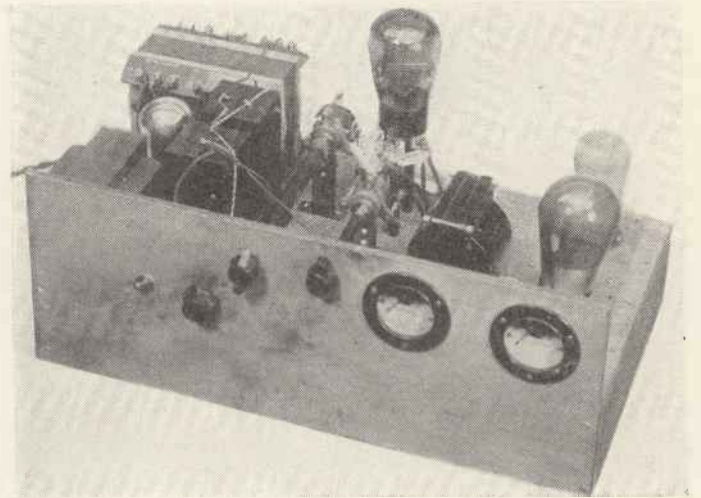

Similarly with the grid leak, instead of using a 125,000-ohm 1-watt, two .25-megohm leaks are connected in parallel so giving the required value but at 2 watts rating.

For tuning a 15-mmfd. condenser is connected across the four-turn coil, while another condenser of a similar type is in series with the aerial and the grid end of this coil. The high-fre-

turns of 26-gauge enamel-covered wire wound on a former about the size of the average pencil.

The high-potential side of this choke is connected to one side of a 1-1 transformer, the other side of the transformer being connected to maximum H.T. via the 200-milliamp. meter mounted on the panel.

For a power pack, arrangements must be made to obtain at least 400 volts at 100 milliamps. Of course, the same circuit can be used with low voltage, or even battery valves, but naturally the power pack will have to be adjusted so as to give the voltage required. If, for example, a PX4 valve were used a 250-volt power pack would do equally as well. On the other hand, with battery valves throughout 150 to 170 volts would be ample.

To obtain the normal output of 15 watts a power pack as suggested will have to be employed. Smoothing consists of one high-inductance 120-milliamp. choke plus 8-mfd. capacity. It is essential that the rectifying valve be of the indirectly-heated type otherwise too high a voltage will be applied to the amplifier section until these two valves warm up.

The microphone is connected via an input transformer and energising battery to two terminals mounted at the back of the chassis. These then feed into the grid of an AC/HL triode via

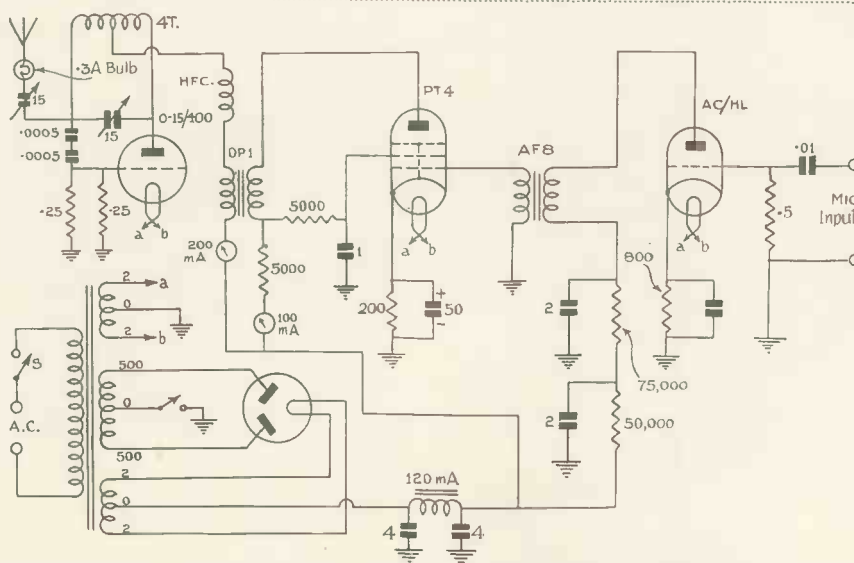

The indicating lamp in the aerial can be left in circuit as it does not cause any appreciable loss in radiation

15 Watts input on 5 Metres

an .01-mfd. condenser and 5-megohm leak. To obtain sufficient drive for

num supply and the 1-1 transformer. The screening voltage is kept down to

about 230 volts and is regulated by connecting 5,000 ohms between the screen and the low-potential side of the 5,000-ohm anode resistance. This is decoupled to earth by a 1-mfd. condenser.

A milliamp.-meter reading up to 100 milliamps is connected in the combined H.T. feed to the modulator. This then reads both anode and screen current. The bias resistance should be adjusted so that this reading is approximately 40/44 milliamps.

It should be observed that the H.T. feed to the AC/HL comes directly from the high voltage. This is because the high anode resistances would cause too great a voltage drop if it were taken from the 250 volts supply.

Two switches are required, one breaking the A.C. input to the primary of the mains transformer and the other in series with the centre tap of the H.T.



The oscillator section is mounted between the other two stages to prevent hum pick-up by the L.F. amplifier.

the PT4 an AF8 transformer is used for coupling. This makes quite sure that even with a low output microphone the A.C. output from the PT4 is kept up to the required 3.5 watts.

Owing to the simple nature of the amplifier, it is essential that decoupling be very thorough, so to that end the suggested 75,000 and 50,000-ohm resistances in the anode of the AC/HL should be used.

Bias for the modulator is obtained automatically by means of a cathode-resistance of 150 ohms. This is bypassed by a 50-mfd. condenser which although adequate can be increased to 250-mfd. if more bass is required.

The output of the modulator is fed into the secondary of the 1-1 transformer so coupling to the anode of the oscillator. As the PT4 only required 250 volts H.T. a resistance of 5,000 ohms is connected between the maxi-

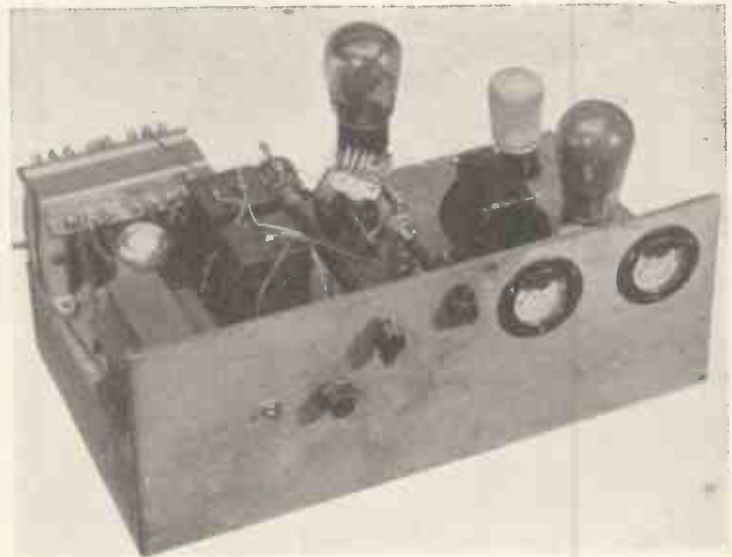

Two meters are required. One for reading the oscillator current and the other for checking the total current of the modulator.

COMPONENTS FOR

A SELF-CONTAINED FIVE-METRE TRANSMITTER

CHASSIS AND PANEL.

- 1—Chassis 18in. by 10in. by 3in. wood (Peto-Scott).
- 1—Panel 18in. by 7in., 3-ply (Peto-Scott).

COIL.

- 1—Type 1020 four-turn (Eddystone).

CONDENSERS, FIXED.

- 2—Type LSA 4-mfd. (Dubilier).
- 2—.0005-mfd. type 670 (Dubilier).
- 1—50-mfd. type 3003 (Dubilier).
- 1—.01-mfd. type tubular (Dubilier).
- 3—2-mfd. type BB (Dubilier).
- 1—1-mfd. type BB (Dubilier).

CONDENSERS, VARIABLE.

- 2—Type 900, .000015-mfd. (Eddystone).

CHOKE, HIGH-FREQUENCY.

- 1—Type 1011 (Eddystone).

CHOKE, LOW-FREQUENCY.

- 1—Type C32 (Savage).

HOLDERS, VALVE.

- 1—4-pin type chassis (Clix).
- 1—5-pin type chassis (Clix).
- 1—7-pin type chassis (Clix).
- 1—4-pin type SW21 (Bulgin).

METERS.

- 1—Type E66 100-m/a (Sifam).
- 1—Type E66 200-m/a (Sifam).

PLUGS, TERMINALS, ETC.

- 2—Terminals type B, marked input (Belling-Lee).
- 2—Knobs type K58 (Bulgin).

RESISTANCES, FIXED.

- 2—Type 1-watt, 250,000-ohms (Dubilier).
- 1—5-megohm type Ohmite (Graham Farish).
- 1—800-ohm. type Ohmite (Graham Farish).
- 1—75,000-ohm. type Ohmite (Graham Farish).
- 1—50,000-ohm. type Ohmite (Graham Farish).
- 1—5,000-ohm. type 3-watt (Graham Farish).
- 1—150-ohm. type 1-watt (Graham Farish).
- 1—5,000-ohm type PR9 (Bulgin).

SUNDRIES.

- 1—Extension shaft type EH5 (Bulgin).
- 1—Extension shaft type EH6 (Bulgin).
- 2—Insulated brackets type 1007 (Eddystone).

SWITCHES.

- 1—Type S91 (Bulgin).
- 1—Type S80 (Bulgin).

TRANSFORMER, L.F.

- 1—Type AF8 (Ferranti).

TRANSFORMER MAINS.

- 1—To specification giving 500-0-500, 2-0-2 at 2.5 amps. 2-0-2 at 4 amps.

TRANSFORMER, OUTPUT.

- 1—Type-OP1 (Ferranti).

VALVES.

- 1—AC/HL-met. (Mazda).
- 1—PT4 (Ferranti).
- 1—MU14 (Marconi).
- 1—015/400 (Tungsram).

winding and earth. The second switch is for "send" or "receive" and cuts the transmitter completely out of action when the receiver is in use.



The coil, choke and tuning condenser are all mounted close to the oscillator valve holder. This is most important.

The oscillator and speech amplifier are reasonably well screened, the top of the chassis being faced with zinc foil

APRIL, 1936

and the whole of the transmitter or oscillator section is on top of this foil, while the amplifier, with the exception of the two valves, is below.

By arranging the three units as shown, that is with the oscillator in the middle, there is practically no hum pick-up from the power pack, consequently the carrier is really T₉.

When operated normally the oscillator draws approximately 15-watts and puts approximately 7-watts of R.F. into the aerial. This is a very high degree of efficiency for this wavelength. The output from the modulator is sufficient to give quite a high percentage of modulation, but not 100 per cent. by any means. This is a distinct advantage for it prevents frequency modulation and keeps the transmitter reasonably selective.

As a guide to how the transmitter functions duplex working was carried out for a distance of five miles, when using a three-valve super-regen. receiver.

It is most important to see that the transmitter is within the five-metre band. The four-turn coil specified covers between 4 and 6 metres. This is approximately $\frac{3}{4}$ -in. diameter with a space of $\frac{3}{16}$ ths of an inch between turns. Wire is 18-gauge tinned copper.

The Aerial

The beginner should erect an aerial in the following way: Tap a length of wire 8 ft. 2 ins. long on to the rotor plate of the series aerial condenser. In the centre of this aerial fit a 6-volt .3-amp. bulb and then tune to obtain maximum light in the bulb. This is a

very simple way of telling when the transmitter is on five metres.

Another way is to tune a receiver to 20 metres, remove the aerial and tune the transmitter until an overtone is heard in the receiver. It does seem, however, that almost any length of aerial will put out a signal over a short distance. In fact, a 33-foot receiving aerial was found to be very satisfactory. An R7 report was obtained at a distance of a mile and a half by simply using a 4 $\frac{1}{2}$ -ft. brass rod mounted on a stand-off insulator. This report will surely indicate the value of a simple transmitter of this kind. It does not give maximum efficiency, but owing to its low cost, simple construction and operation, and capability of putting out a good signal it is really worth serious consideration.

Another British R.F. Pentode

At a meeting of the Surrey Radio Contact Club, G5GQ showed his version of the Jones Exciter Unit and 20-metre P.A. stage using the new Mullard PZ1-35 R.F. pentode.

This valve is particularly suitable for

As a modulated amplifier, an approximate carrier output of 12 watts can be obtained allowing for 100 per cent. modulation. In such circumstances the suppressor bias is minus 90, screened volts 200 positive, and grid bias 200 negative.

ing only 8 $\frac{1}{2}$ ins. x 6 ins., and uses the minimum of components.

Tungsram 0-15/400

An excellent valve for use on ultra high-frequencies and also for use as a sub-amplifier or frequency-doubler is the Tungsram 0-15/400. This valve is robustly constructed and can be considerably overloaded without impairing the emission. The anode is on the

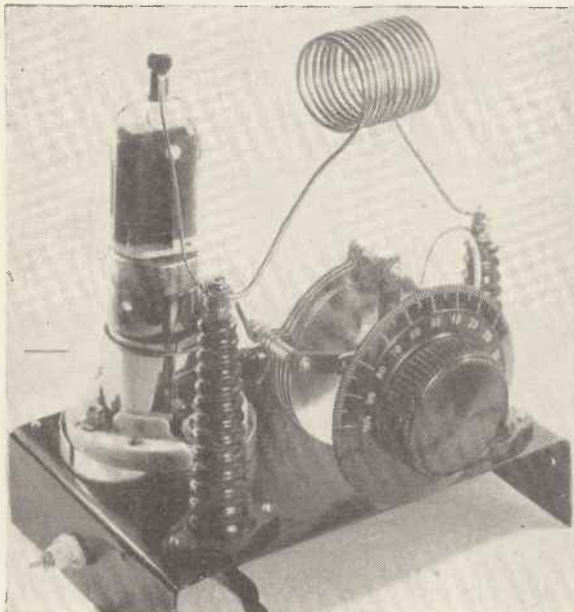

On the left is the 20-metre P.A. stage using the new Mullard R.F. pentode.

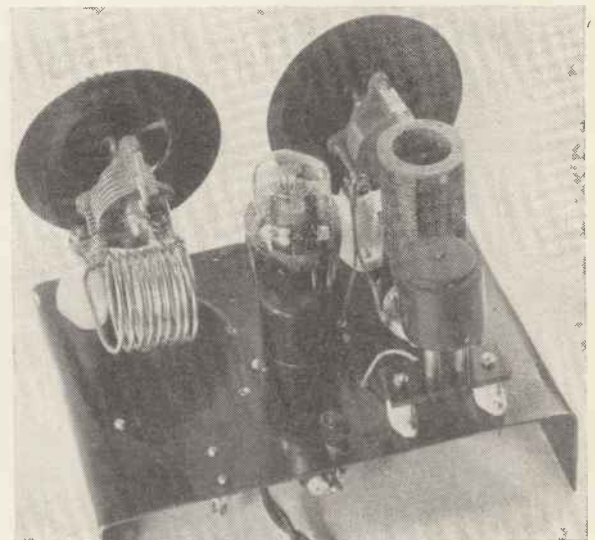

On the right is G5GQ's version of the Jones exciter unit. It uses a 53 valve as oscillator and doubler.

use in transmitters where space and weight are important. It is a very small 35-watt oscillator giving an output of over 50 watts at 50 metres. It requires low drive and neutralising is unnecessary. If necessary, crystal control can be applied direct to the control grid in which case an output of between 30 and 35 watts is available.

One of the most important features of this valve is that it can be used as a modulated amplifier, or modulated crystal control oscillator, by applying a modulating voltage in the suppressor grid, a suitable negative bias, of course, being employed.

The approximate characteristics are as follows:

- Filament voltage—4 volts.
- " current—2 amps.
- Total emission—800 milliamps.
- V/a.—1,000 volts.
- V/s.—100-300 volts.
- Maximum cathode current—110 m/a.

The Jones Exciter Unit shown by G5GQ consists of a 53-valve, one half used as a 40-metre crystal oscillator, and the other half as a doubler to 20 metres. This was then used to drive the R.F. pentode at 20 metres. This Exciter Unit is very compact, measur-

large side for a 15-watt oscillator, in fact it is larger than many 25-watt oscillators that we have tested. This coupled with a special filament accounts for the extreme efficiency of this valve.

It has a 4-volt 1-amp. filament, is rated to take a maximum anode voltage of 400 and consumes 35 m/a. with a bias of 35 volts. It has an amplification factor of 7 and an A.C. resistance of 1,400 ohms fitted with conventional four-pin base and is priced at '4s. For the beginner this valve is one of the most useful we have so far tested, while two in push-pull on 5 metres give more than the usual R.F. output.

Efficient Aerial Termination

The most important part of a transmitter is the coupling between P.A. and feeders. G2TA explains how the Universal Coupler ensures maximum transference of R.F.

OVER 50 per cent. of the efficiency of an amateur station is obtained by correctly matching the feeders to the P.A. tank coil. As the normal Zepp aerial varies in efficiency on different wavelengths according to the length of the top and feeders, it is not hard to realise that a transmitter with optimum radiation on 40 metres is not likely to be highly efficient on 20 or 10 metres without some means of compensating for variation in impedance.

Very few aerials plus feeder systems will resonate on all frequencies without the aid of some complicated tuning system at the P.A. end. The universal coupler is perhaps the most simple of these systems and increases the

with 14 or 16-gauge wire. Of course, low-loss construction must be employed otherwise much of the benefit is lost.

It will be realised that should the aerial be cut to length then the effect of the coupler will not be noticeable, but as the length is decreased and goes more out of resonance so the coupler improves the efficiency.

Adjustments are as follows: Disconnect the matching network from the transmitter at the tapping point A and tune the PA anode circuit for minimum current. Then adjust the tapping on L₁ to a point where resonance is likely to be obtained. In the case of the 160-metres band the whole 30 turns will have to be in circuit. For 80 metres only 15 turns are required, 8 for 40 and 5 for 20 metres.

Connect the output of the coupler to the tank coil, switch on the final amplifier and rotate C₁ until the current again drops to its original low value. This operation should be carried out very quickly to prevent damage to the valve. C₂ should then be adjusted to give maximum radiation after which C₁ should be readjusted. During these operations the P.A. tank condenser must not be touched. The exact position of the tapping A on the P.A. tank coil is not critical but it is better if this tap corresponds to an output termination of about 600 ohms.

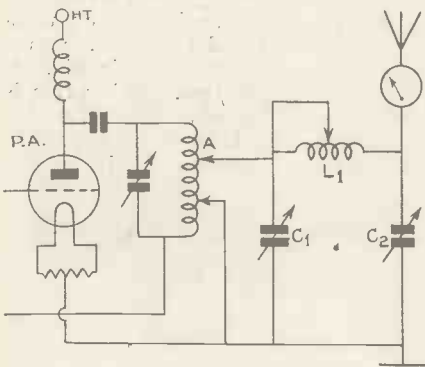

Fig. 1.—This system is only suitable for single wire feeds. It is most efficient on the 160-metre band.

efficiency of the conventional Zepp aerial by as much as 50 per cent.

The basic circuit shown in Fig. 1 is applicable only to single wire feeds or for 160-metre working. Two variable capacities and a tapped inductance are connected in a low-pass filter circuit, the normal aerial coil and series condenser being omitted. The input side of a filter is connected across the output of the transmitter and the output to the radiating system.

This coupler provides a marked increase in efficiency with a Marconi aerial on the 160-metre band, particularly when the top length is restricted to 66 feet.

Condenser Capacity

The two condensers C₁ and C₂ are of a fairly high maximum capacity of about .0033-mfd. while the inductance L₁ is 30 turns, 2½ ins. diameter and 5½ ins. in length tapped at every five turns. For the ordinary 10-watt top-band transmitter the condensers can be of the BCL type and the coil wound

Two-wire Circuits

On the higher-frequency bands where aerial termination is of greater importance the arrangement shown in Fig. 2 should be used. This circuit uses a split inductance, shown as L₁ and L₂, one inductance being in each leg of the feeder. C₁ and C₂ can both be standard BCL condensers but a split stator for C₂, earthing the rotor is quite satisfactory. Two ordinary variable condensers in series, with rotors earthed will work quite well; and, in fact, this arrangement will permit of finer adjustment of coupling to each feeder.

L₁ and L₂ are of equal inductance and these should be carefully made, otherwise it will put the feeders out of balance unless split stator condensers are used. The two taps should be spaced equidistant from the centre of the tank coil and if possible arranged for a termination of about 600 ohms. The circuit shown is exactly the same for either single-ended or push-pull oscillation.

The coupler should be built up on a metal panel so making a compact unit. The condensers and radiation meters can both be mounted on this

panel and the tapped inductances held in position by means of long stand-off insulators.

If two angle brackets are fitted at the end of the panel the unit can be screwed to the wall or to the side of the transmitter. The coupler shown in Fig. 2 is suitable for all wavebands even down to 5 metres, where a marked improvement in radiation will be noticed.

It is advisable purely as a precautionary measure to connect high-voltage test fixed condensers in series with the taps from the coupler so as to prevent D.C. voltage being fed into the aerial.

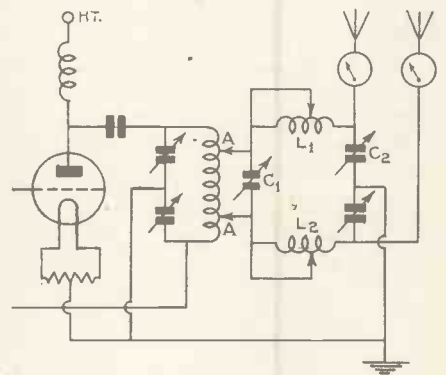

Fig. 2.—The more conventional circuit is suitable for all wave-bands. It can be adapted for use on 56 Mc. to great advantage.

This is particularly important with a single-wire feeder. With a 20-metre aerial cut exactly to crystal frequency the coupler will not be of any value, but if one aerial is to be used for all frequencies then a coupler is essential.

Surrey Radio Contact Club

On March 10 the monthly meeting of the Surrey Radio Contact Club was held at the Railway Bell Hotel, West Croydon. The meeting started with an informal dinner followed by a discussion on the proposed new station, which is to be operated by members, and other items of general interest. A lecture on the cathode-ray tube and its uses for modulation checking was given by Mr. Geoffrey Parr, of the Ediswan Co., who also demonstrated a modulated oscillator and a tube coupled to a five-metre transmitter lent by G5BY.

This society is for active transmitters and A.A. licence holders only. Those interested should write to the Secretary, Mr. E. C. Taylor, 35 Grant Road, Addiscombe.

Electron-coupled Frequency Meter

By A. C. Weston

This useful frequency meter is entirely self-contained including power pack and is suitable for both amateur and commercial wavebands. Frequency range is approximately 30-Mc. to 1.5-Mc.

SOME means of frequency measurement is essential in every well-equipped station. Very often during the course of a transmission it is necessary to check carrier frequency and the frequency used by other stations. Receiving stations would be lost with-

using several tuned circuits or a crystal bridge.

A battery-operated oscillator is only accurate if the voltages applied remain constant, although frequency drift is not so noticeable with an electron-coupled circuit using a screened grid valve.

Most amateurs realise, however, that the fewer L.T. and H.T. batteries in use the more efficient the station will be, so for that reason I built the frequency meter complete with power pack.

Cost would have been far too high if a conventional eliminator using mains transformer, valve and smoothing equipment, were used. So a new arrangement was evolved which brought down the cost to a few shillings. As can be seen from the theoretical circuit the power pack is of a particularly simple nature.

A 250-volt A.C. supply is fed into an H75 Westinghouse rectifier which then gives an output of about 250 volts at 10 m/a. when followed by a 1-mfd. condenser. So as to keep the voltage down the succeeding condenser was reduced in capacity from 1-mfd. to .1-mfd. which achieved the desired effect.

Smoothing and voltage dropping was obtained by means of a 50,000-ohms resistance by-passed by a .1-mfd. condenser so when the oscillator valve was functioning normally about 110 volts were applied to its anode.

The electron-coupled oscillator circuit is quite simple in design. A coil is connected across the grid-earth circuit. At a point about 1/5th from the earthy end, a tap is made and taken

to a cathode of the valve. The whole coil is then parallel-tuned with a condenser having a capacity of about 50-mmfd. This capacity just spreads the 1.7-mc. band over 180 degrees.

A .0003-mfd. grid condenser is used and joined up in the usual way with a 50,000-ohm resistance in parallel with it, the output from the oscillator being taken directly to H.T. positive through an anode impedance of 50,000 ohms.

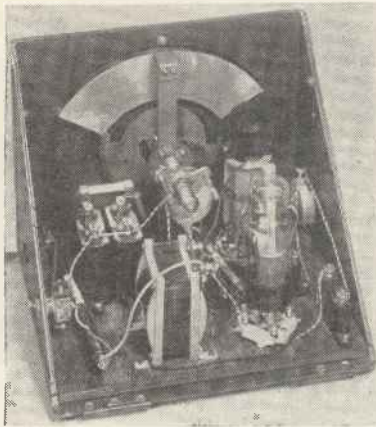

Owing to the simple power pack all the components for the meter can be housed in a case 8 ins. square.

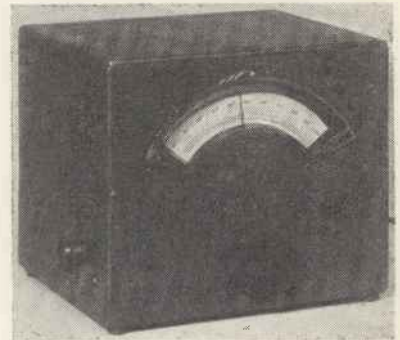

As the whole unit is completely screened a small aerial must be used. This need not exceed 6 ins. in length.

out some means of telling to which band and to what frequency the receiver is tuned. Reception of DX stations is greatly simplified if the section of the tuning scale to be covered can be narrowed down to two or three degrees by means of a frequency meter.

The introduction of the Dow electron coupled circuit made possible the design of a stable and highly efficient meter without going to the trouble of

The screened voltage, which is rather important, is obtained by means of a 100,000-ohm potentiometer across the full H.T. supply and this is varied to give maximum output from the oscillator. Variation in screened voltage will also cause the note to rise or fall. As this potentiometer has consistently to carry 2.5 milliamps. it is advisable to make sure that it is capable of carrying this load without possibility of breakdown. Also it must be of the type fitted with a dead spindle.

A.C. for the heater of the MS4B is obtained from a 4-volt 1-amp. filament transformer. This has two condensers of .01-mfd. capacity in series across the secondary to prevent ripple being set up and spoiling the oscillatory note. The whole unit is constructed to fit in a metal box so that if a small aerial is fitted to it there is only one source of radiation. Also this enables the meter to be used for checking the frequency of a transmitter at short range where an unscreened meter would probably go out of oscillation owing to overloading.

Four coils are required to tune between 10 and 200 metres. Coil 1 covering a frequency of 14,000 to 30,000 kc. consists of 3 1/4 turns with a cathode tap

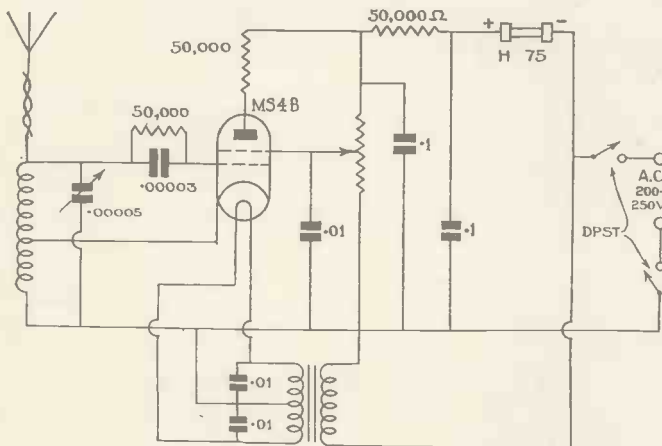

A 50,000-ohm resistance takes the place of the conventional smoothing choke. At the same time this resistance is used for voltage dropping. If a higher voltage is required the condenser following the rectifier should be increased to 2 mfd.

one complete turn from the earthy end. Coil 2 for 6,600 to 14,500 kc. requires $10\frac{1}{4}$ turns with a cathode tap two turns from the earthy end. Coil No. 3 for 3,250-6,800 kc. requires 31 turns with a cathode tap $3\frac{1}{2}$ turns from the earthy end. These three coils are all wound on a standard Eddystone slotted former with 20 s.w.g. enamel wire. The top band coil consists of 48 turns wound solenoid fashion without gaps between turns and a cathode tap nine turns from the earthy end. This should be constructed on a plain former and wound with 26-gauge enamel covered wire.

**COMPONENTS FOR
A.C. FREQUENCY METER**

- CABINET AND BASEBOARD.**
1—Metal cabinet type 1033 (Eddystone).
1—3-ply baseboard 9 ins. by 8 ins. (Peto-Scott).
- CONDENSERS, FIXED.**
3—.01-mfd. mica (T.C.C.).
2—2-mfd. type BB (Dubilier).
1—.0003-mfd. type M (T.C.C.).
- CONDENSERS, VARIABLE.**
1—Type 900, 40-m.mfd. (Eddystone).
- COILS.**
1—Set of four special frequency meter coils (Eddystone).
- DIAL, SLOW MOTION.**
1—Type 970W (Eddystone).
- HOLDER, VALVE.**
2—Type SW21 (Bulgin).
- PLUGS, TERMINALS, ETC.**
1—Plug top (Bulgin).
- RESISTANCES, FIXED.**
1—150,000-ohm. metallised (Dubilier).
2—50,000-ohm. type 1-watt (Dubilier).
- RECTIFIER.**
1—Type H75 (Westinghouse).
- RESISTANCE, VARIABLE.**
1—100,000-ohm. potentiometer (Erie).
- SWITCH.**
1—Type S126 (Bulgin).
- TRANSFORMER, MAINS.**
1—Filament transformer, 4-volt 1 amp. (Eddystone).
- SUNDRIES.**
1—Insulated bracket type 1007 (Eddystone).
1—Flexible coupler type 1009 (Eddystone).
- VALVE.**
1—MS4B clear bulb (Osram).

Calibration is not difficult. However, it is advisable to fix the meter in one position and calibrate with a given length of aerial, usually about 12 ins. of wire.

Pick-up on the receiver as many of the reliable commercial stations as possible. Note the dial readings, after which switch on the oscillator and adjust until a note is heard which corresponds with the dial reading on the receiver. Calibrations can then be transferred from the set to the meter.

Stations that can be recommended as keeping to their advertised frequencies are WSXK, W3XIL, W2XAD, W2XAF, any of the B.B.C. Empire stations and also Moscow and Madrid.

Calibration of the 160-metre coil will be simplified if the frequency register, published elsewhere in this issue, is consulted. The frequencies given have all been checked so that the stations mentioned can be tuned in and the readings transferred to the meter.

Screen-grid Valve Data

Little is known by the average amateur as to the characteristics of the screen-grid valve when operated as an R.F. amplifier. This article should prove of interest to those working on short-wave receiver designs.

THE general impression that a screen-grid valve has an infinite input resistance is erroneous, in so far as short-wave practice is concerned. The valve has a very decided effect on the gain per R.F. stage, which explains part of the loss in selectivity and gain in a R.F. amplifier operating at 20 metres, as an example. The minimum value of input resistance of a screen grid valve is the grid-to-plate capacitive reactance divided by half of the actual amplification gain.

If the inductance and resistance of a tuned circuit is known (plate circuit of the screen-grid valve), the value of impedance Z, can be calculated from:

$$Z_L = \frac{(2\pi fL)^2}{R}$$

Then Z_{EG} formed by the plate circuit in parallel to this tuned circuit can be

$$\text{found from } Z_{EG} = \frac{Z_L R_P}{R_P + Z_L}$$

where R_P is the plate resistance of the valve. From this the gain G can be calculated, $G = g \times Z_{EG}$, where g is the mutual conductance of the tube, $1,800 \times 10^{-6}$ ohms for a 6DC at normal voltages.

Taking a known value of G of 30 for a good 20 metre, 14 MC, R.F. amplifier, Z_{EG} can be found from

$$Z_{EG} = \frac{G}{g} = \frac{30}{1,800 \times 10^{-6}} = 16,640 \text{ ohms}$$

This low value explains part of the loss in selectivity and gain. The remainder can be explained by the input loss obtained as follows:

$$X_C = \frac{1}{.01 \times 10^{-12} \times 2\pi \times 14 \times 10^6} = 1,130,000 \text{ ohms, plate to grid capacitance reactance of a type 6D6 tube at 14 megacycles. This value divided by half of the stage gain of 30 gives}$$

$$\frac{1,130,000}{30} = 37,666 \text{ ohms grid input resistance. This is across the grid input tuned circuit which shows the need of regeneration in high-frequency R.F. amplifiers. Some feedback to give a "negative resistance" for counteracting the coil circuit losses and the valve loading effect should always be used, if possible. Regeneration improves both the selectivity and gain of an R.F. amplifier, at the expense of additional front panel controls in the receiver. Screened pentodes give a greater gain for a given input than a screen-grid valve and can be used to advantage in most receivers without much alteration to the circuit. The formula generally used to calculate the amount of gain per stage is as follows:}$$

Amplification factor of valve \times
dynamic resistance of H.F. coupling
dynamic resistance of H.F. coupling
+ valve impedance.

For simplicity this can be written,

$$\text{stage gain} = m \times \frac{r_o}{r_o - r_a}$$

where m equals the amplification factor of the valve

r_o equals dynamic resistance of coupling and
 r_a equals impedance of valve.

So the expression $\frac{r_o}{r_o - r_a}$ represents

the fraction of a valve amplification factor which is usefully employed.

The dynamic resistance depends upon losses in the H.F. coil and condenser and the accuracy with which the circuit is tuned to resonance with the incoming signal. Average tuned couplings have a dynamic resistance of about 100,000 ohms, while with super-efficient coils the figure may rise to 250,000 ohms or even more if reaction is employed.

Hollywood and Wythall Radio Society.

It is proposed to start a Radio Society in the Hollywood district of Birmingham and interested readers should write to I. Quilton, 2AGV, of Jesmond-dene, Shawhurst Lane, Hollywood, near Birmingham.

Blackpool Short-wave Club.

A short-wave club has been formed in Blackpool and it is hoped to have a live Society going in the near future. Will interested readers write to the Secretary, Mr. Eric Sutcliffe, The Welbeck Hotel, North Promenade, Blackpool.

Cardiff & District Short-wave Club.

The last two meetings of the Society, held at Barry's Hotel, St. Mary Street, Cardiff, were very successful there being 36 and 27 members present respectively. Morse practice was conducted by Mr. W. Sutton and Mr. R. Mills and several members were able to achieve quite high speeds. Several television lectures are to be given at a later date and those interested should write to the Hon. Sec., H. H. Phillips, 132 Clare Road, Cardiff. Amongst members are G5BI, 5XV, 2NG, and 2ABI.

FARNSWORTH DEMONSTRATES 1000-WATT MULTIPACTOR TUBE

By George H. Eckhardt.

MR. PHILO T. FARNSWORTH, vice-president of Farnsworth Television Incorporated, of Philadelphia and San Francisco, recently demonstrated before a meeting of the Institute of Radio Engineers, in New York City, a number of his new Multipactor tubes. The efficiency, simplicity, and comparatively low cost of these tubes, Mr. Farnsworth stated, would go far towards making the opening of television broadcasting stations possible. He also suggested a wide use for these tubes in aeroplanes for transmission of sound, since here simplicity and lightness were paramount.

By taking advantage of the secondary emission of electrons, an effect hitherto studiously avoided and considered detrimental by the designers of radio valves, Mr. Farnsworth has evolved a new tube which operates with greatly increased efficiency, and eliminates many of the disadvantages of tubes now used for broadcasting and receiving.

This hitherto avoided effect resulted in decreasing the output and efficiency in previously designed tubes—and as a matter of fact—engineers were hard put to find ways of eliminating secondary emission. As a result the elements of many of the present tubes

are purposely coated with graphite or carbonised so that secondary electrons will not be given off when the primary electrons from their hot cathodes strike the surfaces of their elements.

worth, he not only explained how these desirable results are obtained, but also demonstrated the actual operation of his Multipactor tube as oscillator, and amplifier for broadcasting purposes.



This photograph shows a $\frac{1}{2}$ -kilowatt Multipactor tube for use as an oscillator.

Mr. Farnsworth, in his new tube, ingeniously takes advantage of what before was considered a disadvantage, and utilises secondary emissions to achieve greater efficiency and higher power output from tubes of a given size.

In the tubes shown by Mr. Farns-

Probably the most interesting feature to the radio engineer is that in some of the designs of Farnsworth Multipactor tubes no filament, or heated cathode, of any type is used or needed. The advantage of this will be realised when it is remembered that the life of ordinary valves now in use ends when the filament burns out. Therefore, if these "filamentless" Farnsworth Multipactor tubes are operated within their ratings, there appears to be no good reason why they should not last indefinitely.

The basic theory upon which these Multipactor tubes work is extremely simple, and the manner in which it was used is quite ingenious.

In the "filamentless" Farnsworth tubes the few stray electrons which are always present due to photo-electric effects are bombarded against a surface especially prepared to have the best possible secondary emitting properties. As a result these original electrons on striking this surface cause the emission of many times more electrons, than were in the original bombardment. This procedure is repeated many times until the desired "electron amplification" is reached.

However, due to the special design



The Farnsworth Multipactor tube for amplification.

of the Farnsworth Multipactor tube, this process is controlled with great precision. This "electron amplification" builds up in such extremely short time intervals—that—if allowed to go unchecked—the tremendous current produced would fuse the elements of the tube.

By the application of his Multipactor principle Mr. Farnsworth also showed how the output and efficiency of his own filament type tube resulted in greater output current and greater amplification than would be at all possible without taking advantage of secondary emissions.

The Farnsworth Multipactor tubes may be used as amplifiers, oscillators, frequency multiplier, detectors, in short—wherever filament tubes are used to-day. An especially outstanding feature is the practically "noiseless" amplification that has been obtained with the Farnsworth Multipactor tubes. These tubes are especially suited to the amplification of high frequencies, particularly in the high fidelity of amplification of the extremely feeble initial currents encountered in television.



The Farnsworth Multipactor tube in use as a power amplifier driven by a smaller tube used as an oscillator.

DR. ZWORYKIN VISITS BERLIN

Professor Zworykin, head of the Radio Corporation of America's Laboratories for Electronic Research, recently visited the laboratories of the Telefunken Company in Berlin, and also gave a lecture at the "Technische Hochschule" in Charlottenburg. All reference to television had seemingly been "censured" by the German authorities, but it is generally understood that the Germans, and especially Telefunken, are very much further on in the development of the so-called "Electric Eye" than one supposes.

Amateurs in Sheffield.

Readers in the Sheffield district should get in touch with the Secretary of the local society, G2JY, Mr. A. Pemberton, 57 Tillotson Road, Sheffield.

Meetings are held periodically in which all of the local amateurs attend. Morse practice for beginners is given while arrangements are being made for slow morse tests on the 1.7 mc. band.

GERMANY'S TELEVISION TELEPHONE

From our German Correspondent.

VISITORS arriving in Leipzig for the opening of the Spring Fair on Sunday, March 1, were handed red hand-bills by Post Office officials in uniform at the Central Station. These bore the following legend in four languages: "Please use the television 'phones at the Post Office on the Augustusplatz and in Exhibition Hall No. 8 of the fair-grounds."

That morning the German Minister of Posts, Herr von Eltz-Rübenach, officially inaugurated what can be termed with safety the world's first high-definition long distance television-telephone. Communication is possible between two public call-offices in each of the respective towns. In Berlin one is on the Potsdamer Platz, the other at a busy corner in the West End. In Leipzig the Central Post Office on the Augustusplatz has been fitted with a television-telephone and the Post Office on the Fair Grounds. The service remained open until March 7, and was then discontinued until the end of the month for tests. A 3-minute communication costs R.M. 3.50, a sum which includes notification of a desired person at the other end of the line.

The co-axial cable which has been

laid between the two towns is of German make. It can handle a frequency band of up to two million cycles. At the present moment 180 line-definition and 25 frames-per-second are employed. This is amply sufficient to give an excellent head-and-shoulder image of the persons speaking to each other. It is not thought that definition will be increased for this service. On the other hand, the cable gives facilities for transmitting television modulation of pictures with a definition of up to 320 lines and 25 frames-per-second (2 million cycles). By speaking from Berlin to Leipzig and back to Berlin, German Post Office engineers were able to successfully cover a distance of 250 miles (395 kilometres). The actual distance between Berlin and Leipzig is roughly 100 miles, but the cable, no doubt, follows another than the railway route.

To use the television-telephone one

sits in a comfortable armchair of the "grandfather" variety, in a white-walled cabin, and the picture of the person at the other end appears in an aperture immediately above the bright scanning light. Armchairs have been used which the attendants can raise or lower at will to adapt them to the size of a given person in order to ensure the best viewing position.

Mechanical scanning is employed throughout, the apparatus in Berlin has been constructed in the German Post Office laboratories, and that in Leipzig has been supplied by the Fernseh A.G.

Your correspondent was given facilities to see and speak from Leipzig to Berlin. Recognition of friends was immediate, and he could even discern the wedding ring on the hand holding the receiver.

Germany's First Television-Telephone

The German Post Office demonstrated two low-definition two-way television some years ago at a Radio Exhibition. The apparatus can now be seen in the "Deutsche Museum" in Munich. At the time, 30 line-definition was employed. If your correspondent remembers rightly the first demonstration took place in 1928. The apparatus was placed in the museum in 1929.

READ TELEVISION
& SHORT-WAVE WORLD
REGULARLY

Scannings and Reflections

By THE LOOKER

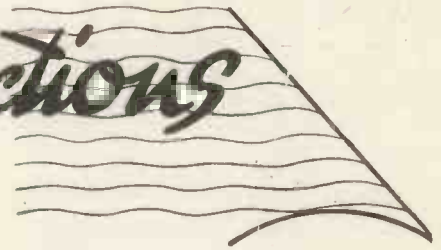

Implosion

I WOULD be reluctant to think that my remarks under the above heading last month could in any way be construed as a reflection on the manufacturers of cathode-ray tubes. All I intended was to draw attention to a risk which is never completely absent from vacuum glass apparatus. I am reliably informed that every precaution is taken to ensure that cathode-ray tubes shall be as robust in service as possible, and the risk of breakage is no more than in the case of, say, the larger lamps. Every bulb is tested to several atmospheres pressure before being used, a strain which is far greater than that which it is called on to withstand in use. But as there is a risk of collapse, however slight or serious it may be, the coming television receiver will, I am confident, have the top of the cabinet—that is, the viewing space—enclosed with Triplex glass, very thin but very strong. At the moment, I know of at least two distinct makes that will be so protected.

The New Receivers

Many radio manufacturers are working more or less secretly on the design and production of television receivers and some, I know, have already accumulated a stock. The firms will not readily talk for publication although some of them are willing to tell me in confidence something of their plans and from what they say I think we can look forward with every confidence to some highly efficient receivers being at the disposal of the public by the time there is a regular television service. They will be experimental only so far as all scientific apparatus is experimental; that is, as everyday use suggests improvements, these will, in the ordinary course, be adopted. Our information leads us to believe that the manufacturers are waiting to put on the market some really good receivers giving a picture from 11 to 14 ins. wide and about 10 ins. deep.

The radio receiver may be of the super-het type, in which the first detector valve is made to answer for both sound and vision reception. There will be separate oscillators to deal with the two types of signal, but probably the intermediate-frequency amplifiers, second detector and low-frequency amplifiers will, in some models, be common to both sound and vision. And there may be even a common ganged condenser tuning both the sound and vision oscillators at the same time so as to simplify the tuning considerably, but there will be separate control knobs, of course, for bringing in the picture. It is too early to say much about cost, but from £60 to £70 is, I think, a good guess.

J. L. Baird at Leeds

John L. Baird was the guest of honour at the first annual dinner of the Yorkshire Television Association held in Leeds early in March. Altogether there were about a hundred present, including the Lord Mayor of Leeds and other local dignitaries. In reply to the toast of his health, proposed by Prof. E. L. E. Wheatcroft (Vice-President of the Association), Mr. Baird indulged in some reminiscences and recalled that it was in Leeds that the idea of forming the Television Society was first mooted—nine years ago, on the occasion of the meeting of the British Association in that city. The Secretary of the Association announced that it had been decided to build a television transmitter to be operated on the 10-metre band, for the benefit of their members. Our contributor, Mr. J. H. Reyner, is consulting engineer to the Yorkshire Television Association.

Phone-television for Dublin

Our Irish readers will be interested to learn that the phone-television apparatus recently demonstrated at Selfridges, London, and described in this issue, is at the time of writing in operation at Clerys, Dublin, and will remain so until March 28.

A Co-axial Cable for Leeds

A decision has been made by the Post Office authorities to take a branch from the London-Birmingham high-frequency cable to serve Leeds. Primarily, of course, this is intended for telephonic communication, but there is the possibility, should the cable be capable of carrying the high frequencies necessary, that it will be used for television.

Transport of Artists

Elaborate arrangements are being made by the B.B.C. for the transport of artists from Broadcasting House to the Alexandra Palace and from Wood Green Underground Station to the Palace. There will be a regular service of cars, but at the moment I hear that it is not proposed to have a specially fitted coach in which artists could make part of their preparations *en route*.

London's Television Staff

The B.B.C. staff at the Palace will number about fifty, the first to start duty being the engineers who will move over on the first of April, the production staff and executive following a month later. For the thirteen posts advertised by the B.B.C. on the productions staff at the Alexandra Palace a total of 2,418 applications were received and these were divided up as follows: Music Director, 89; Stage Manager, 166; Producer, 110; Assistant Producer, 85; Producer of Special Programmes, 26; Film Assistant, 101; Artist Booking Assistant, 131; Announcer (male), 588; Announcer (female), 677; Hostess, 445. This list only includes ten positions; actually, however, there are to be three producers and two stage managers. By far the largest number of applications were for the post of Lady Announcer.

Dr. Zworykin in Europe

Dr. Zworykin, laboratory director of the Radio-Corporation of America, has been touring Europe and gave a

MORE SCANNINGS AND REFLECTIONS

lecture on electron image tubes at the Paris Sorbonne, on March 10, before the "Societe des Radioelectriciens."

French Television Programmes

The hours of television transmissions from Paris have been changed since March 1 and are now as follows:—

Day.	Eiffel Tower	Paris P.T.T.
Monday	16.00-16.30	16.30-17.00
Tuesday	16.30-17.00	16.00-16.30
Wednesday	16.00-16.30	16.30-17.00
Thursday	16.00-16.30	16.30-17.00
Friday	16.30-17.00	16.00-16.30
Saturday	16.30-17.00	16.00-16.30

Television Studio at Broadcasting House

The co-axial cable that is being laid between Broadcasting House and the Alexandra Palace will make it possible to relay from the B.B.C. headquarters any sound programme to be transmitted upon the ultra-short waves. The advantages will be greatly improved quality and the availability of another transmitter during the times when no television programmes are in progress. This cable is largely an experiment on the part of the Post Office and actually no definite plans have been made for its use, which obviously will depend upon the results obtained. I foresee that if it should prove an entire success the need for the Palace for use as anything but a transmitting station would not exist, as all programmes could be relayed from Broadcasting House.

The Television Aerial Mast

The foundations on the top of one of the existing towers of the Palace are now complete and a start with the erection of the mast will have been made by the time these notes are in print. The mast has been completed in separate sections and there now only remains erection which I expect will take about a month. It will be remembered from illustrations already published in TELEVISION AND SHORT-WAVE WORLD, that the four legs of the mast are to rest upon the four corners of the tower and that about half-way up the mast becomes octagonal in shape. The mast will be self-supporting without any stays.

An Arena

Provision is being made in the grounds of the Palace for outdoor

displays, as, for example, of cars, aeroplanes, etc. There will be a sort of arena screened from the public gaze.

Television to Increase Radio Trade's Business

In the course of an address "Television Past and Present" delivered at a meeting of the Manchester Radio Trade's Luncheon Club, Mr. J. L. Baird touched upon the hostility to the advance of television in certain sections of the radio trade, based on the misapprehension that television would affect their business. This, said Mr. Baird, was a foolish attitude. Television would increase their business, opening a new and, he hoped, profitable territory for everyone connected with the radio industry. This point of view was, he was glad to say, now becoming quite general in the trade among those who had investigated the subject. "We are going to see television—perhaps not this year or next, or even the year after that—become a more permanent factor in public life than even the cinema or sound broadcast."

Installing the Plant

Installation of transmitting gear, generators, etc., at the Palace is to begin in the first week of April. Although the B.B.C. staff will be in entire charge, both the Baird and E.M.I. Companies will, for the time being, provide their own maintenance engineers.

News from New York

According to the plans announced by David Sarnoff, President of the Radio Corporation of America, the first field tests of television by R.C.A. will begin shortly. The Corporation's annual report emphasises that this experimental test does not mean that a regular television service is at hand. It is no more than an essential pioneering stage to estimate and define its possibilities under actual working conditions. The television transmitter will be on the Empire State Building, in New York City, and test receivers will be operated by technical personnel of the R.C.A. organisation throughout this area.

The transmitter will be connected by radio with the television studio, now nearing completion in the N.B.C. plant, R.C.A. building, in Radio City, New York. As the work goes on, it may be necessary to return to the laboratory, from time to time, to seek the solution to practical problems encountered in the field, but the management is confident that the R.C.A. experimental television project will continue to progress at an encouraging rate.

The Report

For some time I have been awaiting the publication of the report of the Broadcasting Committee which, over quite a large part of 1935, was receiving evidence and considering what recommendations it should make with regard to the future of the British broadcasting service, but I have been disappointed as the months went by that the Committee has permitted so much delay in the proper completion of its labours. Now, at last, the report is here—and my disappointment is the greater. The report is a thin and rather profitless compilation into which but little of the combined wisdom of the seventy-nine witnesses examined by the Committee has been allowed to percolate. In things that matter, Broadcasting is hardly affected by the Committee's conclusions.

The impression I get from reading the report is that the Committee found the B.B.C. to be an almost perfect machine and in the shoals of evidence that wellnigh engulfed the members of the Committee they discovered only the tiniest suggestions of improvement.

The B.B.C.'s charter is to be renewed for a further term of ten years and, apart from questions of detail to which reference is made in the summary of the Committee's recommendations, printed elsewhere in this issue, there is little more to be said, although relay subscribers will be interested to know that their systems are to pass over to the Post Office and their control to the B.B.C.

The ten-shilling licence fee is retained. Seventy-five per cent. of it is to be paid to the B.B.C. and a hint is given that for the financing of television even a greater percentage may have to be allocated.

I repeat—a disappointing report which leaves out much and does nothing for television.

Read
**Television and
Short-wave World**
Regularly

Making High-voltage Condensers

By John Lucas, 2BDN

TUNING condensers for the P.A. circuit in a high-power transmitter are always a problem. Even if they are obtainable ready built the price is usually about 50s., more than most amateurs care to pay. It is surprising that in view of the demand for this type of condenser that more of them are not home-built.

The writer has just built a .0002-mfd. condenser from standard plates,

points marked A on the stator plate must be smoothed off until the gap between the centre spindle and the nearest edge of the plate equals the gap between the rotor plates.

The 2B.A. brass rod is locked in position on to the ebonite end piece by two nuts either side. Eleven small washers are put on before the first plate, the remainder of the plates being placed in position with eight spacing washers between each. After the final plate a further 19 washers are fitted, then the plates can be locked in position.

A bush should be let into the ebonite and the centre rod fixed in position so there is about 2 ins. of the screwed portion protruding through the ebonite. Four of the large washers separate the first moving plate from the ebonite, after which a further 19 plates are fixed in position again with eight washers between each plate. Following the final plate a further four washers are fixed and locked in position. The locking nuts for the moving plates should be left fairly slack so that the whole of the centre spindle can be adjusted to bring the moving plates in the exact centre of the fixed plates

In view of the length of this condenser it is surprising that there is no whip, but so far it has proved entirely satisfactory and free from arc-over even with the heaviest modulation.

Another condenser which is very suitable for series work where there is likely to be a high potential is shown in the second illustration. This perhaps does not look very elegant, or conventional, but it is cheap to make and should not take more than half-an-hour to knock up.

Buy three aluminium or brass plates of 16-gauge 10 ins. by 8 ins. with a 1-in. lip. These are mounted on to Raymart S.S. type midget stand-off insulators. With a gap of $1\frac{3}{4}$ ins. between the outside two plates, the maximum capacity is .00025-mfd.

The centre plate which acts as the rotor, is, in the original model, adjusted by hand simply by pulling the plate into position by means of a stand-off

insulator. But it does not entail much ingenuity to fix a handle on it and arrange matters so that it can move in a

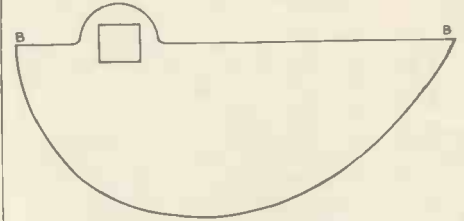

It is essential that the points of the plate be rubbed off at points marked B.

runner. The size of the condenser is not so great that it cannot be embodied in most amateur hook-ups. On the other hand smaller plates and a smaller gap would give the same capacity if a lower voltage test could be tolerated.

Another way of obtaining a high capacity plus wide gap is to make the

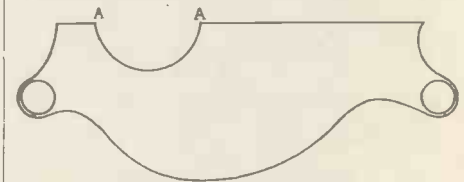

The points marked A should be smoothed round so that the gap between A and the rotor spindle is equal to 8 spacing washers.

rotor plate in the form of a box. Obtain two sheets of brass aluminium or zinc, both fitted with a 1-in. lip. Invert one plate so that both can be bolted together with open ends.

In this way a rotor plate can be made very firm without decreasing the size of the gap between rotor and stator. It is no difficult matter to fix a small insulated handle on to the rotor plate for fine adjustment. It is not a practical idea to try and support the top of the rotor plate for any insulator with the exception of ceramic substances will cause losses. This means that the rotor plate must always be self supporting.

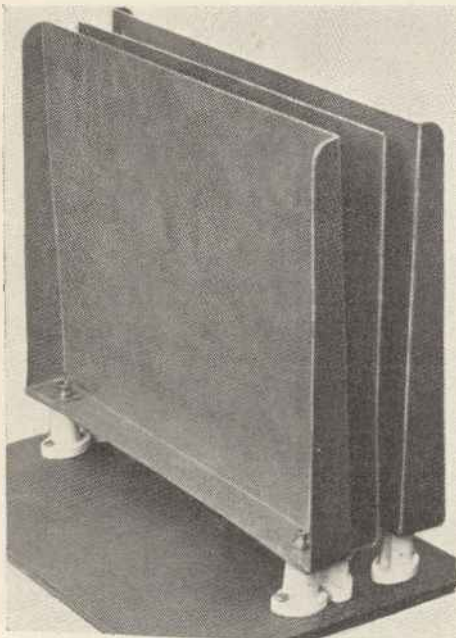

With this type of condenser the rotor plate is adjusted by hand. This is not so difficult as it may appear.

which will, if necessary, stand up to about 4,000 volts without flash-over. The cost of this condenser is less than 2s.

The photograph shows how the condenser is made up in quite a conventional way. Two ebonite end pieces are required, each 5 ins. wide by $3\frac{1}{2}$ ins. by $\frac{1}{4}$ in. fitted with brass brackets 5 in. by $\frac{3}{4}$ in. by $\frac{3}{4}$ in.

The stator plates are mounted on two 2B.A. brass rods 15 ins. long, while the rotor plates are on $\frac{1}{4}$ -in. square brass rod 17 ins. long. The squared rod has to be screwed at one end for a distance of 2 ins. on to which is fitted a control knob. On the other end of this rod a screwed section of about $\frac{1}{2}$ in. is required so that the plates can be locked in position.

No Sharp Edges

Twenty rotor plates and 19 stator plates are required, but before these are fixed into position, the sharp corners must be rubbed off. The two

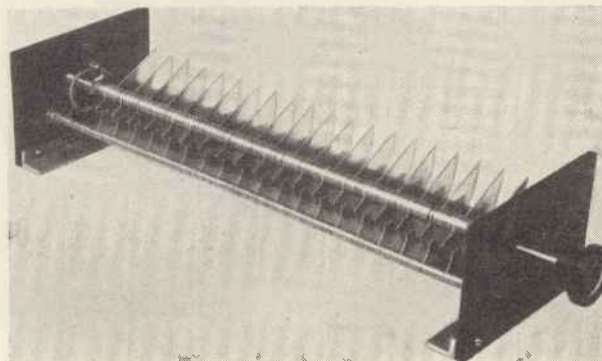

A condenser of this kind is more or less conventional and even though it consists of a 15 in. rotor there is no trace of whip. It can be made split stator quite easily.

A U.H.F. 112-28 Mc. Super-heterodyne

We have pleasure in presenting a sensitive receiver for the higher-frequency bands. The eight-valve circuit chosen is one that has been well tried and is being used by the designer, KENNETH JOWERS, for 5 and 10-metre work.

LAST season interest in ultra-high frequency working was fairly keen, but only to the extent that apparatus was built out of spare parts. No real effort was made to design sensitive receivers or stabilised transmitters, so consequently DX was limi-

were an improvement, but two troubles were introduced that could not be overcome. First, the lack of sensitivity on weak signals and, second, doubtful oscillation below 10 metres.

At about this time the British amateurs started to think of crystal

during last summer, but with only indifferent results owing to the lack of good receivers. Two super-regens were in general use, but except for stations located less than five miles away nothing much was heard.

The first super-het appeared after the first tests to be a great success, and it was not for some months and after exhaustive tests that it was discarded as useless. I experienced the same trouble as the Americans: lack of sensitivity on weak signals.

All types of multiple valves were tried in all kinds of hook-ups but with little success. Ultimately, after going into the matter with one of the leading American amateurs who had done so much on this band, I decided to go in for a separate detector and oscillator.

From the very beginning this was a great improvement, although below the standard required. The first circuit tried used a standard screen-grid with grid injection through a small coupling condenser. The final circuit chosen, which appeared to overcome the main difficulty of lack of sensitivity when it was most wanted, consisted of a high-frequency pentode of the low-capacity type and a low-impedance triode as a separate oscillator. This arrangement worked well beyond expectations, but only if the grid of the oscillator was connected directly to the suppressor grid of the pentode.

A small coupling condenser brought back the old troubles without any advantages, so several other types of oscillator circuit were then tested.

It really is surprising just how im-

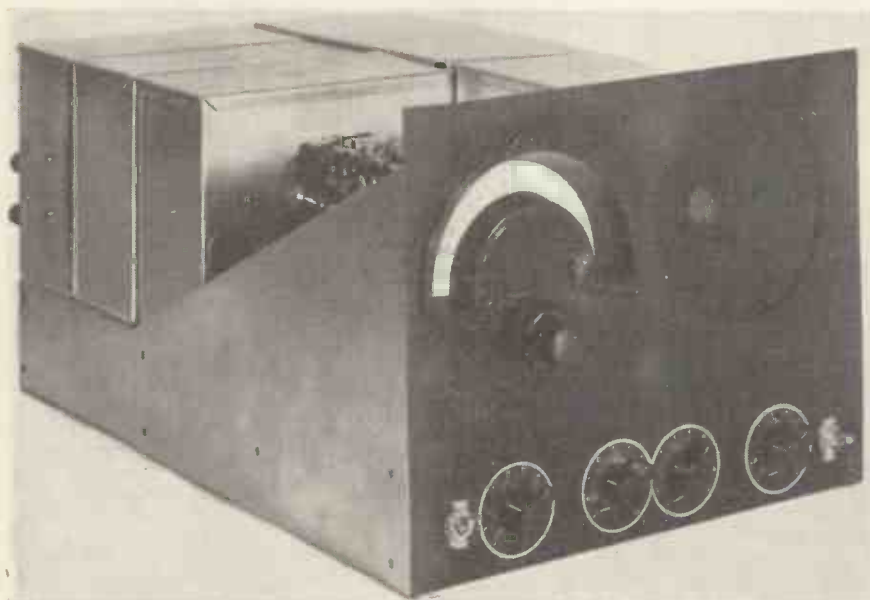

The chassis is narrow and long so as to take up as little space as possible. The general construction is of very advanced design.

ted, in the majority of cases, to a mile or so.

In America the 5-metre band rather took the place of the 40 and 160-metre bands for local working owing to the lack of QRM. Some two or three years ago the Americans experimented with the super-regenerative type of receiver on the score of simplicity and to the lack of good stable signals. Actually the broad tuning of the super-regen. is a help when receiving a modulated oscillator.

The introduction of Tri-tet and even crystal-controlled gear made it possible for the receiving end to be improved, which meant the use of super-het receivers.

First of all the autodyne was tried with poor results. Actually the only advantage of the early super-het was low noise level. It was then discovered that the autodyne was not sensitive to weak signals even though it gave greater output on the local and more powerful stations. Heptodes

control and stabilised transmitters for 5 metres with the result that several stations achieved good results over long distances. I was very active

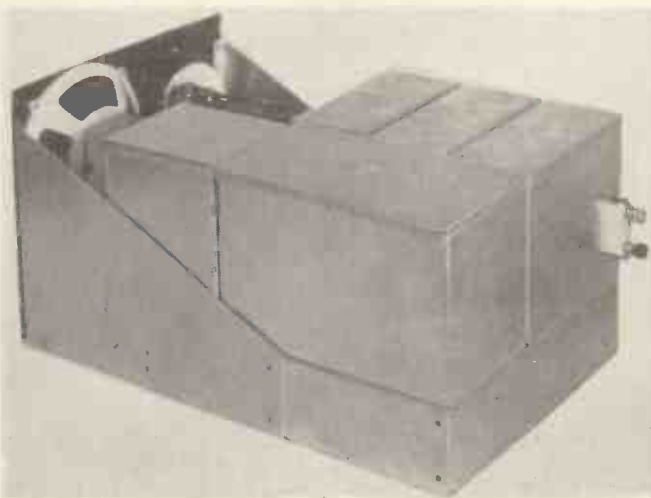

As the entire receiver is completely screened duplex working is made quite simple. When used in conjunction with the transmitter described elsewhere in the issue duplex working was carried out over a distance of 26 miles.

APRIL, 1936

portant this point can be. All of the usual methods were about the same in efficiency except the Dow electron-coupled oscillator.

This was vastly superior to all other methods on *weak signals*, although on the local stations no improvement was noticed. Another point in connection with the oscillator was the use of an air-spaced grid condenser and the value of grid leak. The air-spaced condenser reduced the noise level by an appreciable amount, while any other value of leak other than the one specified caused a decrease in sensitivity. This, of course, may only apply to the particular valve used.

As the receiver was wanted for duplex working at short range re-radiation had to be cut out. This is a very important point in congested areas. If the 5-metre band is to be used for local work a pre-H.F. stage must be used both with super-het and super-regen receivers.

The addition of the H.F. stage made no noticeable difference to the stage gain although the selectivity was improved for duplex working.

Regeneration on the H.F. stage caused what appeared to be a small H.F. gain in the first stage. This was not measured, but signals certainly came up in strength while noise level went down with a run.

So far, the first three stages had been designed to my satisfaction for a sensitive super-het circuit had been obtained. The I.F. amplifiers did not cause much trouble. There were only two alternatives. The first R.C. coupling and second normal I.F. transformers. I had already ruled out tuned anode as being of little use in a receiver of this type.

To obtain the required gain with R.C.

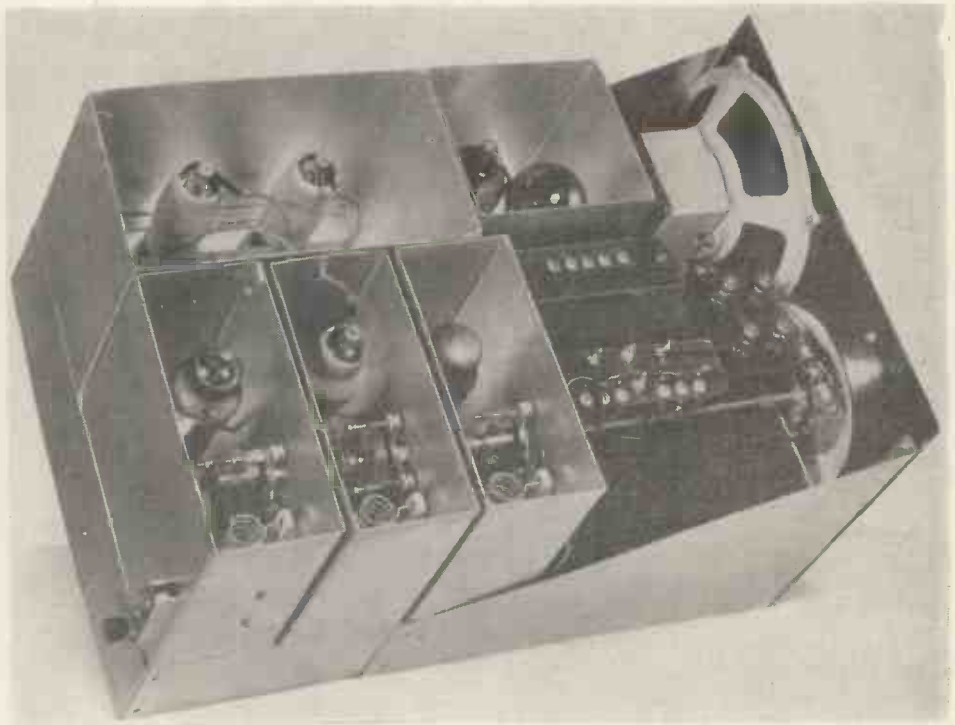

The power pack is very compact but is easy to wire if the panel is fitted last. See that the extension spindle for the tuning condensers does not touch the metal rectifier.

coupling meant three stages—rather an expense not really warranted. In any case, after experimenting with various receivers I realised that many amateurs who generally economise on screening would have trouble in holding down three efficient stages of I.F.

So I.F. transformers were wound up to a frequency of 3,000 kc. and mounted in small metal boxes. These proved quite satisfactory except that they were too selective. As most of the stations heard were wobbling all over the place the tuning had to be flattened out.

This was soon done by the addition

of resistances across both primary and secondary. The gain went down a little so the frequency was decreased to compensate.

The Eddystone I.F. transformer unit was tried, for this had been designed for 5-metre super-hets. It proved very suitable for this particular receiver. This unit is already screened, so saving a most unpleasant job.

The second detector stage causes more trouble than would at first sight be imagined. No triode valve gave sufficient gain as anode-bend rectifiers. Leaky-grid rectification caused poor

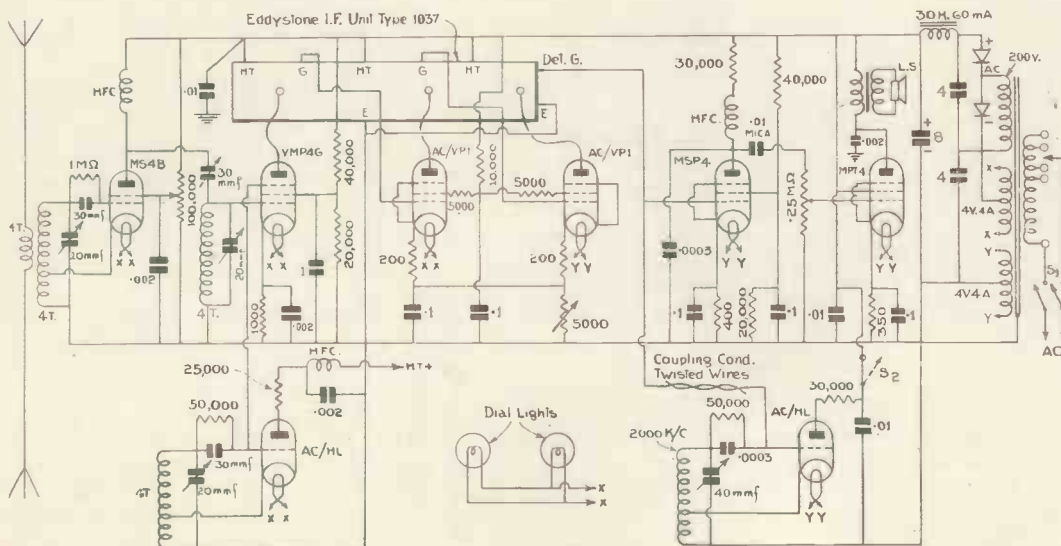

The receiver consists of eight valves in a more or less conventional circuit. The detector-oscillator is extremely efficient and we cannot stress too strongly the importance of adhering to the specified resistance and capacity values.

quality and only average gain. Screen-grid valves were tried, and although they worked well, anode bending the gain was not quite sufficient.

An MSP4 was tried and after juggling with the anode resistances and value of anode by-pass condenser satisfactory results were obtained. I cannot stress too highly the importance of using this valve as a second detector. In fact, all of the valves with exception of the output pentode should be used if maximum gain is required.

In most receivers changing a valve or two does not make much difference, but believe me in this receiver the choice of valves caused more worry than the actual circuit design.

The remainder of the circuit is straightforward, including the beat note oscillator. Metal rectification in the power pack is another feature than must be mentioned. Modulation hum and normal A.C. ripple are quite unnoticeable with only simple smoothing.

I will now go into more detail about the construction of the receiver. Screening is a point that requires consideration. All circuits are completely screened. The power pack, although in the open, is virtually screened as it is surrounded by other metal boxes.

The H.F. detector, oscillator and I.F. stages are completely screened.

If care is taken with the lead-in wire

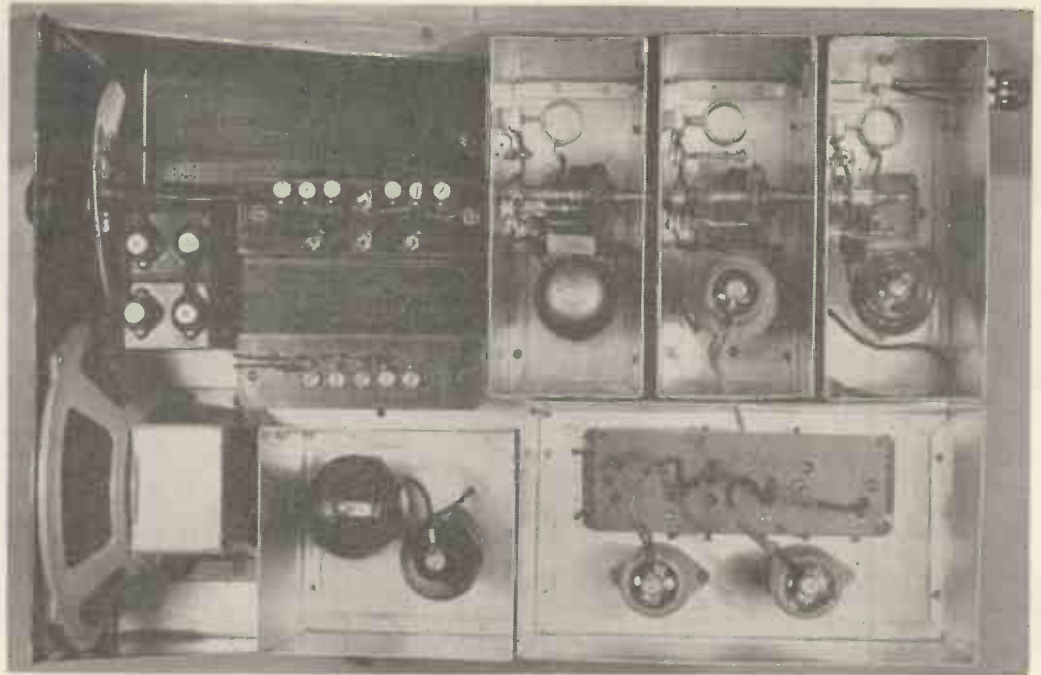

As can be seen from this view the second detector and pentode output valves are housed in the same screening box.

there will not be any stray pick-up, another important feature for duplex working.

It is suggested that a di-pole aerial be used with a transposed feeder, but if this is not possible then the earthy end of the coupling must be directly earthed and the aerial connected in the usual way.

Another 4-turn coil is used in the H.F. grid, but this must be tapped at a point about 1 complete turn from the negative end. This tap is connected to the cathode of the H.F. valve.

The H.F. choke in the anode of the first valve can be home-made in the following way. Wind 30 turns of 26 S.W.G. cotton-covered wire on a former the size of a pencil. These turns should be wound tightly after which the pencil can be taken out, the choke being self-supporting.

Coupling between the first and second stages is most important, so the air-spaced condenser should be varied until the best position is found.

Although an AC/HL type of valve is used as an oscillator in certain circumstances a power triode should be tried. This test should be made only with a weak signal.

There is no need to have a variable voltage on the screen of the first detector for this voltage is not critical. A VMP4G valve was chosen for the first detector position owing to its low capacity and steep slope. However, it must be used anode bend otherwise much efficiency will be lost. The I.F. transformer is an Eddystone commercial unit, and as a blueprint is given with each unit the technical circuit has not been shown. AC/VP1's work excellently in the I.F. stages, but require a permanent bias obtained by connecting two 200-ohm resistances in the cathode circuit. I.F. gain is varied by means of a 5,000-ohm resistance in the common cathode circuit to the AC/VP1. The second detector circuit is more or less conventional, and as previously explained, providing the resistance network is strictly adhered to the gain will be of a high order.

An MPT4 in the output stage is fully loaded with only a RC-coupled circuit.

COMPONENTS FOR U.H.F. 112-28 Mc. SUPER-MET

- | | |
|--|--|
| CHASSIS. | 2—30,000-ohm 1-watt (Erie) |
| 1—Special chassis with panel and screen boxes to specification (Scientific Supply Stores). | 1—25,000-ohm " " |
| CONDENSERS, FIXED. | 2—20,000-ohm " " |
| 1—8-mfd. type 0281 (Dubilier). | 1—10,000-ohm " " |
| 2—4-mfd. type LSA 9203 (Dubilier). | 2—5,000-ohm " " |
| 2—.0003-m.mfd. air-spaced (B.T.S.). | 1—1,000-ohm " " |
| 1—.0003-mfd. trimmer type SW85 (Bulgin). | 1—400-ohm " " |
| 2—.0003-mfd. type 665 (Dubilier). | 1—350-ohm " " |
| 3—.002-mfd. type 670 (Dubilier). | 2—200-ohm " " |
| 1—.01-mfd. mica type 670 (Dubilier). | RESISTANCES, VARIABLE. |
| 2—.01-mfd. type 4511 (Dubilier). | 1—250,000-ohm potentiometer (Reliance). |
| 6—.1mfd. type 4511 (Dubilier). | 1—100,000 ohm " " |
| CONDENSERS, VARIABLE. | 1—5,000 ohms " " |
| 3—micro-densers type 900, 20-m.mfd. (Eddystone). | SUNDRIES. |
| 1—40-m.mfd. type 900 (Eddystone). | 3—coils Quikwire (Bulgin). |
| COILS. | Quantity of 6BA nuts and bolts (Scientific Supply Stores). |
| 4—4-turn type 1020 (Eddystone). | 1—coil screened wire (Bulgin). |
| 1—Beat frequency coil, home-made to specification | 2—6-volt .3 amp. bulbs (Bulgin). |
| CHOKE, HIGH-FREQUENCY. | 4—1-in. shaft couplings (Bulgin). |
| 2—type CHP (Raymart). | 4—lengths 1-in. brass rod (Bulgin). |
| 1—type 982 (Eddystone). | 2—flexible couplings type 1000 (Eddystone). |
| CHOKE, LOW-FREQUENCY. | 4—yards 1 mm. flexible wire (Bulgin). |
| 1—type 30v (Sound Sales). | 1—oz. No. 30 S.W.G. D.S.C. wire (Peto-Scott). |
| DIAL, SLOW-MOTION. | 1—2 x 1-in. Paxolin former (Wearite). |
| 1—type semi-circular (Polar). | 2—EH9 Brackets (Bulgin). |
| 4—type K58 with four scales type IP8 (Bulgin). | SWITCHES. |
| HOLDERS, VALVE. | 1—type S80 (Bulgin). |
| 4—7-pin type ceramic chassis (Clix). | 1—S88 (Bulgin). |
| 4—5-pin type ceramic chassis (Clix). | TRANSFORMER I.F. |
| LOUD-SPEAKER. | 1—type 1037 three-stage unit (Eddystone). |
| 1—type, Baby (W.B.). | TRANSFORMER MAINS. |
| PLUGS, TERMINALS, etc. | 1—special for HT8 (Bryan Savage). |
| 1—SW47 (Bulgin). | VALVES. |
| 2—plug tops (Belling-Lee) | 1—MS4B plain (Marconi). |
| RECTIFIER. | 1—MSP4-met (Marconi). |
| 1—type HT8 (Westinghouse). | 1—MPT4 (Marconi). |
| RESISTANCES, FIXED. | 2—AC/HL-met (Hivac). |
| 1—megohm type 1-watt (Erie). | 2—AC/VP1 (Mazda). |
| 2—50,000-ohm " " | 1—VMP4G-met (Osram). |
| 2—40,000-ohm " " | |

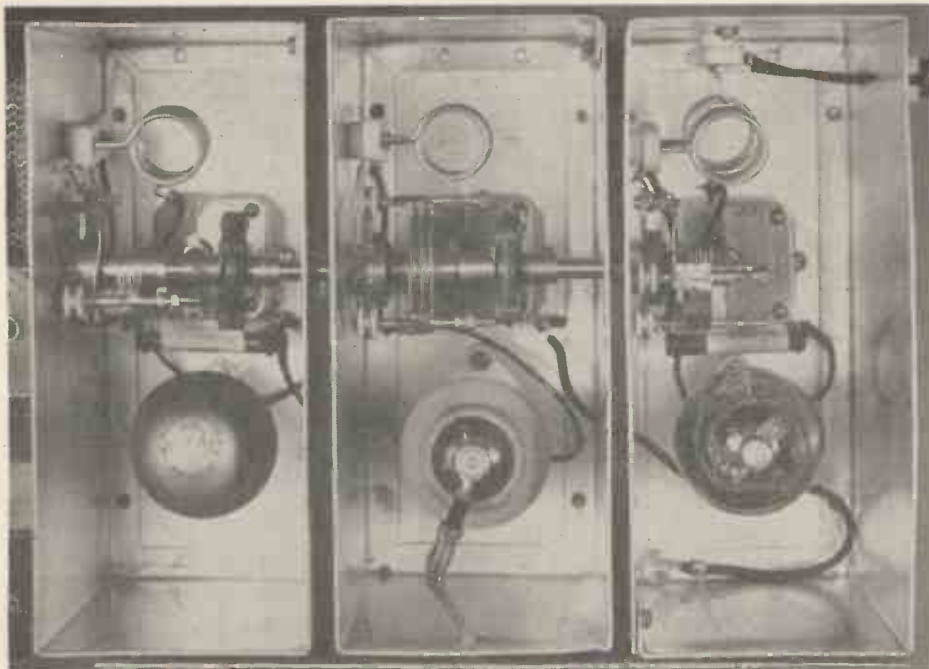

On the right is the electron-coupled R.F. amplifier with the first detector in the centre and the triode oscillator to the left.

On local signals this valve tends to be overloaded so to prevent poor quality the grid-leak takes the form of a .25 megohm potentiometer. The loud-speaker has a tapped matching transformer embodied as an integral component, so there is no need for an additional choke filter circuit. It must be remembered, however, that should head-phones be used or the output circuit altered it will be advisable to make some provision to stop the 45 m/a drain passing through the phone circuit. The beat-note oscillator is again the Dow electron circuit and tuned to the frequency of the I.F. coil. This oscillator coil should be home-constructed and consists of 60 turns of 26-gauge DCC wire-wound solenoid on a 1¼-inch former. The cathode tap is taken about 12 turns from the earthy end. A switch in the anode circuit of this valve is brought out through the panel as is the 40 mfd. tuning condenser for frequency variation.

The filament circuits are not wired in parallel. The transformer specified is made so that only two filament windings are required, both giving 4 amps at 4 volts. In this way the load is split up, each series of con-

nections carrying four amperes each. The H.T. circuit is quite conventional and consists of a HT8 metal rectifier in a voltage doubling circuit. The input to the rectifier is approximately 200 volts A.C., while the output with 4-micro-farad condensers in the doubling circuit is 270 volts D.C. For the smoothing circuit 8 micro-farads capacity and a 60 henry choke are ample. I did find that this circuit

was completely free from any modulation hum troubles.

No fuses have been embodied in the receiver and it is suggested that a Bulgin fuse plug be used instead. This is quite a satisfactory arrangement and does not spoil the layout of the receiver.

Construction should not present any difficulty. The chassis can be purchased from the Scientific Supply Stores ready built with all holes cut and the screening boxes ready for bolting in position. These boxes, by the way, have no bases so reducing cost and making construction more simple. With a little care the majority of the components can be fixed in position before the screening boxes are bolted to the chassis. There is little space to spare in the power pack section so it is wise to remember that the connections to the metal rectifier can be made before this component is mounted

As can be seen from the under baseboard photograph there is ample room for all the components, but it is a good plan to fix the two variable potentiometers with their associated extensions spindles immediately the valve holders have been fitted in position.

Room must be left so the lid of the beat-note oscillator screening box can be removed after the remainder of the components have been wired into the circuit. In the opposite corner to the beat-note is the only smoothing choke, and next to it mounted on a small aluminium bracket which is home-made is

(Continued on page 230).

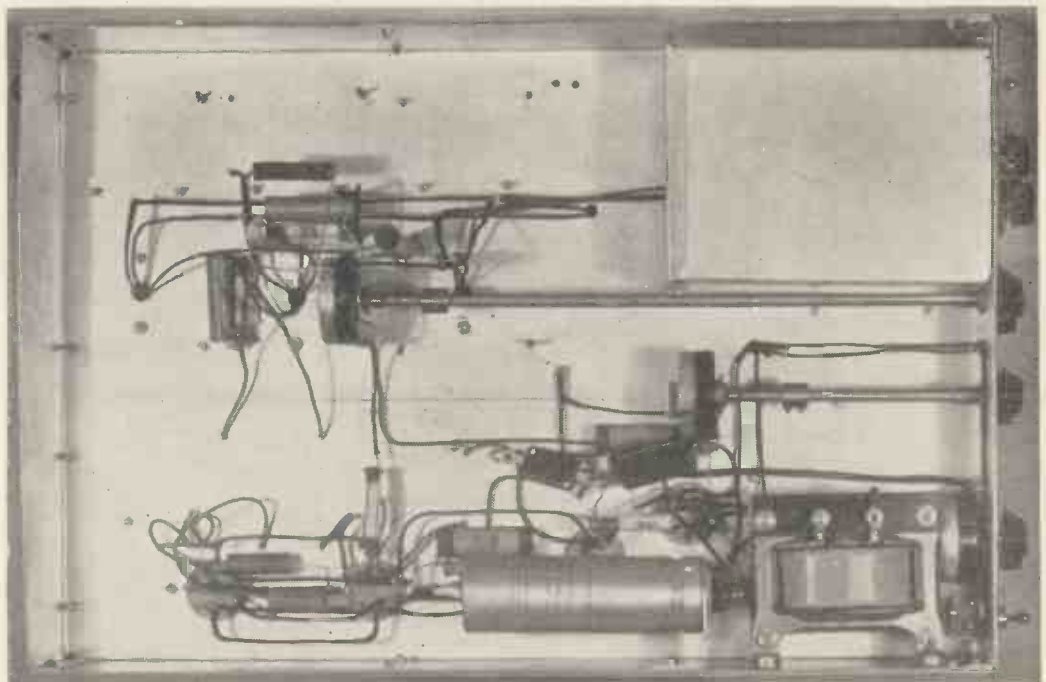

In the right-hand top corner is the beat-note oscillator. The switch and frequency control are brought out through the panel.

FOR THE BEGINNER THE TELEVISION SIGNAL

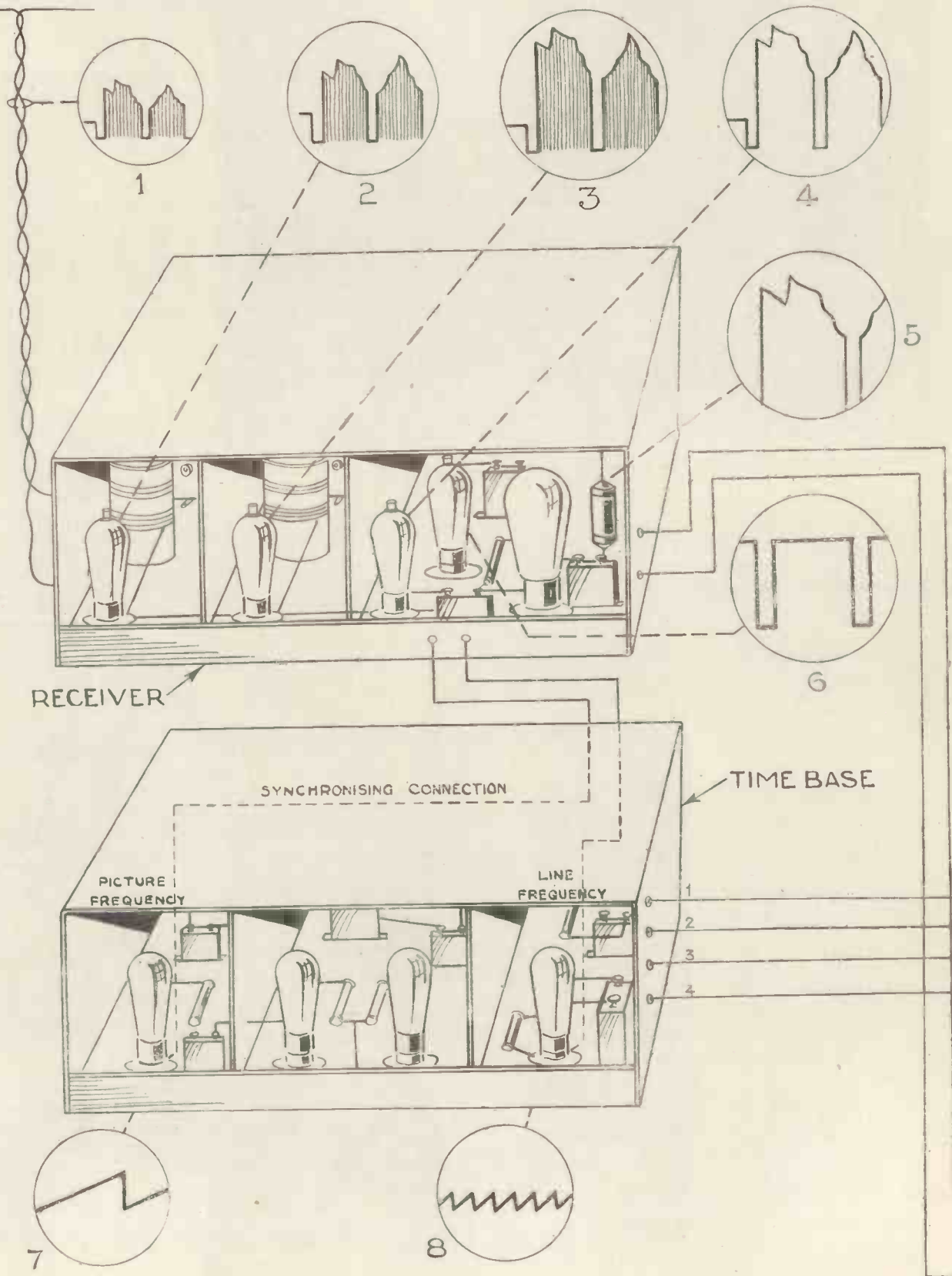

SIGNAL—FROM AERIAL TO TUBE

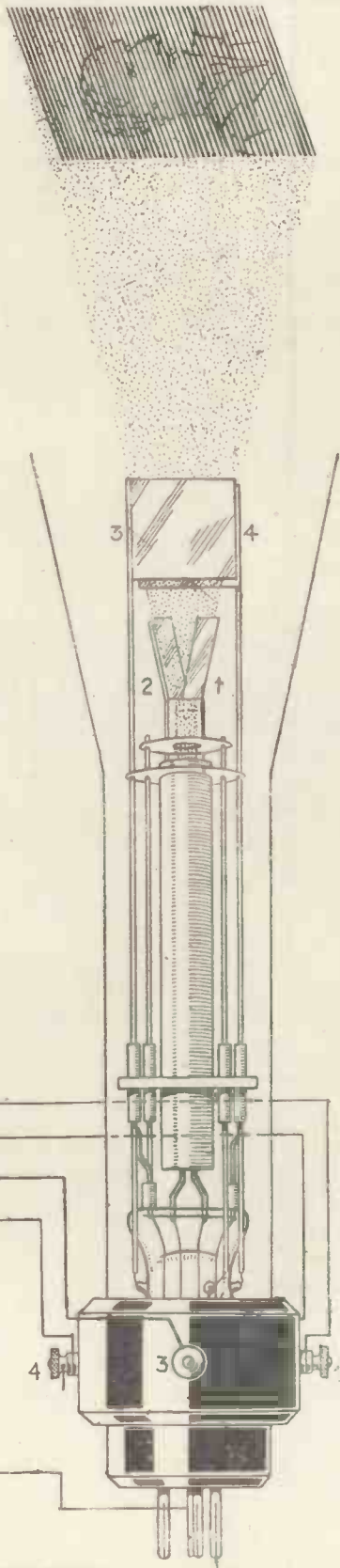

On the opposite page is shown the two main components of the modern television reproducer—the short-wave receiver and the scanning circuit for producing the lines on the cathode-ray tube screen. This is usually known as a “time-base” since its function is to move the beam in a definite way with regard to time.

The Receiver.

The television signal picked up by the aerial consists of the “picture signal” which is the equivalent of the audio-frequency modulation on an ordinary broadcast carrier wave, and the synchronising signal which occurs at the end of each line and each picture. This is shown as a temporary gap in the carrier amplitude. The modulated carrier wave (1) is amplified by one or more stages of H.F. amplification (2) and applied to the detector (3). After the carrier has been rectified, the modulation (4) and the synchronising signal (6) are separated, the latter being fed to the time-base. The rectified signal is further amplified (5) and is then applied to the grid of the cathode-ray tube to produce the light and dark variations in the intensity of the beam.

The receiver shown is a conventional “straight” circuit, but owing to the very short wavelength used, special coils and valves are necessary. An alternative type is the “super-het” in which several intermediate stages of amplification are interposed before the detector valve shown. The type of receiver used does not affect the general principles, however.

The Time-base.

The time-base consists of two electrical circuits which are designed to produce waves of a saw-tooth shape (7) and (8). These impulses are applied to the deflecting plates of the tube and move the beam across the screen in two directions at such a speed that 240 or 405 lines are drawn on the screen. The deflecting plates which move the beam are shown in the outline of the cathode-ray tube, marked 1, 2, 3 and 4, and they are connected to the corresponding terminals on the time-base. 1 and 2 give a movement of the beam 25 times per second (the picture frequency) and 3 and 4 give the line frequency (1/6000th second). The incoming synchronising impulses from the radio receiver are applied to the valves of the time-base and ensure that the lines are drawn on the screen in synchronism with the movement of the scanning spot at the transmitter.

The Cathode-ray Tube.

For a more detailed explanation of this the reader should refer to the issue of February, 1936, p. 68, in which the tube is shown taken apart. The beam of electrons which produces the picture on the fluorescent screen is produced by means of an H.T. unit giving several thousand volts. This unit is usually built as part of the time-base and connections from the receiver are made to the grid circuit as explained above.

Transmitting for the Beginner

This is the first of a series of articles on the elementary principles of transmitter design. The functions of various sections of the transmitter circuit and the principles governing construction are fully explained

By Basil Wardman, G5GQ.

QUESTIONS frequently heard in the various radio clubs are "What is the best valve to use?" or "What sort of transmitter shall I build?" With so great a variety of apparatus and circuits available, it is very perplexing for the beginner to decide which particular style of equipment to construct. Accordingly, in this series, the attention of readers will be drawn to the most important factors to consider in building and making the most out of a small transmitting station.

To say one type of transmitter, or one type of valve is best is impossible, as naturally the finances, power, location and constructional ability must be taken into consideration.

Of course, with the majority, cost is the limiting factor. Most amateurs wish to get the utmost for their money, but very often slight extra expense in one section of a transmitter will save considerably more money on the total outlay.

In the first rush of enthusiasm, on receiving a transmitting licence, there is a tendency to get "on the air" as quickly as possible. Unfortunately this is often followed by a feeling of depression due to the apparatus constructed being found unsuitable for further and improved work, causing the owner to go to more expense and trouble rebuilding it. When it is decided to embark on the first transmitter, go over individual requirements and see how they can best be met at a minimum of expense and a maximum of efficiency.

General Considerations

First of all, try to get a very rough idea of the possible gear needed—a "framework" sort of idea—for the details can be filled in as the scheme is completed.

Start by deciding whether to operate on one band only or whether to work on a number of bands. If one-band operation is decided upon, constructional work is simplified for it is an easy matter to design a self-supporting, low-loss coil which will be fixed permanently in the circuit, but it is very much more difficult to design interchangeable coils which are rigid, low-loss and self-supporting. Also, if coils have to be changed, the design of the chassis should permit of easy access to them.

Having decided the first point, next consider the maximum power. If 10-50 watts are to be used it can be obtained from a 350-volt or 500-volt power

unit, but if it is intended to use higher power, up to 100 watts or so, remember that 500 volts at 200 milliamps will give that input far more economically than 1,000 volts at 100 milliamps; especially as there are now quite a number of 500-volt transmitting valves on the market at very reasonable cost. Two of these in push-pull would handle 100 watts input.

After this, the question of telephony arises. If it is only intended to use C.W. this need not be taken into account, but if telephony is to be used, adjust the design accordingly. A station using telephony exclusively would, on the grounds of efficiency, be compelled to use choke control (Heising) modulation, and this would indicate the need for triodes in the modulated stage, with the amount of drive necessary with valves of this type.

On the other hand, a station with only telephony as a side line could use choke, suppressor grid, or control grid modulation, having a choice of all types of valve.

The last general point to consider is the type of construction to be employed. This is entirely dependent on the amount of space available. If space is unlimited, the amount of room required by the transmitter will not matter, but if space horizontally is at a premium, the vertical rack type of transmitter would be indicated. Similarly, if space vertically is limited, a breadboard type would be more convenient.

Circuit Design

For some obscure reason it has always been customary to deal with the crystal oscillator stage of a transmitter first, and then fit an amplifier to the end of the drive circuit. If there are insufficient drive volts at the end for the amplifier, either crystal oscillator volts must be raised, or else the amplifier must go short. Surely it is more reasonable, as the final amplifier is the one giving aerial power, to consider this first, and then design the rest of the circuit to suit it.

The valve is biased negatively until with normal H.T. volts no anode current flows. If the valve is of the high mutual conductance type, the negative voltage will be quite small and, assuming it to be 25 volts, apply the drive and assume the drive volts to be 50 volts peak developed between G and E. As A.C. volts are being applied the voltage will swing alternately positive and negative. On the negative half of the cycle, the volts

will add to the existing bias, making a total of 75 volts negative, and the valve anode will still take no current. On the positive half, however, the drive volts subtract from the negative bias, and so when the drive volts reach 50 volts positive the actual grid bias will be plus 25 volts (i.e., 50 volts positive—25 volts) and the valve will take quite a lot of power.

From this, an important fact is revealed. Every volt of negative bias the P.A. requires to give cut off has to be made up by the crystal oscillator or doubler.

Valve Capacity

Another point to notice is that the valve, owing to the proximity of the grid and filament, has a natural capacity. The larger the value of this condenser, the more difficult it is to develop volts across GE. In an ordinary L.F. amplifier, this capacity does not affect its working, but in a properly designed transmitting valve great care is taken to keep this as small as possible.

This seems irrelevant to the design of transmitting gear, but the great feature to realise is that it is often cheaper to buy a properly designed transmitting valve and save on the cost of the drive circuit than to use any old valve because it is lying around. Some time ago I measured the output of a TZ 05/20 valve and it gave almost exactly four times the output as a PX4-ACO44 type in exactly the same set up and with identical drive. It can be seen, therefore, that by paying slightly more for the valve four times the output is obtained. Other types give similar results, i.e., an LS5 requires as much drive for 10 watts as a Det-1 for 50 watts.

The type of P.A. value being settled, drive is the next consideration. For the sake of simplicity it is best to divide drive circuits into two classes—one with separate C.O. and separate doubler—the other with C.O. and doubler combined in one valve.

In general it is safe to assume that a triode P.A. needs to follow a C.O. or separate doubler, whereas a screen grid or pentode P.A. requires less drive and can follow a combined CO-doubler. For practical purposes a triode P.A. cannot get too much drive, but the reverse holds good for screen grids and pentodes.

After very carefully examining the above points, it should be possible to decide the most suitable type of circuit at the lowest cost.

THE G.E.C. AND TELEVISION

The General Electric Co., Ltd., has equipped a laboratory at Wembley specially for television research and development. Here is a brief account of the work being done in television and associated branches of the science.

ALTHOUGH the General Electric Co. has not made public its plans with regard to television, it is natural that a concern of this standing would not neglect the potential possibilities of the new science. Shortly after the publication of the report of the Postmaster General's Committee, therefore, a section of the G.E.C. laboratories at Wembley were specially equipped for television development. The first step was the installation of two high-definition transmitters—one

for radio transmission and the other for line. These were intended for research purposes only with a view to improvement in transmission methods and testing experimental receivers, the object in the latter case being to cover the design of theoretical circuits and the evolution of production designs for manufacture in the factory.

The development of cathode-ray tubes for high-definition television reception was, of course, included in

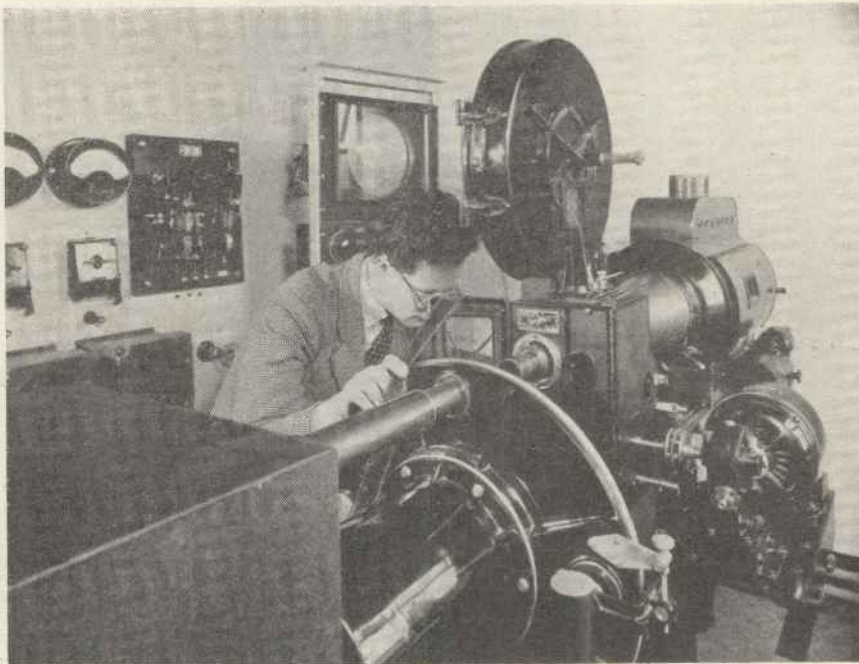

A television transmitter has been built in order to carry out experiments in receiver design. The G.E.C. is thus independent of transmissions from other sources. As will be seen from the photograph the apparatus is designed for transmission of film.

the research programme, and a large amount of work has been done on this piece of apparatus. The major problems investigated were (1) the method of focusing the beam, (2) the introduction of means for modulating its intensity, and (3) the desirable increase in size of the bulb. With regard to the latter, diameters of 12 inches or greater have now been obtained, giving a television picture of the order of from 9 ins. to 12 ins. wide.

atives kept in view. Testing plant, including life testing apparatus, has also been designed.

Recent developments in the G.E.C. laboratories have been concerned with preparations for quantity production for television receivers. A model production unit has now been in operation for some time for the purpose of studying manufacturing problems, and recent developments have been concerned with the application of the experience gained to production in the factory.

Cold-cathode Tubes

This photograph shows some of the apparatus used in the development of cathode-ray tubes at the research laboratories of the G.E.C. The operator is engaged in exhausting a tube.



An issue which in some ways is allied to the production of cathode-ray tubes has been improvements in cold-cathode high-tension discharge tubes which have been chiefly in the direction of efficiency, lumen output and maintenance. These factors are becoming of greater importance than hitherto, in view of the increasing application of these tubes to interior lighting.

In the "Cleora" type of tube the

G.E.C. PHOTO-CELLS AND AMPLIFIERS

efficiency is increased and new colour effects are obtained by coating the inside of the tubes with luminescent powders. These powders convert into visible light of different colours the quite invisible ultra-violet light emitted by the mercury-argon discharge. The colour of the luminescence depends upon the type of powder and its mode of preparation. Much of the ultra-violet light is not transmitted by the glass tubing, and in consequence it proves necessary, particularly in the case of some of the newer specially efficient powders, to place them inside the tubes.

Much work has been directed to the development of the powders. Some of those which have recently been evolved give surprisingly high efficiencies. Ordinary plain mercury blue tubes have a luminous efficiency of about 5 lumens per watt, but when these are internally coated with the new powders the light output, for the same power consumption, may be increased by four to twelve times according to conditions, including the nature of the powder. Pink, yellow, green and blue are amongst the colours which can be obtained with the new powders, some of which are approaching the commercial stage.

It has been found that the efficiency tends to fall off somewhat during life. However, some of the new powders which have been developed luminesce under the action of a discharge in pure neon. Excellent yellow, yellowish white and pinkish tubes have been obtained with these powders. The efficiency, although not so high as with some powders in a tube containing mercury, is nevertheless between one and a half and twice that of filament lamps of the same voltage. Even more important is the fact that the tubes show no appreciable falling off in efficiency or lumen output during life.

These tubes, either of one colour or a combination of colours give a very pleasing light suitable for interior illumination, although they are also likely to be of importance for advertising and display signs.

Photo-cells

The G.E.C. are well known as manufacturers of photo-cells and such characteristics as stability and frequency have always been held to be of greater importance than sensitivity. During the last year appreciable progress has been made in improving the emission of the cathode; at the same time greater stability and

ment. When the needle cuts the ray of light on this second photo-cell, the neon timing device is set in operation, this being arranged to give a fifteen second delay action. The object of this delay is that if within a period of fifteen seconds the milliampere needle falls away again after breaking the second ray of light, the load will not be switched on.



A self-contained photo-cell and amplifier which has uses for many industrial purposes.

less variation from cell to cell has been obtained. As a result, cells of normal sensitivity are now produced having much lower gas magnification and therefore their quality in respect of all their other characteristics is greatly improved. These cells, termed CWG, have a sensitivity of 100 mA/L, with a gas factor as low as 4.

Photo-cell Amplifiers

A photo-cell amplifier which has many distinctive features has been developed for the purpose of switching artificial lighting on or off when darkness approaches or recedes. A view of this equipment is shown by the photograph. Two photo-cell units are included.

The failing of daylight is registered through the photo-cell and amplifying valve to a large milliampere meter, the needle of which passes through a ray of light shining on to the first photo-cell equipment. In this case nothing happens until the needle travels further to break the ray of light on the second photo-cell equip-

ment. When the needle cuts the ray of light on this second photo-cell, the neon timing device is set in operation, this being arranged to give a fifteen second delay action. The object of this delay is that if within a period of fifteen seconds the milliampere needle falls away again after breaking the second ray of light, the load will not be switched on.

This arrangement prevents rapid switching on and off of the load should the needle fluctuate slightly just as the daylight is falling, when the light is at that critical point where a slight variation due to mist or cloud would momentarily allow the needle to fall away after breaking the ray of the second photo-cell equipment. If, however, the needle continues to obscure the ray of light on the second photo-cell for a period exceeding 15 seconds, then a neon capacity timing device operates the main contactor coil through a relay which switches on the load. This photo-cell equipment provides a positively definite switching on and off of the load, without any flickering.

Pilot All-wave Aerial

A new aerial kit with a low-impedance down lead has just been introduced by Pilot and marketed in this country by Streamline Radio, Ltd., of 146 Theobalds Road, W.C.1.

The kit consists of 68 ft. of aerial wire, a 75 ft. transmission line, insulators, lead in tube, junction block, lightning arrestors and a matching transformer, at the price of 27s. 6d.

This kit can be erected just as simply as a conventional aerial but has the advantage that when it is above static level the noise level in the receiver is almost completely eliminated.

On short waves this does not mean a big loss in signals. On the contrary on many wavebands there is a big increase in volume owing to aerial resonance. This is also noticeable on broadcast wavelengths. We can thoroughly recommend this Pilot aerial, as it is particularly effective in reducing motor-car ignition interference, and also noises generated by lifts and other domestic appliances.

For the portable Battery Transceiver described in the March issue a Yaxley three-point switch was specified. This can be obtained only from B. T. S., Faraday House, Charing Cross Road.

THE PRINCIPLES AND PRACTICE OF ELECTRON OPTICS.—IV

By N. Levin, Ph.D., A.R.C.S., D.I.C.

THE formula derived in last month's article for the focal length of an electrostatic electron lens formed by an aperture in a plate, namely,

$$f' = \frac{4V_a}{E' - E}$$

is subject to several assumptions and approximations. For example, we obtained the relation between the axial and radial field strengths, E_z and E_r , by supposing that there is no space charge in the region under discussion. This is not exactly true since owing to the electrons continually flowing through there must

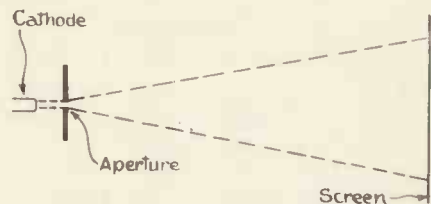

Fig. 1.—The image produced by a single-aperture electrostatic lens.

always be a certain space charge density which should be taken into account. However, in most cases the correction is small and can generally be allowed for in practice by varying the potential applied to the electrodes.

The most important assumption made was the inherent one that electrons do not attain the velocity equivalent to the electrode potential until they reach the aperture. As can be seen from the diagram, Fig. 1 in last month's article, they reach that potential before they arrive at the plane of the plate. That is, the equipotential line, corresponding to the electrode potential, curves away from the aperture into, in this particular case, the weaker field. Although the curvature of the field is taken into account in the equation relating E_z and E_r , in substituting the arithmetical figures for E' and E , we have to assume that the field is uniform on both sides of the aperture with a sharp discontinuity in the plane of the aperture.

This, as the diagram shows, is manifestly untrue. The equation we derived, that

$$E_r = - \frac{r}{2} \frac{dE_z}{dz}$$

means that if $\frac{dE_z}{dz}$ is zero, E_r is also

zero, whatever the value of the radius r . Hence as soon as we take into account some finite value of the rate of change of the axial field strength E_z with respect to the dis-

tance along the axis z , or $\frac{dE_z}{dz}$, we

automatically assume that E_r is finite and varies with respect to the radius and therefore that the equipotentials are curved in the neighbourhood of the aperture.

We should, in order to employ the formula more accurately, calculate the field strengths, say, on the left of the aperture not on the basis of the potential difference between the starting point and the plate divided by the distance between them, but on a shorter distance, the reduction being the amount by which the equipotential of the plate penetrates into the weaker field. Similarly for the right-hand side, the distance would be increased. The amount by which this distance is increased is not the same as that by which the left-hand side was decreased, because there is no sharp discontinuity between the two fields. In general, a much more rigorous mathematical treatment must be employed to give a more accurate result.

One more factor which introduces errors must be considered. This is the value of the potential V_a . It can be seen from the way the formula was derived that this potential represents the equivalent of the average velocity of the electrons in passing through the two fields. This is generally incorrect on two counts, one, that the average potential is not the right one to take, and, two, that the potential of the plate is not the average value. Again a stricter mathematical analysis would remove

this discrepancy, but the case of the simple aperture alone is not important enough. This will be done in the general case of a series of electrodes of various types.

In many cases the experimental results will agree excellently with the theoretical value and the conditions for which this agreement will be good can be easily seen from the above discussion. Thus, if the current is kept low, the space charge effect will be reduced until it can be made negligible. Then also if the low intensity field is made as little different from the stronger field as possible, the penetration of one field into the other will be considerably reduced

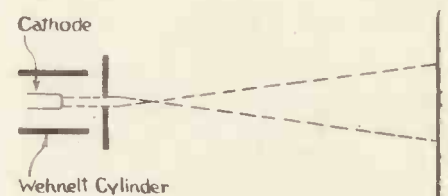

Fig. 2.—The concentrating effect of a Wehnelt cylinder in a hard tube.

and the errors due to this fact will be minimised. Finally, the potential applied to the electrode is also not far removed from the potential corresponding to the average velocity of the electrons. The condition for the total error to be not too great is that the ratio of the field strengths E'/E should be not more than about 4. Above this figure the discrepancy between theory and experiment is serious. Above a value of 10, the results are hopelessly in disagreement.

Davisson and Calbick were the first to give the above formula for the focal length of a simple aperture electrostatic electron lens, but they have not given the method of derivation. They checked the result experimentally and found good agreement. They also gave the formula for the focal length of a rectangular slot aperture as

$$f' = \frac{2V_a}{E' - E}$$

which corresponds to a cylindrical lens.

ELECTRON OPTICS AND THE CATHODE-RAY TUBE

The Single Aperture in Practice

The simplest practical application of the single aperture is in the case of the soft or gas-filled tube, in which the focusing is mainly caused by the positive ions of the gas. By itself the single aperture cannot produce a true focus on the screen. The reason for this will be clear when we consider the single aperture in a hard tube. The diagram, Fig. 1, shows a cathode either directly or indirectly heated, the first and only electrode with an aperture in it and a screen which may be some fluorescent material either on glass or metal. Whatever it is, it is necessary to have the screen at the same potential as the last electrode which is in this case our lens. This is because the first condition for deflection without distortion, i.e., a truly linear time base, is that deflection must take place in a uniform field. This will be discussed more fully in a later article.

Now since the screen and the last electrode are at the same potential, the field strength on the right-hand side of the lens, E' in our formula, is zero. Since the cathode is at zero potential and the electrode is at some positive potential, the field strength on the left of the lens, E , must be positive. Hence the focal length of the lens is negative. This means that there can never be a real focus

of an image of the cathode on the screen.

What is often seen and is often taken to be a real image, is a "shadow" thrown by the electrons in passing through the hole, particularly if this is small. As we know in the case of light beams, this "shadow" can be quite sharp and be apparently perfectly well defined. Moreover, it will be smaller than the true "shadow" owing to the different electrical "densities" on either side of the electrode. For instance, if the average potential on the left-hand side is V and that on the right is V' , then the ratio of the

electrical densities is $\sqrt{\frac{V'}{V}}$. This

has been already shown in a previous article. Hence the size of the shadow will be reduced in this ratio. Nevertheless it is not a real image and a small one could not be practically produced in a hard tube.

Even in the case of the gas tube, the single aperture would not be sufficient to produce a small spot because the positive ions will only focus a cone of electrons if the angle of this cone is small at the beginning. If the angle is large, the distortion introduced would be much too serious.

To produce the small angle there are at the moment three alternatives,

either to put the aperture some distance from the cathode, to make the aperture very small or to concentrate the beam before it enters the aperture. The first two alternatives would mean reducing the current to a negligible amount. Hence the last is the method generally adopted, the concentrating electrode being in the form of an open-ended cylinder completely surrounding the cathode and maintained at a negative potential, as shown in Fig. 2.

This cylinder is the well-known Wehnelt cylinder also known in the case of the hard tube as the grid. In this type it is used for modulation purposes, as the concentration can be varied by the potential applied to the grid, thus allowing more or less electrons to pass through the aperture to the screen. The diagram illustrates the concentrating effect of the cylinder, the arrangement shown being actually a typical example of an ordinary gas-focused tube.

The path indicated in dotted lines is that taken by the electrons when the gas is pumped out and the tube made hard. In the majority of practical electron optical systems the single aperture plays only a subsidiary part and the simple formula cannot be applied. It is necessary to take into account neighbouring electrodes which may and nearly always do considerably affect the action of the aperture itself.

"A U.H.F. 112-28 Mc Superheterodyne"

(Continued from page 223).

the 8-mfd. smoothing condenser.

The aerial and earth terminal block, and four four-turn coils are all mounted on to the screening boxes. It is important that all of these components be built up on ceramic bases. Losses cannot be tolerated.

Try as much as possible to keep the five screening boxes separated from one another by a small gap. A sheet of thin cardboard will do for this purpose.

The components on the front panel are reasonably symmetrical. At the base of the panel reading from left to right is the beat-note switch beat frequency control, H.F. regeneration, I.F. gain, L.F. volume and, finally, double-pole mains on-off switch. The tuning drive is of the dual-ratio type, the small knob which is concentric with the master tuner giving the high ratio gearing.

The screened leads to the H.F. detector and I.F. valves must be carefully anchored to the chassis, while the lead

from the grid of the beat-note oscillator to the suppressor grid of the second detector must also be metal-covered. There is no need in this case, however, to connect the metal covering to the chassis.

When fitting the 20 mmfd. tuning condensers it must be remembered that those used are of the new Eddystone type fitted with ceramic insulation and built-in ganging pieces. In case of readers using the old type of condenser some provision must be made for coupling the three condensers together. Flexible couplers are required to couple the first condenser to the second and the second to the third. I strongly advise readers not to use a solid coupler for it is very difficult accurately to mount the condensers in line. A length of brass rod couples the tuning condensers to the tuning drive. This must be very carefully fitted for it comes within $\frac{1}{4}$ in. of the HT8.

I feel quite sure that this summer with the introduction of television tests and the 5-metre field days that more

sets of this kind will be built. It must not be thought, however, that this receiver will be suitable for reception of television signals, for the receiver has not a sufficiently good low-frequency response. However, by simply using a 6 turn-coil the Crystal Palace and B.B.C. experimental transmissions can be received very frequently; in fact, at the moment they provide the most reliable means of testing the receiver.

A special aerial, preferably directional, is a distinct advantage, and so as to make the very most of the capabilities of this receiver we shall publish in the next issue a special article giving constructional details of a rotating 5-metre aerial which can be mounted on top of the receiver.

It must also be remembered that this type of receiver is extremely efficient on the 10-metre band, so if the receiver is constructed before the 5-metre days come along it can be accurately calibrated and lined up on 10 metres.

APRIL, 1936

The Amateur Bands Single-signal Super

By
E. J. Pickard, G6VA

This is the introductory article on the design of a special all-mains super for amateur use. The constructional details will be given in the May issue.

MANY amateurs are still sceptical as to the advantages of a superhet receiver on amateur bands. Conditions in congested areas are becoming increasingly difficult and it is not generally realised that a superhet is in such circumstances imperative.

A résumé of the more important considerations governing the design of an amateur superhet will probably prove this point very conclusively.

First, consider the requirements of such a receiver. They are:

1. High sensitivity.
2. Selectivity sufficient for single signal reception of C.W. and variable for phone reception.
3. Simple band-spreading.
4. Complete stability.
5. Beat note oscillator for CW.

In comparing the performance of a superhet with a good straight receiver, sensitivity may not be any higher, but

This is the S.S. Super designed by G6VA.

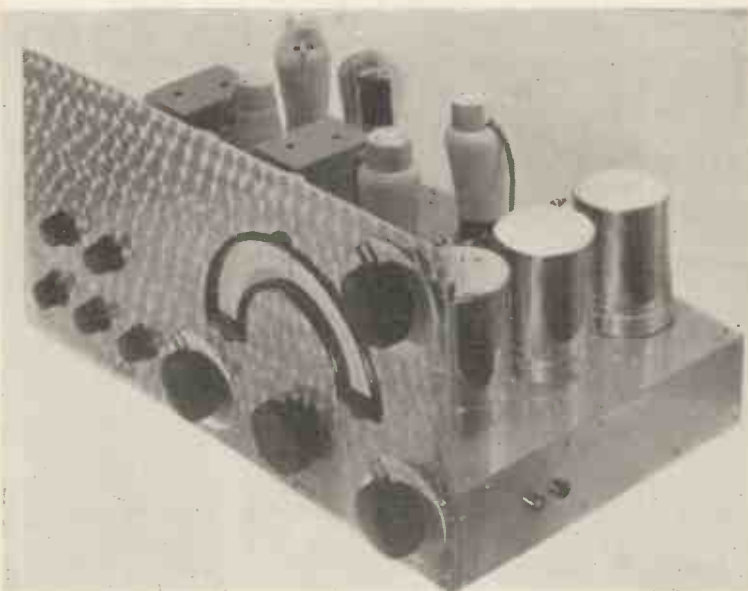

being passed on to the I.F. amplifier.

As an example consider an input-detector circuit tuned to 7,000 kc. with an intermediate frequency of 450 kc. and the oscillator 7,450 kc. In the anode of the detector will be present beats of 450 kc., 7,000 kc. and 14,450 kc. The I.F. amplifier easily discriminates between these frequencies and passes on only the 450 signal. A strong signal on 7,900 kc.-450 kc. above the frequency

crystal gate with a crystal resonating at an intermediate frequency. Second, peaked selectivity by means of regeneration in the I.F. stage, third, by operating the I.F. amplifier at a frequency of 40/50 kc.

The Crystal Filter

The crystal gate method is efficient and gives the greatest degree of selec-

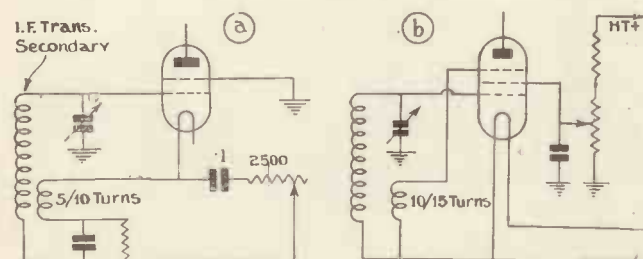
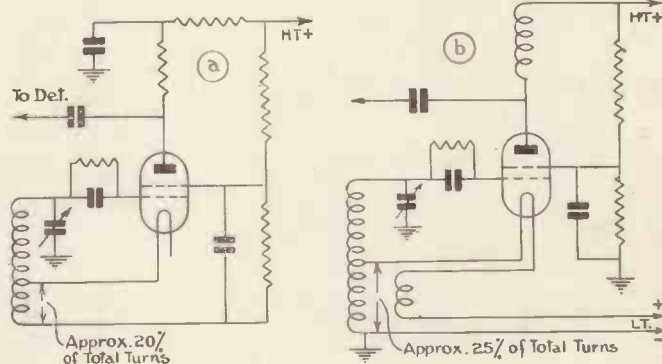

Fig. 1a.— The circuit above shows how to apply regeneration to a circuit using an A.C. valve. Fig. 1b is for battery operation.

Fig. 2.— Fig. a, on the right, is the Dow electron coupled circuit for A.C. valves. A similar circuit for battery valves is shown in b.



when selectivity and ease of control are considered the straight set falls down very badly.

Super-het Requirements

Consider the first two requirements, sensitivity and selectivity. In the superhet there are two distinct high-frequency channels for the attainment of both these features, each adding its quota to the overall effect. The intermediate-frequency amplifier, with band-pass coils, can be adjusted to give any reasonable degree of adjacent selectivity, but this does not overcome the possibility of an unwanted signal beating with the oscillator and the beat

of the oscillator, will produce the same I.F. beat of 450 kc. as does the wanted signal on 7,000 kc. so the I.F. amplifier accepts the interference along with the wanted signal.

Image Suppression

It can be seen from this that to reject image interference selectivity must be high at signal frequency. A tuned H.F. stage and regenerative detector will give good image rejection. Single signal reception of C.W. requires a selectivity of about 1 kc. in the I.F. stage and there are three well known methods by which this selectivity can be obtained. First, by the use of a

tivity but requires two I.F. stages so as to increase signal strength and to give the necessary selectivity to cut out the resonances inherent in the crystal. Another point is that only the most stable signals can be copied with the gate in circuit for the slightest signal wobble puts the I.F. out of resonance. To the amateur constructor the crystal hardly seems to offer any advantages.

An I.F. amplifier of 40/50 kc. will, with one stage, give high gain and good selectivity, but second channel interference is intolerable and no practical method of signal frequency selection is available. However, this method seems to open up an interesting possibility to the experimenter by having two changes of frequency, one somewhere in the

Practical Receiver Layout

2,000 kc. band and the second in the 40/50 kc. band.

Regeneration

The third method is the regenerative I.F. amplifier. This differs from the crystal gate, for while the crystal only passes wanted signals, regeneration peaks up the required signal above all others. This reactive effect can be obtained by connecting a feed-back coil in series with the cathode and bias resistor, controlling the amount of reaction with a by-passing condenser and variable resistance as shown in Fig. 1a.

microfarads so giving optimum results on high frequencies, assuming that the higher efficiency of the H.F. stage on the lower frequencies will make up for the losses in frequency conversion.

A disadvantage of capacity coupling is that no matter how small the capacity some loss in the size of permissible inductance on 10 metres is inevitable.

Generally speaking, oscillator injection to the suppressor grid of the detector, H.F. pentode *via* a condenser, is most satisfactory. The usual suppressor connection to earth is broken and a resistance of between 25,000 and 100,000

ohms inserted, the coupling condenser being of the order of .00005 to .0002 mfd.

rangement. This can be done, but single signal reception is not possible with an autodyne detector. The physical layout of the receiver is most important. A suggested arrangement showing the valve sequence and tuning arrangements in skeleton form is shown in Fig. 3. An additional valve for loudspeaker work is provided, while provision has been made for plugging headphones into the second detector circuit.

There is a 3-gang condenser R and also three separate band setting condensers C. A popular method of layout is shown in Fig. 4. Three tuning condensers can be ganged as indicated or alternatively the detector and oscillator can be controlled together, H.F. tuning being accomplished on the band-setting condenser.

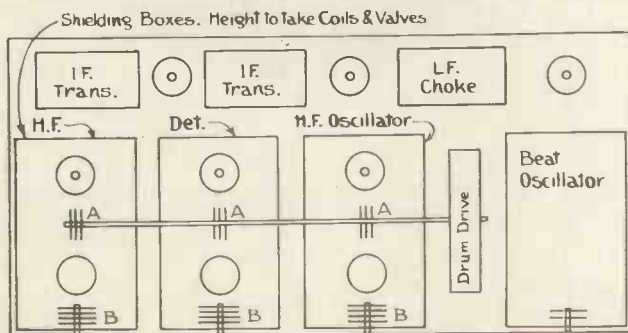

Fig. 4.—A chassis of this type is straight-forward and can be home constructed.

The alternative method for battery valves is shown in Fig. 1b.

To prevent I.F. drift when dealing with high selectivity it is desirable to use air-spaced trimmers in the I.F. transformer. The overall electrical stability largely depends on the intrinsic stability of the high-frequency oscillator, and for that reason the Dow electron-coupled circuit is to be recommended. The circuit is shown in Fig. 2.

The great advantage of this circuit is that a varying load may be imposed on the anode without causing frequency shift. Also the Dow oscillator is less susceptible to frequency change through voltage variation than is the triode oscillator. This is important as a variation of some 5 volts or so may arise with the adjustment of variable-mu volume control so de-tuning the oscillator sufficient to cause a change of note in the C.W. signal.

Oscillator Coupling

Coupling the H.F. oscillator to the detector is another problem. One way is by direct capacity feed from oscillator anode to the detector grid. This works quite well and is used in a large number of commercial receivers. It is apparent, however, that the feed will vary according to frequency, so a condenser, with an optimum value at 10 metres would be unsatisfactory at 80 metres and vice versa.

It is usual with this circuit to have a very small capacity of about 2/5 micro-

ohms inserted, the coupling condenser being of the order of .00005 to .0002 mfd.

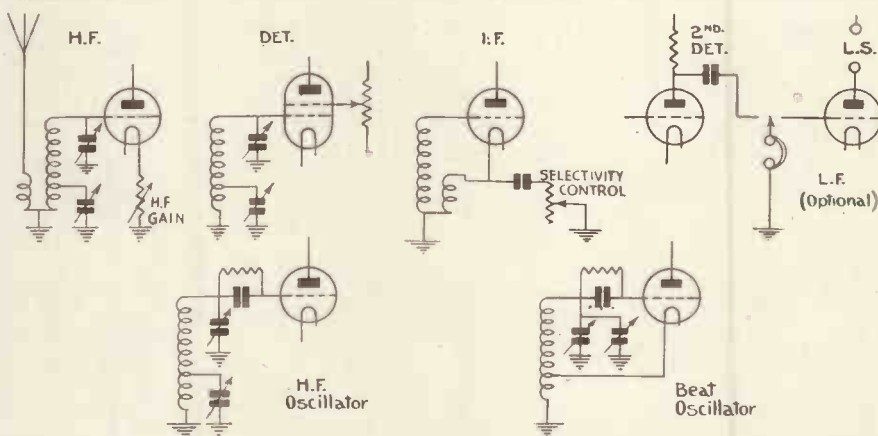

Fig. 3.—This is a good example of valve line-up to give optimum results in an amateur super-het receiver.

The beat oscillator coupled to the second detector for producing an audible beat for C.W. reception is made up of an electron-coupled circuit tuned to approximately 1,000 cycles on one side of intermediate frequency with a small vernier capacity to vary the note. A switch to break the H.T. to this valve serves to cut the beat out of circuit. It is possible to apply reaction directly to the second detector so economising in valves, but this circuit is not satisfactory unless it is used with a leaky grid second detector with the autodyne ar-

Salisbury & District Short-wave Club.

This Society is now in full swing and meetings take place every fortnight on Tuesday evenings at 7.45 p.m. Two lectures have been arranged for each evening in addition to the usual morse practice. At the last lecture Mr. C. A. Harley spoke on the "Detection of Wireless Signals," and Mr. R. Shilton on "Moving Coil Loud Speakers."

British Short-wave League.

We have obtained a copy of the "British Short-wave Listeners Review," a booklet issued and edited for the British Short-wave League by F. A. Beane. The amateur editor is Mr. R. D. Everard, and the assistant editor, B.R.S. 1724, S. J. A. Nichall. This booklet deals with short-wave stations, obtaining verifications, short-wave news and schedules of the commercial broadcasters. It is priced at 6d.

Reception and Transmission of Ultra-high Frequencies

In this article JOHN CREWE deals with the theoretical principle of the super-regenerative receiver and the more simple types of five-metre transmitter. The cause of super-regenerative hiss is fully explained.

ONE of the most popular receivers for ultra short-wave working is the super-regenerative. Peculiarly, and in contrast to the difficulties encountered in designing equipment to meet the requirements of higher and higher frequencies in the last few years, super-regenerative detection becomes less and less critical.

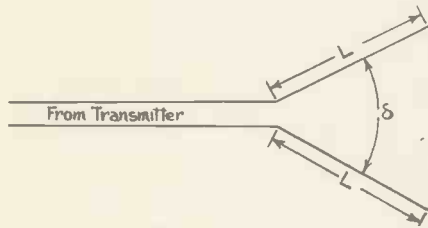

A simple directional aerial of this kind will often be ample for most low power stations.

To explain exactly how this form of detection takes place is not an easy matter, but some of its characteristics are simple to visualise. As it is used for phone and C.W. reception, the detector oscillates intermittently at a frequency above audibility (20 to 25 thousand cycles). In such an intermittently oscillating circuit, an incoming signal will build up to an enormous value depending only on the grid swing possible with the type of valve used.

When no signal is present the valve and circuit noises are built up by this action until they produce the extremely high noise or rush level so familiar to those using this type of detection. It is well to remember that this noise is the result of extreme sensitivity and that it is not an inherent phenomenon of super-regenerative action but would be, and is, present in any form of detection of equal sensitivity.

Filament Types

The noise is made up partly of the "Schott Effect" due to the irregularity of electron emission from the filament and partly due to the noises of the currents flowing in the tank circuits and leads. The part due to the emission can be eliminated to some extent by using valves having filaments from which the electrons are emitted more regularly. Pure tungsten filaments seem best, next the thoriated type, then

oxide-coated. There is little difference between the thoriated and oxide-coated types, but quite a large jump in noise takes place between the oxide type and heater type, not so much in the loudness of the noise but rather in the smoothness.

When a signal is received it will automatically reduce the sensitivity of the valve, and consequently background noise by an amount depending on the strength of the incoming carrier. A weak signal, well modulated, can be heard through the noise even though it is only slightly reduced. A strong signal will completely remove all background noise.

In so far as detecting action goes, the super-regenerative receiver behaves like a receiver with automatic volume control, the super-regenerative detector being inherently 100 per cent. automatic in controlling volume. One particular disadvantage lies in the selectivity of such a detector. It is extremely broad, due to the time-delay principle employed in building up the signal. It builds up in the circuit to its maximum value during the non-oscillating periods, and this action greatly reduces the selectivity. Another disadvantage is due to the radiation from the detector. When receiving, the detector oscillates intermittently and, of course, radiates a signal fully modulated by the quenching frequency. Another receiver operating within receiving range of the radiating receiver's carrier, picks it up and the beat notes between the quenching frequencies of the two receivers cause very serious interference. This may happen over quite large distances (a mile or more).

The more sensitive a detector of this type is, the more radiation it has and consequently the more trouble it makes. It makes little difference whether it be of the self-quenched oscillator type or of the type where the oscillator is intermittently stopped by a separate quenching valve. The self-quenched type is the more sensitive if constructed properly, since the stop and start of the oscillation period can be made sharper. This gives the signal more time to build up.

H.F. Amplification

It is possible to use an H.F. amplifier as a blocking valve between the detector and aerial, and to get some gain, but it is not easy to do it. Even the best screen grid valves at ultra-high frequency allow considerable energy to be by-passed in the wrong direction.

Then, again, the power cable to the set is usually of sufficient length to act as a fairly efficient aerial. Choke coils in the individual leads do little good, since the spurious capacities to the set at the cable entrance are sufficient to allow considerable H.F. power to pass to the cable.

The chief advantage of this type of receiver, namely, its extreme sensitivity, should be an incentive to the experimenter and engineer alike to develop improvements to remove its disadvantages. Little intensive study has been made of this method and the writer believes that big strides can be made with it.

The Super-Het

The superheterodyne receiver for these frequencies will also find a use in this field and will soon supersede the

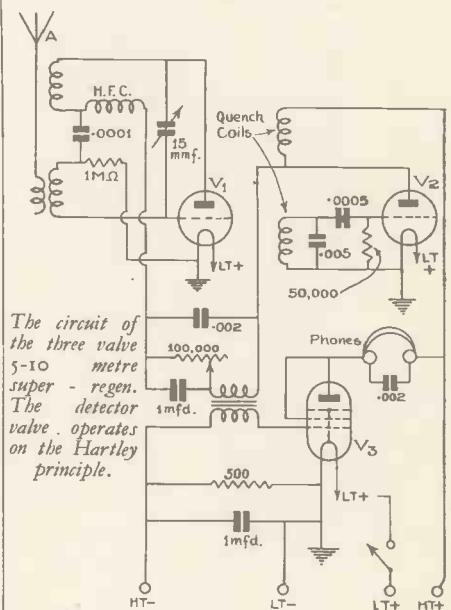

super-regenerative type. Until such time as the transmitters in general use have better frequency stability there is little to be gained by its use. There are many difficulties in the design of such a receiver, but it is well to bear in mind that if the sensitivity is increased to approach that of the super-regenerative type there will be an equal amount of valve noise if the receiver is not properly designed.

5-metre Transmission

Ultra-high frequency transmission of radio energy below approximately 7.5 metres or 40 megacycles has a field all its own. Its field of use is restricted to purposes where local communication is required, due to the fact that the wave does not return to the earth by reflection from the mirror-like Heavyside Layer. On very rare occasions it is possible that this takes place for brief intervals, but such transmission is of no value. Because of this fact several advantages are gained for its local uses. The so-called ground radiation only is utilised and no fading or variation in signal strength occurs.

inches. Elevations taken from a contour map are plotted on this circle along extended radii with a scale of $\frac{1}{8}$ in. equalling 10 feet in elevation. If a circle with a radius of 240 inches is drawn passing through both aerial locations and does not pass through any of the elevated points between, transmission is assured provided, of course, that the transmitters have sufficient power. If this line passes through one or more peaks on the way, transmission is usually still possible but each peak increases the attenuation.

When one station is located in the shadow of a high hill other facts enter

a range of from 6 to 15 miles, assuming this area is quite flat.

Low Power

One reason for the low power requirement is due to the fact that a fully resonant aerial can be used. A highly efficient transfer of power into radiation is possible in such a system as compared to one where loading coils are necessary to bring the aerial to resonance.

It is well to remember that within the area to the horizon more power produces higher field intensity and that at points in this area where, due to obstacles, the signal is weak, more power will remedy the situation.

Almost any type of circuit will oscillate quite efficiently at frequencies down to 70 or 75 megacycles, if a few simple precautions are observed. By far the most popular type has been the tuned-grid tuned-plate type in push-pull arrangement. At the highest frequencies this has a distinct advantage, since the valve capacities are in series across the tank circuit, but at frequencies up to 60 megacycles, there is little choice between it and the same circuit single ended, other than the increased power resulting from two valves.

In designing any circuits for these frequencies, short leads are very essential. It is hard to believe that a straight piece of wire a few inches in length has sufficient inductance to offer any impedance, but it is nevertheless true (an inductance of one microhenry offers a reactance of 400 ohms at 60 megacycles). For this reason the tank circuits should be connected to the valve elements by as short leads as possible. The design of ultra-high frequency equipment is as much mechanical as electrical, and the test "bread board" set-up cannot be transformed to a different layout in the finished set with equal success.

Transmitters

The greatest number of transmitters operating in the amateur bands are made up of directly modulated oscillators. In most sections of the country the frequency instability resulting from this does not cause any great interference. The time is rapidly approaching where this order of things will change. The master oscillator, power amplifier type, should be the present goal of the amateur. With it will come an improvement it is well to mention.

Frequency modulation occurs when the oscillator is modulated and becomes very noticeable when the percentage of modulation is high. Many side bands are produced and the energy is spread over them all instead of being concentrated in the two which are present when the carrier frequently is constant.

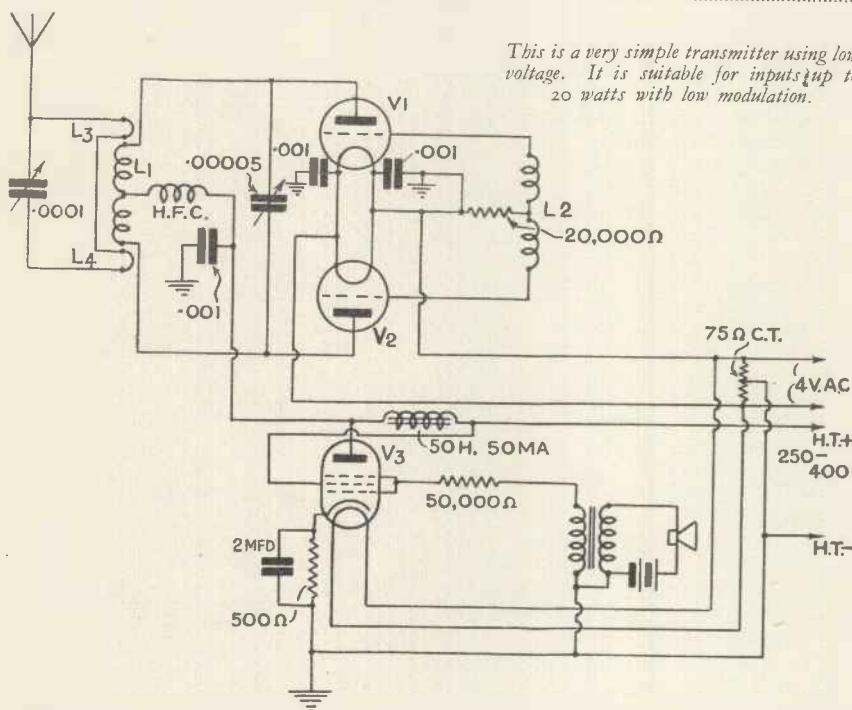

This is a very simple transmitter using low voltage. It is suitable for inputs up to 20 watts with low modulation.

The range of transmission may be governed by the elevation of the transmitting aerial and to some extent by the transmitter power. It is limited to a distance somewhat in excess of the radius of the horizon as seen from the transmitting aerial when the receiving points are at ground level.

Between two points 40 miles apart, if all the intervening space were at sea level, the earth curvature amounts to a rise of approximately 260 feet.

The "light horizon" in miles from an elevated aerial location can be found by taking the square root of the height in feet of the aerial above sea level and multiplying it by 1.23. The "radio horizon" is greater and the multiplying factor is approximately 1.4 instead of 1.23. An idea of whether transmission is possible or not can be had by using the "Haigis Method." A circle is drawn passing through the two station locations with a radius of 30

into the problem due to reflection and diffraction which provide individual problems in themselves and they usually are solved by changes of aerial location. These effects also come into play in all transmissions, but it is the writer's opinion after extensive tests that refraction plays the most important role.

For estimating short distance circuits such as occur in a city and its immediate surroundings, if reasonably flat, a fair estimate of range can be obtained by use of the above formula tempered with good judgment as regards height of aerial necessary to overcome local obstacles such as tall buildings (which offer considerable attenuation) and intervening hills.

The power required is very small. Using a transceiver putting about .5 watt in the aerial no difficulty should be found in contacting amateurs within

APRIL, 1936

This results in a weaker detected signal spread over quite a wide band. When detected in a super-regenerative receiver, the signal can be heard spread over a large proportion of the silent region.

If a good M.O.P.A. transmitter is used, the voice is observed quite sharply in the centre of the carrier, and since the side-band power is concentrated at one point the signal is louder for the same modulation percentage, and consequently greater range may be expected. In addition, the amplifier may be modulated to 100 per cent. per unit.

satisfactory and economy dictates their use. For the smaller units a single power supply for the entire equipment can be used if care is taken to ensure extremely good regulation. For the larger units the Class-B modulator should have its own power supply to prevent any frequency fluctuations of the oscillator due to the voltage drop in the supply when modulating.

The oscillator and power amplifier may be supplied from a second unit quite satisfactorily, or three units may be used, the oscillator then having its own supply.

A 5-metre super bet. must employ an efficient detector - oscillator circuit. The triode hexode when used in this way is the best double valve for the purpose. It will oscillate down to 4 metres without trouble.

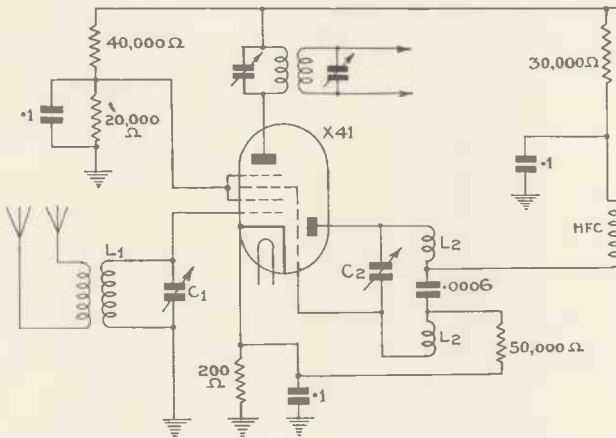

In the M.O.P.A. transmitter it is well to note that the oscillator should be designed with proper circuit constants so that, as far as possible, frequency stability is assured even though the supply voltages may vary slightly.

A sufficiently powerful oscillator is also a good thing in order that the coupling between it and the amplifier can be reduced sufficiently to present reaction of the modulated amplifier on it. Valves of the same size in both oscillator and power amplifier have been found to be satisfactory.

Modulation

Class-B modulators are perfectly

A well-designed 5-watt transmitter should be quite satisfactory for all amateur purposes.

Power Required

Little is gained by just doubling power. The signal strength is increased by only 3 db. which is hardly noticeable. For this reason power increases are generally made in multiples of 10, which give 10 db. gain for each step. In other words, if 5 watts is unsatisfactory, little improvement will be noted unless a jump to a 50-watt carrier is made.

Frequency.	Frequency.
1790	2SN
1791	5AK
1792.6	2QM
1794	5JU
1795	2UY
1800	6TL
1801	5ZJ
1802.5	5LL
1802.5	2IZ
1806	5MM
1808	5CH
1810	6BQ
1810	2LD
1810	5PP
1815	2DQ
1818.5	2OG
1824.5	2WG
1824.5	6UJ
1830	5KG
1830	6QB
1836.5	6RQ
1840	2JU
1844	6VD
1849	5CJ
1850	2CD
1850	5OC
1850	2HF
1850	2SR
1850	6UD
1850	6VD
1852	2KV
1857	6TQ
1857	2CF
1860	6QM
1861	2KL
1862	6WY
1869	2PS
1869	5PB
1870	2PL
1870	2LC
1870	5RI
1870.5	2WT
1874.5	2XP
1875	6WF
1881	6FV
1884	5KJ
1888	2XC
1890	2MI
1893	5RD
1899	5XF
1900	2PK
1910	2NO
1910.5	2GG
1913.5	2UJ
1916	5VT
1916.5	2GZ
1921.7	2OV
1925	6CT
1925	6UU
1930	5OD
1936.6	5IL
1940	6PA
1950	6KD
1950	5GL
1950	5SZ
1954	2GG
1960	5UK
1961	5OQ
1961	2UJ
1965.5	5LL
1970	6UT
1975	6OM
1980	6KV
1988	5WW
1990	6AU

160-metre Phone Reception in Gibraltar.

B.R.S. 2040 sends in the following report on 160-phone stations heard in Gibraltar by a B.E.R.S. listener. Stations heard have been G2OV eleven times, G5MM ten times, G5ZJ nine times, G6UW seven times, and G2KT six times, G5OC, 5JO, 2JG, and 6SR four times, 5IL three times, G2XC, G5PB, G5VS, 2LZ, 2WG and 2UZ twice, 6TL, 5YA, 5QY, 6AU, 5MU, 2JL, 6RQ, 5VT and 2PZ once. Best stations have been 5MM, 5ZJ, 2OV and 6SR, while the most consistent heard have been 5MM and 5ZJ. The star station generally is 5MM, closely followed by 5ZJ, 2OV and 6KV. The average strength of the louder stations is R7 to R5 QSO 4 to 5.

A Radio Society for the Channel Islands.

M. G. Bourke, B.R.S. 1784, and G2UR, are considering the formation of a Radio Society in the Channel Islands. Will any readers in that area please get in touch with B.R.S. 1784, at "Crediton," Samares, Jersey.

Top Band Frequency Register

MANY new stations have been added to this list during March. There are, however, still a number of stations whose frequencies are not listed, and we shall be glad to receive these in time for publication in the next issue.

Frequency.	Frequency.
1726	G6GO
1730	60K
1730	6WQ
1732	5ZJ
1740	5HO
1740	6WQ
1742	5WL
1748	5KV
1750	2WK
1752	2KL
1753	6KV
1754	6ZR
1754	6GO
1755	6PY
1756	2AO
1757	6YU

Frequency.	Frequency.
1759.5	5JW
1759.5	2KT
1760	5AR
1760	5BM
1762	2UJ
1762.5	2ZN
1764	5NW
1765	5ZQ
1766	6OO
1766	2WO
1766	5JO
1768	6PL
1769	5GC
1769.5	5FI
1770	5PR
1773.1	5BC
1774	6SO
1774.5	6NU
1776.4	5YW
1775	5KT
1775	6ZO
1776.4	5YW
1777	2JG
1778	6SY
1780	6BO
1780	5RI
1780	5BK
1780	6QI
1780	6BO
1780	6HD
1781.5	5VS
1782	5RT
1784	5IJ
1785.5	5ZT
1785.5	6IF
1786	5NP
1787.5	2XP
1788.5	2GG
1790	5MP
1790	5UM

An Experimental Short-wave S.G.-V-Pen

By Maurice Tapson, G6IF

This simple receiver has proved so satisfactory and popular that already G2LC, G2SO, G5VQ, G5XI, and 2BAI are using it on 1.7, 7 and 14-Mc.

AFTER trying all types of couplings between H.F. and detector stages, I found that on the average an efficient H.F. transformer gave 40 per cent. more output than the tuned grid or tuned anode systems. The only drawback as far as the constructor is concerned is making the coil, which consists of three windings, primary, secondary and reaction. Fortunately

connections. A special coil holder of the six-pin type is obtainable from the coil manufacturers.

Component values are not important. C1 and C4 are both .0003-mfd., C3, the detector grid condenser is .0001-mfd. and should preferably be air-spaced. R1 is used for dropping the H.T. to 70 volts to the screen of the H.F. amplifier. This should be 35,000 ohms with

this way these three condensers have their rotor plates automatically earthed and hand capacity is eliminated.

Most evenings when conditions are favourable the 19 and 25-metre American broadcast stations can be tuned in on the loud speaker while amateurs on five bands can be heard from all parts of the world. As can be seen from the circuit the receiver is quite straightforward and if the values suggested are adhered to there are no tricky points.

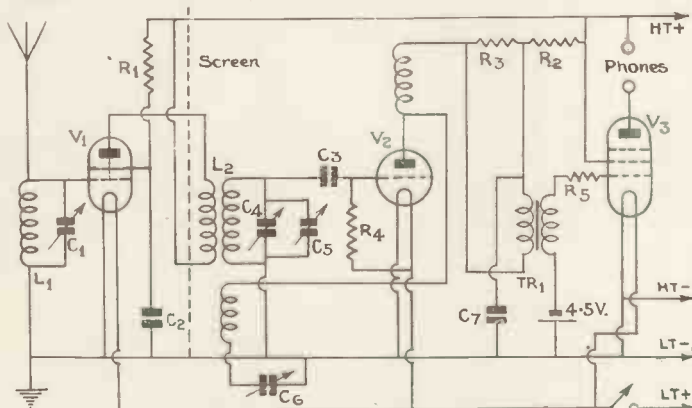

Fig. 1.—Readers should be able to construct the receiver from this simple theoretical circuit.

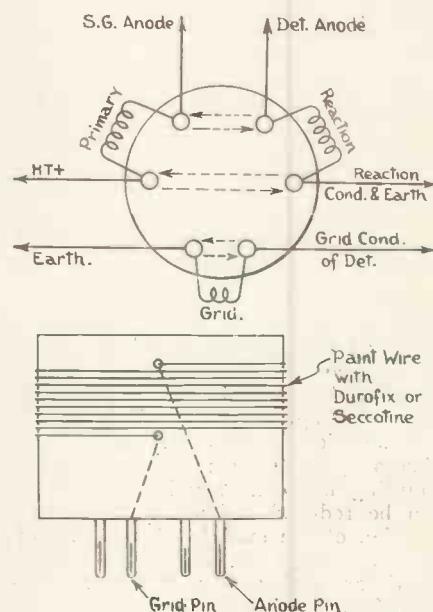

Fig. 2.—Although coils can be obtained ready made they can be home built very cheaply.

this point has been overcome by the introduction of 6-pin high-frequency transformers with reaction by Eddy-stone.

Valve Line-up

The receiver I use consists of three valves, a screened-grid high-frequency amplifier, triode detector, and pentode output. The aerial feeds into L1, a home-made coil that gives excellent results when tuned with a .0003-mfd. condenser. It consists of eight turns of 28 s.w.g. wire wound on a four-pin valve base for 40 metres, as shown in Fig. 1. The wire is fixed by Durofix or a similar solution. Two connections are made and although these are optional it is advisable to use the grid and anode pins so as to obtain maximum gap. For 20 metres four turns of 28-gauge wire and wound in the same way will cover the whole band.

Two H.F. Transformers

Two H.F. transformers are required, type 6LB for 20 metres and 6Y for 40 metres, these both being standard Eddystone coils. The connections to these coils are shown in Fig. 2, there being three windings and six separate

an H.T. supply of 120 volts. R2 is for detector decoupling and the value is approximately 10,000 ohms.

To prevent H.F. leaking into the L.F. stage a resistance R5 has been connected in the grid circuit of V3. This has a value of 30,000 ohms. A stabilising resistance of 50,000 ohms was found to improve reaction when connected across the primary of TR1.

The Output Valve

On the 160-metre band a Pen220A gave very satisfactory results and better quality from local stations, but on the higher-frequency bands the Pen220 gave greater output. For example R4 signals with the Pen220A were increased to R6 when the Pen220 was used.

It is important that the detector valve be entirely free from microphony for so much depends on the sensitivity of the detector stage. For a high-frequency amplifier use an S215 or an S215-B, both give satisfactory results.

The receiver is constructed on an aluminium baseplate with all of the small components beneath the chassis. The panel, however, is of ebonite backed with aluminium foil which is kept in place by means of C1, C4 and C6. In

The following components are suggested:—

- V1 S215 or S215-B.
- V2 HL2.
- V3 Pen220.
- L1 Grid coil (see text).
- L2 6LB and 6Y (Eddystone).
- L3 H.F. choke, type 983 (Eddystone).
- C1 .0003-mfd.
- C2 .1-mfd.
- C3 .0001-mfd.
- C4 .0003-mfd.
- C5 15-mmfd. Eddystone type 900.
- C6 .0002-mfd.
- C7 2-mfd.
- R1 35,000 ohms.
- R2 10,000 ohms.
- R3 50,000 ohms.
- R4 2 megohms.
- R5 30,000 ohms.
- TR1 1-5 inter-valve transformer.

A Power Pack for Small Receivers

This small power pack delivers 120 volts at 20 milliamperes and up to 150 volts with a lower current output

MANY readers have asked us to give constructional details of a small H.T. eliminator that can be coupled to existing battery receivers, so dispensing with the high-tension battery. We have designed this simple

absence of decoupling L.F. instability is set up unless the receiver is modified.

Those who wish to use A.C. valves can employ up to four with this transformer specified, but, of course, that will mean quite a fair amount of altera-

insulated sockets, these being two for H.T. and three for L.T. The panel light is connected across the four-volt L.T. supply and it should be noted that the bulb must be of the six-volt type.

Wiring is very simple, but care should be taken to see that the sleeving used will stand up to 200/300 volts but at the same time must not come too close to the aluminium chassis. To make absolutely sure that no short circuits can occur we have insulated all wires that go through the chassis by means of little ebonite spacing pieces.

This unit is not suitable without slight modifications for use with screened grid valves. These modifications consist of connecting a 50,000-ohm potentiometer across H.T. positive and H.T. negative taking the centre tap or slider to another socket on the panel. In this way the correct screen voltage can be obtained without difficulty. This potentiometer should be of the dead spindle type, particularly if a metal panel is used. It must also be of reliable make as a steady flow of 4.5 m/a passes through the windings.

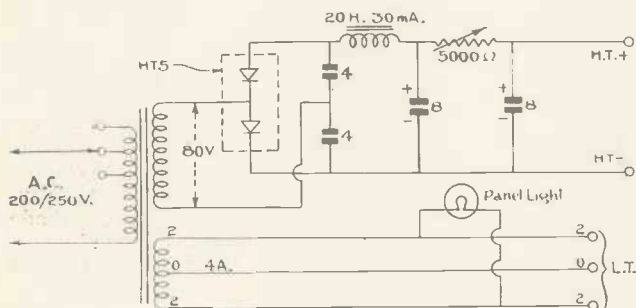

This circuit is self-explanatory and a more simple arrangement could not be imagined. The output is completely free from hum.

unit, which uses a Westinghouse metal rectifier, with the idea in mind that it can be used with the majority of battery sets we have already published, and with most of the small receivers constructed by short-wave listeners.

It can be seen from the circuit in Fig. 1 that an A.C. transformer is required with an output of 80 volts. A metal rectifier of the H.T.5 type is used in a voltage doubling circuit with two 4-mfd. paper condensers across its output.

We found that the smoothing circuit need only consist of one choke and one condenser. The 20-henry choke plus 8-mfd. condenser finally chosen gives such perfect smoothing that no hum can be noticed with the majority of single L.F. receivers.

A resistance of 5,000 ohms serves to reduce voltage if necessary and at the same time acts as decoupling. One of the major troubles with certain types of commercial units is that owing to the

tion to the wiring of the receiver.

The chassis consists of a 9 x 7 x 1 inch aluminium plate bent to size on which all of the components except the

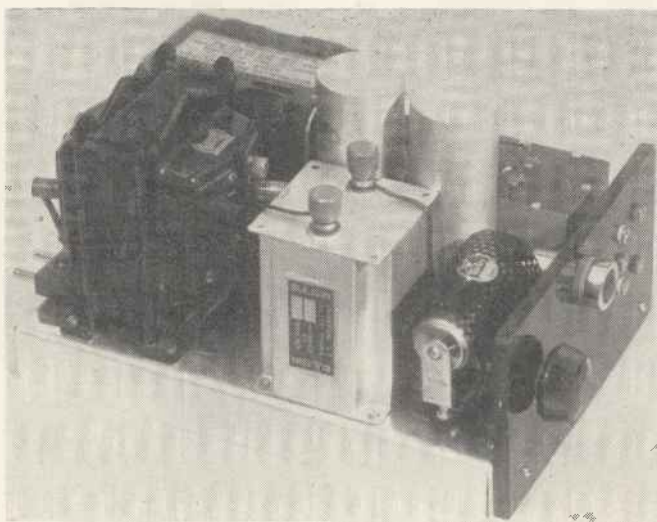

A good idea as to how the components are placed can be obtained from this illustration. Notice that the variable resistance is mounted on the panel and not on the chassis.

A High-tension Unit for Small Receivers.

- CHASSIS.**
1—9 in. by 7 in. by 1 in. 16-gauge aluminium (Scientific Supply Stores).
1—7 in. by 3 in. ebonite panel (Peto-Scott).
CONDENSERS, FIXED.
2—4-mfd. type 250 volt working (T.M.C.).
2—8-mfd. type 0281 (Dubilier).
CHOKE, LOW-FREQUENCY.
1—Type L.F.15 (Bulgin).
PLUGS, TERMINALS, ETC.
1—P28 (Bulgin).
1—P29 (Bulgin).
5—Insulated sockets (Clix).
RECTIFIERS.
1—Type HT5 (Westinghouse).
RESISTANCES, VARIABLE.
1—5,000-ohm. type CP63 (Varley).
SUNDRIES.
1—Dial light type D9 with 6-volt bulb (Bulgin).
Connecting wire and sleeving (Peto-Scott).
24—6B.A. nuts and bolts (Peto-Scott).
TRANSFORMER, MAINS.
1—Type W24 (Heayberd).

dial light and the variable resistance are mounted. As can be seen from the illustration, the mains transformer and H.T.5 are mounted side by side. In the centre are the two 8-mfd. electrolytic condensers, having on one side the Bulgin smoothing choke and on the other side two 4-mfd. T.M.C. condensers. The 5,000 ohms variable resistance is of the Varley power type and fitted with a protecting cover.

In the primary of the mains transformer is a Bulgin plug and socket so that the A.C. input makes good connection and there is no possibility of short circuit to the aluminium chassis.

H.T. and L.T. are brought out to five

South London and District Radio and Scientific Society

At a meeting held at the Society's Headquarters, Cotgrove's Restaurant, High Street, Southend-on-Sea, a lecture was given by Mr. S. Rutherford Wilkins on the "Design of Amplifiers for Television." He also dealt with the problem of obtaining adequate amplification over the exceptionally wide frequency range in television amplifiers.

Field days are now being planned for the summer months and the Hon. Sec., Mr. F. F. Adams, of Chippenham, Eastern Avenue, Southend-on-Sea, will be glad to hear from readers.

Keying the Transmitter

By W8FYN

CRystal-oscillator keying has as its primary advantage the possibility for break-in operation. The disadvantages seem to be concentrated in the sharp change in plate and screen current from a condition of no current at all to one in which the screen current and plate current are at full-load values.

The advantage of break-in may not be utilised by more than five per cent. of the amateurs who use CW. In any case, crystal-oscillator keying cuts the carrier completely so that no annoying backwash is carried through to the receiver to complicate copying.

Keying in the centre tap on straight pentode oscillators, such as the RFP15,

tal oscillator circuit. The crystal operates in the 80-metre band, the plate tank is tuned to the 40-metre harmonic and the cathode tank tuned to a frequency between 3.5 and 7.0 megacycles. The position for the key is indicated in the cathode lead at the low-potential or earthy end of the cathode tank. It should be noted that the control-grid return, through the grid leak and grid R.F. choke, remains connected to the H.F. and earth at all times. In the transmitter the key itself is used to break the cathode circuit. The leads running to the key from a plug on the transmitter front panel are eight feet long and are a part of the cathode return circuit when the key is down.

approximately 75 volts. This voltage is between cathode and heater.

If the heater insulation is of good quality, 75 volts is not excessive. This potential can be reduced to about 50 volts by connecting a 50,000-ohm resistor across the key. As mentioned before, shunt resistance across the key may give the signal some "whip."

It is not essential that the resistor be used unless the voltage across the open key exceeds 75 or 80 volts so that usually the shunt resistor can be dispensed with. In using this circuit, or in fact any keying circuit, the problem of key clicks can be tackled with best prospects for solution if the voltage across the key or relay is known. Keying in the cathode of heater-cathode type valves should not introduce a potential between heater and cathode of more than 100 volts.

The transmitter power supply gives 500 volts to the plate and 200 volts to the screen of the RFP15 Tri-tet oscillator. The total screen bleeder resistance is 15,000 ohms and screen current for both the oscillator and a following RFP15 doubler is drawn from this bleeder. With the key up, the plate voltage rises to 600 volts and the screen voltage rises to 310 volts.

The keying circuit shown has proved to be most satisfactory,

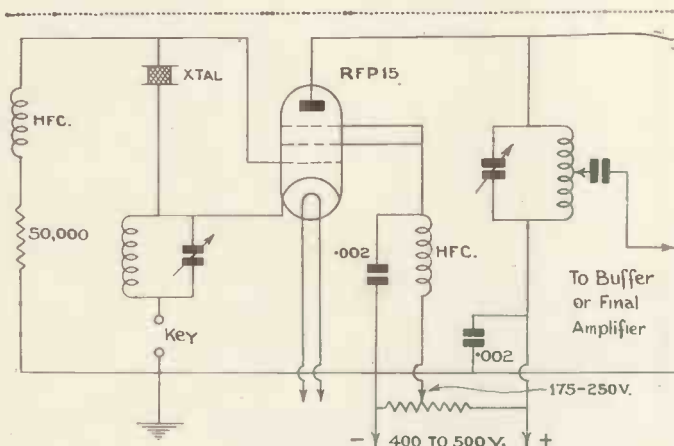

A 15-watt pentode of the 362 type works well as a straight or Tri-tet oscillator. The screen voltage is critical for maximum output so this should be obtained by means of a low resistance potentiometer.

is a straightforward procedure with no complications if care is taken to hold the screen-grid voltage at a value which does not materially change with the key up or down. Most of the crystal-oscillator circuits published for the RFP15 show the screen-grid supplied with current through a 40,000 or 50,000-ohm resistor.

In some cases, recognising the need for good regulation of the screen-grid voltage, a bleeder resistor of about the same value is connected from the screen grid to ground. By the use of the bleeder, chirp is reduced or completely eliminated when the crystal oscillator is keyed. With this arrangement, screen-grid voltage regulation is improved. The fact that it will not be perfect is quite obvious, however. A much better arrangement would call for not more than 15,000-ohms from the plate supply voltage positive lead to earth or H.F. with the screen-grid voltage tapped off this bleeder. Most oscillator power units will supply more than enough current to feed the oscillator, a buffer stage and the bleeder current required for the screen-grid supply circuit.

The diagram shows the Tri-tet crys-

A better arrangement is to use a small keying relay connected with short leads to ground and to the low end of the cathode tank circuit.

It will be noted that no resistor or capacity-network is shown in the key circuit. Key clicks were not found to be at all bothersome in a broadcast super-heterodyne only twenty feet from the transmitter. However, combinations of shunt resistance and capacity were tried with interesting results. It was found that the pitch of the signal could be varied several hundred cycles by connecting either resistance values between 10,000 and 100,000 ohms, or capacities up to 1-mfd. across the key jack at the transmitter panel. For clean, unvarying pitch signals the best arrangement was the simple one shown in the diagram. No shunt resistance or capacity was needed although either one might be helpful in some other case.

Shunt resistance across the keying circuit was useful in one respect. Measurement of the voltage developed across the open key, using a 1,000-ohms-per-voltmeter on the 750-volt scale, showed

DX on 20 Metres

Low-power stations on the 20-metre band are finding conditions good for real DX. Perhaps most of the high power stations have migrated to the 10-metre band for the congestion has decreased during the past few weeks.

J's (Japanese) are rare stations in this country. A good plan to listen round the band until plenty of W's are heard calling J's. Then is the time to locate the frequency of the J station, after which go for him. This trick works very often, as J's can be brought in by G's at the same time as by W's.

Don't worry about QRP. W6 and W7 have been raised in this country on 30 watts reporting signals R6 QSA5, but on ten watts input an R5 signal should be obtained.

The following frequencies are those generally used by VK's, now audible in this country:

VK2OC—7,005 kc.	VK2PX—7,080
VK2KS—7,010	VK2VE—7,090
VK6HW—7,015	VK2RF—7,120
VK3GP—7,018	VK3KA—7,140
VK3GE—7,035	VK7AB—7,180
VK3EG—7,040	VK3ZW—7,200

DIGESTS AND DATA

ABSTRACTS FROM AUTHORITATIVE CONTRIBUTIONS ON TELEVISION IN THE WORLD'S PRESS

SPECIALLY COMPILED FOR THIS JOURNAL

The Electron Telescope. Electronics, Vol. 9, No. 1, Page 10.

At the annual meeting of the American Association for the Advance of Science, what is claimed to be a new application of electron-optics was described by Dr. Zworykin and Dr. Morton. This piece of apparatus, which brings the field of electron-optics a stage nearer to its sister science, the optics of

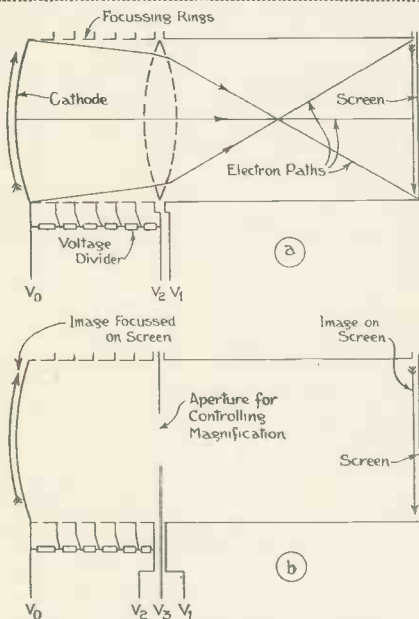

light, has many unique applications. One of these uses is the translation of infra red light directly into visible light with no intervening photographic stages. One great advantage claimed for this apparatus is that spherical aberration is eliminated by utilising a special curved photo-electric cathode. The diagram shows the construction of the electron telescope. As shown at A, the optical image (the arrow) is focused on to the transparent photo-electric cathode. The electrons produced take the paths shown, and on hitting the Willemite screen, re-create the image in an inverted position. The electron lens consists of two cylinders, the

left of which is broken up into a series of rings to aid correct focusing. A glass lens acting on light rays in the same way would have the position shown by the dotted line. At B is shown a model containing an aperture by which the magnification can be controlled electrically.

Input Resistance of Vacuum Tubes as Ultra High Frequency Amplifiers. By W. R. Ferris, Proc. Inst. Rad. Engrs. Vol. 24, No. 1, Page 82.

It is mentioned that conventional type valves operated as voltage amplifiers at low frequencies require no great amount of grid input power, but when these valves are used in ultra-high frequency circuits considerable amounts of power are required. An accurate representation of the grid input conductance for electrodes of any shape is given by the expression $g_g = K s_m f^2 \tau^2$, where g_g is the input conductance, s_m the grid-plate transconductance, f the frequency, and τ the electron transit time. K is a parameter which is a function of the geometry of the tube and the voltage distribution. The magnitude of g_g is such that it is the principal limitation for amplifiers at frequencies of the order of 100 megacycles, and amplification at

frequencies as low as 15 megacycles is effected.

The experimental work carried out was done by a direct substitution method which was chosen as the most suitable means for accurately measuring the input conductance. A schematic diagram of the test circuit is given here.

The use of miniature tubes with very short transit times is given as a practicable method of increasing the amplification obtainable with conventional circuits.

Oscillograph Amplifiers for Very Wide Frequency Ranges. By M. Von Ardenne, Wireless Engineer, Vol. 13, No. 149, Page 59.

In this paper the particular requirements of amplifiers for increasing the sensitivity of cathode-ray

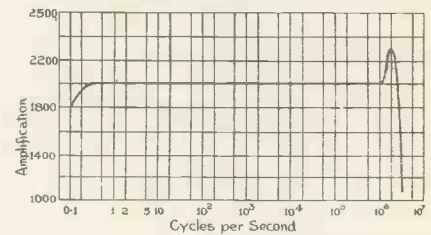

tube oscillographs are discussed and an account is given of the design and construction of an amplifier of this type. An amplifier is described and discussed which gives almost uniform amplification from 0.2 cycle to 3×10^6 cycles. It is stated that from about 0.5 cycle to 10^6 cycles, the phase shift in the amplifier may be neglected. The amplification curve of this amplifier is given.

An Analysis of the Effects of Space Charge on Grid Impedance. By D. O. North, Proc. Inst. Rad. Engrs. Vol. 24, No. 1, Page 108.

In which previous theory of transit time phenomena in high vacuum diodes is extended and augmented so that it provides an explanation of the high-frequency behaviour of high μ

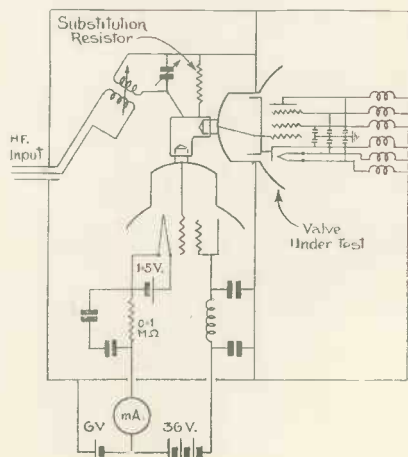

Abstracts from Television Contributions in the World's Press

amplifiers with parallel plane electrodes. The expressions are derived for internal input loading and capacity, showing the dependence upon frequency, voltages, and tube dimensions, it is also shown how the theory in its present form may be applied to many commercial valves of cylindrical design.

It is stated that "hot" input capacity exceeds the "cold" value. The magnitude and dependence upon parameters is given, the increase is primarily due to space charge, but it is stated it also depends upon the ratio of the electron transit time between control grid and plate to the transit time between cathode and control grid.

The great importance of transit times in the design of valves for work with ultra high-frequencies is stressed.

Voltage Measurements at Very High Frequencies. By E. C. S. Megaw, *Wireless Engineer*, Vol. 13, No. 149, Page 65.

It is considered that the most suitable arrangement for accurate measurement at frequencies of 10^7 or higher is one in which a condenser, in series with a diode, is charged to

the peak voltage. A summary is given of previous work carried out on these lines, and a statement of the factors which decide the best value for the condenser, and a determination of the conditions for negligible leakage error. Errors are discussed which are peculiar to high-frequency working, resulting from the finite interelectrode capacitance of the diode and finite inertia of the electrons.

Results indicate that it is possible to measure accurately the voltages of 10 volts or higher at frequencies up to approximately 100 megacycles, without high-frequency calibration, and a useful estimate can be made at frequencies up to approximately 1,000 megacycles.

A second paper is to be published in which an account of the experimental investigation of this type of voltmeter will be given.

Commencement of the new Television Transmitter. *Funk-Technische Monatshefte*, January, 1936. *Beilage Fernsehen und Tonfilm*, Page 1.

Consists of a short description of the new television transmitter that

commenced in Berlin on December 23, 1935.

The Television Receiver of Fernseh A. G. By Dr. Ing. George Schubert. Page 2.

In which is described the television receiver produced by Fernseh A.G. This is a table model giving a picture of approximately 19×23 centimetres.

Television Abroad. Page 4.

The position of television in England and America is discussed.

A New Experiment in Cathode-ray Tube Sanning of Film with a large number of lines and pictures. By Manfred von Ardenne, *Funk-Technische Monatshefte*, February, 1936, *Beilage Fernsehen und Tonfilm*, Page 9.

The question of scanning film for high-definition transmission is dealt with, several pictures of the apparatus used being given.

The Television Receiver of C. H. F. Müller, A.G. Page 15.

Is a cabinet model receiver using a cathode-ray tube.

A NEW GERMAN TELEVISION RECEIVER

FERNSCHEN and Tonfilm recently published details of a new Telefunken television receiver and we give below the general details of this. Sound and image are received on the common aerial (2 m. long) and amplified in an r.f. stage. The mixing stage which follows furnishes at the same time the intermediate frequencies for the sound and for the picture channel, a special mixing tube with built-in oscillator circuit being used. This stage contains, beside the oscillator circuits, two strongly damped circuits, the aerial circuit and the intermediate circuit, both with variable self-induction so as to cover the range 35 to 50 mc.

The amplifier for the image consists of two stages: a resistance in the cathode lead of one of these i-f amplifiers allows adjustment of the brightness. The output is led to the oxide-coated electrode of the cathode-ray tube, the bias being adjusted with

the aid of a resistance which controls the contrast in the picture. The band-width amounts to 1,400 kc. Despite this width the amplification per stage does not drop below 15, a result rendered possible through the use of intermediate frequency and band-filter circuits with very low losses.

The width of the sound channel is

BINDING CASES AND INDEXES FOR 1935.

Binding cases and indexes for the 1935 volume of "Television and Short-Wave World" are now available. The cases are full brown cloth with stiff boards lettered in gold. The price, including the index, is 2/9 post free. Indexes may be obtained separately and the price is 6d. post free. Orders should be addressed—

BERNARD JONES PUBLICATIONS, LTD.,
CHANSITOR HOUSE,
37/38 CHANCERY LANE, LONDON, W.C.2
and should be accompanied by the remittance.

29 kc. allowing an extremely faithful reproduction.

The deflection of the electron beam is obtained by means of a scanning stage to which the output of the image amplifier is fed. It rectifies first the image current and separates the image modulation from the picture and line impulses. From a push-pull output stage these impulses are led to the deflecting plates.

The screen measures 19×22 cm. and is inclined 12° to the vertical. A single power transformer is used which supplies two rectifiers, a special power valve for the cathode-ray and an ordinary power valve for the amplifiers. The cathode-ray tube requires 5,000 volts; this potential is produced by means of a Greinacher circuit from 1,800-volt windings on the transformer. Despite the absence of voltage regulators the potential remains sufficiently constant.

The set possesses 13 valves, 5 diodes and rectifiers, and one cathode-ray tube.

FLUORESCENT SCREENS FOR CATHODE-RAY TUBES

The following is an abstract of a paper read before the *INSTITUTION OF ELECTRICAL ENGINEERS* on March 4th, by *LEONARD LEVY, M.A., D.Sc.*, and *DONALD W. WEST*, and is published in this journal by special permission of the Institution.

THE fluorescent screen which is employed to render the effects of the electron stream visible in a cathode-ray tube is a most important portion of the apparatus.

Fluorescence and Phosphorescence

Luminous radiation emitted by luminescent substances is of two types:—

(a) *Fluorescence*.—An emission of luminous radiations which ends immediately the stimulus of exciting radiation has ceased to act, is known as fluorescence.

fluorescence during the first period in which the exciting radiation is acting. The intensity of phosphorescence diminishes continuously immediately upon the cessation of the exciting radiation. The rate of fall of luminescence is greatest at the beginning and decreases exponentially with lapse of time.

Fluorescence is the conversion of some form of energy into radiation in the visible spectrum. Phosphorescence is the emission of latent energy in this region.

According to some authorities, the distinction between fluorescence and phosphorescence is not a rigid one. A substance when fluorescent can be regarded as being in a meta-stable condition, the luminescence being a phenomenon which is associated with a state of strain into which the molecule has been thrown owing to the incidence of the exciting radiation. If the meta-stable condition of the molecule only persists so long as the exciting radiation is present, we have fluorescence. If, however, the molecule is not restored to its original condition immediately upon the cessation of the exciting radiation, the luminescence persists as phosphorescence.

It is a matter of experience that preparations which

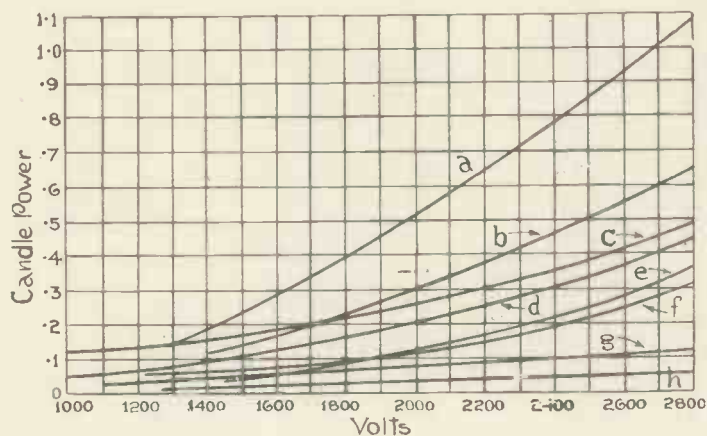

Fig. 1.—Curves obtained by maintaining current constant at 150 microamps. and varying applied voltage.

- (a) Preparation of Z 23 (zinc sulphide and zinc-cadmium sulphide).
- (b) Zinc sulphide U 36.
- (c) Zinc sulphide G 86.
- (d) Zinc-cadmium sulphide B 11.
- (e) Zinc-cadmium sulphide (foreign preparation).
- (f) Willemite.
- (g) Cadmium tungstate.
- (h) Zinc phosphate.

According to Stokes' law, the wavelength of the fluorescent light is always greater than that of the exciting radiation.

(b) *Phosphorescence*.—Phosphorescence differs from fluorescence in that it refers to light which continues to be emitted by a luminescent substance after the exciting radiation has ceased to act. The fluorescence of a luminescent body builds up almost instantaneously to a maximum intensity, which remains constant over a considerable period of time so long as the exciting radiation is unaltered. The phosphorescence occurs simultaneously with the fluorescence but, owing to its feebler intensity, it is only perceived when the fluorescence ceases. It also builds up more slowly than

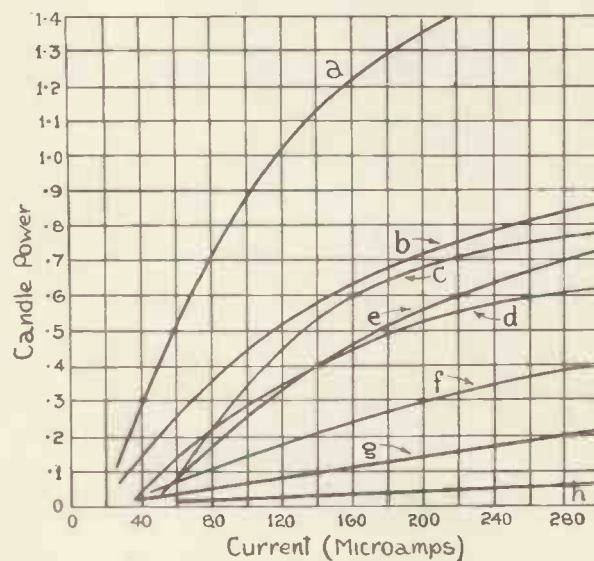

Fig. 2.—Curves obtained by maintaining voltage constant at 2,800 volts and varying current.

- (a) Preparation Z 23 (zinc sulphide and zinc cadmium sulphide).
- (b) Zinc sulphide U 36.
- (c) Zinc sulphide G 86.
- (d) Zinc-cadmium sulphide B 11.
- (e) Zinc-cadmium sulphide (foreign preparation).
- (f) Willemite.
- (g) Cadmium tungstate.
- (h) Zinc phosphate.

MANUFACTURE OF SCREEN COATINGS

display fluorescence of maximum intensity always exhibit much less phosphorescence. Many phosphorescent preparations do not give fluorescence of the maximum intensity obtainable.

Fluorescence and phosphorescence are, however, differently affected by various treatments. The most striking example of this is afforded by the extraordinary effect of the nickel "killer" on phosphorescence; this effect will be described later in the paper.

In the vast majority of practical applications of lumin-

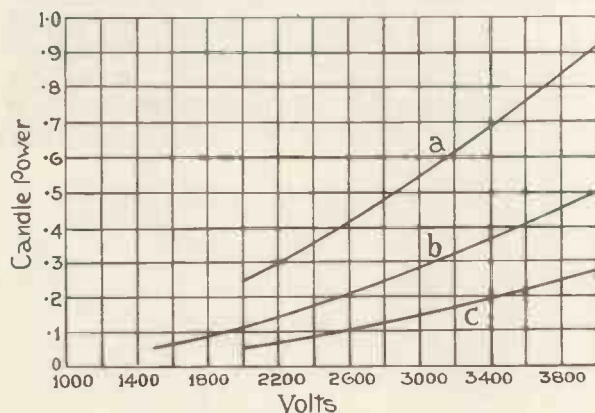

Fig. 3.—Curves obtained by photo-electric cell method. Current maintained at 100 microamps., voltage varied.
(a) Zinc sulphide G 86.
(b) Preparation Z 23 (zinc sulphide and zinc-cadmium sulphide).
(c) Zinc-cadmium sulphide (foreign preparation).

ous bodies, it is fluorescence which is desired, the phosphorescence being either of no interest or, more frequently, definitely prejudicial. There appear to be two types of phosphorescence exhibited by luminescent substances; these may be regarded respectively as directly and indirectly excited.

Phosphorescence or, as it is frequently termed, "lag" or afterglow, if of short duration (up to, say, 1,000 micro-seconds), is very well measured by the method described by Bedford and Puckle. Values of the time of phosphorescence for a number of different preparations determined by this method are given below:—

Material.	Duration of directly-excited phosphorescence.
Calcium tungstate	8 microsec.
Cadmium tungstate	8 microsec.
Willemite	2-8 millise.
Zinc phosphate	about 0.25 sec.
Zinc sulphide with nickel "killer"	Too small to be measured (fraction of 1 microsec.).

It should be noted that the duration of the phosphorescence in any particular substance varies with the exact method of preparation employed, and that zinc sulphide with nickel "killer" addition does not display any measurable phosphorescence.

In cases where the phosphorescence is of lengthy duration, i.e., minutes or hours, other methods have to be employed for its determination.

Manufacture and Characteristics of Luminescent Substances

The production of luminescent substances is a very highly specialised branch of inorganic chemistry. Extraordinary precautions are necessary in order to obtain the best results. For example, it is essential that the materials should be as free as possible from every trace of certain substances, notably certain metals, which act as "poisons" and very greatly diminish the intensity of light emitted. The amount of impurity which is prejudicial is in some cases so small that the materials have to be prepared under what might be termed "aseptic" conditions, similar to those necessary in bacteriological work, in order to ensure the absence of all undesirable impurities.

Certain substances, as, for example, calcium tungstate and cadmium tungstate, display their maximum luminescence when they are apparently perfectly pure; but in many cases, notably those of zinc sulphide and zinc-cadmium sulphide, zinc silicates, and zinc phosphates, very little luminescence is displayed unless an activator is present. The amount of the activator required is very small, generally about 1 in 10,000 to 1 in 100,000 parts by weight.

The majority of solid luminescent substances do not develop their special properties unless they are in crystalline form. The luminescent substances are therefore prepared in an extremely pure condition, the necessary phosphorogen is added, and the preparation is then heated to a high temperature either with or without flux, in order to induce the material to crystallise, after which the luminous properties become fully developed.

In certain cases, as, for example, the platinocyanides, the luminescent substance is water-soluble and

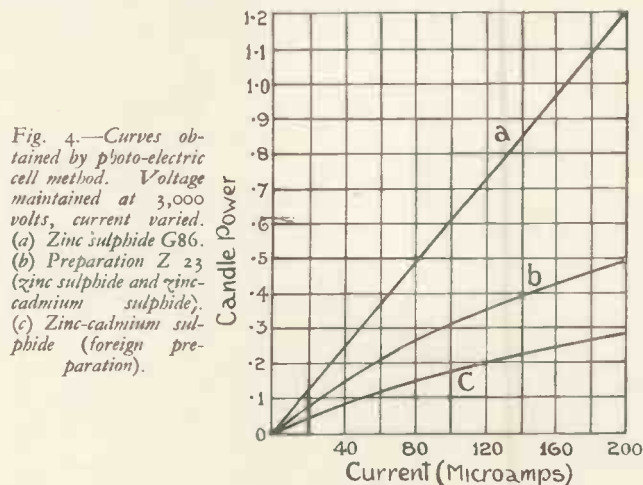

Fig. 4.—Curves obtained by photo-electric cell method. Voltage maintained at 3,000 volts, current varied.
(a) Zinc sulphide G86.
(b) Preparation Z 23 (zinc sulphide and zinc-cadmium sulphide).
(c) Zinc-cadmium sulphide (foreign preparation).

therefore can be crystallised from solution and is luminous without being heated. Heating would in fact destroy its luminescence.

Fluorescent Substances Employed

Large numbers of substances, both natural and artificial, exhibit luminescent properties under cathode-ray

LUMINESCENT MATERIALS

bombardment, but only a few have found practical application in cathode-ray tubes. The technique of manufacture of the latter precludes the use of many classes of substances; for example, as the tubes in the course of manufacture are heated to about 400° C., substances which would be damaged by such treatment cannot be employed. This naturally excludes bodies whose fluorescence depends upon the presence of water of

been largely or entirely superseded by special preparations of zinc sulphide and zinc-cadmium sulphide (see below), which are much more efficient.

(IV) *Zinc Phosphate*.—Zinc phosphate displays a red fluorescence and a directly-excited red phosphorescence. It finds some application in those instances in which a visible residual trace is required after the exciting beam has ceased to act on the screen.

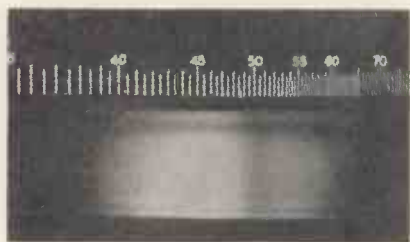

Fig. 5 (left).—Calcium tungstate. Exposure 5 min. Current 200μ A.

crystallisation, such as barium platino cyanide tetrahydrate.

The following are the principal substances which have been or are being employed for fluorescent screens in cathode ray tubes:—

(I) *Synthetic Willemite*.—This is an artificially produced zinc silicate which displays green fluorescence and some phosphorescence under cathode-ray bombardment. The material is specially sensitive to low-speed electrons corresponding to voltages of 250 to 300 volts.

(II) *Calcium Tungstate*.—The fluorescence of calcium tungstate is blue-violet in colour and very actinic, and it is for this reason that it has been employed for

Fig. 6.—Willemite. Exposure 4 min. Current 200μ A.

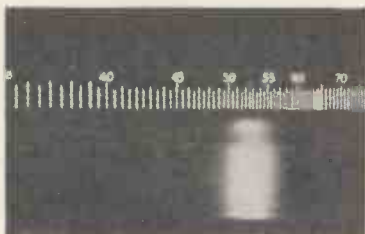

the past 30 years in the manufacture of intensifying screens for X-ray purposes. For the same reason, the substance is employed in cathode-ray tubes when a photographic record of the trace on the fluorescent screen is required.

(III) *Cadmium Tungstate*.—This substance has found application in cathode-ray tubes used for television owing to the fact that the fluorescence is of a very pale blue, so that the televised picture appears to be substantially black and white. This substance suffers from the drawback that high voltages have to be employed in order to produce a picture of adequate brilliancy.

Both calcium tungstate and cadmium tungstate have

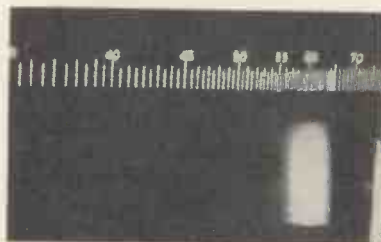

Fig. 7.—Zinc Phosphate. Exposure 3 min. Current 330μ A.

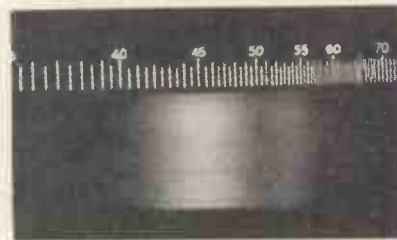

Fig. 8.—Zinc Sulphide U 36. Exposure 25 min. Current 50μ A.

(V) *Zinc Sulphide and Zinc-cadmium Sulphide*.—Various varieties of zinc sulphide and zinc-cadmium sulphide are by far the most useful fluorescent substances so far developed for cathode-ray tubes. As already stated, the use of the nickel "killer" has enabled the objectionable phosphorescence to be eliminated and, as will be seen from the authors' photometric measurements (Figs. 1-4), the brilliancy of fluorescence produced by these substances with a given voltage far transcends that obtainable with any other luminescent chemical.

Saturation

Fluorescent substances under cathode-ray bombard-

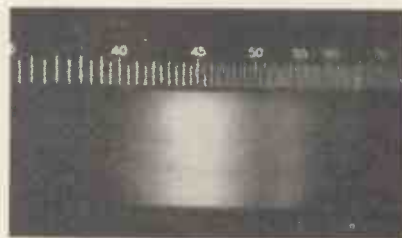

Fig. 9.—Zinc sulphide U 36. Exposure 40 sec. Current 200μ A.

ment reach a saturation point after which no increase in either current or voltage effects any increase in brightness. The point at which various preparations exhibit saturation varies greatly with the method of preparation employed. For example, certain varieties of zinc-cadmium sulphide exhibiting brilliant fluorescence at comparatively low voltages, saturate when the voltage is increased, whereas other preparations differing only very slightly, show increasing luminosity over a far greater range.

Saturation measurements have been made on a number of substances. The measurements were made by Mr. L. H. Bedford with a photo-electric photometer, and were of the following two kinds.

1) "*Raster*" Saturation.—In this type of saturation the size of the "raster" (i.e., the illuminated area covered by the scanning spot, or the scanning field) is progressively reduced without alteration of the size or the intensity of the spot. The standard conditions for these tests were 3,000 volts, 100 microamps., i.e., 0.3 watt in the beam. The raster size was reduced in steps from its normal value of approximately 80 mm.

(Continued on page 250)

The Short-wave Radio World

A Five-metre Transmitter and Receiver

ALTHOUGH the greatly increased popularity of the five-metre band has resulted in the use of transmitters, station operators who wish for maximum efficiency use a separate transmitter and receiver, although both may be housed in the same cabinet.

"Radio" has just issued a new rig

A Review of the Most Important Features of the World's Short-wave Literature

R.F. into the aerial. Owing to the fact that a 100,000 ohm leak is used in the grid circuit of the oscillator, no R.F. choke is needed. Typical values are given in the circuit, Fig. 1.

W6JYH has overcome this difficulty in quite a simple way. He has made an adaptor, as shown in Fig. 2, which consists of a 10-metre grid coil made up of four turns of 14-gauge wire on a 1-in. diameter former with a 1/4-in. gap between turns. It is coupled to an aerial coil of the same diameter as the grid coil but of two turns only.

The grid coil is mounted on the tun-

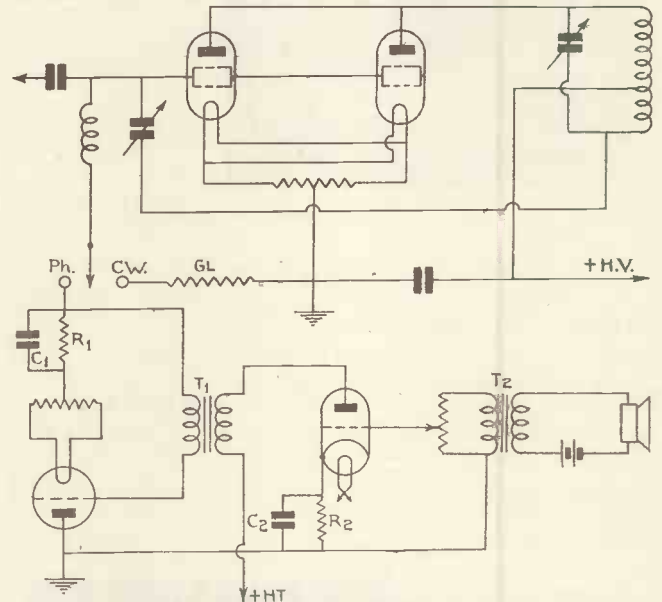
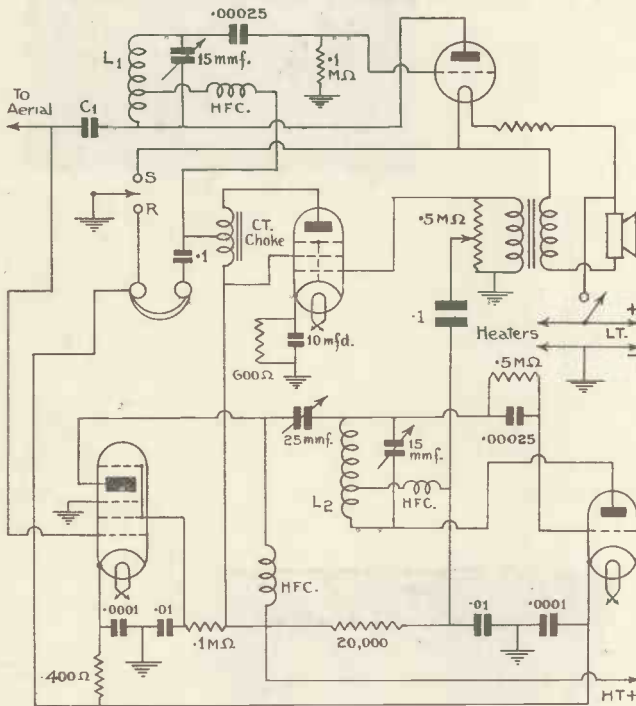

Fig. 1.—It would be a good point if all British amateurs used receivers of this type with a stage of speech frequency amplification as shown on the left.

Fig. 2.—Above is a circuit showing a novel way of grid leak modulating a pair of 46's. This idea is applicable to other valves.

of this type, the circuit of which is shown in Fig. 1. It is built in a 7-in. square case and embodies several interesting features. The send-receive switch is of the ordinary single-pole, double-throw snap type and as the receiver has a separate tuning system, the transmitter can be set at one fixed frequency. This enables aerial coupling to be greatly increased, with the result that with a given plate voltage the R.F. power into the aerial is more than doubled.

To prevent re-radiation the receiver section makes use of one stage of speech-frequency amplification. A resonant aerial is suggested, as this causes the grid circuit to be slightly tuned while the plate circuit is coupled to a superregen. detector by means of a 25-mfd. capacity. The valve in the detector circuit is of the AC/HL triode type and is resistance coupled to the modulator. The English equivalent to the modulator is an AC2/Pen, which drives the oscillator fully and with good quality.

In the transmitter section an oscillator valve of the 0-15-400 type is most effective, as it puts a high percentage of

Adapting a Superhet for Ten Metres

Since the 10-metre amateur-band has proved so consistent for D.X. work, many amateurs have gone over to this frequency. Unfortunately most of the commercial super-hets do not tune below 15 metres, so that some makeshift receiver has to be knocked up for the 10-metre band. This often accounts for

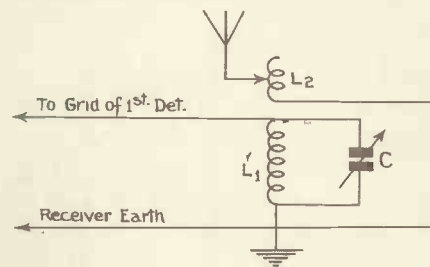

Fig. 3.—A super-het can easily be modified for 10-metre working with this simple circuit.

the poor reception by stations which normally do very well on the 14-Mc. and other bands.

ing condenser, one side of which is already earthed. A short grid lead is then taken on to the grid of the first valve in the super-het. The aerial is removed from the receiver and clipped on to the two-turn aerial coil.

To tune to the 10-metre band switch the super-het to 20 metres and then tune with the band-spread condenser. In this way the receiver is working off the harmonic of the 20-metre oscillator, and it will be found that the output on 10 metres will be almost as good as on 20 metres.

Grid-leak Modulation

Modulation by varying the grid leak resistance, using a valve as a leak, is not generally used, as it is inclined to give non-linear modulation. However, W9BUZ has worked out a good system of grid leak modulation for type 46's, as shown in Fig. 2. This system has an advantage over the usual grid bias modulation systems as it eliminates one transformer and does not require any bias supply. The R.F. section of the transmitter is conventional using a pair of 46's in the final stage but with the

Noise Silencing: Lower-power Transmitter

grid leak replaced by the modulator valve and its biasing resistance as shown in Fig. 3.

After experimenting with this arrangement it was found that the only valve which would give good quality as a modulator was the type 10. The characteristics of the 10 and 46's apparently compliment each other in such a way that while neither is linear by itself the results in aerial current plotted across grid voltage on the modulator forms a straight line which is almost perfect.

To put the arrangement into opera-

lar. However, in the current "QST" are given details of an alternative circuit for receivers having two I.F. stages which can be built in as an integral part of the receiver. The new circuit is almost self-explanatory and is shown in Fig. 4, the values for which are as follows:

C₃, .01-mfd.; C₇, .1-mfd.; C₈, .01-mfd.; C₂₁, 250-mmfd.; C₂₂, .1-mfd.; C₂₃, 50 mmfd.; R₅, 350/1,000 ohms; R₂₃, 20,000/500,000 ohms; R₂₄, 5,000 ohms; R₂₉, 100,000 ohms; R₃₁, 50,000 ohms; RFC, 20 milli-henry; T₄, single air-tuned diode coupling transformer.

sult of the simple calculation comes out close to a whole number. The frequency meter may have a coverage on any band so long as two harmonics can be heard. It is convenient to start at 1,750 or 3,500 kc. since harmonics will then appear at the low-frequency edges of the different bands.

A Two-stage Low-power Transmitter

The new R.F. pentodes of the low-wattage type can be used to advantage in a Tri-Tet circuit. Fig. 5 shows a very simple two-stage transmitter

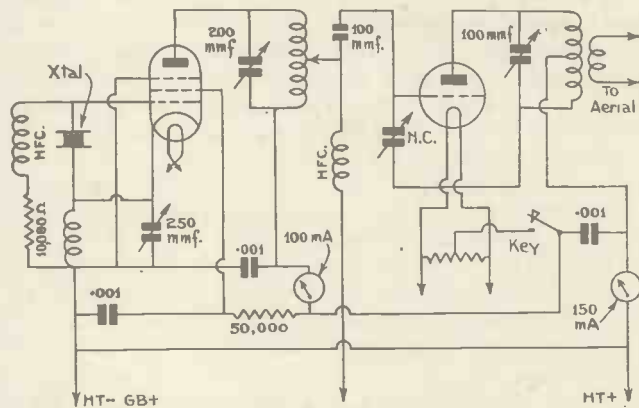
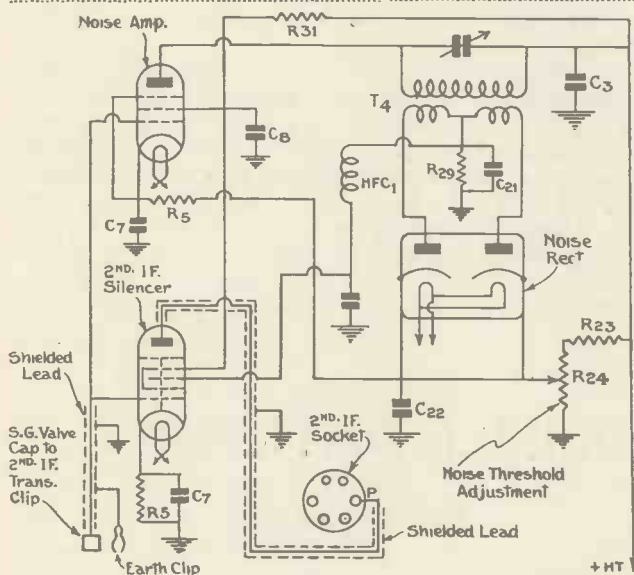

Fig. 4.—James Lamb of Q.S.T. evolved this interesting I.F. noise suppressor. This circuit is for supers with two I.F. stages.

Fig. 5.—The new low-power pentodes can be used in this arrangement to advantage. The Tri-Tet should be a type 59.

tion only two steps are necessary. First, with the SPDT switch in the C.W. position, tune for maximum aerial current. The output obtained at this point represents the power on the positive peaks of modulation and may be well in excess of the capabilities of the valve for C.W. operation.

Second, with the switch in the phone position adjust excitation until the aerial current is one-half of its former value. As always, the anode current of the modulated stage should be steady with modulation. Those interested in modulating other types of valves should follow the same procedure to determine proper oscillating conditions; that is a curve of aerial current against modulator grid voltage should be plotted to determine the linearity of the valve combination used.

Noise Silencing Units

Noise suppression in the I.F. circuits is now an accomplished fact thanks to the experimental work of James Lamb. The original idea, however, of making the noise silencing unit separate from the main receiver was not entirely popu-

Adjacent Harmonic Frequency Selection

W8DUO uses an original method of adjacent harmonic frequency selection for both transmission and reception. The problem of identifying the order of harmonic picked up from a calibrated frequency meter working on a low-frequency band is very much simplified by using this method. A calibrated frequency meter is used in the following manner.

Set the meter to 1,750 kc. and tune for a harmonic in the receiver under test. Leaving the receiver set at this point tune the frequency meter slowly higher in frequency until another signal is heard. For example, assume the second reading to be 1,842 kc. Subtract these figures, 1,842 - 1,750 giving 92. Divide the larger figure by the difference giving 1,842 divided by 92 equals 20.02. This result, approximately 20, is the number of the harmonic of the first frequency reading; that is, the 20th harmonic of 1,750 kc. or 35,000 kc.

Obviously the frequency meter must be read very carefully so that the re-

which can be used on any two wavebands with a single crystal. If all the coils are of the same inductance then the transmitter will be suitable for just one band, but by making the oscillator anode and P.A. tank coil tune to a harmonic, then the transmitter can be used on 20-metres with a 40-metre crystal or on 80 metres with a 160-metre crystal, just taking two examples.

By adjustment of H.T. and grid voltages almost any type of valve may be used in the P.A. stage. With 250 volts H.T. available a PX4 type of valve will work excellently.

All coils with the exception of the P.A. tank can be of the BCL plug-in type without loss of efficiency.

Hivac S.W. Valves

Hivac have now introduced three special short-wave receiving valves.

The approximate characteristics are as follows:—D210SW. Amplification factor 16, slope 1.35 m/a. per volt, price 5s. 6d.

SG220SW. Amplification factor 500, slope 1.5 m/a. per volt, price 12s. 6d.

PX230SW. Amplification factor 6.5, slope 1.5 m/a. per volt, price 12s.

THE BROADCASTING COMMITTEE'S REPORT

THE long-awaited Report of the Broadcasting Committee (Chairman, The Rt. Hon. the Viscount Ullswater, G.C.B.) was published on the eve of our going to press and we here present the summary of the recommendations made in the course of the Report.

We may say that the Report itself is a rather colourless document and leaves broadcasting very much as it found it. It makes a few recommendations which the Government and Parliament may or may not adopt, but chiefly it leaves well alone.

It extends the B.B.C.'s charter for ten years; makes some recommendations as to the method of filling vacancies arising in the staff of the B.B.C.; leaves minor issues and measures of domestic policy to the B.B.C.'s judgment; suggests that a selected Cabinet Minister in the House of Commons should be responsible for broad questions of policy with the right of veto over programmes, technical control remaining with the Postmaster-General. It leaves the licence fee at 10/-, but suggests that a larger portion should go to the B.B.C. It recommends that direct advertisement should remain excluded from the broadcast service, that the inclusion of sponsored items in television broadcasting be carefully regulated, and that something should be done to prevent spon-

sored programmes being broadcast from foreign stations.

One of its few definite recommendations of any importance is that the ownership and operation of relay exchanges should pass to the Post Office and that the control of relay programmes go to the B.B.C. It recommends that the possibility of designing and putting on sale a standard broadcasting receiving set at a low fixed price be examined and that local authorities should be empowered to deal with the annoyance due to the misuse of loudspeakers.

And that is all. The Report could scarcely have contained less.

On television it has hardly anything to say except to draw attention to the work undertaken by the B.B.C. acting under the Report of the Television Committee issued a year ago. It has a word to say about television finance and points out that what has been entrusted to the B.B.C. is the conduct of "a public broadcast service of television" and that other applications of television remain entirely under the control of the Postmaster-General.

For the sake of record, we reprint paragraphs 124 to 129 inclusive of the Report, covering all that the Committee has to say on the subject of television.

SUMMARY OF RECOMMENDATIONS

Charter

That, in view of the wide-spread approval of the broadcasting service in this country, in which we fully concur, the Charter of the British Broadcasting Corporation should be extended for a term of ten years from January 1, 1937.

Governors

That the Governors should not be specialists or representatives of particular interests or localities; and that the outlook of the younger generation should be reflected in some of the appointments made.

That the number of Governors should be increased to seven; that they should be nominated by the Crown, on the recommendation of the Prime Minister; that the normal term of office should be five years, and a retiring Governor should not be re-nominated; that the salary of the Chairman should be £3,000, and of each other member £1,000.

Regions

That the present policy of decentralisation and of including a good proportion of regional programme material should be continued;

That Wales should, as soon as pos-

sible, be constituted as a distinct broadcasting region.

Staff Matters

That major staff vacancies should be advertised and appointments made on the recommendation of a specially constituted selection board.

That all facilities should be given for any representative organisation which the staff may wish to set up.

That the programme staff should abstain from any prominent part in public controversy, but that the private lives of the staff should be free from control by the B.B.C.

That a critic of the B.B.C. should not be disqualified from broadcasting.

Advisory Council and Committees

That the General Advisory Council should continue and there should be a general Advisory Committee in each Region as well as a full system of central and regional specialist Advisory Committees.

That the term of appointment should be four years but there should be no bar against re-appointment.

That the Committees should be as widely representative of varied interests as possible, so that not only experts but the listening public also and

the younger generation in particular should find a place on them.

Control

That minor issues, measures of domestic policy, and matters of day-to-day management should be left to the free judgment of the Corporation.

That the Minister responsible in respect of broad questions of policy and culture should be a selected Cabinet Minister in the House of Commons, free from heavy Departmental responsibilities and preferably a senior member of the Government; that this Minister should have the right of veto over programmes, and the duty of defending the Broadcasting Estimates in Parliament; but that technical control should remain with the Postmaster General.

That the B.B.C. should have the right to state when it is broadcasting an announcement at the request of a Government Department.

That the right of direct Government control in case of major national emergency should be maintained.

Finance

That the licence fee should remain at 10s.

(Continued on page 248)

IT PAYS TO BUY THE BEST



ADJUSTABLE BRACKET.
A strong baseboard bracket for mounting components controlled by an extension rod. Has adjustable (2 1/2" to 3 1/2") slide of DL-9 H.F. insulation. No. 1007. Price 1/6.



EXTENSION CONTROL OUTFIT.
Ample length adjustment is obtainable with the 4" non-warp precision-drawn insulating tube and 3" brass rod provided in this outfit. Complete with panel-bush and nut. No. 1008. Price 1/3.



BAR INSULATOR.
An ultra high frequency insulator or strain or spacer purposes, made from Frequentite. Slotted ends for feeders with 2" spacing. No. 1017. Price 4 1/2d. each.



ULTRA SHORT-WAVE H.F. CHOKES.
These chokes are single layer space wound on DL-9 formers, and have an exceedingly low self-capacity. 2 1/2-10 metres. No. 1011. D.C. Resistance 1.3 ohms. Price 1/3. No. 1021. D.C. Resistance 0.4 ohms. Price 1/3.



INTERCHANGEABLE COILS
New low loss formers of DL-9 high-frequency insulation. Rigidly made and each coil matched. First-class results assured. 4-pin coils have two windings, 6-pin three windings. No. 959 6-pin Set of 4 12-170 metres Price 16/- No. 952 4-pin " " " " Price 14/-



MIDGET INSULATOR.
Made from Frequentite for high frequency work, with N.P. metal parts. 1" overall height. No. 1019. Price 4 1/2d. each.



UNIVERSAL S.W. VALVEHOLDER.
A low loss holder for above or below baseboard use. The valve enters the contacts from either side. There is no measurable increase of self-capacity to that already in the valve base. DL-9. H.F. dielectric, one-piece noiseless contacts. No. 1015. 4-pin, 1/3. No. 1016. 5-pin, 1/5. No. 1024. 7-pin, 1/8.



MIDGET CONDENSER.
A small-size variable condenser for S.W. circuits. Soldered moving and rotor vanes, with DL-9 H.F. insulation. With knob and scale, 3-65 m.mfd. No. 1013. Price 4/3.



FLEXIBLE COUPLER
Free from back-lash but very flexible, this coupler banishes alignment troubles, DL-9. H.F. insulation. For 1/2" spindles. No. 1009. Price 1/6

IMPROVED MICRODENSER No. 900



For ultra H.F. and general S.W. use CALIT insulation, low series resistance, noiseless movement, extended 1/2" spindle for ganging. 20 m.mfd., 3/9d.; 40 m.mfd., 4/3d.; 100 m.mfd., 5/-.

IMPROVED SCIENTIFIC CONDENSER No. 942.



A Condenser representing advanced technical H.F. design, CALIT insulation, all brass construction, soldered vanes, noiseless movement, extended 1/2" spindle for ganging. 180 m.mfd., 7/6d.

EDDYSTONE SHORT WAVE COMPONENTS

STRATTON & CO., LTD. Bromsgrove Street, BIRMINGHAM. LONDON Service Depot: Webb's Radio Stores, 14 Soho Street, Oxford Street, W.



Di-pole Balanced Aerial Kit



DE LUXE MODEL
PRICE **27/6** COMPLETE

ALL-WAVE RECEIVERS GIVE MUCH FINER PERFORMANCES WHEN THIS SPECIALLY-DESIGNED "PILOT" ALL-WAVE AERIAL KIT IS USED.

The effects of Man-made or Ethereal statics are greatly reduced owing to the "Pilot" low-impedance Down-Lead.

All radio energy reaching the "Pilot" Aerial is passed to the set without appreciable loss of power.

The "Pilot" Transformer included in the equipment still further "boosts" incoming signals and increases sensitivity and selectivity.

A switch is provided on the Trans-

former for changing from normal broadcast to ultra-short or short-wave reception.

The "Pilot" Aerial is equally effective when used either as a Balanced Doublet type, "L" type or Bent Doublet (right angle) aerial system.

Full protection is supplied by two "Pilot" lightning arresters. Erection of aerial is simple. Installation instructions with every kit.

OBTAINABLE THROUGH YOUR LOCAL DEALERS

ALL ENQUIRIES TO MAIN DISTRIBUTORS FOR GREAT BRITAIN

STREAMLINE RADIO LTD., 146, THEOBALDS RD., LONDON, W.C.1

Telegrams: ALWAYBAND-HOLB-LONDON

Telephone: HOLborn 3252

BROADCASTING COMMITTEE AND TELEVISION (Contd. from p. 246)

That the share of licence revenue allocated to the Post Office should be a percentage to cover costs, reviewed every two years.

That the share of the remaining net revenue to be allocated to the B.B.C., for purposes other than Television, should be not less than 75 per cent. of current receipts.

That the balance should be regarded as potentially available for the needs of broadcasting, and that when all needs have been met any surplus remaining may equitably be assigned to the State.

That the Exchequer share for the year 1936 should be limited to £1,050,000 (exclusive of the Income Tax payable by the B.B.C.)

That payments to authors and composers should be generous, and that fees payable in respect of copyright, etc., should be settled, in default of agreement, by arbitration.

That capital expenditure should be defrayed from surpluses of revenue over current expenditure, but the limit of short-term borrowing might be raised to £1,000,000; and that major items of contemplated capital expenditure should be stated when the Broadcasting Estimates are presented to Parliament.

That current expenditure should be shown in a limited degree of detail in the Annual Account, and supplementary particulars be given in the Annual Report.

Editorial Comments

That, continuing present practice,

the B.B.C. should refrain from broadcasting its own opinions on current affairs.

News

That the broadcast news service should be unbiased and dispassionate; that the B.B.C. should have a free choice as to the sources and methods of obtaining news; that existing arrangements are satisfactory but there should be no bar to variations for the purpose of meeting such demands as the future may bring.

Advertisement

That direct advertisement should remain excluded from the broadcast service.

That "sponsored" items need not be entirely excluded, especially in the earliest stages of television broadcasting, but that their admission should be carefully regulated by the B.B.C.

That the responsible departments should take all the steps which are within their power with a view to preventing the broadcasting from foreign stations of advertisement programmes, intended for this country, to which objection has been taken.

Empire Broadcasting

That the Empire service should receive express authorisation and should be fostered and developed; and that the appropriate use of languages other than English should be encouraged.

Television Broadcasting

That television broadcasting should be expressly authorised.

That its finance for two years ahead should be reconsidered by the Television Advisory Committee in the autumn of 1936.

That television should have a claim upon a proportion of the surplus remaining after deduction of 75 per cent. of the net revenue from licences.

Relay Exchanges

That the ownership and operation of relay exchanges and the technical development of wire broadcasting in general should be undertaken by the Post Office, and the control of relayed programmes by the B.B.C.

Publications

That no change is called for in respect of B.B.C. publications.

Electrical Interference

That the technical investigation of interference with broadcasting reception should be expedited, and compulsory limiting powers sought if necessary.

Receiving Sets

That the B.B.C. and the wireless trade should jointly examine the possibility of designing and putting on sale at a low fixed price a standard receiving set.

Loud Speaker Nuisance

That local authorities should take powers in approved form to deal with annoyance due to the persistent misuse of loud speakers, etc.

(Signed) ULLSWATER (Chairman).
J. J. ASTOR
C. R. ATTLEE
CLEMENT DAVIES
ELTON
WILLIAM MCLINTOCK
STELLA READING
SELSDON
GRAHAM WHITE

THE REPORT'S REFERENCES TO TELEVISION

FINANCE POSITION TO BE REVIEWED IN THE AUTUMN

The field of television broadcasting has recently been reviewed by a committee under the chairmanship of Lord Selsdon, whose Report was presented to Parliament in January, 1935, and approved by the Government. That Report shows that licences for research and experimental work had been issued for some time past, with the intention that as soon as public transmissions were justified the B.B.C. should afford facilities for a trial service on a limited scale, and that since the autumn of 1929 experimental transmissions have been given by the Baird Company both independently and in conjunction with the B.B.C. During the past year television broadcasts

occupied two periods weekly (of 30 to 45 minutes), with accompanying sound on a separate wavelength. These broadcasts have now been discontinued in view of the impending introduction of a public service.

In accordance with recommendations in the same Report, the Government has decided that the B.B.C. shall be charged with the duty of conducting a television broadcasting service, and the Television Advisory Committee has been constituted, under the chairmanship of Lord Selsdon, to assist you and the Corporation in the "planning and guiding" of this new service.

You are therefore aware of the progress up to date, and we accordingly

content ourselves with recording that the Alexandra Palace has been selected as the site for the London station, from which transmissions are to take place with apparatus supplied by Baird Television, Ltd., and the Marconi-E.M.I. Television Company, Ltd., respectively, under more or less competitive conditions; that contracts for the supply of this apparatus have been placed; that installation is in progress; and that it is hoped to start test transmissions in March, to be followed by a regular public service as soon as the tests are completed. It will presumably be desirable to empower the B.B.C. to broadcast visual images, as well as sound.

As regards finance, we find our-

selves in the same difficulty which faced the Television Committee in their Report, namely, that at this stage it is wholly impossible to forecast over a number of years the expenditure likely to be incurred upon this service, since that depends upon a host of unknown factors. We are, however, informed that in the opinion of the Television Advisory Committee the cost of providing the proposed London station and a service therefrom up to December 31, 1936, is likely to coincide approximately with the estimate of £180,000 given in the Television's Committee's Report. We can therefore only recommend that the position should again be considered in the autumn of 1936, when the Advisory Committee will have had the experience of some six months' working of the London station and when accordingly they hope to be in a position to forecast the probable expenditure up till the end of 1938. That would therefore seem to be a more appropriate moment to determine the general methods of finance and, in particular, whether any special licence fee is to be imposed upon the users of this service or whether it is to continue to be "thrown in" with the ordinary licence. On this point, we will only observe that, while the imposition of a special licence has considerable logical justification, it is evident that, at least for some years, it cannot possibly provide more than a fraction of the cost of the service.

Finance

We may, however, add that, in recommending that the balance of wireless licence revenue accruing to the Exchequer should be regarded as potentially available in future years for the purposes of broadcasting, we had in view, apart from other possible contingencies, that television broadcasting is likely to require increasing funds, and that a further proportion of the net receiving licence revenue might well be used towards this purpose, over and above the 75 per cent. now recommended to be utilised for sound broadcasting. We should all realise that it will be obvious that no hard and fast line can be drawn between television broadcasting and ordinary broadcasting expenditure, since with the development of the former a considerable and increasing portion of

(Continued on page 256)



HIVAC
THE SCIENTIFIC
VALVE
BRITISH MADE

FOR SHORT WAVES

Time and again, designers have shown a preference for HIVAC valves when making their choice for inclusion in short-wave receivers, adaptors or converters. Because of their rigidity of construction, their excellent performance is consistently maintained.

Hivac are specified for the
U.H.F. 112-28 Mc SUPER-HET
and for the
BATTERY FREQUENCY METER
described in this issue.

Mains Type.¹ Battery Type.
AC/HL (Met.) S.G. 215.
9/6 10/6

★ **IMPORTANT NOTICE**

Hivac have developed a special range of 2-volt Battery valves for Short-Wave work.
Send a P.C. for Leaflet "S/W-7"

High Vacuum Valve Co., Ltd., 113-117 Farringdon Road, London, E.C.1

It is a fact,

that over 80 per cent. of the manufacturers of All-Wave, Short and Ultra-Short Wave Receivers, Converters and Adaptors employ one or more of the Clix range of Perfect Contact Components.

Again, no matter which British Radio or Television journal you pick up, you will invariably find that "Clix" are specified in some or all the apparatus described for the benefit of home constructors.

We ask you to accept these facts as proof of the perfect service which you will secure by seeing that "Clix" products are used in any radio apparatus which you may buy or build.

CLIX ARE SPECIFIED

for the following apparatus described in this issue. The "U.H.F. 112-28 Mc. Super-Het." The "Battery Frequency Meter." The "Five Metre Transmitter."

CLIX VALVEHOLDERS.

Standard Type. 4-pin 8d., 5-pin 9d., 7-pin 1/-
Ceramic S/W Type. 5-pin 11d., 7-pin 1/2

CLIX INSULATED SOCKETS.

Completely insulated for use on
metal chassis. 2½d.
Clix Solid Plugs for above 2d. each

CLIX WANDER PLUGS.

For H.T. or G.B. 1½d. each

CLIX SPADE TERMINALS.

Small 1½d. Large 2d.

FOLDER "T.S.W." FREE ON REQUEST

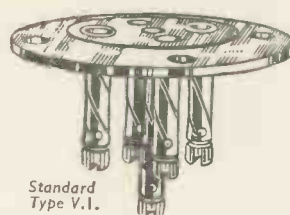

Standard Type V.1.

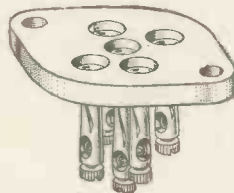

Low-loss Ceramic Type V.5.

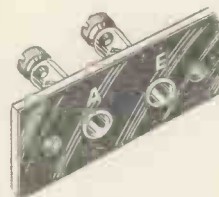

LECTRO LINX LIMITED,
79a, ROCHESTER ROW, LONDON, S.W.1 **CLIX**

"Fluorescent Screens for Cathode-ray Tubes."

(Continued from page 243).

× 60 mm. to approximately 30 mm. × 18 mm., representing a variation of raster rating of 0.0062-0.55 watt per cm². None of the screen materials showed saturation even under these high intensities, which are enormously higher than anything contemplated in television; for the latter, a maximum raster rating would be of the order of 0.01 watt per cm².

(II) *Spot Saturation*.—In order to test for spot saturation, the raster was maintained at its normal size whilst the size of the spot was varied without alteration of the ray current and voltage. It was not possible to make accurate measurements, as it was impracticable to determine accurately the size of the spot in its focused condition. It may be assumed, however, that the spot area under the standard conditions mentioned would be of the order of 1 mm²; the spot rating in the focused condition would therefore be 30 watts per mm². For an increase in area of some 25 times, an increase in luminosity of the order of 35 per cent. was observed. This indicates that the spot is only slightly supersaturated.

Proportion of Light Transmitted through the Screen

The values of the illumination of the screen at the surface upon which the electrons impinge, and at the surface next the glass, are not the same. The difference will depend upon the thickness of the screen, the transparency of the fluorescent material, its grain size, and the nature of the medium employed for fixing the material to the glass. The surface upon which the cathode-rays impinge is always brighter than the surface next to the glass, which is the one upon which fluorescent effects are observed. If a reflector of white paper is placed upon the surface of the glass, the amount of light emitted from the inner surface is again considerably increased. This illumination is equal to the total amount of light emitted less that lost by absorption in the glass and by imperfect reflection by the paper surface.

Colour

The colour of fluorescence is of considerable importance in television. Brilliantly coloured images do not make a general appeal. An image which is black and white, or nearly so, is preferred for general purposes. A very slight amount of warm tone such as pink, yellow, or sepia, is not so objectionable, but a greenish-white tint is not acceptable as it gives the picture a very cold appearance. It should be noted that the colour of a picture is its colour at low intensity. The bright portions are always substantially white in appearance. As high intensity of the raster, preparation U 36 appears to be quite white, but the picture as a whole displays a pale bluish-green tint.

Zinc sulphide and zinc-cadmium sulphide can now be so prepared as to emit fluorescent light of practically any colour. This is effected by varying the phosphorogen employed in the preparation of the substance and also the relative proportions of zinc sulphide and zinc-cadmium sulphide present in the preparation. For example, zinc sulphide R 2 containing copper phosphorogen exhibits a brilliant blue-green fluorescence. If silver is employed as phosphorogen, however, the fluorescence

is blue or blue-violet. If varying proportions of cadmium sulphide are added to zinc sulphide containing copper as phosphorogen, the colour of fluorescence can be varied from red through orange and yellow to green. Cadmium sulphide by itself is not luminescent, but it crystallises isomorphously with zinc sulphide and acts as a colour filter, as well as modifying the character of the luminescence.

Production of White Fluorescence

Preparations displaying white fluorescence can be obtained by mixing together two or more fluorescent substances displaying highly coloured fluorescence, the colours being selected so that a white is obtained; as, for example, by combining blue and a reddish-orange fluorescence. This method was employed by the authors a number of years ago for the production of compositions which would display white fluorescence when stimulated by ultra-violet radiation.

This method of obtaining white fluorescence is sometimes open to the objection that the spectral response (see below) of the luminescent substance varies with the intensity of the current. Certain mixtures which are white at any particular voltage will therefore probably appear somewhat coloured when the current intensity is altered to any considerable extent, although this does not appear to be the case with mixtures of zinc sulphide and zinc-cadmium sulphide.

Up till quite recently, cadmium tungstate was the only substance the fluorescence of which was only slightly coloured. It is actually pale blue. As shown in Figs. 1 and 2, cadmium tungstate is very inefficient compared with zinc sulphide, and it is therefore obvious that if a zinc-sulphide preparation could be produced displaying white fluorescence, this would be of interest. The authors have developed a zinc sulphide of this nature, U.36, the colour of fluorescence of which is substantially white.

The spectra of fluorescence of various preparations are given in Figs. 5 to 9. The relatively clear band 4900-5100 Å on all the spectra is a characteristic of the photographic emulsion, which does not respond well to light of this wavelength.

The spectrograms were made at different values of current density, in order to demonstrate the effect of this quantity upon the colour of emission.

It will be observed that the fluorescent spectrum of the various substances in each case consists of one or more bands. In the case of preparations in which only one phosphorogen is present, as a general rule the fluorescent spectrum consists of one band only. If more than one phosphorogen is present, then another band usually makes its appearance.

Mixtures of fluorescent substances also give two or more bands which coalesce into a continuous spectrum if the mixtures have been adjusted so that the light of the fluorescent mixture is white. The spectra of the zinc-sulphide preparation G86 and B11 are complementary, and thus a mixture of these two preparations should and does give a continuous spectrum.

The limits of the bands for the various substances examined are as follows:—

Cadmium tungstate.—A well-defined band 3900-4990Å, and a slightly-defined band 5200-6000Å.

Willemite.—A well-defined band 4900-5500 Å.

(Continued on page 252).

TAKE THE
DESIGNER'S
TIP!

ERIE RESISTORS
SPECIFIED FOR
The
U.H.F. SUPERHET
described in this issue

Insist on ERIE RESISTORS

It's not by chance that designer and manufacturers alike use Eries. It's because they are the best for the job. An important factor is their consistency and inherent stability. Insist on Eries. See that the resistors you buy bear the genuine Erie identifying label.



1/- Per Watt in all Values. Each resistor colour-coded, labelled and Guaranteed.



Insist on the ERIE Volume Control



3/6
or with
built-in
mains
switch
5/-

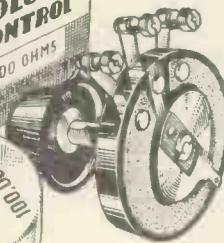

Whatever your set fit the Erie Variable Resistance. With the bonehard Erie resistance element and Erie precision construction, it is a definite improvement on everything else of its kind. Contact is smooth and positive; there are no hop-off noises; its absolutely noiseless efficiency is permanent. Made in all values, 5,000 ohms to 2 megohms. At all dealers.

THE RADIO RESISTOR CO. LIMITED
1, Golden Square, Piccadilly Circus, London, W.1

Specified by 'TELEVISION'

for the U.H.F
112-28 Mc Superhet



TYPE U.H.F. 8

Output 200 v., tapped 155 v. 200 m.a. For H.T.8 Westinghouse rectifier. Two windings each 4 v. centre tapped, 4 amps.

PRICE 35/-

Once more, the technical staff of "Television" show their faith in Savage mains transformers by specifying them for an important new set. Whether you decide to build the U.H.F. 112-28 Mc. Superhet or not, this is a lead worth following. Because of their good design, accuracy and reliability, Savage transformers and chokes are the first choice of all knowledgeable radio and television engineers.

Send for standard list (T3) to-day or ask us to quote to your specification.



W BRYAN
SAVAGE
LIMITED.

Westmoreland Road, Stanmore, Middlesex
(Adjoining Queensbury Met. Station)
Telephone: COLindale 7131 (3 lines)

" Fluorescent Screens for Cathode-ray Tubes "

(Continued from page 250).

Zinc phosphate.—A well-defined band 5800-6400 A.
Zinc sulphide, U 36.—A preparation giving substantially white fluorescence; the first band is 4200-5000 A, then there is a slight break, and the band continues (5200-5600 A).

Zinc sulphide, G 86.—The band of this preparation extends into the ultra-violet. It starts at 3700 A, is well defined at 4000 A, and continues to 4800 A.

Zinc sulphide, B 7.—This preparation gives a fairly continuous spectrum from 4600 A to 6500 A, but there is not much radiation at 5000-5200 A and 6300-6400 A.

Zinc sulphide, B 11.—A band extends from 4300 A to 6400 A with slightly lighter patches at 5700-5800 A and 4800-5000 A.

Mixture (Z 23) of G 86 and B 11.—This gives practically a continuous spectrum extending from 39000 A to 6600 A. The falling-off around 5000 A is due, as stated above, to the characteristics of the photographic emulsion.

Method of Coating the Fluorescent Screen

Fluorescent powders are distributed upon the base of the tube by coating the latter with an adhesive substance and blowing the fluorescent powder on to the adhesive surface, the surplus powder which does not stick being removed by shaking. Alkaline silicates are most commonly employed as the adhesive substance, as, unless they are present in excess, these materials

are without detrimental action upon the fluorescence. Potassium silicate is preferred to sodium silicate by some workers, and in either case the preparation should preferably be low in alkali content.

It is important that the amount of adhesive employed should be as low as possible, so that in effect the fluorescent particles are simply anchored in position by attachment at one spot of their surface. If excess of silicate is present, this can react with the fluorescent materials employed, with resulting degradation of their luminescent qualities.

Efficiency of Luminescence

The efficiency of luminescence of fluorescent bodies excited by cathode radiation compares favourably with that of light obtained by means of increase of temperature, as in ordinary electric lighting. In the case of one preparation the efficiency of illumination is about 1.85 candle-power per watt of energy input.

The intrinsic brightness of the scanning spot which is produced by a cathode-ray beam of very high intensity is very great. In the case of a television transmitting tube the scanning spot is 0.3 mm. in diameter and has a candle-power of 1.2. Hence its luminosity is 17 candles per mm². The intensity of illumination of the filament in a tungsten vacuum lamp is 1.25 candles per mm²., and in the case of the gasfilled lamp 5 to 13 candles per mm²., according to the type and size of the lamp. The intrinsic illumination of the scanning spot is thus higher, but it is still very much below that of the arc crater of a plain carbon arc, which is of the order of 170 candles per mm².



Illustration of
MERVYN 42/- CONVERTER-ADAPTER 13-55 METRES

ULTRA SHORT

7 and 13-55 metres.

Suitable for Television sound and present 7.75 metre broadcasts. Pre-selector Triode Heptode converter for A.C. mains with filament transformer and all coils. Price assembled in cabinet 70/,- valve extra.

H.D. TELEVISION

3,500 V. H.T. UNITS FOR CATHODE RAY TUBE

Cadmium plated steel case. High vacuum valve rectifier. Assembled and tested. Inclusive price **£6**

7 METRE VISION SUPERHET

Tested. Wide Band. Single knob control. 8 valves. Synchronising stage. Complete less cabinet **£16 10 0**

DOUBLE TIME BASE KIT £6 10 0

Full details of 1936 Faraday All-wave Receiver now available.

Further information in descriptive Leaflets T.2 Free

THE MERVYN SOUND & VISION CO., LTD.
4, HOLBORN PLACE, LONDON, W.C.1
Telephone: HOL. 7709

PIEZO QUARTZ CRYSTALS



1.7mc, 3.5mc, and 7.0mc. Amateur bands

Power Type Standard Type
£1 post free **15/-** post free

Ground to within 5 Kcs. of your specified frequency, and supplied complete with official certificate of frequency.

CRYSTAL HOLDERS

Type A, Open Electrodes, 4s. 6d. post free.
Type B, Totally enclosed and dustproof, 8s. 6d. post free.

Send a 1½d. stamp to-day, for our new 1936 catalogue of short wave transmitter and receiver components.

THE QUARTZ CRYSTAL CO., LTD.,
63 & 71, KINGSTON ROAD, NEW MALDEN, SURREY
Telephone: MALDEN 0334.

TELEVISION.

A NEW COURSE OF INSTRUCTION.

We have pleasure in announcing that our new "Television" Course has met with remarkable success. The enormous demand for the Course has shown, beyond any shadow of doubt, that it fills that long-felt need which we anticipated when we went to such trouble and expense in its preparation.

We shall be happy to send full details of this special "Television" Course on request. Particulars are also available of other Courses in all branches of **Wireless, Television, Talking Picture Engineering, etc.**, and of the easiest way in which to prepare for the **A.M.I.E.E., A.M.I.W.T., A.M.I.R.E., etc.**, Examinations.

We teach by correspondence, and guarantee **"NO PASS—NO FEE."** Our Technical Consultant is Professor A. M. Low.

Send for full particulars to-day. Free and without obligation.

THE BRITISH INSTITUTE OF ENGINEERING TECHNOLOGY,
Recently removed to greatly enlarged premises at
337, SHAKESPEARE HOUSE, 17/19, STRATFORD PLACE, LONDON, W.1.

TELEVISION AND SHORT-WAVE WORLD KITS

ALL PARTS EXACTLY TO "TELEVISION" SPECIFICATION.
ALL OR ANY, OF THE COMPONENTS SUPPLIED AS REQUIRED.

ULTRA SHORT-WAVE SUPERHET

COMPLETE KIT OF PARTS, including Chassis, Panel, 6 Screen Boxes with Lids, and 5 Valve Screens ... £15 0 0.
8 Specified Valves, £6 5 0 extra.

1 Scientific Chassis & Panel ... s. d. 19 0	2 Scientific H.F. Chokes ... s. d. 1 6
6 Scientific Boxes with Lids ... 24 0	1 Eddystone 982 H.F. Choke ... 5 0
1 Dubilier 0281 8mF. Condenser ... 5 6	1 Sound Sales 30 L.F. Choke ... 14 0
2 Dubilier LSA9203 4mF. " ... 16 0	1 Polar Micro-Drive Dial ... 7 9
4 B.T.S. .00005mF. Air " ... 13 0	4 Bulgin K58 Knobs & IP8 Scales 3 8
1 Bulgin SW85 .00003mF. Trimmer ... 3 0	8 Clix Ceramic Valve Holders ... 6 4
2 Dubilier 665.0003mF. Con'srs. 1 0	9 Plugs, Terminals, etc. ... 2 8
4 Dubilier 670 .002mF. " ... 5 0	1 Westinghouse HT8 Rectifier 18 6
1 Dubilier 670 .01mF. " ... 2 0	19 Erie Fixed Resistances ... 19 0
3 Dubilier 4511 .01mF. " ... 3 0	3 Reliance Potentiometers ... 14 3
5 Dubilier 4513 .1mF. " ... 6 8	Sundries as specified ... 17 2
3 Eddystone 20m-mF. Microdrs. 11 3	1 Bulgin S80 Switch ... 1 6
1 Eddystone 40m-mF. Microdrs. 4 3	1 Bulgin S88 Switch ... 2 6
4 Eddystone 1020 4-turn Coils ... 6 0	1 Eddystone 1037 3-stage IF unit 25 6
1 Scientific Beat Freq. Coil ... 1 6	1 Savage special Mains Transfr. 35 0
	5 Colvern Valve Screens ... 13 9

SELF-CONTAINED 5-m. TRANSMITTER
COMPLETE KIT OF PARTS (as listed) including Chassis and Panel, £8 13 0.
4 Specified Valves, 66/- extra.

FREQUENCY METERS

Quotations for complete kits of parts for both the Battery Model and the A.C. Model, upon application.

All orders over 5/- postage free.

SATISFACTION GUARANTEED.

Scientific Supply Stores (Wireless) Ltd.,
126, Newington Causeway, London, S.E.1. 'Phone: HOP. 1800.

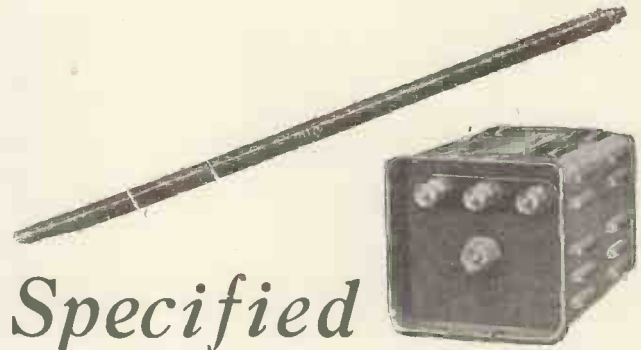

Specified

again and again on account of their reliability and efficiency, Westinghouse Metal Rectifiers continue to justify the faith which designers and users place in them.

The H.T. units are old friends, and we continually receive letters upholding our claim that the metal rectifier is, for all practical purposes, everlasting. Some have now been in continuous use for over 8 years and still show no appreciable sign of deterioration.

The "H" type unit is a newcomer. Whilst retaining the reliable characteristics of the H.T. units, it has been expressly designed for providing high voltages at low currents such as are needed for cathode ray tubes, etc.

Full details of all types of Westinghouse Metal Rectifier suitable for radio use are given in our booklet "THE ALL-METAL WAY, 1936," price 3d. The attached coupon will bring you a copy.



METAL RECTIFIERS

COUPON

Westinghouse Brake & Signal Co., Ltd.,
82, York Road, King's Cross, London, N.1.

Please send me a copy of "THE ALL-METAL WAY, 1936," for which I enclose 3d. in stamps.

Name

Address

T. 4.36.

G.2.N.O 11, LICHFIELD ST., WOLVERHAMPTON

The Radio Amateur's Paradise

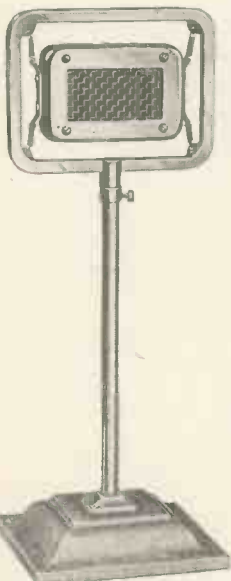

Here are a few selected lines from our stock list.

- 2 N.O.'s **TRANSVERSE MIKE.**
Adjustable Table Stand. Chromium finish ... 32/6
- McELROY Bug Keys** ... 42/-
- PEAK 2-STAGE PRE-SELECTOR.**
With Continental Tubes £6 10s.
With R.C.A. Tubes £7 5s.
- 10 - METRE HAMMARLUND COILS.** Per pair ... 18/-
- "AMATEUR" THREE-VALVE S.W.** Battery Receiver Complete ... £7 10s.
- WE CARRY FULL STOCKS OF** all American Components, Receivers, and Transmitters.
- HAMMARLUND. PRO., & SUPER PRO—PEAK PRE-SELECTORS—**
- COLLINS AND TOBE GEAR—**
- RAYTHEON R. K. TUBES—RECEIVERS AND TRANSMITTERS** by EIMAC-AMPERIX-362 and HIVAC "MIDGETS."

Send stamp for our "T.S.W." List.

G.2.N.O 11, LICHFIELD ST., WOLVERHAMPTON.

"... of very definite usefulness to amateurs and to be recommended very highly."—T. & R. BULLETIN, Dec., 1935.

**PRACTICAL
RADIO
COMMUNICATION**

Principles—Systems—Equipment—Operation: including Short-wave and Ultra-short-wave Radio

By **ARTHUR R. NILSON**

Lieutenant (Technician)
(Communications), U.S.N.R. (Retired)

and **J. L. HORNUNG**

Formerly Radio Instructor, Guggenheim School of Aeronautics, New York University.

754 pages, 6 × 9, 435 illustrations, flexible. Price 30/- net

Features of this book :

- covers the entire spectrum of radio waves; ultra-short-, short-, medium-, and long-wave radio transmission and reception.
- gives special attention to alternating current engineering principles and their applications in radio transmission and reception.
- covers transmitting, receiving, and power generating apparatus for all types of stations.
- includes marine, aeronautical, police, and amateur radio, with especial attention to broadcasting, and studio and control-room equipment and operation.
- written in simple, concise style, with many illustrations and diagrams.

CHAPTER HEADINGS

- | | |
|--|---|
| 1. Direct-current Electricity and Magnetism. | 8. Control-room Equipment and Operation. |
| 2. Alternating-current Electricity. | 9. Broadcast Transmitters. |
| 3. Introduction to Vacuum Tubes. | 10. Communication Transmitters. |
| 4. Transmitting-circuit Principles. | 11. Radio Receivers. |
| 5. Receiving circuit Principles. | 12. Radio Aids to Navigation. |
| 6. Antennas and Wave Propagation. | 13. Rectifier Units. |
| 7. Studio Acoustics and Apparatus. | 14. Dynamo-electric Machinery and Meters. |
| | 15. Storage Batteries. |

McGraw-Hill Publishing Co. Ltd.
Aldwych House, London, W.C.2

Our Readers' Views

Correspondence is invited. The Editor does not necessarily agree with views expressed by readers which are published on this page.

Implosion

SIR,

With reference to the paragraph in last month's issue on the possibility of danger owing to cathode-ray tubes bursting your readers may be assured that there is little or no danger with the latest type of tube—that is, of course, excepting physical violence. A comparatively short time ago such an occurrence was not unusual, but improved methods of manufacture have almost entirely removed the possibility. Moreover, a "burst" is very unlikely to do any harm owing to the manner in which it usually takes place. Experience has shown that the tube is not shattered into small fragments as might be supposed so that there are not a multitude of flying particles of glass. As a rule the fracture occurs at the neck and when this happens it usually has the effect of forcing the large end out and this comes away in one piece like a glass plate and owing to its thickness there is little probability of this breaking into small pieces. Complete fracture of the body of the tube is very uncommon.

Any potential danger which might be supposed to exist can, of course, be absolutely nullified by the use of a screen of glass, particularly if this is the type used for car screens. and I know that some manufacturers who are busy designing receivers are incorporating this method of protection. Naturally there will be a slight loss of light, but this will probably be less than occurs when a reflecting mirror is used.

B.M. (London, W.C.).

Neutralising the P.A. Stage

SIR,

I notice that there are no comments in your March issue concerning the article "Neutralising the P.A. Stage" on page 72 of your February number, and with your permission I should like to add to this excellent article.

Mr. Crewe states that "Grid neutralising is always preferable when link coupling is used between stages, for it makes possible the use of cheaper variable condensers." I use link coupling in my transmitter with anode neutralising, and to overcome the danger of D.C. short-circuits across the neutralising condenser, I have connected an ordinary .0001 μF. mica dielectric fixed condenser in series with it, on the anode coil side. This in no way affects the neutralisation but removes the D.C. potential across the air-spaced plates.

Then Mr. Crewe mentions only one method of determining the point of exact neutralisation. I would point out that this method is not very accurate, since the method of indication,

CATALOGUES.



SHORTWAVE illustrated catalogue gives diagrams of efficient receiver and transmitter and base connections of American valves, 14d.

CLEARANCE catalogue is easily the most comprehensive published and lists thousands of bargains, 14d.; both sent for 3d. post free.

RAYMART Type CHP Chokes as specified for 112-29 mc Super-het, 9d. each.

Enquirers must send stamp for reply.

19, JOHN BRIGHT STREET, BIRMINGHAM.

CORRIGENDUM

RFP15 — 30/-

Filament Volts ..	4
Filament Amps. ..	1
Anode Volts ..	500
Max. Anode Input ..	25 watts
Max. Anode Dissipation ..	15 watts
Anode Load ..	10,000 ohms
Screen Volts ..	300
Speech Input ..	1 watt
Radio Input ..	6 volts (R.M.S.)

The above particulars correct some errors which appeared last month.

362 RADIO VALVE Co. Ltd.
STONEHAM WORKS, E.5

Classed 6607.

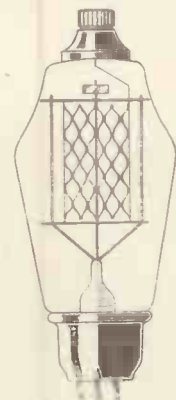

Read
"Television
and
Short-wave
World"
Regularly

APRIL, 1936

i.e., a loop lamp, etc., coupled to the P.A. tank coil, requires power to operate it, and the circuit may be quite a long way from neutralisation while there is insufficient power in the P.A. coil for indication purposes, but enough for considerable feed-back. The method I use is a loop lamp loosely coupled to the oscillator tank coil. This lamp gives a "flicker" as the P.A. tank circuit is tuned through resonance when the P.A. is even the slightest amount off neutralisation. The lamp draws no power from the P.A. circuit, so that its presence does not affect the point of neutralisation in the slightest, whereas a loop coupled to the P.A. tank coil will upset the balance of the circuit and seriously alter the neutralisation characteristics of the P.A..

Some amateurs watch for the flicker of the needle in the oscillator anode current meter, but I find that the use of a lamp as described above is far more sensitive.

The neutralisation of a link-coupled P.A. is considerably easier than that of a direct-coupled circuit.

D. GORDON BAGG (G6BD),
(Tonbridge).

Dow Electron-coupled Oscillator

SIR,

I notice that with the majority of the high-frequency amplifiers designed that regeneration is recommended to increase sensitivity. Why is it that the Dow electron-coupled oscillator is always employed?

It has been my experience that a cathode coil with a potentiometer across it and coupled to the grid coil gives even better results without having to make special coils.

This system also works quite well in the I.F. stages and gives almost crystal gate selectivity.

It would be interesting to have the views of your readers of electron coupling and the cathode coil method of obtaining generation.

J. T. PEARSE (Windsor).

The 40-metre Band

SIR,

In 1937 the Cairo Convention will determine whether or not amateur bands should be increased. As the present 40-metre band is almost useless for the serious experimenter it

Our Policy
"The Development of
Television."

will be a good idea if phone stations were prohibited from using this band. It would at least be a help if the French stations were restricted to 100 per cent. modulation.

I do not think that even if the band is widened that there will be sufficient room for all the over-modulated 40-metre phone stations on the air at the moment. An alternative is to resurrect the 30-metre amateur band and allocate it to those who wish to do some serious experimenting work. This could, of course, be kept for C.W. only. R. FINDON (Brighton).

Reliance Potentiometers

Reliance Manufacturing Co., Ltd., are producing an excellent range of noiseless wire-wound potentiometers with dead spindles costing only 4s. 6d.

The units can be obtained in any standard value from .5-megohm to 100,000 ohms. They are particularly suitable for L.F. and H.F. gain controls and at the same time will carry a steady current flow without breaking down.

Low-value resistances for television time bases are also available. These are particularly suitable for cathode-ray tube heater circuits.

B.T.S. ACKNOWLEDGED THE BEST

SPECIFIED for the
U.H.F. SUPERHET
AIR DIELECTRIC FIXED CONDENSERS



Employs air-dielectric. Minimum losses are attained by reduction of insulating material. Type UP.C., C0C05 mmfd. **3/3**

Ultra Short Wave H.F. CHOKES
Low-loss insulating material tube. Easily wired into circuit without increasing capacity.
No. 1, 10-100 metres, 1/6
No. 2, 3-30 metres 1/-



Ultra Short Wave VALVE HOLDERS
Low loss insulating material. Silver plated sockets. With terminals.
Type UH/4, 4-pin, 1/-; UH/5, 5-pin, 1/3; UH/7, 7-pin, 2/-; UH/9, 9-pin, 2/3.

Your Dealer Stocks them

Send 3d. in stamps for No. 1 of B.T.S. magazine, "Short Wave Constructor."

B.T.S.

BRITISH TELEVISION SUPPLIES LTD.
Faraday House, 8-10, Charing Cross Rd., London, W.C.2
Phone: Grams: W.C.2
Tem. Bar 0134-5. Television, Lesquare, London.

SHORT WAVE COMPONENTS

"RELIANCE" for "RELIABILITY"
For Quality and Precision apparatus designers invariably choose "Reliance"
VOLUME CONTROLS and POTENTIOMETERS



Here are a few interesting specifications:
"Television & S. W. World," Sept., 1935.
"SHORT-WAVE RECEIVER," One 25,000 ohm ... 4/6
Nov., 1935.
"ADVANCE ALL-WAVER" One 500,000 ohm ... 4/9
"TWO H.F. PRE-AMPLIFIER" One 50,000 ohm ... 4/6
March, 1936.
"BATTERY S. W. SUPER-HET" One 500,000 ohm ... 4/9
April, 1936.
"BATTERY FREQUENCY METER" One 100,000 ohm ... 4/6
"Wireless World," 1936
MONODIAL SUPER. One Tapered Volume Control, Type GLT. 1 megohm ... 4/9
RESISTANCE AND CAPACITY BRIDGE One Type TW.20,000 ohms 4/6
...
SURE PROOF OF THEIR RELIABILITY
WIRE-WOUND: 500 ohms to 100,000 ohms ... 4/6 each
COMPOSITION: 50,000 ohms to 5meg. 4/9 each
Folder T.5. Free.

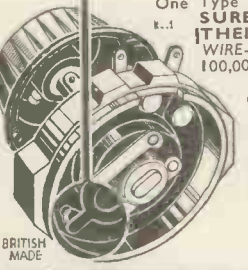

RELIANCE
THE PRODUCT OF SPECIALISED RESEARCH

BRITISH MADE

RELIANCE MANUFACTURING CO. (SOUTHWARD) LTD.
WESTBURY ROAD, LONDON E. 17.

Inexpensive long-life METERS...



for all your radio tests!

SIFAM Meters specified for Short Wave Receivers.

Magnetic type E66M	Milliammeters 0-10 m.a. to 0-500 m.a.	10/-
Moving Coil type M70	Milliammeters 0-2 m.a. to 0-100 m.a.	27/6
	0-200 m.a. to 0-500 m.a.	30/-
FM Signal Level Indicator, reads "R" signals direct on dial		£2-2-0

SIFAM METERS

Post this Coupon to-day.

Please send your fully illustrated list No.
Name.....
Address.....
(Use Block Letters)
SIFAM ELECTRICAL INSTRUMENT Co., Ltd.,
Hollydale Road, London, S.E.15.
Phone: New Cross 2168.
A SIFAM TEST'S A SAFE TEST

"The Broadcasting Committee's Report"

(Continued from page 249).

annual expenditure will become common to both types of service.

We think it well to point out that what has been entrusted by His Majesty's Government to the B.B.C. is the conduct of a "public broadcast service of television," and that other applications of this new art, such as the transmission for commercial purposes of visual images from point to point, remain entirely within the sole competence and control of the Postmaster-General.

Calls Heard

W9DXX, Alice R. Bourke, Chicago, U.S.A.

(14 Mc. C.W.)

CM2AD, 2AX, 2BG, G5WG, HC2MO, HI5X, HR2UK, K5AC, 5AL, IT2AV, VE2CB, 2DV, 3JET, 3UW, 4DP, 4EM, 4LK, 4MB, 4OC, 4VD, 5AL, VP1JO, 1JR, XE1DA, 2N, YN1OP, ZS2A.

(28 Mc. C.W.)

CM2AF, D4CSA, EA4AO, FA8BG, G6DH, 6NF, 6RH, K4AUP, K5AL, LU9AX, OA4B, ON4AU, O4LX, VE1DZ, V1BF, 4GW, 4LQ, 4LZ, 4ZQ, 4UY, 5IS, 5KC, 5QA, VP5PZ, XE1CM, 1AY, ZS1H, 2A, ZU1C.

2BAI, K. Howell, Acton, London.

(7 Mc. Phone.)

G6DL, 6AG, 6QZ, 6ZR, 6IF, 6MD, 6CJ, 6OX, 5YY, 5ZJ, 5RF, 5RX, 2FN, 2GR, 2UQ, 2KX, 2IC, 2QY, 2FM, 2XJ, PAOWJ, PAOEO, PAOFB, PAOZM, PAOZB, PAOHB, PAOFY, ON4US, O4GU, D4LIM, F8RR, 8WQ, 3AM, 3DM, 8LU, 8NV, 8KJ, SM5UM, SM6AN, CT1IJ, YM4AF, SP1AU, 1FB, 1HN, 1IA, 1LM, OK1BC, OZ8R, 8X, EA2BC, EA3DZ, 3EG, EA5BO, EA7AK, 7AV.

(14 Mc. Phone.)

W1AJZ, 1CRW, 1CND, 1DKL, 1BFI, 1BSN, W2AIG, 2EVI, 2BSD, 2ADW, 2AYG, 2CTX, 2FCD, 2BOQ, 2HFS, 4TW, HAF5C, HI5X, K4SA, YM4AA, LA4N, LA4K, ZU6P, YI6GF.

B.R.S. 1,784, Martin F. Bourke, Samares, C.I.

(1.7 Mc. Phone.)

G6GO, 6PC, 6KV, 5OC, 5PB, 2XC, 2II.

(1.7 Mc. C.W.)

VE1EA, FM8D.

(3.5 Mc. Phone.)

W3EFS, 3CWG, 8DBV, 4ALD, 1IQY, 3EOZ, 8BWH, VE1EI.

(7 Mc. C.W.)

ZB1H, U4OG, CN8MF, YR1DB, VK3ZW, VE1IU, 1ET, 1EP.

(14 Mc. Phone.)

VP9R, HI5X, VE3EO, 3DD, VP3BG, VO1I, CO2OL, VK4KU, VK3GN, 2YW, 2BQ, G6UU.

(14 Mc. C.W.)

VK2KM, 2PX, 3JT, 3XP, 3CZ, 3CX, 5MD, 3PC, 3MR, 3AM, 5RT, 2RZ, 2KS, 2OC, 2ER, 2TF, 2VE, 3DJ, ZL2ZA, 3JA, 3GN, 3AB, 4BO, 2OQ, 3GN, ZS1AH, ZB1H, ZB1E, VQ4CRO, ZE1JE, SU1WM, 1SG, 5NK, U2NE, 1BL, 1CN, VO1C, OE7EJ, FA8CR, FN8SR, VT7MT, VE3SV, FM8D, K5AC, FA8SR, LU2AM.

(28 Mc. Phone.)

W1AAK, 9BHT, 3AIR, 3BSY, 3BVE, K4DDH, OA4B.

(28 Mc. C.W.)

W1, 2, 3, 4, 5, 8, 9, CN8MQ, SU1JT, 1SG, QH5NG, 7ND, 7NF, CP1AC, VP5PZ, VE3UF, 3ER, ZS1H, G6RH, U1BC, 9AV, 3AG, LU9AX.

B.R.S. 1,847, J. R. Jagger, Guildford, Surrey.

(28 Mc. Phone.)

W1ZD, DQD, AF, HUV, AAK, BQQ, ARC, HRX, EWF, HHU, IXI, DZL, W2UK, INX, GJB, EUG, AOG, EJC, HIJ, FWK, AWC, DC, W3WA, AKX, AUC, DRA, AIR, PC, CRG, EET, W5BEE, BGT, DUQ, BXA, EHR, BV, AMZ, AHJ, EYZ, BDB, W6KSE, DZH, GRL, NKG, BCD, MDN, W8AGU, MYJ, DJM, FXM, MWL, FUQ, NOL, EBS, W9AGO, BHT, CJJ, DHK, BVK, ARN, LLX, UUN, K4DDH, K6NBG, NJV, G5BY, 5JW, 6GO, 6LK, 6DH, VE3AEL, VE4NC, OA4B.

FIELD DAYS AHEAD!

One of the greatest attractions of Amateur Radio is Field work. During the coming summer the Radio Society of Great Britain will organise National and local field day events.

NATIONAL FIELD DAY takes place during the second week-end in June. Stations in all Districts will be operating portable apparatus—if you are interested in this fascinating side of Amateur Radio, you will be welcomed at the station nearest your home.

5 METRE FIELD DAYS are planned including an International Field Event in July when DX working is anticipated.

THE R.S.G.B. caters for the Social side as strongly as the Technical side of Amateur Radio.

Details of the Society's work can be obtained on application to:—

The Secretary,

RADIO SOCIETY OF GREAT BRITAIN

(Dept. S.W.9)

53 Victoria Street,

London, S.W.1.

THE TELEVISION SOCIETY

President: Sir AMBROSE FLEMING, M.A., D.Sc., F.R.S.

Founded in 1927 for the furtherance of Study and Research in Television and allied Photo-electric Problems.

Ordinary Fellows are elected on a Certificate of Recommendation signed by Two Ordinary Fellows, the Proposer certifying his personal knowledge of the Candidate. The Admission Fee for Fellows is half-a-guinea, payable at the time of election, the Annual Subscription is £1, payable on election, and subsequently in advance on January 1st in each year, but the Annual Subscription may be compounded at any time by the payment of Ten Guineas.

Any person over 21, interested in Television, may be eligible for the Associate Membership without technical qualifications, but must give some evidence of interest in the subject as shall satisfy the Committee. For Associate Members the Entrance Fee is 5/-, payable at the time of election, with Annual Subscription 15/-, payable in advance on January 1st in each year.

Student Members.—The Council has arranged for the entrance of persons under the age of 21 as Student Members, with Entrance Fee 2/6 and Annual Subscription 10/-, payable as above.

The Ordinary Meetings are held in London on the second Wednesday of the month (October to May inclusive) at 7 p.m. The business of the meetings includes the reading and discussion of papers. A Summer Meeting is usually held, and affords Members the opportunity of inspecting laboratories, works, etc. A Research Committee and the preparation of An Index of Current Literature are active branches of the Society's work.

The Journal of the Television Society

is published three times a year. All members are entitled to a copy; and it is also sold to Non-Members, at an annual subscription of 15/- post free.

Forms of proposal for Membership, and further information regarding the Society, may be obtained on application to the Business Secretary, J. J. Denton, 25, Lisburne Road, Hampstead, London, N.W.3.

APRIL, 1936

"ALL THE WORLD'S A STAGE"



WITH A
**SHORT-WAVE
CONVERTER**
Mervyn 13/55m .. 42/-
7 metre model .. 70/-
B.T.C. Beginners .. 30/-
TELEVISION

Time Base Kit .. 130/-
3,500v. H.T. Unit .. 66

Shortwave Condensers Ceramic Endplates .. 4/6
All brass, with slow motion .. 4/6 Shortwave
Chokes .. 1/6 S.W. Ceramic 4 & 5 pin chassis
type valveholders .. 1/- each. **LISTS FREE**
BENNETT TELEVISION CO.,
5 STATION ROAD, REDHILL.

**NEW LINES AT
BARGAIN PRICES**

UNIVERSAL AMPLIFIERS.

6-8 Watts undistorted output
£6 10 0. Carr. Paid. Cash with order
or C.O.D.

A.C. Double Push-Pull R.C.C. Coupled.
AMPLIFIER.

Undistorted output 5-Watts.
£7 5 0. Carr. Paid. Cash with order
or C.O.D.

We can supply **KIT** of parts for the
"U.H.F. 112-28 Mc SUPER-HET" at
very competitive prices.

We can supply an equivalent for any British
type of Valve at an appreciably lower price.
These valves are Guaranteed for a period of
6 months from date of purchase and the
performance to be in no way inferior to that
of the original valve.

Send for comprehensive List "T.S."

CHAS. F. WARD,

46, Farringdon Street, London, E.C.4.
Telephone : Holborn 9703.

"Calls Heard" (contd. from p. 156.)

(28 Mc. C.W.)

57 W1, 41 W2, 32 W3, 6 W4, 41 W8,
29 W9 and W5AFX, EOG, QL, BDB,
SF, VV, EHM, ATY, W6, CQT, GRX,
BAY, JJU, AM, BAM, W7ESN, AMX,
FLU, BJP, AYQ, VE1DQ, VE2AC,
DC, CA, KA, JQ, V13ER, KF, AHK,
MQ, AQ, WAUF, QD, JK, VE4OC,
QZ, LZ, VE5EO, LU3DH, LU9AX,
9BV, CX1CC, OA4B, OA4J, CP1AC,
VP5PZ, ZS1H, ZU1C, ZS2A, XE1AA,
VS6AH, VE2AU, VU3BV, J3FK,
VK4AP, VK4GK, VK6SA, U3VC, 3AG,
U9PX, CT1BY, LA3M, OH3NP, K4,
DDH.

(3.5 Mc. C.W.)

W7BOU, BXN, W5AGD, W9ARR,
W9UL, W9KL, TVT.

Empire Calls.

(7 and 14 Mc.)

South Africa.—ZS1AH, 1D, 1M, 4J,
4M, 4U, 5Z, 6AQ, ZT6AC, 5V, 6E, 6M,
6Z, ZU1C, 5P, 5X, 6D, 6E, 6M, 6B,
5B, 5D, 5AP, 6A, 2X, 6AF, ZU1T, 6P,
ZT6S. Kenya.—VQ4CRO, CRH,
SNB. Newfoundland.—VO1C, 1H, 1X,
4Y. Mauritius.—VQ8AC, 8AB, 8AF.
Ceylon.—VS7JW.

High-Definition 7-Metre Converter
suitable for Sound. Price, less valve 70/-
TELEVISION UP TO DATE

All Leading experimenters are reading
this latest Handbook on High Definition.
124 Illustrations. Price 2/6, post 4d.
H. E. SANDERS & CO., 4, Grays Inn Rd.,
London, W.C.1. 'Phone: Chancery 8778.

**THE CONSTRUCTORS'
CIRCLE**

Application for Membership

To be filled in and sent with a
stamped envelope for reply to the
Editor, "Television and Short-wave
World," Chansitor House, Chancery
Lane, London, W.C.2.

- (1) I already subscribe to your
journal at the address below.
- (2) I have placed a regular order
for TELEVISION and SHORT
WAVE WORLD with my book-
sellers, Messrs.....

.....
.....
and desire to be enrolled as a
member of the TELEVISION
and SHORT WAVE WORLD.
"Constructors' Circle."

Please send membership badge
free of charge to

Name (in block letters)

Address

*Strike out lines not applicable.

Additional Members.

R. H. D. Porter, "Stilrovin," Cornwall
Road, Littlehampton; A. Beaden, 15 Gar-
baldi Street, Warrington, Lancs.; J. H.
Jenkins, 67 Paulsgrove Road, North End,
Portsmouth, Hants.; S. May, 18 Church
Gate, Leicester.

**"TELEVISION COUPON
and SHORT-WAVE WORLD."
FOR FREE INQUIRY SERVICE**

Name

Address

April, 1936

FOYLES

BOOKSELLERS TO THE WORLD
Stock of nearly three million new and second-
hand volumes. Catalogues free on mentioning
interests.

119-152 Charing Cross Rd., London, W.C.2.
Telephone: Gerrard 5660(12 lines)

**MISCELLANEOUS
ADVERTISEMENTS**

The charge for advertisements in these
columns is 12 words or less 2/-, and 2d. for
every additional word. All advertisements
must be accompanied by remittance. Cheques
and Postal Orders should be made payable to
Bernard Jones Publications Ltd., and crossed,
and should reach this office not later than the
15th of the month previous to date of issue.

FOR SALE.—T6xD valve unused, £4. Box No. 5.

MARCH (SPRING) CALLBOOKS. Latest edition
now on sale, price 6/-, post free. Hundreds of new DX
calls. The Callbook is a necessity for every short wave
transmitter or receiver. G5KA, 41, Kinfauns Road,
Goodmayes, Essex.

**PATENT AND TRADE
MARK AGENTS**

GEE & CO. (Estab. 1905), patents and trade marks
throughout the world (H. T. P. Gee, Mem.R.S.G.B.,
A.M.I.R.E., etc.), 51-52, Chancery Lane, London,
W.C.2 (2 doors from Government Patent Office.)
'Phone: Holborn 1525. Handbook free.

PATENTS. Trade Marks Advice. Handbook and
Consultations free.—B. T. King, Patent Agents, G.B.,
U.S.A. and Canada, 146a, Queen Victoria Street,
London, 50 years' references. City 6161.

PATENTS AND DESIGNS ACTS, 1907 to 1932,
NOTICE is hereby given that Marconi's Wireless
Telegraph Company, Limited, of Marconi Offices,
Electra House, Victoria Embankment, London, W.C.2,
seek leave to amend the specification (including the
Drawings) of Letters Patent No. 434,496 granted to
them for an invention entitled "Improvements in or
relating to television and like receiving systems."
Particulars of the proposed amendment were set forth
in No. 2,458 of the Official Journal (Patents), published
on February 26th, 1936.

Any person, or persons, may give Notice of Opposition
to the amendment by leaving Patents Form No. 19 at
the Patent Office, 25, Southampton Buildings, London,
W.C.2, within one calendar month from the date of
publication of the said journal.

M. F. LINDLEY,
Comptroller-General.

INDEX TO ADVERTISERS

Belling & Lee, Ltd.	Cover ii
Bennett Television Co., Ltd.	Cover iii
British Television Supplies, Ltd.	255
Bulgin, A. F., & Co., Ltd.	193
Edison Swan Electric Co., Ltd.	Cover iv
Ferranti, Ltd.	193
Fluxite, Ltd.	Cover ii
General Electric Co., Ltd.	Cover ii
G.2.N.O.	253
High Vacuum Valve Co., Ltd.	249
Lectro Linx, Ltd.	249
Mervyn Sound & Vision Co.	252
McGraw-Hill Publishing Co., Ltd.	254
Quartz Crystal Co.	252
Radio Resistor Co., Ltd.	251
Radio Society of Gt. Britain	256
Raymart Manufacturing Co.	254
Reliance Manufacturing Co.	255
Sanders, H. E., & Co.	Cover iii
Savage, Bryan	251
Scientific Supply Stores (Wireless), Ltd.	253
Sifan Electrical Instrument Co., Ltd.	255
Sound Sales, Ltd.	193
Streamline Radio, Ltd.	247
Stratton & Co., Ltd.	247
Television Society	256
The British Institute of Engineering Technology	252
The Photographic Electrical Co., Ltd.	194
Ward, Chas. F.	Cover iii
Westinghouse Brake & Signal Co., Ltd.	253
W. T. Henley's Telegraph Works Co., Ltd.	194
362 Radio Valve Co.	254
362 Radio Valve Co.	194

TELEVISION DEVELOPMENTS

A NEW LARGE DIAMETER TUBE FOR TELEVISION REPRODUCTION



The Ediswan Type CH tube has a screen diameter of 10" giving a television picture 8" x 6" without distortion.

The screen is of special material giving a close approximation to a black-and-white picture.

Specification:

Indirectly heated high vacuum tube.

Heater Volts - - - 2.0

Anode Volts - - - 3500

1st Anode Volts - - - 1200

Sensitivity (mm./V.) - - - 750/V*

*V = anode volts

List Price £12.0.0

• We also supply
HIGH VACUUM RECTIFIERS
GAS-FILLED RELAYS
MERCURY VAPOUR RELAYS
for Television Scanning
circuits.

ENTIRELY BRITISH MADE

EDISWAN RADIO VALVES

THE EDISON SWAN ELECTRIC CO. LTD.  155 CHARING CROSS RD., LONDON, W.C.2

R.E.280

USED BY ALL GOVERNMENT DEPARTMENTS