

Electronics

AND
TELEVISION
AND
SHORT-WAVE WORLD

EDITORIAL, ADVERTISING AND PUBLISHING OFFICES
CHANSITOR HOUSE, 37/38, CHANCERY LANE, W.C.1

Editor-in-Chief : BERNARD E. JONES
Editor : H. CORBISHLEY, F.T.S.

Telephone : HOLBORN 6158, 6159 & 2857
Telegrams : BeeJaPee, Holb., London

Subscription Rates ; Post Paid to any part of the world—3 months, 5/- ; 6 months 10/- ; 12 months, 20/-. Published monthly, 1/6 net, first day of the month. Proprietors : BERNARD JONES PUBLICATIONS LIMITED.

News and Views

Television—A Disappointment

SIR NOEL ASHBRIDGE'S statement at a Press conference early last month will come as a disappointment to many who had a lingering hope that the television service would be resumed after the B.B.C. had had time to take stock of the position.

He stated that there would be no possibility of renewing the service during the period of the war, so far as could be seen, and advanced three reasons for this decision:—

In the interests of national security it is undesirable to radiate the television signal.

The demands of the sound broadcasting require a large number of engineers to maintain a 24-hour service.

The television service is relatively expensive in view of the limited audience at present.

That these are sound reasons, no one would deny; in fact, the first alone would be sufficient justification for the suspension of the service. The range of the station has, we know, proved greater than was expected, and it is not to be supposed that the enemy would be solely concerned with the entertainment value of the transmission!

The second reason answers in part a question which has been asked by numerous friends of the Alexandra Palace staff: "Where are they?" Even now we do not know officially what has become of the producers and studio staff who have provided our entertainment. No doubt they

will turn up smiling at the end of the war, and we shall see the majority of them again.

It is, however, most unfortunate that the television service is prevented from operating at the very time when its value would be greatest. We hear continually of the risk attached to assembly in large crowds—in the home there would be entertainment in comparative safety, and the provision of an hour's programme of films or variety late at night would do much to mitigate the discomforts of the black-out.

Receiver manufacturers are not suspending all television development for the duration—to do so would be to lose all the start that we have obtained over our American friends. The temporary loss in business seems likely to be offset by the increased demand for short-wave and communication receivers, of which the sale is increasing daily, particularly in the case of the latter.

A.R.P.A.—One side of the entertainment field seems to have been neglected and this is the provision of news and music for the inhabitants of air-raid shelters.

There are, of course, two sides to the question. Some may say that it is bad enough to be confined in an underground cellar for some hours without the added discomfort of listening to swing music badly reproduced. In this, a great deal must be left to the good taste of the responsible official, but a P.A. equipment properly installed would add to the

comfort of the staff and it might be used for relaying information on the progress of a raid or for making announcements at critical times. No doubt radio dealers will be ready to take advantage of the opportunity afforded them in this direction.

Television Range-finders.—A recent television development in America by Dr. Alfred N. Goldsmith is a television range-finder. The operating principle of the device is that the size of the image depends on the distance of the receiver from the transmitter; and the screen of the receiver is, therefore, calibrated to give a reading of distance. This new television range indicating system it is announced has a number of applications both in peace and war.

With the ordinary television receiver, of course, the size of the image has nothing to do with the distance of the receiver from the transmitter, but in this new development a special circuit is employed in the receiver whereby the size of the spot on the screen of the cathode-ray tube is varied according to the strength of the incoming signal and at a distance of, say, a mile from the transmitter, the image will be a certain size on the screen of the tube, or at a distance of half a mile, the image will be proportionately larger. Suitable calibration scales on the end of the tube enable the operator to quickly determine the approximate distance of the transmitter. A constant strength of radiation from the latter is, of course, essential. The size of the spot on the cathode-ray screen is varied by utilising an additional focusing coil around the tube.

TRANSPARENCY, COLOUR AND GLOSS COMPARISONS WITH THE PHOTO CELL

THE majority of inspection and checking operations in industry involve the comparison of quality against a pre-determined standard. In this, as in nearly all processes in which the human element is present, the eye cannot be relied on to give the same unbiased judgment day after day. Such factors as fatigue, local surroundings and even general health all affect the observer's capacity and tend to produce variations in the tolerances which are consciously or unconsciously allowed.

If, however, the comparison process is reduced to a single observation on a meter, the risk of variation

If the eye is replaced by a photo-cell, the problem is solved. The cell can only record what is presented to it in the form of light intensity and reproduce it in the form of current.

If the operating conditions do not vary it will give the same reading day in, day out, without fatigue and without bias.

Accordingly all inspection and comparison operations are as far as possible submitted to the photo-cell for judgment and its readings are taken as the final pronouncement on the similarity of sample and standard for all kinds of manufactured products.

Three examples of its use in comparing quality are found in the colour comparator, the "glossmeter" and the thickness measurer for translucent materials.

In the first case it is desired, say, to compare the colour of two liquids to determine whether there is any turbidity or to check the concentration of a dye. To do this two flat-sided glass cells are filled, one with the liquid under test and the other with the standard sample. A lamp is placed mid-way between the two and the light passing through the cells is received on two photo-electric elements which are differentially connected so that their outputs are opposed. A microammeter completes the circuit. If the two liquids are identical, the amount of light passing through them on to the photo-cells is the same and the output is equal and balanced. There is thus no reading on the microammeter. If one liquid is thicker than the standard specimen, the light is correspondingly absorbed and the microammeter gives a reading proportional to the absorption.

The diagram of Fig. 1 shows the arrangement of suitable apparatus produced by Salford Electrical Instruments, Ltd. A and B are the

cells containing the liquids and C and D the photo-cells. Two light filters E and F may be inserted if necessary.

The resistances G and H serve to calibrate the microammeter or to reduce its deflection if required.

A similar arrangement could be used for comparing the light reflected from two coloured surfaces, although the results might be difficult to reconcile if the texture of the two surfaces were different.

Gloss Meter

The gloss meter, also made by Salford Electrical Instruments, Ltd., requires a single photo-cell which receives light reflected from a surface, such as a sheet of glossy paper.

The output current obtained from the standard specimen is compared with that obtained when the sample under test is substituted.

The apparatus is shown in outline in Fig. 2. A small lamp is mounted

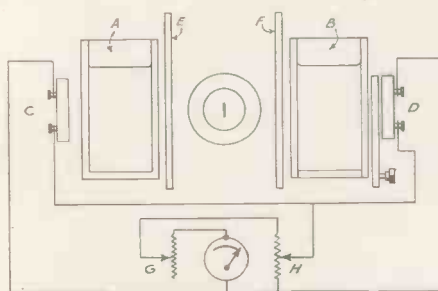
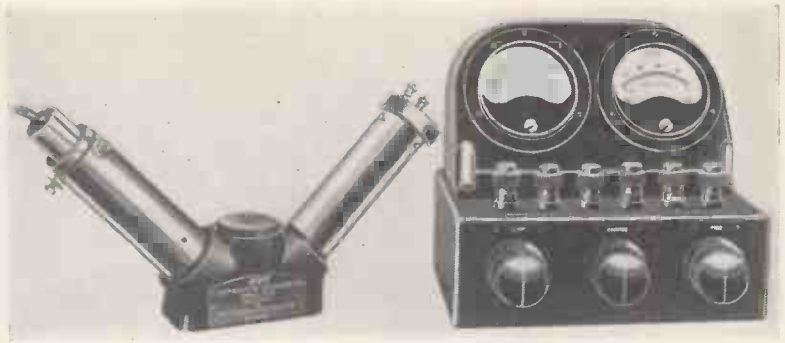

Fig. 1.—Schematic diagram of Salford photo-electric colorimeter.

due to the individual is reduced to a minimum. No trained engineer can mistake a meter indication and it only becomes a matter of practice before an unskilled worker can be relied on to note a reading with almost the same degree of accuracy.

In comparing such quantities as colour, thickness or surface quality, the difficulties of establishing a standard are greatly increased. No two persons are likely to have the same appreciation of shade of colour unless they have an aptitude for the work, and even then there is no guarantee that their ideas coincide. It is the old problem of asking the colour-blind man what colour he sees!



The Salford Comparative Gloss Meter.

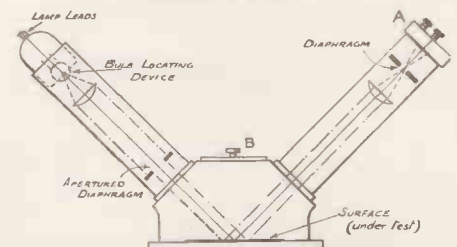

Fig. 2.—Diagram of comparative gloss meter.

so as to throw a beam of light at 45° on to the surface under observation. The reflected light is received by a photo-cell at A. If it is required to measure the diffused light reflected from the whole surface, the cell is fitted on top of the specimen at B.

Transparency Measurements

A similar arrangement is used for the comparison of transparency, the

(Continued at foot of page 629)

HIGH - FREQUENCY HEATING

SOME NOTES ON THE DESIGN OF AN H.F. CURRENT GENERATOR FOR LABORATORY PURPOSES

By *J. A. Sargrove. N.C.M.E. F.T.S M.Inst.B.E.*

(Chief of the Technical Dept. British Tungsram Radio Works Ltd.)

Whilst High Frequency Heating has been employed in the radio valve industry for many years, its wider application to metallurgy, in particular to light-alloy research, is not general. In this field and many others in which it is necessary to heat specimens rapidly and control their temperature accurately, at the same time excluding air so as to avoid ignition or oxidation, no better method is available.

The lightest metals such as lithium, beryllium, magnesium and their alloys, such as the so-called electron-metal, etc., which are going to gain increasing importance in the Aircraft Industry are highly inflammable in their pure state hence the use of the ordinary crucible furnace with these is impracticable.

Some points in the design of an H.F. Eddy-current Generator for laboratory work are discussed in this article.

IT is a well-known fact that when it is desired to heat up metal electrodes to a bright-red or white heat in a glass envelope without melting the glass, as in the case of thermionic valve manufacture, the only satisfactory way of doing this is to use H.F. eddy-current heating apparatus.

The problem consists of transferring oscillatory energy from the H.F. generator into the metal electrode and allowing this energy to dissipate in it; the temperature of the electrode rising in the process (particularly if it

As we cannot use iron cores but must content ourselves with air cores (or in most cases with vacuum cores) the optimum coupling will obviously occur if we choose a high frequency corresponding as near as possible to the natural or resonant frequency of the object or electrode it is intended to heat.

Effect of Wavelength

It has been found that different wavelengths give better heating effect on different sized objects and thus the problem of eddy-current

Spark-gap Generators

In valve factories spark-gap type of gear is mainly used due to the fact that these can be easily designed for a particular limited range of power and frequency and are cheap to maintain; their efficiency, however, is comparatively low.

Various sizes of generators are usually available so that different sized electrode assemblies requiring different power can all be heated with the least loss of power.

The diagram of Fig. 1 shows the

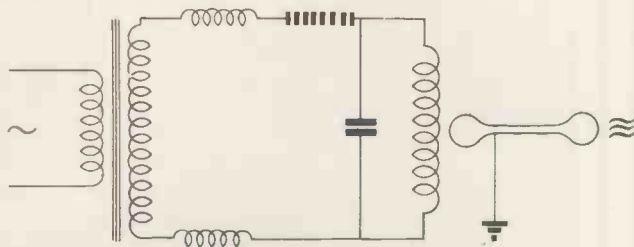

Fig. 1.—Circuit of spark-gap type of eddy-current furnace.

is in an evacuated space where it can only cool by radiation and conduction cooling is practically absent).

As the efficiency of H.F. eddy-current apparatus (usually abbreviated to E.C.H. apparatus) depends mainly on the quantity and the rate of transference of the energy into the object, one of the main problems is to secure efficient coupling.

heating is not only to provide H.F. energy, but also to make it available at the requisite frequency to suit the particular job.

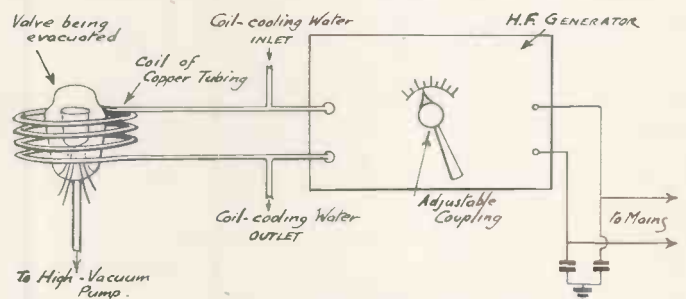

Fig. 1a.—Diagrammatic arrangement of E.C.H. gear in radio-valve manufacture. The cooling water earths the loosely coupled induction coil thus making it safe, from the "Factory Safety Acts" point of view. For metallurgical work instead of the valve inside the coil is placed the crucible of insulating refractory material (enclosed in a pirox glass or quartz receptacle which is connected to the pump).

simplicity of the circuit of these spark gap generators, and Fig. 1a the method by which the H.F. energy is applied.

In vacuum research and metallurgical laboratories, where it is not known in advance what the exact range of electrode sizes will be, valve-operated eddy current heating gear is of greater advantage. With these one can instantaneously govern the output power at will and can change the

unit using ordinary receiving type valves with a low voltage H.T. supply driving a larger output valve in class C amplifier conditions. This arrangement achieves the highest efficiency yet obtained and lies between 60-70 per cent.

In order to illustrate the method

of designing such apparatus, a particular example will be described.

Design of a 2 kW Output Class C Driven Eddy-current Heating Machine

Knowing the output required we can select a suitable output valve for

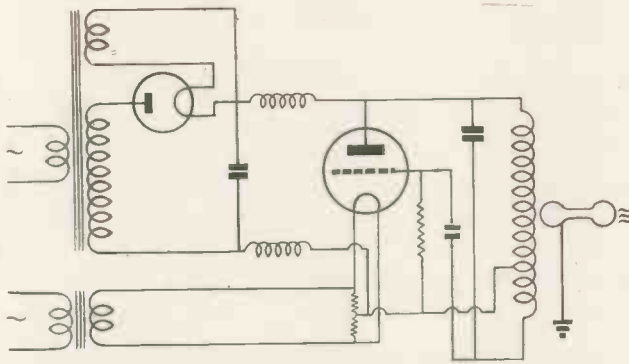

Fig. 2.—Hartley oscillatory circuit for valve operated E.C.H.

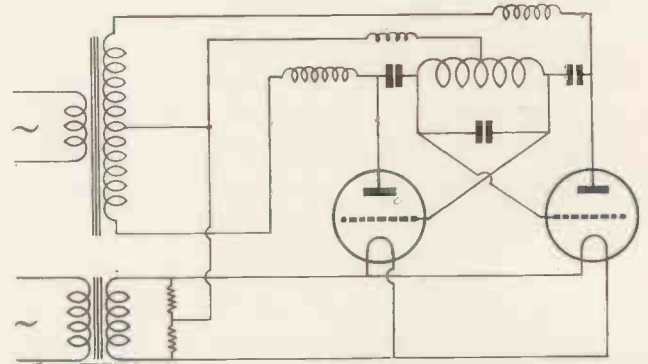

Fig. 3.—Push-pull class-C circuit for E.C.H. giving better efficiency.

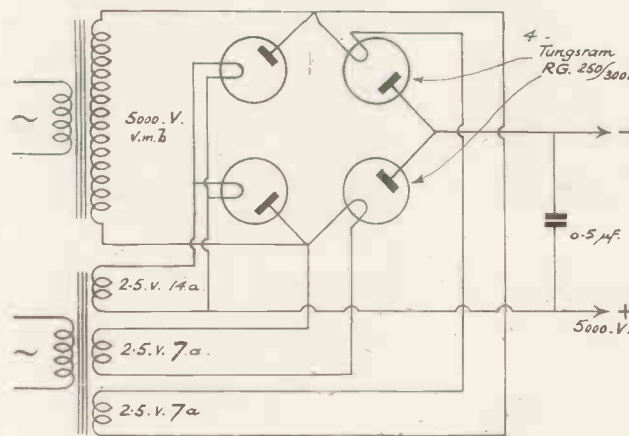

Fig. 4.—(left) Diagram of bridge rectifier circuit for power supply.

the purpose such as the Tungram O-1,500/5,000 whose rated characteristics are:

1,500 watts max. anode dissipation at 5,000 volts.

Anode current: 600 mA. r.m.s.

Normal grid current: 80 mA. r.m.s.

Continuous output of 2,000 watts at 1,000 watts dissipation.

If we wish to obtain the highest efficiency we must have a well regulated H.T. supply. In order to avoid using an expensive rectifier capable of standing up to the high inverse peak voltage of 15,000 volts, we can use the bridge circuit system

Fig. 5.—(below) Arrangement of a 2KVA E.C.H. machine suitable for laboratory work using Tungram type 0-1,500/5,000 as class-C amplifier.

output frequency throughout a wider range than with the spark gap type.

Valve-driven Generators

Valve operated E.C.H. gear can be based on various types of circuit principles. The simplest is the class B self-oscillatory type with a Hartley circuit (Fig. 2) having an efficiency of between 35-45 per cent. Better efficiency is obtainable from two smaller output valves in the symmetrical push-pull self-oscillatory class C type of circuit, as shown in Fig. 3. These can both be used with or without rectification. The efficiency of this arrangement is 40-55 per cent. In both these cases the valves are self-driven and hence the output is less than it could be and is dependent on the output circuit.

A much more economical arrangement, though somewhat more complicated, is to provide a small driver

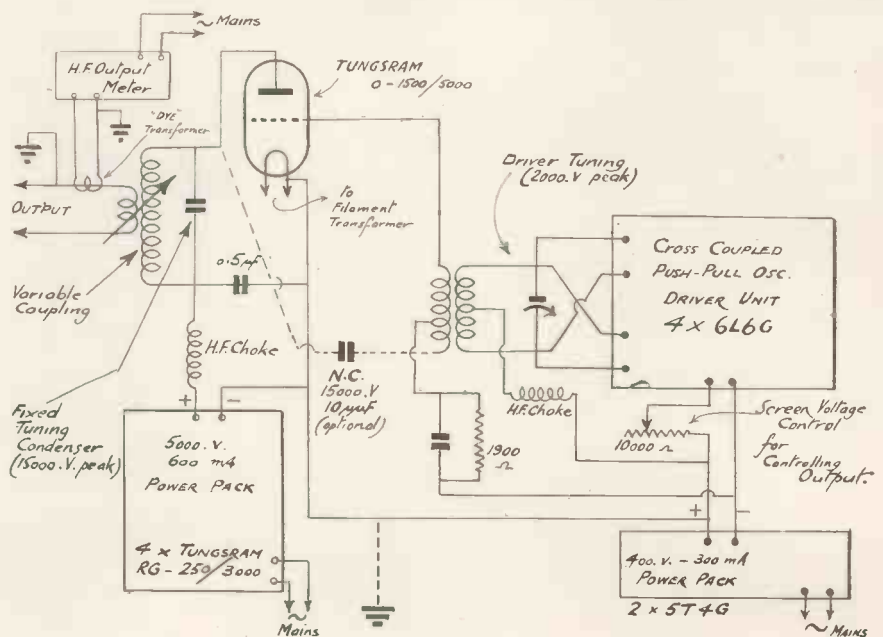

with four small and inexpensive mercury rectifiers, type RG-250/3,000. This circuit also obviates centre tapping the secondary of the 3 kVA transformer which thus only has to be made for 5,000 volts working terminal voltage.

This combination will be capable of a continuous output of 2 kW. itself, dissipating only 1 kW. in the

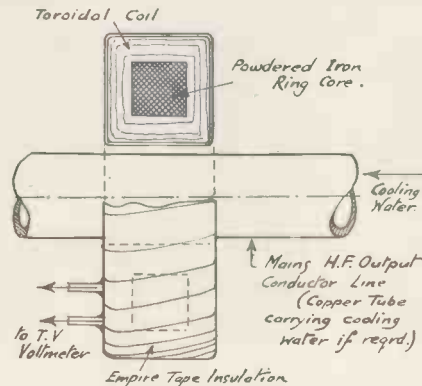

Fig. 6.—"Dye" current transformer for H.F. output meter in semi-cross section. (This is preferably coupled to a Thermionic valve voltmeter of the diode type for large currents using 6H6G or the Tungram D418.)

valve. The input energy is thus 3 kW. and allowing occasional intermittent overloads up to 4 kW.

The peak anode current that has to be provided during about 1/10th of a cycle is 1,200 mA. This may be extracted from the 0.5 μF. condenser shown across the bridge rectifier system in Fig. 4.

The output valve will require 400 volts bias for the class C operation and this may be provided from a separate bias supply or from the self-rectified grid circuit oscillation.

The best and safest course is to adopt both systems and a convenient compromise is to apply the 250 volt screen supply of the driver unit as constant negative bias and superimpose upon it 150 volts derived from the self-rectified grid current of the

output valve itself. The grid leak will thus have to be about 1,900 ohms as the r.m.s. grid current is 80 mA.

The grid condenser will have to be so designed that it will be large enough to maintain the grid bias throughout the cycle although grid current only flows during about 1/4th of a cycle.

After deducing the requisite transformer specifications we can give our attention to the driver stage. We can calculate the amount of energy required to drive the grid of the output stage positive during that part of the cycle when it takes current. This amounts to about 40 watts. As we have to provide for coupling losses and radiation loss it is advisable to make the driver capable of providing at least twice as much energy, the tuned inter-stage coupling acting as a "flywheel" from which the output valve grid circuit can take out all the energy during the phase when it draws grid current.

The valves in the driver stage are of the receiver type for low initial cost and economy in H.T. supply, and the best combination to choose for the driver is four parallel push-pull 6L6G valves. These will provide well over 100 watts, being ample to drive the 0-1,500/5,000 even on slight overloads above 2 kW. output.

A convenient and inexpensive power supply uses two Tungram 5T4G valves in full wave rectification.

This arrangement is shown completely in Fig. 5. It is obvious that the criterion for correct operation will be resonant tuning of the driver to the output circuit, the fixed tuning of which is affected by the size of the object to be heated. This tuning has to be adjusted for varying electrodes or specimens because as they are inserted into the output coupling coil, they will tend to detune the output circuit.

Measurement of H.F. Output

To know the amount of energy that is transferred to the electrode to be heated, one can either use an H.F. thermocouple type of ammeter or, better still, a rectifier type of H.F. instrument coupled to a "Dye" current transformer mounted in the output coupling coil. The trans-

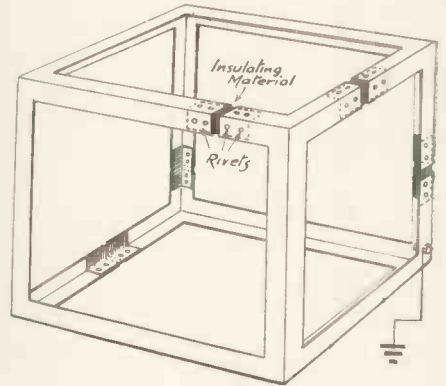

Fig. 7.—Shows the method of splitting a welded angle iron frame of a H.F. generator and linking up the split members with insulating material in order to eliminate circulating current losses. Note: every member of the structure does not require to be split, only sufficient to interrupt any circular paths.

former can be toroidally wound on a ring shaped powdered iron core.

Avoiding H.F. Losses

It is important in constructing the apparatus to exclude the possibility of losses in the metal frame of the generator itself and hence the metal structure is split in several places, thus obviating complete loops in which circulating currents could reach a very high value. The frame itself is interconnected across the split members with pieces of strong insulating material (Fig. 7).

† A thermionic valve voltmeter can be used such as described in October issue of this Journal p. 594.

"Transparency, Colour and Gloss Comparisons"

(Continued from page 626)

light being directed through the specimen instead of being allowed to fall on it. The construction is shown in Fig. 3.

In all cases of light comparison, it is of prime importance that the intensity of the light used should not vary throughout the tests. The actual intensity required is small and a 6 volt 6 watt lamp is usually all that is required. This is supplied

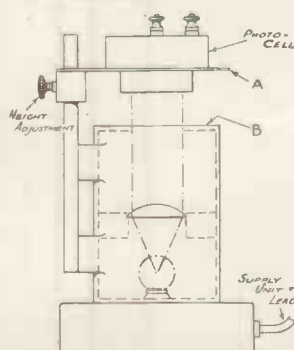

Fig. 3.—Diagram of the Salford transparency comparator.

from an accumulator, which is switched on a few minutes before the readings are taken. In all comparison work it is usual to refer frequently to the original standard, and if this is done any falling off in intensity of the source of light is detected at once.

The instrument unit is separate in the last two cases and comprises a voltmeter for lamp voltage, a moving coil galvanometer calibrated 0-100 per cent. and rheostats for adjusting the lamp voltage.

American Methods of FILM TRANSMISSION

By E. W. Engstrom, G. L. Meers and A. V. Bedford*

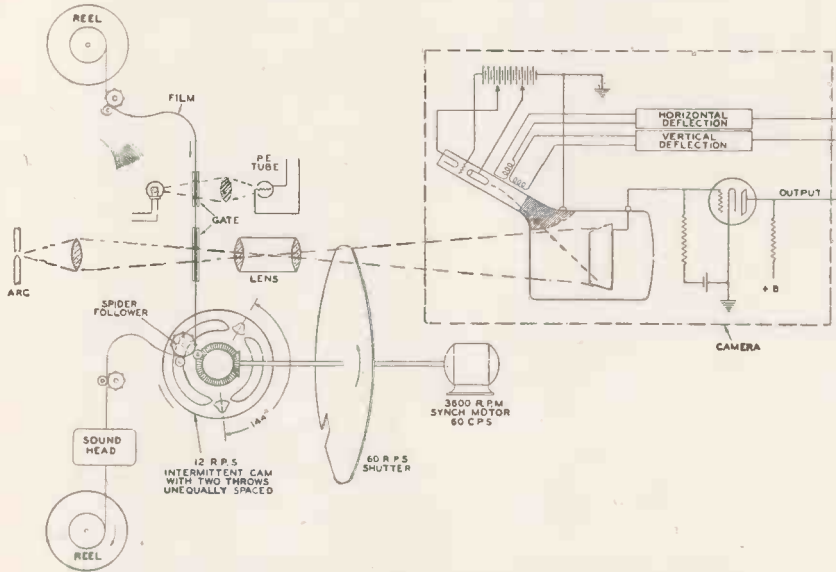

Fig. 1. Schematic diagram of film projector using Iconoscope camera.

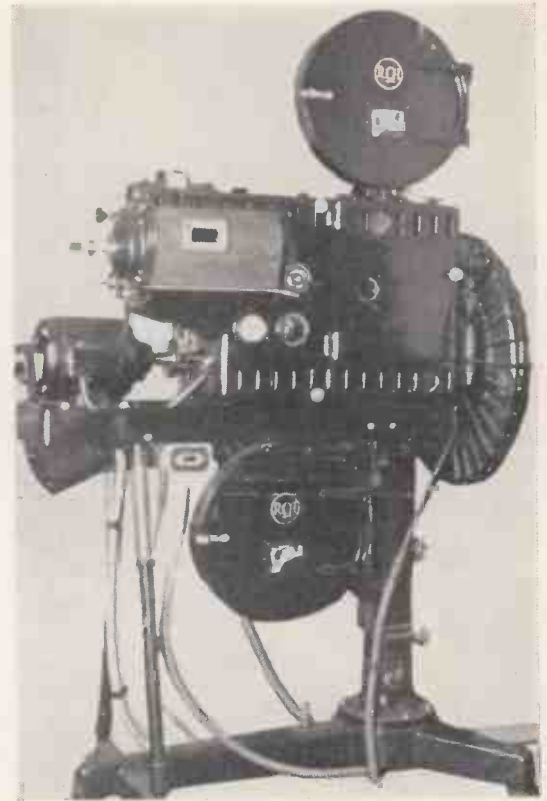

Fig. 5. R.C.A. 35 mm. sound motion-picture projector

THE pickup system, using the Iconoscope, makes use of the principle of storage, whereby, when a particular photo-emissive element is scanned the light which has fallen upon that element since it was last scanned is effective in producing the signal.

A charge image may be built up by a very brief projection of the image upon the photo-emissive mosaic, which is then scanned by an electron beam while the mosaic is dark to produce the signal. The film pull-down occurs during the relatively long interval while the mosaic is being scanned.

Fig. 1 shows schematically an Iconoscope camera and a special projector adapted to project standard 24-frame-per-second film upon the Iconoscope mosaic in such way as to generate television signals according to the Radio Manufacturers' Association (U.S.A.) standards; namely, at 30 frames per second and 60 fields per second, interlaced. The projector must flash a still picture upon the mosaic every 1/60 second with each flash lasting less than 1/600 second. Since the film must run at a mean speed of 24 frames per second for

proper reproduction of sound and motion, it is evident that each frame must be projected more than once to provide the required sixty flashes per second. Since sixty divided by 24 is 2½, it would seem logical that each frame should be projected two and one-half times

This is impracticable, but a very satisfactory method is to project alternate frames of film two and three times each, respectively; for example, the even frames twice and the odd frames three times. Fig. 2 shows the various steps of projection and scanning in proper relative time on a

non-uniform intervals of 2/60 and 3/60 seconds, respectively. Note from this figure that the scanning or transmission times occur *between* adjacent light flashes so that the television picture signal is actually produced and transmitted during periods when no optical image is present on the mosaic. However, during these periods an electrical image is present in the form of bound electrostatic charges on the tiny photo-sensitized silver globules comprising the mosaic. It is the act of neutralising or rather equalising these charges by the electrons of the scanning beam which

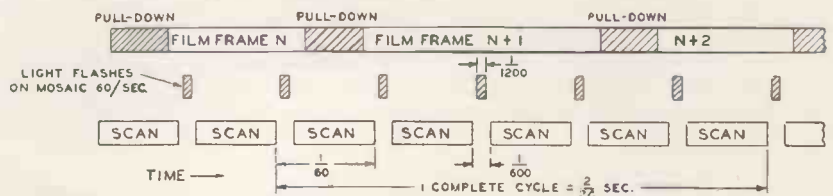

Fig. 2. The various steps of projection and scanning in correct relative time on a horizontal scale.

horizontal time scale. Since the light flashes are very brief, a relatively long (approximately 1/67 second) interval is available between flashes for the film pull-down. However, if the full time available is used, the alternate pull-downs must occur at

causes the useful signal current to flow from the conducting back coating of the mosaic plate.

Referring again to Fig. 1, the film is drawn through an illuminated gate by an intermittent sprocket which is driven by an intermittent cam and

*Journal of Society of Motion Picture Engineers (U.S.A.).

Continuous Projection

spider-follower. The 3,600-r.p.m. special synchronous motor drives the cam at 12 revolutions per second through a suitable gear, thus pulling the film down 24 times per second, since the cam has two "throws" instead of the customary one "throw." In order to pull the film at unequal intervals as required, the "throws" are located 144 degrees and 216 degrees apart, respectively. The film picture in the gate is projected upon the small photo-emissive mosaic of the Iconoscope by a standard projection lens. The light is chopped 60 times per second by a large rotating shutter, located near the lens. The shutter is accurately timed relative to the intermittent cam so that the film

shows that displacing the light flashes $1/120$ second with respect to the scanning periods would cause them to occur during, instead of between, the scanning periods. The abrupt change in mosaic lighting caused by a flash during the scanning period would produce a serious streak across the middle of the picture as mentioned above. To prevent the frequent locking-in of the motor in the wrong position, a special synchronous motor is used which includes an additional d.c. winding for fixing the polarity of the poles and thus determining the lock-in position with respect to the a.c. power supply.

The sound head used is standard, since the mean speed of the film is 24

frames per second. It has been found that a suitable fly-wheel associated with the intermittent cam prevents any detectable deterioration of the reproduced sound due to the dissymmetry of the intermittent cam.

commercial type of theatre projector was used, in which the film passed the picture gate at constant speed and a stationary projected image was obtained by means of an "optical intermittent." This projector employed several rocking mirrors on a rotating wheel. The lens system was properly proportioned for the projection of the small image required for the Iconoscope mosaic plate. In testing this system it was noted that the television performance was limited by various types of movement in the projected optical image and by low resolution.

Motion of the optical image, in addition to causing objectionable motion in the received television picture, also contributed to loss of resolution in the picture. This is due to the storage action of the Iconoscope whereby the signal derived from each element of the mosaic in scanning is due to the summation of all the light which has fallen on that element since the preceding contact of the scanning beam. The effect is similar to that obtained when the optical image on a sensitised photographic plate moves during exposure.

Fig. 3 shows a projection sequence by which an intermittent type projector might project film on an Iconoscope for the entire scanning time provided the pull-down occurred in the almost prohibitively short time of $1/600$ second or less. This would permit projection throughout the entire scanning period. There is no apparatus now available for meeting the $1/600$ second pull-down requirement. If suitable equipment could be developed it is doubtful if the film would withstand the stresses imposed by the rapid motion.

is always stationary when the light flashes occur.

The generator of synchronising signals for the television deflecting system is synchronously controlled by the same 60-cycle power supply which drives the projector synchronous motor. The phase of this signal generator is adjustable so that the operator can make the short duration light flashes fall safely within the $1/600$ -second intervals between the vertical scanning periods with some tolerance on each side for slight phase displacements such as are caused by small changes in the mechanical load on the projector or by voltage variations. This adjustment is very important, as any abrupt change in the illumination of the mosaic during the picture signal transmission time produces a spurious light streak across the received picture.

An ordinary 3,600-r.p.m. synchronous motor has two identical pole structures which can assume either polarity and hence such a motor can lock into synchronism in either of two phase positions, depending fortuitously upon starting conditions. Two such lock-in positions are one-half of a cycle of the power-supply frequency apart in time, which for a 60-cycle power system is $1/120$ second.

Inspection of the diagram of Fig. 2

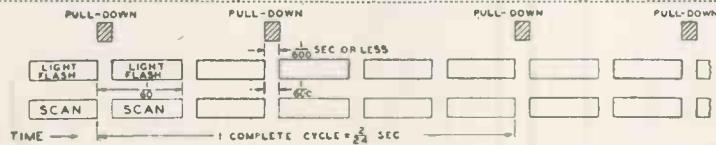

Fig. 3. Projector sequence of an intermittent type projector using Iconoscope.

Other Mechanism

There is some evidence that the television picture transmitted by a system depending entirely upon the storage principle might not be as satisfactory as one transmitted by a system in which the film image is projected upon the photo-emissive mosaic either continuously or during the entire scanning period. It is natural, therefore, that investigations of the latter type of system should have been made. So far, the results obtained have not been wholly satisfactory and certainly have not been as excellent as those produced by the storage method described in the previous section. However, refinement of certain projection methods may at some time in the future make other systems of greater interest. It is, therefore, of value to digress and review some of the various schemes that have been investigated.

For obtaining a continuous and constant light image on the Iconoscope photo-emissive mosaic, a com-

Details of Projector

gate. This resulted in objectionable flicker in the television picture. Also, in spite of the very small amplitude of motion required for the rocking mirror, the cam and follower-roller

tion with the synchronising pulses.

4. An additional film gate with light source and photo-electric cell is included near the picture

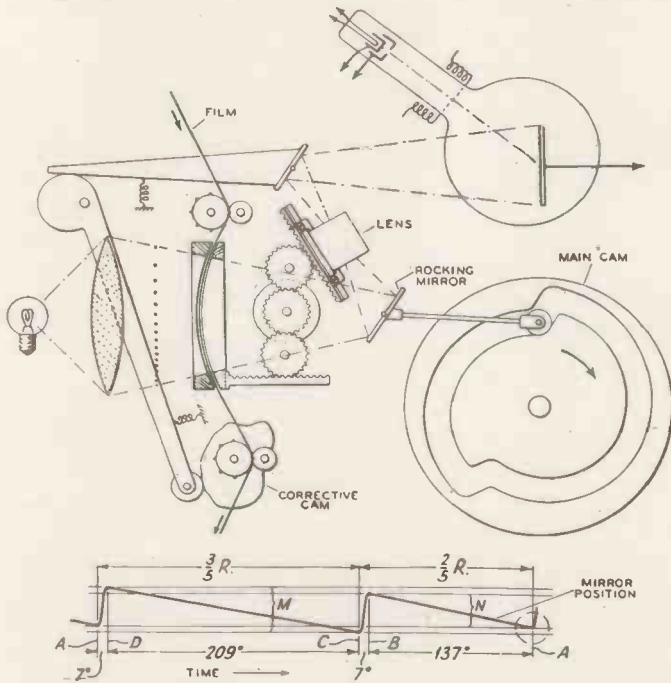

Fig. 4. Experimental rocking mirror projector.

not more than 10 per cent. of 1/60 second or 1/600 second.

In order to make efficient use of the projection lens, it is necessary for the aperture in the shutter to be at least as wide as the diameter of the lens. A large diameter shutter (23 in.) is necessary to meet this requirement. This shutter rotates at 3,600 r.p.m. and has a peripheral speed of approximately $4\frac{1}{4}$ miles per minute. The shutter is enclosed in the circular housing which is shown at the extreme right-hand side of Fig. 5. In the shutter housing opposite the projection lens is a window through which the picture is projected. The shutter disc is made of two overlapping sections of thin metal. These two sections can be rotated with respect to each other through a small angle in order to vary the width of the aperture.

A second gate is located four frames of film above the picture gate. To the left of this gate is a lamp housing. To the right of this gate is a photocell housing which also includes an optical system for forming an image of the lamp filament on the photocell. The output voltage from this photocell is rectified, and after being passed through a suitable filter is used to control the return-line blanking signals. The resultant variation in the blanking signals is used to control the average brightness of the reproduced picture. The pro-

created a very annoying noise and were subject to rapid wear.

Description of Film Projector

It is of interest to return now to the method for using film which is considered best at present, and review the apparatus in more detail. Fig. 5 is a general view of a 35-mm sound motion-picture projector designed for 30-frame-per-second television with interlaced scanning. This projector differs from standard theatre projectors in the following major respects:

1. A special shutter is used to provide efficient light pulses of very short time duration for projecting, 60 times per second, images of the film pictures on to the photo-emissive mosaic of the Iconoscope.
2. The intermittent mechanism is designed for the three-to-two ratio pull-down periods required in using 24-frame film for 30-frame television.
3. A special synchronous driving motor is used to assure that the projector mechanism always "locks-in" in proper time rela-

gate for deriving a control potential which varies with the average density of the film.

In the projector shown it was impracticable to locate the shutter between the light source and the film.

Fig. 6. System for television transmission from motion picture film.

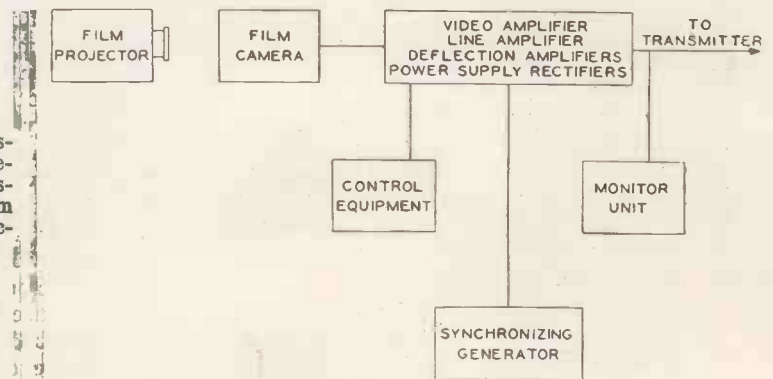

The shutter was, therefore, mounted just beyond the projection lens for focusing. The time during which the image may be projected on to the photo-emissive mosaic of the Iconoscope is limited to the vertical return time of the scanning beam. With present television standards this is

jector is equipped with a small 30-ampere arc.

Equipment for Televising Film

The essential elements of a system for television transmission from motion-picture film are shown in Fig.

6. These include: Film projector; Iconoscope film camera; camera amplifier equipment; control equipment; monitor equipment; synchronising generator.

The Iconoscope camera used with the film projector includes deflecting circuits and a pre-amplifier for the video signals. This pre-amplifier provides a signal level suitable for transmission over a co-axial cable to the camera amplifier equipment. The camera is usually mounted on one side of a wall, with the film projector located on the other side. The picture is projected through a window in the wall into the camera onto the photo-emissive mosaic of the Iconoscope.

The camera amplifier equipment includes apparatus for amplifying further the video signals from the camera and a line amplifier to prepare these signals for transmission over co-axial cable to any desired location. Amplifiers providing suitable wave shapes for horizontal and vertical deflection of the Iconoscope beam are included as well as the power supplies for the several parts of the system.

The control equipment provides

means for varying the video signal gain, the picture brightness, and the uniformity of the picture-background illumination (shading), and for starting and stopping the film projector.

The monitor equipment includes a 12 in. cathode-ray tube by means of which television images obtained from the film can be viewed. It also includes a cathode-ray oscilloscope for observing the wave shapes and amplitudes of the television signals.

The synchronising generator supplies the several complex wave-forms which are required to determine the timing of scanning processes in the transmitting equipment and to synchronise the reconstruction of the images at the receivers. The wave shapes of the synchronising signals have been standardised by the Radio Manufacturers' Association.

Simplified Apparatus

For specialised services, more simple and compact apparatus has been developed. The simplified equipment suitable for producing television signals and television

images from motion-picture film includes all of the elements previously described, but in far more compact form. The equipment, less the Iconoscope camera and the projector, is included in one cabinet approximately 44 in. high, 34 in. wide, and 21 in. deep.

Laboratory work and field-test experience permits some preliminary generalisations on film that has given good results for television. It appears that film having characteristics best suited for theatre projection is also generally best for television. Studio sets having all dark backgrounds should be avoided. A good number of close-ups should be used, but these should be generously interspersed with long shots. Special processing of film does not seem to be necessary. Film photographed in colour directly from real life or nature appears satisfactory for television. Some cartoons in colour have not given particularly satisfactory results. Thus, it appears that there may be no really serious technical problems in the production of motion-picture films suitable for television-programme material.

New Electron Gun Assembly for Cathode-ray Tubes

A RIGID gun assembly in which electrodes are accurately aligned and spaced and at the same time adequately insulated from one another is a vitally essential feature in cathode-ray tube manufacture. A new method of accomplishing these requirements is shown by the drawings and it will be seen that the electrodes are supported from one another by means of intermediate rings

of insulating material to which they are fastened by metal clips or tags. The insulator is preferably of ceramic material, and for axially symmetric electrodes takes the form of a plane circular ring of uniform thickness.

The method is illustrated for two tubes of equal diameter in Figs. 1 and 2. The electrodes are provided with flanges A and B, the flat portions of which rest upon the flat faces of the insulator. The separation between

the electrodes may be set to any desired amount either by a suitable thickness of insulator or by adjusting the position of one of the flanges upon its electrode. The flanges may form an integral part of the electrode as in Fig. 1, or may be attached to the electrode by welding (Fig. 2). Alignment is secured by means of the outer rims of the flanges which fit accurately over the outside of the insulating rings.

Each flange is held in position on the insulator by means of several metal tags T (Figs. 3 and 4) which are bent into appropriate depressions in the outside surface of the ring. These depressions may take the form of a single groove round the ring (Fig. 3), or may be separated as in Fig. 4. Preferably the tags should form a part of the flange instead of being separate pieces joined on by, for instance, welding and the thickness is such that the tags can be bent but yet are reasonably rigid in the bent position. The minimum distance between the ends of the flanges is determined by the degree of insulation necessary: for most purposes one to two millimetres is sufficient.

This construction may be applied to plane or tubular electrodes and although it is especially valuable in the simpler guns such as triodes and tetrodes it may also be used for the more complicated types.

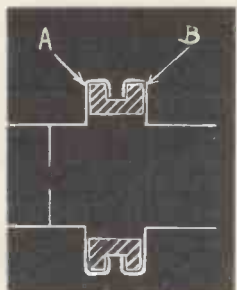

Fig. 1.

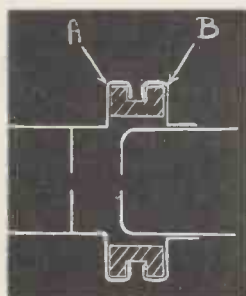

Fig. 2.

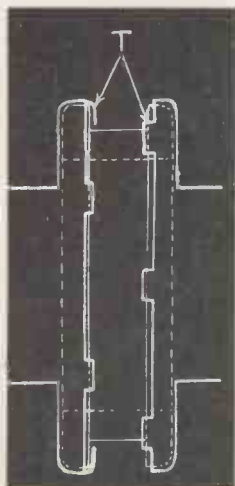

Fig. 3.

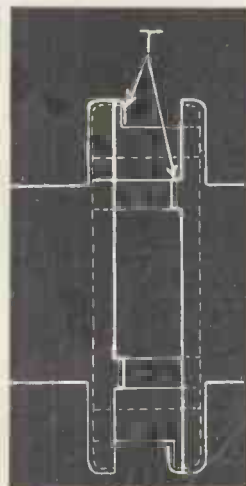

Fig. 4.

Diagrams showing a new method of assembling cathode-ray tube electron gun.

A PHOTO-ELECTRIC INCENDIARY BOMB DETECTOR

Here are details of a war time application of the photo-electric cell for incendiary bomb detection

THE researches of the Baird Company in the field of photo-electric devices over a considerable number of years has placed this concern in an almost unique position to develop apparatus which has particular application under present conditions. Much of this is, of course, of a secret nature but there is one development which it is possible to describe. This is an incendiary bomb and light detector and also a combined light and smoke detector.

There is, of course, nothing new in the detection of light and smoke by photo-electric methods and the Baird apparatus employs conventional principles. The special feature of the device, however, lies in the fact that it is entirely proof against failure. For example, should the mains supply fail, the valve give out, or an accident occur to any of the connections, an immediate warning is given which will persist until the fault has been remedied.

Four models of the device are made, the first a standard general purpose unit intended to be used with a continuous ringing bell having its own local battery. The warning signal is given when the cell window receives its flash of light from the bomb, or in the event of the current supply being accidentally switched off.

The second, model B, has an additional relay circuit whereby the accidental switching off of the power supply will give a visual signal instead of operating the main alarm bell.

We also witnessed a test of a model which, normally operating from the mains, automatically changes over to battery operation should the mains supply fail, or be interrupted.

The two other models are designed for use on D.C. supply and battery operation. In addition a combined incendiary bomb and smoke detector instrument is in course of preparation.

The Baird detector has a special photo-electric cell which is very sensitive to the blue end of the spectrum. It is a vacuum-type cell, connected to a standard valve which is operated from the mains. The anode current from the valve operates a relay in its circuit. The exact circuit is the subject of a patent application and, therefore, cannot be revealed at present.

One unique feature is that the apparatus can be set to operate under any lighting conditions and it will function as an alarm immediately there is any change such as would be

caused by an incendiary bomb or fire. So sensitive is the smoke detector that the slightest trace of smoke, as for example from a cigarette at a distance of a dozen yards, will switch on the alarm.



The Baird photo-electric incendiary bomb detector.

Cathode Location in Valves

IN conventional radio receiving valves of the kind in which the electrodes are mounted between a pair of insulating spacers, difficulty is often experienced in mounting the indirectly heated cathode firmly in one of the spacers to prevent lengthwise movement. Further, if the cathode sleeve is secured at each end, then it has a tendency to bow or buckle at the centre in operation due to longitudinal expansion.

The following idea, which originates with the Radio Corporation of America, suggests a means for mounting cathode sleeves so that they are positively locked against endwise movement at one end and so that they are free to expand without buckling when heated.

Referring to the drawings, the valve shown in Fig. 1 comprises an electrode assembly with insulating

(Continued on page 669)

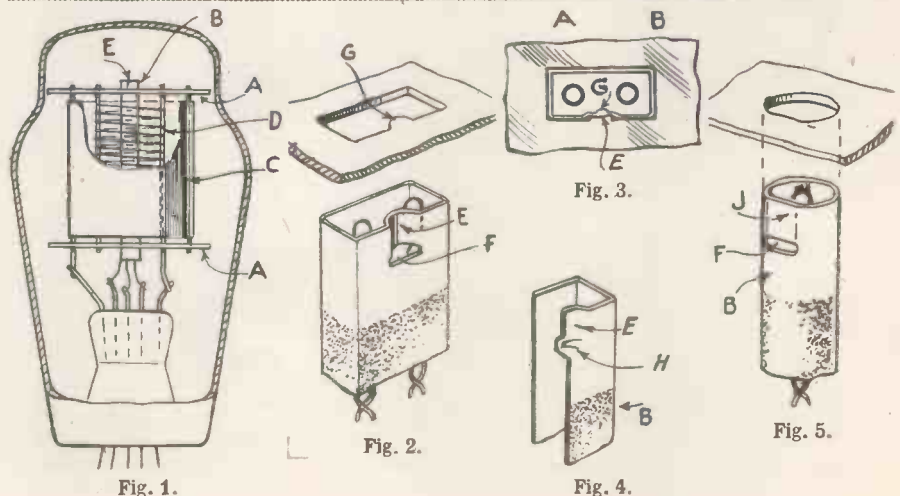

THE ELECTRON RASTER MICROSCOPE

THE development of television has given, and is still giving, a tremendous fillip to the electronic arts. One outstanding case of this is the electron "Raster Microscope," developed by Manfred von Ardenne, the well-known German inventor and physicist.

To understand it, it may be as well to remember the ordinary electron microscope, as evolved by Busch, Ruska, B orries, etc. (See Fig. 1).

The Conventional Electron Microscope

An axially symmetric electric or magnetic field will act upon electrons travelling not too far from the axis through this field in a manner very much like an optical lens.

The electron lens has a focus on either side; that is, electrons travelling parallel to the axis through the lens will combine on the other side at the focus. The distance from the centre of the lens (if it is a thin one) to this point, called the focal distance, is dependent on the geometrical dispositions and is proportional to the velocity of the electrons, and in the case of an electro-static lens, is inversely proportional to the difference of potential of the lens electrodes. In the case of a magnetic lens the focal distance is inversely proportional to the square of the current flowing through the coil. At present electron microscopes are constructed with magnetic lenses. (See Fig. 2). To produce a strong homogeneous magnetic field, the coil is surrounded by a soft iron shielding extending conically towards the centre, but leaving it free. The gap B between the two sides of the shielding should preferably be as large as the centre hole A.

Coils have been built which have, with the maximum current flowing through them, focal lengths of the order of a few millimetres.

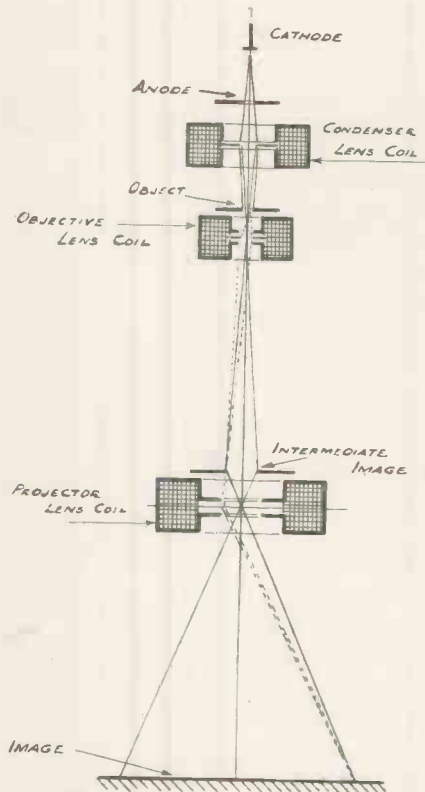

Fig. 1. Diagram of the conventional electron microscope.

Leaving aside other factors, the magnification power of a microscope depends on its focal length. The smaller the latter, the greater the former. Optical microscopes have

This article by **Rudolf Kompfner** explains the operating principles of a new type of electron microscope which gives promise of providing an even higher resolution than that obtained at present with the ordinary electron microscope.

long ago reached their limit of resolution. This limit is determined by the wavelengths of the light employed (and their apertures). No microscope, whether it be optical, electric, or based on any other con-

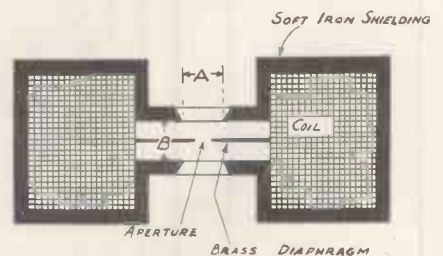

Fig. 2. Diagram of magnetic lens.

EMPLOYING AN ELECTRON SCANNING BEAM FOR VERY HIGH RESOLUTION

ceivable principle, can resolve distances smaller than one-third the wavelength illuminating the object.

With the discovery of the wave nature of electrons, and the fact that the wavelength is a function of the electron velocity, it became immediately obvious that thereby we were given means to extend our range by several orders of magnitude. The wavelength of an electron accelerated by a potential difference of, say, 10,000 volts, is 1.2×10^{-8} mm. compared with that of ultra-violet light at 3×10^{-4} mm.

The limiting factor at present is indeed not the wavelength, but certain lens aberrations and geometrical considerations.

It is not practicable to build and evacuate tubes longer than about 1.5 metres, neither can one accommodate more than two lenses without running into great difficulties. With focal lengths of 3 mm. and image distances of 600 mm. we get two magnifications of 200 each and a total magnification of $200 \times 200 = 40,000$. The rest of the tube is taken up by the electron source usually a cold cathode in a separate discharge tube, accelerating the electrons up to 50,000-60,000 volts.

The object—microbes, tissues, etc.—are fixed on an ultra thin membrane contained in a sort of cartridge, and inserted into the tube through an airlock. The electrons are shot through the object and form an image on a fluorescent screen or on the photographic plate. In the latter case another airlock has to be provided.

The fact that the object has to be brought into the vacuum is a drawback. It is true that it takes only a few minutes to do; nevertheless, together with keeping vacuum pumps and high tension supply going, not to speak of the very critical adjustment of the focal lengths of the coils, it requires high skill and concentra-

How The Electron Raster Microscope Functions

tion. To be able to leave the object which is to be examined outside the microscope tube, in the air, would be an advantage.

It is for this reason, and because of the promise of a resolution ultimately higher than that of the conventional electron microscope, that the development of von Ardenne's raster microscope is of special interest. (See Fig. 3.)

The Principle

Its principle is as follows: A very thin electron beam is produced having a cross section less than 10^{-5} mm. and is made to scan the object in successive lines, in a "raster," just as in television. The electrons, after passing through the object and the membrane holding it, suffer in different degrees, either scattering, slowing down or being absorbed, according to the density or thickness of the object and they impinge on a collecting electrode in corresponding quantities. The resulting current impulses may be amplified in the same manner as with the Iconoscope and reproduced on the fluorescent screen of a cathode-ray tube, whose electron beam is made to move in synchronism with the electron pencil in the raster microscope.

This is only a very general description, intended to give the reader the rough idea.

As carried out in practice an indirectly heated oxide cathode together with a negatively charged "Wehnelt" cylinder and accelerating anode, are used to produce the initial electron beam. The cross section of the beam at the so called "first crossover" is somewhere about 10^{-1} mm. and this crossover is imaged by a magnetic lens similar to that of the ordinary electron microscope, and reduced 200 times. This is repeated once, so that there is now an electron pencil near the focus of the second lens of a cross section of about $2 \cdot 10^{-6}$ at its thinnest point. At some point between the two lenses is the deflection system (magnetic or electrostatic) and scanning pulses applied thereto will result in a scanning movement (in opposite directions, of course) of the electron pencil.

The current of the electron pencil has to be kept very small because of the repelling influence which the elec-

trons have on each other, tending to enlarge the smallest cross section. Its actual strength for a smallest diameter of $2 \cdot 10^{-5}$ mm. is 10^{-14} amp. If we desire a picture of 200,000 points, corresponding roughly to the present television picture definition, and a contrast of 1:10, we need one second for illuminating each picture

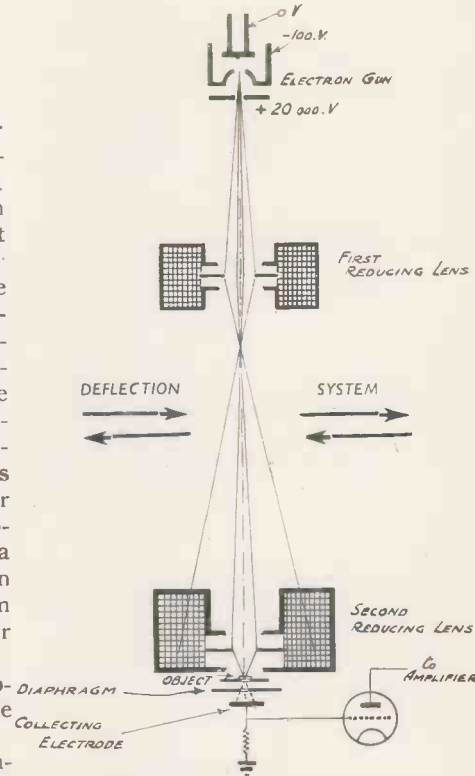

Fig. 3. Diagram of electron raster microscope.

element and several hours for scanning the whole picture.

This, of course, rules out any system of direct vision on the screen of a cathode-ray tube, and makes it necessary to employ photographic plates.

For direct observation on a cathode-ray tube, the maximum resolution is 10^{-3} mm.

If the tube is terminated immediately after the second lens and a so-called "Lenard-window" inserted in the path of the electron pencil, the object can be scanned in free air. The collector is arranged directly underneath.

A "Lenard-window" is nothing but a very thin membrane, usually of aluminium about $5 \cdot 10^{-5}$ mm. thick, of a diameter of, say, $4 \cdot 10^{-2}$ mm.,

which allows the passage of electrons, disturbing their paths only very little.

Electrons on their passage through matter are influenced in several ways. After proceeding for a certain distance substantially in their original directions, they spread out in all directions while,

(a) They are slowed up in various degrees.

(b) Scattering takes place.

(c) They may be absorbed completely.

Complete absorption only takes place when the matter is sufficiently dense or thick.

The length of the path through which the electrons retain their original directions, is roughly directly proportional to the beam velocity and inversely proportional to the thickness and density of the matter, and is called the "Parallel-path." The density of the matter is expressed by its atomic weight. Thus the parallel-path of a beam of 40,000 volt velocity through ordinary air is 0.1 mm. long, through air of 3 mm. Hg. pressure is 30 mm. and through aluminium = $4 \cdot 10^{-5}$ mm.

Three mm. of air at atmospheric pressure are sufficient to stop the beam completely. It is thus apparent that it is quite feasible to have the object in the open air, fixed on the upper side of a thin membrane (organic substance, about $3 \cdot 10^{-5}$ mm. thick).

Image Production

By different arrangements of the collecting electrode or electrodes one can choose whether to produce an image from a transparent object (quasi diasopic) or from an opaque object (episcopic) or with dark background illumination. (See Fig. 4.)

A very ingenious proposition is to use a photographic plate directly as the registering medium and to move this plate in synchronism with the impulses deflecting the electron pencil. Thus it is possible to utilise the high energy content of the electrons as well as their numbers.

The blackening of the emulsion will be proportional to the product of energy times numbers of electrons, and will appear as a very thin line. With a definition of 400 lines the complete image will be about the size of a postage stamp, to be enlarged afterwards.

Aberrations and Resolution

It will be interesting to have a look at the various aberrations and see whether and how far they set a limit to the resolution which can be obtained with the electron raster microscope.

(1) The first to consider is diffraction, which limits—even with apertures as small as $1/100$ —the resolution at $5 \cdot 10^{-7}$ mm. (Beam velocity 50,000 volt.) Neither does diffraction limit the resolution of the ordinary electron microscope.

(2) The second aberration would result from the space charge effect in the point of the electron pencil and to avoid it the beam current has to be kept as small as 10^{-14} amp. to attain maximum resolution. In this regard the ordinary electron microscope seems to have a decided advantage over the Raster microscope.

(3) There is no electronic lens free from spherical aberration, neither can it be completely corrected. With lenses as they are at present, it limits the resolution at $2 \cdot 10^{-6}$ mm. The spherical aberration increases with the aperture, but it is claimed by Borries and Ruska for the ordinary electron microscope that the actual aperture under which the electrons coming from the object enter the first lens is very much smaller than the aperture as represented by lens opening and focal distance. In their opinion, moreover, contrast of the image, and even the image itself, is due to the fact that electrons which suffer scattering in the object greater than the objective lens aperture do not reach the image at all.

(4) Chromatic aberrations are represented at electron lenses as variations in the velocities of the electrons and can be very serious.

Critical Potentials

If the accelerating potential is 50,000 volt. and the diameter of the objective $5 \cdot 10^{-2}$ mm. the potential must not vary more than by ± 1 volt. if the resolution be somewhere about 10^{-6} mm. As this potential is usually produced by rectification of an alternating current, very large reservoir condensers for smoothing to such an extent are needed. The writer of this article wonders whether superimposing an alternating current of the same frequency and the same relative strength on the direct current flowing through the coils, would help

to diminish this aberration. Despite the fact that the lens focus follows a "square" law, in a first approximation the effect would be compensatory.

Another chromatic aberration is due to the initial divergence of velocities of the electron source. This is for thermionic electrons between .1 and 1 volts, and therefore harmless. For electrons generated in a gas discharge

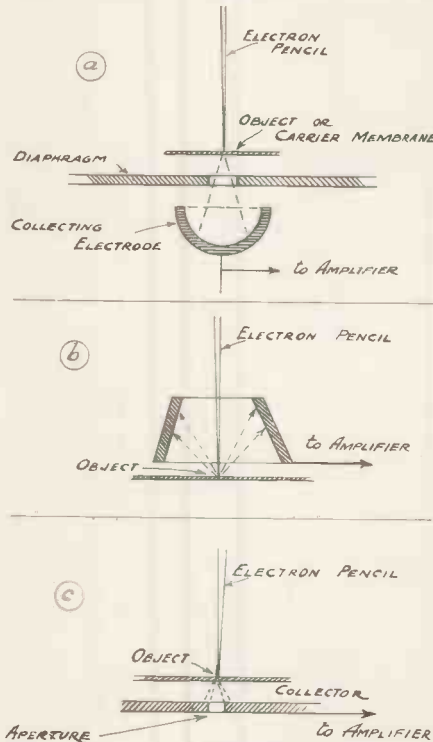

Fig. 4. Diagrams showing how the raster microscope can be used for different types of observation. a. Transparent object; b. Opaque object; c. Dark background illumination.

tube it would be considerably more—up to 10 volts.

Still another chromatic aberration is effected in the object itself due to the differential slowing up of electrons in matter. It severely limits the resolution attainable with the conventional electron microscope, especially if the object is a slice of tissue, as one cannot cut slices thinner than $5 \cdot 10^{-4}$ mm.

But with the electron raster microscope, this aberration can be completely neglected if the layer of the object which is to be examined is assumed to be the top layer. What happens to the velocities of the electrons after they have gone through the top layer does not matter. Manfred von Ardenne claims that under

these circumstances his electron raster microscope is capable of a twelve-fold increase of resolution.

Electric and chiefly magnetic stray fields which are always present in towns would be quite strong enough to play havoc with the resolutions of electron microscopes. Therefore they have shields of high permeability surrounding them completely.

To arrive at the probable total resolutions, one should take the square root of the sum of all the various part-resolutions. Looked at in that way, the maximum resolutions for the electron microscope and the electron raster microscope are 10^{-5} mm. and 2×10^{-6} mm. respectively, at beam velocities of 50,000 volt. But this has to be taken with a grain of salt as nature does not always perform according to formulæ and as both forms of microscopes are still in a state of development.

Developments might turn in several directions. Electrostatic lenses might be developed which have focal distances of a few millimetres. Lenard-windows might be fitted to the conventional electron microscope. The electron source for this might be made completely independent from the microscope, both evacuated and sealed off once and for all.

By arranging very much smaller apertures than are used at present, better use could be made of the diverse scatterings of the electrons in the object, thus increasing the contrast of the image.

References

- Übermikroskop*, by B. von Borries, E. Ruska, in *Wissenschaftliche Veröffentlichungen aus den Siemens Werken*, Folio XVII, February, 1938, p. 99.
- Auflösungsvermögen des Elektronen-Mikroskops*, by Manfred von Ardenne in *Zeitschrift für Physik*, Folio 108, p. 338.
- Das Elektronen-Raster-Mikroskop*, by Manfred von Ardenne, in *Zeitschrift für Physik*, Folio 109, p. 553.
- Die praktische Ausführung des Elektronen-Raster-Mikroskops*, by Manfred von Ardenne, in *Zeitschrift für technische Physik*, 1938, p. 402.
- A new Electron Microscope*, by L. C. Martin, Whelpton & Parnum in *Journal of Scientific Instruments*, 1937, p. 15.

CHARACTERISTIC IMPEDANCE OF FEEDERS

ALIGNMENT CHART

By Norman C. Stanford

This chart is for the determination of the characteristic impedance, Z_0 , of parallel wire feeders at radio frequency. Derived from the expression: $Z_0 = \sqrt{L/C}$, where L and C are the inductance and capacitance respectively of the feeder per unit length.

A straight line joining the points marking the appropriate values of wire gauge and feeder spacing, on the outer lines, will cut the centre line at the point corresponding to the value of Z_0 .

Photo-cell Control for Depositing Metal

THE efficiency of a transparent photo-cathode is, of course, largely determined by the thickness of the conducting layer on which the photo-cathode is formed, and the technique of depositing such layers with an accurately controlled thickness is in consequence highly important.

Although it is possible to deposit these layers by manual methods, automatic methods capable of higher accuracy are clearly preferable, and one

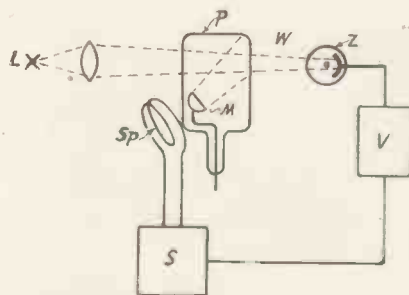

Scheme for photo-cell control in producing photo cathodes.

such method is as follows: The basic idea is that the vaporisation of the metallic substance which is to form the layer is controlled in accordance with the transparency of the layer itself. Referring to the accompanying figure, P indicates a photo-electric

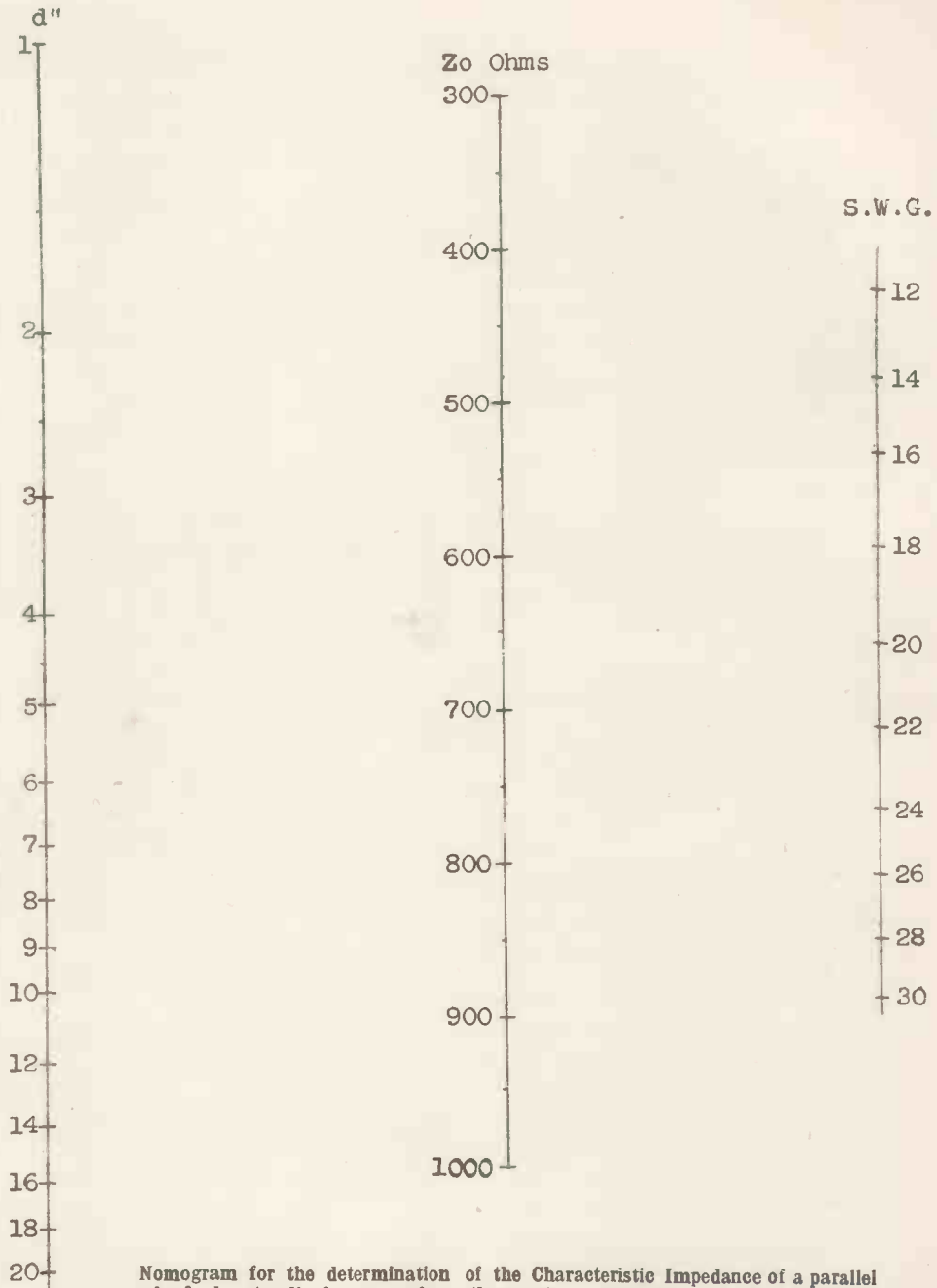

Nomogram for the determination of the Characteristic Impedance of a parallel wire feeder at radio frequency from the spacing d in inches and the wire gauge.

cell whose wall W has to be provided with a transparent cathode, M is a metal capsule containing the material to be vaporised, S is a high-frequency oscillator feeding the coil Sp. The vaporiser is thus heated by high-frequency eddy currents.

The control arrangement consists of the light source L, the photo-electric cell Z and a D.C. amplifier V, the output of which is connected in a suitable way with the high-frequency oscillator. The control device is arranged in such a way that when the

glass wall W is clear, the oscillator gives its full output so that the vaporisation process starts. As vaporisation proceeds the intensity of the light falling on the photo-electric cell diminishes and the amplitude of the high-frequency oscillations is caused to be decreased so that by suitable adjustment of the bias and the amplification of the amplifier V the vaporisation process may be interrupted when the desired transparency has been reached.

(Continued on page 640)

DESIGN FOR A SENSITIVE A.C. SHORT-WAVE ADAPTOR

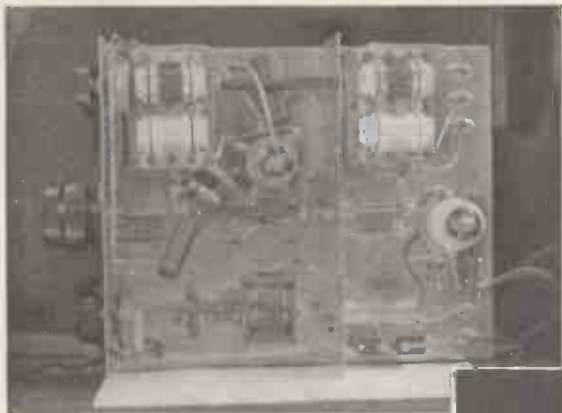

This is a particularly sensitive unit which can be used in conjunction with an existing broadcast receiver or L.F. amplifier for reception of short-wave transmissions.

Fig. 1 (left). A general view of the Adaptor.

Fig. 2 (below). The R.F. stage. Note the stand-off insulators used as terminals and the small trimmer across the tuning.

IN the design of this adaptor the problems of sensitivity, selectivity, and ease of operation have all received their full share of attention, and the result is an adaptor which, in conjunction with a suitable L.F. amplifier, is capable of an exceedingly fine performance.

The Circuit

The circuit comprises an R.F. amplifier and preselector consisting of a 12—60 metre wavechange coil assembly, tuned by a 160-mmfd. condenser, in conjunction with an R.F. pentode of high efficiency. A small amount of feedback is permitted in this stage, providing extra sensitivity and selectivity.

The gain of this stage is controlled by the variation of screen voltage on the R.F. pentode by means of a potentiometer across the H.T. supply. This stage provides gain down to about 20 megacycles, removes the dead spots, and greatly improves the selectivity. The output from this stage is fed to the primary of the detector stage coil, through which the R.F. pentode obtains its H.T. supply.

The detector is also an R.F. pentode, with regeneration, and to ensure smooth reaction throughout the entire tuning range, both a slow-motion reaction condenser and a screen potentiometer are provided. The screen voltage on the detector is set to give smooth reaction on the frequency desired, and the condenser is used to effect further control.

Both the waverange switching and the tuning condensers are ganged, a small trimmer being connected across

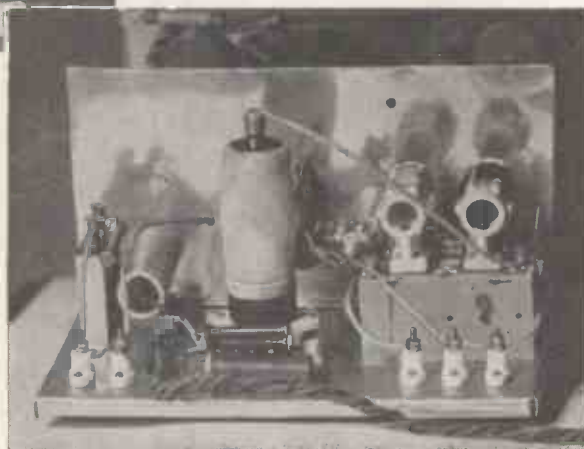

- 2—Extension outfits, type 1008 (Eddystone).
- 7—Midget stand-off insulators, type 1019 (Eddystone).
- 1—Slow-motion driving head (Eddystone).
- 1—Dual speed Dial (Eddystone).
- 1—Component mounting bracket (Peto-Scott or Bulgin).
- 18-gauge tinned copper wire.
- Systoflex.
- Screws, etc.
- Phones (Ericsson).
- VALVES.**
- 2—Type AC/VP1 (Mazda).

COMPONENTS

COILS.

- 4—Frequentite coil forms and bases, type 1090 (Eddystone).

CONDENSERS.

- 2—160 mmfd. variable, type 1131 (Eddystone).
- 1—200 mmfd. reaction, type 957 (Eddystone).
- 1—Trimmer, type 979 (Eddystone).
- 1—.0001 mica (Dubilier).
- 1—.25 mfd. (T.M.C.).
- 4—.1 mfd. tubular (T.M.C.).
- 2—.01 tubular (T.M.C.).
- 1—10 mfd. electrolytic, type 402 (Dubilier).

RESISTANCES.

- 1—200 ohm type 1 watt (Erie).
- 1—5,000 ohm type 1 watt (Erie).
- 1—75,000 ohm type 1 watt (Erie).
- 1—100,000 ohm type 1 watt (Erie).
- 1—25,000 ohm type 1 watt (Dubilier).
- 1—3 megohm type 1 watt (Dubilier).
- 2—100,000 ohm potentiometers (Dubilier).

SUNDRIES.

- 1—Wooden baseboard, 12 by 10 ins.
- 1—Piece 26-gauge aluminium 12 by 10½ ins. (Peto-Scott).
- 2—Pieces 20-gauge aluminium 10 by 5½ ins. (Peto-Scott).
- 2—Battens ¾ by 9 ins.
- 2—7-pin valve holders, type 1075 (Eddystone).
- 1—Screened R.F. choke, type (Eddystone).
- 1—Flexible coupler, type 11003 (Eddystone).

the R.F. tuning condenser for ganging purposes. A slow-motion drive is attached to these condensers and provides easy and accurate tuning.

The general layout of the set may be seen from the photographs, Figs. 1, 2 and 3. It will be seen that the insulation is almost totally ceramic, and losses are thus reduced to a minimum. Even the usual aerial and earth terminals have been dispensed with and frequentite stand-off insulators used in their place. The large tubular electrolytic condenser mounted on the screen between the two stages is the cathode by-pass for the first valve and is of 10 mfd capacity.

The R.F. Stage

Fig. 2 is a view of the rear of the set, and shows the R.F. stage. The trimmer can be seen between the valve and the coils; it is mounted by short wires on the coil unit itself. Three terminals will be seen in front of the coil unit; the two outside ones are connected to the ends of the primary

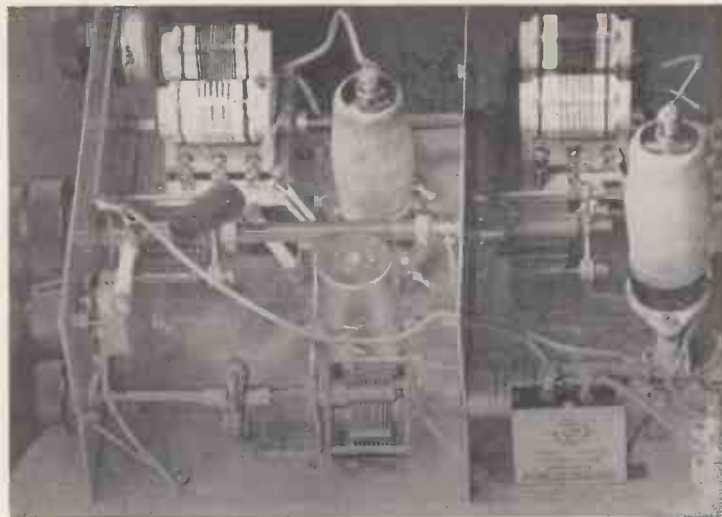

Fig. 3. Showing the arrangement of components in the detector stage.

of the coils, permitting the use of a dipole if desired. When an ordinary aerial is in use, a shorting link is connected between the middle (earth) and outside terminals. This may be seen in position in the photograph.

Fig. 3 is a close-up of the adaptor, and shows the reaction condenser on its extension spindle, which eliminates hand-capacity. The two terminals on the right of this photograph are the output (nearest camera) and H.T. positive respectively. The .25 mfd. T.M.C. condenser next to them is in series with the output lead, enabling the adaptor to be connected to the pickup terminals of an existing receiver.

In Figs. 1 and 3 the positions of the screen potentiometers may be seen: the one nearest the camera controls the screen volts on the R.F. valve, the other controls the detector screen voltage as already described.

The photographs and theoretical circuit provide sufficient indication of

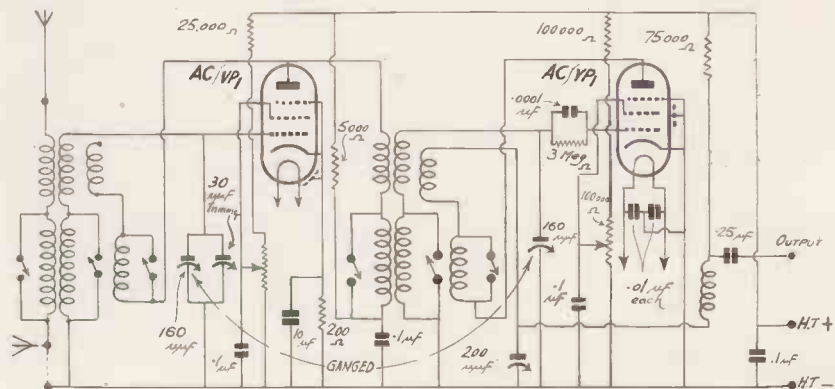

The theoretical circuit of the Adaptor.

the construction. The resistors are all mounted in the wiring, as are the .1 mfd fixed condensers. There are four leads running underneath the baseboard, these being the two heater leads to the detector valve, the lead joining the two coil units, and the lead from the nearest potentiometer

that those in the original model are exceedingly short. 26-gauge aluminium is used to cover the baseboard, and 20-gauge for the panel and inter-stage screen.

The adaptor may be used with a pair of phones connected to the output and H.T.— terminals.

“Photo-cell Control for Depositing Metal.”

(Continued from page 638)

The control of the high frequency transmitter by the output of the photo-electric cell amplifier may be effected by means of gas discharge valves.

The same method may, of course, also be applied to vaporisation from heated filaments. In this case the heating current is controlled by means of gas discharge valves operating under the control of the output of the photo-cell amplifiers.

Mathematical Type

A correspondent writes anent the paragraph on mathematical typewriters in the October issue that he thinks readers will be interested to know that it is possible to obtain type faces cut to any specified letter, Greek or otherwise, at a reasonable cost.

The majority of typewriters, he says, have two keys which can be spared—for instance—the fractions on a standard commercial machine. These can be replaced by a 2 and a 3 above the line as shown, and a π and ω . The required symbols should be drawn four times full size and submitted to a typewriter manufacturer.

The typefaces cost 2s. 6d. each and are easily soldered into place. To obtain the correct alignment they can be fitted loosely on the type level and held in the jaws of the guide in front of the paper.

Books Received

“Static and Dynamic Electricity” by William R. Smythe. Published by The McGraw-Hill Book Company, Inc., London, W.C.2. 40s. (A review will be published next month.)

“Radio Service Trade Kinks” by Lewis S. Simon. Published by The McGraw-Hill Book Company, Inc., London, W.C.2. 20s. (This publication deals with American receivers.)

Electric Discharges at Low Gas Pressures

D. Gabor, Dr.-Ing.

British Thomson-Houston Co., Research Laboratory

IT is unnecessary to emphasise the technical importance of gas discharges to engineers. Yet it is not so very long ago that gas discharge devices were physical instruments, regarded by engineers somewhat contemptuously as laboratory toys. It is interesting to recall the words of Pichelmayer, one of the older generation of electrical engineers, who in his time was considered a great authority; only thirty years ago he wrote: "There is much talk of electrotechnics taking entirely new ways. Yet we hope that at least the most urgent problem of

In return, this knowledge has given us a thorough understanding of gas discharges, and enables us to build them up synthetically from the atomic elements, a course we intend to follow in this article.

The discovery of X-rays, made by Röntgen in 1895, also in a gas discharge tube, opened another great chapter of modern physics, dealing with the crystalline structure of solids.

The Elementary Particles

Let us consider first the protagonists in the play (see Fig. 1). The signs chosen to represent the elementary particles are, of course, purely symbolical. The electron is shown as a white circle, the nucleus as a black dot. There are 92 different kinds of nuclei, corresponding to the 92 chemical elements. They differ from each other in their atomic positive charges. For some reason 92 is the practical limit of the number of elementary charges that can form a stable nucleus. The heaviest atoms, thorium and uranium, suffer already from slow decay, called radioactivity. Under ordinary conditions, every nucleus surrounds itself with as many electrons as are required to neutralise its charge and form the atom, shown as a grey sphere to indicate its electrical neutrality. If we take off one or two of these electrons, we obtain a positive ion, shown as a black sphere. There are also negative ions, atoms which have one or more electrons attached to them. These, however, form readily only in gases of little technical importance such as

chlorine or oxygen, and in the following we will consider the ion always as positive.

Two or more atoms can coalesce, so as to form molecules. They can do this by sharing some of their electrons (homopolar or covalent combination), or one atom can seize an electron from the other, so that the molecule is composed of oppositely charged ions. The technically im-

- Electron Charge $-e = 1.6 \cdot 10^{-19}$ coul
Mass $m = 9 \cdot 10^{-28}$ gr.
- Nucleus Charge $+92e(+)$
Mass $(1-238) \times 1842 m$
- ⊗ Atom Nucleus + Z electrons
- Ion Atom - 1, 2... electrons
- ⦿ Molecule 2, 3... atoms, bound together by 1, 2... electrons

Fig. 1.—The Elementary Particles.

the day, the problem of electric traction, can be solved without electric locomotives driven by Geissler tubes." Had Pichelmayer lived a little longer, he could have seen electric locomotives driven, if not by Geissler tubes, at least by their direct offspring, the steel tank rectifier.

Whereas gas discharges are daily growing in technical importance, their scientific interest has somewhat faded in the last few decades. Historically, the scientific importance of gas discharges is enormous. It is hardly an exaggeration to say that by far the greater part of modern atomic physics has developed out of the study of gas discharges. The electron and the proton have been discovered in gas discharges, and these discoveries—added to the knowledge of the spectra, also produced by gas discharges—have led to our present knowledge of atomic constitution.

WAR-TIME ECONOMY

During the present emergency it is absolutely essential to conserve supplies of paper and facilitate distribution. Readers, therefore, are earnestly requested to ask their newsagents or bookstalls to reserve a copy of this journal for them each month or alternatively place an order for regular delivery.

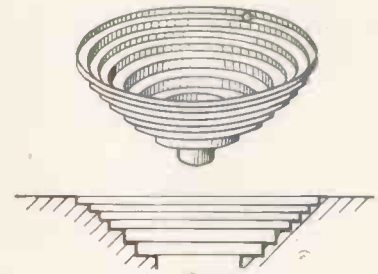

Fig. 2.—Model of atom.

portant gases are mostly monatomic (inert gases and metal vapours) or have covalent combination (H_2).

Now let us have a closer look at the atom (see Fig. 2). Here, however, modern physics say: "Stop! You cannot have a closer look at the atom, you cannot tell what it looks like. You can only describe its pro-

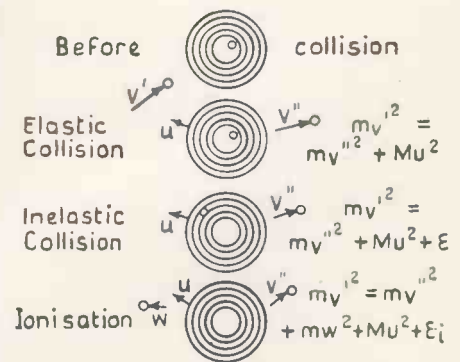

Fig. 3.—Collisions of first kind.

erties, and they are such that you cannot draw a picture of the atom." Therefore, I prefer showing you a model of the atom, that will not tempt us to imagine that it is a picture of the atom. This model (Fig.

* Lecture delivered before the Rugby Engineering Society.

Ionisation

2) is a stepped bowl, or, as scale does not matter in models, a Roman amphitheatre. On one of its steps there is an electron.

There are, of course, several electrons in most atoms, but it rarely happens in gas discharges that more than one comes into play. The model shows us that this electron can be at different energy levels, or in different states. The lowest level, the bottom of the bowl, is called the ground state. An undisturbed atom is either in this state, or it will return to it if we leave it alone. The other levels all have higher energies.

The steps between them become smaller near the edge, indeed they become infinitely small, but this, of course, could not be shown in the drawing. If the electron is in one of the higher states, we call the atom excited. If the electron somehow obtains so much energy that it is lifted above the rim of the bowl, it is free to move wherever it likes. We call this ionisation.

The Elementary Processes

Now let us see how we can make the electron bounce up and down the steps, or fly out of the atom. The simplest method is to knock the atom with a free electron. Let us assume that before the collision the atom was in its ground state (Fig. 3). Three things might happen.

First of all it is possible that the inner state of the atom may not be changed by the collision. In this case the atom behaves in the collision like a solid elastic body. It will obtain a certain velocity, and the electron will lose a little. It will, however, lose very little, as the mass of the electron is extremely small compared with the mass of the atom. The electron will lose a proportion of its energy roughly of the order m/M (m = electron mass, M = atomic mass). This ratio is about $1/1850$ in the case of the hydrogen atom, and about $1/350,000$ in the case of mercury. The energy loss is therefore extremely small, and but for a few exceptional cases we can leave it out of account in gas discharges.

It may happen, however, that by the collision the inner state of the atom is changed, and that after the collision the electron in the atom will occupy a higher level. The energies that can be exchanged in such

"inelastic" collisions are mostly of the order of a few volts. As in gas discharges, we are mostly concerned with electrons of only a few volts velocity, these inelastic collisions are of very great importance.

Finally, the electron may be lifted clean out of the atom. This is called ionisation. By this process two new

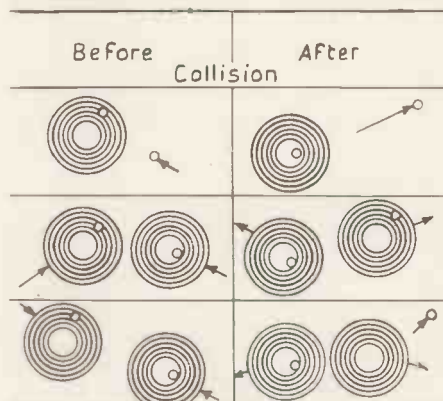

Fig. 4.—Collisions of the second kind.

particles are formed, an ion and a slow electron.

We may ask now, what prevents the electron, after having been separated from the atom, from recombining with the ion? It is prevented by its own energy. It cannot occupy any level in the atom unless

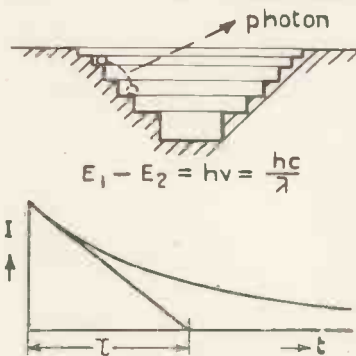

Fig. 5.—Light emission.

it has exactly the amount required, and first it must get rid of the surplus. This is possible, however, only if a third party is present, which can take it over. This may be a third particle, or it may be a solid wall.

In low pressure discharges triple collisions are very rare, and therefore recombination is almost exclusively confined to the walls. This is a fact of fundamental importance, and one of the main differences be-

tween high pressure and low pressure discharges.

These processes, in which an impinging electron imparts energy to an electron bound in an atom, are called collisions of the first kind. Let us turn now to the opposite processes called collisions of the second kind, in which an excited atom loses energy by a collision (Fig. 4). There are again three important cases. If the excited atom collides with an electron, the atom may be in the ground state after the collision, and the electron carries away the energy difference. A second case is when an excited atom collides with another that is in the ground state. They might exchange their energies so that after the collision the one that was previously in the ground state will be excited.

Of course, if the atoms are of the same kind it will look as if nothing has happened, as it is impossible to tell one atom from another. But a similar process is possible with atoms of different kinds. The classic instance is mercury and thallium. If excited mercury atoms collide with thallium atoms, thallium will emit its characteristic green light. This is called sensitised fluorescence.

Finally an excited atom may ionise another. An important practical example is the ionisation of argon or mercury by excited (metastable) neon atoms*.

In all these examples it was always the energy of an electron that excited or ionised an atom, whether the electron was free or bound in the striking atom. We could ask whether it is possible to produce such effects simply by the shock of an atom or of an ion. This is indeed possible, but the energies required are so high that this process plays hardly any part in the gas volume of the discharges. A similar process is, however, of great importance in the glow discharge at cold cathodes, where the electrons have to be knocked out by fast positive ions.

Light Emission

What happens now if the excited atom is left alone? The answer is given in Fig. 5. After some time the electron will fall to a lower level,

* Strikingly demonstrated in the "Penning effects," see Ztschr. f. Phys. 46 335 (1928), 57 723 (1929), 72 338 (1931).

Radiation

and the difference in energy will be radiated in the form of a photon or light quantum. The frequency of the light emitted is directly proportional to the energy difference (Bohr's relation). The fact that every atom has its characteristic spectrum is a natural consequence of the existence of "steps" or of separated energy levels.

To the question "When will the photon be emitted?" modern physics gives a very interesting reply. It confesses that it cannot tell: it may happen immediately after the excitation or in a year's time; there is always the same constant probability of it happening. This is a very puzzling answer, full of deep philosophical implications.

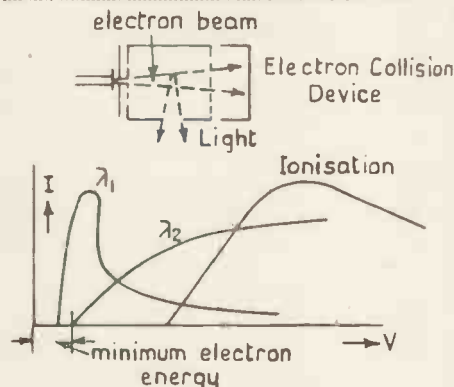

Fig. 6.—Excitation curves.

From the practical point of view, however, the reply is completely satisfactory. If only we know the probability, we can tell how a great number of excited atoms will behave, although the behaviour of each individual one remains uncertain. From a great number of excited atoms the same fraction will emit photons in every unit of time. This results in a law of exponential decay, the same as for the radioactive elements.

The time constants of excited atoms are mostly very short, of the order of 10^{-8} seconds. You may ask how it is possible to observe the law of decay in such extremely short times. There are several ingenious methods, but one of them, due to W. Wien, is particularly direct and beautiful. A small hole is drilled in the cold cathode of a high voltage gas discharge tube. The space behind this cathode is evacuated by means of high speed pumps. Ions and atoms that have been hit by ions

and have thus acquired high velocities shoot through the small hole in a thin luminous beam. The velocity of these atom beams can be made so high that a time of 10^{-8} sec. can be observed easily as a length of several mms. The exponential decay in time becomes immediately visible to the eye as an exponential fading-out of the beam with the distance from the hole. Some atomic states have longer lives, especially the "resonance" lines. The longest are those of the cadmium and zinc resonance lines 3261 Å and 3076 Å, which are 2.5×10^{-6} seconds and 10^{-5} seconds, respectively.

There is, however, a group of atomic states with a very different order of lives. These are called the metastable states, the lives of which are of the order of 0.1 to 10 seconds, enormously long as measured on the atomic time scale, so long that the atom has no chance to remain undisturbed until it emits a photon. In such long periods the atom will collide at least many thousand times with other gas atoms, even in the most diluted gas discharges, or it will reach the wall. Consequently spectral lines corresponding to transitions from a metastable state are never observed in gas discharge tubes.

By reason of their long lives, however, metastable atoms are of very great importance in gas discharges. They form a kind of separate gas, which is more easily ionisable than the normal gas, and plays a very great part in conducting the current. A particularly notable example is neon. With a little exaggeration one may say that the gas that emits the well-known red light in the neon tubes is not neon, but metastable neon.

The most convenient devices for studying collision processes and their consequences are the collision tubes, as shown schematically in Fig. 6. An electron beam of controlled velocity and small intensity is shot into a very diluted gas. This arrangement is due in principle to J. Frank and G. Hertz (1914) and most of our present knowledge of elementary processes has been obtained by their method.

One application of such a device is the measurement of the probability of an ionising collision as a function of electron velocity. Fig. 6 shows the character of a typical curve. The ionisation starts at a certain minimum

voltage (e.g. 10.4 volts for mercury), which is called the ionising potential, rises slowly to a maximum (at about 100-200 volts), and afterwards falls slowly. Hanle and many other research workers after him have investigated with the same method the emission of spectral lines excited by electrons with nearly uniform velocities. Two typical examples of such excitation curves are also shown in Fig. 6.

We cannot treat in detail the interesting problem of light emission by electric discharges. In discharge lamps this is, of course, the problem of primary interest. Physically, however, light production is only a by-product of the mechanism by which current is transported in gases. Light is emitted only because we cannot ionise a gas without exciting also the lower levels, and excitation is generally followed by radiation. There is,

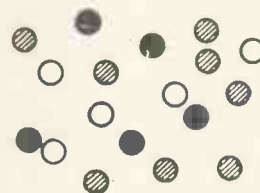

Fig. 7.—Plasma.

however, no simple connection between input and radiation, let alone visible radiation.

There are discharges in which less than one per cent. of the input is radiated, e.g. water vapour, and at the other end of the scale there is the low pressure caesium arc which radiates 96 per cent. of the input in the form of its (infra-red) resonance radiations.

There are two ways of approach in calculating the radiation of a gas discharge. One is to study the collisions statistically and to calculate the emission by means of excitation curves. The difficulty, however, is that the excitation curves of excited atoms are not yet known, and also that in many cases the excited atom will not be left undisturbed until it emits a photon, but suffers another collision.

A better way of approach was opened by the discovery by Ladenburg and Minkowski that the excited states in arc discharges approximately obey a simple law, known as Boltzmann statistics. If the distribution of excited states is known, the radiation can be calculated from

The Plasma

the emission probabilities. Neither of these methods has yet yielded practical results, however, and it is not yet possible to foretell the spectral distribution and light efficiency of a new gas discharge.

The Plasma

After this very short and incomplete survey of the elementary particles and processes, we can now proceed to build up gas discharges with them. One way to do this would be to introduce the particles one by one into a vacuum and see how their interaction results finally in the familiar aspects of the gas discharges. This, however, is a very long method, and the final results would hardly bear any resemblance to our starting point. We will, therefore, adopt another method. We begin by constructing from the elementary particles the "substance" of the gas discharges, or the "plasma" as it was called by Langmuir, from whom this way of approach originates (see Fig. 7).

The plasma is a highly ionised gas, containing equal numbers of positive and negative charges per unit volume, so that as a whole it is electrically neutral, although strong "microscopic" fields exist between the particles. Let us start with the plasma in thermal equilibrium. We could produce such a plasma simply by heating a gas in a furnace to a very high temperature. Actually there is no material to stand the temperatures necessary to produce plasmas approaching the conditions in our gas discharge tubes. Only the most easily ionisable substances such as caesium and rubidium can be heated to temperatures to show appreciable ionisation. There are, however, great plasmas in existence in the stellar bodies; actually, by far the greatest part of all the matter in the universe is in the highly ionised plasma state.

The luminous stars are gaseous balls, held together by their own gravity, with temperatures of millions or even thousands of millions of degrees. It is true that we cannot look into their interior; yet the theoretical physicists claim that they know almost everything about it. For a wonderfully vivid description of the inside of a star plasma, reference should be made to a delightful little book by Sir Arthur

Eddington, entitled "Stars and Atoms" (page 26) from which the following extract is taken:—

"We can now form some kind of picture of the inside of a star—a hurly-burly of atoms, electrons, and etherwaves. Dishevelled

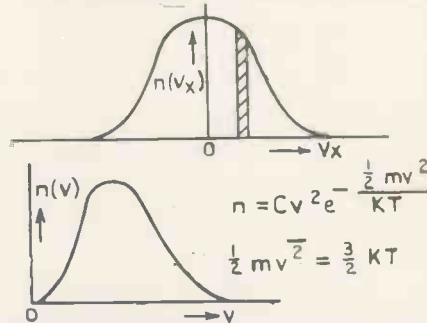

Fig. 8.—Maxwellian distribution of velocities.

atoms tear along at 100 miles a second, their normal array of electrons being torn from them in the scrimmage. The lost electrons are speeding 100 times faster to find new resting places. Let us follow the progress of one of them. There is almost a collision as an electron approaches an atomic nucleus, but putting on speed it sweeps round in a sharp curve. Sometimes there is a side-slip at the curve, but the electron goes on with increased or reduced energy. After a thousand narrow shaves, all

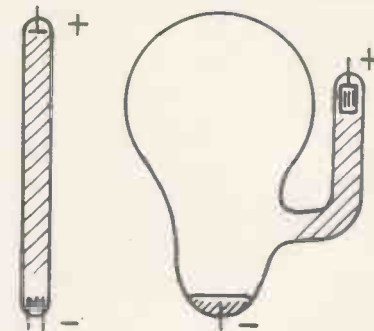

Fig. 9.—Positive column.

happening within a thousand millionth of a second, the hectic career is ended by a worse side slip than usual. The electron is fairly caught, and attached to an atom. But scarcely has it taken up its place when an X-ray bursts into the atom. Sucking up the energy of the ray the electron darts off again on its next adventure." In this terrible disorder the physicist looks for some vestiges of

regularity. If we could look into the plasma, the first thing we should see would be that the light electrons move much faster than the heavier particles, atoms, and ions; and we should find out, as Daniel Bernoulli found out 200 years ago, that all kinds of particles have the same average kinetic energy. On the whole, the distribution of energy will be democratic. A fast particle has far more chance of losing than of gaining energy. On the other hand, whatever the speed of a particle, it can always gain a little more energy from another one, however slow, if the slow particle happens to hit the fast particle sideways; but this is obviously a very improbable process.

We may therefore expect that the velocities will be grouped in some way around an average velocity, so that both very small and very large velocities have small probabilities. The first to discover the shape of this law was James Clerk Maxwell, and Fig. 8 shows the law named after him. The upper figure shows the distribution of velocity components parallel to a given direction, e.g. the x-direction. The shaded area between the two ordinates gives a measure of the number of particles having velocities between these limits. This curve must obviously be symmetrical, as a particle is as likely to go to the left as to the right.

If the particles are grouped according to their *total* velocities, the distribution becomes one-sided, zero being obviously the smallest velocity a particle can have. The mean energy of a particle is $3/2kT$, where T is the absolute temperature, and k is an absolute constant; k must be absolute because we have seen that the mean energy is the same for all kinds of particles at a given temperature. The fact that the particles equalise their kinetic energies is the "microscopic" expression of the "macroscopic" fact that different gases mixed together assume the same temperature.

We see that there is a considerable degree of order in the apparent disorder of the plasma. There is even a kind of regular structure in it. If we could travel with one particular electron, we should see that on the average there is one more ion in its neighbourhood than electrons. This was first discovered by Prof. S. R. Milner for the positive and negative

The Plasma in Gas Discharges

ions in electrolytes, and the consequences for the theory of electrolytes were developed later with great success by P. Debye.

The Plasma in Gas Discharges

Let us now imagine that we enclose a little of the stellar plasma in a gas discharge vessel. It will, of course, be instantaneously cooled by

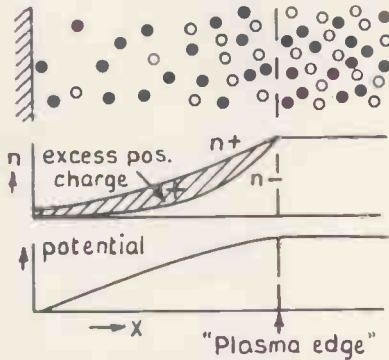

Fig. 10.—Insulated wall in plasma.

the walls, but we can replace the lost energy by directing a gas discharge through it. We obtain a stationary plasma; but it will no longer be in thermal equilibrium. Yet it will retain several of the features of the stellar plasma, especially in the part called the positive column (see Fig. 9). In low pressure gas discharge vessels this is a homogeneously luminous region, extending from the anode to a distance of about 1 to 2 tube diameters from the cathode. In high pressure gas discharge vessels it does not fill the tube but forms a thin, intensely luminous cord in the axis of the tube.

This high pressure arc, as we see it in our high pressure and extra high pressure mercury lamps, is the best terrestrial approach to the stellar plasma. In its centre there is a region which is in almost perfect thermal equilibrium, at a temperature of 7,000 to 10,000 degrees.

In the low pressure column we are very far from thermal equilibrium. The plasma has, however, retained its neutrality, i.e., it contains electrons and positive ions in almost exactly equal numbers. This is true but for a thin sheath at the walls (see Fig. 10). It can easily be seen that the plasma cannot extend to the wall.

In the plasma, the electrons are darting about with far greater velocity than the ions. This means

that if the plasma extended to the wall, far more electrons than ions would reach it. As, however, the wall is insulating, electrons and ions can move to it only in equal numbers. These two currents are equalised by the electrons charging the wall negatively, until all electrons but a few are repelled and the positive ions can arrive at the same rate. In a very thin sheath near the wall there will be an excess of positive ions, just enough to shield the wall charges. Outside this thin condenser the plasma is homogeneous and neutral.

Irving Langmuir was the first to reach these conclusions and to establish the fundamental conception that low pressure gas discharges consist of plasmas, surrounded and protected by thin space charge sheaths at the walls and at the electrodes. He was also the first to recognise the possibility of analysing the plasma by means of the wall currents that can be drawn from it (see Fig. 11).

Let us assume that we make a small area of the wall conducting, so that we can give it different potentials and measure the current that can be drawn from it. Such a conductor immersed in a gas discharge is called a probe, and the relation between its potential and the current

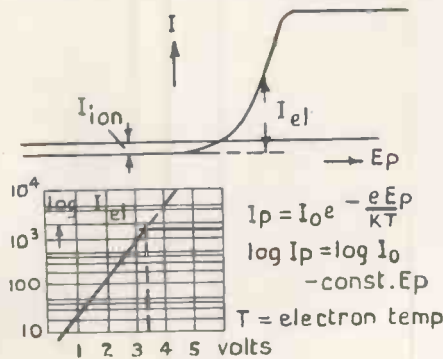

Fig. 11.—Probe characteristic.

flowing through it is called the probe characteristic.

Fig. 11 shows a typical example for a plane probe. At a certain probe voltage the current is zero. We conclude that this is the potential that the probe would assume if it were insulated. If we apply lower voltages to the probe, current will start flowing which soon becomes saturated. We conclude that these must be posi-

tive ions and we must note the curious fact that this current is almost independent of the probe potential.

Let us now see what happens at positive potentials. The current rises rapidly until at a few volts above the wall potential it again reaches saturation. Langmuir con-

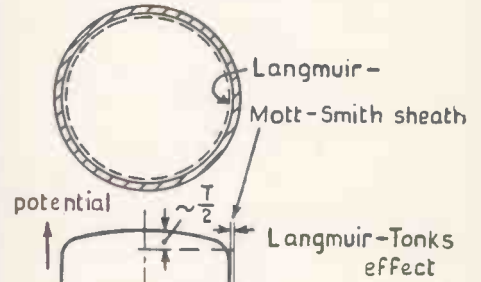

Fig. 12.—Potential distribution in cross-section of positive column.

cluded that this current must be due to electrons that overcome the retarding field in the sheath surrounding the probe. At the saturation point there is no field to overcome, the probe having now the same potential as the plasma, and the probe measures the random current of the electrons, the same as flows through any imagined cross section parallel to the wall. It was found that this random current intensity is at least of the same order as the current that flows along the tube, which may be called the drift current.

The probe characteristic enables us also to analyse the velocity distribution of the electrons. At a certain probe potential all those electrons will reach the wall that have entered the space charge sheath with velocities at least sufficient to overcome the retarding field of the probe. We can therefore immediately conclude how many electrons there are above a certain velocity, and from this determine their distribution law.

Langmuir found that the part of the probe characteristic due to the electron current is almost exactly an exponential function of the probe voltage. This can be seen by plotting the logarithm of the electron current against the voltage; the characteristic is a straight line. From this it follows that the electrons have a Maxwellian distribution of velocities in the plasma. Their distribution is the same as if they formed a gas, with

Movement of Ions and Electrons

a certain very high temperature, called the electron temperature. This is usually of the order of 10,000 to 30,000 degrees in low pressure gas discharges. We can express it also in volts. One volt is equivalent to 7730°K.

The fact, discovered by Langmuir and Mott-Smith, and a little later by Schottky and J. v. Issendorf, that electrons had a well-defined temperature, was very unexpected. It was not surprising that the electrons had such high velocities, corresponding to energies that exceeded many times the mean energy of the gas molecules. It is obvious that elec-

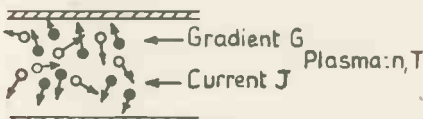

Equations:

1. Ion Balance: For every ion lost on wall a new one made by ionisation.
2. Energy Balance = JG = Losses/cm.
3. Mobility Equation. (Langevin)
Relation between n, G and J

Three equations. Four quantities n, T, J, G . Result: Relation between J and G .

Fig. 13.—Theory of positive column.

trons, by reason of their much higher mobilities, can take much more energy from the electric field than ions, and they have much less chance of losing it. But it was very surprising that they shared it with each other in the same way as when left alone. This suggested some very effective and rapid mechanism of energy interchange between electrons.

The theory, however, failed to account for it. Langmuir pointed out the dilemma in a great number of experiments. He showed that arcs with well-defined electron temperatures could be produced at such low pressure that the electrons had hardly a chance to collide with an atom on their way to the wall; and he showed that their electrostatic interaction was so weak, that it ought to have taken discharge tubes of hundreds of metres in diameter to produce perfect Maxwellian distributions as were actually observed in tubes having diameters of a few centimetres; but no answer was forthcoming from the theoretical physicists, who at that time (1925-1928) were far too busy with the inside of the atom to

pay much attention to problems which they thought settled for ever.

A few years ago the writer advanced a theory which gave surprisingly good agreement with Langmuir's experiments, making use of the Milner-Debye theory of electrolytes and of methods of calculation that were better suited to the long-range forces in the plasma than the older methods of the kinetic theory of gases. The main result of the theory was that the plasma is a strongly diffusing medium for electrons and that even in those experiments of Langmuir, in which the mean free path calculated from the number of molecules was of the order of metres, the mean free path following from the number of charged particles was only of the order of a millimetre.

Although the theory agrees well with the facts found by Langmuir, it would be highly desirable to test it by new experiments. Whether experiments will confirm this theory or not, they will mark some advance in this problem, which is still one of the weak spots of the theory of gas discharges.

In the years following Langmuir's discovery, electron temperatures were accepted as experimental facts, and they are the basis of all modern theories of the positive column, the most comprehensive of which has been developed by Tonks and Langmuir.

There was one particular point, mentioned above, which demanded clarification. The probe experiments showed that positive ions arrived at the plasma edge with velocities corresponding to about half the electron temperature. The existence of a high ion temperature, analogous to the electron temperature, could be dismissed on theoretical grounds. No mechanism could be imagined that could impart to the ions such high random velocities.

Langmuir and Tonks proved in a very thorough theoretical study that the velocities of the ions at the plasma edge were ordered rather than random. They showed that adjoining the edge of the Langmuir-Mott-Smith sheath, there is another sheath from which the wall collects ions, the thickness of which is several times that of the former and might extend well towards the middle of the tube (see Fig. 12). In this sheath there is a poten-

tial drop, driving the ions towards the wall, and this drop is, at very low pressures, of the order of the electron temperature.

We can now draw a fairly complete picture of the positive column, recapitulating and completing the previous results (see Fig. 13). The plasma of the positive column is a mixture of three gases, the neutral gas, the ion gas, and the electron gas. On closer scrutiny the neutral gas appears as a mixture of several gases, atoms in different excited states, of which the metastables are the most important. The temperature of the neutral gas in low pressure gas discharges is generally low; it

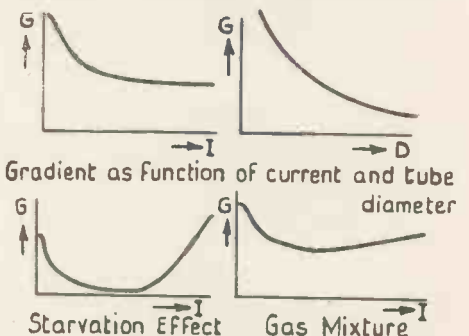

Fig. 14.—The gradient.

is even possible to produce arcs at the temperature of liquid air.

The second gas, the ion gas, has a temperature that is higher than the gas temperature only by a negligible amount. Superimposed on the random movement corresponding to this temperature there is an ordered movement, which is mostly radial, directed towards the walls. There is also an ion drift in the direction of the tube axis; but this carries only a small proportion of the current (approximately $\sqrt{m/M}$.) the rest of the current being transported by the electron gas. The latter has a random movement corresponding to a very high temperature. This electron temperature is generally higher, the higher the ionisation potential of the gas and the lower the gas density. This random movement of the electrons is mainly responsible for the whole ionisation in the arc, and also for the light emission as a by-product.

Superimposed on this random movement, there is a drift movement along the axis, carrying almost the whole current. This drift movement

(Continued on page 668)

A RECORD OF PATENTS AND PROGRESS

RECENT DEVELOPMENTS

"Daylight" Television Screen
(Patent No. 507,381.)

It is usual to deposit the fluorescent material forming the screen of a cathode-ray tube on a very thin metallic coating which has previously been laid over the glass of the tube. In the ordinary way, this coating tends to reflect back into the eyes of an observer any daylight or artificial

of a cathode-ray tube is used for line scanning only, the "framing" movement being supplied mechanically by an external rotating drum. Each scanning line is, however, repeated three times, once for each of the primary colours, the usual "vertical" deflecting-peaks of the cathode-ray tube being used for this purpose.

As shown in the figure, the elec-

PATENTEES

N. V. Philips Gloeilampenfabrieken :: **E. C. Cork**
and J. I. Pawsey :: **Kolster Brandes Ltd.** :: **Radio-**
Akt. D. S. Loewe :: **Scophony Limited and A. H.**
Rosenthal :: **O. Klemperer and F. H. Nicoll**

changes, thus reducing wear and tear on the screen and prolonging the life of the tube.

The screen is made of larger area than usual, and rotates about the major axis of the tube whilst the electron stream scans an area which is eccentric to that axis. The outer margin of the screen is formed with wings or ridges, similar to those used on the rotor of a turbine, and the electron stream is periodically deflected, say, by the synchronising impulse, so as to rotate the screen from time to time by turbine action.

The invention can be applied to the photo-electric "mosaic" screens used for transmission, or to the sensitive secondary-emission screens used for intensifying the strength of the electron stream, or in any other case where the life of the tube is determined by that of the screen.—*Scophony, Ltd., and A. H. Rosenthal.*

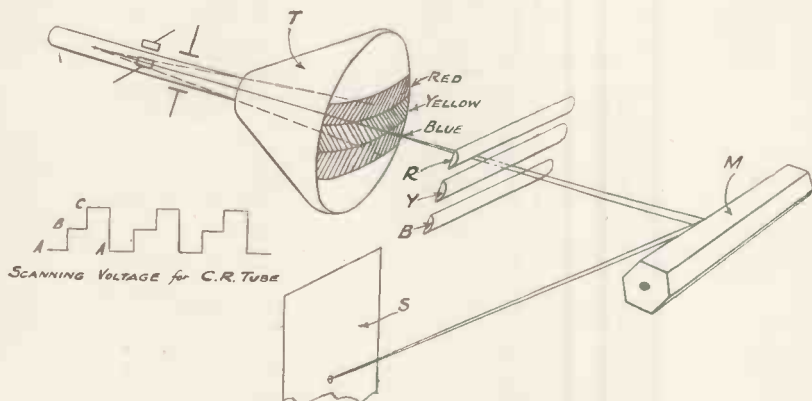

Scheme for Colour Television. Patent No. 508,037

illumination there may be in the room, which, by "diluting" the fluorescent glow, robs the picture of its natural contrasts, and makes it difficult to see unless the room is darkened. In addition, light so reflected back produces a "halo" effect which tends to obscure the details.

According to the invention, the glass wall of the tube is first "satin-frosted," before any metallic coating is applied; the metal rhodium is preferably used as the coating. Although the frosting necessarily leads to a certain loss in the fluorescent light, it substantially prevents any back reflection of light from the room, and so allows the picture to be seen more clearly in daylight, or when the room is artificially illuminated. It also prevents any undesirable halo.—*N. V. Philips Gloeilampenfabrieken.*

Television in Colours

(Patent No. 508,037.)

In order to reproduce pictures in natural colours, the electron stream

tron stream through the cathode-ray tube T is controlled by a three-stepped scanning voltage (of the shape shown in the separate diagram) so that each scanning line is repeated three times, passing in succession through the red, yellow, and blue bands of the fluorescent screen. The three lines are focused by cylindrical lenses R, Y, B on to a rotating mirror-drum M, which supplies the "framing" movement to the coloured spot of light finally thrown on to the viewing-screen S. The coloured fluorescent bands can be replaced by red, yellow, and blue colour filters.—*Kolster Brandes, Ltd. Application date 24th December, 1937.*

Saving the Screen

(Patent No. 508,712.)

The fluorescent screen of a cathode-ray tube, particularly of the so-called "projection" type, is arranged to be continuously rotated, preferably by the automatic action of the electron stream, so that the latter impacts on a surface which constantly

Television Aerials

(Patent No. 509,500.)

A quarter-wave conductor makes a very efficient aerial, but when it is located at a considerable height above ground, as in the case, say, of a television transmitter, difficulties arise in preventing energy losses along the outer sheath of the concentric feed-line.

According to the invention these losses are minimised by "earthing" the feeder through one or more capacity wires, which are less than a quarter-wave long and are series-tuned to the operating wavelength, so that, in effect, they present a low impedance "to space" at the point at which they are connected. In other words the feeder is effectively "earthed" at that point.

The "earth" may take the form of a wheel which is mounted about the feeder as hub. It is made with telescopic spokes and an overlapping rim, so that it can be adjusted to different wavelengths.—*E. C. Cork and J. L. Pawsey.*

Interlaced Scanning

(Patent No. 509,831.)

Any slight inaccuracy in the cor-

rect spacing of the two frames used in interlaced scanning at once becomes noticeable in the received picture. In most cases it is due to the fact that slight traces of the line-synchronisation voltages are still

stream, thus producing a clear-cut scanning spot.

As shown in the drawing, the electron stream is emitted from a concave cathode C which is suspended in the centre of a tubular metal electrode T

(Patent No. 507,428.)

Preventing "keystone" distortion, particularly in interlaced scanning.—*The General Electric Co., Ltd., and D. C. Espley.*

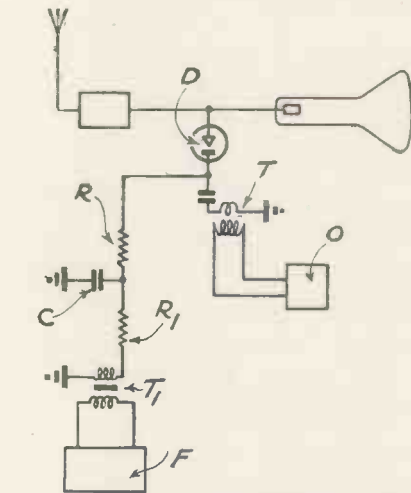

Delay circuit for accurate interlacing. Patent No. 509,831.

present at the moment when the next frame impulse begins, and so make their way through that channel. Usually, the frame-change impulse occurs alternately at the end and middle of a line impulse, so that the residual voltages in question have an unequal effect in the two cases.

To avoid this source of trouble, the transmission of the line-synchronising impulses is deliberately interrupted during the transmission of the framing-impulse, and a delay circuit is inserted to retard the effect of the framing-impulse until the remnants of the line impulses have died away.

As shown in the drawing, the picture and synchronising signals are separated by a rectifier D. The line impulses pass direct to the oscillator O through a transformer T, whilst the frame impulses are fed via a retardation network R, R1, C before reaching the transformer T1 and the oscillator F.—*Radio-Akt. D. S. Loewe.*

Cathode-ray Tubes

(Patent No. 510,699.)

The effective length of a cathode-ray tube is reduced by adding what is the equivalent of a "mirror" to the electron-focusing system of the tube. The arrangement has the further advantage of correcting any spherical aberration in the focused

Electron mirror in cathode-ray tube. Patent No. 510,699.

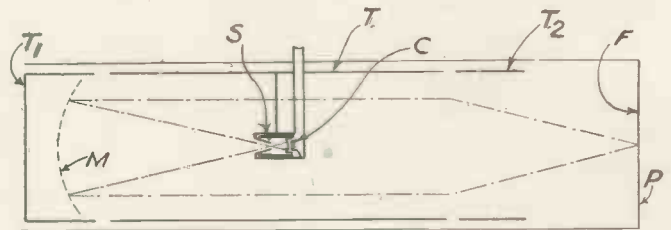

carrying a positive charge of 2,000 volts. At the lower end of the C.R. tube another electrode T1 carries a negative charge of 1,000 volts. The electron stream is modulated in the usual way by a screen electrode S and is projected towards the negative electrode T1. When it reaches the equipotential region M separating the positive and negative fields, it is reflected back, as from a mirror following the path shown in dotted lines. A third electrode T2, carrying a positive bias of 20,000 volts, then deflects the stream and brings it to a sharp focus at the point P of the fluorescent screen F.—*O. Klemperer and F. H. Nicoll.*

(Patent No. 507,582.)

Television cabinet in which the received picture is projected on to a vertical viewing-screen.—*Fernseh Akt.*

(Patent No. 508,039.)

Cathode-ray television receiver in which interlaced scanning is used to reproduce pictures in natural colour.—*Baird Television, Ltd., and J. L. Baird.*

(Patent No. 508,065.)

Light-modulating device utilising supersonic "compression waves" of different frequencies.—*Scophony, Ltd., J. Sieger and F. Okolicsanyi.*

(Patent No. 508,076.)

Scanning system in which the intensity of a ray of light is controlled by "spokes" which rotate at a speed controlled by the incoming signals.—*J. Leonard.*

(Patent No. 508,391.)

Construction of the mosaic-cell screen used in the Iconoscope type of television transmitter.—*Marconi's Wireless Telegraph Co., Ltd.*

(Patent No. 509,715.)

Supersonic light-cell in which compression waves are produced by the action of a cathode-ray stream on a piezo-electric crystal.—*Scophony, Ltd., and F. Okolicsanyi.*

(Patent No. 509,766.)

Supersonic light-cell for a television receiver in which means are provided for immobilising the compression waves, relatively to the C.R. screen, in order to produce a brighter picture.—*Scophony, Ltd., and A. H. Rosenthal.*

Summary of Other Television Patents

(Patent No. 505,167.)

Television transmitter designed to increase the effective contrast between the light and dark elements of the picture.—*Radio-Akt. D. S. Loewe.*

(Patent No. 505,252.)

"Blocking" oscillator circuit for generating saw-toothed scanning voltages.—*W. S. Percival.*

(Patent No. 505,355.)

Preventing de-focusing of the scanning-spot in a cathode-ray tube particularly at the limits of its deflection.—*Radio-Akt. D. S. Loewe.*

Please ask your bookstall or newsagent to reserve a copy of **ELECTRONICS AND TELEVISION & Short-Wave World** each month and avoid disappointment. Mention of "Electronics and Television & Short-wave World" when corresponding with advertisers will ensure prompt attention.

THE SHORT-WAVE RADIO WORLD

A Compact Amplifier

The introduction of a new type of tuning condenser by Hammarlund with an insulated rotor enables a compact r.f. amplifier to be built measuring only $11\frac{1}{2}$ in. by 8 in. by $5\frac{1}{2}$ in. The amplifier will deliver 175 watts using two HK24 valves. The rotor of the anode tuning condenser is connected to the H.T. lead to avoid applying H.T. to the fixed plates, and this connection allows a smaller

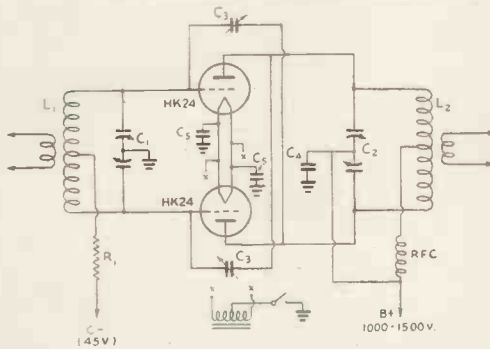

Fig. 1. Circuit diagram of the HK 24 amplifier.
 C₁, C₂—100- μ fd. per section, 0.05-in. spacing (Hammarlund HFB-100-C).
 C₃—Disc-type neutralizing condenser (Hammarlund N-10).
 C₄—500- μ fd. mica, 5,000-volt.
 C₅—0.01- μ fd. paper, 1,000-volt.
 RFC—2.5-mh. r.f. choke (125-m/a. size satisfactory).
 R₁—3,000 ohms, 10-watt.

condenser construction to be employed. The rotor is insulated from earth by isolantite end plates, and voltages up to 1,000 can be used with anode modulation.

The amplifier is suitable for operation on 80, 40, 20 and 10 metres, and since the series minimum capacity is 9 mmfds. there is no difficulty in obtaining resonance throughout the 10-metre band.

G. W. Shuart, QST, Oct., 1939.

A New Taylor Transmitter

The Taylor TW-150 is the first transmitting valve to use the new thin-wall carbon anode. This anode is cup-like in shape and is turned out from a solid block of carbon to a thickness of 0.015 in. The light weight of the anode makes a relatively high-capacity supporting structure unnecessary and, volume being reduced, there is less danger of occluded gas. The tube is a high-power triode.

The tentative ratings of the TW-150 follow:—

A Review of the Most Important Features of the World's Short-wave Developments

Maximum anode voltage	3,000
Maximum anode current	200 ma.
Maximum rectified grid current	60 ma.
Anode dissipation	150 w.
Amplification factor	35
TYPICAL OPERATION—CLASS C TELEGRAPHY	
Anode volts (d.c.) .. 2,000	2,500 3,000
Anode current (d.c.) .. 200 ma.	200 ma. 200 ma.
Grid current (d.c.) .. 46 ma.	45 ma. 45 ma.
Grid bias volts (d.c.)* .. -92	-120 -173
Grid volts (peak a.c.) .. 322	350 411
Anode dissipation (watts) .. 112	127 135
Power output (watts) .. 288	373 465
Anode efficiency (%) .. 72	74.5 77.5
Anode angle (degrees) .. 165	160 150
Driving power (watts) .. 13.35	14.25 16.75
CLASS C TELEPHONY	
Anode volts (d.c.) .. 2,000	2,500 3,000
Anode current (ma. d.c.) .. 200	185 165
Grid current (ma. d.c.) .. 46	43 40
Grid bias (volts d.c.)* .. -142	-195 -257
Grid volts (a.c. peak) .. 379	430 487
Anode dissipation (watts) .. 103	101 95
Power output .. 297	361 400
Anode efficiency (%) .. 74.25	78 80.75
Anode angle (degrees) .. 150	140 130
Grid driving power (watts) .. 15.7	16.9 17.3
Anode volts .. 2,000	2,500 3,000
Battery bias (volts) .. 60	75 90
Grid leak (ohms) .. 1,775	2,740 4,225

CLASS C TELEPHONY	
Anode volts (d.c.) .. 2,000	2,500 3,000
Anode current (ma. d.c.) .. 200	185 165
Grid current (ma. d.c.) .. 46	43 40
Grid bias (volts d.c.)* .. -142	-195 -257
Grid volts (a.c. peak) .. 379	430 487
Anode dissipation (watts) .. 103	101 95
Power output .. 297	361 400
Anode efficiency (%) .. 74.25	78 80.75
Anode angle (degrees) .. 150	140 130
Grid driving power (watts) .. 15.7	16.9 17.3
Anode volts .. 2,000	2,500 3,000
Battery bias (volts) .. 60	75 90
Grid leak (ohms) .. 1,775	2,740 4,225

A Precision Frequency Monitor

Browning Laboratories, Inc., of Boston, Mass., have designed and produced a new frequency monitor incorporating band-spread on all bands, giving readings to 5 kc.

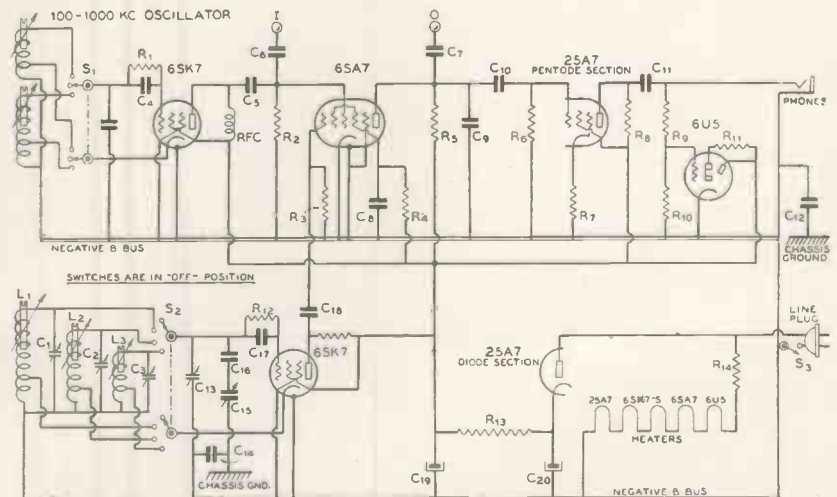

Fig. 2. Wiring Diagram of the Frequency meter-monitor.

- | | | | |
|--|---|---|---|
| C ₁ , C ₂ , C ₃ —Trimming condensers across the h.f. oscillators. | C ₁₂ —0.1- μ fd. 600-volt tubular. | R ₄ , R ₅ —50,000 ohms, $\frac{1}{2}$ watt. | R ₁₄ —220-ohm line cord resistor. |
| C ₄ —0.001- μ fd. mica. | C ₁₃ —3- μ fd. trimmer condenser. | R ₆ —1.0 megohm, $\frac{1}{2}$ watt. | L ₁ , L ₂ , L ₃ —Permeability-tuned inductances for the three oscillator ranges. |
| C ₅ —0.001- μ fd. mica. | C ₁₄ —0.02- μ fd. mica. | R ₇ —1,000 ohms, 1 watt. | S ₁ —100 - 1,000 kc. oscillator switch. |
| C ₆ —0.0001- μ fd. coupling condenser. | C ₁₅ —Main tuning condenser. | R ₈ —5,000 ohms, 1 watt. | S ₂ —High - frequency range switch. |
| C ₇ —0.00025- μ fd. coupling condenser. | C ₁₆ —44.5- μ fd. tracking condenser. | R ₉ —100,000 ohms, $\frac{1}{2}$ watt. | S ₃ —A.C. line on-off switch. |
| C ₈ —0.1- μ fd. 400-volt tubular. | C ₁₇ , C ₁₈ —0.001- μ fd. mica. | R ₁₀ —1.0 megohm, 1 watt. | |
| C ₉ —0.01- μ fd. 400-volt tubular. | C ₁₉ , C ₂₀ —Dual 16- μ fd. 200-volt elect. | R ₁₁ —250,000 ohms, $\frac{1}{2}$ watt. | |
| C ₁₀ , C ₁₁ —0.1- μ fd. 400-volt tubular. | R ₁ —1.0 megohm, $\frac{1}{2}$ watt. | R ₁₂ —1.0 megohm, $\frac{1}{2}$ watt. | |
| | R ₂ , R ₃ —100,000 ohms, $\frac{1}{2}$ watt. | R ₁₃ —2,000 ohms, 10 watt. | |

The circuit is shown in the diagram of Fig. 2, while Fig. 3 shows the layout adopted. The fundamental operation of the circuit shown in Fig. 2 is best understood by reference to the block diagram, Fig. 3. A 100-1,000 kc. oscillator is used as a secondary standard. A second series of three oscillators chosen at will by means of a band switch are so designed that their fundamentals or harmonics are continuously variable over the amateur bands, bandspreading each. A mixer valve is employed so that the signal from the 100 or 1,000 kc. oscillator and the variable oscillators may beat with the other without any "locking in" effects. The two oscillators mixing thus give numerous zero beat points throughout the range of the variable oscillator making it possible to check its frequency accurately.

The signal from the 100-1,000 kc. oscillator is fed through the mixer valve and the output taken from the mixer anode to a radio receiver which has been tuned to 5.0 Mc. The 100 and 1,000 kc. oscillators are each adjusted to zero beat. As the "take off" for this oscillator is from the anode of the mixer it can in no way

Series Valve Noise Limiter

affect the frequency of the 100-1,000 kc. oscillator. These oscillators may be adjusted to zero beat to within at least 25 cycles in 5,000,000 cycles and will remain to this precision with the "output" lead disconnected. During this process, the variable oscillator is "off."

After setting this secondary standard accurately, the variable oscillators are turned "on" and the band switch thrown to the desired amateur band. The 100-1,000 kc. oscillator is switched to the 100-kc position and the dial calibration checked at numerous points by zero beating the harmonics of the 100-kc. oscillator with fundamentals and har-

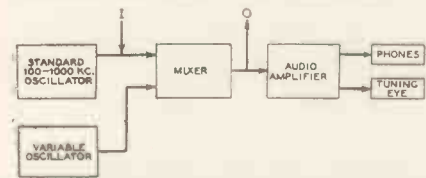

Fig. 3. Block diagram showing the electrical hookup of the various units of the frequency meter-monitor.

monics of the variable oscillator. For instance, in the 160-metre band there will be zero beat check points at 1.75, 1.80, 1.85, 1.90, and 2.0 Mc. In the 20-metre band, zero beat check points at 14.0, 14.1, 14.2, 14.3 and 14.4 MC. By utilizing a 6U5 electric eye as well as phones for a zero beat indicator, the variable oscillator may be adjusted to within 15 cycles or better to the harmonics of the 100-kc oscillator. An extremely high degree of accuracy may thus be obtained since the dial calibration between any two check points holds as close or closer than can be read.

A small 3-mmfd. trimmer placed across the tuned circuits of the variable oscillator may be used to set the variable oscillator on frequency at any one of a number of points which may be marked for reference on the dial.

Two 6SK7 valves are used for the oscillators, these having been found to afford a maximum of stability. The anode voltage for the valves should be about 80 volts, a value far below that for which they are rated. In this way stability is further improved. In placing the wiring between the various components, it is essential to keep all leads which could in any way affect frequency very rigid. For this reason, bus-bar

should be used for all these leads. The circuit components must also be rigidly mounted. The H.T. supply may be obtained by means of a half-wave rectifier, operation being possible from either A.C. or D.C. This type of power supply is preferable from the standpoint of voltage regulation, as one element which affects regulation, the power transformer, is eliminated. However, the circuit shown is not materially affected by line voltage as changes of 30 volts result in a frequency change of the standard of only about 100 cycles and in the variable oscillator of about 200 cycles.

A "Series Valve" Noise Limiting Circuit

In last month's issue we described a noise limiting circuit used by Murphy Radio in their television receivers. This circuit, by D. H. Bacon in the October QST, gives an alternative method of noise limitation.

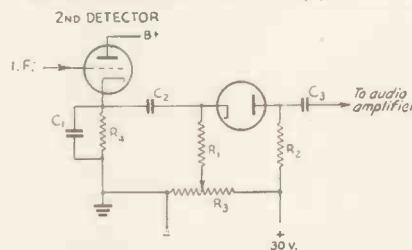

Fig. 4. The series limiter circuit, with infinite-impedance detector.

R_1 —0.25 megohm. C_1 —250 μ fd.
 R_2 —50,000 ohms. C_2, C_3 —0.1 μ fd.
 R_3 —10,000-ohm potentiometer.
 R_4, R_5 —20,000 to 50,000 ohms.

Ever since early 1936, when James Lamb presented the first of a series of articles dealing with noise silencers as applied to amateur communications receivers, innumerable new silencer or limiter circuits have appeared in the various popular radio magazines. The majority of the schemes presented had little merit for, although they appeared to be good theoretically, they failed to work because one or more of four fundamental considerations were overlooked.

Please ask your bookstall or newsagent to reserve a copy of **ELECTRONICS AND TELEVISION & Short-wave World** each month and avoid disappointment.

1. A good noise silencer must be practically instantaneous in its action.
2. It must have a very definite, adjustable level at which the silencing, or limiting, action starts.
3. The limiting action must be complete after the threshold level has been reached.
4. The silencer should not have any effect upon the signal being received.

Analysis of the silencers used heretofore will show that in many cases they do not fulfil all of the above requirements. For instance, an A.V.C. type of silencer may be too slow in its action and a strong noise pulse will "chop a hole" of appreciable duration in the carrier, in violation of 4 above, producing a similar effect on the loudspeaker as the original noise pulse.

The circuit shown by Fig. 4 was devised after an investigation of the more meritorious silencer arrangements. It is very simple and it has been found to be extremely effective. The action is as follows. An adjustable voltage from the potentiometer R_3 is connected to the diode elements through resistors R_1 and R_2 , the polarity being such that a current is maintained between the diode anode and cathode. The diode elements are, therefore, in a conducting condition and will allow audio voltages to pass backwards from cathode to anode, and the circuit between input and output will be complete as long as the diode anode remains positive with respect to the cathode. If, however, a noise peak of sufficient amplitude is impressed upon the input circuit the diode immediately becomes non-conducting and prevents the noise pulse from reaching the audio amplifier.

It can easily be seen that this arrangement fulfils the four fundamental characteristics outlined above, since it is instantaneous in action, has a sharp adjustable level where silencing action begins, limiting action is complete, and the signal itself is unaffected.

The fundamental difference between this limiter and others employing diodes is that the diode elements are connected in series, passing the desired signal and eliminating noise peaks, whereas the shunt-connected diode is intended to pass noise peaks

Infinite Impedance Detector

without passing the signal. There is, of course, some audio attenuation in the series limiter, but this is easily taken care of by increasing I.F. and audio gain.

It must also be realized that a limiter, no matter how perfect, cannot remove that portion of the noise

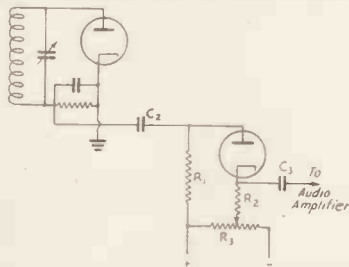

Fig. 5. Series limiter as used with detectors such as the ordinary diode, delivering "negative" audio signals. Components have equivalent values given in Fig. 1. The diode load circuit constants are conventional.

which has the same amplitude as the signal without introducing serious distortion. In the case of 'phone reception, the limiter will be adjusted so that all desired audio peaks will just pass under the threshold; when receiving C.W. signals, however, the limiter threshold can be lowered considerably, further reducing noise peaks. Such an adjustment will, of course, cut down the audio volume of the C.W. signal slightly and will change its quality, but both changes are small as compared to the gain in noise reduction.

There are a few more points which should be considered. The first thing to consider is the type of second detector which the receiver employs. The so-called infinite impedance diode appears to be most satisfactory for use with the series limiter, since it delivers the positive side of the signal envelope to the limiter diode, and will supply ample voltage without danger of overload. The values shown in Fig. 4, have been found satisfactory.

Most of the common diode detectors, wherein the audio voltage is developed across a high resistance in the anode return circuit, eliminate the negative half of the signal envelope but the remaining positive half builds up negative voltages, with respect to earth across the load resistor. These negative voltages will not actuate the series limiter in the manner previously described unless the circuit is rearranged. This can be very easily accomplished by following

the circuit of Fig. 5 which shows the diode elements interchanged. In this case, the limiter will pass negative voltages up to the point where the anode is negative with respect to the cathode, i.e., up to the threshold, after which the diode becomes an insulator, as previously explained.

The arrangement shown in Fig. 4 is not self-adjusting, since it was developed primarily for use with receivers having flat A.V.C. systems which automatically maintain the detector output level at the proper value. In any case, it is usually advantageous to be able to adjust the limiter control to provide best noise suppression for the particular operating conditions which exist, at any given time.

It is important that the second detector be able to supply an audio signal of about ten volts to the limiter circuit. A signal of this magnitude makes possible a good range of control with a sharply defined limiting threshold and avoids the necessity for using a high-gain audio amplifier. Such considerations are, of course, in agreement with the best accepted design practice in communications receivers.

The reader who is familiar with the problems encountered when working with limiter circuits has probably wondered about the blocking effect of strong, steady, noise pulses when they are impressed upon the A.V.C. system. This is, of course, a drawback to a limiter which is connected in the audio circuits, rather than in the I.F. amplifier, but it has been found possible to overcome A.V.C. blocking to a considerable extent by using a separate A.V.C. valve coupled to the I.F. line with a condenser-and-resistor combination, which renders the circuit insensitive to voltage impulses of high amplitude. This feature, together with correct adjustment of the time constant of the A.V.C. system as a whole, has been found to constitute a satisfactory solution.

One other point: The C.W. oscillator should not deliver to the second detector any more voltage than is necessary to provide a satisfactory C.W. beatnote. If the oscillator voltage at the detector is too great, it will provide a carrier of considerable amplitude for the noise pulses to modulate and, obviously, under such conditions the limiter will have con-

siderably more work to do. As previously stated, however, this difficulty is avoided when the proper amount of C.W. oscillator voltage is employed.

Although the installation of the series limiter itself in a receiver is very simple, it should be evident that the work must be done with care and that results will be satisfactory only if the several factors mentioned are taken into consideration.

The "Infinite Impedance" Detector

Although the infinite impedance detector is at least several years old, it is just recently that it has been incorporated in some of the new receivers, giving rise to speculation as to its possible advantages. In its simplest form, as shown in Fig. 6-B, the load resistor R_1 is by-passed for the intermediate frequency by C_1 and the plate is by-passed for audio frequencies by C_3 . The rectified audio component is coupled to the audio amplifier through C_2 . The input impedance is nearly a pure capacitive reactance which becomes part of the tuned circuit without loading it, and thus the gain and selectivity are not impaired. The modulation capa-

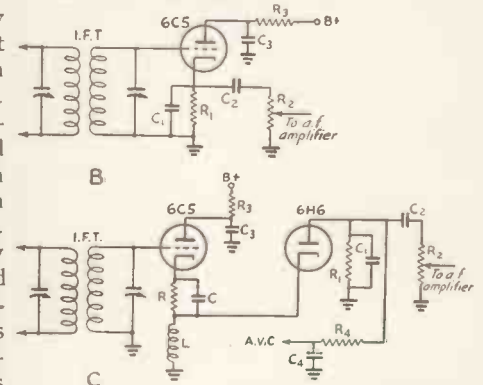

Figs. 6, B and C. Two infinite impedance detector circuits.

bility is excellent, reaching 100 per cent. with normal values of resistors. Typical values would be $R_1 = 150,000$ and $R_2 = 250,000$ ohms. Any trouble with R.F. getting on the grid of the audio amplifier can be eliminated by making R_1 a 50,000- and 100,000-ohm resistor in series, with the lead to C_2 connected at the junction so that the audio load is tapped one-third down on the load resistor.

(Continued on page 653).

News Brevities—

Commercial and Technical

READERS who have special technical qualifications should submit their names and qualifications to the Central Register of Specialists, organised by the Ministry of Labour. The object of the Register is to prepare a complete file of every specialist in the country. It is officially stated that:—

No person should be debarred from offering his services because he is already under an obligation for other forms of National Service, or is engaged in work of national importance.

The selection of persons from the Central Register will not be made without the permission of the person's employer. The volunteer will be the judge of the suitability of the post offered. Persons included in the Schedule of Reserved Occupations and in the Central Register should not accept service otherwise than in their professional or trade capacity.

* * *

The Air Ministry asks us to state that civilians with high technical qualifications may still apply for commissions to serve as Signals Officers in the Royal Air Force. Applications, marked "For the attention of Signals 1(A)," should be sent to the Under Secretary of State, Air Ministry.

* * *

The use of sub-audible modulation has several possibilities of usefulness, all requiring study. For example, it could be used for volume range expansion with control furnished by the transmitter control room engineer in accordance with the musical or technical needs of the programme. There is one special use of sub-audible modulation which seems to be not only worth while at present, but even necessary in the near future. It is the turning on and off of receivers by signals from the transmitter, accomplished by a special control signal having either audible or sub-audible modulation. Furthermore, in ordinary sound broadcasting, it would be highly useful if receivers could be turned on by transmitters, in the event of important news flashes, for example. Especially in times of national emergency or international crises, such a device would be appreciated.

A recent French invention by M.

Jean Dupart (840,423) describes a new form of television camera in which the mosaic is composed of numerous piezo-electric crystals insulated from each other and packed with their longitudinal axes in the direction of the scene to be scanned. The surface of the crystal block is ground flat in the direction of the scene but at the other end the surface is oblique to the crystal axes. Each crystal is thus of a different length and has a different resonant frequency. The block forms in effect a multiple oscillator which when connected to a suitable circuit will resonate throughout the frequency range determined by the dimensions of the crystals.

The amplitude of the oscillations is determined by the light falling on the ends of the crystals. When used as a transmitter, the ends of the crystals are coated with photo-electric emitter and a cathode-ray is used as a flexible conductor. The photo-electric emission affects the oscillatory current in the crystal to a degree depending on the illumination of each crystal element.

A similar crystal block, with slight modification, it is claimed, can be used for reception. A fine gauze is mounted a short distance from the face of the block and the whole is enclosed in a rare gas atmosphere. The H.F. potentials received from the transmitter are applied between the gauze and the rear ends of the crystals on which a conducting coating has been deposited. As each crystal resonates, its extremity becomes luminous and shows through the gauze. It is also possible to use a fluorescent material as a coating on the ends of the crystals.

* * *

The opinion was expressed by Mr. T. E. Thomas, general manager (operations) of the London Passenger Transport Board, in his presidential address to the Institute of Transport in London, that manufacturers of car accessories have a wide field in the provision of a televised means of advising drivers what is out of sight due to fog, or the interposition of opaque objects.

A crystal-controlled oscillator which will accurately serve many of the purposes of frequency meters and

service oscillators is the new Hallcrafters HT-7 Frequency Standard.

Fundamental outputs at 1,000, 100 and 10 kc. are provided, each with harmonics made useful even in the highest frequency ranges by a built-in, tunable harmonic amplifier stage. A dual-type 1,000-100 kc. crystal controls the outputs at these frequencies. The 100-kc. crystal position also locks in a multivibrator which provides the 10- kc. output. Precise accuracy of the 100-kc. output (and therefore the multivibrator 10-kc. output) is assured by provision for slightly varying its frequency to resonate exactly, at its fundamental or a harmonic, with other standards. Exactness to a fraction of one cycle is thus obtainable. The 10-kc. harmonics are strong enough to provide useful check points to well over 15 megacycles and the 100 and 1,000 kc. harmonics well beyond 30 mc.

Four valves serve as crystal oscillator, multivibrator, harmonic amplifier and power-supply rectifier.

* * *

The use of flexible glass braid for wire insulation is an American innovation. The new wire is recommended for installations where operation is at continuous high temperatures and where the wire may be subject to frequent bending. The glass braid does not get brittle, char, or crack but retains its flexibility because it is unaffected by heat.

* * *

Glass insulation is made from glass fibres of exceedingly small cross section. Yarn formed from the fibres is quite flexible and may be woven into tape, cloth and sleeving or it may be used to cover wire in place of cotton or silk covering. For a given current to be carried, the wire may be smaller in cross section if glass insulation is used as a considerable temperature rise is of no importance; a saving of weight up to 30 per cent. is possible in some cases.

* * *

A new method recently developed in France, it is claimed, permits an entire programme of five hours' duration to be recorded on a single normal size gramophone record. The procedure employed is not the usual one of mechanically cutting a wax master disc but is analogous to that used by the film industry wherein the sound is changed to a series of light pulses and recorded photographically on a film. In this case, however, instead of a continuous film, the light

variations are focused and recorded in a spiral path on a large sensitised disc. When the complete programme has been recorded, the disc is developed and a photographically reduced copy made to obtain a new disc of normal size.

Reproduction is accomplished by exploring the disc with a constant intensity light beam which reflects from the surface through a system of lenses into a photo-electric cell. The amount of light reaching the cell is dependent upon whether the particular spot being scanned is light or dark. The cell changes the varying pulses back into electrical energy. This is amplified to the proper level and in turn is changed back into the original sound.

* * *

A stage show of a man who can leave his shadow behind has been creating a good deal of interest in America. The performer sits down in front of a curtain, gets up while his shadow remains sitting, then shakes hands with it and then goes off leaving his shadow behind.

The explanation is that the screen on which the shadow is cast is made of a phosphorescent material. The screen stores up the light which it receives from a powerful spotlight and continues to glow after the light has been turned off. And so, when the performer stands or sits in front of the screen, all of it is "charged" with light except the part obscured and all of the screen glows except the part which received no light. Given a strong enough light, the screen will continue to glow for as long as 10 minutes.

* * *

Equipment which has had the effect of doubling the carrier power of short-wave stations WGEA and WGEO, as well as resulting in a more faithful reproduction of programmes, is now in operation. The increased carrier power effect is brought about by the use of peak limiting amplifiers, which allow the two stations to transmit at a higher power level.

New line equalisers between the studios and the transmitter have also resulted in the extension of the upper limit of the audio range from 5,000 to 8,000 cycles.

* * *

That television entertainment is entirely feasible on board small yachts or other craft, was recently demonstrated for a television party

held on a 35 ft. sailing boat, while off Huntington, in Long Island Sound.

A baseball game was picked up via W2XBS on the Empire State Tower. The pictures were excellent, and the party followed the game with all the thrills and excitement of the distant crowd. There was some picture fading at times, with the changing of the boat's position. Best results were attained with dipole at certain angles to transmitter, which was 35 miles away. The dipole was only 20 ft. above the water line. The excellent reception with reports from television set-owners along the shore of Long Island, Connecticut and New Jersey, strengthens the idea that television signals can cover greater distances over water.

* * *

Taylor Electrical Instruments, Ltd., have recently taken spacious new factory accommodation at Slough for the express purpose of manufacturing a large and comprehensive range of precision moving coil meters. The company intend to continue to produce their full range of instruments without any deletions, and most models are available from stock. As production was planned before hostilities commenced there will be no immediate increase of prices.

* * *

The following list of short-wave stations which are easily receivable in this country together with the times of the news bulletins has been compiled by Mr. F. G. S. Wise, of Stourbridge, who has made a careful study of the times when the different international news bulletins can be picked up.

Station	Time B.S.T. (p.m.)	Wavelength Metres
Rome	7.18	31
B.B.C. Empire Programme ..	8.00	49
Berlin	8.15	31
B.B.C. Home Service	9.00	450
Moscow	9.10	31
Hamburg	33 ²
Paris	9.30	1650
New York N.B.C. ...	9.55	19
Berlin	10.15	31
Rome	10.15	31
Moscow	10.20	1744
Moscow	10.20	31
Athlone	10.30	530
Tokio	10.30	19.25 & 48
New York	10.50	16
Budapest	10.50	549
China	11.00	25
New York	11.30 or 11.45	25
B.B.C. Home Service	12.00	450

Several factors due to war-time conditions such as the limited B.B.C. service, the taking over of the French broadcasting stations by the Government and, above all, the amount of news available from abroad on the short waves, have resulted in a vast increase of short-wave listeners. Many short-wave listeners have appreciated that it is not always possible to hear many of these stations at loudspeaker strength and that phones are necessary. Messrs. Ericsson who have specialised in phones for a great number of years inform us that there is a boom in the demand for these instruments at present.

"Short-wave Radio World"

(Continued from page 651)

A medium- μ valve like the 6C5 is recommended, since the higher amplification valves do not have as good modulation capabilities.

The two advantages of the infinite impedance detector over a diode are that it will readily handle high percentages of modulation without distortion and will not load the I.F. transformer. The latter advantage is shared with the ordinary plate detector, but the plate detector does not have the high modulation capability. The infinite impedance detector has the disadvantage, along with the plate detector, that there is no convenient source of A.V.C. voltage.

While not an infinite impedance detector in the true sense of the word, the circuit¹ shown in Fig. 6-C is interesting because it permits the use of a diode rectifier (for A.V.C. purposes) without loading the I.F. transformer. It is related to the infinite impedance detector only in that it is another member of the family of cathode-coupled circuits. A 6C5 or similar tube should be used in this application, and representative values would be $R = 1,000$ ohms, $C = 0.01$ μ fd., $R_1 = 25,000$ ohms, $C_1 = 500$ μ fd., $C_2 = 0.01$ μ fd., $R_2 = 250,000$ ohms, $R_3 = 500$ ohms, $C_3 = 0.1$ μ fd., $R_4 = 500,000$ ohms and $C_4 = 0.01$ μ fd. For an I.F. of 465 kc., L should be of the order of 1 mh., which can be obtained readily by removing some of the turns from a small 2.5-mh. choke. L should be as low-resistance as possible, to avoid bias of the diode. If some capacity is added across the coil, the amplifier will become regenerative, and the circuit is suitable for receivers with regenerative I.F. amplifier and A.V.C. *Radio, Oct., 1939.*

¹ W. T. Corking, "Cathode-Coupled Circuits" "Wireless World," December 15, 1938.



Although television transmission has ceased, development work in the various laboratories is still proceeding. Here are technical details of the latest Scophony big-screen projector which, just prior to the war, was demonstrated in London cinemas of the Odeon group

The Latest SCOPHONY BIG-SCREEN PROJECTOR

The Scophony projector unit with side panels removed. Mechanical scanning is employed and light modulation is by means of the Scophony supersonic light control.

THE Scophony big-screen projector intended for installation in cinemas has been so designed that all the electrical gear is incorporated in the one unit with the exception of the arc rectifier supply which is obtained from the theatre built-in system and great care has been taken that every part of the electrical and mechanical gear can be run well within the limits of the theatre electrical installation.

The light source makes use of a modified type of Hall and Connolly high-intensity arc lamp, running at 100 amps. Light modulation is by the Scophony supersonic light control modified in design to meet the requirements of the increased light necessary for a large picture. The high-speed scanner motor is exactly the same as used in the home receivers and which has been fully described in previous issues of this journal; it consists of a combined asynchronous and synchronous motor run on special ball bearings at a speed of 30,375 r.p.m. The scanner polygon itself is made from solid stainless steel with 20 faces.

The low speed scanner consists of 24 mirrors on a drum diameter of 20 ins. Full use is made of the Scophony split focus optical system

which has also been explained in detail.

49 Valves

In the complete apparatus a total of 49 valves are used, and not one of these valves is of larger type than used in an average broadcast receiver. The aerial is a standard reflector type dipole with balanced feeder input to an EE.50 amplifier valve taking in the full band width and sound and vision carriers. The output from this valve is fed to an EE.50 R.F. amplifier at carrier frequency which is followed by an EF.50 at which the signal strength of approximately half a volt is rectified by a T6D detector.

This is followed by an EF.50 vision frequency amplifier followed by a KT61 cathode follower. On the same chassis is arranged the sound receiver the output of which is taken from the EE50 first R.F. stage to two EF50's R.F. amplifiers working at $41\frac{1}{2}$ megacycles to an EBC3 detector. The output from the double receiver chassis goes to the vision amplifier and synchronising separator panel and also to the sound amplifier panel.

Sound Amplifier

For the sound the output on the EBC3 double diode triode is fed into

a 6F8 amplifier transformer coupled to four KT66 valves in push-pull parallel. This output is fed to four 12 in. moving-coil loudspeakers. The rectifier for the sound amplifier is a U18 and 400 volts are applied to the anodes. A U18 rectifier with 300 volts is used on the radio chassis.

The vision output from the KT61 is fed to a chassis which consists of an EL6 cathode follower valve in the anode of which is connected an EL6 vision frequency amplifier feeding a KT61 anode bend synchronising separator. The output of this is connected to two KT61's in the anode of which is connected a tuned circuit for 10,000 cycle pulses and in the anode of the other a low-frequency circuit for a 50 cycle pulse. A U18 rectifier supplies the high tension for this chassis at 300 volts level.

The cathode output from the EL6 on this chassis is fed through a short concentric cable to the modulated oscillator which drives the light control crystal. This modulated oscillator panel is fixed in the apparatus close to the light control so that only short output leads are used. It consists of an EL6 vision frequency amplifier followed by an EL6 cathode follower modulating a pair of KT66 R.F. amplifiers. A KT61 valve is used as an oscillator. D.C. restoration is accomplished by means of a T6D diode. The high tension and bias supply in this panel comes from three U18 rectifiers delivering respectively 500 volts, 300 volts and minus 200 volts for bias. The oscillator frequency is 18 megacycles.

Power Supply

The output from the two synchronising separator valves is fed to the low-speed scanner motor and the high-speed scanner motor. In the case of the low speed a 6F8 valve is used as a blocking oscillator which is transformer coupled to four KT66

valves connected in push-pull parallel and working as Class B. The output from these valves is fed to the low-speed motor which is a synchronous four-pole type.

The required low speed is obtained by a suitable single reduction gear. The power supply is derived from a U18 rectifier at a potential of 450 volts. The line frequency output is fed to a KT61 with tuned circuit and to three KT66 valves, connected as triodes in parallel, to the synchronous winding of the high-speed motor. Extra D.C. is supplied to this winding and is obtained from a U235 rectifier. A U18 rectifier is used for high tension at a potential of 450 volts.

The asynchronous drive to the motor uses a KT61 oscillator with variable frequency control transformer coupled to two KT66 valves and split into three phase for the asynchronous windings of the high-

speed motor. A U18 rectifier is again used at a potential of 450 volts.

The field supply of the four loudspeakers which are mounted on 8 ft. by 4 ft. baffles (two speakers per baffle) is derived from a U18 rectifier at 200 volts.

Simple Control

The control of the apparatus is relatively simple. The arc is completely controlled by means of resistance switches on the panel and a voltmeter and ammeter suitably arranged so that the operator can see at a glance the arc wattage. The vision controls consist of a picture gain control, a sound gain control and a brightness control. Subsidiary controls are provided in the sound amplifier for base and treble response according to the theatre acoustics.

The screen is a translucent type made specially by Scophony, Ltd.

change of 1 volt in the grid bias.

Accordingly, to measure the slope the grid bias is set at, say, 3 v. and the anode current noted. The bias is then reduced to 2 v. and the increased current again noted, care being taken to maintain the anode voltage constant. The difference between the two anode current readings is then the slope (g) of the valve in mA. per volt at the mean grid bias value chosen (in this case 2.5 v).

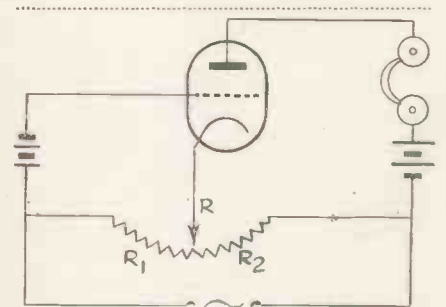

Fig. 2. "Bridge" for measuring amplification factor.

Measuring Valve Characteristics

IN the early days of radio the satisfactory performance of valves was largely determined by the filament emission. The accurate matching of valves to circuits had not assumed the importance that it now has in modern receiver practice and the user of the valve was usually content to

In the old "dull-emitter" types a further test was usually made for filament emission: the so-called "total emission" test. For this the grid and anode were connected and a low positive potential was applied to both. The resulting anode current was taken as the maximum emission of the filament and served as a guide to the filament efficiency and the correctness of the ageing process.

Fig. 1 shows a typical circuit for measuring the static characteristics of a valve. No load is connected in the anode circuit, but the anode and grid voltages are varied by means of potentiometers connected across the bat-

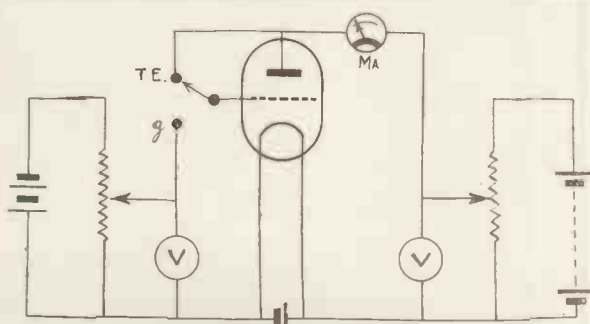

Fig. 1. Typical circuit for measuring static characteristics.

know that the anode current was somewhere near the maker's rating and that the "slope" of the characteristic curve had not deteriorated due to failing emission.

The constants of a valve—the amplification factor, slope and mutual conductance are usually measured by a "static" test, *i.e.*, the valve is not operated under working conditions, but steady D.C. voltages are applied to the various electrodes and the variation in anode current is observed when a slight change is made in any one.

teries. The switch S serves to measure total emission by connecting the grid to the anode in the upper position (T.E.) while in the downward position marked "g" the slope of the valve characteristic can be measured.

The slope is the change in anode current at a fixed anode voltage for a

Mention of "Electronics and Television & Short-wave World" when corresponding with advertisers will ensure prompt attention.

Another constant which can be measured by this circuit is the magnification factor (μ) of the valve. This is the change in anode voltage required to keep the anode current constant when the grid is altered by 1 volt. To measure this, the same alteration is made in the grid bias as before. The anode current is noted at 3 volts bias, but on reducing the bias to 2 volts the anode voltage is then reduced until the anode current reading is the same as before. The magnification factor is then given by the difference in anode voltage readings.

As an example, suppose the anode current were 3 mA. at 3 volts bias and 150 volts on the anode. On reducing to 2 volts bias the anode current rises to say 5 mA. The slope is then 2 mA. per volt. Now the anode voltage is reduced to 130 at which the anode current is the same as before, namely, 3 mA. The magnification factor is then $150-130$ or 20.

The other constant of the valve—the impedance, or A.C. resistance—can be calculated by dividing the magnification factor by the slope and expressing the answer in thousands of ohms. In this case, the anode A.C. resistance is $20/2$ or 10,000 ohms.

The test circuit of Fig. 1 has several disadvantages in spite of its simplicity. The values obtained are only true for the particular static conditions under which the valve is operated and will not necessarily apply when the valve is in a circuit.

Although the readings are easily made by a skilled observer there are several possibilities of error owing to errors in individual meters.

To reproduce more nearly the operating conditions of the valve, it would be necessary to apply an alternating potential to the grid and compare, in the case of the amplification

A similar circuit can be used for measuring mutual conductance (or "slope") and the method depends on the relation given above. If R_a , the A.C. resistance of the valve, is given by μ/g then g , the mutual conductance, is μ/R_a .

The arrangement is shown in Fig. 3 in which a resistance R is connected

As before, the resistance R can be calibrated to read mutual conductance direct.

A number of commercial valve testers and characteristic measuring instruments have been made, based on the principles described above. The non-technical user of a valve is not so concerned with actual values but as to whether the valve is "good" or "bad." Accordingly, for service use, the usual practice is to mark the dial of the indicating meter with arbitrary divisions to show the condition of the valve by its mutual conductance, with an accurate scale in addition to enable the service engineer to make measurements. A typical commercial valve tester is shown in Fig. 4 with an attachment for taking all types of valve base.

The meter has three separate scales. One scale is directly calibrated in mutual conductance in mA./V, and the figure obtained on this scale can be compared with the makers' figure for any valve. Another scale is clearly marked in three colours and shows the state of the valve to the non-technical customer, indicating "good," "indifferent" or "replace" in comparison with the standard mutual conductance. The mutual conductance scale is marked normally and also upside down so that it can be read easily from both sides of the counter.

In addition to giving the static mutual conductance a further scale shows the value of the cathode-to-heater insulation of an indirectly heated valve when the valve is hot. An emission test is also provided for diodes and rectifiers and a test for filament continuity and electrode "shorts" is provided.

The "Avo" valve tester comprises the main meter unit and the new Universal valve panel. The latter incorporates an ingenious rotary selector switch enabling any combination of electrode connections to be easily set up for any one of the twelve different valve holders now in general use for English, American and Continental valves.



Fig. 4. The Avo valve tester with associated universal panel. As explained in the text this is a most comprehensive instrument.

factor, the alternating voltage developed in the anode circuit.

Several methods have been proposed for measuring the constants of a valve under operating conditions. A simple form of "bridge" for measuring amplification factor is shown in Fig. 2. The valve is operated under normal working conditions by adjusting the grid bias and H.T. voltage. An A.C. voltage is applied across the potentiometer R in the cathode circuit. The grid A.C. potential developed across part of the potentiometer R , produces an A.C. component in the anode current which in turn produces a voltage drop across R_2 , the other half of the potentiometer. The slider is then moved until the A.C. voltage applied across R_2 balances the A.C. voltage drop due to the anode current, a pair of phones being used to indicate when balance is obtained. Under these conditions the magnification factor is given by the ratio of the resistance R_2

$\frac{R_2}{R_1}$. If R_2 is fixed in value, R_1 may be marked to read the magnification factor directly on a scale.

This method eliminates the use of meters for obtaining the readings and can be used by semi-skilled observers. For great accuracy, however, it would be necessary to compensate for slight changes in the operating conditions and for stray capacities in the circuit.

in the grid-cathode circuit. If an A.C. voltage e is applied to the grid, the current through R will be given by $\frac{e}{R}$ and this flows through the

phones. At the same time, an A.C. current flows in the anode circuit

which is equal to $\frac{\mu e}{R_a}$ where μ is the

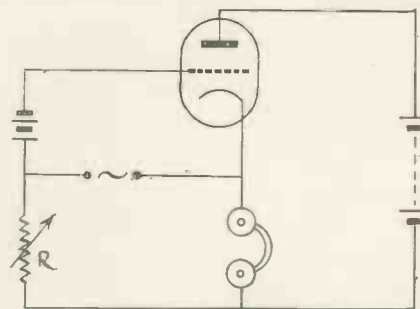

Fig. 3. Method of measuring mutual conductance.

amplification factor and R_a the anode A.C. resistance.

R is now adjusted so that these currents exactly balance and there is no sound in the phones. Then:—

$$\frac{e}{R} = \frac{\mu e}{R_a}$$

$$\text{or } \frac{I}{R} = \frac{\mu}{R_e} = g.$$

Hamrad Wholesale, Ltd., announce that both directors are now engaged, whole time, on National Defence work, but that the concern has neither given up business nor even closed up, but is merely marking time while there is more urgent national work to be done.

A TEST OF A NEW HALLICRAFTER RECEIVER



The Hallicrafter SX-24 which has an outstanding performance.

A receiver which incorporates every refinement that the communication set user is likely to require.

IN a recent issue we gave a description of a new Hallicrafter communication receiver—the SX-24. We have been anxious to thoroughly test this model which particularly interested us for a particular purpose.

The model released to us was taken from its original packing case in which it had been imported from the United States and without any adjustment or realignment whatever was put into operation.

Unfortunately, the full circumstances of procedure cannot be detailed but it will suffice to say that for the particular test it was necessary for the receiver to be left switched on and in operation for 24 hours a day for a period of 8 days. After the first half-hour not a single instance of drift was experienced and the four operators who were using the model in shifts were all amazed at the extreme accuracy of calibration. It was necessary to continually move from one station to another and we found that without exception

and through the whole range of frequencies from 22 to 3.8 mc., the dial could be set at the set frequency and no further adjustment was necessary.

Fortunately for our tests several of the stations to which we were called upon to listen were located in the amateur bands. It will be seen later from the review of the circuit that a separate dial accurately calibrated is fitted to the bandspread drive. Calibrations on this dial were, of course, designed for the use on amateur frequencies only, covering the 28, 14, 7 and 3.5 mc. bands. It was found possible on any of these bands to locate a station with a degree of accuracy .1 per cent.

On many occasions checks were given on the frequencies of incoming signals and proved to line up very accurately with the crystals in use at the transmitting stations. Outside the amateur bands, of course, the calibration on the main tuning dial must be used which,

of course, is not graded into such a fine scale as the bandspread dial, but after a little use speedy calculations can be made of the exact frequencies even on the lower wavebands.

During the last few days the 28 mc. band has been wide open in the early evening and many hours have been spent with the receiver. Also besides the 28 mc. amateur band a wide band of frequencies stretching from 32 to 37.5 have been wide open and full of American Police signals. These signals called for great skill in operation and have previously interfered one with the other. On the SX-24, however, they could easily be separated and both main station call and mobile station reply were picked up on numerous occasions.

Next to accuracy of calibration perhaps the outstanding feature is this selectivity, but it is closely followed by the very high signal-to-noise ratio.

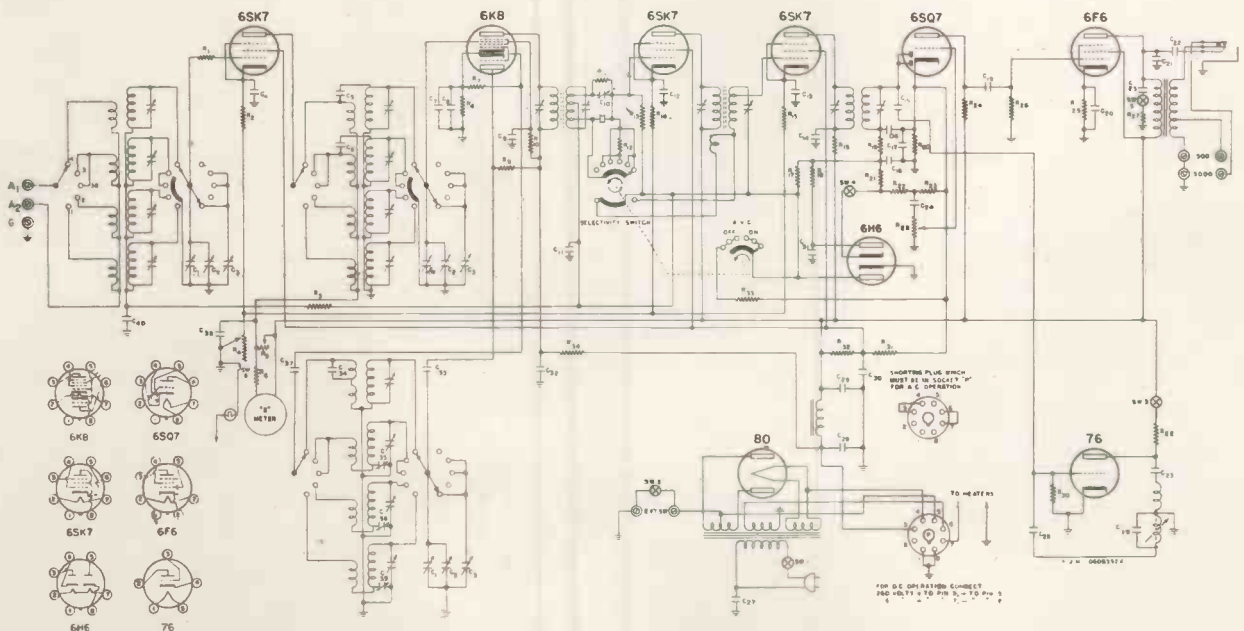

The circuit of the SX-24 with noise limiter, crystal, and frequency meter.

A.V.C. action is good and any signal of R4 and over can be received with an absolutely silent background.

One little feature which was perturbing at first was the apparent insensitivity with C.W. signals. Immediately the beat frequency oscillator switch was closed the instrument appeared to "quieten" and it was not until several minutes had been spent that it was realised that in actual fact sensitivity on C.W. was quite as high as on 'phone. Really heavy C.W. signals did not overload, whereas weak or watery signals could be built up to a fine usable strength.

It was interesting to note the enormous amount of news in English which could be received at practically any time of the day. In fact, one of our chief sources of entertainment during these few days of real hard work operating was listening to the true news and the garbled versions from the foreign propaganda stations. To turn from the Continental stations and hear the review of news from such well-known Americans as WGEA on 19.57 metres and WCBX on 25.36 metres, gives one a far truer picture of the actual state of world affairs than merely listening to our own B.B.C.

The general design and construction of the SX-24 leaves nothing to be desired and below is given a short summary of its many features:—

The Hallicrafter SX-24 tunes from 540 kilocycles to 43.5 megacycles in four bands. The frequencies covered per band are as follows:—

Band.	Coverage..
1	540 kc. to 1,730 kc.
2	1.7 mc. to 5.1 mc.
3	5.0 mc. to 15.7 mc.
4	15.2 mc. to 43.5 mc.

The main tuning dial, which appears behind the large escutcheon, is accurately calibrated in kilocycles on Band 1 and in megacycles on the remaining four bands.

Frequency Meter Tuning

The bandsread dial of the SX-24 model is calibrated so that the operator may determine quite closely the frequency of the signal to which he is listening on the 10 to 80 metre amateur bands inclusive. The outer edge of this dial is marked off in 100 divisions for additional ease in logging and locating stations.

Around the outer edge of the main tuning dial the amateur bands for which "Frequency Meter Tuning" is available are marked with the red numerals; 10-20-40 and 80.

Valve Line-up

The valve line-up is as follows:—
6SK7 R.F. amplifier.

6K8 1st detector-mixer H.F. oscillator.

6SK7 1st I.F. amplifier.

6SK7 2nd I.F. amplifier.

6SK7 2nd detector, A.V.C. 1st stage of audio.

6F6 2nd audio output stage.

6H6 Automatic noise limiter.

76 Beat-frequency oscillator.

80 Rectifier.

Control and Operation

The functions of the various controls are given below. These are from left to right in the photograph.

The "R.F. Gain" control adjusts the sensitivity of the receiver by varying the cathode bias on the R.F. and I.F. amplifiers. Maximum sensitivity will be obtained when this control is rotated as far as it will go to the right. When this has been done a switch will operate which lights the lamp behind the calibrated "S" meter to be described in greater detail later.

The "Band Switch" will allow selection of the frequency ranges through which the receiver tunes.

The "Selectivity-A.V.C. Switch" provides a means of bringing the signal through varying conditions of interference.

When using the receiver for the reception of modulated, or telephone, signals it is advisable to have the switch in one of the three "A.V.C. On" positions at which reception is most satisfactory. The three steps of selectivity, namely: Broad I.F., Sharp I.F., Broad Crystal, will provide control of selectivity sufficient to meet all normal receiving requirements.

For code or C.W. reception, the Automatic Volume Control circuit should be disconnected by placing the switch in one of the 3 "A.V.C. Off" positions. When this has been done the R.F. gain control should be manually adjusted so that the set will not overload or block on extremely strong signals. The maximum selectivity of the receiver is obtainable with the selectivity switch in the "CW. Xtal" position. The received signal will be considerably sharper and as a result more care must be exercised in tuning when the C.W. crystal is in the circuit. In conjunction with the crystal filter the phasing control, when properly adjusted, will prove helpful in coping with conditions of extreme interference. Adjustment of this control for maximum rejection of the unwanted signal, or audio image, will allow true single-signal reception. With the selectivity switch in all other positions but C.W. Xtal, the phasing control should be adjusted for maximum gain.

The "Phone-Xtal" positions are an intermediate step in selectivity between C.W. crystal and I.F. sharp. Phone

signals must necessarily be accurately resonated when operating in the Phone Xtal position or side band attenuation will seemingly reduce the strength of the signal.

The "Main Tuning" control is for adjusting the main dial of the receiver to the desired frequency.

The "Tone-High Low" switch directly below the above control in the "High" position gives natural reproduction. In the "Low" position, the highs are cut off, a condition that will be helpful in receiving signals during certain types of interference.

The "Crystal Phasing" control has previously been described in its association with the C.W. Xtal selectivity position.

The "Band Spread" knob allows smooth back-lash-free operation of the separate band spread condenser and dial.

The "A.N.L." or automatic noise limiter switch will effectively minimise ignition and similar types of interference which would be objectionable to short-wave reception if such a limiting device were not available.

The "A.F. Gain" control turns the receiver "off" and "on" as well as controlling the volume of output.

The "Pitch Control" and its associated "BFO-Off-On" switch provide a beat note for the reception of C.W. signals. The Pitch Control, when the B.F.O. switch is in the "On" position, allows variation of the frequency of the resultant beat note to a pitch most pleasing to the listener.

The "Send-Receive" switch momentarily removes plate voltage from the tubes in the receiver so that the set can be made inoperative during stand-by periods.

Into the "Phone Jack" can be connected any type of high impedance phones because no direct current flows in the headphone circuit.

"S" Meter

When the R.F. gain control is advanced until a switch is heard to operate, a light appears behind the translucent scale of the meter itself. Only when this light is on will the meter indicate in "S" units. With the R.F. gain control backed off from maximum the meter is still in the circuit but will not indicate carrier level accurately. When so adjusted the meter can be used as a resonator indicator.

[We are informed by Messrs. Webb's Radio, who are the sole concessionaires for Hallicrafter equipment in this country, that all receivers imported by them are suitable for operation on A.C. mains of from 110 to 250 volts.

A new consignment of receivers has just arrived, but, of course, in line with all other American equipment, the price has been increased to £24.

NEW!**OSRAM
VALVE TYPE
Z62***A new high gain screened Pentode of exceptional interest***TYPE
Z62****CHARACTERISTICS**

Heater voltage	...	6.3 volts
Heater current (approx.)	...	0.45 amps.
Anode voltage	...	300 max.
Screen voltage	...	150 max.
Mutual conductance at Ea 300, Es 150, Eg-2	...	7.5 mA./volt
Input resistance at 40 Mc./ sec. (approx.)	...	4,000 ohms.
Octal Base, Grid to Top Cap.		

PRICE 12/6 EACH

Experimenters and designers will welcome technical data on a new screened Pentode, the Osram Z62, which incorporates many outstanding features.

POINTS OF THE OSRAM Z62

- 1** The normally long "pinch" is replaced by a shortened design to hold the electrode supports, and results in a great reduction of lead wire length and reduction in lead inductance. This improvement is of real value for short-wave applications.
- 2** A high mutual conductance of 7.5 mA/volt is achieved at the working point. This means more gain per stage with low impedance anode loading, such as in very short wave circuits or wide band amplifiers.
- 3** A high ratio of mutual conductance to total cathode current results in an improved signal to noise ratio.
- 4** Suitable as audio frequency amplifier with high stage gain and low attenuation at the highest audio frequencies.
- 5** Fitted with "international" octal base—no special socket required.

WRITE FOR TECHNICAL LEAFLET WITH FULL DATA

HOME INSTRUCTIONAL COURSE

THE PURPOSE OF THIS SERIES

With the object of filling the gap which has been temporarily caused in the education of the radio student, we are providing a series of articles on various theoretical aspects of radio engineering.

The present position has led to the suspension of evening classes in many of the Technical Institutes and added to the difficulties in attending those that are available. Some thousands of students of radio will miss the opportunity of increasing their knowledge of the theoretical side of the subject. Practice is not always enough to keep abreast of the subject, and the radio engineer or serviceman must understand fully the theory underlying the practice in order to cope with the frequent "out of the ordinary" jobs that come his way.

The articles are not intended to compete with or in any way displace the "correspondence course" in which the subject is dealt with fully from beginning to end, but are aimed to give concise information on certain fundamental theories which will be of direct use to the student in his work.

Each article will be complete in itself and in order to give mental exercise, examples will be given at the end. While we cannot enter into correspondence with readers on the subject matter of the articles, it will be found that the examples given are answered in the succeeding article and numerous explanatory footnotes should make the discussion as clear as possible.

Suggestions are invited from students for special aspects of the subject to be dealt with in later articles.

PHASE AND POWER

TWO MORE RADIO ENGINEERING TERMS

IN articles on audio frequency amplifiers the words "phase angle" and "power factor" are continually occurring. They are particularly prominent in the literature of television, where a phase distortion of a few millionths of a second is noticeable on the picture reproduced. In audio or radio frequency waves, phase distortion affects the quality of reproduction by altering the shape of the complex wave as it is passed through the amplifier.

To understand the meaning of phase distortion, we must first explain the words "phase" and "phase angle," and to do this we return to the sine wave dealt with in the previous article of this series and define one or two more terms.

The sine wave was obtained by plotting sines of angles from 0° to 180° for half a cycle, and plotting the same series of values on the other side of the horizontal axis for the other half-cycle. Expressed mathematically this curve represents the equation $y = \sin A$ where A has values from 0° to 360°.*

If the curve is to represent values of voltage, the vertical scale of y is multiplied by a factor to convert it into voltage values. We know that the voltage at any point on the wave is given by the maximum value multiplied by the sine of the angle, so the equation can be re-written to express voltage values as:

$e = E \sin A$, where E is the peak value.

The dot on the curve of Fig. 1 represents the value of e at 30°, and the equation for this point would be written $e = E \sin 30^\circ$.

deal with special conditions in a circuit occurring when the switch is closed at the peak value of the voltage.

So far as the curve is concerned, we may mark on the diagram of Fig.

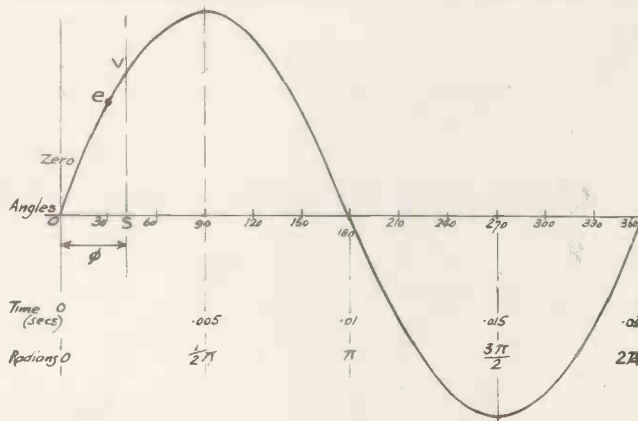

Fig. 1.—Illustrating instantaneous values of "e," and phase angle "φ." Two other horizontal scales are shown.

So far it has been assumed that the voltage and the horizontal scale of angles both start from zero, but there is no reason why this should be so. If we have a circuit supplied by an alternating voltage and close a switch at random there is no guarantee that the voltage will be zero at the instant of closing the switch. It may be at a value "v," and the instantaneous value of current will then be given by v/R in a circuit consisting only of resistance.

It is only for convenience that we draw the curves of A.C. voltage and current as though they started from zero, and in practice we may have to

1 a point "S" where it is assumed that the switch is closed and current starts to flow. This point is the "zero hour" and can be identified by the value of the angle on the horizontal scale. We can consider the wave as starting at a value "v" and at an angle from the zero mark. To take account of this in the equation above, we can modify it as follows:

$v = E \sin (A + \phi)$ where ϕ is the angular distance from zero at which the point of reckoning begins; and "v" is the instantaneous value of voltage at any point on the wave.

We frequently have to deal with

* In writing $\sin A$, the 'e' at the end of 'sine' is dropped.

Special Purchase
OF
"AIR WARDEN"

5-VALVE MIDGET RECEIVERS

for 200-250 v. A.C. Mains.

Completely self-contained in highly polished wood cabinet 12 x 9½ x 9 ins. with built-in Moving Coil Speaker.

Wave range 190-550 metres,
Usual Price £6 - 6 - 0,

OUR PRICE 55/-

The Ideal "Stand-by" Receiver

PREMIER SHORT-WAVE
KITS for OVERSEAS NEWS

Incorporating the Premier 3-Band S.W. Coll. 11-86 Metres without coil changing. Each Kit is complete with all components, diagrams and 2-volt valves. 3-Band S.W. 1 Valve Kit, 14/9. 3-Band S.W. 2 valve Kit, 22/6.

DE LUXE S.W. KITS

Complete to the last detail, including all Valves and coils, wiring diagrams and lucid Instructions for building and working. Each Kit is supplied with a steel Chassis and Panel and uses plug-in coils to tune from 13 to 170 metres.

- 1 Valve Short-Wave Receiver or Adaptor Kit ... 20/-
- 1 Valve Short-Wave Superhet Converter Kit ... 23/-
- 1 Valve Short-Wave A.C. Superhet Converter Kit ... 26/3
- 2 Valve Short-Wave Receiver Kit ... 29/-
- 3 Valve Short-Wave Screen Grid and Pentode Kit ... 68/-

The New Premier
"STAND-BY" 2-VALVE KIT

Specially designed for Home Service and other medium wave reception. Complete Kit of Parts for a S.G. detector and Pentode Output set for 250-550 metres. Including ready drilled chassis and panel, all components, 2-volt valves and full constructional diagrams. Complete Kit with Valves ... 19/6

PREMIER GENERAL PURPOSE TRANSFORMERS.

Introducing a new range of popular priced transformers, compact and efficient. Dimensions, 2½ x 2½ x 2½ ins. with terminal connections. TYPE P.P.I. Push-pull Inter-valve Transformer, ratio 3 : 1 overall, maximum current 6 m/A. Split secondary winding... 6/6

Type C.B.I. Class B Driver Transformer, ratio 1.5 : 1 overall. Suitable for use with all Standard Class B valves... 6/3

Type M.R.I. Universal Output Transformer. Primary current 36 m/A. Single-end or 72 m/A. push-pull. Primary and secondary are tapped to provide eleven ratios. Maximum power capacity 4 watts ... 6/6

PREMIER RADIO
—AS USUAL!

FOR RUSH DELIVERY, MARK YOUR ORDER "ATTENTION D.D."

PREMIER BATTERY CHARGERS

for A.C. Mains. Westinghouse Rectification complete and ready for use. To charge 2 volts at ½ amp., 11/9; 6 volts at ½ amp., 19/-; 6 volts at 1 amp. 22/6; 12 volts at 1 amp., 24/6; 6 volts at 2 amps. 37/6.

HUGE PURCHASE
OF
U.S.A.
MAINS TRANSFORMERS
at less than pre-war prices.

- Input 110 v. + 220 v. A.C. Output 325-325 v. 120 m/A. 5 v. 2 amps. C.T. 6.3 v. 2-3 amps. } 7/6 EACH
- Input 230 v. A.C. Output 325-325 v. 75 m/A. 5 v. 2 amps. 6.3 2-3 amps. C.T. } 6/6 EACH
- Input 200-250 v. A.C. Output 250-250 v. 60 m/A. 4 v. 2 amps. 13 v. 1 amp. } 3/6 EACH
- Input 100-250 v. A.C. Output 300-300 v. 80 m/A. 4 v. 5 amps. C.T. 4 v. 1 amp. } 6/11 EACH

PREMIER 1940 HIGH FIDELITY AMPLIFIERS

Ideal for A.R.P. Alarm Systems. A new Complete Range of 7 High Fidelity P.A. Amplifiers for A.C. or A.C./D.C. Mains operation.

	Kit of Parts with Valves	Completely Wired and Tested
3-watt A.C. Amplifier	£2 - 6 - 6	£3 - 4 - 0
3-watt A.C./D.C. "	£2 - 6 - 6	£3 - 4 - 0
6-watt A.C. "	£6 - 2 - 6	£7 - 0 - 0
8-10-watt A.C./D.C. "	£5 - 5 - 0	£6 - 2 - 6
15-watt A.C. "	£6 - 14 - 0	£8 - 2 - 6
Black Crackle Steel Cabinet 15/- extra.		

REPLACEMENT VALVES FOR ALL SETS.

EUROPA MAINS VALVES. 4 v. A.C. Types A.C./H.L., A.C./L., A.C./S.G., A.C./V.M.S.G., A.C./H.P., A.C./V.H.P., A.C.P., all 5/3 each. A.C./Pens. I.H., 6/6; A.C./P.X.4, 7/3; Oct. Freq. Changers, 8/6; Double Diode Triodes, 7/6; 3½-watt D.H. Triode, 7/6. 350 v. F.W. Rect., 5/6; 500 v. F.W. Rect., 6/6. 13 v. 2 amps. Gen. Purpose Triodes, 5/6; H.F. Pens. and Var-Mu. H.F. Pen., Double Diode Triodes, Oct. Freq. Changers, 7/6 each. Full and Half-wave Rectifiers, 6/6 each.

TRIAD U.S.A. VALVES.

We hold the largest stocks of U.S.A. tubes in this country and are sole British Distributors for TRIAD High-grade American Valves. All types in stock. Standard types, 5/6 each. All the new Metal-Class Octal Base tubes at 6/6 each. 210 and 250, 8/6 each.

CLEARANCE LINE U.S.A. VALVES.

U.S.A. Types, 24, 30, 41, 39/44, 35/51, 55, 56, 57, 58, 71, 77, 78, 85, 2A5, 2A6, 2A7, 2B7, 6A7, 12Z3, 210, 250, all 2 for 3/-. PREMIER S.W. H.F. Chokes, 10-100 metres, 9d. each. Pie-wound, 1/6 each. Screened, 1/6 each. SHORT-WAVE COILS, 4- and 6-pin types, 13-26, 22-47, 41-94, 78-170 metres, 2/- each, with circuit. Premier 3-band S.W. coil, 11-25, 19-43, 38-86 metres. Suitable any type circuit, 2/11. UTILITY Micro Cursor Dials, Direct and 100 : 1 Ratios, 4/3.

SHORT-WAVE CONDENSERS

TROLITUL insulation. Certified superior to ceramic. All-brass construction. Easily ganged.

15 m.mfd. ... 1/9	100 m.mfd. ... 2/3
25 m.mfd. ... 2/-	160 m.mfd. ... 2/6
40 m.mfd. ... 2/-	250 m.mfd. ... 2/11

PREMIER 1940

"5 v. 5" COMMUNICATIONS RECEIVER

A 5-valve Superhet, covering 12-2,000 metres in 5 wave bands.

- Beat Frequency Oscillator
- 2-Spread Band-Spread Control
- A.V.C. Switch
- Illuminated Band-Spread Dial
- Send-Receive Switch
- Iron-Cored IF's
- Phone Jack
- Over 4-Watts Output

Provision for single wire or Di-pole Aerial. International Octal Valves for 200-250 v. mains (A.C.). Built into Black Crackle Steel case providing complete screening, 10½ in. Moving Coil Speaker in separate steel cabinet to match.

Receiver, complete with all tubes and Speaker, £9 9 0

NOW READY! OUR GIANT 1940 ILLUSTRATED CATALOGUE AND VALVE MANUAL —OVER 100 PAGES— PRICE 6d.

PREMIER RADIO CO.

ALL POST ORDERS to:—Jubilee Works, 167, Lower Clapton Road, London, E.5. (Amherst 4723.)
CALLERS to:—Jubilee Works, or 169 Fleet St., E.C.4. (Central 2833) or 60 High St., Clapham, S.W.4. (Macaulay 2381)

The Unit of Angular Measure

two waves simultaneously in radio practice, one of current and one of voltage. These may not both start at the same point, but we can measure the time difference between them in terms of the angle distance on the horizontal scale. Fig. 2 shows two waves drawn on the same horizontal axis. At the instant of time "t" when we close the switch, one wave is at a value "v" and the other one is at zero.

The "angular" distance between them on the horizontal scale is " ϕ " degrees, and we may here make the definition:

If two waves are plotted on the horizontal axis, so that their zero points are ϕ° apart, they are said to have a "phase displacement of ϕ ." If we consider the direction of the time or angle scale to be in the direction of the arrow, from left to right, the wave which reaches its maximum value first from the start is said to be "leading" on the other. If it is at its maximum later in point of time it is "lagging."

We can thus express the relative position of two waves by giving the phase displacement in degrees and stating whether the one we are considering is leading or lagging on the other.

Time Scales

The scale of angles used in drawing the curves can be easily converted into time values if we know the frequency of the wave. For example, at 50 cycles a complete wave is drawn in $1/50$ th sec. The total length of the angle scale for a complete cycle is 360° and we therefore have $10^\circ = .02 \times 360$ or .00056 approximately. The fractions of a second corresponding to the angular measure are marked on Fig. 1. The phase displacement can either be expressed in seconds or in angle, the latter being more usual. For television work, however, it is usually necessary to convert into actual time interval as phase displacement is expressed with reference to scanning speed or distance moved along a line of the picture.

In electrical calculations affecting the flow of current through an inductance or condenser the frequency of the wave is of prime importance as the properties of inductance and capacity depend on the "rate of

change" of current through the circuit.

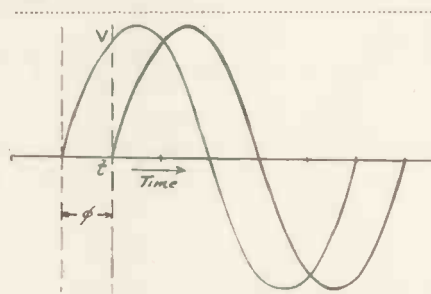

Fig. 2.—Two waves differing in phase by an angle " ϕ ."

In these calculations the angular measure that we have been using above is not brought in in its usual form but is expressed in *radians*. The radian is an angular measure, but might be described as a mathematical angular measure since it is based on the property of the circle and not on an arbitrary division into degrees. If we take a circle and mark off on the circumference a curved length equal to the radius, we get, on joining the two extremities of the line to the centre, an equilateral triangle with a curved side. The angle at the centre is then called *one radian*. It is thus the angle at the centre of the circle made by an arc of the circle equal in length to the radius. The significance of the radian is that it is a definite fraction of the circle in magnitude. The total length of the circumference is 2π times the radius, and it therefore follows that there are 2π radians in the complete circle of 360° . This is shown more clearly in Fig. 3. We can add a further scale to the horizontal axis in Fig. 1, marking it "radians" and it will be seen that the $\frac{1}{2}$ -cycle is π radians and the whole cycle is 2π radians.

The e.m.f. induced in a rotating coil, such as we used to see the origin of the sine wave, depends on the speed with which the edge of the coil moves through the magnetic field: that is, its *angular velocity*. The faster the coil rotates the greater the angular velocity and the greater the e.m.f. developed for a given strength of field. The angular velocity of the coil can be expressed by the number of radians that it turns through in one second—if it turned through 2π in one second it would be rotating at 1 revolution per second.

This angular velocity is usually designated " ω ," and the angle which the coil has turned through in "t" seconds is therefore " ωt ."

Instead of writing $e = E \sin A$ in the formula above, we can therefore write $e = E \sin \omega t$.

Now, in one second the coil rotates through ω radians, since the angular velocity is ω radians per second. But one cycle of e.m.f. is equal to 2π radians. The frequency of the wave is therefore the number of 2π radians in ω radians, or $\omega/2\pi$.

Rewriting this fraction, we have $\omega = 2\pi f$, where f is the frequency in cycles per sec., and substituting in the equation above, $e = E \sin 2\pi ft$.

The physical meaning of the equation is that after an interval of "t" seconds from the start of any wave the value of the e.m.f. is proportional to the peak value multiplied by a constant which is 2π times the frequency. For 50 cycles, ω works out to 314 approximately. This factor is used in calculations of impedance and we shall meet it again later on.

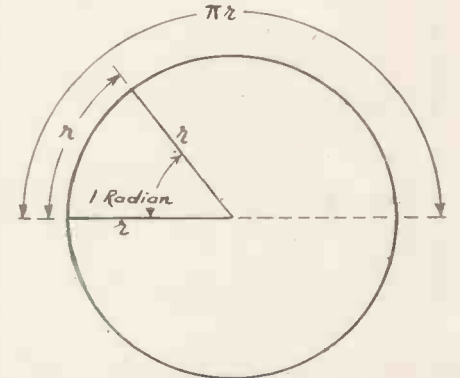

Fig. 3.—The definition of a radian. There are π radians in 180° , since the half circumference is π times r .

Power

If a sine wave of voltage is applied to a pure resistance, the current through the resistance at any instant will obey Ohm's law and will be equal to the instantaneous value of the voltage divided by the resistance. From the previous article, we can also say that the r.m.s. value of the current will be equal to the r.m.s. value of the voltage divided by the resistance. The power expended in the resistance will then be given by multiplying the r.m.s. values of voltage and current together, as in the case of D.C.

(Continued on page 670)

Specified by  the Experts
SOUND SALES

CHOKES AND TRANSFORMERS



"TO SPECIFICATION"

We have a special section of our factory devoted entirely to the design and production of Chokes and Transformers to individual specification.

Whilst our range of standard lines is quite a large one, we realise that they cannot meet every individual need ; hence our special department for quoting and producing to the exact requirements of our customers. A Sound Sales service which has been of value to practically every well-known laboratory and Government Department including the Air Ministry, the G.P.O., the War Office, etc.

This Sound Sales service is open to all readers of this journal.

May we send you our latest Catalogue and Technical Manual ? Price 6d., post free.

SOUND SALES LTD.,
 WEST STREET, FARNHAM, SURREY
 Telephone : Farnham 6461



'AVO' ACCURATE TESTING INSTRUMENTS

DESPITE the influx of work of National importance, orders for "AVO" Instruments are being executed with the minimum possible delay. The full "AVO" range is being maintained, and customers are urged to place their orders as far in advance as possible. This will assist us, not only to satisfy the requirements of our trade customers, but will also facilitate the smooth working of our efforts in the National interest.

The word "AVO" is our registered Trade Mark.

Send for descriptive literature and current prices.

THE AUTOMATIC COIL WINDER & ELECTRICAL EQUIPMENT Co., Ltd.
 Winder House, Douglas Street, London, S.W.1. Phone : VICTORIA 3404-7



"Nowadays" said that knowing chap Hughes,
 "One can't risk ever missing the news,
 So to keep my new set
 On the job you can bet—
 For the wiring it's FLUXITE I choose !"

See that FLUXITE is always by you—in the house—garage—workshop—wherever speedy soldering is needed. Used for 30 years in government works and by leading engineers and manufacturers. Of Ironmongers—in tins, 4d., 8d., 1/4 and 2/6. Ask to see the FLUXITE SMALL-SPACE SOLDERING SET—compact but substantial—complete with full instructions, 7/6. Write for Free Book on the art of "soft" soldering and ask for Leaflet on CASE-HARDENING STEEL and TEMPERING TOOLS with FLUXITE.

To CYCLISTS ! Your wheels will NOT keep round and true unless the spokes are tied with fine wire at the crossings and SOLDERED. This makes a much stronger wheel. It's simple—with FLUXITE—but IMPORTANT.

THE FLUXITE GUN

is always ready to put Fluxite on the soldering job instantly. A little pressure places the right quantity on the right spot and one charging lasts for ages.
 Price 1/6, or filled 2/6.



ALL MECHANICS WILL HAVE

FLUXITE

IT SIMPLIFIES ALL SOLDERING

FLUXITE LTD. (DEPT T.V.) DRAGON WORKS, BERMONDSEY ST., S.E.1.

THE DESIGN OF INTERCOMMUNICATION LOUD SPEAKERPHONES

THE telephone, in spite of its universal use, has certain well-recognized disadvantages. For example, it is limited in its range as an instrument. The user must be close to it to answer and once answered, his hands are tied. He can only fumble for papers with a free hand or attempt to write using an elbow to steady the paper. How many times does one leave one's desk to answer a 'phone at the other end of the room and have to return to find the information asked for!

These disadvantages would be overcome by replacing the earpiece with a loudspeaker. The user could then have his hands free and could lean forward to speak into the mouth-piece. But if the microphone were at the same time made so sensitive that it would pick up speech clearly at a few yards distance, then many of the grumbles at the present telephone instrument would be unnecessary.

It is with the object of doing away with the drawbacks of the telephone that the modern intercommunication loud speaker telephones have been designed. As soon as the loud-speaker replaces the earpiece with its limited range, a conversation can be shared by a number of listeners. They can take part in a discussion or refer to others without the trouble of "holding the line."

A typical example of the modern loudspeaking communication system is the Ediswan "Loudspeakerphone."

The equipment consists of a master-unit and extension-units up to six in number. The master-unit comprises a two-stage A.C. mains L.F. amplifier, loud-speaker-microphone, and a switching arrangement for communication in both directions—with a maximum of six extension units.

The extension units each contain a loud-speaker microphone; a buzzer (for calling by the master-unit); and an "on" and "off" switch. In the "off" position, the extensions are in circuit to receive the master-unit's buzzer signal, and are therefore always at call.

The master-unit (except when its

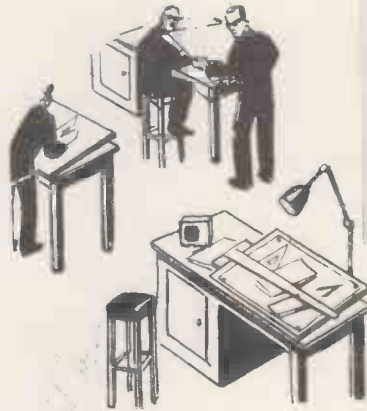

operator chooses to switch off in order to ensure freedom from interruption), is called up orally by the extension units.

No extension unit can listen-in to the "master's" conversation with another extension unit, nor can the master-unit eavesdrop on an extension unit with its switch in the "off" position. It is not possible for extensions to speak to each other; thus, no two extensions can be engaged on the system, when the "master" wishes to speak to either. The equipment is essentially for the "master's" convenience. He can address all extensions simultaneously, or in any desired combination.

Positive Switching

In the master-unit are three main controls:

(1) The *Volume Control* (for regulation from whisper-pitch to full loud-speaker strength) with which control is incorporated an "on" and "off" switch connected in the mains circuit.

(2) the *Selector Switch*; a six-way key-switch to permit extension units to be placed in circuit in any desired combination; and

(3) the *Control Key* with the three positions, call, listen and talk. The key is spring-loaded, with "listen" as the normal position. Upward deflection of the key operates the buzzer in the called-up extension unit. The key is depressed to talk, and further depressed to "stay put" for sustained conversation.



Tonal Quality and Audibility

A characteristic of the Ediswan loud-speakerphone is the excellent tonal quality of reception. The range of audibility is extensive. It is easily possible for the operator of the master-unit, in conversational tone, to speak to and hear a person situated 50 ft. or more from an extension instrument located in a distant room. This is a marked convenience as, for example, an assistant in a general office can be consulted without taking him away from his work—as happens in the ordinary way on a called-to-the-phone interruption.

Since there is no mains voltage between the master and extension units, installation can easily be carried out, and is a matter of leading a multi-core cable from the master-unit to a distribution rose, thence running a twisted bell-wire to each of the required extensions. In accordance with modern practice a triple flex is used for mains and earth. The extension-units lines terminate on special captive-screw terminals marked 1 to 6, on the rear of the chassis.

Running costs are negligible, as it is only the master-unit which consumes current. The consumption compares with that of a 40-watt lamp.

As an example of the application of the instrument we can take the case of a theatre stage-manager. From his station at the prompt side of the stage he can be in touch (without shouting) with the front of the house, the orchestra, the stage carpenters, the property master, the electrician, the "flies." He can convey an urgent message to any one extension unit, to any combination of extension units, or to all of them at once; and any

If your speaker doesn't pull in S.W. Stations these **Ericsson** telephones **WILL**



This is the day of the S.W. stations—most of the most interesting and vital war news is diffused on S.W. Don't be downhearted if your two or three valve S.-Waver doesn't do a good job on the speaker—hook up a pair of **Ericsson Supersensitive Telephones**—and get "all that's going." They turn S.W. whispers into SHOUTS. Wonderfully sensitive, comfortable in wear and very pure in tone. Ericsson Supersensitive Headphones have come to be regarded as standard for the keen short-wave enthusiast's equipment

At all good dealers. If you have any difficulty write to :

ERICSSON TELEPHONES LTD.

22, Lincoln's Inn Fields, W.C.2

Tel: HOLborn 6936



ENGINEERING TRAINING in Wartime

Great range of posts is being offered by Industry and the Government to technically trained engineers. Best study method is HOME-STUDY with The T.I.G.B. which the black out and travel difficulties do not affect. Write TO-DAY for "The Engineer's Guide to Success" containing the world's widest choice of engineering courses covering all branches and recognised qualifications such as **A.M.I.Mech.E., A.M.I.E.E., A.F.R.Ae.S., A.M.I.R.E., A.M.I.T.E., C. & G.** etc. The T.I.G.B. Guarantees training until successful for the one fee.

Free!



THE TECHNOLOGICAL INSTITUTE OF GREAT BRITAIN

160, Temple Bar House, London, E.C.4. (Founded 1917 20,000 Successes)

Static and Dynamic Electricity

By WILLIAM R. SMYTHE

Associate Professor of Physics, California Institute of Technology

560 pages, 9 x 6, illustrated, 40/- net
(International Series in Physics)

THIS book formulates the basic laws of electrostatics, magneto-statics, and electromagnetic theory, by concise vector methods, from the underlying experimental facts. It gives an extended treatment of the mathematical technique for applying the laws to specific problems. Although the theory is completely developed from basic experimental facts, the emphasis is on problems, most of which have been worked out in the text. Five hundred more, most of them with answers, are included at the ends of the chapters.

Contents

Basic Ideas of Electrostatics	Transient Phenomena in Networks
Condensers, Dielectrics, Systems of Conductors	Alternating Currents
General Theorems	Eddy Currents
Two-Dimensional Potential Distributors	Magnetism
Three-Dimensional Potential Distributors	Electromagnetic Waves
Electric Current	Special Relativity and the Motion of Charged Particles
Magnetic Interaction of Currents	Static Electrical Properties of Matter
Electromagnetic Induction	Appendix. Tables. Index

Universal Electrical Co.

221, CITY ROAD, LONDON, E.C.1.

Telephone : CLERK 7030

- Photo Electric Cells, 15/- each.
 - Mercury Relay Valves (American) or use with above valves if necessary, 10/- each.
 - Champion Radio Valves in stock.
 - Transformers 110 to 230 volts, 12 volts input, 15/- each ; 240 volts input, 6 volts output, 6/- each, suitable for trains and models.
 - Claude-General Neon Transformers input 200/240, output 3,000 volts, .1 K.V.A., 10/- each.
 - D.C. Electric Drills, 230 volts, 30/- each.
 - Sliding resistances, 400 and 800 ohms, 7/6 each. Centrifugal Pumps, AC/DC, 59/6.
 - Sets of "G.E.C." Filters, 5/- each.
 - Anti-Interference Units, pair of H.F. Chokes and pair of .1 T.M.C. Condensers, 2/6 the set.
 - New 30th H.P. Universal Motor, 200/250 volts, 27/6 each.
 - American "Weston" Set Analyser, A.C./D.C., 1,000 ohms per volt, 2 Meters, £4/10/-.
 - "Ferranti" Line Transformers, new, 6/- each.
 - "Foster" Double Wound Transformers :
 - 110 to 230 volts 500 watts, 50/-
 - 110 to 230 volts 1,000 watts, 80/-
 - 110 to 230 volts 2,000 watts, 100/-
 - 110 to 230 volts 3,000 watts, 130/-
 - 110 to 230 volts 5,000 watts, 190/-
 - Weston Milliamper Meters, 0-200 15/- each. Weston Ammeters 0-30 15/- each
 - " " 0-250 15/- D.C. Meters 0-2,500 15/- "
- All Types of Rotary Converters sold and purchased.

McGraw-Hill Publishing Co. Ltd.

Aldwych House,

London, W.C.2

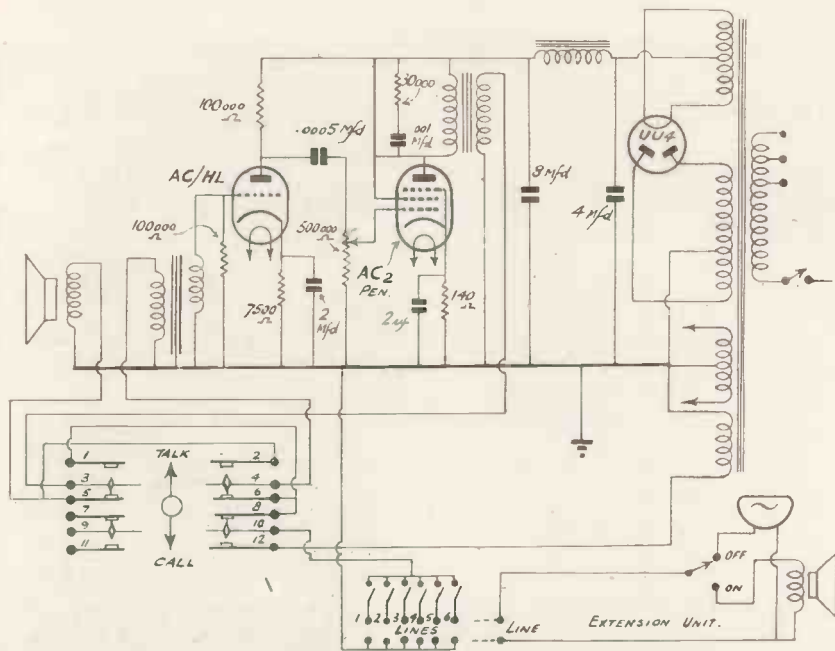

Diagram showing circuit of loudspeakerphone master-unit, and (inset) circuit of extension unit.

one can speak to him—unless, for his own reasons, he chooses to be shut off from interruption.

Circuit Details

The speech amplifier is of the stan-

ard type as shown in the circuit diagram. A Mazda AC/HL is R.C. coupled to a Mazda AC/2Pen output pentode, in the anode circuit of which is the output transformer feeding the extension speaker.

To prevent "boomy" speech the coupling condenser is of low value, and volume is controlled by the grid potentiometer shown in the AC/2Pen circuit.

The control switch in the normal mid-way position connects the loudspeaker of the master-unit to the output of the AC/2Pen and the extension speaker to the input transformer. On the "talk" position the connections of the speakers are reversed and the master speaker feeds the AC/HL grid.

For calling, a small voltage from the mains transformer is supplied to a buzzer in the extension unit when the master switch is put to the "call" position.

To avoid unnecessary noise reaching the master-unit when the extension speaker is acting as the microphone a separate disconnecting switch is fitted in the extension unit. On hearing the buzzer the "callee" switches on his extension speaker and answers in the usual way. When the conversation is finished the speaker can either be switched off or left "alive" for further use.

C.R. Tube Anode Support

WHEN a cathode-ray tube is operated with electro-magnetic coils, it is desirable to arrange these as near as possible to the axis of the tube, in order to obtain good field strength. An obvious way of achieving his result is to narrow the tube envelope in the neigh-

bourhood of these external coils, which gives an envelope shape exhibiting a constricted middle region.

the accompanying illustrations, Fig. 1 shows the anode assembled while Fig. 2 shows the details of the supporting device.

Referring to Fig. 1, the tube wall has a constriction indicated by A. The cylindrical anode B is supported inside the constriction by means of cones C and D of which the latter is divided into a number of sectors as shown more clearly in Fig. 2. These sectors are fixed on to metal strips E, which are all held at their other end in a common support F, which may conveniently be of annular shape.

The assembly of the anode may be carried out in the following way. First, the integral cone C is pushed over the split cone D and metal strips E, and this unit is introduced into the tube constriction. Then the cylindrical anode B is pushed into the tube pressing the cone sectors D against the wall. A threaded sleeve G may be screwed on to the support ring F, thus enabling the metal strips E to be kept under tension, and the metal strips may also be provided with contact springs H, as shown.

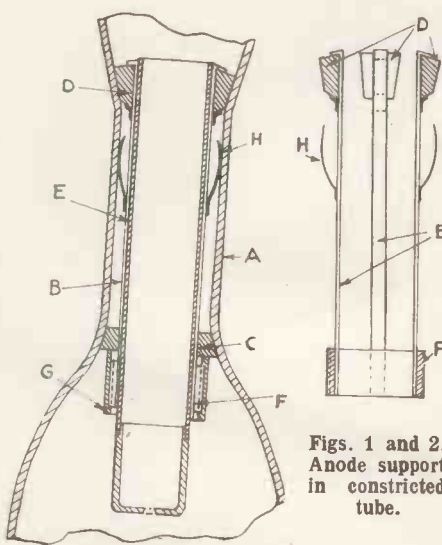

Figs. 1 and 2. Anode support in constricted tube.

Use may conveniently be made of this construction for supporting a cylindrical anode within the tube. In

ELECTRADIX

DETECT ENEMY FIRE BOMBS with a photo-cell night watchman. You can make one yourself to indicate in the A.R.P. room. Battery or mains. **RAY DETECTOR.** Complete kit, battery model with Relay, £3 17 6. A.C. Mains set, £5 10. D.C. Mains sets, £4 15. **PHOTO-CELLS.** R.C.A. caesium silver vacuum £5 list, for 25/-. Electro-Photonic photo cells generate E.M.F. under light 1 1/2" x 3/4", 22/6. Few only left. **DISC SELENIUM CELLS** light to dark resistance ratio mounted in bakelite case, 8/6; in brass housing superior model, 10/6. **RELAYS.** Ultra sensitive moving coil relay 1,000 ohm coil, closes circuit on 50 micro amps., 60/- 2,000 ohm 5 m/A. lightweight magnetic relay, 10/6. **RAID BELLS. ALARM BELLS.** Mains, battery or magneto waterproof types. Large selection. Priority or A.R.P. **POCKET HEADPHONES.** W.D. all leather headband strap and cords, 2/6 pair. Wireless type, with aluminum headbands, 3/9. 4,000 ohms, 4/6. **LISTENING MIKES.** Steel clad Electradix indestructible; are ears outside your dug-out. Details and price on request. Write for large Bargain List "E.T." Electrical, Mechanical, Radio and Scientific Instruments. Please mention "Electronics." Thank you.

ELECTRADIX RADIO

218, Upper Thames Street, London, E.C.4
Telephone: Central 4611

CLIX

FLEXIPIN Self-Adjusting PLUGS

If your radio **CRACKLES** when you touch the plug which connects your set to the wall socket, it is because the plug-pins are not making proper contact with the socket-tubes.

The CLIX plug has been specially designed to eliminate this trouble and its self-centering, expanding pins will fit and make perfect contact in any make of BSS Socket.



CLIX
5 amp 2-pin
"M" type
plug as used
by all the
leading radio
manufacturers

Costs
only **4 1/2**

A full range of 2 and 3 pin BSS types in 2, 5 and 15 ampere sizes is available from all good Radio and Electrical Dealers.

FIT "CLIX" and CUT THE CRACKLE

CLIX

SAFWAYS ADAPTORS

You can use your Radio and other electrical appliances in any room and secure their full benefit throughout your home by fitting a **SAFWAYS** Adaptor in your existing lampholder. To nullify the depressing effects of the "Black-out" fit a **SAFWAYS** adaptor with a low-wattage lamp in the branch outlet and the usual lamp in the other. You can then enjoy normal lighting knowing that, should it be necessary, dimmed lighting can be switched on at a moment's notice.



This particular arrangement can also be used as a night-light for children or invalids, but is merely one of many ways in which **SAFWAYS** can increase the convenience of your electrical installation—quickly, cheaply and safely.

ASK YOUR DEALER for "SAFWAYS"

Single Switch, **1/10**; Double Switch, **2/3**;
Cord Control **2/6** each.

A **CLIX** product made by:—
BRITISH MECHANICAL PRODUCTIONS LTD.
1, Church Road, Leatherhead, Surrey

Fixing Wires on Insulating Panels

IT is frequently necessary in the construction of wireless and television equipment to fix wires to insulating panels.

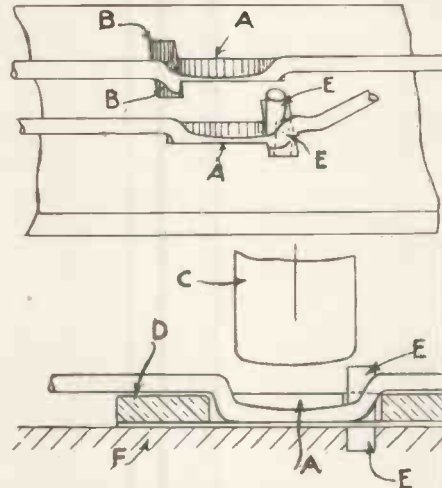

Figs. 1 and 2.—A recently developed scheme for securing wires to insulating panels.

The insulating panel is provided with T or cross-shaped slots A and B as shown in the drawing Fig. 1, the width of the slots being slightly less than that of the wire. The wire is then laid over the slots and pressed down into them by means of a die (Fig. 2). As an additional precaution against the wires jumping out of the slots, it is possible to allow the die to squeeze the wire laterally into the walls of the slots.

In order to avoid distortion of the wires and to prevent them from jumping out of the slots during the pressing operation, they may be kept in position by special pins E. These pins may be attached to the tool which presses the wires into the slot in such a way that before the die makes contact with the wire the pins surround the wire from two sides and keep it in position by engaging with recesses provided in the insulation plate at the side of the wire or so that they move back into the tool. Instead of attaching the centre pins to the die they may be attached to the base plate and thus project through free recesses, not covered by the wires, from the insulation plate D. When the wires are mounted the insulation plate D is removed from the base plate F and therefore also from the pins E. If several rows of wires have to be mounted on the insulation plate next to each other the T shaped slots may be arranged in staggered formation or to follow each other alternately.

YOUR BLACK-OUT NIGHTS WILL BE FULL OF INTEREST IF YOU HAVE THIS ALLWAVE ALLWORLD EDDYSTONE RECEIVER

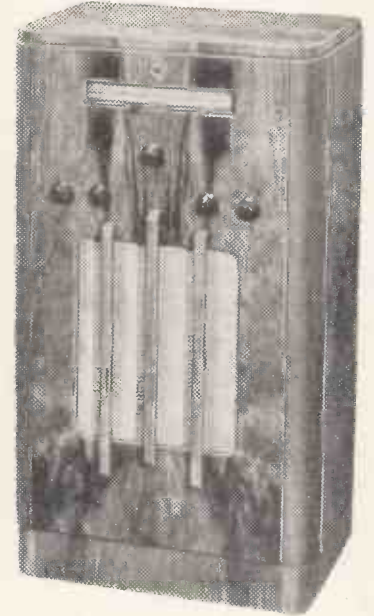

No longer will you be restricted to Local programmes—if you install this thrillingly interesting "**EDDYSTONE**" Seven-valve All-wave All-world Receiver. Each evening you'll come home to an ever-changing interest—a never-fading appeal—that will rob long evenings of their present dullness and invest them instead with recreational delight.

This "**EDDYSTONE**" Seven-valve Mains Receiver will give you **HIGHLY INTERESTING WORLD-WIDE RECEPTION**. It has four wavebands, i.e., 13-33 metres, 31-85 metres, 200-555 metres, and 900-2,100 metres. On the short wavebands you will **ALWAYS** find unlimited interest—something **EXTRA**—news from all countries of world events, interesting official and other communications, American amateurs, etc. Features of this outstanding set are special chassis and special coil unit construction, Automatic volume control, special intermediate frequency stage, H.F. amplifier, "Magie Eye" for accurate tuning, separate oscillator valve to eliminate frequency drift, tone control output, power pentode valve giving 5 watts undistorted output, 12-in. loud speaker, gramophone pickup, and external speaker terminals.

Chassis and Moving Coil Speaker - - 21 Gns
In Magnificent Oak or Walnut Cabinet - 25 Gns

GET IN TOUCH NOW WITH STRATTON & Co., Ltd.

Eddystone Works, Bromsgrove St., Birmingham.

OR SERVICE DEPOTS

WEBB'S Birmingham: 133 New St., 41 Carrs Lane & 123 Shirley Rd. London: 14 Soho St., W.1



For the World's 6.5 to 545 metres
WAR NEWS plus
Radio Entertainment

TROPHY
 Short Wave Receivers
NO CENSORSHIP and no delay is exercised in those short-wave bulletins transmitted in ENGLISH—day and night—from every part of the world. . . . Hear all these and a host of entertaining programmes also. The TROPHY A.C. 6 (illustrated) is inexpensive and dependable for all-world short-wave and B.B.C. listening. Electrical bandspread tuning. Built-in speaker. Aligned and ready for use. Price £10 19s. 6d., carriage paid. Deferred terms available. A TROPHY is the ideal receiver for the home in these stirring days. Order NOW.

TROPHY 8
 Super 8-valve communication model. Wave-range 10-550 metres continuous. Bandspread tuning. R.F. on all bands. Usual tuning features. Complete in cabinet. Price £13 17s. 3d. Cabinet P.M. Speaker to match, 46/3 extra.

TROPHY 3
 A.C. and Battery Regenerative 3-valvers, outstanding in performance and value. Continuous w/range, 6.2-550 metres. Calibrated scale. Built-in speaker. Phone jack. Battery Model, £6 6s. 6d. A.C. Model, £6 18s. 9d., with coils for 12-52 metres. 18/6 extra if coils required for complete coverage. 6.2-550 metres.

PETO - SCOTT CO. LTD.
 77 (T3), City Road, London, E.C.1. Tel. Clissold 9875
 41 (T3), High Holborn, London, W.C.1. Holborn 3248.
 West End dem's. R.E.M. LTD., 70 Wigmore St.
 SEND FOR LISTS

RADIOMART

Business as usual

LARGE STOCKS OF ALL TYPES OF SHORT-WAVE AND COMMUNICATION EQUIPMENT INCLUDING AMERICAN VALVES

Accredited Agents for **NATIONAL**

CONTRACTORS TO: G.P.O., Air Ministry, Crown Agent for Colonies, Signal Corps, Police Forces, etc.

RADIOMART

44, HOLLOWAY HEAD, BIRMINGHAM, 1.
 Telephone: MIDLAND 3254.



Dits and Dahs!

The language of the air that all amateurs should know. **CANDLER CODE COURSES** not only teach you the right way to send, but the right way to read code sound just as easily as you read print by sight. Courses for Beginners and Radio Operators. Terms: Cash or Monthly payments.

Send for FREE "Book of Facts"

LONDON OFFICE
CANDLER SYSTEM CO. (66B), 121 KINGSWAY, W.C.2

"Electric Discharges at Low Gas Pressures"

(Continued from page 646.)

is opposed by the resistance offered by the gas molecules, which force the electrons to move in zig-zag paths. If we could follow one electron, we should see that it seldom travels more than about one tube diameter in the direction of the axis. It hits the wall in its violent random movement, recombines there with a positive ion, and is replaced in the plasma by another electron, freshly formed by ionisation.

From this picture we can at least outline a quantitative theory of the column. In a given tube, at a given gas density, we have the following main quantities: Electron temperature T , electron density n/cm^3 (practically equal to the ion density), current intensity J , and voltage drop (gradient) G volts per cm. These are four quantities, and there must exist three relations between them, so that eliminating n and T we obtain a relation between the current and the gradient, which is called the characteristic of the column.

It can easily be seen how these three equations can be obtained. The first is the ion balance equation. For every ion lost at the wall, a new one must be produced in the plasma. The second equation is given by the conservation of energy: the input per unit tube length $J.G$, must be equal to the losses per cm. length. These losses are generally made up of three items, as follows:—

- (1) Heat developed in the gas.
- (2) Heat developed on the walls.
- (3) Radiation.

A third and last equation is supplied by the mobility equation of Langevin. This expresses the drift velocity of an electron as a function of the gradient and of the gas density. It turns out to be directly proportional to the former and inversely to the latter. We can easily transform this into an equation connecting J , n , and G .

This is the programme of a theory of the positive column, which has been outlined by several authors, although it has not yet been worked out in full detail in any particular instance; this, however, is hardly necessary. The theory of gas discharges need not develop into a theory like that of electric motors or transformers. There is no necessity to prepare discharge lamps on the drawing board. What we can expect from the theory is that it shall help us to understand the pheno-

mena, and to point the way for further experiments. We can show that the theory already in its vaguely outlined form can give us some valuable information.

The first important consequence of the theory is that the gradient ought to be independent of the current. Let us assume that we have a solution of the equations for a certain current, and we want to double the current. All we have to do is to double the electron density (n) and leave everything else constant. The double number of electrons will transport the double current, the input and the losses will also be doubled, but the gradient remains the same.

Let us compare this conclusion with the experimental results (see Fig. 14). At first it appears that we are faced with a gross failure of the theory. Let us remember, however, that in the approximate theory we have assumed that all the time we are dealing with *the same gas*, whereas we really have to deal with a mixture of the normal gas and excited atoms in all possible states, of which the proportion of metastables is particularly notable. This mixture, however, will change with the current. If we increase the current, there will be more collisions per unit volume and time, and therefore we shall have more excited atoms, particularly more metastables. We shall have, therefore, the normal gas, and an admixture that is more easily ionisable, and the proportion of which increases with increasing current.

The falling gradient as shown in the first graph in Fig. 14 confirms the theory, and tells us also something of what is happening in the composition of the gas. There is a strong initial fall in the gradient, caused by the increasing proportion of metastables. These soon get saturated, but other excited atomic states with shorter lives keep increasing in number and cause a further fall, which is, however, less steep.

This state of affairs does not continue for ever. If the current is further increased, a point will be reached from which the characteristic becomes positive. This is the "starvation effect," discovered by Langmuir and Mott-Smith. They also found the explanation.

The starvation effect sets in when the ionisation approaches one hundred per cent. If atoms become scarce the gradient will rise for two reasons. The first reason is that it is always more difficult to separate the second electron from an atom

than the first, or in other words the ion-gas has a higher ionisation potential than the normal gas. A second, and even more effective cause of the rising gradient, is that the ions rush to the wall, and when returning as neutral atoms they might become ionised before they reach the inner regions of the column. In other words, the walls act now as a very strong pump and might create an almost evacuated region in the middle of the tube, which, of course, presents a very high resistance to the passage of the current.

This "starvation effect" appears only at very high current densities, and Langmuir and Mott-Smith observed it only in thin quartz capillaries, at very low pressures. The ordinary glass discharge tubes would soften and collapse long before this effect sets in. There is, however, one case of considerable practical importance in which the starvation effect can be observed. This occurs when a mercury arc rectifier is started from cold with a very large current. The vapour pressure of mercury at 20° C. is only about 2 microns, and at 0° C. only 0.2 micron. This small vapour quantity is immediately evacuated by the large current, which interrupts itself, giving rise to very dangerous surges.

A partial starvation effect is probably responsible for the positive characteristic that has been observed in certain mixtures of one gas with a small addition of another more easily ionisable gas. An example is neon, with a small addition of argon, krypton, or xenon. The more easily ionisable gas will be removed towards the outside by the "ionic pump" effect, and this might create a rising characteristic, within certain limits of current intensity.

Another conclusion of the theory is that the gradient must be smaller the larger the tube diameter. This follows from the fact that a small tube has a relatively larger surface, and consumes more electrons and ions for a given plasma. The relation between G and the tube diameter D is approximately hyperbolic, a conclusion which is in very good agreement with experimental results.

(To be concluded next month.)

"Cathode Location in Valves."

(Continued from page 634.)

spacers A which engage the end of the cathode B (exteriorly activated

with the usual oxide coating and containing an insulated heating element) and also engage the ends of the side rods of anode C and grid D. The assembly is mounted upon the stem of the pinch of the envelope, which may be exhausted, sealed off and based in the usual manner.

One end of the tubular cathode B (shown in detail in Figs. 2 and 3) is provided with a short longitudinal groove E terminating in a notch such as a window or cut-out portion F, the height of the notch being approximately equal to the insulating spacer thickness.

The insulating spacer is provided with the usual perforations to receive the ends of the side rods, and an opening for the upper end of the cathode sleeve is so cut out as to leave a short tongue or lug G extending radially into the hole from one side. In assembly the insulating spacer is lowered over the end of the sleeve, permitting the end of the sleeve to slide through its opening with the tongue G travelling along groove E into the notch F. That portion of the sleeve comprising the wall of the groove E is then straightened out so that the bottom portion of the groove wall overlies tongue G and locks the sleeve and spacer together. The edge of the opening extends inward past the outer surface of the sleeve. While the one end of the cathode is positively locked against movement in either an upward or a downward direction the other end of the sleeve is free to slide longitudinally in its spacer.

A modification of the scheme, shown in Fig. 4, comprises a cathode with the groove E terminating in an indentation H. The length of the tongue G may be chosen so as to slide with some friction along groove E so that it will snap into the indentation and lock the cathode and spacer together.

The notch, such as the window F or indentation H, may be formed or blanked out in flat sheet metal, such as nickel, and the metal then be rolled into tubular sleeves with rectangular or round cross section and welded to complete the sleeve. The round sleeve shown in Fig. 5 is provided with a flattened or slightly indented groove or secant J terminating in window F. The spacer opening is made to snugly fit the formed end of the sleeve so that it may be locked in place when the wall at J is pulled out over the spacer.

Radio Clearance Ltd.

63, HIGH HOLBORN,
LONDON, W.C.1

Telephone: HOLborn 4631

FILAMENT TRANSFORMERS, input 200-250 volts, output 4 volts 4 amps., 4 volts 6 amps., 4/11 each.

MAINS TRANSFORMERS. American windings, input 200-250 v. tapped. Output 350-0-350 v. 100 mA., 5 v. 2 amp., 6.3 v. 5 amp., 8/6 each.

G.E.C. MAINS TRANSFORMERS. American windings, 350-0-350 v. 65 mA., 5 v. 2 amp., 6.3 v. 2.5 amp. Suitable for replacements in G.E.C. models, 5/6 each; Auto Transformers, 100-230 v., 6/3 each.

24 mfd. CAN-TYPE ELECTROLYTICS, 450 volts working, 1/6 each.

T.C.C. 8 mfd. Can Wet Type Electrolytics, 450 volts working, 1/3 each.

PRESS BUTTON UNITS with 6 press buttons, ready for wiring into set, with circuit, 6/11 each.

BULGIN 20 ohms wire-wound pots, 1/- each.

STRANDED PUSH BACK WIRE. 1d. per yard, 12 yards, 10d.

CHASSIS MOUNTING VALVE HOLDERS. American, 4, 5, 6 and 7-pin, 4d. each; octal, 6d. each; Loctal, 10d. each. 7-pin English type, 3d. each.

ROTHERMEL Piezo Crystal Speakers, 7½-in. cone. List 55/-, our price, 10/6 each.

CRYSTAL PICK-UP, high-grade American Bronze finish, complete with arm, 21/- each.

POLAR N.S.F. 1 watt resistances, 4d. each, 3/9 doz. All sizes up to 2 meg.

WEARITE MAINS TRANSFORMERS. Made to strict electrical standards, wire-end type, all windings centre tapped, screened primaries, tapped inputs 200-250 volts. Screw adjustment. Type R.C.2. 350-0-350 120 mA., 4 v. 2.5 amp., 4 v. 5 amp., 11/- each. Type R.C.4. 500-0-500 150 mA., 4 v. 2 amp., 4 v. 2 amp., 4 v. 2.5 amp., 4 v. 5.6 amp., 19/6 each. Type R.C.2. Drop-through type, capped. Type R.C.4. Upright mounting type, fully shrouded.

AMERICAN C.T.S. Volume Controls, finest made, divided spindles, length 2½ in., with switch, 2,000, 5,000, 10,000, 25,000, 50,000, 100,000, 2/6 each; less switch, 50,000, 100,000, 500,000, 1/9 each. Wire-wound, 5 watt (less switch), 25,000, 50,000, 2/- each.

BRADLEY WIRE-WOUND VOLUME CONTROLS, with switch, 600,000 ohms, 1/- each.

WEARITE H.F. CHOKES, screened, 1/6 each.

PENTODE SPEECH TRANSFORMERS, 2/- each.

PLESSEY DRY ELECTROLYTICS, can type, 12 mfd. by 6 mfd., 500 volt working, 1/6 each; 12 mfd. by 16 mfd., 350 v. wkg., 1/6 each; 12 mfd. by 8 mfd., 500 v. wkg., 1/6 each; 16 mfd. by 8 mfd., 475 v. wkg., 1/6 each; 6 mfd. by 6 mfd., 500 v. wkg., 1/6 each; 12 mfd., 450 v. wkg., 1/6 each; 8 mfd. by 8 mfd. by 8 mfd., 500 v. wkg., 2/11 each; 16 mfd. by 8 mfd. by 4 mfd., 500 v. wkg., 2/11 each; 12 mfd. by 8 mfd. by 8 mfd., 500 v. wkg., 2/11 each; 16 mfd., 450 v. wkg., 1/3 each; 16 mfd. by 16 mfd., 350 v. wkg., 1/6.

B.I. CARDBOARD ELECTROLYTICS, wire end type, 550 volt working, 8 mfd., 1/9 each. 8 mfd. by 8 mfd., 4-lead type, 2/9 each. 8 mfd. Midget Tubular, wire end, 550 v. wkg., 2/- each. Bias wire end type, 50 mfd., 12 v., 1/3 each; 50 mfd., 50 volt, 1/6 each. Tubular wire end non-inductive paper, all sizes up to 0.1, 5d. each, 4/9 doz.

METAL CASE I-hole fixing Electrolytic Condensers, 550 volt working, 8 mfd., 2/6 each.

STANDARD TELEPHONE HEADPHONES, resistance 2,000 ohms and 4,000 ohms, 6/11 per pair.

VOLUME CONTROLS, 1,000 and 5,000 ohms only, with switch, 1/3 each.

0005 3-GANG TUNING CONDENSER UNITS, with trimmers, 2/11 each.

PLESSEY P.M. 8-in. Moving Coil Speakers, with Pen-trans., 11/6 each; less Pen-trans., 9/6 each.

PLESSEY Energised Speakers, 1,500-ohm field. 8-in., with trans., 7/11 each; 10-in., 2,500 and 1,000-ohm field, with trans., 12/6 each; 6-in., 2,500 and 1,500-ohm fields, 5/11 each.

RUBBER GROMMETS, 4d. per doz.

SPECIAL OFFER. RAYTHEON No. 76 Valves, 2/- each. S.P.D.T. Twist Switches, 1/1 each; D.P.D.T. Twist Switches, 1/3 each.

RAYTHEON First-grade Valves, largest stockists, all types in stock, including Glass Series, Glass Octal Series, Metal Series, Bantam Series, Single-ended Metal Series, and Resistance tubes; all at most competitive prices; send for lists.

All Orders Must Include Sufficient Postage to Cover.
Hours of business: 9 a.m.-6 p.m.; Saturdays, 9 a.m.-1 p.m.

RADIO CLEARANCE LTD.
63, High Holborn, LONDON, W.C.1
Telephone: HOLborn 4631.

Calculation of Reactance

"Phase and Power"

(Continued from page 662).

When we apply a sine wave voltage to a circuit in which there is an inductance, we have a different set of conditions due to the property of the inductance, and it is these conditions which introduce the apparent contradictions which make the theory of A.C. difficult for the student.

Before going further, we can summarise briefly the properties of an inductance.

When a current is flowing through a multi-turn coil† it produces a magnetic field which cuts across the turns themselves and induces in the coil an e.m.f., which is called the "back e.m.f."

The direction of this e.m.f. (i.e., its polarity) is such as to oppose the flow of current through the coil, and its value depends not only on the value of the current but on the *rate of change* of the current. The reason for this can be seen by studying Fig. 4, which shows a sine curve of current variation in an inductance. The magnetic flux (field) is directly proportional to the current, and hence we can draw another curve labelled "flux" which conforms to the current curve. When the current is a maximum the flux is a maximum, and when the current is zero there is no field and the flux curve is at zero.

Now the voltage induced in a coil depends on the rate at which the flux cuts the turns of the coil. This is the principle of the dynamo, in which the coil rotates in the magnetic field. In this case we have the coil stationary and the flux moving past the coil, but the rule still holds. The rate of change of the flux is a maximum when the curve is passing through the zero point, because here the slope of the curve is greatest. At the top of the curve the rate of change is slowest, and as a result the e.m.f. induced in the coil is nearly zero. Accordingly we can draw in another curve to a scale of volts, marked "back e.m.f.," but this curve will be out of phase by 90° . It will also be a sine wave if the flux wave is a sine wave, and lags on the current wave.

The definition of inductance is that it is a measure of the number of volts induced in a coil by a current changing at the rate of one ampere per

Fig. 4.—The phase relationship of the current and voltage in an inductance.

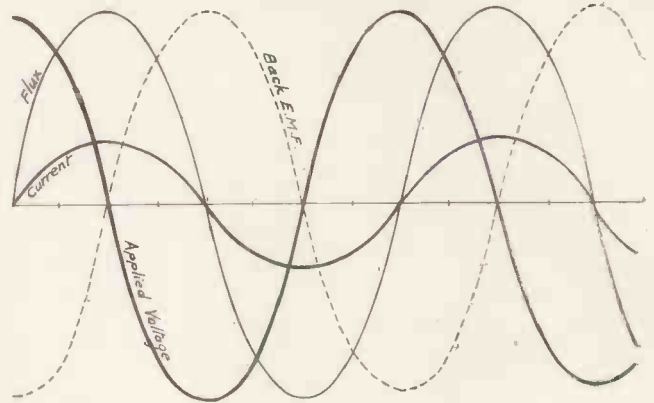

second. Applying this definition to find a formula for the e.m.f. in the coil, we can say that the voltage is proportional to the current "I," the inductance "L" and the number of changes of current per second, which as we have seen, is given by $2\pi f$. The r.m.s. value of the voltage induced is thus: ωLI if I is the r.m.s. current. The value ωL is the *reactance* (not the impedance) of the coil.

So far we have not considered the voltage applied to the coil—in fact, in considering the effects of inductance it is simpler to commence with the current through the coil. The applied voltage has to drive the current through the coil against the back e.m.f. caused by the magnetic field, so it will be of the opposite polarity to the back e.m.f. at every instant. We can therefore draw a final curve in Fig. 4 which is the reverse of the back e.m.f. curve and label it "Applied Voltage."

When the relation of the applied voltage to the current through the coil is studied it will be seen that at any instant the waves differ by 90° , the voltage leading on the current.

More usually, we refer to the current as lagging on the voltage by 90° .

The next step is to draw the power curve, which is done by taking values of voltage and current at various points on the curve multiplying them together and setting the product out to a fresh vertical scale. If the voltage has a negative value while the current is positive the product will be negative and the points must be plotted below the line. The result is shown by the dotted curve of Fig. 5, and it is seen that the power curve is symmetrical about the zero line.

The physical meaning of this is interesting: if we call values of power above the line "positive" and take them to represent power drawn from the mains, we shall have to consider values below the line negative and consider them as representing power flowing in the opposite direction, or returning to the mains. A pure inductance, therefore, draws power on one half-cycle and returns it to the mains on the next half-cycle. The average power consumption is therefore zero over a period of time!

This "something for nothing" argument, however, only holds good for a pure inductance, and in practice the presence of resistance in the circuit will mean that power is always absorbed by a coil.

We can now consider the effect of resistance in the coil or more conveniently, assume that we have a pure inductance in series with a resistance. In calculations involving the resistance of coils it is always more convenient to treat the coil as though there were only inductance present and that the resistance in the coil were a separate component connected in series with it.

A circuit diagram is given in Fig. 6 and the various waves drawn as before. Starting again with the current flowing through the coil and resistance in series, we can draw two voltage waves, one representing the voltage across the inductance V_L and the other that across the resistance V_R . The voltage across the resistance is of course directly proportional to the current and is therefore in phase with it.

The total voltage V across the two is obtained by adding the instantan-

† or a single conductor, for that matter. It is easier or the moment to consider a coil of many turns.

Power Lost in Choke Coils

ous values of the two voltage waves, and we finally get the wave V, which is their sum.

To find the power in the circuit, we proceed as before, multiplying the values of the current and the total voltage together and setting the product out on the same horizontal scale.

taken is 1,000 watts, whereas the actual power consumed is only that in the resistance.

If the resistance is 4 ohms, the power consumed is 400 watts.

Power Factor

The ratio of the actual power consumed in the circuit to the apparent

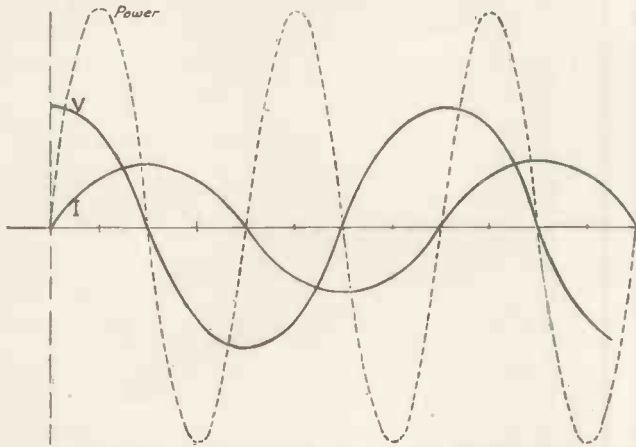
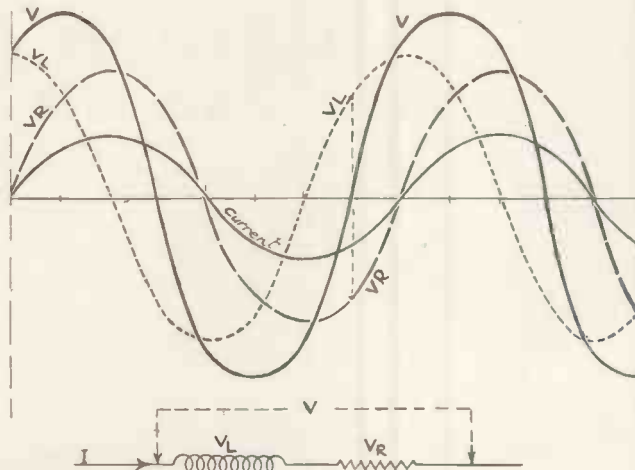

Fig. 5.—Power curve plotted by multiplying values of V and I together from Fig. 4.

This time the area of the power curve above the line is greater than the area below the line, showing that over a period more power is drawn from the mains than is returned to them. The power absorbed is that in the resistance and can be checked by calculating the power curve for

power, as given by the product of the voltage applied and the current, is called the *power factor* of the circuit. In this case the power factor is 400/1,000 or 0.4. Another method of expressing the power factor will be given next month. In the meantime here are some exam-

Fig. 6.—Voltage and current curves for inductance and resistance.



the voltage across the resistance and the current through it, and subtracting this area from the total area. The amount left will be equal on both sides of the line, as we saw in Fig. 5.

The important point to note is that the product of the applied voltage and current does not give the power consumed in the circuit.

In our case, if we have 100 volts applied to the circuit and the current is 10 amperes, the apparent power

ples to show the relation between the voltage and current in a circuit containing inductance and resistance.

A coil has an inductance of 10 henries. Calculate its reactance at 50 and 5,000 cycles.

The reactance is given by ωL (ohms). For 50 cycles ω is 314 and hence the reactance is 3,140 ohms. At 5,000 cycles it will be 100 times as great or 314,000 ohms.

If 100 mA. are passing through the

GALPINS

ELECTRICAL STORES

75, LEE HIGH ROAD, LEWISHAM, LONDON, S.E.13

Telephone : LEE GREEN 5240

Terms :

Cash with Order or C.O.D. Charges extra.

ALL GOODS SENT ON THREE DAYS' APPROVAL AGAINST CASH

CROMPTON DYNAMO, 4-pole shunt wound, 1,750 r.p.m. 100 volts 10 amps., 70/-. Ditto, 50/75 volts 15 amps., 75/-. Carriage forward.

MACKIE MOTOR GENERATOR, 220 volts 3.35 amps. D.C. input, 10 volts 30 amps. D.C. output, 37/6. C/F.

CROMPTON DYNAMOS, 4-pole shunt wound, 1,750 r.p.m. 22 volts 10 amps., 70/-. Ditto, 50/75 volts 25 amps., 90/-. C/F.

NEWTON MOTOR GENERATOR, 220 volts D.C. to 16 volts 10 amps. D.C., 30/-. C/F.

MACKIE MOTOR GENERATOR, 220 volts D.C. to 400 volts 170 m/A. and 15 volts 8 amps. D.C. Three pieces coupled together on bedplate, 55/-. C/F.

CROMPTON MOTOR GENERATOR, 220 volts D.C. to 500/750 volts 200 m/A. D.C., 40/-. C/F.

SMALL MOTORS. Beckenham Motor Generators, 220 volts D.C. to 500 volts 300 m/A. and 12 volts 12 amps. All three coupled together on slide rails. 35/- each. C/F.

E.C.C. SHUNT WOUND DYNAMO, 100 volts 50 amps., 1,500 r.p.m., 26 10s. C/F.

MACKIE ALTERNATOR, 120 volts D.C. input, 65 volts 1 ph. 150 cycles 1/2 kW. output. Vertical type, 45/-. C/F.

C.A.V. SHUNT WOUND DYNAMOS, 25 volts 8 amps., 1,750 r.p.m., 32/6. C/F.

G.E.C. SHUNT WOUND DYNAMOS, 50 volts 6 amps., 1,500 r.p.m., 30/-. C/F.

CROMPTON SHUNT WOUND DYNAMO, 100 volts. 4 amps., 1,750 r.p.m., 35/-. C/F.

HIGH VOLTAGE TRANSFORMERS for Television, Neon etc. 200/240 v. 50 cy. 1 ph. primary, 5,000 and 7,000 volts secondary, enclosed in petroleum jelly. Size: 5 1/2 in. x 4 1/2 in. x 4 1/2 in., 7/6 each, post 1/-. Ditto, Skeleton type, 5/6, post 9d. All brand new.

EVERSHED EX-R.A.F. HAND-DRIVEN GENERATOR, in new condition, 800 volts 30 m/A. and 6 volts 2 1/2 amps. D.C. Useful as megger genies and all test work. 20/- each, post 1/6.

EX-G.P.O. GLASS TOP RELAYS, Type B. Useful as Keying Relays, 5/- each, post 6d. Also a few only that need points, which are easily fitted, 2/6 each. P/F.

T.C.C. 2,000 MF. ELECTROLYTIC CONDENSERS, 50-volt working (brand new), 5/- each, post 6d.

STANDARD TELEPHONE BELL WIRE, all brand new. 150-yd. coils, twin 22 gauge, 4/-, post 9d.; 250-yd. coils, single 16 gauge, 4/-, post 1/-. 300-yd. coil, single 22 gauge. 3/-, post 6d.

P1 STANDARD TELEPHONE PUSH-BACK CONNECTING WIRE (new), 220-yard coils, 12/6, post 1/-.

STANDARD TELEPHONE MAINS TRANSFORMERS, input 200/250 volts, output 250/0/250 volts 200 m/A., 3 x 4 volt windings and a 50-volt winding, 12/6 each.

MACKIE DOUBLE WOUND EX-R.A.F. GENERATORS, 1,200 volts 100 m/A. and 10 volts 4 amps., 3,000 r.p.m., 12/6 each. Carriage 1/6.

MUIRHEAD 1 MF. CONDENSERS, 1,000-volt working, 1/- each, post 6d.; or three for 2/6, post 1/-. Philips 1 mf., 3,000-volt working, 5/-. T.C.C. 4 mf., 3,000-volt working, 9/6 each. Standard Telephone 1 mf., 400-volt working, 4d. each, or in lots of 100 for 12/6, post 1/6.

ERNEST TURNER & WESTON 2-in. DIAL MOVING COIL MILLIAMMETERS, B.S. first grade, 0 to 5 and 0 to 50, 17/6 each.

X-RAY TRANSFORMERS, by well-known makers, all fully guaranteed. 50 cycle mains, 40,000 volts, 10 m/A., 25; 68,000 volts, 20 m/A., 27 10s.; 100,000 volts, 30 m/A., 210 10s. All carriage forward.

MULTI CONTACT RELAYS, EX-G.P.O., as used in automatic exchange, condition as new, small size, suitable for automatic tuning for press button control, heavy platinumoid contacts; 2/6, post 3d.; 2 for 4/-. post 6d.; 3 for 6/-. post 6d.

ELECTROLYTIC CONDENSERS, 8 mf., 350 v.; 4 mf., 250 v.; 6 mf., 450 v.; 1/3 each, post 3d.; 8 x 8 mf., 450 v., 2/-; 8 x 16 mf., 450 v., 2/- and 8 x 8 x 2 mf., 450 v., 2/- each, post 3d.

AUTO TRANSFORMERS, 500 watt, 25/-; 750 watt, 32/-; 1,000 watt, 37/6 and 1,500 watt, 50/-; guaranteed 12 months.

coil, what is the voltage drop, assuming there is no resistance? At 50 cycles, the voltage will be ωLI , or $3,140 \times 0.1 = 314$ volts. At 5,000 cycles the voltage drop will be 100 times as great.

If the coil has a resistance of 100 ohms, the voltage drop produced by a current of 100 mA. will be 10 volts. This does not mean that the total voltage drop will be $314 + 10$, as the two are not in phase. (Refer to Fig. 6.) The power lost in the coil will be 10×0.1 or 1 watt.

Now, work out the voltages and power in a coil of 50 henries at 50 cycles passing a current of 50 mA. and having a resistance of 100 ohms.

Answers to last month's problems.

(1) The drawing of the curve should follow the lines of Fig. 1, the maximum value being 25 volts. Other points on the curve should check as follows: At 30° $12\frac{1}{2}$ volts, at 45° 17.5 volts, at 60° 21.5 volts.

(2) The values are also shown in Fig. 1 of this month's article.

(3) 3 cms. deflection requires a deflecting voltage of 30×2 or 60 volts. This is the peak-peak value, and the peak value of the wave is therefore 30 volts. The r.m.s. value is 21 volts approximately.

An Improved D.C. Restoring Circuit

IT is frequently necessary to restore the D.C. component of a television signal which has been passed through A.C. couplings and the circuit shown in the attached diagram, is described in British Patent Specification 402,000, which has been developed in the E.M.I. Laboratories, has been found very suitable for this purpose. The circuit is a variation of the so-

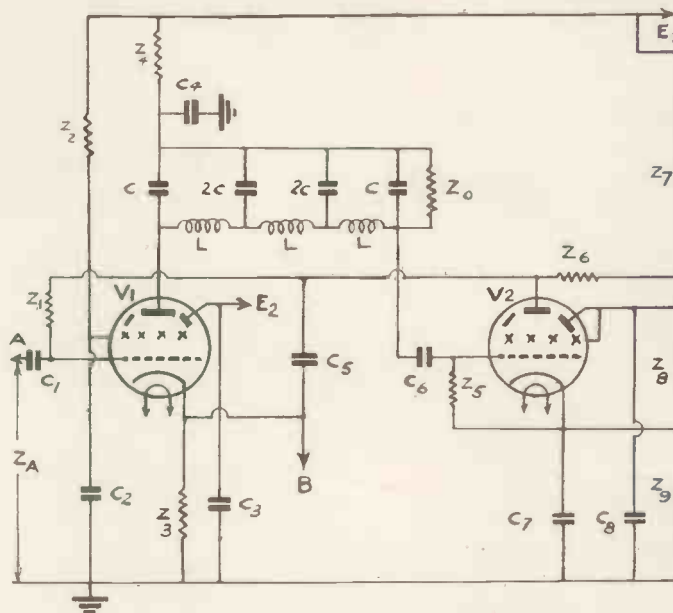

A modified D.C. restoring circuit recently developed in the E.M.I. laboratories.

called "clamp" D.C. circuit which is described in British Patent Specification 402,000, which has been developed in the (Continued opposite)

Amateur Radio in Wartime!

IN days of Peace the Amateur Radio Movement was one of the most important of all scientific hobbies. With the coming of war many hundreds of the best radio amateurs in Great Britain answered the Call of Service. Those remaining behind are pledged to keep alive the "Ham Spirit" created during the past two decades.

The Incorporated Radio Society will carry on the work commenced in 1913 of safeguarding the interests of its members (and incidentally non-members as well).

The Society's Journal, *The T. & R. Bulletin*, will continue monthly publication, thereby bringing to members the latest news of technical developments. Additionally, the Society will act as an important link in keeping together the whole of the British Amateur Radio fraternity.

NEW MEMBERS are cordially welcomed.

Reduced War Time Subscription Rates are now in force.

British Isles	15/- per annum
Overseas	12/6 per annum
British Isles (Service Members)	10/- per annum

IMPORTANT NOTICE.

"THE AMATEUR RADIO HANDBOOK" (296 pages) which has recently been reprinted is the only all-British publication dealing fully with every aspect of Amateur Experimental work. An ideal text book for the Wireless Operator or Signalman. Get your copy to-day.

PRICE 3/- POST FREE.

All communications to:—

The Secretary-Editor,
RADIO SOCIETY OF GREAT BRITAIN
 16, Ashridge Gardens, London, N.13
 Telephone, Palmers Green 3255

THE TELEVISION SOCIETY AND THE WAR

Now that the war has put a temporary stop to television developments, it is more than ever necessary that the work of the Society should continue.

At its new headquarters at 17, Featherstone Buildings, Holborn, a reference library of books and data is available to members, and a museum of historic apparatus is in course of assembly.

This will form a valuable record of work done in the television field, and will enable all interested in the science to keep track of the progress made until normal working is resumed.

Television engineers are invited to register with the Society, who will be pleased to put them in touch with fellow workers and keep them informed through the medium of the Journal.

Full particulars of membership qualifications may be had from the Hon. General Secretary:—J. J. Denton, 17, Anerley Station Road, London, S.E.20.

THE TELEVISION SOCIETY

(Founded 1927)

President: Sir AMBROSE FLEMING, M.A., D.Sc., F.R.S.