

# ELECTRONICS WORLD

SEPTEMBER 2004 £3.25

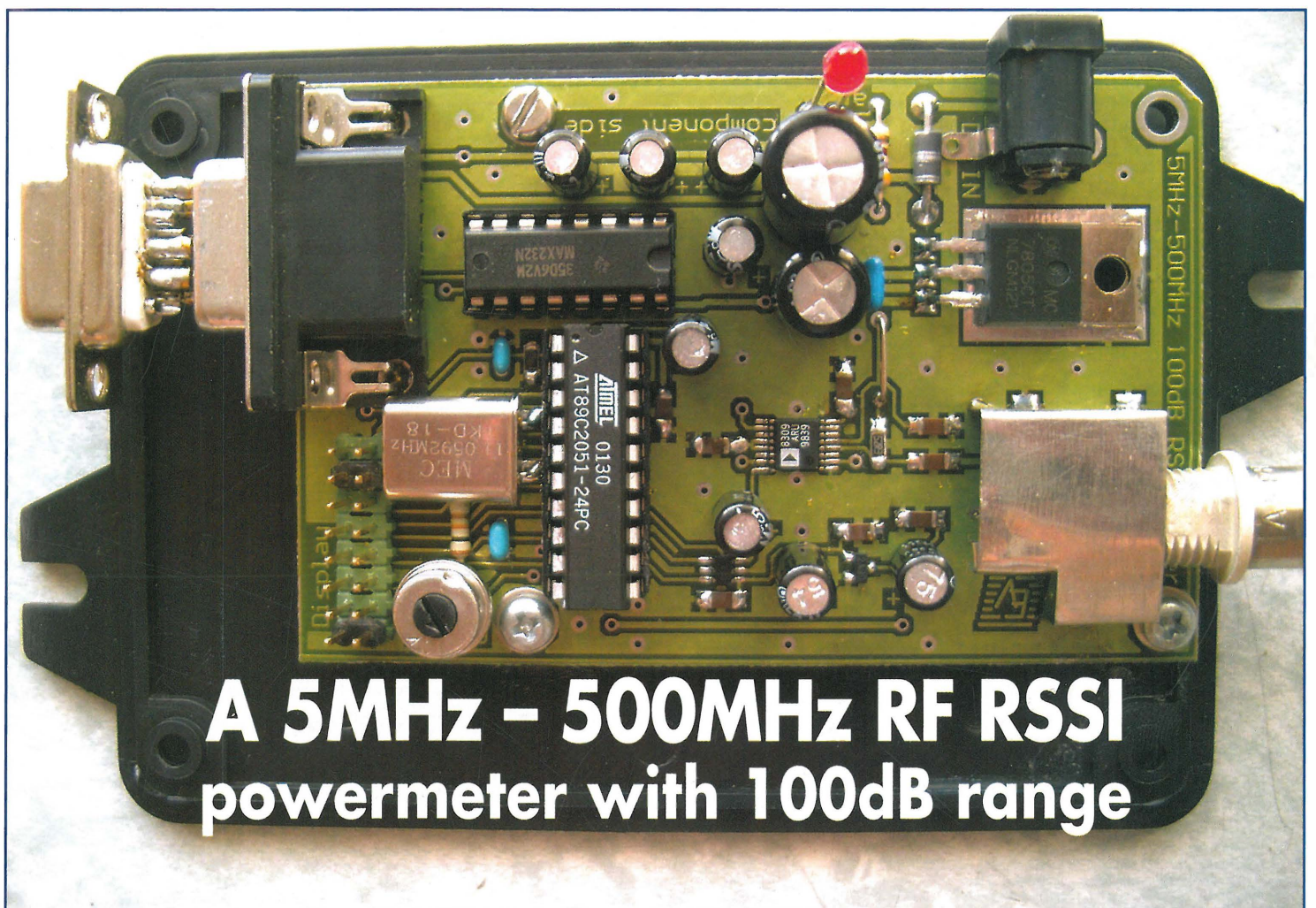

**A 5MHz - 500MHz RF RSSI  
powermeter with 100dB range**

**Making microcontroller RAM non-volatile**

**TV 'pong' game**

**Linear phase shifter**

**Class-A imagineering IV**

## Circuit Ideas

- Telephone line monitor with extremely high impedance
- All-pass filter based on current-feedback amplification
- Traffic light controller
- Fly-by-wire integrity checker



# PROTEUS

## The Complete Electronics Design System

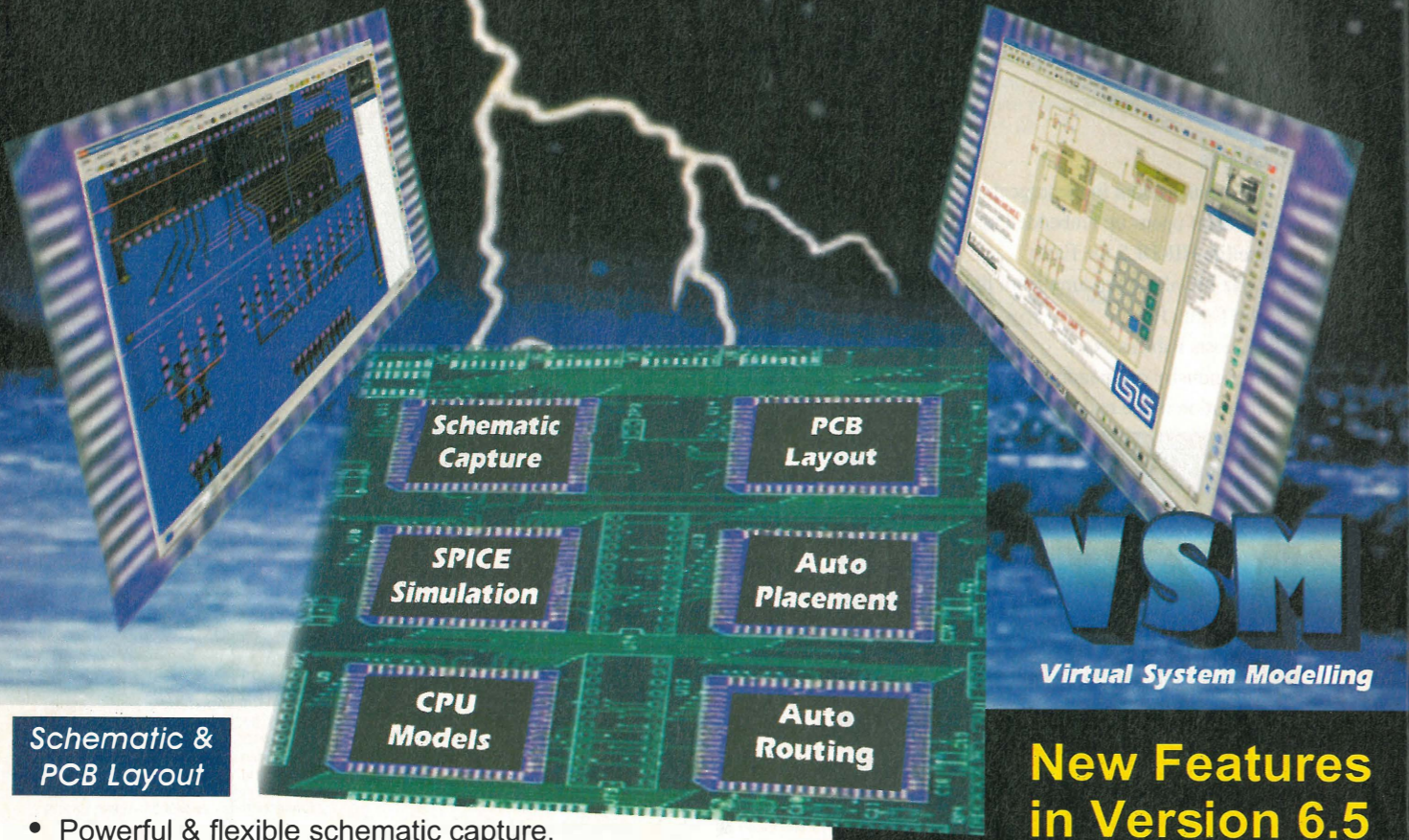

### Schematic & PCB Layout

- Powerful & flexible schematic capture.
- Auto-component placement and rip-up/retry PCB routing.
- Polygonal gridless ground planes.
- Libraries of over 8000 schematic and 1000 PCB parts.
- Bill of materials, DRC reports and much more.

### Mixed Mode SPICE Circuit Simulation

- Berkeley SPICE3F5 simulator with custom extensions for true mixed mode and interactive simulation.
- 6 virtual instruments and 14 graph based analysis types.
- 6000 models including TTL, CMOS and PLD digital parts.
- Fully compatible with manufacturers' SPICE models.

### Proteus VSM - Co-simulation and debugging for popular Micro-controllers

- Supports PIC, AVR, 8051, and BASIC STAMP micro-controllers.
- Co-simulate target firmware with your hardware design.
- Includes interactive peripheral models for LED and LCD displays, switches, keypads, virtual terminal and much, much more.
- Compatible with popular compilers and assemblers from Microchip, Crownhill, IAR, Keil, and others.

**labcenter**  
Electronics  
53-55 Main Street, Grassington. BD23 5AA

Tel: 01756 753440  
Fax: 01756 752857  
Contact us for  
**Free Demo CD**

## New Features in Version 6.5

- Textual library part search.
- User defined keyboard map.
- CAD/CAM output to ZIP file.
- Bitmap import function.
- Truetype fonts on PCBs.
- Enhanced printer output.

Call Now for Upgrade Pricing



[www.labcenter.co.uk](http://www.labcenter.co.uk)  
[info@labcenter.co.uk](mailto:info@labcenter.co.uk)

**EDITOR**  
Phil Reed  
[p.reed@highburybiz.com](mailto:p.reed@highburybiz.com)

**CONSULTANT**  
Ian Hickman

**CONTRIBUTING EDITOR**  
Martin Eccles

**PRODUCTION EDITOR/DESIGNER**  
Jane Massey  
[J.Massey@highburybiz.com](mailto:J.Massey@highburybiz.com)

**EDITORIAL E-MAILS**  
[EWeditor@highburybiz.com](mailto:EWeditor@highburybiz.com)

**EDITORIAL ADMINISTRATION**  
Caroline Fisher  
01322 611274  
[EWadmin@highburybiz.com](mailto:EWadmin@highburybiz.com)

**GROUP SALES EXECUTIVE**  
Steve Morley  
01322 611254  
[s.morley@highburybiz.com](mailto:s.morley@highburybiz.com)

**PRODUCTION EXECUTIVE**  
Dean Turner  
[d.turner@highburybiz.com](mailto:d.turner@highburybiz.com)  
01322 611206

**CLASSIFIED FAX**  
01322 616376

**MANAGING EDITOR**  
Bill Evett

**PUBLISHING DIRECTOR**  
Tony Greville

**BUSINESS SECTOR MANAGER**  
Mark Skelton

**ISSN 0959-8332**

**SUBSCRIPTION QUERIES**  
Tel (0) 1353 654431

Disclaimer  
We work hard to ensure that the information presented in *Electronics World* is accurate. However, *Electronics World's* publisher - Highbury Business - will not take responsibility for any injury or loss of earnings that may result from applying information presented in the magazine. It is your responsibility to familiarise yourself with the laws relating to dealing with your customers and suppliers, and with safety practices relating to working with electrical/electronic circuitry - particularly as regards electric shock, fire hazards and explosions.

**Electronics World** is published monthly by Highbury Business, Media House, Azalea Drive, Swanley, Kent, BR8 8HU

Highbury Business is a trading name of Highbury Business Communications Limited, a subsidiary of Highbury House Communications PLC. Registered in England. Registered Number 4189911. Registered Office: The Publishing House, 1-3 Highbury Station Road, Islington, London N1 1SE

## Where is our heritage?

*Electronics World* reports regularly on modern developments and frequently carries articles using up to date technology. From time to time it relapses (and as a personal view not often enough) into the past and publishes fascinating articles about our industry.

If wireless had been two hundred years old, along with canals, railways, water mills and windmills, together with a few stately homes belonging to (relatively) impoverished aristocrats, the national quango responsible for our heritage would have endeavoured to preserve some of our historic relics.

As it is, not one of the several radio stations around our coasts serving our Merchant Marine has been preserved. Admittedly some of the buildings reflected the robust architectural styles of the one-time Ministry of Works, but the occasional one - Anglesey Coast Station springs to mind - departed from the tradition. What of the early Marconi high-powered stations and their complementary receiving sites? The buildings at Waen Fawr, near Caernarfon are still standing (from whence the first signals to reach Australia were emitted.)

The apparatus there went from spark, to alternator and then to valves, none of the equipment remains. But have the buildings been listed? The buildings of the receiving station, not far away at Towyn (formerly accommodation for the staff) now proudly display their title 'Marconi Bungalows' - but they will not last forever unless they are preserved. The buildings at Leaffield, in Oxfordshire, built to accommodate the UK end of the 'Empire Chain', were standing when I last saw them some twenty-five years ago. They didn't come into their own as a transmitting station until about 1920, but the aerial was used during World War I for interception purposes. Its original buildings mirror the Marconi style of Caernarfon. What remains of the short-wave Beam Stations provided by Marconi for the

Post-Office? Several of the buildings still exist but what of the equipment?

There is part of one of the SWB1 transmitters in the South Kensington Science Museum! Is that the only memory of a great venture? The equipments in the large HF stations at Rugby, Leaffield and Ongar have disappeared without trace as have the receiving stations at Somerton, Bearley and Baldock, although the latter still functions as the centre for the Radio Agency. The high-powered VLF stations at Rugby and Criggon, which were of primary importance during World War II and the subsequent 'Cold War' are now no more. Criggon, which provided communications during the action against the Bismark, was dismantled with indecent haste when it was closed down in March 2003 and recently eight of the Rugby masts have been demolished after contributing to the Midlands landscape for virtually eighty years. So much for BT's interest in our heritage.

They couldn't keep their museum at Blackfriars intact and then tried to make a virtue of dissembling its contents around the country to non-specialist museums! As if to rub salt into the wounds, English Heritage have recently graded examples of latter-day communications, namely Goonhilly's first dish and building, the London BT Tower and now the Bawdsey radar transmitter building. True, these are important buildings in the history of wireless communications, but why have the previous 100 years been so ignored? Communications throughout the twentieth century have brought the peoples of the world closer together and have contributed in no small way to the improvement in their lifestyles. Surely if Sweden can keep a radio alternator station in working order together with a broadcaster at Motala are we so impoverished that we cannot do likewise before it is too late?

Stan Brown M.B.E. C.Eng. MIEE

**Newstrade:** Distributed by Seymour Distribution Ltd, 86 Newman St, London W1T 3EX. **Subscriptions:** Highbury Fulfillment Services, Link House, 8 Bartholomew's Walk, Ely Cambridge, CB7 4ZD. Telephone 01353 654431. Please notify change of address.

**Subscription rates**  
1 year UK £38.95 O/S £64.50  
US\$106.40 Euro 93.52

**USA mailing agents:** Mercury Airfreight International Ltd Inc, 10[b] Englehard Ave, Avenel NJ 07001. Periodicals Postage Paid at Rahway NJ Postmaster. Send address changes to above.

**Printed by** Polestar (Colchester) Ltd,

**Origination** Impress Rebro by Design Ltd A1 Parkway, Southgate Way, Orton Southgate, Peterborough, PE2 6YN



## Zinc beats lithium in rechargeable battery

Intel has leant its weight to a new battery technology by tying up with Zinc Matrix Power of Santa Barbara, California to "develop a new battery technology for laptop computers that could result in laptop run times of up to ten hours", said ZMP.

The two firms will work together to develop aspects of the technology including battery packaging, charging circuits and fuel gauges. The results will be previewed in this month at Intel's developer forum and commercial production is expected in 2006, said ZMP.

The basic battery technology is similar to that in common disposable alkaline manganese batteries and in one form, claims the firm, "it has demonstrated about two times the energy to volume of today's lithium-based laptop batteries in lab tests".

Zinc metal has two characteristics which make it extremely difficult to recharge. Firstly zinc oxide is highly soluble in alkaline electrolyte, and secondly zinc recharges at about the same voltage which break water down into hydrogen and oxygen.

Together these have prevented zinc-based rechargeable having a life of more than a few cycles.

Zinc oxide is formed during discharge and, because it is soluble, it dissolves in the electrolyte and moves around in the battery. On recharge, the zinc re-forms anywhere on the anode, typically in low surface area lumps which cannot deliver high current like the high surface area

powder batteries are made with.

To cure this tendency to plate-out anywhere, maintaining constant surface area and therefore allow the battery to operate consistently from cycle to cycle, the anode material must reform exactly where it was on the last cycle. ZMP does this by containing its zinc granules in a proprietary polymer matrix.

This matrix is permeable to the hydroxide ions which need to move during charge and discharge, but blocks zinc oxide from leaving the immediate vicinity of each zinc grain. "Each zinc granule is locked in place such that the surface area does not significantly change over 100 charge/discharge cycles or more," said the firm.

The other issue, zinc recharging at a voltage that splits water into hydrogen and oxygen, causes hydrogen to be liberated and the battery gradually dries out - oxygen is not an issue because it recombines with freshly-deposited zinc, forming zinc oxide at the expense of somewhat reduced charging efficiency.

Heavy metals used to be added to recombine the hydrogen, but the ones that work are environmentally harmful. "New low toxicity additives have been found which work adequately in non-rechargeable batteries, but they don't work perfectly on recharging," said ZMP. This leads to slight gassing.

Other water based battery chemistries solved the hydrogen problem by recombining it with



**Zinc Matrix Technology at a Glance - various cathodes.**

Cell voltage	1.5V
Capacity	up to 240Wh/kg and over 600Wh/liter
Peak delivery	up to 5kW/kg and 10kW/litre
Life	100 cycles minimum
Self-discharge	"low"
Float charge	possible
Cell thickness	3mm minimum
Safety	no lithium water based chemistry zero pressure packaging

oxides on the cathode to reform water.

Unfortunately, the only block zinc oxide also block hydrogen, "making a sealed recombinant rechargeable zinc battery a challenge".

ZMP's polymers however, are both hydrogen permeable and impermeable to zinc oxide in solution, allowing the hydrogen to get to the cathode and recombine, while blocking zinc migration.

The ZMP zinc-polymer anode can be combined with most cathodes "including: manganese dioxide, nickel hydroxide, air cathodes, mono and divalent

silver oxide and singular or mixed oxides of Cu, Cr, V, Co", it said.

Of these, the cheapest is the same alkaline zinc manganese dioxide chemistry used in domestic 'alkaline' cells.

At the high-performance end, a zinc-silver chemistry leads to ZMP's claim of double the capacity of Liion cells.

In the pipeline, experimental 'super oxide' cells - using proprietary oxidation resistant cathode barriers and a cathode matrix which immobilizes soluble cathode components - show potential to operate above 2.0V/cell and further improve capacity.

## Microsoft opens up embedded operating system

Licensees of Microsoft's Windows CE operating system are now able to access the source code and produce their own versions of the operating system.

The software giant has extended its open source arrangement with version five of the embedded operating system,

which opens up some 2.5 million lines of code to developers.

Access is available to the kernel of the OS, the graphical user interfaces, file system, device drivers and the Web server.

Moreover, developers are under no obligation to share their modification with Microsoft or

any other firm.

"We believe that the ability to ship commercial derivatives, with no obligation to share customisations, will greatly appeal to device makers - all of whom want to maintain the rights to their competitive advantage," said Ya-Qin Zhang,

of the firm's mobile and embedded devices division.

The firm has a unified toolkit for developing Windows CE operating systems priced at \$995. A free 120-day trial version can be downloaded from the firm's website. <http://msdn.microsoft.com/embedded>

## Satellite HIRDLS the Earth

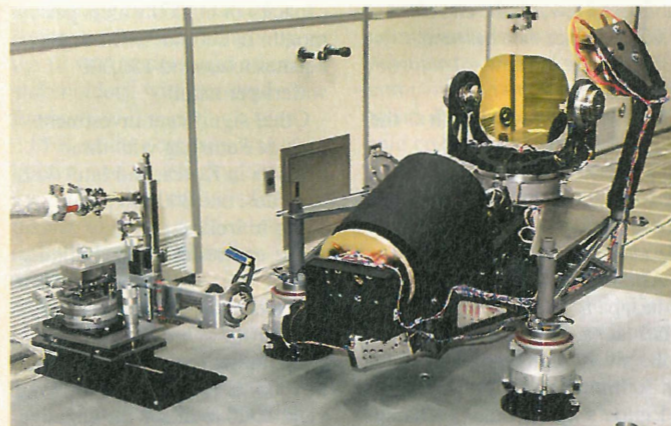

NASA's latest mission - a satellite to probe the Earth's atmosphere for pollutants - is using an instrument designed and built in the UK.

The Aura satellite is the third of the so-called A-Train, which will pass over the planet looking at the ground, the oceans and now the atmosphere.

Aura's brief is, from 700km up, to look at air quality and climate change. It should be able to answer the question of whether the ozone layer is regenerating.

A key part of the mission is

HIRDLS - High Resolution Dynamic Limb Sounder, which will measure ten key chemicals - including ozone - from the top of the clouds to the mesosphere (as high as 70km).

"Information derived by HIRDLS will be used to assess the impact of a range of natural and man-made activities, including air travel, volcanic eruptions and the movement and concentration of greenhouse gases on a daily basis," said Colin Hicks, director general of the British National Space Centre.

## 5GHz InGaP power amp from the Fens

Cambridgeshire design consultancy Plextek has revealed a 4.9 to 6GHz power amplifier IC with a controllable linearity/power tradeoff.

Designed as a technology demonstrator, the amplifier incorporates an on-chip active bias arrangement that dynamically sets bias to give low quiescent current with high linearity when backed-off from compression - IP3 point is over +37dBm at +18dBm out, or good efficiency when saturated with 0.5W out.

This gives the amplifier two basic modes. "For low-power applications like 802.11a which have complex modulation schemes it will operate linearly

on about 100mA. For higher power simply-modulated schemes, like 0.5W FSK for cordless phones, it operates saturated where current is higher, but so is efficiency," said Plextek director Liam Devlin.

An off-chip output matching network sets the exact frequency/power tradeoff.

The device is made using an InGaP heterojunction bipolar transistor (HBT) process from US foundry GCS and can be used for a number of applications including the US UNII standard, 802.11a, HiperLAN2, Japanese WLAN and cordless telephony. [www.plextek.com](http://www.plextek.com)

HIRDLS contains 21 photoconductive HgCdTe detectors, each cooled to 65K, and measuring wavelengths between 6.12mm and 17.76mm. The £20m instrument can measure ten chemicals - including ozone, water, methane, nitrous compounds and various CFCs.

"HIRDLS will give us a much better picture of what is happening in the upper atmosphere," said John Barnett, the joint principal investigator at the University of Oxford.

"Computer models of the atmosphere show features that we are incapable of observing at present. We need to understand in more detail how the atmosphere works and whether these models are right or need changing, because we rely on them for predictions of climate change."

UK contributors to HIRDLS include the Rutherford Appleton Laboratory - optical design and building the power supplies; EADS Astrium - thermal design and main structure and sun shield; Reading University - infra-red filters; and BAE Systems in Edinburgh - gyroscopes.



*Five French students from Heriot-Watt University in Edinburgh have won the Alba Centre Design Award for their Martian rock sorter. The technology students designed and built a computer operated demonstrator as part of their third year course work.*



*Hard disk driver maker Seagate has once again sponsored the Young Innovators competition in Northern Ireland. The Belfast event awards youngsters developing technology-based systems.*



*Toshiba has developed a miniature fuel cell that can output up to 100mW for handheld consumer devices.*

*The direct methanol cell measures 22x56x4.5mm and weighs 8.5grams. Using just 2cc of fuel it can power an MP3 player for 20 hours, claimed the firm.*

*The cell uses a passive technique, with almost pure methanol passed directly into the cell. The firm said it can avoid methanol crossover, which sees fuel combine with oxygen direct, and hence producing no power.*

## IEE hosts Fabless execs

The Institution of Electrical Engineers is joining up with the Fabless Semiconductor Association to host an executive forum in September.

The forum will examine tensions in the chip industry, especially those fuelled by China's plans to increase manufacturing capacity.

"The challenges associated with the drive to advanced semiconductor process technologies, coupled with the huge volumes enabled by 300mm fabs, has induced massive changes within the semiconductor industry," said Rick Tsai, president of TSMC who will speak at the event.

Other speakers include Sir Robin Saxby, chairman of ARM; Jen-Hsun Huang, president and CEO of Nvidia; Dr Sanjay Jha, president of Qualcomm CDMA Technologies; and Pascal Ronde, a v-p at Agilent Technologies.

Panel sessions will examine how fabless companies and integrated device manufacturers (IDMs) manage their relationships with foundries. Saxby said: "The continuing development of deep sub-micron technology combined with increasing emphasis on designs incorporating software and standards makes global partnering ever more critical to success."

There will also be a discussion on the future of the industry, as the foundries seek to meet rising demand against the backdrop of boom-to-bust industry cycles.

**The IEE/FSA Semiconductor Executive Forum is held on September 7 and 8 at: IEE Savoy Place, London.**

<http://conferences.iee.org.uk/semiconductor>

## Chip industry on spending spree

The chip industry's propensity for self destruction is showing no signs of changing, as this year sees record levels of investment in new fab capacity.

In the second quarter of 2004 work began on 15 new projects that will have a total capacity of 200,000 wafers (200mm) per month.

Analyst firm Strategic Marketing Associates (SMA) found that the construction set a record both in terms of the size and value of the fabs, with a combined cost of \$18.4bn. This, said SMA, equals the investment through the whole of 2003.

Like all previous cycles in the semiconductor industry, the building of too many new plants during the upturn will lead to over-capacity and hence bring on, or exacerbate, the next downturn.

The current rush to build new fabs began towards the end of 2003, and since then has seen \$35bn pledged to new construction.

"While this is not as high as the \$58bn the industry started construction on in the last boom of 1999-2001, the rate of today's boom is much higher," said George Burns, president of SMA.

Almost half of the construction is in Japan, where Elpida, Fujitsu, Matsushita, NEC and Toshiba are collectively spending \$8.4bn, all on 300mm fabs.

Elpida's DRAM fab is notable as the biggest single investment to date on a semiconductor plant, with a projected end cost of up to \$4.5bn.

Production is scheduled to start later next year using 0.11µm and 85 nm design rules. The firm

said it would eventually have a capacity of 60,000 wafers per month. In 200mm terms that equates to around 150,000 wafers per month.

Other significant investments include Samsung with three projects in Korea, and Intel with two fabs, one 300mm plant being in Ireland.

The end result of this building will be over-supply of ICs. Most analysts agree that this year will see growth of around 30 per cent, falling to perhaps half that in 2005. However, the following year, 2006, will see the negative growth.

The only way to avoid the over-capacity is to invest in the downturn, ready for the next boom, but only the top two or three firms can afford to take this approach.

## Simulation in the real world

A novel scheme for tracking the signal integrity and timing inside ICs has been developed by NEC.

The Japanese firm is embedding special circuits in its chips that monitor the devices operating in the field. Devices that are networked can report back on their internal performance.

"As a result of this scheme, needless design margin can be reduced, and a next-generation feedback capable LSI development scheme based on

precise degradation prediction is realised," said Masao Fukuma, v-p of NEC's R&D unit.

The technique will address the increasing inaccuracy of chip development software and the corresponding rise in the number of re-spins required to get a chip design correct.

The traditional approach would be to design extra margin into the timing of the signals on the chip.

"Degradation of the signal quality in actual LSI cannot be fully grasped by conventional

LSI development schemes which depend on CAD tools that use signal integrity models obtained from software simulation," said the firm.

Measuring the actual signal integrity means ICs can be designed with smaller margins and fewer prototypes should be needed. This, said Fukuma, "achieves shorter development time, and faster time to market".

NEC said it has already begun using the technology in some of its products.

This new LSI development scheme was enabled by the development of the following two main technologies:

- (1) Composed of input and output digital signals formed through the input and output of signal waveform analogue information as digital signal timing information, technology which enables the collection and analysis of the amount of quality deterioration within the chip signal waveform, even if the LSI is embedded in an electronic device that is actually running a customer's program.
- (2) Technology that can precisely measure the amount of quality deterioration, even if the high frequency component of the high-speed digital signal is contained within the signal, through newly developed comparator circuits operated under a bias condition with the highest sensitivity response.

## Founder buy-out saves UK display technology

The assets of UK display technology firm Printable Field Emitters have been bought by the firms founders, and other stakeholders, with personal funds.

PFE, as the company was known, was developing second-generation field emitters for display use and produced the technology demonstrators pictured in April, just before the firm was placed into the hands of administrators, for reasons that have not become clear.

Field emission displays (FEDs) produce the same high-quality images as CRTs, but are thinner than plasma screens.

Second-generation FEDs avoid the micron-level lithography needed by first-generation FEDs, which can only be performed on a few square centimetres, and can therefore be made over a metre across. PFE was aiming to licence its intellectual property

to TV screen makers.

When the firm went into administration, "we were quite advanced with an Asian company and starting the technology transfer process", said co-founder Richard Tuck. "The intention is to continue this and start activities in the UK to support that."

Although the new company will be called FEDCO (Field Emission Display Company), it will continue to trade under the Printable Field Emitters banner.

FEDCO will be a smaller operation than the old PFE, working mainly on the materials side of display development and with no need to make costly prototypes as PFE successfully demonstrated the technology, said Tuck.

If all goes well, expect to see early partner-made displays in "six to nine months, probably closer to nine," said Tuck.

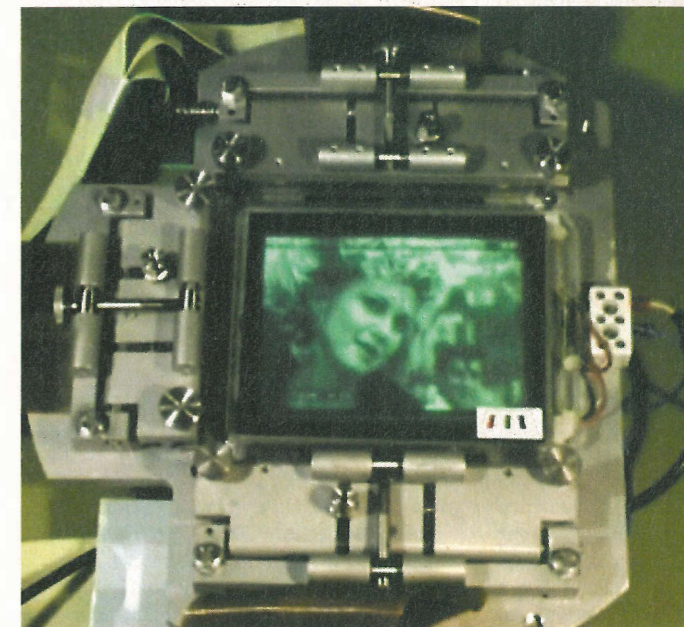

PFE proved its technology worked, with displays limited only by its rudimentary lab-based manufacturing equipment, it claimed. Now FEDCO aims to take it to production

## Blind see through tongue-based display

An electronic array mimicking a 100 year-old technique for communicating with the blind by touching their tongue has revealed new knowledge on the brain's ability to learn.

The array, developed with its electronics at the University of Wisconsin, has a 12x12 matrix of electrodes and is also held against the blind person's tongue.

Earlier research showed that, following a little as a few minutes use, the subject can 'see' simple images formed by the 144 available pixels.

The question has been, are these images seen by the brain's visual processing system, or

somewhere else.

Neuropsychologist Maurice Ptito of Université de Montréal, who is working with colleagues in Denmark and the US, put people in a brain scanner and fed them pictures through the tongue display unit, or TDU.

"The images are articulated in the visual cortex," Ptito told *Electronics World*.

"In a congenitally blind person, the cortex has never been used before. This proves the brain can do sensory substitution and the tongue can really act as a portal to carry information to the visual cortex."

This disproves a theory that proposed the visually cortex

gradually fails if it is not used. "The cortex is alive and being recruited," said Ptito, and this visual perception appears to be perceived in the same way as sighted people experience vision. "Subjects say that they see the stimulus outside them," he said.

"These people have never seen, they have no visual repertoire."

Following this work, Ptito and collaborators are working on a wireless TDU with electrodes built into something resembling a top denture and a small camera, which could eventually be fitted into a false eye, said Ptito.

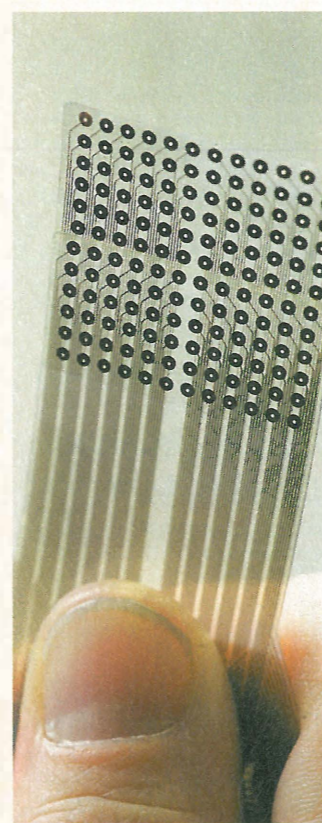

Three years ago the University of Wisconsin produced this, an electrode array for presenting images to a person via their tongue. Only a few volts are needed to produce the 1.6mA need for a recognisable pixel. Electrodes of 2.13mm were used on a 2.34mm, Although other spacings and contacts down to 1.55mm in size will work.

# X-rays say why ferroelectric memory forgets

Ferroelectric memories, a new class of non-volatile storage device, lose data.

Now scientists from the University of Wisconsin-Madison and the US Argonne National Laboratory have taken a step towards an explanation.

"The neat thing about these materials, is that they have built-in electronic memory that doesn't require any power," said Madison researcher Paul Evans. But

"eventually they quit working".

The memories store data bits in their arrangement of atoms, which can be modified and read electrically.

However, each write pulse diminishes storage ability "until they either forget the information or quit switching altogether", said Evans. "It could switch 10,000 or even millions of times and then stop working."

With colleagues, Evans used

the US's most powerful X-ray source, the Advanced Photon Source at Argonne, to measure atomic locations.

The experiments showed progressively larger areas of the device cease working with each write. "After 50,000 switches, the atoms were stuck - they couldn't switch anymore," said Evans, who also found a higher voltage pulse puts the atoms back in motion.

When the researchers used more voltage from the beginning, switching stopped 100 times later, when further boosting voltage made no difference.

"With higher voltages, the material can't switch because something has changed about the material itself," said Evans. "It's not just the switching that stops working, but something even more fundamental."

## Hidden codes in photos Power chip firm goes to Wales

Fujitsu has developed a technique of embedded ID codes, web links and phone numbers in printed images without degrading the quality of the image.

Up to 12-digits of numeric data can be embedded into an area as small as 1cm<sup>2</sup>.

The technique exploits the characteristics of the human eye, and its sensitivity to colour and size. Data can be embedded in digital camera images and can be successfully printed using home quality colour printers.

Fujitsu expects that the first use of the technology will be to pass data to mobile phones. In Japan mobiles are often used to scan one and two dimensional barcodes to gain information, but manufacturers do not want unsightly barcodes all over their goods.

A phone could extract 12-digits of information in around one second using the processing power already available, said the firm. This shows an advantage over digital watermarking which requires significant processing power.

Swansea has been chosen by power semiconductor maker Vishay Siliconix as the location for a chip design and development centre.

Sited at the Digital Technium in Swansea University, the Power MOS and Linear IC Design Centre will be headed by Dr. Dilwyn Williams and Richard Davies, both returning to Wales from overseas.

"Attracting a global company of this calibre is further evidence of the outstanding success of the network of Technium innovation centres," said Welsh economic development minister Andrew Davies.

### Berlin engineer attracted by York's magnetism

A Berlin engineer, Gerd Merklein (54), who graduated from the University of York in July, commuted from Berlin for six years to attend exams and residential teaching at York.

Gerd studied part-time for an MSc in Electromagnetic Compatibility & Radio Frequency Communications. He manages a team of electricians and engineers maintaining wireless communications for automated logistics operations for a German stationery manufacturer, Herlitz PBS.

He chose York because there are no equivalent professional development courses in Germany.

Teaching is predominantly self-study, with one to two weeks of residential teaching each year. The course normally takes around four years - at any given time there are between 40 and 50 students on the course.

[www.york.ac.uk](http://www.york.ac.uk)

The academic expertise of the power electronics group at the university was said to be a deciding factor in locating the centre in Swansea.

"When companies like Vishay Siliconix make an investment like this it is noticed and sends out a very positive, very strong message to industry," said Technium director Dr Steve Davies.

"These design centres play a key role in enabling innovative technology companies like Vishay Siliconix to maintain their global market lead."

Up to ten staff will be recruited at the centre in functions such as

analogue IC design, IC layout, and production engineering.

Vishay's announcement coincided with the launch of the £4.3m Digital Technium, which joins specialist centres for optoelectronics and automotive in Wales.

The Swansea centre includes a £2.6m Agilent Laboratory and a virtual reality facility allowing researchers to visualise products in 3D from heart valves to new cars. The £0.5m 'VR Cave' has three screens each measuring 8x10ft.

Six firms have already signed up to Digital Technium, which has space for 13 companies.

### UK Resource Centre Website Set to make a big hit

The new UK Resource Centre for Women in SET (Science, Engineering, and Technology) has launched a new resource website today at the Institution of Electrical Engineers, with a lunch for women in SET.

The Resource Centre is a significant development of the Government's strategy to increase the participation and progression of women in the sectors. The Centre was one of the key recommendations in the Greenfield Report, which identified the need for greater coordination of information, resources, knowledge and good practice. The comprehensive website has been developed to act as the central source of information to provide informed solutions to employers including academia, professional institutes, research councils, careers professionals and educationalists whilst providing access to mentoring and networks for women and girls entering or

already participating in SET learning or work. The website launch was attended by women representing the breadth of SET occupations. All agreed that the website would provide immediate support on areas including research, women role models, case studies and mentoring guides.

Pam Wain, President, Women's Engineering Society, commented: "The new website is another useful step forward for women in the sector. We have so much to contribute and welcome this way to help us to be more effective. We look forward to the new Resource Centre becoming fully operational." The new website can be accessed at [www.setwomenresource.org.uk](http://www.setwomenresource.org.uk) The UK Resource Centre's official launch will take place on 16 September 2004 at the Royal Armouries, Leeds.

# 2004 PRICE BUSTERS

In line with our policy of producing top quality products at amazing prices we have reduced the price of our best selling items by up to 50%

Don't delay - this is for a limited period only!



### 19" Horizontal 2U High

4	Sockets	13A/4/R	@	£22.65 ea. Nett
5	Sockets	13A/5/R	@	£24.99 ea. Nett
6	Sockets	13A/6/R	@	£27.57 ea. Nett
7	Sockets	13A/7/R	@	£30.96 ea. Nett

### Vertical

4	Sockets	T13A/4	@	£20.25 ea. Nett
6	Sockets	T13A/6	@	£24.60 ea. Nett
8	Sockets	T13A/8	@	£31.47 ea. Nett
10	Sockets	T13A/10	@	£34.95 ea. Nett
12	Sockets	T13A/12	@	£39.62 ea. Nett

### Vertical Left Hand with Switch

4	Sockets	4LH/MS	@	£20.25 ea. Nett
5	Sockets	5LH/MS	@	£23.37 ea. Nett
6	Sockets	6LH/MS	@	£24.60 ea. Nett
8	Sockets	8LH/MS	@	£31.47 ea. Nett
10	Sockets	10LH/MS	@	£34.95 ea. Nett
12	Sockets	12LH/MS	@	£39.62 ea. Nett

### Vertical Right Hand with Switch

4	Sockets	4RH/MS	@	£20.25 ea. Nett
5	Sockets	5RH/MS	@	£23.37 ea. Nett
6	Sockets	6RH/MS	@	£24.60 ea. Nett
8	Sockets	8RH/MS	@	£31.47 ea. Nett
10	Sockets	10RH/MS	@	£34.95 ea. Nett
12	Sockets	12RH/MS	@	£39.62 ea. Nett

WHEN IT COMES TO POWER FOR RACKS IT MUST BE

# OLSON

### Olson Electronics Limited

490 Honeypot Lane, Stanmore,  
Middlesex HA7 1JX  
Fax: 020 8952 1232  
e-mail: [sales@olson.co.uk](mailto:sales@olson.co.uk)  
<http://www.olson.co.uk>

SEND FOR YOUR NEW FREE CATALOGUE

CALL OUR SALES HOTLINE  
**020 8905 7273**

This promotion cannot be used in association with any other discount or offer. Olson Electronics Ltd reserve the right to change the price without prior notice.

# Class-A imagineering: Part 4

Graham Maynard's valve (tube) based amplifier observations and power comparisons have not yet been fully stated, but these findings are not necessary for him to introduce the first of his two class-A designs; as shown here

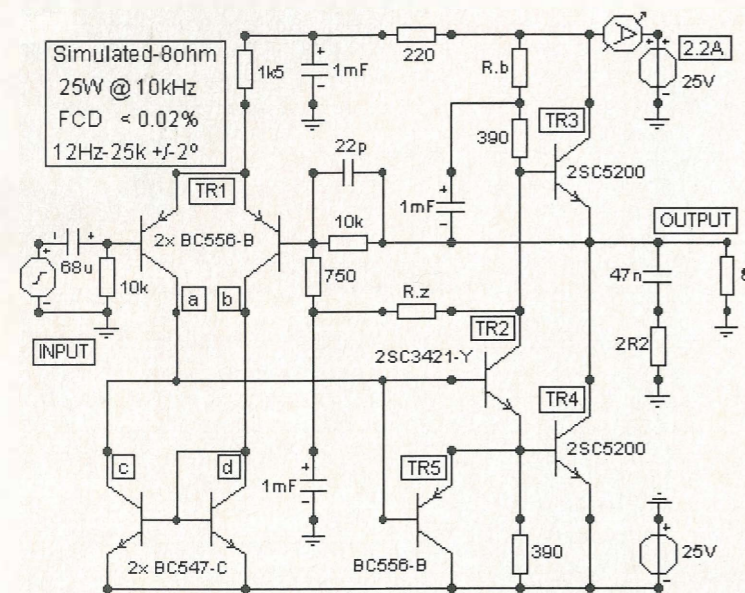

The simple 25W-8W pure class-A audio amplifier circuit.

This genuinely 'hi-fi' pure class-A specified design is obviously similar to the 1969 and 1996 circuits due to John Linsley Hood. Naturally efficient and same type NPN bipolar transistors continue to be used in both push-pull output halves, though here much more gain linear devices run within a faster circuit topology that has a differential input stage, dual power rails, plus a directly coupled output stage having a more accurately stabilised offset zero than with the 1996 update.

At this point I am taking a late text revision opportunity to suggest that readers study the original 1969 *Wireless World* article as respectfully reprinted by *EW* in the June 2004 issue. The non-complementary output stage shown in Mr Hood's original figure 2, and which is used in my figure 10, is fundamentally different to all other types. Its composite functionality must be analysed as a whole; not on a per-

half basis as can be done with most other class-A and class-B output stages. For simplicity JLH illustrated voltage drive with resistors connected directly to the voltage rails - which is less linear, however, when the driver/splitter transistor is properly current driven via a high impedance source it can run both 'constant current sharing' (bootstrapped) output devices as properly reciprocating, class-A push-pull, current amplifying, common emitter output halves. As is usual, the voltage sensing NFB loop ensures overall input-output voltage gain linearity with reactive loads. If the resistors connected to the bases of the output devices have different values then this upsets the natural balance, as do individually different device gains + gain variations with device current and alternating headroom voltages + dynamic signal/NFB induced high frequency junction capacitance and storage effects separately acting upon

the splitter transistor's collector and emitter. However all three transistors will continue working together as a class-A output stage, if maybe just a little less accurately at higher output and frequency due to their dynamically induced output-half mismatching, which also happens in class-B amplifiers anyway, only there having a greater effect because there is then only one half capable of correcting the errors without a conduction crossover being invoked. Before the arrival of computers I also ran this non-complementary output stage in a much more efficient class-A configuration which had dynamically self adjusting bias, as well as in classes 'AB' and 'B', but the naturally low waveform distortion, good bias and temperature stability, also the low propagation delay which assures phase coherent NFB loop control, always became impaired such that all of the extra work and circuit complexity involved was not worthwhile. I did however, learn much from my efforts.

To read more about this output stage visit; [www.tcaas.btinternet.co.uk](http://www.tcaas.btinternet.co.uk) and read the -/jlhoutput.pdf - page.

## The Amplifier

In order to minimise overall circuit propagation delay, which simultaneously lowers both an amplifier's first cycle distortion, and the NFB loop generated output impedance that dampens loudspeaker back emf induced output terminal error voltage shift wrt input waveform at all, and especially tweeter driving audio frequencies, I concluded that:-

(a) there should not be any input filtering; the system bandwidth should be set by the pre-amplifier and/or a prior recording medium.

(b) the amplifier's stability margin should be extended by increasing the differential input pair tail current to at least 10mA with suitable devices.

(c) to maximise TR1a,b,c,d input stage voltage to current transfer linearity, also to minimise output stage inductance at high audio frequencies, the TR2 current splitter stage should not be fitted with any form of directly connected dominant pole Miller capacitor; this keeps current node impedances high and minimises phase shifts to ensure fast and accurate NFB loop induced error corrections.

(d) there should not be any emitter resistors to drop non-linear quadrature voltage between the mirrored differential input stage transistors due to 90 degree leading TR2 C-bc charging currents during high slew NFB loop controlled output drive.

(e) to maximise efficiency without increasing complexity or propagation delay TR2 should remain a singleton; this optimises the current to load-voltage transfer characteristic for the composite output stage without introducing additional device non-linearities.

(f) there must not be any series output capacitor or choke, nor too low a value of input capacitor, nor an uncompensated NFB resistor, any or all of which could lead to potentials at the differential input stage becoming phase shifted wrt the user input and output terminals, the voltage waveforms of which the differential input pair should be near instantaneously attempting to match, with a view to minimising all output terminal distortion wrt live and constantly changing input, regardless of reactively altered load current flows.

There will be those who believe I am wrong to not use an input filter as stated in (a) above. However, I do not feel obliged to satisfy others when I have never had any problems associated with the sensible usage of this type of amplifier. Yes I have had to deal with the odd case of taxicab or BBC-FM breakthrough with professional stage amplification and music installation equipment, and I have always managed to effect cures by fitting ring cores and/or resistor-capacitor filters on a per-site basis, but I would not suggest degrading the performance of every home used amplifier to ensure that the few which might suffer from electromagnetically induced interference will be protected; that's like wearing a raincoat all summer long instead of carrying one in case of need, but I still could never state that such a choice is wrong. My success with this circuit might however be due to always fitting an output Zobel network, as here with 47nF and 2.2k, so that the output stage is always loaded at high frequency, and not free to oscillate.

I am also quite aware that emitter

resistors are often fitted to input devices, (d) above, in order to minimise output terminal zero error drift with temperature. However I always keep the input transistor pair together away from radiating or conducted heat, and have additionally covered offset by using an alternative arrangement - R.z - which will not leave input stage high frequency linearity at risk from momentary degradation due to leading TR2 C-bc slew charging currents, especially when load current flow is out of phase with signal input voltage, which does not show up if testing is done using resistor loads only.

I could also imagine someone writing in to ask why I have not used a constant current source to supply the differential input stage tail current. Reason;- the emitter node already runs at low impedance and so current sharing will not be significantly affected by a resistor in the same way as can arise when emitter resistors are placed in series with individual input devices. There is no advantage to be gained from using a current source, so why use several components when one suitably chosen resistor will do?

When good NPN transistors first became available I remember my 'best' small signal circuits being OC44-BC107C combinations. 'Best' referring to their bench measured fundamental nulling distortion performance at 1kHz, where a degree of PNP-NPN transfer-error cancellation between the opposite polarity device stages produced lower distortion figures than either 2x NPN or 2x PNP could manage alone! Slight fortuitous distortion cancellation can occur here, as indeed it can within the original JLH class-A circuits, but do note that this applies to the THD figure alone, which does not reveal any high audio frequency first cycle input and NFB inadequacies.

Actually, using additional components to artificially reduce THD always has the potential to degrade a first cycle or transient response. For example, feed-forward with its momentarily increased NFB loop controlled current flow during the first couple of microseconds of a new waveform event, can lead to the 'tuning out' of steady-state distortion products through say a following 10kHz sine wave, but the feed-forward is specifically related to input-output signal voltage propagation and not necessarily to a fast and out of phase NFB loop energised load current correction. It is the potential for non-linear small signal stage current flow during that initial feed-forward period that can increase transient (first cycle) distortions in class-B bipolar amplifiers in exactly the same way that a Miller

connected C.dom can when the load is reactive. All additional capacitors connected to the signal path within a closed NFB loop cause additional leading current flow between their take off and application nodes, creating a potential for increased leading edge reproduction inaccuracy when the load is a dynamic loudspeaker instead of a passive resistor.

With my new circuit having increased open loop gain and speedier output transistors than the 1969-96 circuits, subsequent computer simulation showed:-

(1) better low distortion push-pull operation at high audio frequency is achievable when TR2 emitter and collector resistors are equal, as here with 390Ω; this allows for faster and better balanced push-pull NFB sensed error correction control within, and up to, the limit of the phase coherent small signal bandwidth frequency range.

(2) TR4 was slower to turn off on positive going square waves. It is assisted here by the addition of TR5, a pull down transistor which sinks to ground TR4 collector-base charges, in much the same way as TR2 removes TR3 collector-base charges on input overdriven negative going transients. The rather strange looking addition of TR5 does not pass any current until after TR2 base has been turned fully off by input mirror overdrive, whereupon it quickly shunts TR2+4 storage that would otherwise have a potential to slow their response and induce output stage cross conduction during high slew NFB loop induced drive corrections close to maximum output.

(3) increased input stage tail current flow helps to increase the unity gain stability margin to approximately 100 degrees, almost twice that for earlier JLH class-A designs with their 350μA first transistor current flow.

(4) with 390Ω splitter resistors in use, this class-A output stage is more efficient, faster, and more phase linear with the original JLH-69 bootstrapped resistor bias source than it is with any other type of transistor current source. Unfortunately this means that the initial setting up of quiescent current once again becomes a trial and error procedure for selecting a value of R.b between 150Ω and 470Ω, though once set the current then remains stable after just two minutes of junction warm-up time.

(5) a similarly empirical selection for R.z of between 100kΩ and 1MΩ leads to an excellent degree of output terminal zero voltage stabilisation so that offset drift is minimised; the minute change of current flow through R.z due to TR3 base-emitter junction

voltage variation with temperature and power rail fluctuation, counteracts drift by reducing the offset potential down to flicker levels shortly after switch-on; do though allow the amplifier to operate normally for about an hour in its usual enclosure before attempting to select a permanent value for R.z.

(6) slightly better simulated THD test results can be achieved by optimising positive and negative transfer error cancellation, by using a different mirror, or by adding other components. Several alternatives were tried in real-life but there was no change in reproduction when compared to this very neat and basic circuit.

With its self biasing differential input stage this circuit should work with any dual supply potential between  $\pm 10$  and  $\pm 40$  volts DC, yet it is also possible to reconfigure for single positive rail operation by removing the  $10k\Omega$  input resistor; adding the conventional bias resistors from Part1-figure1; inserting a  $22mF$  capacitor in series with the loudspeaker and, linking all zero volt connections to the negative rail. Twin power rails are advantageous however because they remove the need for that expensive series output capacitor which unavoidably increases low frequency loudspeaker induced output terminal distortion, and can also make the bass cone thump during an initial power-up charging to half of the supply potential unless the bias and bootstrap circuits are both made to take at least five seconds in charging to their working potentials.

A suggested 'first-try' value for R.b is  $270\Omega$ , but do remember that this part must be rated to cope with the additional power it could dissipate due to a maximum output square wave voltage being developed across it via the bootstrap capacitor, as well as to the heating effect from static bias current flow. Also note that this amplifier's gain setting NFB divider resistor value is not critical. The  $750\Omega$  component shown in figure10 is correct for 25W of output into an  $8\Omega$  load with 1V.RMS of input.

If you intend using recently manufactured parts then I recommend Toshiba 2SC3281 and 2SC5200, or On-Semi (Motorola) MJL3281A and MJL4281A output transistors. If you have old 2N3055s, or for that matter any other power transistors to hand, then it really is worth trying them too - just build to their rated current, power, voltage and safe operating ratings. My 2SC5200s still run without problems at  $\pm 25V$  and 2.4A ( $R_b = 220\Omega$ ) with additional draught from an enclosed 12V fan running inaudibly at 6V unless you are very close to the back of the amplifier. One push-pull pair of these

lower base capacitance and more gain linear transistors is good for 30W into  $6\Omega$  resistive.

For the current splitting transistor I recommend a Toshiba 2SC3421 or the more widely manufactured BD139, with no more than a clip-on heatsink at its back in higher power versions. Some other types are equally suitable, but might not be widely obtainable. The 2SC3421-Y has a much higher DC current gain than BD139s, but real-world comparison testing has shown that it does not make the amplifier reproduce differently. With a lower gain driver the only difference noted on the simulator was a fractional increase in output impedance, which is always swamped by loudspeaker cable resistance anyway; the distortion figures remained virtually unaltered!

As a note for those who might wish to build more powerful versions by using paralleled output devices, say for  $4\Omega$ ,  $2\Omega$  or  $1\Omega$  load driving, I suggest that both of the  $390\Omega$  splitter resistor values be dropped to  $220\Omega$ ,  $120\Omega$  and  $68\Omega$  respectively, with R.b and possibly a different driver being chosen to cover any increased dynamic requirement. Emitter resistors should not be used in the figure10 or JLH class-A output stages unless parallel output devices are being used; these are current and not voltage driven circuits! Unmatched power transistors used in parallel will generally work with  $0.47W$  current sharing emitter resistors, but even when they are matched I still prefer to not go below  $0.33\Omega$  when higher supply voltages are used. Also; do not forget that these emitter resistors should be non-inductive, and not just plain ordinary low resistance wirewounds.

### Real performance

For those who are still interested in steady state specification figures, the simulated distortion at 10kHz for 25W into  $8\Omega$  is less than 0.003%, falling below 0.001% by 1kHz and 10W, even with good 2N3055s. The distortion specification, frequency response, and signal to noise ratio are up to those which would normally be expected from a 21st century design, but it is the phase accuracy that is especially worthy of note because this is flat to within  $\pm 2$  degrees between 12Hz to 25kHz at rated power, which makes for cleaner low and high frequency responses than valve and most other class-B designs can manage.

Whilst increased NFB lowers the distortion, it is the mirrored differential driving of TR2 with its  $390\Omega$  resistors that gives this circuit its flat topped open loop gain of approximately 80dB out to 30kHz. Also, there is no longer

any non-linear waveform modulation of the input stage NFB current which arose within the original designs due to them having a single input transistor which simultaneously modulated the NFB loop potential in sympathy with transistor current flow related to phase shifted driver and output demands with reactive loudspeaker loads. This combining of the bias and NFB current flows in the original circuits, with additional series input, output and NFB capacitor zero potential averaging, could give rise to a gentle 'pumping' effect upon reproduction, to the extent that the bass loudspeaker cone could be seen gently 'breathing' in sympathy with the increased need for output stage current drive at higher output levels on bass-less voice or mid range instrument drive.

This was my reason for implemented the differential input stage, which many existing JLH class-A users might then view with scepticism through their association of its use with less good sounding amplifiers which were often fitted with a Miller connected C.dom. However, it is the less inaccurate voltage input-NFB differentiating at the input stage of my '25-8' circuit which has removed that bias 'pumping' distortion characteristic (which some users might not have noticed, or thought curious but not unacceptable), and which has set this design apart from the earlier versions. The simulated THD might be much lower but I regard this as irrelevant because the original JLH class-A's were good enough already. The equivalent FCD figure is also no more than three times better for it too had already been excellent, so I believe that the only other slight audible improvement relates to a slightly improved phase response and a more accurately controlled loudspeaker back EMF damping. There is now very tightly controlled bass drive to the limit of output powering capabilities, while the treble retains dynamic clarity to higher output levels.

I had so long ago heard signal path capacitance and output chokes degrading reproduction, but I was unable to prove anything. This left me wondering whether so many published designers actually listened to their designs, and how they could avoid being openly truthful with their public; or were they merely satisfied at being able to present 'unchallengable' specifications. Even a 0.0001% THD specified power amplifier is incapable of regenerating equally accurate sounding audio via real-world loudspeakers if it uses an internal series output choke to ensure smoothly stable class-B operation. So what good is

testing a supposedly 'perfect' design under steady state conditions, when connecting real world loudspeakers in place of a passive resistor can be heard causing music distortion through parallel connected headphones?

This is why I quote a different specification for my 25W- $8\Omega$  class-A audio chassis, and I state that its equivalent first cycle THD, or its 'FCD' figure within the safety margin of a 100kHz bandwidth specification, w.r.t. input, for 25W at 10kHz and into  $8\Omega$ , is a more modest 0.02%. By comparison, a 'perfect' (computer simulated) amplifier with  $6\mu H/8.2\Omega$  also driving an  $8\Omega$  resistor only manages 0.37% of first cycle THD at 10kHz. Now should anyone attempt to massage the choke FCD figure by starting the measurement after the group delay time period has elapsed, it still works out at 0.22% due to the amplitude displacement of incompletely settled exponential input rise as pointed out in Part2-figure2. With a more human like 30kHz examination bandwidth read 0.008% FCD w.r.t. input for my amplifier, but still 0.19% w.r.t. input, or 0.12% w.r.t. output for  $6\mu H$  choke coupling. Also if anyone thinks that 0.02% is a poor figure for first cycle distortion then I challenge them to check out other 'user available' amplifier circuits, and to observe the simulated leading edge changes introduced by input-output filters, bipolar-Mosfet stages, one-two-three stage architectures, also feed-forward and stabilisation paths within a NFB loop, as well as different types of NFB loop enclosure.

Now, before anyone thinks about writing in about group delay not affecting sine wave distortion, or real-world dynamic loudspeaker system impedance swamping output stage characteristics, please note that my 'FCD' figure is already inclusive of these aspects without any need for clever posturing that hoodwinks the public. Yes I know that genuine 'group delay' via a transmission line cannot be heard, and that some of this this equivalent distortion figure is caused by delay, but the effect of a series input filter or a slow amplifier, or an output choke does audibly affect reproduction by making it sound 'smoother' and rendering reproduction less clear. They cause a momentarily subtractive error which lasts for longer than the steady state measured group delay period suggests on first cycle leading edges, and the greater the transient/harmonic content the more noticeable the error. If you can hear a difference - then the audio waveform is being distorted, and that difference is due to the

dynamic alteration of first cycle waveform coherence.

This is a long overdue wake-up call. We need to move on beyond simplistic and isolated steady state fundamental nulling distortion measurement techniques at a the output terminal, because it tells us nothing about what might already have happened to a leading and often asymmetrical first cycle audio waveform prior to the development of low steady state THD. Normal music waveforms have some of their most importantly recognisable combinations of harmonics characterisingly combined within first cycle leading edges. 'First cycles' also tend to have the largest amplitude, and yet designers have been failing to report (and maybe not even been examining either?) their amplifier's first cycle transient performance capabilities. Even after accepting that an amplifier introduces a group delay time period, there is still first cycle output distortion at  $t=0$  for every new waveform we eventually hear; that is why I aim to minimise all delay and first cycle errors from  $t=0$  wrt input.

Every amplifier needs to be tested for FIRST CYCLE THD, which will directly relate to an input filter, output choke, signal path devices and their capacitance shunting, which cannot fail to affect transient capabilities during the time it takes for exponential circuit settlement to complete whilst the amplifier circuit is simultaneously following constantly changing audio signal waveforms and attempting to NFB loop control dynamically induced and phase shifted loudspeaker current flow. This directly relates to the way in which a pair of dynamic stereo loudspeakers can subsequently regenerate a sound image at moments of high harmonic content or sibilance or percussive attack, and especially during those moments of coincidentally generated loudspeaker back EMF. By using a 'FCD' figure instead of 'n'th cycle THD, maybe then we will be better able to identify at the design stage those amplifiers which are more likely to be capable of responding to constantly changing audio waveforms, without distracting arguments about the application of any author's technical knowledge, or a listener's subjective opinion, also without risk for an individual's occasional omission of facts leading to irrelevant points being nit-pickingly deconstructed without topical regard.

The only folk I can see grumbling about my proposal are those who have already designed amplifiers that do introduce propagation delay and first cycle amplifier-loudspeaker reproduction problems, but for them

to then knowingly continue not giving our public the clear sounding amplifiers they really want, would cause even more grumbling against those of us who read these pages, especially when an excellent first cycle performance is so easily attained. Unfortunately first cycle THD examination is not a procedure that is easy to retrospectively set up on the test bench, though it is worth noting that any amplifier having series output inductance that exceeds the equivalent of  $1\mu H$ , whether that is choke or propagation delay generated, might already be at the acceptable limit when attempting to guarantee coherent reproduction via real world loudspeakers.

### First Watt listening

I cannot disagree that the JLH class-A circuits might look as if 'stone-age' (not my words) to those students of some 'transistor-age' designer-writers who have shown us how to achieve ultra-low distortion and ultra fast slew rate circuits when the load is entirely passive. However I also understand that such comments tend to come from those who lack direct 'hands-on' and 'ears-on' experience of JLH designs. There are so many circuits capable of exceeding  $50V/\mu S$ , but as with THD, this figure will not be of real-world value unless the amplifier linearly slews 50v within the first  $1\mu S$  of  $t=0$ . So many designers drive their amplifiers with a steady square-wave, and some even deliberately overdrive by a considerable margin, in order to be able to specify fantastic plus-to-minus, or minus-to-plus slew rates at  $\pm 90\%$  of peak amplitude, as if the results are useful design pointers relating to accurate sound reproduction. Yes, unavoidable input overdriving should not upset an amplifier, and we need to be sure that it can respond and recover quickly, but what about its initial immediacy? What about that initial exponential start-up waveform and the 10% corner change shape being properly examined at the output terminal when a representatively reactive loudspeaker load is connected?

The JLH class-A circuitry has so few signal path junctions, without any additional path, or stabilisation, or NFB capacitors, so there is only the tiniest of delay between an input arising and its fully NFB controlled output becoming naturally and stably amplified. As a result, and unlike most other amplifiers, the original JLH has a first cycle response that closely matches its measurable 'n'th cycle THD figure. The JLH class-A's also present loudspeakers with a 'softer' and more valve-like source impedance, which,



with lower damping levels, is slightly less controlling of complex loudspeaker system reactivities.

Unlike valve amplifiers however, and so many other solid state amplifiers too, the output impedance of the JLH-96 and my '25-8' is virtually resistive at all audible frequencies. Neither are low frequency capacitive, as with the JLH-69, nor high audio frequency inductive, as is the case with so many other designs, except for the odd well thought out one or two stage architectures which do not need to rely upon additional capacitively shunting delay to maintain NFB loop enclosed stability.

These comments once again bring me back to first cycle distortion mechanisms, for the equivalent FCD figure with the JLH class-A falls with reducing amplitude and measured THD. However, with most other high NFB amplifier designs, the first cycle distortions do not fall in the same way because the THD figure is already negligible. The first cycle errors that arise in other amplifiers are generally related to their architecturally fixed causes, and, apart from loudspeaker delay induced non-linearities, these do not change significantly with amplitude. The more that NFB techniques are employed in an attempt to minimise propagation delay and stabilisation circuitry induced errors, then the greater is the potential for FCD and reactive errors being generated at higher audio frequencies, irrespectively of amplitude. With most modern power amplifier designs their first cycle responses cannot be improved by increasing NFB or by running them at reduced output powers, and this is why their equivalent FCD figure needs to be low at the outset, which is the case with my '25-8'.

Now many listeners use higher power systems at 'First Watt' listening levels to be sure that amplifier distortion levels are low, that dynamically generated loudspeaker back EMFs do not place undue demands upon their NFB loop controlled amplifier circuits, and that loudspeakers transduce as linearly as possible. What they are really doing however, is taking the constant level of system induced FCD errors down to levels where they become naturally masked by threshold hearing capabilities at lower sound pressure levels. This is why it is very hard, and often impossible to distinguish between different good amplifiers at low listening levels; the errors are still there, but they are rendered inaudible, and it is only when the source program is good enough and the 'volume' is turned up that differences begin to

show, as at public performance equipment sound levels.

When the JLH-69 amplifier circuit was originally published its very wide bandwidth initially went unnoticed because it exceeded that of the measuring equipment being used. Subsequent 'concerns' about its surprisingly high frequency response led to suggestions for artificially limiting its bandwidth by fitting additional resistor-capacitor signal path filters. I had already constructed an amplifier and had it working perfectly satisfactorily before reading about these modifications, which I then felt obliged to implement.

But these additional components completely ruined its dynamic reproduction capabilities, and so were immediately cut out again!

Later I checked out the input filters that started becoming integral with so many designs as an artificial way of reducing TID in poorly designed amplifiers, but these too affected reproduction. Eventually I tried buffered input filters having different turnover frequencies many times my own single frequency - steady sinewave - hearing capabilities, but either their frequency was so high that the insertion was pointless, or there was an audible effect upon the leading edges of sibilants and percussive sounds when the amplifier was being used to reproduce at realistic sound levels. Well that made my mind up, I would not be using any more artificial bandwidth limiting circuitry - and - since then I have never had any stability problems with this two stage class-A topology as a result.

It is a fact that I cannot hear bats, but I can occasionally sense their echo location calls. I have also experienced sonically induced sensation, as from finding myself near to a young bat that had lost its mother, and from being in line with a 25kHz energised supersonic transducer. So, although I cannot 'hear' all of the harmonics that are generated by a percussive drumstick rim strike, I can and do sense that something from real life is missing when that same sound is reproduced via a high quality CD playback system; and I don't blame the transducers or known good amplifiers either!

So where do we set our levels for excellence? I do not know! Without any filtering an original JLH circuit simulates at an equivalent of about 0.05% FCD at normal listening levels, and they reproduce all first cycles and harmonics cleanly as long as the driven loudspeaker is not overly complex or reactively difficult. They are particularly good at driving transformer driven and highly

revealing electrostatic loudspeakers. To me the JLH class-A's are like old gems - they never lose their sparkle! This is why I have worked for so long at increasing their loudspeaker powering capabilities whilst retaining their natural immediacy.

Throughout solid state amplifier history there have been designers who have fitted one or more capacitor or resistor-capacitor networks between a high impedance gain stage node and the signal ground to control hf bandwidth and thereby ensure stability. However more than myself had observed that even though these amplifiers came with unconditional stability and full 'hi-fi' specifications, and they were fine for driving electrostatics loudspeakers, they were much less satisfactory when it came to driving dynamic loudspeakers loudly, as for discos. This though is only to be expected when it is considered that loudspeaker induced NFB loop error sense transient generated correction currents become leading edge loaded by these very same signal path connected capacitors, as similarly happens with some Miller connected C.doms though then without the class-B output stage bias crossover induced input stage current spiking that Miller capacitors can cause.

A recent simulation of the old JLH circuit with those bandwidth reducing 'stabilization' components added, showed that the THD figure remains unaltered, but that the FCD figure exceeds 2.0%! These signal path connected capacitors had had an undeniably audible consequences upon pop-music reproduction. This leaves me pondering a halving of that audible/measured effect, with a ten times reduction safety factor to be acceptable for quality assured listening, bringing me back to that old 0.1% valve distortion 'hi-fi' standard, though via an entirely different route. The simple JLH-69 and my '25-8' already satisfy this stringent FCD requirement, but how many other designs are genuinely and equally capable?

Digital amplifiers must be fitted with output filters. Will these ever be capable of achieving <0.1% of 10kHz first cycle distortion, and thereby be properly able to drive real back EMF generating dynamic loudspeakers with audio waveforms in a manner whereby they can become an integral part of a system that can properly gift the necessary cerebral illusion of reality? Also what value is there in a phenomenally low THD figure for constant sinewave distortion, when there can still be unmeasured and unquoted first cycle non-linearity acting through the dynamic amplitude

changes that arise within the CD recording medium?

This brings me to the question of validity for test bench or simulation testing an amplifier by using an 8 $\Omega$  loading resistor, for where in this world is there a cable-loudspeaker-crossover combination that does not present the amplifier with an additional series inductance of say 10 $\mu$ H, and in many cases more than 50 $\mu$ H? There should of course always be driver impedance compensation, but when this is part of a crossover network it also can increase first cycle problems within NFB loop controlled amplifier designs that are unsuitably pressed into audio reproduction duties.

Curiously, the non-complementary output stage first championed by Mr.Hood in his class-A designs is less high frequency slew rate limited when its load is a real loudspeaker or an ordinary wirewound resistor, instead of a genuinely non-inductive test bench component. Thus these 'old' class-A circuits can be particularly faithful when driving full range loudspeaker systems, where 'established' test bench and computer simulation measurements might suggest otherwise. The JLH-69/96 circuits are excellent examples for revealing to those who rely upon measurement procedures and computer simulation investigations, that what they think they 'see' does not actually match what is eventually 'heard'. We are very likely to 'see' better steady-state THD simulation results being produced by other modern class-B designs, yet we may be just as likely to find that the use of these simple class-A circuits can provide an indisputably superior listening experience! Maybe designers would 'see' more by studying and comparing their own circuits' first cycle capabilities with representative virtual loudspeaker loads, instead of by only minimising THD with plain and passive resistor loads that are incapable of properly loading the circuit due to the lack of reactively generated back EMF.

All amplifiers should be auditioned with a variety of real world loudspeakers, and if circuit simulator examining - run into 'representatively complex virtual loudspeakers'.

### Surprisingly good

100W of dissipation is about as far as it is possible to go with plain convection cooling and a single pair of normal output transistors. More powerful devices are available within Hpak outlines, like the 2SC2922 and some more recent variations. These might be better treated as if they already are a pair of paralleled devices by fitting

220 $\Omega$  instead of 390 $\Omega$  current splitter loading resistors; 40W of pure class-A from just one pair of output devices appears realisable, and possibly 50W with forced air cooling! At least the OnSemi and Toshiba types listed above should be available for some years to come. BC547C and BC556B transistors cost only pennies each, so order extra and rig up a circuit to pair match characteristics at 5mA. To maximise power output always use the highest gain output transistor in the position of TR3; this is because it has only the series 390 $\Omega$  resistor driving it, whereas TR4 can receive additional currents via TR2. Now that there is much improved output stage linearity and more NFB, distortion is no longer the deciding factor.

A 1 $\Omega$  version with  $\pm$ 15V rails and set up for a 5A quiescent current using a single pair of 2SC2922 output devices should be capable of directly driving a ribbon tweeter element. That is, a ribbon tweeter driver without any need for a matching transformer being inserted within its signal path! Ribbons present near-resistive loading, which means that dynamic damping is no longer of prime importance, so when short leads are used this amplifier's NFB capacitor value may be tried at 10pF.

The physical construction for this amplifier may follow that already used with an existing JLH-69 class-A chassis, and amplifiers could be updated whilst reusing the heatsink mounted power transistors that are already fitted. Make a convenient star earth point, and fit/use a ground insulated input socket. Also keep the input circuitry plus TR1a,b,c and d, at one end of the circuit board away from driver and output transistor, power rail and loudspeaker output wiring terminations which should be brought to the board radially at the other end - i.e. with no significant currents flowing through PCB tracks. It is essential that connections to the bases of TR1a and TR1b are kept short with a compact input stage layout; also use a screened cable between the input socket and C1. It is also easier to later update, modify or repair an amplifier when its power devices do not have to be removed from heatsinks because they have been made integral with the circuit board. Do not twist or lace wires that go out to the power devices; my choice for open construction is to use the PVC insulated solid copper conductors from low rated twin plus earth or three phase cables, which can be formed to neatly follow any chassis outline and maintain a mutual 1cm spacing; or if the layout permits, use extra-flexible high current cable. The 'star' earth may be a

dedicated pcb etching, or a series of solder tags bolted tightly together in a spiral though quite literally star pattern. Try to keep TR2, TR4, output terminal and Zobel connections short wrt the star earth point.

I freely admit that I had had concerns for the risk of oscillation when using a differential input stage with these modern 30+MHz gain-bandwidth output transistors, especially with leads that were 15cms long out to large electrically insulated heatsinks which had the power devices mechanically and thus electrically bolted directly to them in order to minimise output junction heating. This is because it is hard to estimate PCB inter-track and body capacitances and the lead inductance values we should enter into a computer simulation programme. Also, computer programs show frequency-phase-Nyquist plots for predetermined conditions only, not those that match widely varying audio induced driving. Square wave simulation with impossibly fast rise times, and the use of idealised device models can even suggest instability where none might be apparent in real life because the software derived high frequency response and output characteristics lead to much faster circuit reactions. Equally, some amplifiers will be unstable due to physical construction interactions which will not show up in software generated tests.

The internal base-collector junction capacitance of the current splitting driver transistor already acts like a low value high frequency C.dom acting above audio frequencies, and thus control is maintained with no more than the Zobel output filter and 22pF NFB correction capacitor shown. This latter component is fitted to prevent the 10k $\Omega$  output node sensing resistor from becoming part of a low pass filter within the NFB loop due to capacitance at the base of TR1b, which would then create a potential for loop enclosed phase change and load induced instability; it also optimises high audio frequency loudspeaker back EMF damping. When my circuit topology is compared to the original JLH69/96 versions, I have obviously included additional signal/NFB path devices, each one inserting an attendant 90 degrees phase shift, however, loop gain goes through the unity gain floor before their high frequency poles can affect stability.

In spite of me having just written that, do not assume that this or any other JLH class-A amplifier is unconditionally stable. With sensible usage they are, but they are two stage topologies, so there is always a chance

for some unexpectedly high 'Q' and predominantly capacitive loading to induce an oscillatory edginess. This is one reason why I am very wary of using capacitive loudspeaker leads. In the unlikely event that problems arise with a difficult load that cannot itself be corrected, then a series 0.1Ω to 0.22Ω output resistor should be sufficient to overcome any NFB loop induced sensitivity. Actually I have always been unsuccessful in deliberately trying to upset these amplifiers by deliberately shunting their output terminals with different value capacitors whilst they are driving loudspeakers. The high audio frequency response will start to become increasingly dull with values above 1μF, and the capacitor itself might become warm, but the amplifiers themselves run on without problems. I once had to drop a capacitor real sharpish when it so quickly came too hot to hold through me trying this with maximum pop music drive via my original 50W chassis; which still runs to this day, even though looking a little less tidy due to all of the circuit testing it has completed!

When I first powered up my '25-8' prototype and there was no thud, nor any hum, and not any hiss either, not even when I quite literally placed my ear into the efficient test loudspeaker mid-bass cone or right up beside the tweeter phase compensator, I thought that my new construction was not working and that I must have made a wiring error. However when I checked with a test meter both of the output halves proved to be correctly biased, and then a normal mains hum came out of the virtual minus 115dB silence when I touched a meter probe to the input capacitor. What an anticlimax! I went straight from being tensed up and ready for emergency switch-off, into a realisation that it had actually been working from the very first moment it had been switched on. No smoke, no problems to sort out!

This has proved to be a most competent DIY amplifier. Its specifications meet audio requirements, and it recovers from momentary overdrive or overload without fussiness. Also where loudspeakers have been properly designed to accept low impedance drive, this simple amplifier is genuinely capable of making the very best of 15-20W valve designs redundant. Of course there is not much of a 'party-time' sub-bass punch, but it is most satisfying for home use with full-frequency loudspeaker systems.

My twin rail power supply circuits are not regulated either. Each channel has its own (old) 2x 24V-5A

transformer, with a 7A (150A pk) bridge rectifier feeding twin 2x 10mF reservoir capacitors on each rail. I do however also use one 10W 2.2Ω series resistor per rail, each followed by 2x 10mF of smoothing capacitors. That is two resistors, and 8x Panasonic 10mF 'TSUP Series' electrolytics per channel. Do be warned though; these capacitors will retain unloaded charge for weeks, if not months; so do fully discharge them with say a 100 ohm resistor after testing the power supply. Note that my transformers have a 240VA rating for approximately 150W of rectified DC, and although they are air draught cooled they still become quite warm after more than a couple of hours running. When supplying class-A amplifiers, a completely enclosed toroidal transformer should have at least twice, and if possible three times a VA rating for cool running at the VxA power supplied by a directly connected bridge rectifier psu that does not incorporate choke smoothing circuitry.

'Junk Box' parts can be used to try out my figure 10 circuit on a hand drawn and wire linked cardboard pcb, or on stripboard, because a few watts of output is all it takes to prove the worth of a low propagation delay class-A design. Indeed this is an ideal circuit for recycling old industrial or obsolete parts to build a genuinely good amplifier. Early output transistor types will be driven so much more accurately than within the 35 year old circuit, but I could not guarantee their survival at maximum input if the output leads were to be shorted when there are twin power rails, a bootstrapped biasing arrangement and no output capacitor.

If you doubt that my above mentioned low level and microsecond acting filter, C.dom and choke effects can have any impact upon listening, then please do at least show that you have not already been tolerating their induced aberrations, and prove to yourself that your amplifier is indeed as blameless as you had been led to believe it is when driving your own loudspeakers, before assuming from your armchair that I am wrong.

To counter any possible loudspeaker system induced C.dom, output choke and speaker cable effects you first must make a purely resistive load with which to remotely terminate your loudspeaker cables. With 8.2Ω (live) and 0.47Ω (earthy) series resistors replacing your loudspeaker, use the potential developed across the 0.47Ω component as input for my amplifier. Then be prepared to be very surprised by the reproduction differences that your own loudspeaker(s) will reveal as you swap

short leads back and forth between their original connection, and my new amplifier, the latter being driven by no more than your already existing amplifier and its cable-resistor termination. For some who are game enough to try this, maybe the word 'surprise' will turn out to be total understatement, also with your loudspeakers suddenly becoming the better performers they could always have been, but which you never realised was possible! Do not worry about repeatedly turning this amplifier on and off either, it operates as if gated, without the slightest fold-down or recharging thumps.

I consider that this '25-8' pure class-A design does not impart any describable reproduction characteristics; i.e. it is just a plain and ordinary audio amplifier. This said, it might still sound different to other designs, due either to the way in which others might introduce describable phantom errors which result from loudspeaker induced first cycle nuances, or the way in which a particular loudspeaker might be differently cable impedance energised and damped at an individual or over some range of frequencies. Actually it could be said that my finished amplifier is boring, because apart from it maybe lacking in real driving power, there is nothing more to be done other than listen to its output. Unfortunately however, this amplifier is also much more capable than designs which include input filters, Miller C.doms, multi-stage topology and output chokes, at detailedly resolving the flawed processing artefacts of modern CD, DVD-A and SACD mediums. If 'direct cut' DVD-LPCM discs ever do get off the ground, that is digital recording which is unadulterated by dynamic response algorithm controlled compression and expansion processors, then at least this amplifier will not impair their analogue equivalent reproduction integrity.

On-Semi (Motorola) transistors, capacitors etc. are available from Farnell InOne.

For a free CD.rom catalogue phone (UK) 08701 200 200, or search <http://www.farnellinone.co.uk>

Genuine Toshiba transistors and many other components are available from Cricklewood Electronics: phone (UK) 020 8452 0161, or search [www.cricklewoodelectronics.co.uk](http://www.cricklewoodelectronics.co.uk)

*In Part 5 I propose a second amplifier test that may be used with first cycle circuit distortion examinations to predict audio capabilities. I also use it to illustrate the intrinsic value of my simple class-A circuit.*

## atlas LCR

### Passive Component Analyser

**Automatic Identification and Measurement**

**Inductance: 1μH to 10H**  
**Capacitance: 1pF to 10,000μF**  
**Resistance: 1Ω to 2MΩ**  
**Basic accuracy: 1%**

*"Astonishingly, this little unit seems to pack most of the punch of a large and very expensive automated LCR bridge into its tiny case."*

Andy Flind - EPE Magazine



**£79**

fully inclusive UK price

**£60**

fully inclusive UK price

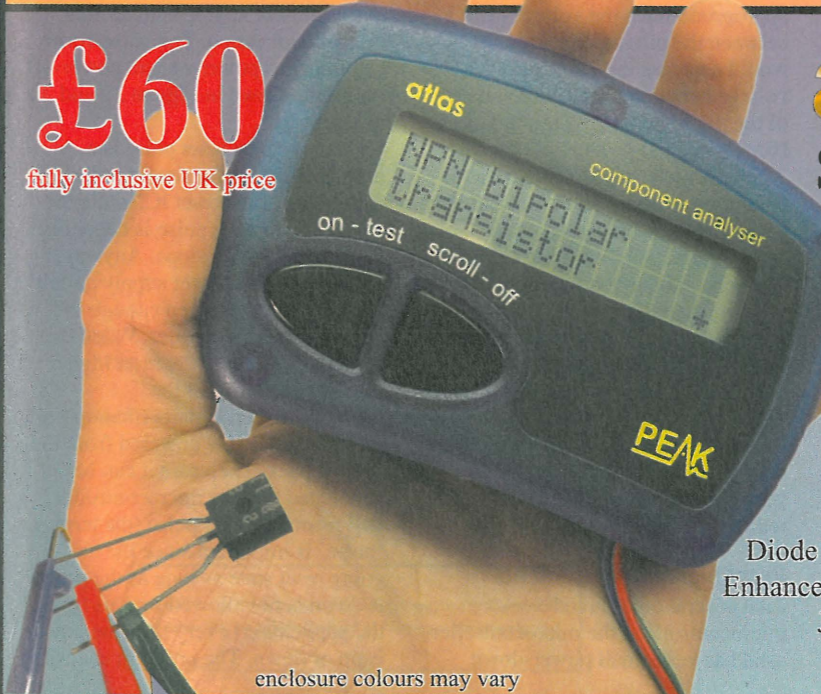

enclosure colours may vary

## atlas DCA

### Semiconductor Analyser

**Automatic Pin-out Identification: Just connect any way round!**

Transistor gain measurement  
MOSFET gate threshold measurement  
PN junction characteristics measurement  
Shorted Junction identification  
Transistor leakage measurement  
Auto power on/off

Bipolar transistors, Darlington transistors,  
Diode protected transistors, Resistor shunted transistors,  
Enhancement mode MOSFETs, Depletion mode MOSFETs,  
Junction FETs, Diodes and diode networks,  
LEDs (+bicolours)

**star pack!**

**£134!**

fully inclusive UK price

**LCR40 and DCA55 Pack**  
**Why not order both analysers in the NEW special edition carry case and save yourself £20!!**

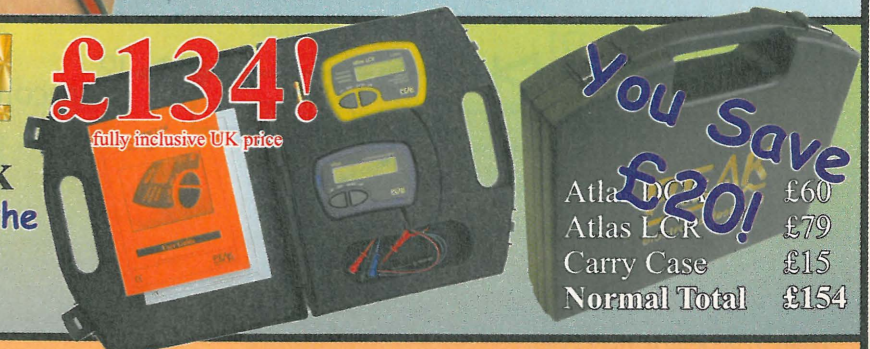

**You Save £20!**

Atlas DCA	£60
Atlas LCR	£79
Carry Case	£15
<b>Normal Total</b>	<b>£154</b>

Visit [www.peakelec.co.uk](http://www.peakelec.co.uk) to download the data sheets, user guides and copies of independent reviews. You can pay using a cheque, postal order, credit or debit card and even pay securely online. Please contact us for your volume requirements.

Also available from Farnell, Maplin, Rapid and CPC (prices vary)

# Making microcontroller RAM non-volatile

Assist. Prof. Dr. Osman Kaan Erol describes a cost-effective way of making some small capacity microcontroller RAM non-volatile

Writing software for the smallest capacity microcontrollers is the other side of the software universe. When compared to big computers, these quantum-sized microcontrollers in contrast have nearly all the necessary peripherals to design a complete system. These peripherals (UART, CAN Bus controller, RF Transmitters, EEPROM, RAM, ...etc) are various but the non-volatile RAM exists only in expensive battery-backed-up micro-controllers. However adding an external memory adds extra costs (hardware and software costs) taking into consideration microcontrollers having only 8 pins and 1K of memory or even less. The proposed method is nearly transparent to the user, making the microcontroller RAM non-volatile, a necessary feature for storing highly varying data storage such as energy data.

## System Description

The problem of having non-volatile memory first appeared to me while designing an energy meter using ATMEL's 89C2051 Flash based 8051 family 20-pin microcontroller<sup>1</sup>. The program memory was already full, and there were difficulties in fitting the code into a 2K memory space. The device was designed so to receive energy pulses from another energy measurement IC, to accept a tariff change signals, be able to communicate via MODBUS, drive six 7-segment LED displays, read an

8 pin address switch and drive three signalling LEDs. Above all, there was no spare program space to fit an interface for a serial EEPROM. At the time of the design, there was no 4K option of the above microcontroller, so it was required to find a way to store the energy registers in the absence of power, that would only consume a few bytes of memory. The microcontroller was designed to operate down to 2V7 which gives the chance to add a three-cell NiMH battery pack in the power line. Non-rechargeable Lithium button cells were not appropriate since the voltage drop between the pins of the diode D3 would decrease the 3V battery voltage below the operating voltage of the microcontroller **Figure 1**. The NiMH cells (3V6 nominal by using 3-cells) were charged using a trickle-charging method<sup>2</sup>. Since this battery is used to back-up the data, fast charging methods were not required. The schematic given in **Figure 1** has no special configuration. With the given schematic, the system is able to operate when the power shuts down but not for a very long time, especially when long term data retention is considered. To prolong the data retention time to beyond a year, some more severe energy reduction themes were necessary.

## Reset Signal Requirements

Like several other brand microcontrollers, the microcontroller used has very small power-down

current consumption, in the order of twenty microamps. The problem was to stop the microcontroller when the power shuts down and to restore to the normal operating state when the power resumes. This problem is resolved without any additional external components. A software algorithm coupled with the reset circuit shown in **Figure 2** is enough to overcome the problem. The reset circuit is given below.

The reset circuit uses a special three-pin reset IC which has positive reset pulse required for this microcontroller. Negative reset pulses are not appropriate for this type of application. The wave-forms belonging to power-on and power-off states are shown in **Figure 3a** and **3b** respectively<sup>3</sup>.

The power-on reset pulse is a normal pulse as mentioned in the datasheets of the reset IC, while the power-down reset pulse is dependent on the voltage fall slope. Anyway, the slope of the power supply circuit at power down is steep enough to reset the microcontroller. When the voltage falls below the reset high-state (active state) of the microcontroller, it starts running the program since it is powered from the battery pack. Therefore it can be concluded that the microcontroller will receive a reset pulse (the term 'pulse' is important since the ongoing reset state as long as the power is down is not allowed for this type of the application) every time the power is up or down. The program checks to

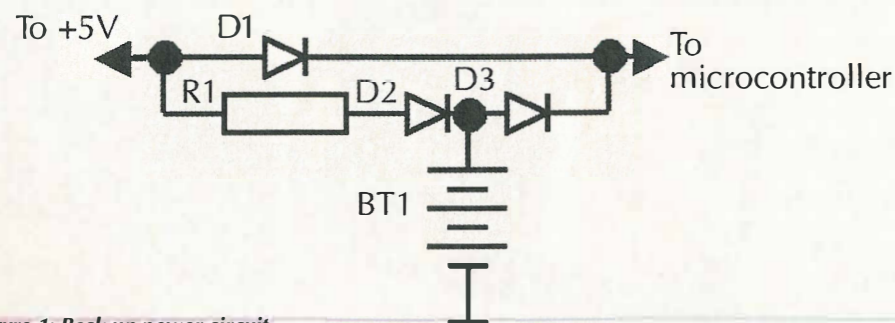

Figure 1: Back-up power circuit.

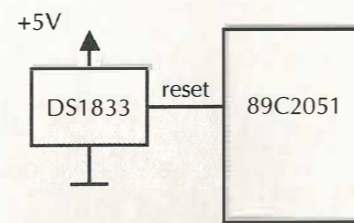

Figure 2: Reset circuit of the microcontroller.

Figure 3: Reset signal waveforms of the DS1833 reset circuit IC

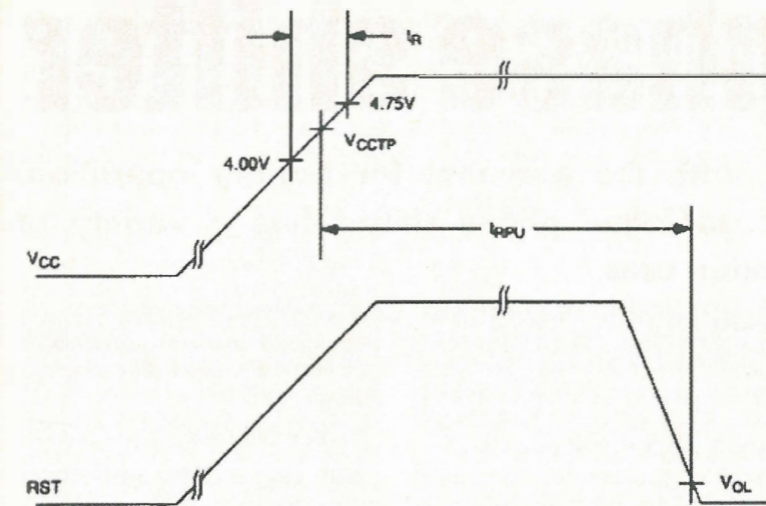

Figure 3a: Power-on reset signal waveform.

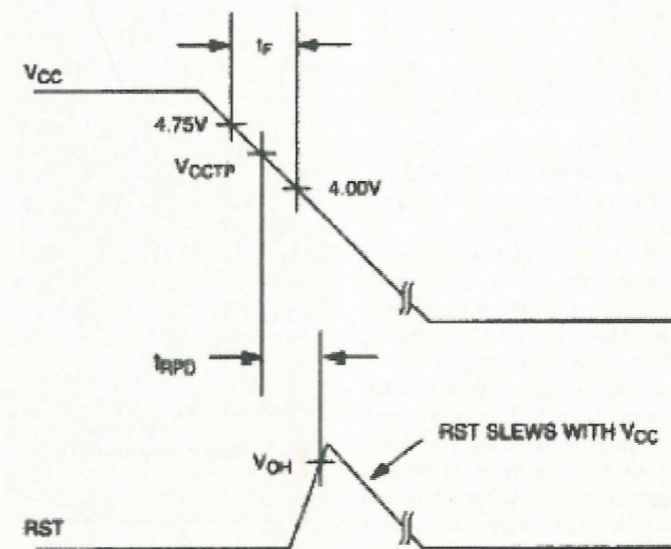

Figure 3b: Power-down reset signal waveform.

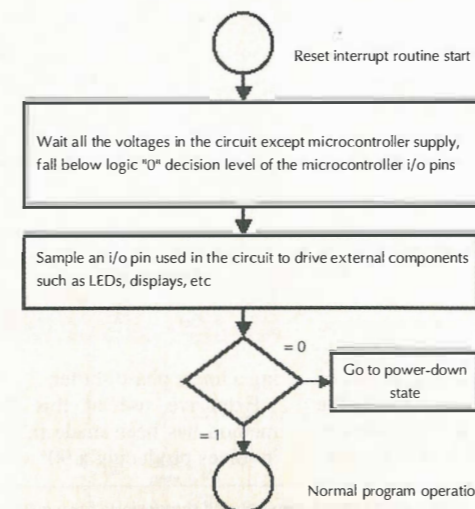

Figure 4: Basic algorithm of the operation

see whether it is a power-on reset or power-down reset. This can easily be accomplished by checking a pin state of the microcontroller normally driven to zero when power is down but can be set to high state when the microcontroller is reset (normally the AT89C2051 puts every i/o pin to high state after reset). The basic algorithm for checking the reset status (up or down) is shown in **Figure 4**.

## The Algorithm

After reset, the microcontroller waits for a predefined delay time to allow all the voltages to fall to zero after power-down. Then it samples the state of a pin whose load characteristics are mentioned in the preceding paragraph. If this is '1' then it is a power-up reset and the program-counter of the microcontroller is loaded with the main program start address. If the pin state is '0', then this means a power-down reset, the microcontroller is put in the power-down state, which reduces its current consumption to below 20µA. This current consumption offers a time retention capacity of more than 1 year depending on the battery capacity (in the application a standard 250mAH button cell battery pack has been used). Since the power will never go down for such a long period of time, this can be considered as long as the battery life. The memory requirement for this application is less than 10 bytes which means this algorithm is quite transparent to the programmer. The necessary memory size can be decreased if a microcontroller having a command size of one word is chosen. Actually 8051 derivatives use commands that spread over more than one byte (2 or 3 bytes are normal).

## Conclusion

The proposed method is well suited for small program memory and highly cost sensitive applications requiring data retention that is nearly transparent to the user. The implementation of the algorithm consumes just a small program memory space.

## References

1. ATMEL 89C2051 datasheet, pages 1-5.
2. Varta V250H NiMH battery datasheet.
3. Dallas Semiconductor, DS 1833 5V Econoreset IC datasheet, page 3.

# Linear phase shifter

Featuring low cost and with the potential for battery operation, Robert Watt's linearised analogue phase shifter has a variety of measurement and calibration uses

## Linear analogue phase shifter specifications

Reference input voltage	1V RMS
Maximum DC input	+40V
Input resistance	1M $\Omega$ , AC coupled
Frequency ranges	10Hz to 100Hz, 100Hz to 1.0kHz and 1.0kHz to 10kHz
Phase-shift range	0° to 90°, 90° to 180°, 180° to 270° and 270° to 360° in four switched quadrants
Phase-shift resolution	0.1°
Phase-shift accuracy	0.1°
Shifted output voltage	varying, 1V to 0.7071V to 1V, depending on output phase angle

## System operating requirements

- Oscilloscope with X/Y amplifiers, sensitivity  $\pm 0.5\text{mV/div}$
- Digital voltmeter - 3.5 digit or better at 1V RMS

Having studied the phase-shiftable signal generator in the July 2000 issue, I thought that you might find the design presented here interesting. This circuit does not have the 16MHz frequency range of the one in the July issue, but it is very inexpensive to build and has computable accuracy.

If necessary, the circuit's 10kHz frequency range can no doubt be

increased by reducing the potentiometer resistance to the limit. Should you do this though, bear in mind the output impedance of the amplifiers.

This design is stand-alone in that it does not need the assistance of a computer. It merely requires a reference sinusoidal input wave and a digital voltmeter.

The circuit has sufficient precision to make it suitable for calibrating other instruments. It can be battery powered, giving it the potential for portability.

Using 10M $\Omega$  scope probes terminated with approximately 50k $\Omega$  resistors, and of course an oscilloscope, the circuit could be used for in-phase measurement of three-phase mains supplies\*.

It can accurately measure the phase shifted by any RC or other network. Alternatively, it can be used to shift the phase of a sinusoidal source from, for example, an oscillator. To my knowledge, there is no other analogue phase shifter with this linearity and precision that is currently available.

## The circuit's origins

This concept was developed some 30 years ago while I was employed by Ferranti Ltd and is long overdue for publication.

A patent was never applied because the principle was shown mathematically many years before this by a chap called Drysdale. At that time, implementing the circuit was impossible, although the circuit is a very simple method of producing a linear phase shifter.

## List 1. Corrected and uncorrected results obtained from the Qbasic program, List 2.

### Result 1 Corrected

Dial	Deg	Mins	V0
0	0	0	1
5	4	58	.9234656
10	9	58	.8635239
15	14	59	.8166017
20	20	0	.7801611
25	25	1	.7523797
30	30	2	.7319505
35	35	2	.7179568
40	40	1	.7097911
45	45	0	.7071068
50	49	59	.7097911
55	54	58	.7179566
60	59	58	.7319503
65	64	59	.7523793
70	70	0	.7801607
75	75	1	.8166011
80	80	2	.8635231
85	85	2	.9234646
90	90	0	.9999987

### Result 2 Uncorrected

Dial	Deg	Mins	V0
0	0	0	1
5	3	22	.946077
10	7	8	.8958065
15	11	19	.8498366
20	15	57	.8089012
25	21	2	.7737994
30	26	34	.7453561
35	32	28	.7243559
40	38	40	.7114583
45	45	0	.7071068
50	51	20	.7114582
55	57	32	.7243557
60	63	26	.7453558
65	68	58	.7737991
70	74	3	.8089007
75	78	41	.8498361
80	82	52	.8958058
85	86	38	.9460762
90	90	0	.9999992

Extensive use of this phase-shift method has been made in the past. It involves producing a 90° vector equal

\* Specialist knowledge of the safety requirements and regulations for working with anything involving mains voltages is mandatory due to their potentially lethal nature.

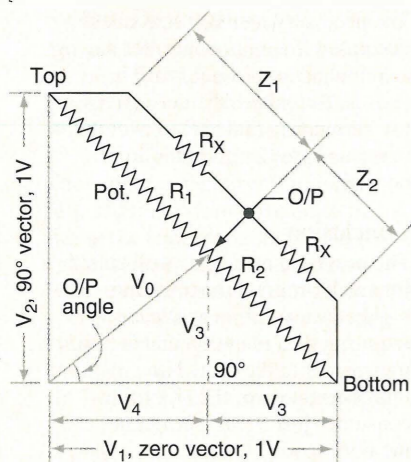

Figure 1. Vectors involved in the potentiometer and compensation resistor combination.

in size to the input vector and then connecting a potentiometer between the input and 90° vectors. The potentiometer wiper position represents a vector output from the input phase to 90°.

The problem with this method is that the output is not linear so a modification to the circuit has been developed. This modification is very simple; connect a resistor of 1.8025 times the total value of the potentiometer from the wiper to each end of the potentiometer, Figure 1.

As the calculation results in List 1 show, the errors before correction are approximately 4° maximum and after correction are less than 2 minutes over the entire potentiometer range.

## Generating a 90° vector

To achieve a 90° vector, the frequency range switch in the circuit involved here selects a suitable capacitor, which

is connected in series with a potentiometer marked frequency balance. This series combination is connected between the 'zero' and 180° vectors.

Now, the balance potentiometer is adjusted for the frequency involved. When the voltage across the capacitor is equal to that across the balance potentiometer then the vector at the junction of the two is 90° and is unity in size.

## Circuit requirements

Figure 2 is a practical circuit, producing phase shift from 0 to 360° with an overall accuracy of  $\pm 0.1^\circ$  and a frequency range of 10Hz to 10kHz.

As the phase potentiometer can only shift up to one quadrant, the vector polarities require manipulating to shift around the circle; a 'quadrant switch' achieves this. To enable resolution to

0.1°, a ten-turn helical potentiometer with an appropriate dial is required.

Due to stray capacitance along the length of the potentiometer, maintaining  $\pm 0.1^\circ$  accuracy at 10kHz requires a potentiometer of as low a value as practical. A value of 1k $\Omega$  with a linearity of  $\pm 0.02\%$  such as a Beckman model 'A' is suitable.

For the dial to display the output in degrees, the potentiometer must travel ten turns to the dial's nine turns. This requires the dial coupling to be made via a 9:10 gear assembly.

To produce an accurate 90° vector, a DVM is alternately connected between the 90° vector and the zero and 180° vectors in turn, by the setting of the balance switch. The frequency-balance potentiometer is then adjusted for equal readings on the DVM for each setting of the balance switch. This adjustment

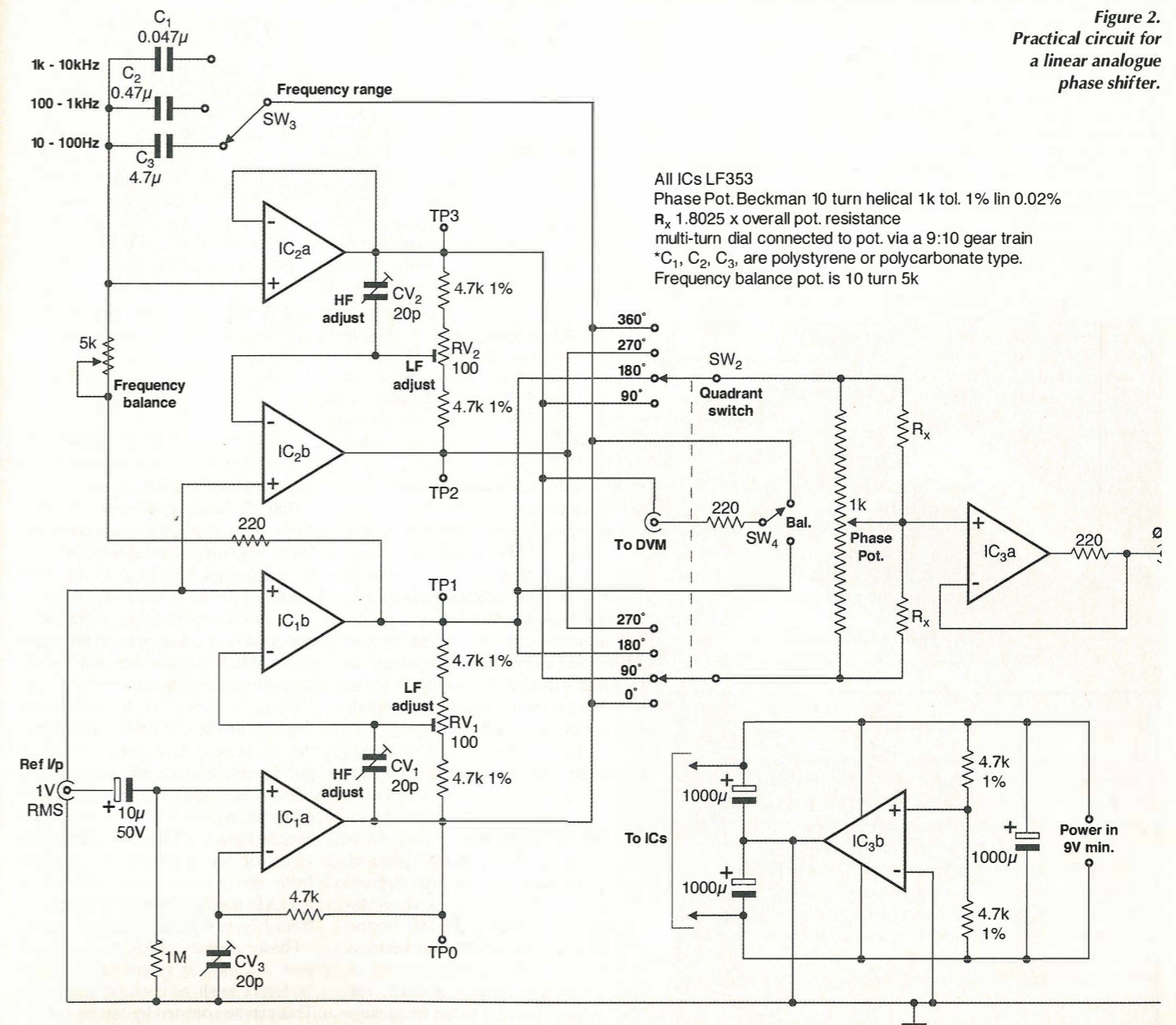

Figure 2. Practical circuit for a linear analogue phase shifter.

All ICs LF353  
Phase Pot. Beckman 10 turn helical 1k tol. 1% lin 0.02%  
R<sub>x</sub> 1.8025 x overall pot. resistance  
multi-turn dial connected to pot. via a 9:10 gear train  
\*C<sub>1</sub>, C<sub>2</sub>, C<sub>3</sub> are polystyrene or polycarbonate type.  
Frequency balance pot. is 10 turn 5k

List 2. Qbasic listing for verifying the linearity of the corrected phase-shifting arrangement.

```

REM QBASIC
CLS: N = 0
REM PHASE
PRINT "X IS THE RATIO, COMPENSATING RESISTOR/POT. "
PRINT "REQUIRED TO LINEARISE THE POT. FOR PHASE SHIFT"
PRINT "C IS THE DIAL SETTING OF THE POT."
PRINT "R1 IS THE FRACTION OF THE POT. FROM TOP TO THE WIPER"
PRINT "R2 IS THE FRACTION OF THE POT. FROM WIPER TO BOTTOM"
PRINT "IF THE 0 DEG. AND 90 DEG. VECTORS ARE 1VOLT "
PRINT "THEN THE VOLTAGE VT ACROSS THE POT. IS 1.4142VOLTS"
PRINT "THE O/P VECTOR V0 IS A FUNCTION OF THE O/P ANGLE "
FL = 0: FLAG = 0: FLAG1 = 0: FLAG2 = 0
DIM A$(20), B$(20), C$(20), D$(20)
AGAIN:
PRINT "DO YOU WISH A HARD COPY Y/N": INPUT FL$
IF FL$ = "Y" OR FL$ = "y" THEN FL = 1: GOTO FIRST.IN
IF FL$ = "N" OR FL$ = "n" THEN GOTO FIRST.IN ELSE GOTO AGAIN
FIRST.IN:
CLS : GOSUB CORRECTED
INPUT.NEW:
PRINT "DIAL", "DEG", "MINS", "OUTPUT VOLTS"
IF FL = 1 THEN LPRINT "DIAL", "DEG", "MINS", "OUTPUT VOLTS"
C = 0
FOR Count = 1 TO 0 STEP -.0555555
R1 = Count
R2 = 1 - R1
REM PYTHAGORUS
V1 = 1: V2 = 1: VT = SQR((V1 ^ 2) + (V2 ^ 2))
REM CAN'T DIVIDE BY ZERO
IF R1 = 0 THEN Z1 = 0
IF R1 > 0 THEN Z1 = (R1 * X) / (R1 + X)
IF R2 = 0 THEN Z2 = 0
IF R2 > 0 THEN Z2 = (R2 * X) / (R2 + X)
ZT = Z1 + Z2: I = VT / ZT: VZ2 = I * Z2
REM PYTHAGORUS AGAIN
V3 = SQR(VZ2 ^ 2 / 2)
V4 = V1 - V3
V0 = SQR((V3 ^ 2) + (V4 ^ 2))
REM TANGENT AND CAN'T DIVIDE BY ZERO
IF V4 = 0 THEN T = 1.57
IF V4 > 0 THEN T = V3 / V4
REM RADIANS
R = ATN(T)
ANGLE = R * 180 / 3.14159: DEG = INT(ANGLE): MINS =
CINT((ANGLE - DEG) * 60)
IF MINS = 60 THEN MINS = 0: DEG = DEG + 1
PRINT C, DEG, MINS, V0
IF FL = 1 THEN LPRINT C, DEG, MINS, V0
A$(N) = C: B$(N) = DEG: C$(N) = MINS: D$(N) = V0
C = C + 5: N = N + 1
NEXT
N = 0
IF FLAG = 1 THEN PRINT "STORE? Y/N": INPUT FL1$
IF FL1$ = "Y" OR FL1$ = "y" THEN GOSUB FILE2
PAGE 10.
IF FL1$ = "N" OR FL1$ = "n" THEN FLAG = 2
IF FLAG = 2 THEN END
STORE:
PRINT "STORE? Y/N": INPUT FL$
IF FL$ = "Y" OR FL$ = "y" THEN GOSUB FILE1
IF FL$ = "N" OR FL$ = "n" THEN GOTO MORE
MORE:
PRINT "MORE? Y/N": INPUT MORE$
IF MORE$ = "N" OR MORE$ = "n" THEN END
IF MORE$ = "Y" OR MORE$ = "y" THEN GOSUB UNCORRECTED ELSE
GOTO MORE
GOTO INPUT.NEW
END
CORRECTED:
IF FL = 1 THEN LPRINT "CORRECTED"
X = 1.8025: PRINT "CORRECTED": RETURN
UNCORRECTED:
IF FL = 1 THEN LPRINT "UNCORRECTED"
FLAG = 1: X = 999999999: CLS : PRINT "UNCORRECTED": RETURN
FILE1:
OPEN "A:\RESULT1.BAS" FOR OUTPUT AS #1
CLS
PRINT "STORED VALUES"
PRINT #1, "CORRECTED"
PRINT "DIAL", "DEG", "MINS", "V0 "
PRINT #1, "DIAL", "DEG", "MINS", "V0"
FOR Q = 0 TO 18
PRINT #1, CSNG(A$(Q)), CSNG(B$(Q)), CSNG(C$(Q)), CSNG(D$(Q))
PRINT CSNG(A$(Q)), CSNG(B$(Q)), CSNG(C$(Q)), CSNG(D$(Q))
NEXT Q
CLOSE #1
RETURN
FILE2:
OPEN "A:\RESULT2.BAS" FOR OUTPUT AS #2
CLS
PRINT "STORED VALUES"
PRINT #2, "UNCORRECTED"
PRINT "DIAL", "DEG", "MINS", "V0"
PRINT #2, "DIAL", "DEG", "MINS", "V0"
FOR Q = 0 TO 18
PRINT #2, CSNG(A$(Q)), CSNG(B$(Q)), CSNG(C$(Q)), CSNG(D$(Q))
PRINT CSNG(A$(Q)), CSNG(B$(Q)), CSNG(C$(Q)), CSNG(D$(Q))
NEXT Q
FLAG = 2
CLOSE #2
RETURN
END

```

must be carried out for each test frequency used.

The balance potentiometer is labelled frequency balance and is adjusted in conjunction with the frequency range switch for the frequency in use.

**Operating the circuit**

Measurement of an unknown wave-

**Measuring an unknown waveform**

To measure an unknown waveform, apply approximately 1V RMS to the shifter reference input at the desired test frequency. Connect a DVM to the DVM socket and adjust the frequency balance potentiometer to equalise the DVM readings to  $\pm 1$  millivolt for both positions of the balance switch. The shifter is now operational at this test frequency. Set the quadrant switch to the expected quadrant. Connect one oscilloscope probe to the shifter output and the other probe to the unknown waveform and adjust the shifter dial and quadrant switch for a diagonal scope display. The shifter quadrant switch plus the phase dial give the unknown phase with respect to the reference.

form can be achieved by comparing the shifter output to the unknown wave using an oscilloscope set for X/Y display pattern and DC coupled.

If the test frequency is greater than 1kHz then the oscilloscope X and Y channels require phase balancing. This can be accommodated by using x10 probes and connecting both probes to the same waveform, then adjusting the frequency compensation capacitors of the probes for a diagonal display.

Sensitivity of the X and Y channels should be adjusted to allow 0.1° resolution.

**Circuit description**

Reference input amplifier IC<sub>1a</sub> is a x1 buffer. Its output is the zero degrees vector and is fed to IC<sub>1b</sub> - a x1 reversing amplifier producing the 180° vector.

In addition, the zero degrees vector is fed to the frequency range switch, which selects the range capacitor. The 180° vector connects to the frequency-

balance potentiometer.

Both the junction of the range capacitor and the balance potentiometer are fed to IC<sub>2a</sub> which produces the 90° vector and is input to IC<sub>2b</sub>. A x1 reversing amplifier produces the 270° vector.

All four vectors connect to the quadrant switch, allowing the output potentiometer to be switched around the circle, one quadrant at a time.

Phase accuracy of the 90° vector depends on the loss or power factor of the capacitors C<sub>1-3</sub>; polystyrene or polycarbonate types are suitable.

The output potentiometer is phase corrected by the resistors marked R<sub>X</sub>; each has a value 1.8025 times the total value of the potentiometer. Output from the potentiometer feeds IC<sub>3a</sub>, which is a x1 buffer amplifier. Output from IC<sub>3a</sub> is the phase-shifted output.

Phase accuracy of IC<sub>2a</sub> and IC<sub>2b</sub> outputs, i.e. the 90° vector and the 270° vector, depends on the input frequency. This can be adjusted by setting the fre-

Figure 3. Arrangement for determining the voltage across C.

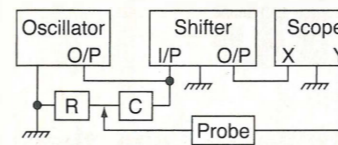
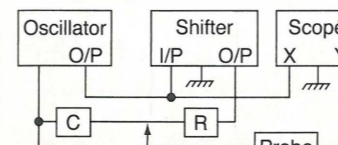

Figure 4. Determining the voltage across C.



quency range switch, connecting a DVM reading volts to the DVM socket and adjusting the frequency balance potentiometer to balance  $\pm 0.1\%$  the DVM reading. Do this for both positions of the balance switch.

Power consumption of the circuit is quite low, at less than 20mA, so battery operation and portability are both options. The function of IC<sub>3b</sub> is to divide the power source into two lines about the ground plain, removing the need for two batteries.

The minimum usable battery required is 9V, giving a  $\pm 4.5V$  supply to the ICs.

**Adjusting the amplifiers**

**Low frequency adjustment.** Input approximately 1V RMS at 400Hz to the REF socket. Using the DVM, measure the output of IC<sub>1a</sub> at TP<sub>0</sub> then move the DVM to TP<sub>1</sub> and adjust RV<sub>1</sub> for the reading at TP<sub>0</sub>  $\pm 0.5mV$ .

Next, move the DVM to TP<sub>2</sub> and measure the output of IC<sub>2a</sub>. Move the DVM to TP<sub>3</sub> and adjust RV<sub>2</sub> for the DVM reading obtained at TP<sub>2</sub>  $\pm 0.5mV$ .

**High frequency adjustment.**

To perform HF balancing of the oscilloscope, input 10kHz at 1V RMS to the REF socket. Connect both scope X and Y channels via x10 probes to the REF socket, set both channels to 5mV/cm and X/Y display.

If the display is an ellipse then adjust one or both probe compensation capacitors until a diagonal is achieved, this compensates the HF unbalance in the scope amplifiers.

Now move one of the probes to

the TP<sub>0</sub> and adjust CV<sub>3</sub> for a diagonal line. Next move the probe at the REF input to TP<sub>1</sub> and adjust CV<sub>1</sub> for a diagonal line.

Move the probes, TP<sub>0</sub> to TP<sub>2</sub> and TP<sub>1</sub> to TP<sub>3</sub>, adjust CV<sub>2</sub> for a diagonal line. The circuit is now operational.

**Calibration**

Checking the accuracy of the shifter is difficult without sophisticated equipment. However, a method of checking at various points on the dial can be achieved. Select a resistor and quality capacitor, measure the component values and calculate the phase angle of their series connection for the selected frequency.

Use an oscilloscope as described under the heading 'Measuring an unknown waveform' to make the following tests.

Set your test generator accurately to the test frequency and apply to both the shifter input and to the capacitor of the series connected components.

Compare the angle across the resistor to the shifter output as in Figure 3. Any number of angles may be checked by altering the test component values.

The quality of the test capacitor becomes more important as the test frequency is increased. Values of the resistor and capacitor should be such that they will not be compromised by the connection of a x10 scope probe. Note that if the voltage across the resistor is compared to the shifter output, then the output will be in the first quadrant and gives one point on the shifter dial.

Turn the test components upside down, so that the voltage across the capacitor is compared. Connect the output of the shifter to the input of the resistor as in Figure 4. In this connection, the output of the shifter is added to the capacitor angle to finally give a zero angle on the display and the shifter dial again is in the first quadrant.

Adding the angles across the resistor and across the capacitor will give 90° and the addition of the shifter dial readings should agree to this  $\pm 0.1^\circ$  if the system is perfect. As the readings are in the same quadrant, then the errors will add together. As a result, the errors should be halved for the correct answer.

The test resistor and capacitor are best selected to give angles of approximately 65° and 25°. These angles check the system at about its worst points. ■

Has this copy of

**ELECTRONICS WORLD**

been around the circuit more than a couple of times?

**Subscribe!**

Delivered to your door before it hits the shops...

**Be the first to read it!**

**Call**

**01353 654431**

Highbury Fulfilment Services, Link House, 8 Bartholomew's Walk, Ely Cambridge, CB7 4ZD.



# TV 'pong' game

Many years ago before home computers or mobile phones there appeared an arcade tennis game called 'Pong' everyone thought at the time this was the last word in interactive gaming. Put on your flares and afro wigs as John Morrison revives a golden oldie

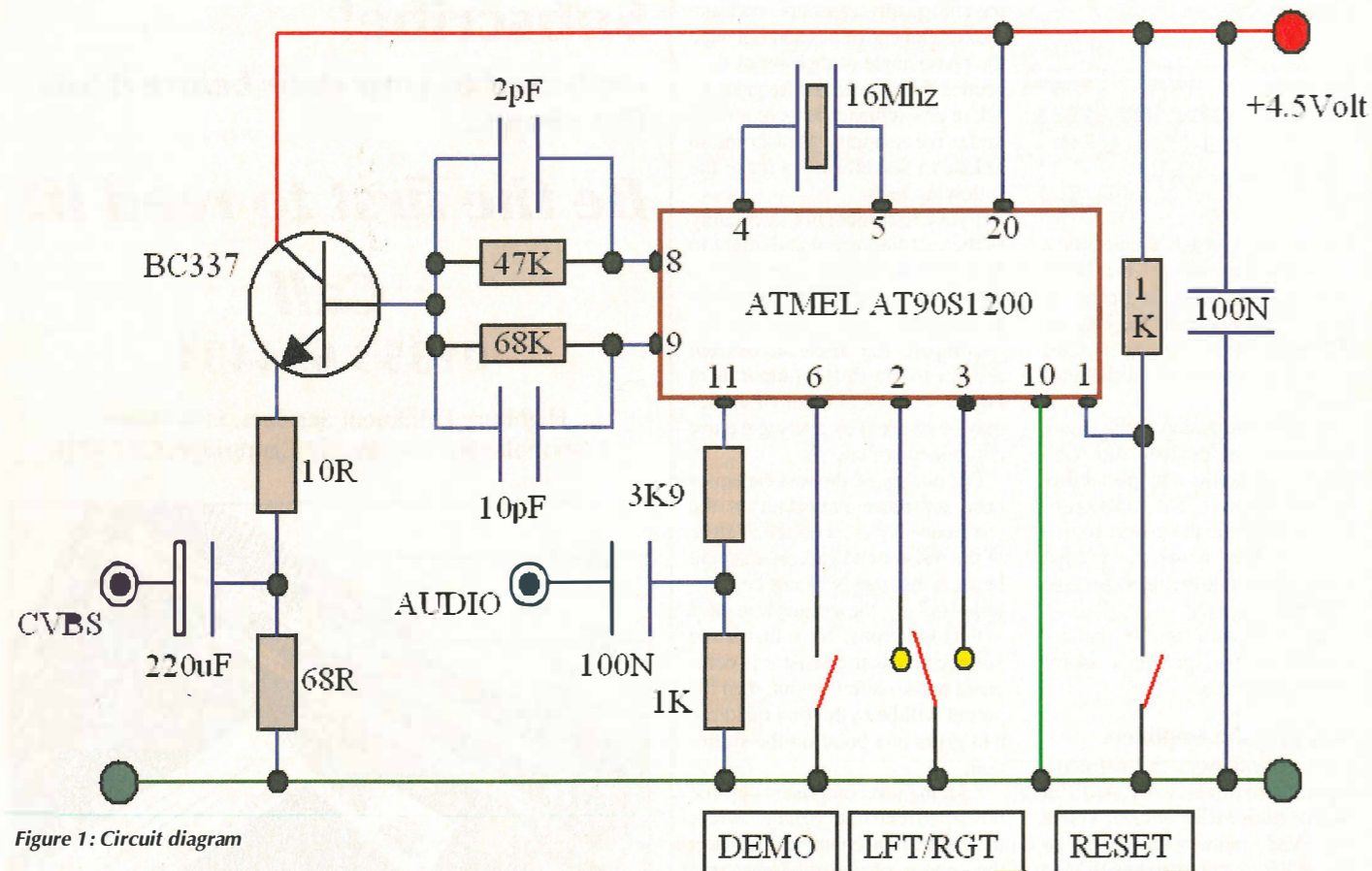

Figure 1: Circuit diagram

Being a keen electronics buff, I thought of making one of these games for myself, so I set about building it using TTL logic gates. It took about three months and 40 or so ICs and had to be powered from a 5 amp supply.

Once built, my son and I spent many happy hours playing with it. My son, now thirty, had been talking about the gadgets I keep making and mentioned the pong game, old hat now but still fun to play. This set me thinking about whether it would be possible to make one using modern components, perhaps a micro controller. This is the result.

The unit can be built using an Atmel 90S1200/1300 micro controller and little else. I have added

more features than the original unit and it can be built on a 5cm x 2.7cm PCB using standard components. The controller is programmed to supply CVBS video out with sound and will connect directly to a TV scart socket.

The game has on screen scoring, a ball, centre net and two bats - both of which can be computer controlled for a demo mode where it plays itself. The source listing is easy to customise. You could add balls, change the bat sizes, alter the speed and more.

### Micro-controller

The Atmel 1200/1300 controller is fast, one instruction takes only 62.5ns. It is also very cheap and easy to obtain. It has flash re-

programmable code memory of 1024 bytes and 64 bytes flash data memory.

The code and data memory can be 'locked' to prevent unauthorised access.

There is an on chip analog comparator and an internal oscillator (4MHz) so an external xtal may not be required in some projects. The reset pin can be tied to V<sub>cc</sub> for 'reset on power up'.

### How it works

A video picture is made up from 25 frames a second each frame consisting of 2 fields of 312.5 lines per field making 625 lines in total. Each line is 64µs long consisting of a 4.7µs horizontal line sync pulse

Figure 2: AT90S1200 pin out

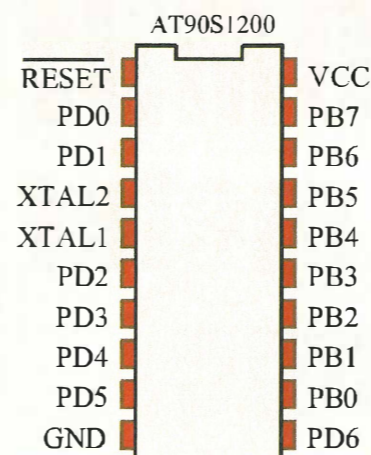
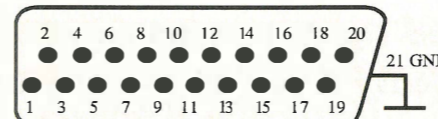

Figure 4: Scart socket



### Components

R1 10R	C1 220µF 6volt
R2 68R	C2 2pF
R3 47k	C3 10pF
R4 68k	C4 100nF
R5 3k9	C5 100nF
R6 1k	XT1 16MHz Xtal
R7 1k	TR1 BC337 or similar
IC1	AT90S1200 or 1300

You can obtain a free assembler and lots of information on Atmel products from [www.atmel.com](http://www.atmel.com)

Readers who are building the project and need the listing, please email Caroline Fisher (details on page 3) with A133 as the subject

within a 12ms blanking period and 52ms of visible picture per line. The Atmel 90S1200 can easily generate the video sync signals required.

The controller operates in Timer Interrupt mode to generate these signals which is still too fast and must be divided down to obtain the required line frequency. The code within the interrupt is therefore time dependant and should not be altered. A 16 bit counter is incremented every time an interrupt is taken and is used to determine which displayed line we are on. There is also an Hsync flag which is cleared at the end of each interrupt. We use this to determine when a new line is about to start.

The screen objects, bats and ball, are moved during each field blanking

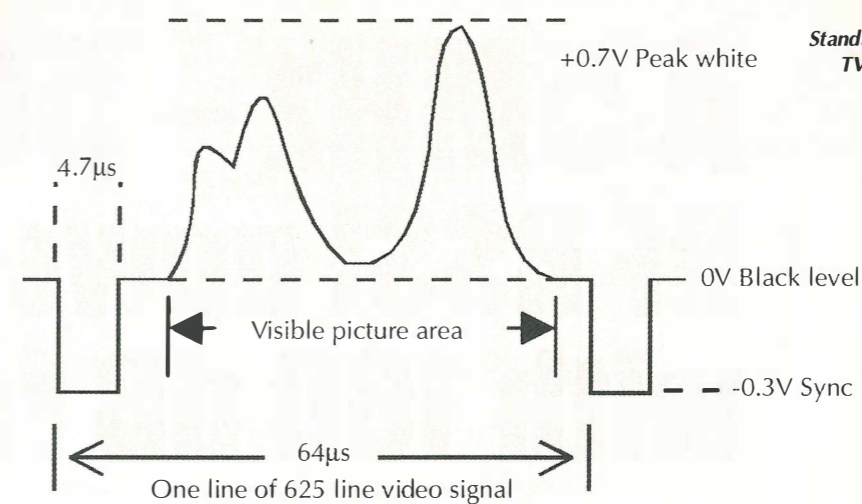

Figure 3: Standard 625/50 TV waveform

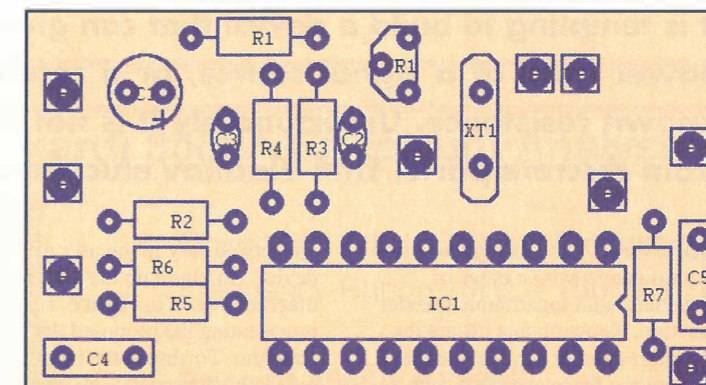

Figure 5: PCB component side

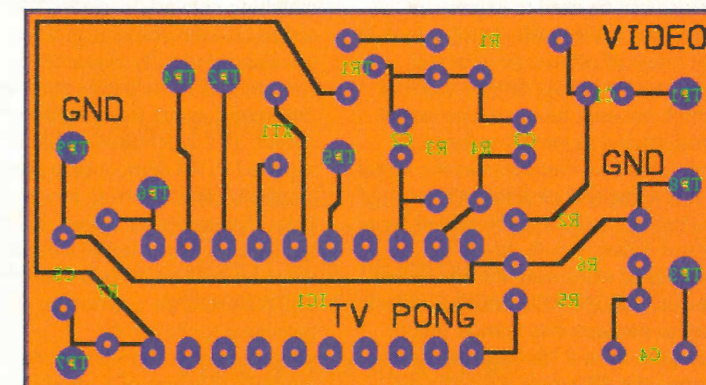

Figure 6: PCB print side

PCB not to scale. Scale to size 5cm x 2.7cm

# A 5MHz – 500MHz RF RSSI power meter with 100 dB range

It is tempting to build a device that can give you information about the power level of a signal source, or a received signal terminated in a known resistance. Unfortunately it is not so easy if you try to build it from discrete parts. Emil Vladkov elucidates

I discovered that Analog Devices is producing a whole range of devices with logarithmic transfer function. Knowing that dB are the log-expression of a value, the idea was not too far fetched that such a device can be used to express an electrical value in dB. I took a look at the range of offered devices and came across the AD8309 – a device which not only has a voltage output proportional to the dB-value of an input, but also demodulates the signal – it is some sort of detector<sup>1</sup>.

That's exactly what is needed for a power meter, which should be capable of measuring the equivalent power of a CW RF-source<sup>6</sup>. The task was to measure this voltage and to compute from it (through the slope factor) the dB-value. Also this dB-value needs to be displayed in some

convenient way to the user of the device. So I built up the system diagram shown in **Figure 1** representing the proposed device structure. To absorb the input power on a known resistance an input matching network is needed<sup>8</sup>. It serves also the conversion from unbalanced to fully balanced signal at the input, as the AD8309 operates in differential mode from input to output. The differential signal is supplied to the demodulating log amplifier for converting power-to-volts. The analogue output of the log amplifier is converted to a digital value by a 12-bit A-to-D converter. The results of the conversion are presented to the device microcontroller through a serial SPI-interface. The use of a serial interface is a right choice in the case of

implementing microcontrollers with low pin counts, which have not enough I/O-lines to handle parallel interfaces to converters. The parallel interface is used to connect the micro to the data bus of an alphanumeric 2 rows x 8 digits display for presentation of the results. An additional three lines are needed to control the transfer of information from and to the display device. The use of a microcontroller has the additional benefit of providing a serial RS-232 interface making easy interfacing and transfer of data to a PC possible. The power supply needs are rather complicated, as all digital logic and the log amp use a 5V regulated supply, but the A-to-D converter I implemented needs 2.5V to provide a dynamic range from 0V to 2.5V which is exactly the output range of the log amplifier.

Lets dive in with some details regarding the internals and working of the different subcircuits building the whole device.

## Basic principle of operation of a logarithmic amplifier

The main purpose of the basic logarithmic amplifier is to produce an output signal, which is proportional to the logarithm (usually at base 10) of the input signal. So the circuit can reduce a very wide dynamic range of a signal (as in the described implementation – 100dB) to a much convenient one to handle and interpret decibel value. The transfer function of the logarithmic amplifier can be described by the equation (1)<sup>1</sup>.

Figure 1: Block diagram of the RSSM8309 RSSI power meter

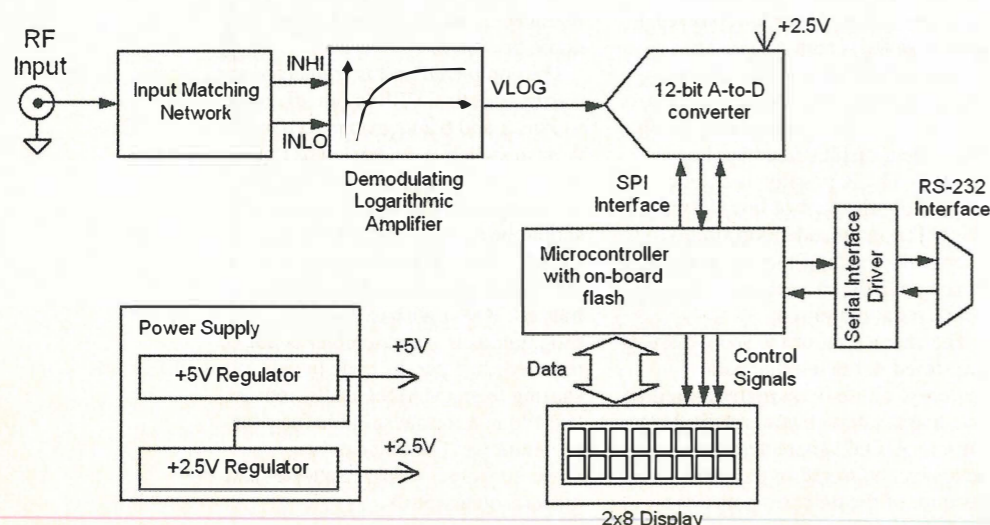

# TELNET

Special Offers of  
Quality Second  
User Test Equipment



## Agilent (Hewlett Packard) 8753D Network Analyser



Option 11 (This deletes the 'S' Parameter)  
85046A 'S' Parameter Test Set can be purchased separately if required.  
Frequency Range 300kHz – 3GHz  
Up to 110 dB of Dynamic Range

Price of 8753D = £7995  
Price of 8753D + 85046A = £9995

## Agilent (Hewlett Packard) 3588A Spectrum Analyser



Option 001 (High Stability Frequency Ref.)  
Frequency Range 10Hz – 150MHz

Price of 3588A = £3995

## Fluke / Philips PM97 Scopemeter



50 MHz (25 Megasamples / Second) Dual Trace  
DSO Integrated Dual Channel 5000 count  
True R.M.S. Multimeter.  
Complete with all accessories and Carry Case.

Price of PM 97 = £400

## Stanford Research DG535



Four Channel Digital Delay Generator  
Various options available  
Two Fully Defined Pulse Outputs  
5 picosecond Edge Resolution  
50 picosecond RMS Jitter  
Fully Adjustable Amplitude & Offset  
Delays up to 1000 seconds  
1 MHz Maximum Trigger Rate  
Internal, Burst, Line or External Triggering  
GPIB Interface – Standard  
Optional Outputs + or – 35V, 100 ps Rise / Fall  
Price of DG535 = £2750

All equipment is used – with 90 days guarantee.  
Packing/Delivery and VAT to be added to all goods.  
TELNET, 1 Stoney Court, Hotchkiss Way,  
Binley Industrial Estate  
Coventry CV3 2RL ENGLAND

Tel: 02476 650 702  
Fax: 02476 650 773  
Web: [www.telnet.uk.com](http://www.telnet.uk.com)  
Email: [sales@telnet.uk.com](mailto:sales@telnet.uk.com)

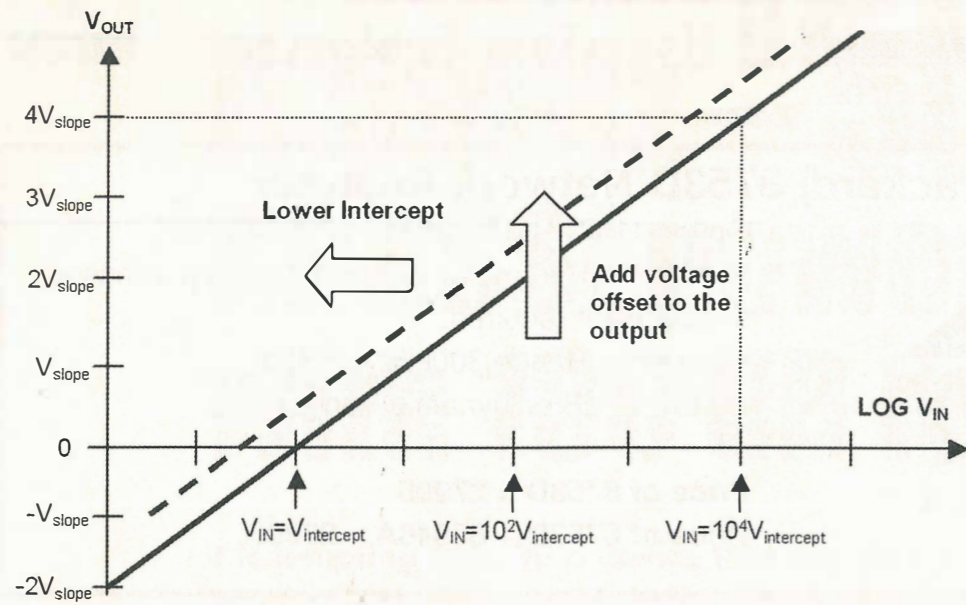

Figure 2: Logarithmic amplifier transfer function without/with lowered intercept voltage

$$(1) V_{OUT} = V_{slope} \cdot \log_{10}(V_{IN}/V_{intercept})$$

$V_{IN}$  and  $V_{OUT}$  are the input and output voltages,  $V_{slope}$  is the so-called 'slope voltage' and  $V_{intercept}$  is the 'intercept voltage'. It is obvious that the slope voltage represents the slope of the transfer function as depicted in Figure 2<sup>1</sup>. From the same diagram the meaning of the intercept voltage can be derived – it is the input voltage at which the output of the logarithmic amplifier passes through zero. In real world implementations of a logarithmic amplifier a shift voltage is added to the output, which results in the dotted line transfer function in Figure 2. In this way the intercept voltage is

lowered, so positive output voltages (convenient in single supply implementations) are obtained for smaller input signals. This is equivalent to a gain ahead of the input – so the input signal is amplified and smaller RF signals can be measured. This is a very simple way of amplifying a signal – simple addition of a voltage shift to the output.

To obtain the exact logarithmic transfer function an amplifier with an infinite gain under small-signal conditions would be required. For a wideband log amplifier this means many cascaded gain cells of normal gain and high bandwidth. This is equivalent to a large gain-bandwidth product (GBW) – for the AD8309 it

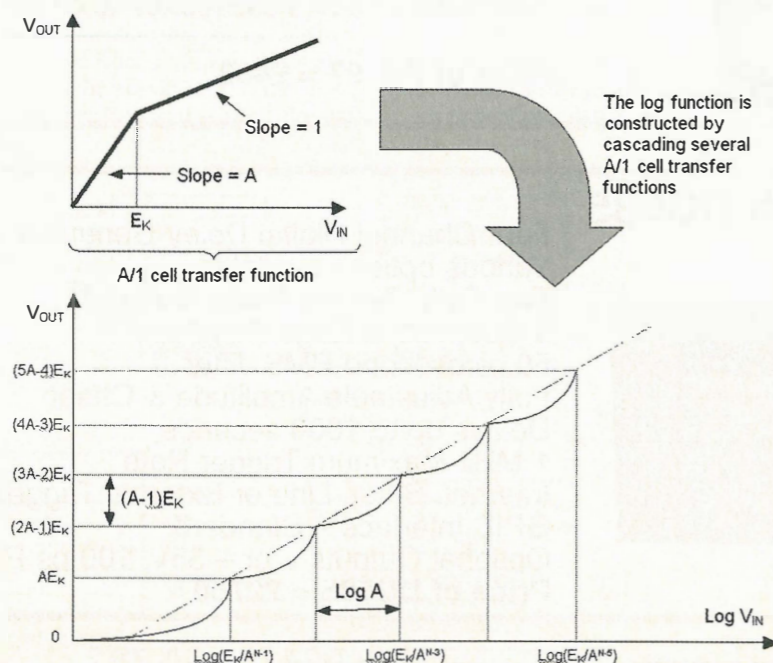

Figure 3: Constructing the log transfer functions from A/1 cells

is nearly 52,500GHz, which is enormous. The bad news is that even a small amount of noise will lead to output voltage, so signals below certain levels of the noise floor cannot be measured. The responsibility of the designer is to ensure that the noise baseline is below and not above the intercept point. The described logarithmic amplifier will use a cascade of non-linear gain stages. Each non-linear amplifier unit has a piece-wise-linear transfer function as is depicted in Figure 3. Often it is called A/1 cell. For small signals the gain is A, but after a certain point ( $E_K$ ) it drops to unity gain. For the classic (non-demodulating) log amplifier the same function is symmetrical and valid for both positive and negative input voltages. Usually the intercept voltage and the slope voltage can be expressed in terms of the parameter  $E_K$ .

As it is obvious from the second diagram in Figure 3, as the input of the first cell reaches the value of  $E_K/A^{N-1}$  the input to the  $N^{th}$  cell reaches the knee voltage  $E_K$  and the last ( $N^{th}$ ) stage transforms its gain from A to 1 (it does not contribute to the gain for further increase in input). As the input rises sequentially the stages in the log amplifier go from gain A to gain 1. For large input voltages the cascaded stages have no gain at all. So the log function is approximated in a piece-wise linear matter and the second diagram in Figure 3 illustrates this approximation. It should be mentioned that the X-axis has a log-scale, so the approximation is to a straight line. From the diagram we can derive the slope voltage parameter and the intercept voltage stated in (2)<sup>1</sup>.

$$(2) V_{slope} = \frac{(A-1) \cdot E_K}{\log_{10} A}, \quad V_{intercept} = \frac{E_K}{A^{(N+1)/(A-1)}}$$

Of course the intercept voltage in this case of cascaded amplifiers is an approximation only, as the output can be zero only for zero input in the case of normal amplifiers.

### Principle of operation of a demodulating logarithmic amplifier

The AD8309 used in the proposed design is a demodulating amplifier, which means that it responds not to the actual input RF signal but to the envelope<sup>7</sup>. And the envelope is what is obtained after a demodulation. Such a log amplifier can give you information about the dB-voltage or power of the signal. The demodulating amplifiers use different

Table 1: Correction factors for the intercept voltage for different kind of signals

Signal Type	Correction factor (add to output reading)
Sine	0dB
Square wave or DC-voltage	-3.01dB
Triangular wave	+0.9dB
GSM channel (all timeslots on)	+0.55dB
CDMA channel	+3.55dB
PDC channel (all timeslots on)	+0.58dB
Gaussian noise	+2.51dB

kinds of cells – the so-called A/0 cells. In the case of the A/0 stage the gain falls to zero above the knee voltage  $E_K$ , so every stage acts as a limiter. The logarithmic output is generated not by cascading the cells, but by summing their outputs. In the most cases summing is done on the currents  $I_{OUT}$  of every stage in a summing amp and I/V converter.

The intercept voltage is identical to that given by (2). The slope voltage is somewhat different and is expressed by (3)<sup>1</sup>.

$$(3) V_{slope} = \frac{A \cdot E_K}{\log_{10} A}$$

Usually the A/0 cell is constructed as a very simple bipolar-transistor differential pair with a large signal transfer function as shown in Figure 4 with the dotted line. The solid line is the ideal transfer function of an A/0 cell. The  $\tanh$  function of the practical implementation of the A/0 cell has the advantage, in comparison to the ideal one, of lowering the ripple as the individual A/0 segments are seamed together. The internal structure of the described kind of log amp (demodulating) is shown in the lower diagram in Figure 4 and is implemented in the AD8309 used in the project. The whole amplifier chain is differential from input to output. The output of the stages (not the current for the RSSI, which is the logarithmic output) is hard limited, so such a log amp can be used to recover FM and PM signals. The differential path of the signal makes it less susceptible to supply line disturbances, supply voltage and temperature variations. The major difference between the logarithmic and the demodulating logarithmic amplifier is that in the last one the alternating input is converted to a DC-voltage through rectification. The AD8309 uses a full-wave rectifier for this purpose.

The widespread way of describing a RF-input is as equivalent power in dBm, but in this case it is important to state the impedance at which this power is applied. Usually as in the case of this project the impedance is

50 $\Omega$ , which means that 0dBm applied power (relative to 1mW, what the 'm' in dBm means) corresponds to a sine wave with a 316.2mV amplitude. If a RF-signal with known waveform (and crest factor to compute the RMS-voltage) is concerned the expression from (4) can be used to compute the dBm-value of input power in 50 $\Omega$  load.

$$(4) Input\_Power[dBm] = 10 \cdot \log \left[ \frac{U_{rms}^2}{50} \frac{1}{1mW} \right]$$

It should be noted that every logarithmic amplifier responds to voltage, not power. So sometimes the input is specified in dBV, which means a sine wave with a rms-value of 1V for 0dBV. Also it is worth mentioning that the intercept voltage is a function of the waveform, so if you are measuring power you need to know the form of the signal and add respective correction factors to the

output reading. Usually it is not a problem, as actual measurements are performed on signals of known shape (like GSM time-slot channels) and the device will be rarely used to measure integrated sources power. If the user knows that the signal is white noise (Gaussian distribution), then he/she can add corresponding correction values. The correction values which should be added to the output reading on the display for known RF-signals waveforms are given in Table 1<sup>1,7</sup>.

The log amp used (the AD8309) has an extremely wide dynamic range (nearly 100dB). The noise floor which determines the lower end of the dynamic range is -78dBm, so the device I'm discussing can measure all signals above this level. The experiment shows that a realistic -74dBm can be obtained, but not the proposed -78dBm, as the input can not be so well isolated from the printed circuit board noise sources. The upper end of the dynamic range is nearly +22dBm (which is an amplitude of 4V sine into 50 $\Omega$ ) and is covered by the addition of four other detectors (transconductance stages  $g_m$  like these in Figure 4) connected after attenuator chains. The exact structure of the AD8309 is shown in Figure 5. The backbone of the device is the chain of six A/0 cells, everyone with the gain of 12.4dB and 850MHz bandwidth. The input (INHI and INLO) is differential exactly as the output of the limiter

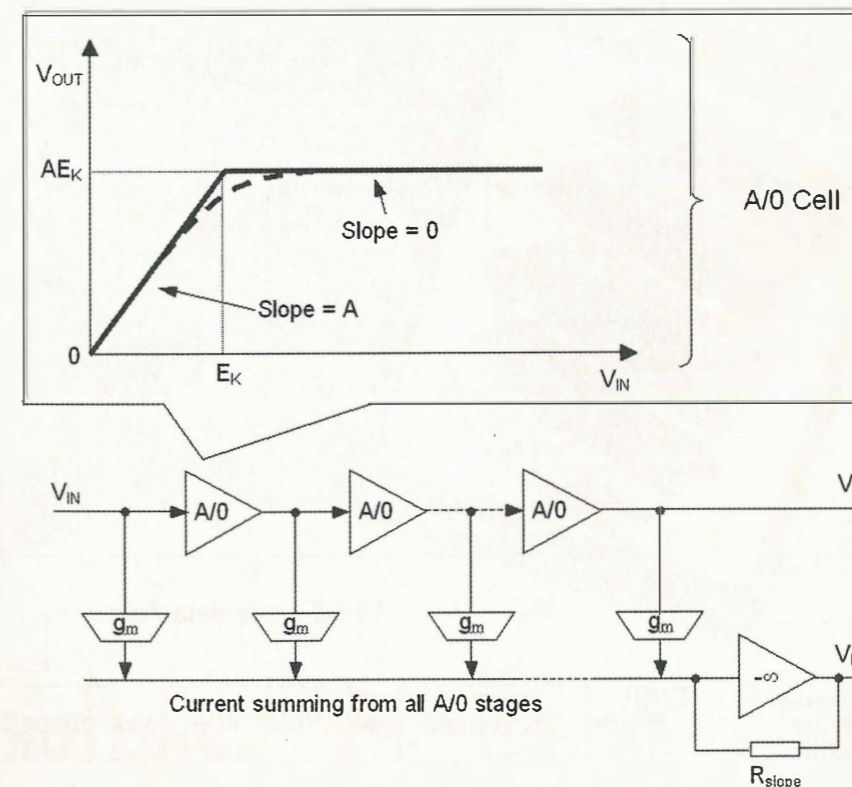

Figure 4: Demodulating logarithmic amp cell transfer function and internal structure



(LMHI and LMLO). The limiter stage, which is the last one in the chain of amplifier/limiter subcells, has a gain of 18dB. The limiter drive programming pin LMDR and the limiter outputs are not used in the proposed design, but are very useful for demodulation purposes in receiver applications. The six gain cells and the corresponding detectors handle the lower part of the dynamic range. For the upper part of the dynamic range they are responsible with the four additional full-wave detectors tapped at 12dB spacing to the passive attenuator at the input of the chain. There are two references on chip – one for the gain of the cells and one for the slope. A temperature compensation is placed at the current-to-voltage converter. The VLOG-output, which is the logarithmic output, has as slope of 20mV/dB with this arrangement. The conformance to the log-law is within the margins  $\pm 0.4$ dB worst case, which is sufficient for a measurement device such as described here<sup>1</sup>. The RSSI-output swings between 0.34V and 2.34V with a 5V supply voltage.

#### The analogue-to-digital Converter AD7476

I decided to use a 12-bit A-to-D converter with serial high-speed interface (SPI) because of the limited number of I/O lines of the microcontroller used – the 89C2051<sup>4</sup>. The choice has fallen on the Analog Devices AD7476, which has the advantage of being a very small

package (SOT-23) and low in power<sup>2</sup>. The converter has a fast throughput rate – 1MSPS. This high rate is not needed in a conversion of slow varying voltages to be displayed for viewing on a LCD, but I accepted it because of the other useful features of the device. The 12-bit resolution needs to be argued. Let's make some simple calculations. The dB-value of input power will be presented on the display in 0.01dB resolution. With a slope voltage of 20mV/dB to obtain this resolution a 0.2mV resolution of the analogue-to-digital converter is needed. The 12-bit converter is hardly suitable to fulfil this requirement, but a 14-bit converter will be unnecessary if the noise sources on the PCB and the slope error of the logarithmic amplifier are taken into account. So we can assume the 12-bits of the AD7476 are just right to fulfil the task.

The AD7476 has three digital lines to interface to the microcontroller – these are the Serial Clock SCLK, the Serial Data SDATA and the Chip Select CS. The SCLK provides the serial clock for the successive approximation conversion process of the ADC and for accessing data from the part. The SDATA is the serial data stream output. The data is clocked out from the AD7476 on the falling edge of SCLK. 16 bits are clocked for every conversion result – 4 leading zeros and 12 bits of conversion data with the MSB provided first. The CS signal has the dual function of initiating a

conversion and framing the serial data transfer. The timing diagrams for the conversion or serial data access of the AD7476 are shown in Figure 6. The interrelations of the three signals have to be followed exactly by the microcontroller (which is governed by the microcontroller firmware code) to provide the right interface to the converter. The conversion commences on the falling edge of the CS signal. As the ADC can go into power-down mode (which is not implemented in the design as the power consumption is low enough even for battery powered operation), there should be provided at least ten consecutive SCLK cycles before the CS goes high again – this ensures the device remains fully powered up. The conversion is completed within 16 clock cycles. At the same time data is clocked out on subsequent SCLK falling edges. The first leading zero of the result is provided on the falling edge of CS. So the first falling edge of SCLK clocks out the second leading zero. The last bit of the conversion has been clocked out on the 15th falling edge and is valid on the 16th falling edge. All these specific timing relations in reading the result of the conversion are strictly followed by the device code of the microcontroller, so they are given only for completeness of the design presentation. The reader does not have to worry about it – the source and the object code are available from the EW office by emailing

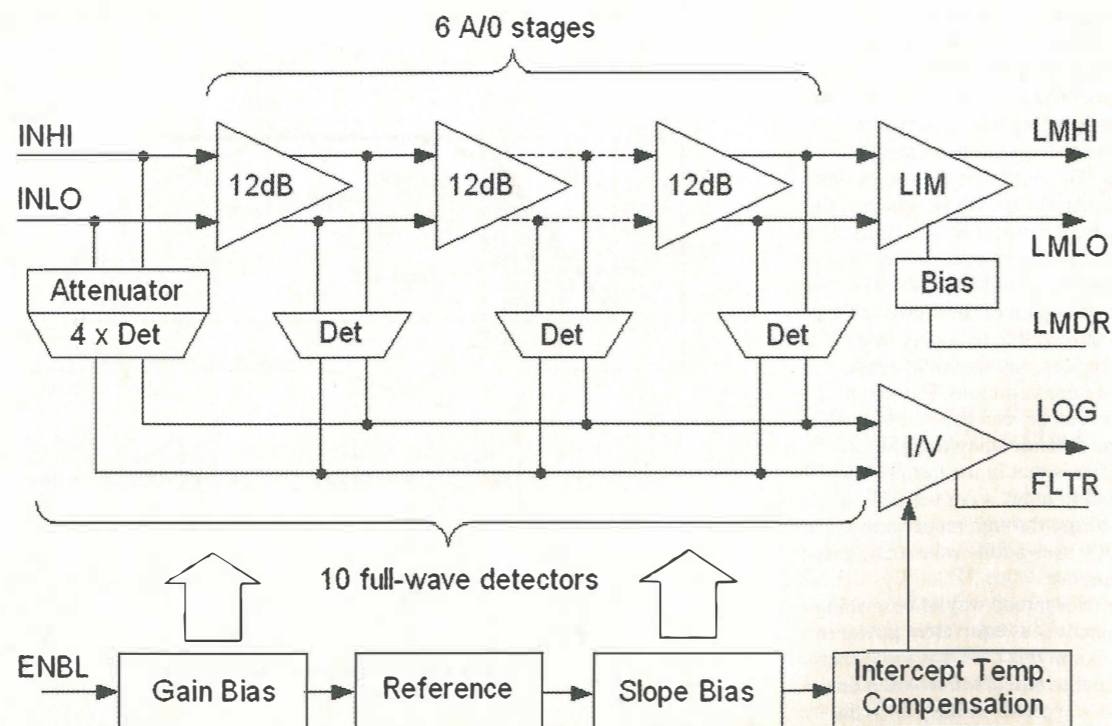

Figure 5: Internal structure of the AD8309 demodulating amplifier

# OLSON®

# UK's NO.1 IEC CONNECTION



CALL OUR SALES HOTLINE  
**020 8905 7273**



24 HOUR DELIVERY SERVICE

OLSON ELECTRONICS LIMITED  
 OLSON HOUSE, 490 HONEYPOT LANE, STANMORE, MIDDX HA7 1JX  
 TEL: 020 8905 7273 FAX: 020 8952 1232  
 e-mail: sales@olson.co.uk web site: http://www.olson.co.uk

GB 1907

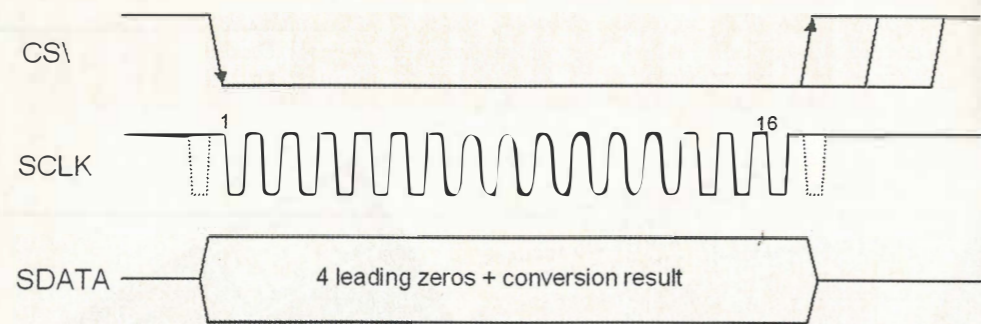

**Figure 6:** Normal mode of operation of the A-to-D converter timing diagrams

Caroline Fisher (details page 3) with 'A 122' as the subject. For the analogue part of this integrated circuit it should be mentioned that no external voltage reference is required because the AD7476 derives its reference voltage from its power supply making the widest dynamic range possible. The input voltages allowed for the ADC range from 0V to VDD. So to make full advantage of the dynamic range of the device the VDD for the ADC is lowered to stabilised (through a special low-power regulator) +2.5V. The RSSI-output between 0.34V and 2.34V fits perfectly in this dynamic range.

#### Detailed circuit diagram of the RSSM 8309 device

The complete circuit schematic diagram is provided in Figure 7 on page 36. The RF input is applied on connector J1 with the input-matching network, consisting of C<sub>4</sub>, C<sub>5</sub>, R<sub>3</sub> and L<sub>1</sub>. It should be mentioned that the resistor R<sub>3</sub> is not exactly the 50Ω needed for matching to the input line, because it is connected in parallel with the input resistance of the U<sub>1</sub> logarithmic amplifier AD8309. This input resistance is approximately 1kΩ, so that the parallel combination gives exactly 50Ω. The L<sub>1</sub> 4.7nH inductor provides for flat impedance response to about 1GHz. If you do not intend to use the circuit with such wideband signals the L<sub>1</sub> can be omitted and replaced by a short circuit jumper on the PCB. As the limiter output is not needed in the proposed application the associated pins are not used or tied to the supply line – LMDR is left unconnected and the outputs LMHI and LMLO are tied to the VPS2 supply line. A good ground plane should be used with this design and decoupling capacitors are provided on the two supply pins VPS1 and VPS2 – these are capacitors C<sub>1</sub> and C<sub>2</sub>. The power supply resistors R<sub>1</sub> and R<sub>2</sub> provide additional decoupling of the power supply to the log amp. The four pins PADL are connected directly to the metallic lead frame connected to the

back of the chip, which is fabricated as silicon on insulator. To provide proper shielding of the internals of the circuit, the paddle pins must be connected with the shortest possible path to the ground plane of the circuit. The capacitor C<sub>3</sub> is provided for filtering the logarithmic output voltage and reduces the RSSI output bandwidth from the nominal 3.5MHz to a lower value (below 10Hz with the 10mF capacitor value) so that measuring and displaying the input power without continuous changing lower digits is possible. An unpolarised type capacitor should be used, or in the case of an electrolytic capacitor, the positive terminal should be connected to the FLTR-pin. The AD8309 is continuously enabled by tying the Enable Signal (ENBL) to the positive filtered (C<sub>7</sub>) supply line.

The Received Signal Strength Indicator (RSSI) output at the VLOG-pin of U<sub>1</sub> IC is tied directly to the analogue-to-digital converter U<sub>2</sub> (the AD7476 discussed earlier in the article). As the ADC derives its reference from the supply line proper filtering is necessary and is accomplished with the addition of the C<sub>16</sub> and C<sub>17</sub> components directly at the IC's case. The supply voltage of the converter is set to 2.5V to provide full dynamic range of capturing the RSSI output. This supply is ensured by the U<sub>4</sub> precision voltage reference – the AD1582<sup>3</sup>. The primary supply for this voltage regulator is the on-board +5V supply filtered by capacitors C<sub>15</sub>, C<sub>18</sub> and C<sub>24</sub>. The digital interface of the ADC to the microcontroller U<sub>3</sub> (an AT89C2051<sup>4</sup>) is covered with three of the micros I/O pins – P3.3, P3.4 and P3.5. P3.4 and P3.5 are driving only this integrated circuit (the ADC) but the use of the P3.3 line connected to the SDATA output of the converter demands some explanation. The same line P3.3 is used as output from the microcontroller to drive the Register Select (RS) signal of the LC display. At the same time the P3.3 line acts as input for the ADC data. How is it

possible? The trick is that the SDATA output is active only when accessing the converter, otherwise it is tristated. The microcontroller combines the tasks of external devices accesses with time division, so when it accesses the ADC it does not access the display, so it reads the P3.3 line as input (at this time the SDATA output of the converter is activated). When the display is accessed the CSV-input of the ADC is high, so SDATA is tristated; at the same time the micro drives the P3.3 line in accordance with the display configuration protocol.

The microcontroller is reset by the RC circuit R<sub>4</sub>-C<sub>10</sub> and the clock frequency is set by the components X<sub>1</sub>, C<sub>8</sub> and C<sub>9</sub>. The dB-information regarding the RF-signal input power is output on the J2 device. Although it is stated that the device is a PC802-A type, every type of 2x8 LC display will do the job, as their interface is standard<sup>5</sup>. This standard interface includes the Register Select (RS), the Read/Write (R/W), the Enable (E) signals and the 8-bit data bus DB7-DB0, connected to the P1 port of the microcontroller. If the display device has the option of a backlight, the R<sub>6</sub> current limiting resistor should be installed, otherwise it can be omitted. As the display is an STN-type (and not TFT) the contrast is determined by the components R<sub>5</sub> and P<sub>1</sub>.

The 89C2051 microcontroller has a built-in serial interface. To complete the RS-232 interface the U<sub>5</sub> serial line driver is needed with the associated components C<sub>11</sub>, C<sub>12</sub>, C<sub>13</sub> and C<sub>14</sub>. The RS-232 interface is presented on the J<sub>3</sub> DB9 female connector. The main regulated power supply (+5V) for most of the circuits is provided by U<sub>6</sub> the 7805 3-terminal regulator with the associated components C<sub>19</sub>, C<sub>20</sub> and C<sub>21</sub>. The whole device's power consumption is so low that a micropower +5V regulator can be used. For my own I used the normal TO-220 device without any heatsink, ensuring the optimal thermal conditions. The input DC voltage between 9V and 12V is fed to the J<sub>4</sub> power supply connector and the diode D<sub>1</sub> protects the circuit from applying the wrong reverse voltage. Normal operation of the device is indicated by the power supply LED D<sub>2</sub> and the current limiting resistor R<sub>7</sub>.

#### Making some practical measurements

It was interesting and challenging not only to build the RSSM 8309 RSS power meter but also to check out its correct operation. I used all available

devices and instruments at hand, which could provide accurate (and known shape) output levels or could influence some known RF power source in a predictive manner. So the accuracy of the device build could be checked without the expense of calibrating it with £100K+ instruments. The experimental set-up I used is shown in Figure 8. The MAX038-based function generator can provide three waveform shapes up to more than 16MHz – sine, triangle and square. It is very stable as the amplitude and the power developed on the 50Ω load can be easily calculated and represents the theoretical value to compare with the RSSM 8309 readings. I programmed the generator to produce exactly  $f_{gen}=10,000\text{MHz}$ , which is within the measurement range of the proposed device.

For the sine wave output (crest factor = 1) I received the following results:  
 $U_{ampl} = 0.460\text{V}$ ,  $U_{rms} = 0.325\text{V}$  that gives according to (4):  $P_{theory} = 3.26\text{dBm}$

Power, measured with the RSSM 8309:  $P_{experimental} = 3.21\text{dBm}$ .

For the triangle wave output (crest factor = 1.732) the following results were obtained:  
 $U_{ampl} = 0.460\text{V}$ ,  $U_{rms} = 0.266\text{V}$  that gives according to (4):  $P_{theory} = 1.49\text{dBm}$

Power, measured with the RSSM 8309:  $P_{experimental} = 0.89\text{dBm}$ , when applying the correction factor from Table 1:

$P_{experimental} = 0.89\text{dBm} + 0.9\text{dBm} = 1.79\text{dBm}$

We observe a good coincidence of the theory and the experimental results especially for the sine wave input. The small deviation from the predicted value for the triangular waveform can be explained by the non-ideal parameters of the triangle voltage. Even small changes in the shape have great impact on the power measured, so I assume the RSSM 8309 is measuring the real situation which differs from the ideal one used in computing the theoretical power.

With this part of the experiment the absolute accuracy of the device has been evaluated. The next part of the work is to measure the relative accuracy. It's much harder to find many accurate RF-power sources with amplitudes covering the enormous range of 100dB, but it is easy to use one accurate source at fixed power level and then implement a variable attenuator/amplifier to produce relative (in dB) readings on the device under test (DUT). The experimental set-up uses the

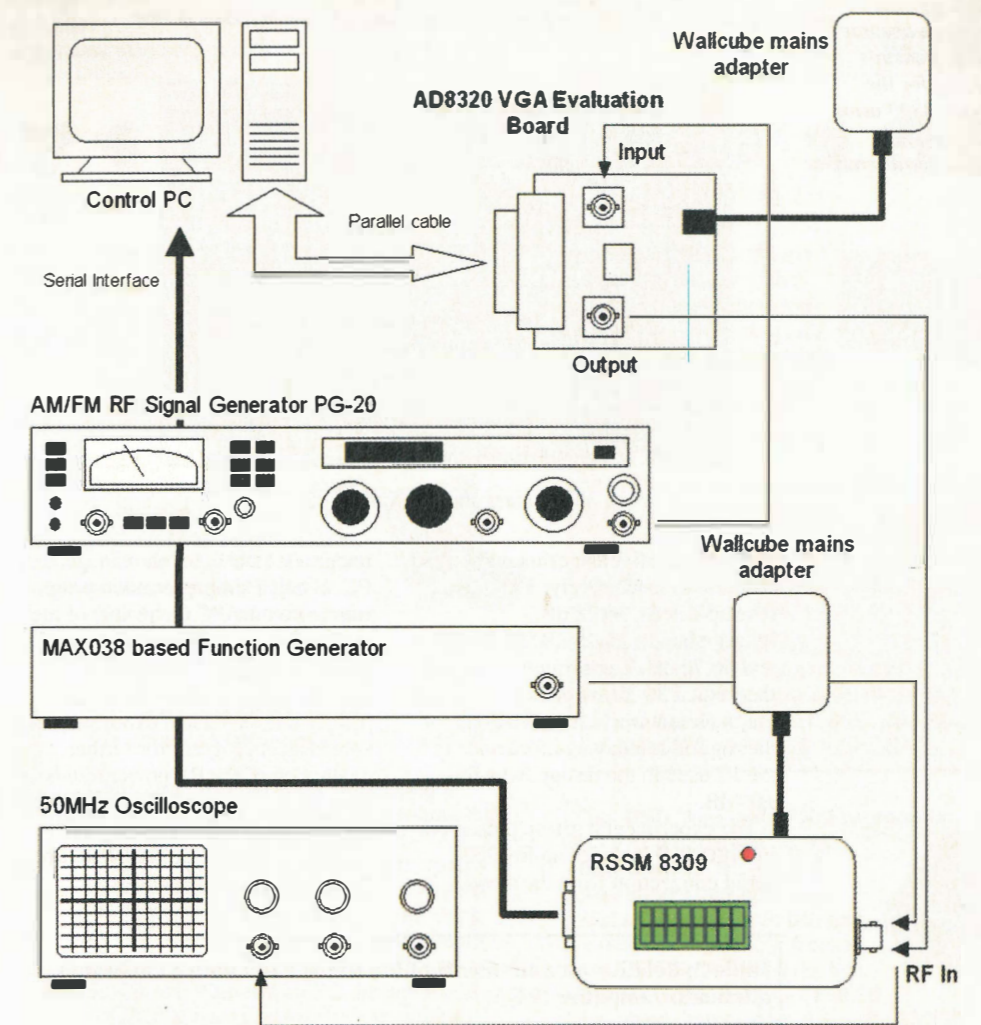

**Figure 8:** Experimental setup for calibrating the accuracy of the RSS power meter

configuration shown also in Figure 8. The source of the RF-signal at a frequency of 15MHz is the AM/FM signal generator PG-20. Its output is connected to the input of the AD8320 Evaluation Board (Variable Gain Amplifier/Attenuator with a range from -10dB to +25.99dB). The modified amplitude output from the evaluation board supplies the input of the RSSM 8309 with signal. The variable attenuator around the AD8320 is very simply configured with a user interface provided by Analog Devices through a PC connected via a parallel port to the board. The gain/attenuation settings for the VGA are given in the first column of Table 2. The RF-signal generator used has different output power ranges and I have used five of them, differing in attenuation with 10dB one from each other. The results are given in the five columns of Table 2, expressing the exact readings of the device under test (the RSSM 8309). The five relatively shifted measurements across the whole range of the attenuator make possible the evaluation of the behaviour of the RSS power meter

across its approximately full usable range.

It is evident that for the first two columns with experimental results the last values (above 10dBm) are not available (NA). This is not due to limitations of the power meter RSSM 8309, which can measure till +22dBm, but because the variable attenuator/attenuator limits its output for such large values – it is not intended to be fed with large RF power levels and to work as an amplifier with great gain at the same time. Therefore the results above the mentioned +10dBm are not accurate with this experimental set-up (including the AD8320 VGA evaluation board).

The graphical representation of the relative experimental results is presented in Figure 9. The perfect parallelism of all lines (Series 1: Range 0-10 till Series 5: Range 40-50) validates the good accuracy of the RSSM 8309 across the central 60dB range. When we look in detail at the results in Table 2 we can see that for 36dB full range of the programmable amplifier/attenuator the measured full scale (attenuator)

Figure 9: Relative accuracy measurements results for the RSSM 8309 using a calibrated amplifier/attenuator

Relative Measurements of the RSSM 8309

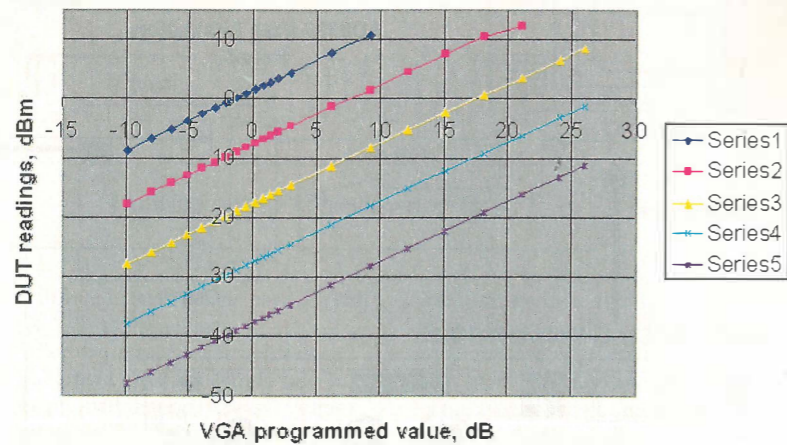

range for the five experimental columns is respectively: 36.83 dB (extrapolated), 36.38 dB (extrapolated), 36.46 dB, 36.74 dB and 36.70 dB. The difference with the theoretical 36 dB range is well within the manufacturer's specifications for the logarithmic law conformance of the IC used in the design, which is  $\pm 0.4$ dB.

The experimental set-up presented in Figure 8 includes an RS-232 serial connection from the device

under test (DUT) to the management PC. Using a simple terminal program running on the PC the results of the measurements of the received RF power changing twice per sec approximately can be viewed as history and saved and exported to a spreadsheet program for further evaluation of the RF power trends over time. The format of the simple ASCII-characters messages is: PWR -74.04 + Carriage Return + Line Feed (example value).

Table 2: Relative Measurements of the RSSM 8309 with a calibrated attenuator/amplifier (VGA)

VGA value, dB	Power measured for different RF signal generator ranges (relative), dBm				
	0-10	10-20	20-30	30-40	40-50
-10.00	-8.70	-17.83	-27.81	-37.95	-47.96
-8.11	-6.65	-15.81	-25.83	-35.96	-46.10
-6.56	-5.00	-14.19	-24.21	-34.34	-44.45
-5.24	-3.63	-12.91	-22.83	-32.94	-43.08
-4.10	-2.44	-11.72	-21.61	-31.69	-41.89
-3.09	-1.43	-10.71	-20.57	-30.62	-40.82
-2.19	-0.54	-9.80	-19.60	-29.70	-39.90
-1.37	0.25	-8.94	-18.77	-28.85	-39.08
-0.62	0.95	-8.15	-17.95	-28.05	-38.31
0.07	1.66	-7.44	-17.25	-27.35	-37.61
0.71	2.30	-6.77	-16.60	-26.68	-36.97
1.30	2.88	-6.16	-15.99	-26.10	-36.36
1.86	3.46	-5.58	-15.41	-25.52	-35.75
2.88	4.50	-4.54	-14.41	-24.51	-34.71
6.05	7.91	1.31	-11.17	-21.15	-31.35
9.11	10.85	1.56	-8.12	-18.01	-28.21
12.06	NA	4.56	-5.06	-15.02	-25.21
15.00	NA	7.55	-2.19	-12.15	-22.28
18.07	NA	10.54	0.74	-9.12	-19.11
21.01	NA	12.34	3.61	-6.13	-16.12
24.00	NA	NA	6.66	-3.11	-13.18
25.99	NA	NA	8.65	-1.21	-11.26

If the input power is below the lower margin of the RSSM 8309 range the Low message is printed on the computer.

#### Software considerations and availability

The firmware running on the AT89C2051 microcontroller is responsible for reading the conversion results of the analogue to digital converter of the board through an SPI interface, scaling the results according to the 20mV/dB law and converting them from a binary form to a human readable decimal notation, which can be presented on the LC display. The control of the LCD and the transfer of the measurement results to a personal computer are also important tasks for the microcontroller. This explanation of the tasks the firmware is responsible for may sound very clear and simple but the efforts hidden behind building a reliable and accurate software for a measurement device like the RSSM 8309 are enormous. The assembler listing of the firmware source will take several valuable pages of the magazine, so it is not given here. It can be ordered (together with the object code) from the EW office (see above). The source code is well documented with comments, so I assume it will be easy readable by interested readers, which can also modify it to achieve certain design goals.

#### The RSSM 8309 prototype

Photos of the author's prototype of the RSS power meter are presented in Figure 10. Although housed in a plastic case, the RF-input of the device is carefully shielded to obtain the maximum possible sensitivity of the RSSM 8309. The display is mounted in a piggy-back style over the PC board (double-sided PCB) which is evident from the two photographs showing the device internals - one of the photos is with the LCD, the other is with the LCD detached. In the last photo the heart of the whole system is visible - the AD8309 integrated circuit, which is normally hidden below the LC display. The printed circuit board can be ordered from the editorial offices for readers interested in building the proposed device.

In conclusion the RSSM 8309 project presents not only a useful instrument for the workbench of every electronics professional but also allows deep insight into the theory and practical implementations of an interesting class of up-to-date integrated circuits - the demodulating logarithmic amplifiers.



**QUASAR 0871 electronics** CREDIT CARD SALES **717 7168**  
Helping you make the right connections!

Quasar Electronics Limited  
 PO Box 6935, Bishops Stortford,  
 CM23 4WP  
 Tel: 0870 246 1826  
 Fax: 0870 460 1045  
 E-mail: sales@quasarelectronics.com

Add £2.95 P&P to all UK orders or 1st Class Recorded - £4.95,  
 Next Day (insured £250) - £7.95, Europe - £5.95, Rest of World - £9.95  
 (order online for reduced price UK Postage).  
 We accept all major credit/debit cards. Make cheques/PO's payable  
 to Quasar Electronics. Prices include 17.5% VAT.  
 Call now for our FREE CATALOGUE with details of over 300 kits,  
 projects, modules and publications.  
 MAIL ORDER ONLY.



#### Motor Drivers/Controllers

Here are just a few of our controller and driver modules for AC, DC, unipolar/bipolar stepper motors and servo motors. See website for full details.

**DC Motor Speed Controller (5A/100V)**  
 Control the speed of almost any common DC motor rated up to 100V/5A. Pulse width modulation output for maximum motor torque at all speeds. Supply: 5-15VDC. Box supplied. Dimensions (mm): 60Wx100Lx60H. Kit Order Code: 3067KT - £12.95  
 Assembled Order Code: AS3067 - £19.95

**NEW! PC / Standalone Unipolar Stepper Motor Driver**  
 Drives any 5, 6 or 8-lead unipolar stepper motor rated up to 6 Amps max. Provides speed and direction control. Operates in stand-alone or PC-controlled mode. Up to six 3179 driver boards can be connected to a single parallel port. Supply: 9V DC. PCB: 80x50mm. Kit Order Code: 3179KT - £9.95  
 Assembled Order Code: AS3179 - £16.95

**PC Controlled Dual Stepper Motor Driver**  
 Independently control two unipolar stepper motors (each rated up to 3 Amps max.) using PC parallel port and software interface provided. Four digital inputs available for monitoring external switches and other inputs. Software provides three run modes and will half-step, single-step or manual-step motors. Complete unit neatly housed in an extended D-shell case. All components, case, documentation and software are supplied (stepper motors are NOT provided). Dimensions (mm): 55Wx70Lx15H. Kit Order Code: 3113KT - £15.95  
 Assembled Order Code: AS3113 - £24.95

**NEW! Bi-Polar Stepper Motor Driver**  
 Drive any bi-polar stepper motor using externally supplied 5V levels for stepping and direction control. These usually come from software running on a computer. Supply: 8-30V DC. PCB: 75x85mm. Kit Order Code: 3158KT - £12.95  
 Assembled Order Code: AS3158 - £26.95

Most items are available in kit form (KT suffix) or assembled and ready for use (AS prefix).

#### Controllers & Loggers

Here are just a few of the controller and data acquisition and control units we have. See website for full details. Suitable PSU for all units: Order Code PSU445 £8.95

**Rolling Code 4-Channel UHF Remote**  
 State-of-the-Art. High security. 4 channels. Momentary or latching relay output. Range up to 40m. Up to 15 Tx's can be learnt by one Rx (kit includes one Tx but more available separately). 4 indicator LED's. Rx: PCB 77x85mm, 12VDC/6mA (standby). Two and Ten channel versions also available. Kit Order Code: 3180KT - £41.95  
 Assembled Order Code: AS3180 - £49.95

**Computer Temperature Data Logger**  
 4-channel temperature logger for serial port. °C or °F. Continuously logs up to 4 separate sensors located 200m+ from board. Wide range of free software applications for storing/using data. PCB just 38x38mm. Powered by PC. Includes one DS1820 sensor and four header cables. Kit Order Code: 3145KT - £19.95  
 Assembled Order Code: AS3145 - £26.95  
 Additional DS1820 Sensors - £3.95 each

**NEW! DTMF Telephone Relay Switcher**  
 Call your phone number using a DTMF phone from anywhere in the world and remotely turn on/off any of the 4 relays as desired. User settable Security Password, Anti-Tamper, Rings to Answer, Auto Hang-up and Lockout. Includes plastic case. 130x110x30mm. Power: 12VDC. Kit Order Code: 3140KT - £39.95  
 Assembled Order Code: AS3140 - £49.95

**Serial Isolated I/O Module**  
 PC controlled 8-Relay Board. 115/250V relay outputs and 4 isolated digital inputs. Useful in a variety of control and sensing applications. Uses PC serial port for programming (using our new Windows interface or batch files). Once programmed unit can operate without PC. Includes plastic case 130x100x30mm. Power Supply: 12VDC/500mA. Kit Order Code: 3108KT - £54.95  
 Assembled Order Code: AS3108 - £64.95

**Infrared RC Relay Board**  
 Individually control 12 on-board relays with included infrared remote control unit. Toggle or momentary. 15m+ range. 112x122mm. Supply: 12VDC/0.5A  
 Kit Order Code: 3142KT - £41.95  
 Assembled Order Code: AS3142 - £51.95

#### PIC & ATMEL Programmers

We have a wide range of low cost PIC and ATMEL Programmers. Complete range and documentation available from our web site.  
**Programmer Accessories:**  
 40-pin Wide ZIF socket (ZIF40W) £15.00  
 18V DC Power supply (PSU010) £19.95  
 Leads: Parallel (LEAD136) £4.95 / Serial (LEAD441) £4.95 / USB (LEADUAB)

**NEW! USB 'All-Flash' PIC Programmer**  
 USB PIC programmer for all 'Flash' devices. No external power supply making it truly portable. Supplied with box and Windows Software. ZIF Socket and USB Plug A-B lead not incl. Kit Order Code: 3128KT - £29.95  
 Assembled Order Code: AS3128 - £39.95

**Enhanced "PICALL" ISP PIC Programmer**  
 Will program virtually ALL 8 to 40 pin PICs plus a range of ATMEL AVR, SCENIX SX and EEPROM 24C devices. Also supports In System Programming (ISP) for PIC and ATMEL AVRs. Free software. Blank chip auto detect for super fast bulk programming. Requires a 40-pin wide ZIF socket (not included). Available in assembled format only. Assembled Order Code: AS3144 - £49.95

**ATMEL 89xxx Programmer**  
 Uses serial port and any standard terminal comms program. 4 LED's display the status. ZIF sockets not included. Supply: 16-18VDC. Kit Order Code: 3123KT - £29.95  
 Assembled Order Code: AS3123 - £34.95

**NEW! USB & Serial Port PIC Programmer**  
 USB/Serial connection. Header cable for ICSP. Free Windows software. See website for PICs supported. ZIF Socket/USB Plug A-B lead extra. Supply: 18VDC. Kit Order Code: 3149KT - £29.95  
 Assembled Order Code: AS3149 - £44.95



[www.quasarelectronics.com](http://www.quasarelectronics.com)

Secure Online Ordering Facilities • Full Product Listing, Descriptions & Photos • Kit Documentation & Software Downloads

Figure 7: RSSM 8309 detailed circuit diagram

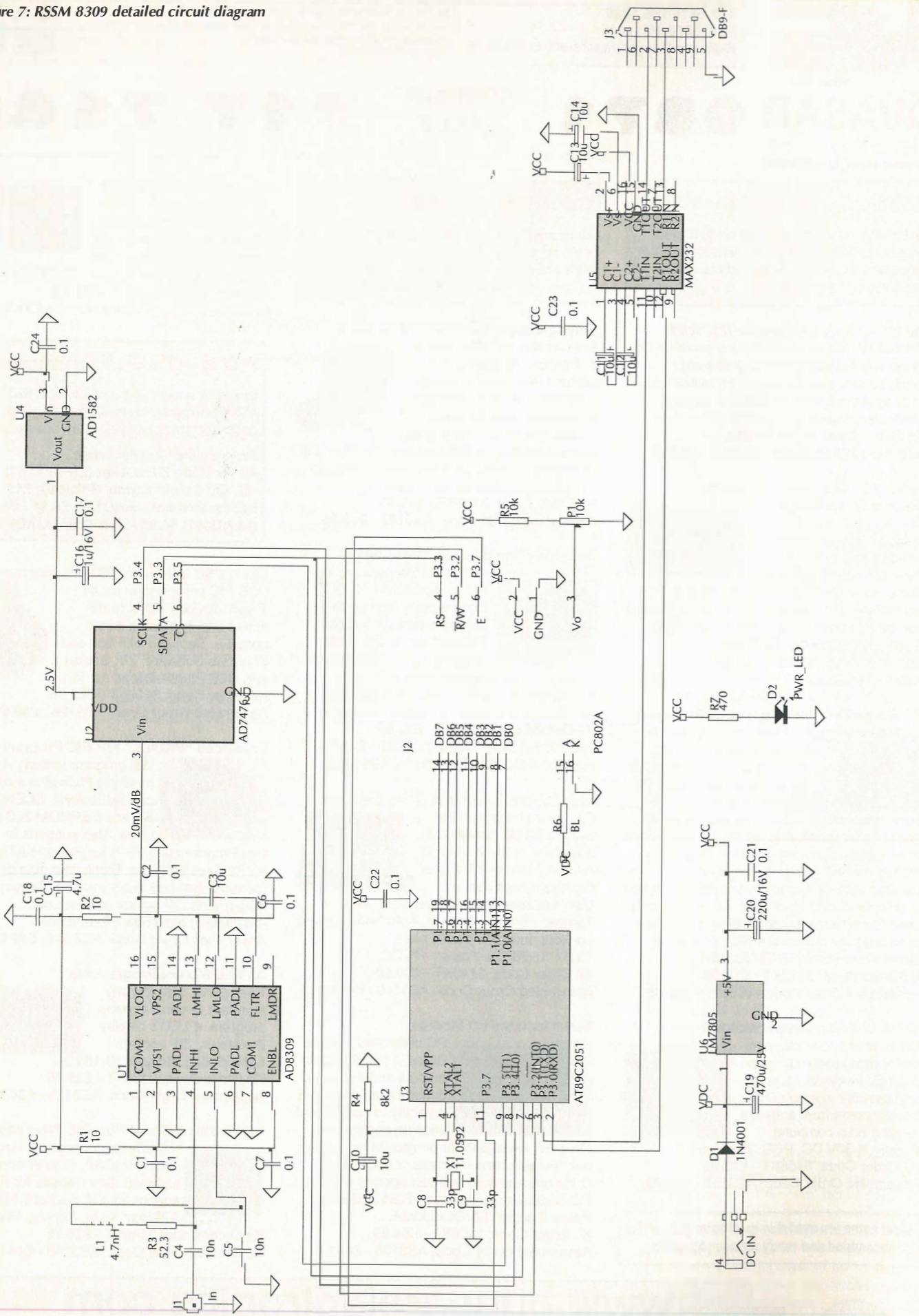
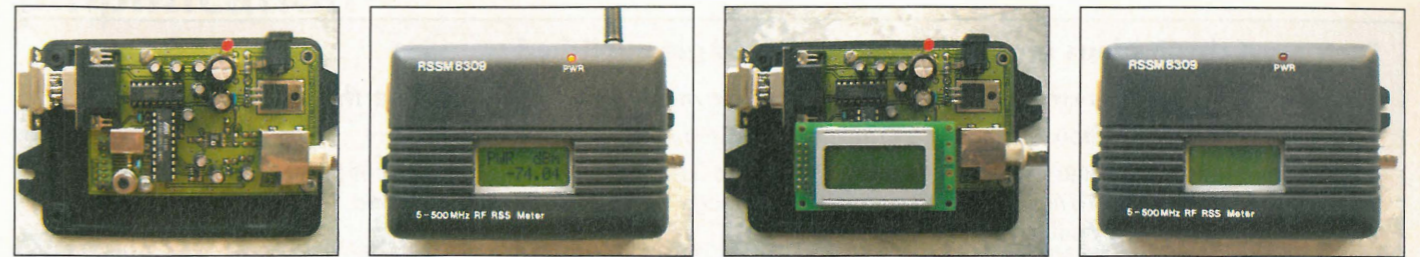

Figure 10: RSSM 8309 photos of the author's prototype



References and datasheets

- 1. AD8309 - 5 MHz – 500 MHz 100dB Demodulating Logarithmic Amplifier with Limiter Output, datasheet, Analog Devices, Inc. Rev. 0, 1998.
2. AD7476 / AD7477 / AD7478 – 1MSPS, 12-/10-/8-Bit ADCs in 6-Lead SOT-23, datasheet, Analog Devices, Inc. Rev. A, 2000.
3. AD1582/AD1583/AD1584/AD1585 - 2.5 V to 5.0 V Micropower, Precision Series Mode Voltage References, datasheet, Analog Devices, Inc. Rev. B, 2001.
4. AT89C2051 8-Bit Microcontroller with 2K Bytes Flash, datasheet, Atmel, www.atmel.com.
5. PC 0802-A Series LC displays, datasheet, PowerTip.
6. Cory, R., Phillip Halford, Make Precise Base-Station Power Measurements, Microwaves & RF, November 2002, pp.72-81.
7. Nash Eamon, Logarithmic Amplifiers-Explained, Analog Dialogue, Volume 33, Number 3, March, 1999.
8. Toh Yuping, Detecting Fast RF Bursts Using Log Amps, Analog Dialogue 36-05, 2002.

WE WILL BE MOVING SHORTLY - CHECK WEBSITE www.stewart-of-reading.co.uk FOR GENERAL STOCK MISCELLANEOUS CLEARANCE STOCK

Table listing various electronic components for sale, including oscilloscopes, multimeters, signal generators, and power supplies, with their respective prices.

STEWART OF READING 110 WYKEHAM ROAD, READING, BERKS RG6 1PL Telephone: (0118) 9268041 Fax: (0118) 9351696 www.stewart-of-reading.co.uk Callers welcome 9am-5.30pm Monday to Friday (other times by arrangement) USED EQUIPMENT - GUARANTEED. Manuals supplied. This is a VERY SMALL SAMPLE OF STOCK. SAE or telephone for lists. Please check availability before ordering. CARRIAGE all units £16. VAT to be added to total of goods and carriage.

**Fact: most circuit ideas sent to *Electronics World* get published**

**The best circuit ideas are ones that save time or money, or stimulate the thought process.**

*This includes the odd solution looking for a problem – provided it has a degree of ingenuity.*

Your submissions are judged mainly on their originality and usefulness. Interesting modifications to existing circuits are strong contenders too – provided that you clearly acknowledge the circuit you have modified. Never send us anything that you believe has been published before though.

Clear hand-written notes on paper are a minimum requirement: but you will stand a much better chance of early publication if you supply your idea electronically, preferably by email. Any diagrams need to be in a graphic format, not a CAD/CAM or any other obscure file.

Most circuit ideas contributors are paid £35 and good ones attract £50 or even £100! If winners would prefer archive CDs or subscriptions instead of payment please let us know when you send the idea in.

Where software or files are available from us, please email Caroline Fisher with the circuit idea name as the subject.

**Send your ideas to: Caroline Fisher, Highbury Business, Media House, Azalea Drive, Swanley, Kent, BR8 8HU or email to: ewcircuit@highburybiz.com**

## Telephone line monitor with extremely high impedance

The **Figure 1** circuitry monitors the usage of a telephone line. When no one is using the line, a red LED (D5) flashes every 0.8 seconds. If the line is occupied, the LED is off. One feature of the design is that the impedance of the circuitry to the phone line is over 5M ohms in all circumstances.

D1 to D4 eliminate the polarity of the phone line. R1 provides very high impedance to the phone line. C1 accumulates the current provided by the phone line through R1. IC1 is a nanopower comparator with a built-in 1.18V reference. R3 sets a positive feedback to the comparator. When the

circuitry connects to the phone line, the voltage on C1 (VC1) goes up. Before VC1 reaches 10.2V, the voltage on the positive input (VIN+) of the IC1 is below the reference voltage. The output of the comparator is low and the LED is off. When VC1 exceeds 10.2V, the comparator output becomes high and LED is on. Since R4 has a feedback to VIN+, VIN+ jumps from 1.18V to 2.35V which forces the output of the comparator to stay high. The LED presents a heavy load to C1 so VC1 drops quickly when the LED is on. When VC1 drops to 5.1V, VIN+ drops to below

the reference voltage and the LED turns off. Without the LED load, C1 starts to charge up again.

When the phone line is not used, VC1 swings between 5.1V and 10.2V. The LED off time is determined by R1, C1 and on time depends on C1 and R5. When the phone line is in use, the voltage on the phone line is too low to turn the comparator's output to high, so the LED stays off.

**Yongping Xia**  
Torrance  
California  
U.S.A

**Figure 1**

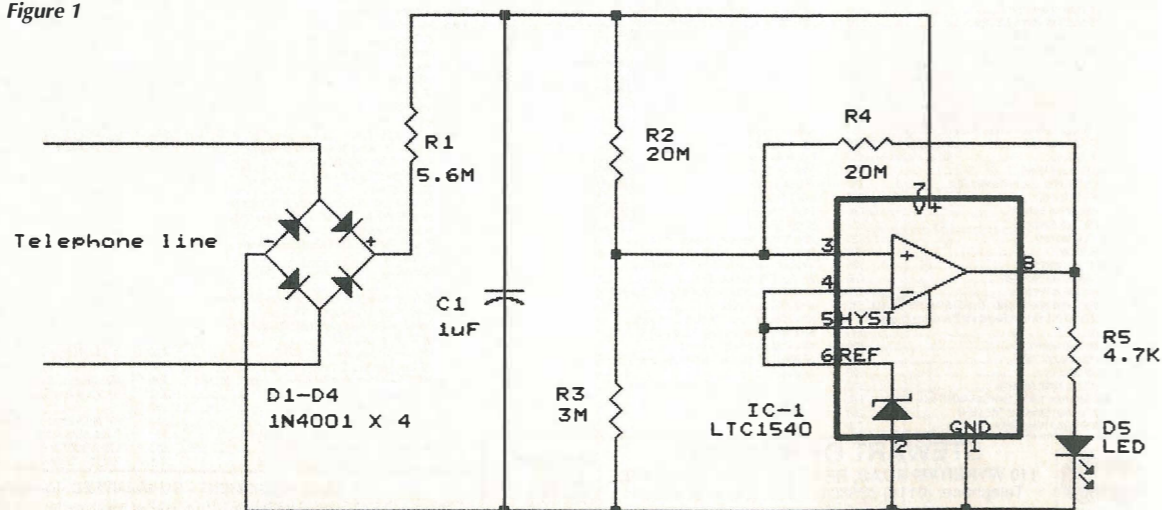

*This circuitry indicates the phone line usage through an LED*

## All-pass filter based on current-feedback amplification

A new and economical voltage-mode circuit implementing first order all-pass filtering signal is presented here. The circuit is based on a single current-feedback amplifier, or CFA, and three passive elements.

The circuit facilitates adjustment of phase angle via the frequency of the applied signal and/or a capacitor.

### Introduction

Current-feedback amplifiers have a high slew rate and offer constant bandwidth that's independent of closed-loop gain.<sup>1-3</sup> Consequently, CFAs are increasingly used as a basic building block to realise various analogue signal processing circuits.

The functions performed by this first-order all-pass filter are:

- 1) to shift the phase of a signal from 0 to  $\pi$  while keeping amplitude constant over the frequency range.
- 2) to enable implementation of various types of filter characteristics, and

3) to allow high-Q frequency-selective circuits.

A number of all-pass realisations have been reported in the literature using OTAs, FTFN, and CCII. However, it seems that a CFA based all-pass filter has not yet been reported<sup>4-8</sup>. Towards this end, we propose a simple first-order all-pass filter based on a single CFA, a single grounded capacitor, and two resistors.

Phase can be controlled by adjusting frequency of the input signal and/or grounded capacitor, which can be tuned by voltage, lending an electronic tuning feature to the circuit.

### Circuit analysis

Using the port relationships of the CFA,  $V_x=V_y$ ,  $I_x=V_z$ ,  $I_y=0$  and  $V_o=V_z$ , a straightforward analysis of the proposed circuit diagram shown yields the following voltage transfer function:

$$T(s) = \frac{V_o}{V_{in}} = \frac{1 - sCR}{1 + sCR}$$

The condition for realisation of the circuit is  $R_1/R_2=1$ , which is simple and temperature invariant. Also, being resistor ratio, the design is compatible with contemporary IC fabrication techniques.

Phase shift is expressed as:

$$\phi(\omega, C) = -2 \arctan(\omega RC)$$

Examination of this equation reveals that the phase can be controlled by adjusting the frequency of the input signal, and/or by changing C, without disturbing the condition for realisation of the filter.

### Experimental verification

We have used PSPICE simulation to verify the all-pass circuit shown with an AD844 amplifier,  $R_1=R_2=10.5k\Omega$  and a 10nF capacitor. The phase was designed to be shifted by 90° at frequency 41.5kHz. Gain and phase plots are shown. These are in close agreement with theoretical calculations.

The circuit is unaffected by temperature variations as it relies on the ratio of two resistors.

**N. A. Shah, M. F. Rather and S. Z. Iqbal**  
The University of Kashmir  
Srinagar  
India

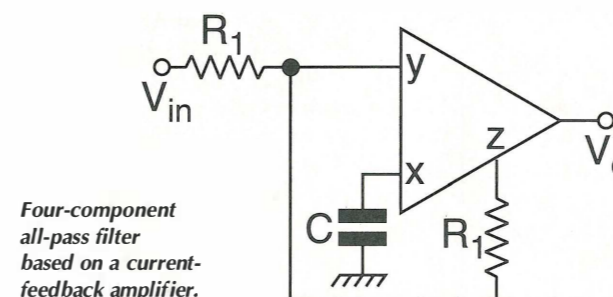

**Four-component all-pass filter based on a current-feedback amplifier.**

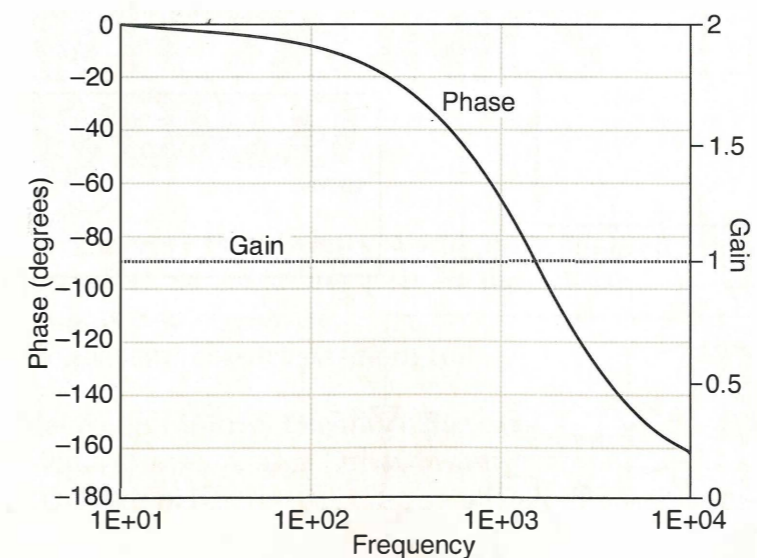

**Simulation of the all-pass filter's response based on a circuit using an AD844 as the current-feedback amplifier.**

### References

1. Abuelma'atti M.T and Al-shahrani, 'New universal filter using two CFAs', *Int. J. Electronics*, Vol. 80, pp. 753-756, 1996.
2. Hou, C. L., Huang, C.C. Lan, Y.S. Shaw and Chang, C. M., 'Current-Mode and Voltage-Mode Universal biquads using a single CFA', *Int. J. Electronics*, Vol. 86, pp. 929-932, 1999.
3. Liu, S.L., 'Universal filter using two CFAs', *Electronics Letters*, Vol. 31, pp 629-630, 1995.
4. N. A. Shah and C. K. Bhat, 'Voltage controlled all-pass circuit using OA', *Int. J. Electronics*, Vol. 66, pp. 263-266, 1989.
5. A. Fabre and J. P. Longuemard, 'High-performance Current processing all-pass filters using OA', *Int. J. Electronics*, Vol. 66, pp. 619-632, 1989.
6. Higashimura, M. and Fukui, Y., 'Realization of all-pass and notch filters using single current conveyor', *Int. J. Electronics*, Vol. 65, pp. 823-828, 1988.
7. I. A. Khan and Maheshwari, 'Simple first-order all-pass section using a single CCII', *Int. J. Electronics*, Vol. 87, pp. 303-306, 2000.
8. I. A. Khan and Maheshwari, 'Novel first-order all-pass section using a single CCII', *Int. J. Electronics*, Vol. 88, pp. 773-778, 2001.

# Traffic light controller

The traffic light controller of **Figure 1** comprises an astable of 555 timer of period 30 seconds (adjustable). Its output drives a decade counter whose outputs drive a decoder and its outputs go to inverters and their outputs to transistor relay drivers driving relays. R and R', are astable and counter resets respectively. **Figure 2** shows the traffic light arrangements. Referring to **Figure 3** relay R<sub>1</sub> with its NC contact glow red light r<sub>1</sub> of corner 1 and pedestrian red light rp<sub>1</sub>, NO contact of relay R<sub>1</sub> glow gp<sub>1</sub>, gp<sub>1</sub> green pedestrian lights. NOR gate with astable clock and decoder 'a' point drive relay R<sub>5</sub> through a transistor driver whose NO contact glow amber light a<sub>1</sub> which is between red and green light glows for the duration of astable Toff = 3 secs. Also AND gate with clock Ac and point a. with relay driver drive relay R<sub>6</sub> with NO contact glowing corner green in **Figures 4,5,6** which are similar to Figure 3. e,3,4 are corners. At the count of 4 the counter gets reset through decoder and inverter. Again the sequence starts. The prototype circuit uses 6V regulated supply and L.E.D.'s. The main circuit is with relay contact, 230V mains and bulb as in **Figure 7**.

The advantage of the circuit is that it uses few I.C.s and discrete components and it does not utilise microprocessor hence it is cheap and simple.

V. Gopalakrishnan  
Bangalore  
India

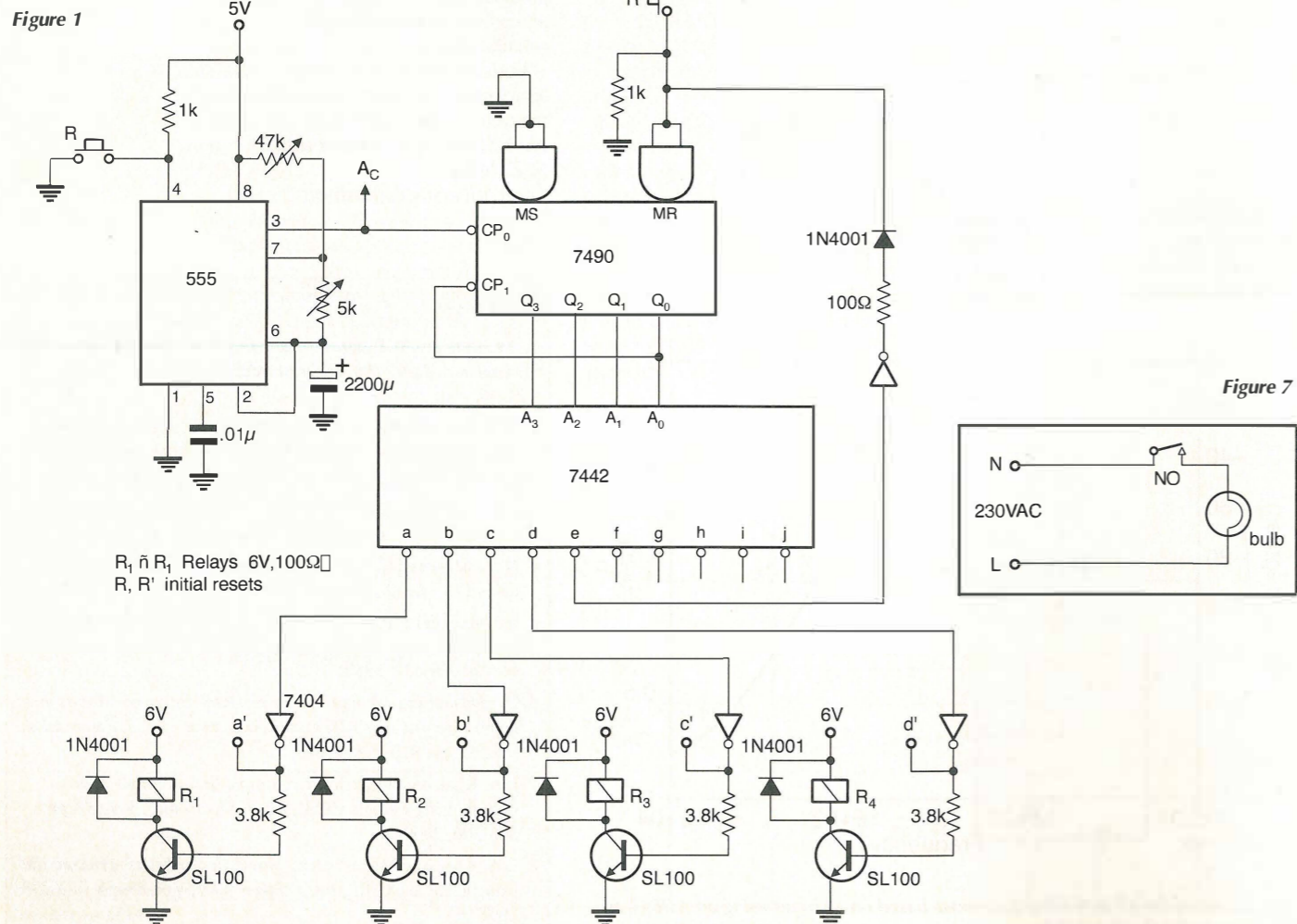

Figure 1

Figure 7

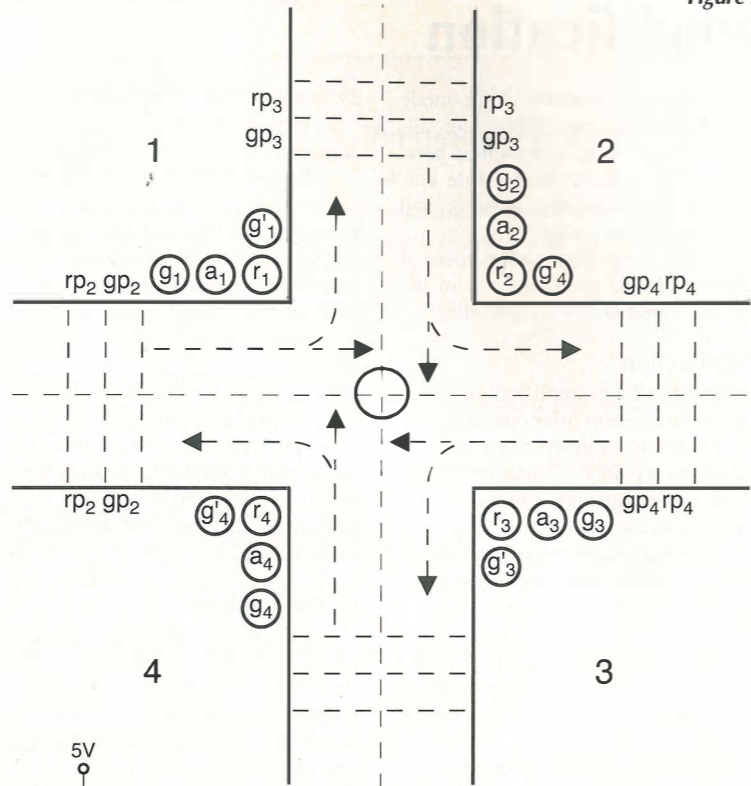

Figure 2

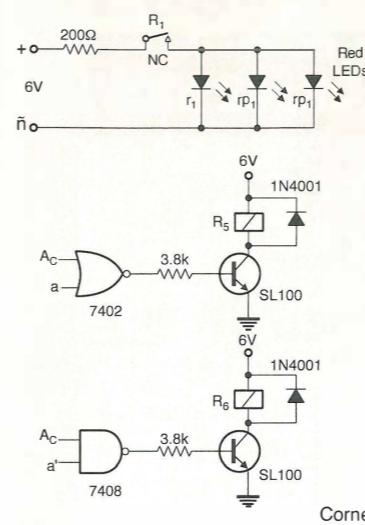

Figure 3

Corner 1

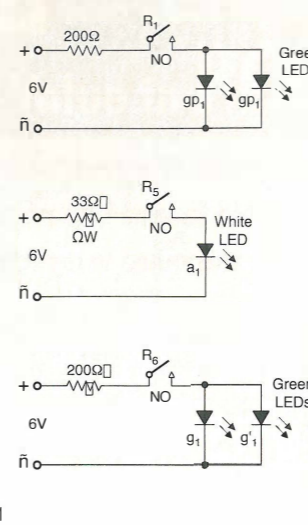

Figure 4

Corner 2

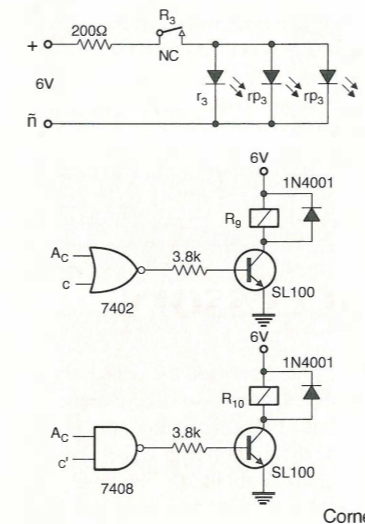

Figure 5

Corner 3

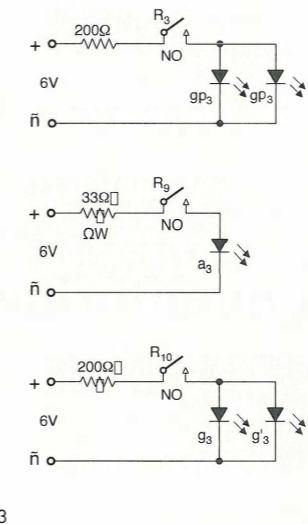

Figure 6

Corner 4

## ELECTRONICS WORLD

## Back Issues

Back issues of Electronics World are available priced at £4 including p+p in the UK and £4 plus p+p elsewhere.

Please send correct payment to:

Electronics World, Highbury Business, Media House, Azalea Drive, Swanley, Kent BR8 8HU

There are also a limited number of back issues from 2002 & 2003.

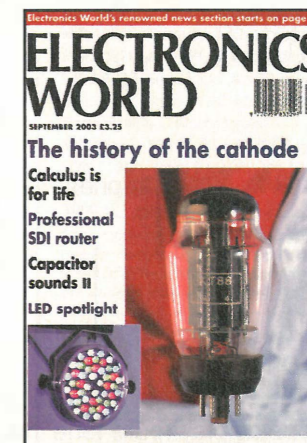

## Fly-by-wire integrity checker

Integrity of a remote potentiometer, such as in a 'fly-by-wire' control, is checked by this circuit.

For instance, if the ground end of the potentiometer goes open-circuit, the engine could over-rev dangerously. This fault condition is sensed by the window comparator built around  $IC_{1a}$  and  $IC_{1b}$ .

If the voltage at the top end of the pot rises by more than 0.5V, a fault condition is flagged. Similarly, if the voltage falls by more than 0.5V – which could happen with a short to ground – a fault is also flagged.

Output from the wiper is clamped low by  $D_3$  in the excess voltage condition; clamping is not necessary in the under-voltage condition, since the signal is already being dragged down low.

Under normal operation, point A is at +2.5V and output at C can swing from 0V to +3V. Capacitors  $C_{3,5}$  are added in order to suppress noise pick-up, with  $C_6$  as a final filter.

Parallel resistor  $R_2$  is there to ensure that the voltage levels presented to the op-amps do not exceed their common-mode range. In addition, the high-value

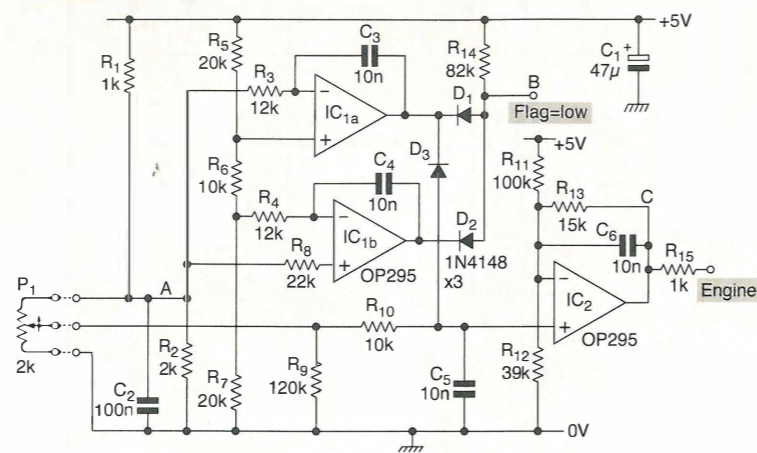

Monitoring the voltage over a remote potentiometer, this circuit provides an error signal in the event of a potentially dangerous failure.

pull-down resistor  $R_9$  offers protection to the engine in case the wiper – or the wire running to it – goes open-circuit.

Bias-resistor  $R_{11}$  offers a half-volt uplift to the inverting input of the op-amp  $IC_2$ ; this allows the clamp  $D_3$  to operate satisfactorily, as well as ensuring that there is a small dead

zone at the bottom end of  $P_1$ .

The idle speed can then be set independently at the engine, rather than relying on the 'zero' of the throttle pedal or stick.

**C. J.D. Catto**  
Cambridge  
UK

## Oscilloscope stereo monitoring accessory

This circuit was developed for a presentation I gave on oscilloscope applications. The idea came from the illustration of the Tektronix 760 Stereo Audio Monitor in a book about

stereo sound. Although the circuit is straightforward enough, the application might be of interest to readers with a scope having X and Y inputs.

$IC_1$  and  $2$  provide the necessary low impedance drive (to prevent crosstalk) to the summing amp  $IC_{1-3}$  and the difference amp  $IC_{1-4}$ . Each has a gain of about 20. The level control is a linear two-gang pot. I thought that the tracking should be better than with a log pot. It is, in fact, very good, but the 4k7 provides a trim at the lower end of the range if needed. All resistors are 1% and thus no balance adjustment is needed in the difference amp. The resistors  $R_5$  and  $R_{10}$  protect the outputs from accidental grounding.

Balance is tested either by applying the same signal to both inputs or with the 'Check balance' switch (optional).

The circuit was intended for occasional use so it is supplied from a 9V PP3 battery. A ICL7660SCPA switched capacitor voltage converter chip generates the negative rail for the op-amps. This chip is cheaper than a second battery, but as it works at 10kHz care is needed with decoupling.

In use the accessory displays stereo balance errors clearly and the 'width' of the stereo image is also very apparent.

**Tony Meacock**  
Norwich  
UK

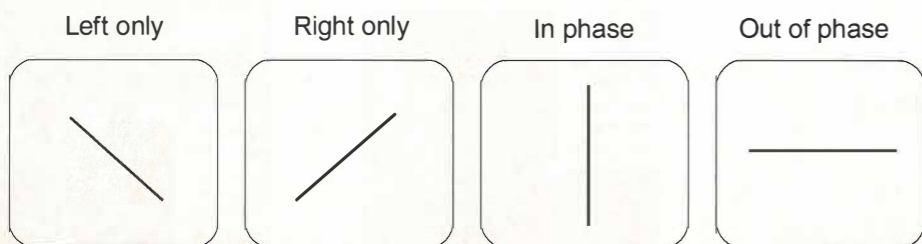
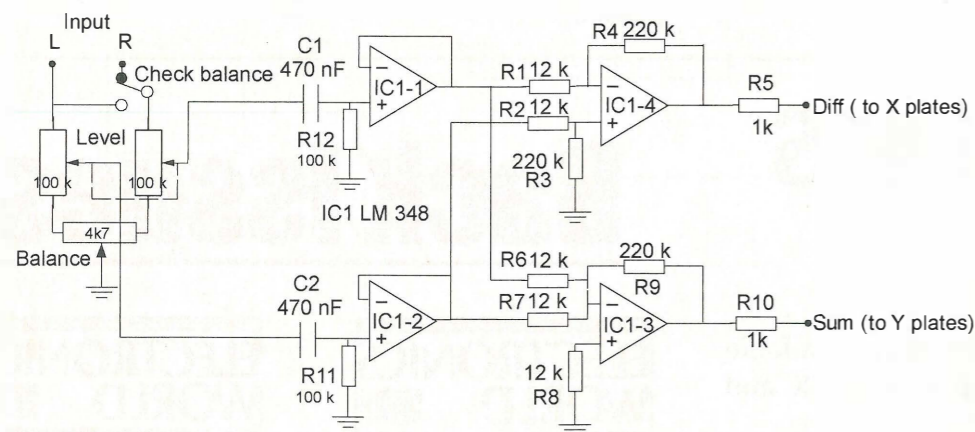

Oscilloscope display (pure tone input).

**Easy-PC** for Windows

## World Beating Value in PCB Design Software

from **£97**

High performance Windows based PCB Design Capture, Simulation and Layout software at prices you'd expect from your local computer store!

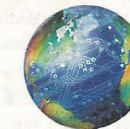

**NEW!** in Easy-PC 7

- Library Databook
- Step and repeat plotting
- Swap Connection Mode
- Dimensioning
- Copy to Metafile plus much more.....

Stop press... by customer demand, now with Tsien Boardmaker 2 design import...

Number One Systems delivers true 32 bit Windows software applications including features that a few short years ago would only have been available in software tools priced in the thousands!

Test drive Easy-PC and Easy-Spice for yourself and be prepared to be amazed at the super value...

Call for a brochure, price list and demo CD on +44 (0)1684 773662 or email [sales@numberone.com](mailto:sales@numberone.com)

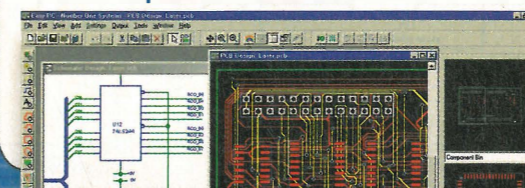

Number One Systems

Number One Systems  
Oak Lane, Bredon  
Tewkesbury, Glos GL20 7LR  
United Kingdom

or download from  
[www.numberone.com](http://www.numberone.com)

## PCB-POOL

SERVICING YOUR COMPLETE PROTOTYPE NEEDS

- Prototypes at a fraction of the cost
- Industry standard quality
- Tooling and setup included
- Follow up series runs
- Any contour
- CAM / CAD consulting
- Fr4 1.6mm, 35µm Cu

PRICE EXAMPLE:  
1 EUROCARD DS18B20  
+ Tooling  
+ Photoplots  
+ VAT  
= £ 29.89\*

**€49**



FREE with first order (while stocks last)  
may differ slightly to model shown

Freephone  
**0800-389 8560**

Simply send your files and order ONLINE:

**WWW.PCB-POOL.COM**



## WATCH SLIDES ON TV MAKE VIDEOS OF YOUR SLIDES DIGITISE YOUR SLIDES (using a video capture card)

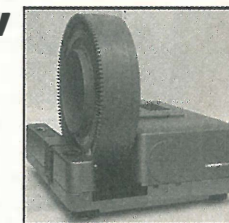

"Liesgang diatv" automatic slide viewer with built in high quality colour TV camera. It has a composite video output to a phono plug (SCART & BNC adaptors are available). They are in very good condition with few signs of use. For further details see [www.diatv.co.uk](http://www.diatv.co.uk)

Board cameras all with 512x582 pixels 8.5mm 1/3 inch sensor and composite video out. All need to be housed in your own enclosure and have fragile exposed surface mount parts. They all require a powersupply of between 10 and 12v DC 150mA.

47MIR size 60x36x27mm with 6 infra red LEDs (gives the same illumination as a small torch but is not visible to the human eye).....£37.00 + vat = £43.48

30MP size 32x32x14mm spy camera with a fixed focus pin hole lens for hiding behind a very small hole.....£35.00 + vat = £41.13

40MC size 39x38x27mm camera for 'C' mount lens these give a much sharper image than with the smaller lenses.....£32.00 + vat = £37.60

Economy C mount lenses all fixed focus & fixed iris

VSL1220F 12mm F1.6 12x15 degrees viewing angle.....£15.97 + vat = £18.76

VSL4022F 4mm F1.22 63x47 degrees viewing angle.....£17.65 + vat = £20.74

VSL6022F 6mm F1.22 42x32 degrees viewing angle.....£19.05 + vat = £22.38

VSL8020F 8mm F1.22 32x24 degrees viewing angle.....£19.90 + vat = £23.38

Better quality C Mount lenses

VSL1614F 16mm F1.6 30x24 degrees viewing angle.....£26.43 + vat = £31.06

VWL813M 8mm F1.3 with iris 56x42 degrees viewing angle.....£77.45 + vat = £91.00

1206 surface mount resistors E12 values 10 ohm to 1M ohm 100 of 1 value £1.00 + vat 1000 of 1 value £5.00 + vat

866 battery pack originally intended to be used with an orbital mobile telephone it contains 10 1.6Ah sub C batteries (42x22dia the size usually used in cordless screwdrivers etc.) the pack is new and unused and can be broken open quite easily.....£7.46+vat = £8.77

Please add 1.66 + vat = £1.95 postage & packing per order

**JPG ELECTRONICS**

Shaws Row, Old Road, Chesterfield, S40 2RB

Tel 01246 211202 Fax 01246 550959 Mastercard/Visa/Switch

Callers welcome 9:30 a.m. to 5:30 p.m. Monday to Saturday

# Easy & inexpensive temperature controller

I have recently designed and built an inexpensive Temperature Controller which is very easy to build with readily available components. I am a final year Electronics engineering student and last semester's I was asked to build a temperature controller for a server room which needed to be maintained within the temperature range of 16°C & 25°C by using two air conditioners. The existing temperature controller was based on a microcontroller (80c196) and was very expensive to replace in case of any fault. Therefore I was asked to build a cheaper and easier model.

The main objective of the system is to maintain the temperature of the room in between 16°C & 25°C. If the temperature is less than 16°C both the ACs are switched off. In between the normal range of 16°C to 25°C the ACs are alternately switched on and off every 4 hours so as to not put too much load on any one machine for a long period of time. If the temperature of the room rises above 25°C then both the AC M/Cs should be switched on. And if this condition stays for more than 5 minutes this is reason for concern and thus an alarm is triggered off.

Figure 1 shows the block diagram of the circuit.

The transducer employed to sense the temperature was a wall-mountable temperature sensor. It provided a linear current O/P of the range 4-20mA, corresponding to the temperature 0-to-50°C. After passing this O/P current through a I-to-V converter the corresponding voltages were obtained. These were then compared with two reference voltages on two comparators to check for the range of 16°C to 25°C as shown in Figure 2.

These two O/Ps from the

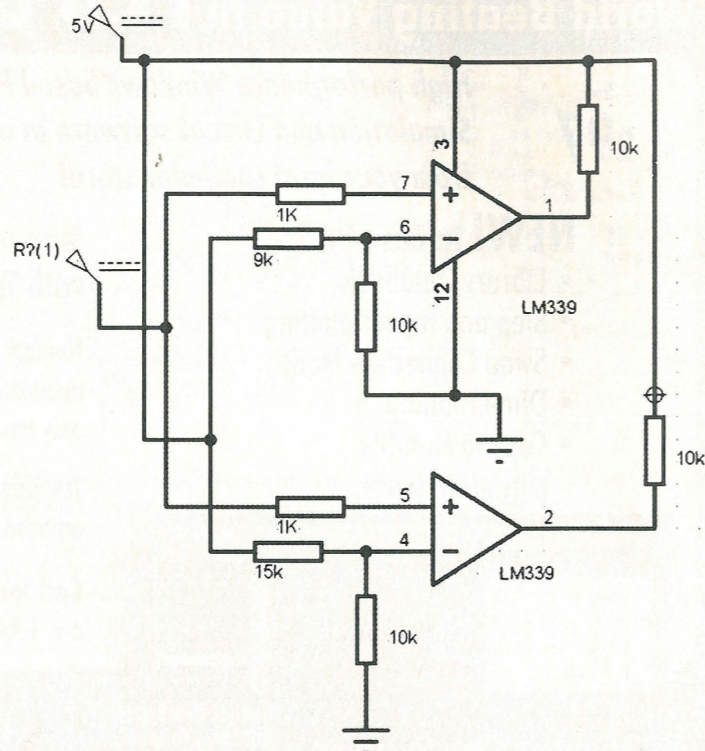

Case	Comparator 1	Comparator 2
T < 16°C	LOW (0 V)	LOW (0 V)
16°C < T < 25°C	LOW (0 V)	HIGH (5 V)
T > 25°C	HIGH (5 V)	HIGH (5 V)

Input pin	MUX 1	MUX 2
0	LOW (0 V)	LOW (0 V)
1	Q (From JK F/F)	Q' (From JK F/F)
2	Q (From JK F/F)	Q' (From JK F/F)
3	HIGH (5 V)	HIGH (5 V)

comparators are fed into the selection lines of a dual 4-to-1 multiplexer as in Figure 3.

So when the temperature is less than 16°C, both the comparator

Outputs are LOW and the first I/P lines from each MUX gets selected thereby making both Outputs LOW. As the temperature increases and reaches the range in between 16°C

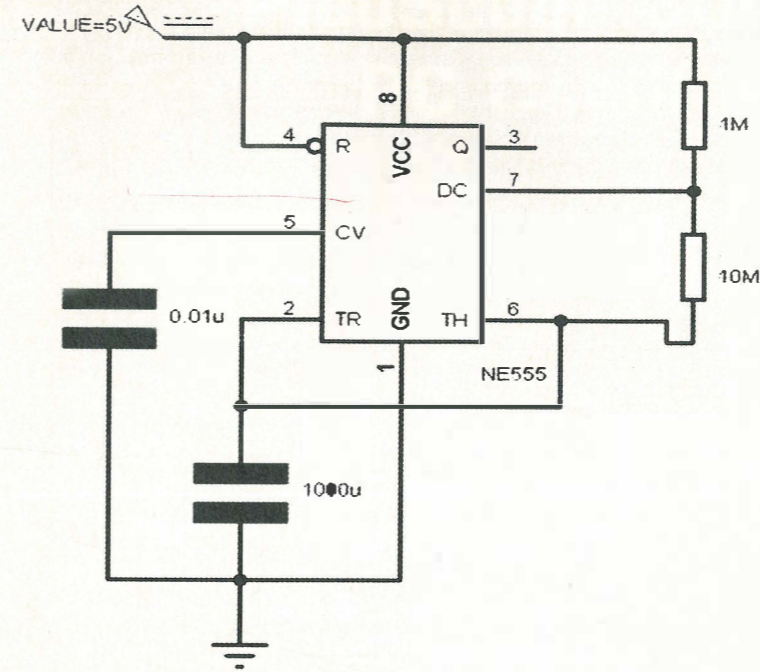
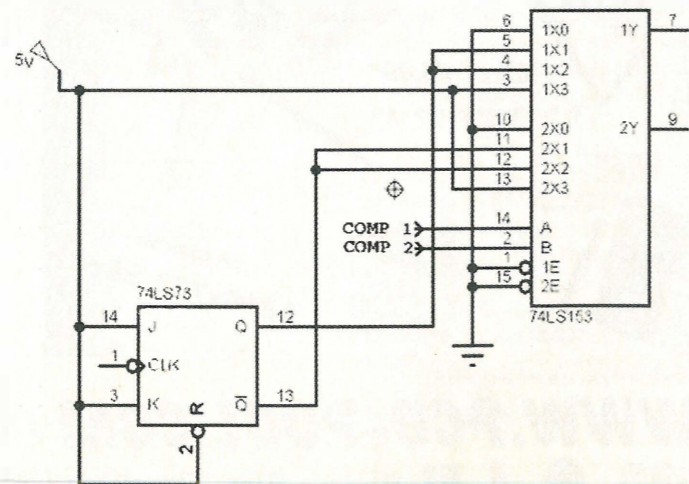
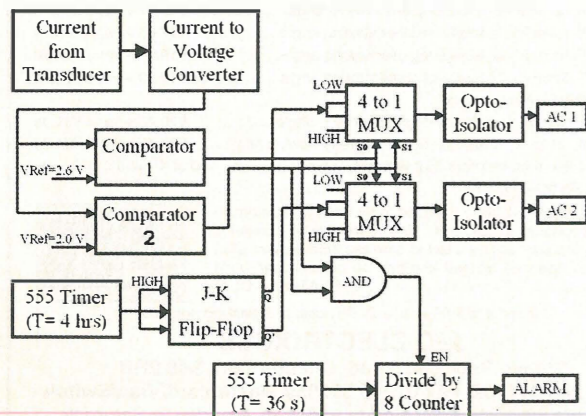

Timing duration	Q OUTPUT	Q' OUTPUT
00 am - 04 am	HIGH	LOW
04 am - 08 am	LOW	HIGH
08 am - 12 pm	HIGH	LOW
12 pm - 04 pm	LOW	HIGH
04 pm - 08 pm	HIGH	LOW
08 pm - 00 pm(am)	LOW	HIGH

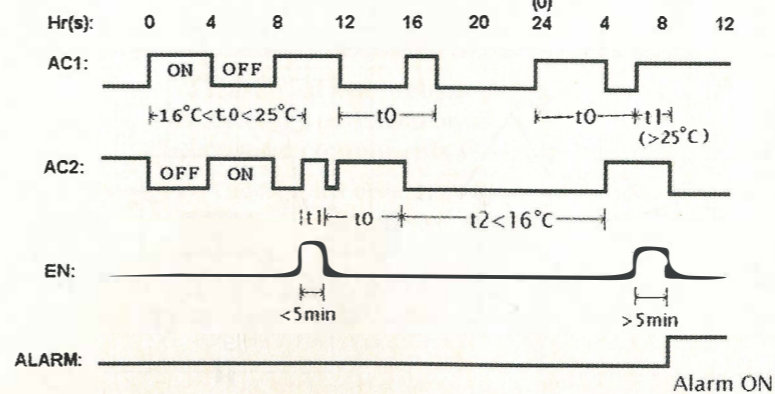
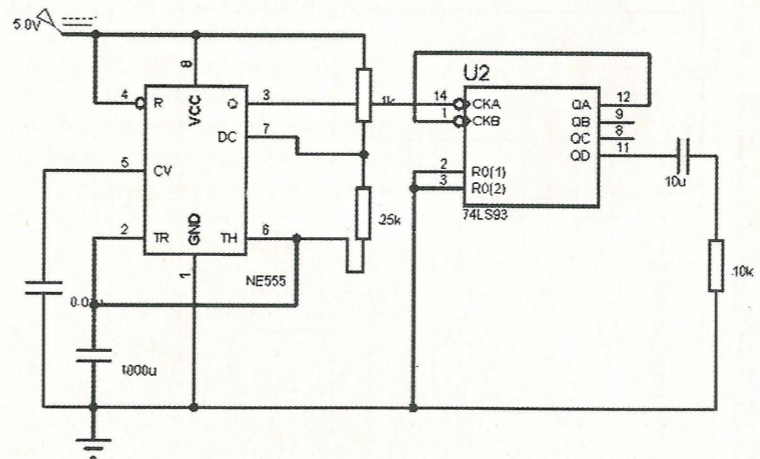

and 25°C, the Output from the first comparator is LOW and from the second is HIGH. This selects the second and third input lines from each MUX and the Output is the same as that of the JK F/F Output.

Now the JK Flip Flop Output is such that it toggles every 4 hours thereby switching one AC ON and the other AC OFF alternately. The J-K F/F has both its J and K I/Ps tied to the 5V supply so as to make it toggle at every Clock Pulse. It is fed by a 555 timer in astable mode, to make its OUTPUT toggle every four hours. This is shown in Figure 4.

If the temperature increases to over 25°C then both the comparator O/Ps become HIGH and the fourth I/P line of each MUX gets selected. This gives rise to a HIGH voltage at both outputs thereby switching ON both the ACs. These two O/Ps from the MUXs are also fed to the NAND gate and the output becomes LOW. This O/P is fed to the (active low) Reset pins of the counter. This starts the counter which is fed by a 555 timer generating a calculated clock pulse. The output from the counter after passing through a differentiator circuit and a half-wave rectifier generates a pulse to trigger a SCR, which then latches itself to start the alarm Figure 5.

Now even if the counter signal goes low, the SCR will remain latched thereby making the alarm ring continuously. This alarm can only be switched off by manually disconnecting it from the power supply. On the other hand, if the temperature becomes below 25°C before 5 minutes, the OUTPUT of the NAND gate goes HIGH thereby resetting the counter.

Finally the OUTPUT logic signals from the MUX optically coupled to the power line signals in order to ensure proper isolation. This then goes to the latch and switches ON or OFF the A/C M/Cs depending on their present state.

A look at the timing diagram Figure 6 will give a better picture into the working of the circuit.

Here initially the temperature is normal (i.e. 16°C < T < 25°C) and so the two ACs alternately get switched ON and OFF every 4 hours. Then the temperature rises to above 25°C at around 1000 hours and both ACs get switched on. This makes the Enable (EN) for the alarm circuit go on as well. But since the time for which temperature remains above 25°C is less than 5 minutes. Hence the alarm does not go off. Now the temperature returns to normal and the ACs get back to their



usual mode of operation (alternating every 4 hours). Then at around 1800 hours the temperature goes below 16°C and so both ACs get switched off. This remains until the temperature rises to above 16°C again. Then at around 600

hours the next day the temperature rises to above 25°C and remains so for more than 5 minutes thereby triggering off the alarm. Now even though the temperature comes down the alarm is already latched and needs human

intervention to switch it off.  
The final and total circuit is shown in **Figure 7**.  
**Soumyadip Rakshit**  
Kolkata  
India.

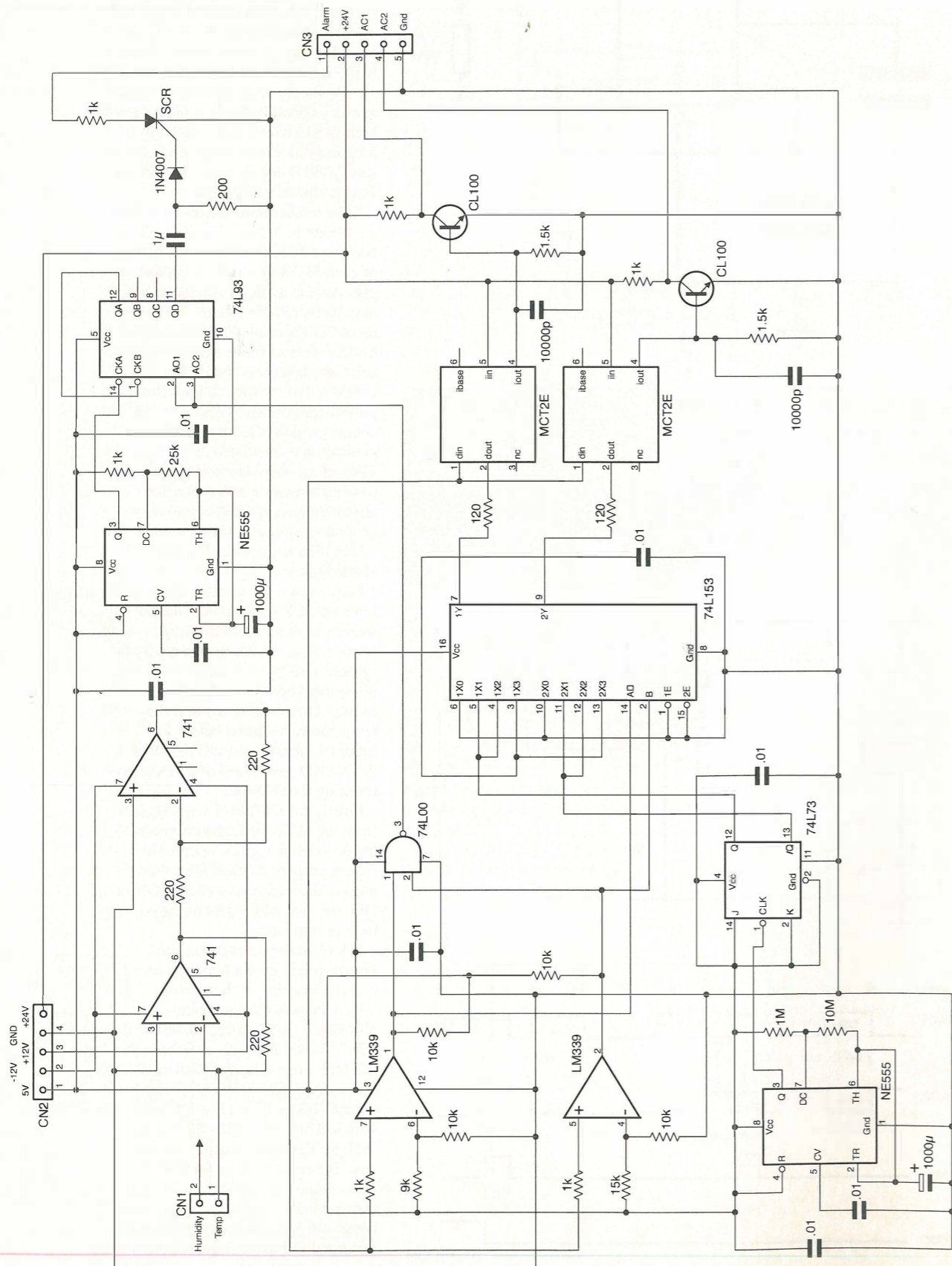

# PicoScope 3000 Series PC Oscilloscopes

The PicoScope 3000 series oscilloscopes are the latest offerings from the market leader in PC oscilloscopes combining high bandwidths with large record memories. Using the latest advances in low power electronics, the oscilloscopes draw their power from the USB port of any modern PC, eliminating the need for mains power.

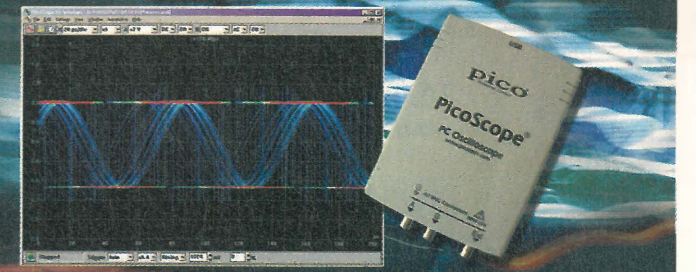

- High performance: 10GS/s sampling rate & 200MHz bandwidth
- 1MB buffer memory
- Advanced display & trigger modes
- Compact & portable
- Supplied with PicoScope (oscilloscope/spectrum analyser) & PicoLog (data acquisition) software.

PicoScope	3204	3205	3206
Bandwidth	50MHz	100MHz	200MHz
Sampling rate (repetitive)	2.5GS/s	5GS/s	10GS/s
Sampling rate (single shot)	50MS/s	100MS/s	200MS/s
Channels	2+Ext trigger	2+Ext trigger/Sig gen	2+Ext trigger/Sig gen
Oscilloscope timebases	5ns/div to 50ns/div	2ns/div to 50ns/div	1ns/div to 50ns/div
Timebase accuracy	50ppm	50ppm	50ppm
Spectrum ranges	0 to 25MHz	0 to 50MHz	0 to 100MHz
Record length	256k	512k	1MB
Resolution accuracy	8 bits / 2%		
Ranges	10mV to 2V/div		
PC Connection/Power supply	USB 2.0 (USB 1.1 compatible)		

Tel: 01480 396395  
www.picotech.com/scope194

**pico**  
Technology Limited

## FRUSTRATED!

Looking for ICs TRANSISTORS?

A phone call to us could get a result. We offer an extensive range and with a World-wide database at our fingertips, we are able to source even more. We specialise in devices with the following prefix (to name but a few).

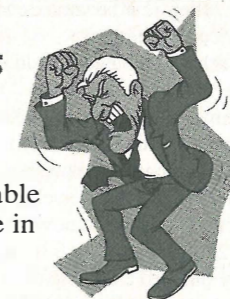

2N 2SA 2SB 2SC 2SD 2P 2SJ 2SK 3N 3SK 4N 6N 17 40 AD  
ADC AN AM AY BA BC BD BDT BDV BDW BDX BF  
BFR BFS BFT BFV BFX BFY BLY BLX BS BR BRX BRY BS  
BSS BSV BSW BSX BT BTA BTB BRW BU BUK BUT BUV  
BUW BUX BUY BUZ CA CD DX CXA DAC DG DM DS  
DTA DTC GL GM HA HCF HD HEF ICL ICM IRF J KA  
KIA L LA LB LC LD LF LM M M5M MA MAB MAX MB  
MC MDA J MJE MJF MM MN MPS MPSP MPST MPST  
MRF NJM NE OM OP PA PAL PIC PN RC S SAA SAB  
SAD SAJ SAS SDA SG SI SL SN SO STASTK STR STRD  
STRM STRS SVI T TA TAA TAG TBA TC TCA TDA TDB  
TEA TIC TIP TIPL TEA TL TLC TMP TMS TPU U UA  
UAA UC UDN ULN UM UPA UPC UPD VN X XR Z ZN  
ZTX + many others

Please visit our website at  
www.cricklewoodelectronics.com  
17 thousand components in stock

Mail, phone, Fax, Credit Card orders & callers welcome.



**Cricklewood Electronics Ltd**

40-42 Cricklewood Broadway, London NW2 3ET  
Tel: 020 8452 0161 Fax: 020 8208 1441

Visit our new [www.cricklewoodelectronics.com](http://www.cricklewoodelectronics.com)  
Email: [sales@cricklewoodelectronics.com](mailto:sales@cricklewoodelectronics.com)

## Back Issues

Back issues of Electronics World are available priced at £4 including p+p in the UK and £4 plus p+p elsewhere.

Please send correct payment to:  
Electronics World, Highbury Business,  
Media House, Azalea Drive, Swanley,  
Kent BR8 8HU



There are also a limited number of back issues from 2002 & 2003.

# to the editor

Letters to "Electronics World" Highbury Business, Media House, Azalea Drive, Swanley, Kent, BR8 8HU  
e-mail EWletters@highburybiz.com using subject heading 'Letters'.

## Circuit idea does work

I would like to reply to Mr. J. Marsh (*Letters* page July 2004) saying that my 555 Long Delay Timer Circuit Idea does work:

It has been attached to my own personal radio, which I use a lot, for about a year. I am satisfied that my explanation of the circuit is correct.

The more conventional 555 astable and counter sleep timer circuit I mentioned in the text, was built as a present (and combined with a spare radio).

I had built, tested and used the circuit before submitting it.

Alan Bradley  
Belfast  
NI

## Powers that be

As an adjunct to the subject of challenging accepted theories (editorial comment to letter, June issue), I have always admired those willing to stick their necks above the parapet and challenge accepted doctrine. As someone who has often struggled with their higher education, with overheating of the CPU (Cerebral Processing Unit) — symptomatic of a processor fault technically known as "being thick" — I have come to realise that it is not entirely my problem.

I wish that General Semantics had been taught at school (Collins' English dictionary: general semantics n. (functioning as singular) a school of thought, founded by Alfred Korzybski, that stresses the arbitrary nature of language and other symbols and the problems that result from misunderstanding their nature.)

When looking around to see who else is having difficulty understanding, or challenging what has been stated, and finds everyone else with their head down, it is easy to reinforce the idea that everyone else understands and, ergo, you must be "thick". It is not just complicated words, symbols and theories that have to be fully explained. It took me years to understand what "To be, or not to be" actually meant, as it was far too simple to warrant any words of explanation from the English Lit. teacher. (Out of interest, I have asked around about this and still find people who haven't a clue what it means.) I learnt of one young kid who hated maths and couldn't get the hang of multiplication. When the exact meaning of that strange symbol "??"

was demonstrated to him, his face lit up and he began to excel at maths.

Let me give another example of something that I couldn't understand, but was far too timid to be the only one to challenge. We all learnt that two-squared equals 4 and two-cubed equals 8, didn't we? (before it became trendy to be numerically illiterate).

At junior school, the teacher told us that the power of a number is the number of times that that number had to be multiplied by itself. She then looked kind of embarrassed (as though she didn't understand this herself) before adding that "2 to the power of 1 is two, and 2 to the power of 0 is one". I was deeply puzzled and looked around, but everyone else seemed to understand, so I bit my lip. Now, 45 years later, I am vociferously challenging that statement. Two, multiplied by itself no times (not at all), is blatantly not one, whilst two, multiplied by itself once is just about the first thing you learn in maths.

Just to convince myself that I hadn't mis-heard, years later I referred to its dictionary. Again, quoting Collins':

Exponent n. ... (4) Also called: power, index. Maths. a number or variable placed as a superscript to the right of another number or quantity, indicating the number of times the number or quantity is to be multiplied by itself.

(If you number the number of times that "number" is mentioned, your brain is probably much "numb-er" by now!)

The contamination of brain-washing and disinformation has spread. Here is an extract from *Electronics Monthly*, Oct. 1985 (I still have the yellowing original sheet, such is my disquiet about

false data being pumped into us!)...

"Thus  $10^9$  stands for 1,000,000,000, which is 10 multiplied by itself 9 times. Note also that  $10^1 = 10$  and  $10^0 = 1$ ."

That last little throwaway line is said with the same sincerity and explanation that leads me to believe the author had the same brainwashed teacher. It is implying that if you multiply 10 by itself just once, the answer is 10. This can be scientifically disproved by taking the log. of 10, multiplying by 10, then taking the anti-log of the result. This is no trivial matter: even in the vastness of space, an overshoot of 100,000,000 kilometres could have implications for a planetary landing.

I would suggest a Revisionist's dictionary entry something along the lines of:

Exponent n. (4) Also called: power, or index. Maths. an integer (written as a superscript to the right of another number or expression that represents a number), indicating how many times that unity is to be compound-multiplied by the first number. Thus  $10^3$  stands for  $10 \times 10 \times 10$ . Note that  $10^1 = 10$  and that an exponent of zero indicates that no multiplication takes place, i.e.  $10^0 = 1$ .

However, even this is not enough to prevent confusion to someone who accepts the above, but then sees that a scientific calculator can handle an exponent such as 1.5. Great confusion sets in again as you figure out how to multiply by 3 one-and-a-half times. The answer isn't what you might eventually hazard a guess at.

If you think that you are too dumb (i.e. brain-numb) to understand electronics, is it perhaps that various terms have never been satisfactorily explained? Take, for example, the Exclusive-OR — either A OR B, but excluding the case of A AND B. No great problem with semantics there. But can someone please tell me what an Exclusive-NOR is? To my mind, NOR is already an exclusive term — neither A NOR B excludes three out of four terms. What is there further to exclude? And did I say there was no great problem with the Exclusive-OR

definition? By extrapolation, a 3-input Exclusive-OR gate is, obviously, a gate that detects A OR B OR C, but excludes the case of A AND B AND C. Why not? All of a sudden, the actual logic requirement is tacitly taken as an odd parity detector but excluded from its name (e.g. 74S135). Who has decided what is to be excluded?

Trevor Skeggs  
Beccles  
Suffolk  
UK

## Alkaline battery failures 2004

I wonder if any other reader has experienced the sort of problems I have had with alkaline batteries, mainly this year. I would recommend checking they're rarely used or backup battery equipment soonest!

In the last few months I have found several cases of cells either leaking, splitting their case, or bulging at the ends. In several instances this has required dismantling and cleaning of the unit. These have not been either excessively old or over discharged at heavy load.

For example TV and VCR remote controls lying unused for six months, quartz clock, cells just loose 'on the shelf', cells in a flashgun which was working before and was definitely not left on.

I know they can burst if shorted, but in each burst case where they were in equipment the unit worked OK afterwards and there was no evidence of shorting.

Cells were mostly AA, AAA, C size, though 1 PP3 also failed. The manufacturers involved were all reputable brands, such as Duracell, Ever Ready, Panasonic, Ray-O-Vac etc. and all within the marked use by date.

Peter Hague AMIEE  
By email

## Cyril's conundrum

I trust that I am not too late to add something to the discussion started by Cyril Bateman. My own introduction to the conundrum happened while doing National Service some time in 1953. Our Officer i/c decreed that one Saturday morning per month would be given over to lectures on basics in electrical and electronic theory. Suffice it to say that he would neither be giving any talks, nor would he be attending!

At the conclusion of the first lecture (and I think the last) following a reference to Kirchoff's Laws, someone raised the example of the Cube. Our guru, an Air Radar Corporal fitter, groaned, drew the diagram on the

board and promptly declared that it was not amenable to analysis, i.e. he couldn't solve it. Why no one suggested actually making it when it was physically practicable, I don't know. Possibly we were too close to lunchtime. Obviously though the Cube was not a new problem even then; perhaps Wheatstone originated it.

With time comes wisdom and experience. Some years later I came across it again and, realising that it was amenable to analysis, succeeded in solving it for myself as many others have done.

My motive in writing now arises from something I found recently while browsing in an old text book, *Electricity* by C.A.Coulson DSc. FRS\*. First published in 1948, my edition is the fifth from 1958 but I assume from the preface to the second and later editions, that the relevant passage was in the original. Chapter V, Art. 43 consists of a number of examples. Example 1 is our old friend with the result stated (5R/6) but the proof left as an exercise for the student.

Here is the kicker. Coulson's example is in two parts - the first quoted above but the second is this: if an e.m.f. is applied to the ends of one edge, show that the perceived resistance is  $7R/12$ . Any takers?

\* *Electricity* C.A.Coulson, DSc., FRS. Published by Oliver and Boyd Ltd. in the series University Mathematical Texts.

Ian Cuthbert  
Gillingham  
Kent  
UK

## History re-written?

Mr Catt tells us that Alan Turing's "history has to be rewritten now for PC reasons". A brief appraisal of Turing's contribution to computing written before the term PC seems to have been invented can be found in Simon Lavington's book *Early British Computers* published in 1980.

Whilst at the National Physical Laboratory, Turing presented a complete and costed design for an electronic stored-program computer in February 1946. Construction of a pilot model of the ACE did not start until after August 1947 and the computer ran its first program in May 1950. An NPL proposal and a draft contract were sent to Manchester in December 1946 but were declined by F. C. Williams. That was two years before the order being placed with Ferranti to construct a machine to Williams' design in October 1948.

Turing left NPL in the summer of 1947 and, after a sabbatical year at

Cambridge, moved to the Mathematics Department at Manchester University in Autumn 1948. Lavington's assessment is that he did not materially contribute to the machines at either University. At Manchester he devoted most of his energy to developing early programming techniques. Perhaps that is why his name never appeared on any documents read by Mr Catt whilst he was working at Ferranti.

ACE had a 32 bit instruction which required the programmer to specify seven quantities. Lavington suggests that to modern eyes this seems like microprogramming and comments that the programmer "had to be aware of the detailed interconnections of the machine". As he also points out, "this highly original programming strategy for ACE was born in 1945, before most other early computers were even a twinkle in their designer's eye".

Dr. Les May  
Rochdale  
Lancashire  
UK

## Hot air

I've been a regular reader of *EW* for many years. Since moving to Cumbria three years ago, it's been hard to find *EW* on the shelves. I was disappointed after finding the July issue to discover that appeared to be devoted to the 'Old Farts Club', who were rambling on about memories and various philosophical points which I doubt were of interest to the majority of readers. In any case, the points could have been made more concisely, leaving room for articles of real substance. I refer specifically to *Class A Imagineering Part II, Boolean Castles In The Sky and Catt Flap I & II*.

I look back to articles of real value such as those by Doug Self which even if one did not agree with all that was proposed, the articles provoked logical thought and in my case, my own designs, construction and testing.

Historical reviews can be interesting. John Linsley Hood did it well, but then he based them on solid experience, not hot air.

Please return *EW* to articles and discussion of real substance.

BTW. I am a fully fledged member of the above mentioned club who started off using thermionic valves (I still have a Williamson in the loft!), was later fascinated by 'red spot' transistors and has since moved on to explore the digital world.

Ken Hough  
By email

## Re: Catt flaps and other electron mysteries

Readers interested in electrical conduction disputes might find Bruce Scechter's article<sup>1</sup> valuable, it suggests, "A growing number of physicists are realising that their understanding of conductivity is on shaky ground to say the least."

Recent data has led to suggestions that some Cooper pairs (of electrons) condense into localised regions of vortices that have three options, one of which is thixotropic flow! More work is required before we can be more certain about electrical conduction; which tends to support Ivor's contentions

One of the consequences of these recent interpretations is that they appear, to me, at least, to be moving closer to descriptions<sup>2</sup> of current flow in vacuo (cathode ray tube), a copper wire (50µA DC) and a graphite rod given by Geoffrey Hodson in 1959. I can't see any of the details that Hodson and others have described although I can see very fine, iridescent rays of sunlight reflected off the convex surface of a chromed top, which exhibit movement, unless I keep very still, when the rays appear to be rigid and straight – quite immobile! And significant!! When I look at the sky, however, I can see a host of vortices not like those in Vincent's paintings of the sky above saint Remy, but much smaller; about a thousand per Steradian. They don't rotate like wheels with angular frequency ( $\omega$ ) but oscillate like the balance wheel of a wristwatch does; which is consistent with Dirac-Scrodinger (1930) analyses for Zitterbewegung, which is helical about the direction of current flow. These oscillations rise-up, counter clockwise, out of the background and reverse, clockwise fading to invisibility at a rate of 1.87Hz, except for the bright light at the centre of the complex whose luminosity is invariant. This bright light enables me to follow the translational motion of the complexes, which appears to be curvilinear (in mean-free-paths about five times the diameter of the complex, fifty times the diameter of the bright light) before sensing another complex in a gentle deflection, not at-all like the staccato deflections in Brownian motion. This tends to support Nigel's contention about momentum exchange (Electron Mysteries, *EW*, letters, July 2004), and it is consistent with the bifurcate solution of the fundamental quadratic in GR theory: wave-like and point-like.

If David had have used a 3D phosphor, he might have seen Zitterbewegung super imposed on the

helices tracks, parallel to the principle axis and not unlike the compression-rarefaction in longitudinal waves. In his last letter to 'Nature', Paul Dirac advised physicists not to continue ignoring negative root of the total energy equation  $E^2 = C^2 P^2 + (mc^2)^2$ . This is what gives the helices a sort of 'back-stitch' motion at a rate of 1.87Hz parallel to the current (nominal) direction in Maxwell's left-hand rule (IML), which Nigel Cook emphasised in his *EW* articles *Electronic Universe 1/2*, Hodson also described the 'skin-effect' electricians one familiar with, analogous to the Meissner effect which occurs in conductors close to absolute-zero when experiencing magnetic fields.

Zimanyi's work has shown that extremely high magnetic flux densities reverse the Meissner effect by cutting a swathe through the conductor lattice; even insulators! A similar process occurs with high currents, which bore annular paths through conductors, permitting the 'vortex molasses'; to flow thixotropically, in limit-cycles, probably, of radius  $r$ ; which is the  $\lambda$  in Bragg's equation. Not the first time an equation has given the right answer for the wrong reasons. I'm grateful to Nigel for mentioning the Earth-Mars spacing because me-thought I could almost discern evidence of this in the slightly-varying shapes of the envelopes of tiller's periods; the radius  $R$  in  $c=2\pi RF$  is for Mars' distance from the sun, however; or rather, the radius of an orbit (Kirkwood gap) between the orbits of Earth and Mars, which move in Hilda Clumps – honestly (see *Does God play dice?* page 256, under Resonances)

Another effect which was described is 'pulsation' somewhat akin to a boa swallowing some unsuspecting geezer who was a bit too slow off the mark. This frequency of pulsation, which might be 1.87Hz, appears to resonate with the 'skin of the vacuum' formed when the energy decoheres into particles, using modern parlance.

Stephen Phillips, who has worked with Abdus Salem on Quark Theory and Superstrings, has gone to considerable lengths to analyse the observations of Hodson and earlier workers in the field, some of which were made in pre-Christian eras, and are depicted in Vedic texts, on stellae at Newgrange, the earliest settlements on Crete and elsewhere. And not only pictorially; Mayan inscriptions in stone from Chicken Itzà to the Guatemalan west coast indicate that earlier civilizations had knowledge of bifurcation constants, or the quotient  $F^1/F^2 = 1.87$ ; as did Job, or his

ancestors? And early Tibetan metaphysicians (vide *The secret doctrine*, Vol. 1, Sloka VI) David Reigle has translated verse 11<sup>3</sup> of Mûla Kâlachakra tantra (Kins-te) which describes a world-modelled which, although incomprehensible – incoherent nonsense in pigeon's terms – is not so very different from Ian McCrimmon's analysis<sup>4</sup>, suggesting four layers of gravity in terms of electronegativity and entropy (Mûla equals root, in Sanskrit) and more recently Watson and Keating at Reading university, with Paul Devereaux have measured resonances at '2Hz' (1.87?) and 4Hz (3.74), although, surprisingly, not Schumann Resonance (7.46Hz, mean), in many dolmens in the UK, suggesting that these were retreats not unlike les cloîtres de Saint Remy – mental hospitals, if you like?

Recent work by Jean Gabraith in the UK, and several in America suggest that Vincent didn't suffer from epilepsy or bipolar dissociation but was given bouts of spontaneous rising of Kundalini up the spine – an effect described as not unlike an electric shock, although in my case it had added feeling of reacting against the inertia of the universe as well as all the electricity being generated in the world at that instant. Quite ineffable – you have to experience it to know it, it's a bit like a near-death experience, which I had in 1987, just before closing time. Nope, wrong don't drink, don't do drugs, Jean now calls this SEUS – as in Oduseus! – Spontaneous emergence up the spine, which can leave victims traumatised, unlike artificial means, which have proved fatal. The most common sequelae to SEUS is isolation, or not wanting to socialise although trying; so it's understandable that people may be easily offended by letters in electronics journals; and your current policy on courtesy is in keeping with a trend which Graham Maynard, Robert Matthews, Marcello Truzzi<sup>5</sup> and others have appealed for, which, in simple terms, means, having a little respect for the other guy, or gal, whatever their viewpoint. Not beating the living daylights out of them just because they express some ideas that appear like 'incoherent nonsense.' As Dylan observed: 'time will tell, who's to blame, and whose been left behind, when you go your way and I go mine.' (*Leopard-skin, pillbox hats*). Some of the Ss in Jeans's audits became neutral readers, although not all: one became a leading authority on early dinosaurs virtually overnight! Whilst others became fluent in a hitherto unknown, or lost language, and a third – nothing, not a dickie bird, guess who?

## References

1. Bruce Scechter, *Ghost in the machine*, *New Scientist*, 38-41, 29.5.04.
  2. S.M. Phillips, *ESP of quarks*, pp 90 – 4, *Theosoph. Pub*, Wheaton, Illinois
  3. *S.D Symposium, San Diego, 1984*, *Wizard Bookshelf*, pp 54 – 67
  4. I. McCrimmon *The nature of the fifth dimension*, *Cosmaton pub.uk*
  5. M.Truzzi, *Reflections on the reception of unconventional claims in science*, *SMN network 84*, 14-16 spring 2004.
- Tony Callergari**  
Much Hadham  
Herts  
UK

## Discrimination?

I have just looked through the latest *EW* to hand (June) to fully check on an old suspicion of mine, and it seems I was right!

The articles, letters, and circuit ideas have 40 attributions. Of those, 8 names have only initials for the first names. Of the remaining 32, the first names seem to me to be exclusively male.

I wonder why this is? Some possible explanations:

1. *EW* has no female readers.
  2. Electronics as a profession/interest has no female participants.
  3. All female contributors hide behind initials.
  4. The Editor is a misogynist!
- From yet another male

**Tony Batchelor**  
Denmark

*I am certainly not a misogynist – so the other explanations must be right! - Ed*

*ED – I would like to refer readers to: www.setwomenresource.org.uk. See page 8 of this issue. J Massey, Production Editor.*

## Feynman's lectures amended

"The important conclusion is retained that motion (rotation in this case) of the source of mag-netic field **does not affect** any physical process, so long as such motion does not produce a time-varying field". W.K.H. Panofsky<sup>1</sup>.

In full agreement with the Panofsky statements, R. Feynman also disproves rotational relativity as applied to motional electromagnetic induction<sup>2</sup>.

*"It is known that Maxwell's electro-dynamics...when applied to*

*moving bodies, leads to asymmetries which do not appear to be inherent in the phenomena". A. Einstein<sup>3</sup>.*

Exhaustive experimental investigation, per-formed on systems in which  $\partial B/\partial t = 0$ , have shown the strict compliance of the Principle of Relativity for rotational arrangements<sup>4</sup>.

Newton's Third Law plays a crucial role in the analysis of the aforementioned experiments, and Einstein's early highlight rescues its full significance. A preferred frame for rotations (essential when dealing with inertial reactions<sup>5</sup>) has nothing to do in electro-dynamics.

After 170 years of controversy, we can ensure<sup>4</sup>, ([www.redshift.vif.com](http://www.redshift.vif.com)) that a wire clockwise rotating upon a stationary magnet is equivalent to a magnet counterclockwise rotating beneath the wire at rest in the lab (**Figure 1**).

In Rohrlich's recent words: "*Your experiments should remove the last shadow of doubt even of the most skeptical minds, that the electromagnetic phenomena are of a relativistic nature*"<sup>6</sup>.

## References:

- W. K. H. Panofsky and M. Phillips, *Classical Electricity and Magnetism*, *Add. Wesley* (1955).
- R. Feynman, *The Feynman Lectures of Physics*, *Add. Wesley* (1964).
- A. Einstein, *Annalen der Physik*, 17 (1905).
- J. Guala-Valverde, *Apeiron 11*, 327 (2004)
- A. K. T. Assis, *Relational Mechanics*, *Apeiron, Montreal*, (1999).
- F. Rohrlich, *priv. com. (Letter to J. Guala-V. Oct. 2002)*.

**Jorge Guala-Valverde**  
By email

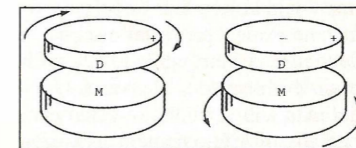

**Figure 1. Motion of the magnet M relative to the disk D governs electrodynamic induction.**

## Magnetoflux aether tunnel 1

I was disappointed by Clive Stephens' article. I thought there was going to be some new thinking which shed light on the 'mystery' of time. Instead the article seemed like the rambling of someone who has only a tenuous grasp of physics at best. The term 'magnetoflux magnetic aether

fields' occurs in the first paragraph without any explanation of what it means. Is it somehow different to a magnetic field? Why the term 'aether' when this is such an outdated concept?

Then we seem to move rapidly from electromagnetism to atomic physics and the statement 'a Helium atom on a star is envisaged as a neutron plus negatron pair surrounded by a positron enclosure...! Is it me? Has Clive Stephens lost the plot? Can anyone else understand what the article is about?

As for figure 3 (!) I could not fathom it at all. Is it me? Has Clive Stephens lost the plot? Can anyone else understand what the article is about?

**David J. Sweeney BSc. FIAP MIEE**  
By email

## Gobbledegook?

Regarding the article *An Electric Universe* by Clive Stevens in the August issue; do you think it might be possible to have it translated into English so that more people might enjoy it?

**Robert Baines**  
By email

## Magnetoflux aether tunnel 2

May I suggest some guidelines that may help you avoid printing such b\*\*\*\*cks as the above article?

- a) reject all articles referring to "God";
- b) reject all articles referring to "the aether" (unless in quotation marks);
- c) reject all articles by Clive Stephens;
- d) reject all articles by authors who sign themselves "M.I.E.E" (while such authors are allowed to remain members of the I.E.E)

The risk that you may bin some worthwhile articles is worth taking!

(There were other hints that you could have used: e.g. the use of formulae to obscure rather than clarify, for example the use of "wr" instead of the text "orbital velocity". Had this article been published for April 1st it might have been OK!).

2. Re. (letters) "The mystery of magnetic lines of force" (*EW* 8'04 p.56).

The magnetic lines of force are an illusion brought about by the fact that the iron filings being used to "probe" the magnetic field are themselves responsible for changing that field in a way which causes the filings to tend to align in separated filaments:

– Each filing in the filament becomes polarised with its own S pole towards the N pole of the magnet & its own N pole towards the

S pole of the next filing in the filament

- A filing falling near the end of an existing filament will tend to align with the magnetic field gradient, which will tend to be away from any existing filament (the iron provides an "easy path" for the magnetic flux, so the filament causes an artificially high field & field gradient at its end) and towards the other pole of the magnet along the curving path that we all recognise.

3. Re. "electric fence" - I found the fact that you published this amusing, (it could have worked, BUT...!!!) and it gave an interesting slant to my perception of its author's homeland!

**Paul Smith**  
Ipswich  
UK

### Alternative theories

I note with pleasure that *EW* has become a soap box for all kinds of wacky free thinkers. I have a few ideas of my own which I could expand into lengthy articles if you were interested. For example:

1. The universe was created by a massive explosion. Fortunately the earth was prevented from moving too far from the sun by a giant piece of knicker elastic. When the elastic was subjected to a peak strain equivalent to  $4.32921 \times 10^{-9} \text{mV}$  it snapped, leaving the earth stuck firmly in its present position.

B. I actually invented Boolean algebra before Ivor Catt did. Catt is an agent in a conspiracy to conceal my ideas.

5. It is perfectly obvious that Oxford logic is true. Therefore, Penge (London, SE26) logic is false because they cannot both be true at the same time.

**C. Nobs**  
Penge  
London SE26  
UK

### Colossus I

In *EW* August D.F.W. Jones asks if the Colossus rebuild team at Bletchley are aware of cathode poisoning when the valve heaters are run for long periods without the HT being on. Yes we are, in fact the matter is made worse because some of the heaters are run at under-volts, around 5.5V if they are far from a local 6.3V transformer. In my article (*EW* June 2004) I suggested that the heaters were on most of the time. I meant most of the time when somebody from the team is there, typically HT off/heaters on for three hours of a six-hour day. We have had very few failures over the ten years that the project has been running and about half of these have been

filament failures or heater/cathode shorts. The remainder could well be cathode poisoning; very low emission is the symptom. The heaters are brought up (and down) very slowly with two large variacs, courtesy of the Claude Lyons Company to minimise heater thermal failure.

Many thanks to Mr Jones for his letter.

(Any donation of GT1C thyratrons would be welcome.)

**Charles Coultas**  
By email

### Colossus II

Colossus was not a "computer" according to the definition. Computer = a computing device governed by a stored program (a very important restriction!).

Colossus (1943) was indeed the first electronic calculator, built for one specific application only, but not a computer. After Colossus, there came (Howard Aiken, Harvard 1944) Mark I, also an electronic calculator, but not totally electronic, as it used relays, too; then IBM ASCC (Automatic Sequence Controlled Calculator, 1944). The first computer (with stored program) was actually Z4 (Konrad Zuse, Germany, Neukirchen 1945), which appeared before ENIAC (Electronic Numerical Integrator And Calculator, 1946), which is usually accepted as the first real computer. Zuse made his first calculators as early as 1938/1939 (Z1) with relays!

**E-P Mänd**  
Helsinki  
Finland.

### More J LH

I read Ian Hickman's excellent tribute to John Linsley Hood in the May Edition, and like him I share the sadness at the passing of a great contributor to the magazine.

I met John only once at a Symposium at Reading University at which he made a presentation. I was able to have a short while to talk with him on that occasion. He was a very quiet man with a wealth of experience especially in Audio matters, as is still demonstrated in his many articles.

In the May Article Ian Hickman says that at least one of the contributors mentioned along with John is 'still with us' - I believe I may be the person referred to. Unlike John my past articles ranged over a wide range of subjects. Although now retired I still get involved in electronics generally, although I have not done much writing in the past 20 years, as for quite a while I ran my own small business in electronic design work, and much of what I was doing could not be written

up due to it being for a couple of local companies, and commercial security prevented publication.

I still read *Electronics World* every month, a habit which goes back to the early 1940s when as a young teenager I often had to wait for long hours for the bus home from High Wycombe after school, and I would go into the Library Reading Room where they had the *Wireless World* and *Electronic Engineering*, and also if memory serves me right the *Wireless Engineer* (now long gone). It was there that I began to learn my electronics.

**Laurence Nelson-Jones**  
Bornemouth  
Dorset  
UK

### Help

Could any reader please supply me with photocopies of the following articles by John Linsley-Hood.

Class A Power, *Electronics World*, September 1996 pages 681-687

A lifetime in Electronics, *Electronics World*, May 2000, page 417

Also any article/information regarding his class A 10 Watt amplifier and its upgrading to 15 Watts as I wish to build this amplifier for use in my home cinema for reproducing 16mm optical mono soundtracks.

I will meet all costs.

**L. Davies**  
By email

### Class A Imaginering 1

I am from the guitar amp world, where the issue over valve vs trannies is probably stronger than the hi-fi world. I've been designing guitar amps since I was about thirteen years old... and I'm fifty-seven now. So just a little while has passed since coupling EL84s & 34s with old Selmer transformers and copying my first Fender amps from, amongst others, Jack Darr's classic book *Electric Guitar Amplifier Handbook* (Howard Sams/Foulsham & Co - 1965), which I still have.

Well, to get to the point, I have made some not so surprising discoveries along that long journey. Firstly, and only in the last couple of years, I found an incredible difference in harmonic content when I built an unusual guitar distortion circuit constructed from the usual feedback diode clipping arrangement (log amp). To keep it as short as possible, I'll not go into the finer circuit details, but the difference I made to this circuit was thus... I gave it a bias control. As far as I know, this has never been done before, and I cannot think why I hadn't either!

This bias control meant I could

make each half cycle of the signal clip at a different level. The signal distortion could be swung from symmetrical to asymmetrical with great ease. Whilst testing the circuit one day, a couple of (well known) guitarists came to visit me and asked what I was up to. So I showed them. Well, both guitarists could hear a pronounced difference in the 'tone' as they described it, between the (unknown to them) two extremes of distortion made by a 1kHz tone through the circuit. It transpired that both much preferred the asymmetric distortion by a long way.

OK, so when I listen to the same test, as a technician, I could hear a definite rise in the second harmonic (SH) content as I swept the bias control from symmetrical into asymmetrical mode. After much listening and practical circuit making my conclusion is this: regardless of the technology being used, asymmetric distortion is the reason for increased SH content in an amplified signal which translates into that rich tone that so many seem to love.

And it can be done just as well with trannies as valves, because it is a naturally occurring phenomenon. What is happening in this test circuit equates very well to a Class-A single ended valve output stage, in as much that the single 'non-linear' conducting valve in this configuration cannot help but generate SH rich asymmetric distortion when driven too hard. Therefore, the measurable SH content is much higher than that measured in a Class AB1 or Class-B circuit.

OK, so you may well say even Class-B amps exhibit higher levels of SH content? Well, that can be true too, because the preceding stages in an all valve amp are mostly Class-A biased and will, when pushed and depending on how they're biased, generate higher levels of SH.

Now, I'm a practical guy who relies on his ears, so I've not found a need to do lots of maths or harmonic measurements. I know asymmetric distortion sounds better. That's all that matters to me. And, as a result, I have developed more sophisticated versions of this circuitry for use in commercial products.

On another point regarding valve output stages, I think many do not take into account that a speaker's impedance varies with frequency quite enough. At around 200Hz (typical guitar speaker) the impedance is around that quoted by the maker. Either side of this, it soon raises to more than double this figure. With a tranny amp, the power output will be greatest at frequencies around

200Hz. But there is still good output at other frequencies too.

With a valve amp, the output transformer must match the speaker. Because it is inductive, it cannot match the speaker at all frequencies, so it must be designed with a compromise. So which frequency should you choose for the transformer to be optimal at? Whatever frequency you choose it will not perfectly match the speaker at all frequencies, because the speaker is also a compromised component. So, here we have double trouble, which we in the music industry call a 'beneficial defect'. This happy accident means, to my ears, that the valve output stage has a good bass response and a reasonable top end... but it is muted by comparison to the tranny amp into the same speaker. This has to be an effect brought about by the frequency dependent (mis-)matching of the transformer/speaker relationship. The tone is always warm, but the bass is not that deep... rather like the frequency response of cassette tape compared to a CD.

Now of course, if you plot the frequency response of this valve amp on a dummy resistive load, then you'll see a completely different story. The plot will be a lot flatter and wider due to the fact that the resistor is a constant impedance at all frequencies. So, it's useless to measure a valve amp's frequency response on a resistive load! But then, what else can you use to get a truer picture? You tell me! A speaker is no good. Measuring the voltage across the varying impedance is a nonsense, because current through it is mainly out of phase with the voltage. I have found many valve amps to have increased output at around 120Hz. but you can't see this on a scope with a resistive load! Maybe you just have to rely on your ears.

However, once you know all this and think about the two technologies in a different light, then it is possible to design tranny amps that come very close to valve performance. But you have to throw the rulebooks out the window. Lateral thinking is the key. Don't just re-cycle the old ideas that never worked the first time around (like politicians frequently try to do). It is relatively easy to give tranny amps the 'lumps and bumps' in the tonal output of a good and pleasing valve amp by careful EQing at strategic points in the circuit to mimic the frequency response of a valve amp driven into a speaker load.

With regard to valve amps being

louder than similarly rated tranny amps, then we all must accept that a watt is a watt, whether a light bulb, a kettle or any other appliance. A watt is technology insensitive. Therefore, there must be other reasons, which possibly lie in the measurement methods. In fact reasons related to the possible 'tonal' response variances and causes discussed above.

Because valve amps have their power quoted as a result of measurements made across a resistive load, the results do not take into account the compromised matching/mis-matching of the transformer and speaker relationship. Therefore, although I have not conducted any tests (yet) on this topic, it is quite possible that the transformer could create 'perfect' matching within a narrow band of frequencies, which could be interpreted by the human hearing as a large increase in acoustic volume. This could be coincident with the hearing's natural preference and sensitivity to the bandwidth opted on by telephone engineers way back in distant time.

Another observation is that, many Fender valve guitar amplifiers ordinarily drive into a four ohm nominal speaker load and provide also, extension speaker sockets wired in parallel. However, there is only one transformer secondary winding! This seems to say that Fender don't mind you mis-matching the speaker load to the amp (which is variable anyway). And I have to say that, in my experience, this sometimes two or even one ohm loading does no apparent harm to the amplifier! Apart from, perhaps, running the output valves down quicker... which is so slow that no one worries or notices.

So the relation of this point to the amplifiers acoustic loudness discussion, is that in many valve amplifiers and speaker combinations, the load impedance and the secondary of the transformer could be 'allowing' gross mismatching at selected frequencies, thereby, producing many more watts into a reactive speaker/cabinet design than the rated RMS quoted for a resistive load. The power output for most 'old school' valve amps are spot on to that quoted across a resistive load, so I reckon the mismatch theory could hold true.

Proving or disproving this later 'idea' is bound to be difficult research, requiring much more brain power, time and equipment than I have available. So if anyone tackles it... I wish them luck! But there HAS

to be a solid reason for it which should be able to be confirmed.

Beyond this brief insight and personal views I have given, I cannot go into more detail because of protecting our design methods from competitive eyes. But I hope this 'outsider' view gives you cause for debate and alternative views on this fascinating and, no doubt, eternal subject.

I need to go and lay down now, but I shall look forward to the next part of this article.

**Stewart Ward**  
By email

## Class-A imagineering 2

As a life-long tech, "sound-guy" and musician, I'm astonished that Graham Maynard would draw conclusions from listening tests conducted in an empty disco. More than a metre from the stacks, all you are hearing are room resonances.

For much of the rest, the subjective jumping off point has been well covered by Douglas Self<sup>2</sup> in these pages, particularly on the matter of invariant power with complex loads. I would hope that we are a lot further ahead than Graham suggests.

It's true there are interactions between the amplifier and its load, and we can design amplifiers that will drive practically anything, but the problem seems more one of developing speaker systems that are better electrical loads for their range.

If simple reactive elements like caps are such a sin in the signal path, why be satisfied with such complex loads as transducers? If stability inductors are a sin, what of the passive crossover (yuk!) in the line?

Sound is best in the open air, and a hired 1200W/side active crossover 4-way handled the 12 channels of a raging bush band, penny whistle, violin, with magic clarity and transparency, but well under-run, for an audience of several hundred. No "tizzies", and no special gear, just well engineered.

Far from ignoring listening tests, I actively seek the observations of crew and audience members after each show and two regulars have become my canary in the mine for over-driving. It seems tinnitus sufferers have heightened sensitivity to distortion and clipping, experiencing it as a sharp pain, but are comfortable in a clean 100-110dB spl field (measured).

I look at real loads as a VI vector display on a scope using test and programme signals. It's very instructive and I commend it to interested readers.

In the context of "tizzy trebles" we should remember the 2N3055 has an fT of only 25kHz, has a pretty nasty

roll-off of hFE with rising Ic, and significant hole storage time.

Again, if I was desperate I might think of using a power transformer core for audio, like a factory PA, guitar maybe, but not Hi-Fi. Grain-oriented thin-lamination interleaved-winding output transformers were Hi-Fi before transistors. Even guitar amps used grain-oriented steel.

350 quid for an original, gassy, KT88? When I can have a brand new one, hard, with fresh cathode and better specs for a fraction of the price?

I'm afraid his remarks about current sharing in parallel devices also escape me. Looking at JLH's reprint, p47, fig.9(b) I see 0.25 ohm resistors in the emitters of the MJ480s, so local current-sharing feedback to prevent current hogging wasn't a mystery back then.

I hope the advent of cheap storage oscilloscopes and PC soundcard CROs will finally expose the truth or otherwise of the 'sine' vs. 'programme' argument.

If it can be demonstrated that the complexity of music can 'trick' amplifier components (ignoring speakers) in some unknown but significant way, some very basic ideas are called into question, viz:- in the original performance, was the complex sound of the orchestra correctly represented as a single pressure level at the microphone (and voltage through the chain)?

If the answer is "yes", then the 'programme' argument has an uphill battle. But if it's "no" some very basic physics is questioned, and therefore requires extraordinary proof. What seems to be implied is multiple pressures, diaphragm positions and signal voltages present at the same instant.

A central problem with recording for reproduction is dynamic range. The real world has too much and your gear not enough. So right at the front end the recordist has to "lose" some peaks somehow, kick and snare particularly, just to get it down with an acceptable S/N. And compressors do have signatures, some distracting, some that seriously alter the instrument balance (like MP3). DBX seems to work, Dolby is pretty nasty, but digital overs are terrible, so the oxide soft compression of tape is favoured.

The totality of an amplifier can be seen using a subtractive method, input to output. The ideal response is no difference at all [1], and we can build amps that are "blameless"<sup>2</sup>. Speakers on the other hand are a dogs' breakfast. Motorised cardboard in cubic pressure-vessels.

The character, positioning and

aiming of the stacks has more influence over the sound field than anything else.

Find the right set of room resonances and required EQ tends to flat, intelligibility is improved, the field is maximised, sweet in most of the room, and tractable in the mix. Then the crowd arrives and it gets better.

Modern big show line source arrays do the same trick using DSP's. If set up right they are so good it's scary. But they're not magic, they're well applied basic physics.

I look forward to Graham grounding his observations in the next part.

**Roly Roper**  
Ivanhoe  
Melbourne  
Australia

### References:

1. Elliot Sound – [www.sound.westhost.com/](http://www.sound.westhost.com/)
2. Doug Self – [www.dself.dsl.pipex.com/ampins/pseudosubjectv.htm](http://www.dself.dsl.pipex.com/ampins/pseudosubjectv.htm)

### Graham Maynard replies:

It is good to hear of Mr. Roper's experiences in the high power audio world, but he writes about subtractive observation via his (1) reference, which implies steady sinewave fundamental nulling. This is not the same as comparing a dynamically developed music waveform at the loudspeaker terminals with that having originally appeared at amplifier input; fundamental nulling compensates for a single frequency signal path propagation delay only. Indeed there is room here for someone with 24/192 processing capabilities to digitally delay an audio signal and subtract it from attenuated loudspeaker terminal output in order to monitor real time domain and amplitude distortion artifacts. Any takers?

Mr. Roper also states – "we can build amps that are "blameless" – citing his (2) reference, which is very similar to the range of articles already published in these pages some years ago. Does this mean that there is something wrong with us mere humans for deliberately and knowingly choosing to not use the design he references? My Parts 5 and 6 cover similar circuitry.

## Class A Imagineering 3

Having now been "treated" to sixteen pages with not one solitary supporting measurement, relying only on Spice based simulations as evidence for his 'first cycle' distortion, I am amazed that Maynard did not take rather more care with his simulation evidence.

In the Figure 3 schematic in the July

issue, he used a 5.3R resistor as his reference to represent the loudspeaker impedance at his 1kHz test frequency. Not so, as can be seen in my Figure 1 attached, at 1kHz using MC6 and Ohm's law, his loudspeaker schematic actually measures as 7.91Ω at 1kHz. The actual value of this reference resistor as used in his simulations, does substantially affect the end result.

My second point is his naive use of 'perfect' inductors and capacitors, resulting in a series combination of 4.7μF and 300μH to ground having an infinite 'Q'. That is not possible or realistic even at 1kHz and again does affect the simulation results.

In Figure 2 I have inserted realistic values of series R 'loss' resistances for these components, using component types as in high power loudspeakers. I assumed using Polypropylene capacitors only and air cored inductors, basing my values for the inductors on measurements of actual inductors from the high power range supplied by Falcon Acoustics. With these added loss resistances, my schematic now measures as 7.57Ω at 1kHz.

Maynard makes much about the affects a 6μH inductor can have on the amplifier loudspeaker combination. However at 1kHz a 6μH inductor has a small reactance, typically 38 milliohms which combined with its internal resistance, typically 20 milliohms plus, presents a near resistive 45 milliohms impedance. In comparison 5 metres of the common 79 strand speaker cable interposes 3.37μH, 84.2 milliohms resistance and 341.8pF to ground, between amplifier and speaker. EW Jan '97p53. From my own measurements and listening tests, I find it hard to accept that a low loss 6mH inductor can indeed be responsible for the errors Maynard reports.

My final point relates to his reliance only on Spice based simulations. My MC6 hardcopy manual discusses how Spice transient simulations can exhibit anomalous start up transients whenever the circuit being simulated incorporates capacitors or inductors. In particular the manual warns against performing such a single cycle distortion simulation.

While preparing my new article series, *Simulating Power Mosfets*, I found out the hard way that Spice can indeed exhibit such simulation start-up transients and as explained in this series, found it necessary to allow the circuit simulation to stabilise over ten complete cycles, to ensure consistent results.

Hence I am now left uncertain whether Maynard has in fact found a significant mechanism or whether we

are experiencing yet another Spice anomaly. That uncertainty can only be resolved by performing carefully considered practical measurements, not by listening tests. If Maynard has such hard evidence, I for one would like to be so enlightened, complete with full details of the measurement methods used.

**Cyril Bateman**  
Acle  
Norfolk  
UK

### Graham Maynard replies:

I respectfully thank Mr Bateman for his letter, and his useful additional figures which can help to complete the picture, though I'm not so sure that there should be any resistance added to the L in a paralleled L-C-R equivalence for driver resonance. I used the word 'approximate' when introducing the virtual Ariel loudspeaker in order to maintain an overview, and of course I realise that all components have other unavoidable plus representable series/parallel impedances, but these are not going to significantly alter the fundamental nature of my findings.

Mr Bateman's Figure 1 'impedance' characteristic is devoid of phase angle information, though his graphical representation does appear to confirm my average 5.3Ω value between 20Hz and 20kHz. I did not claim it was 5.3Ω for the 1kHz simulation, indeed I have been illustrating reactive current/voltage developments when compared to normal resistor testing methods. The impedance of a composite loudspeaker changes with frequency, but when we bench-test an amplifier we do not alter its load to match the 'resistance' of a particular loudspeaker at any instant or at any frequency. Besides, such varying of an amplifier's load resistance would still not be equivalent to real loudspeaker loading and this further clarifies testing problems, because it is the resultant dynamic loudspeaker current flow that induces a phase shifted output terminal or interconnector voltage error w.r.t. the amplifier's separately attempted and propagation delayed NFB output node voltage control. I'm also pleased that Mr Bateman is questioning computer simulation, because not all software has been programmed to set up initial conditions and thus calculate distortion similarly. Mr Bateman is correctly foreseeing problems before my mention of them in print, and so I hope there will be much less room for doubt by the end of my Part 6. If any software needs to run a

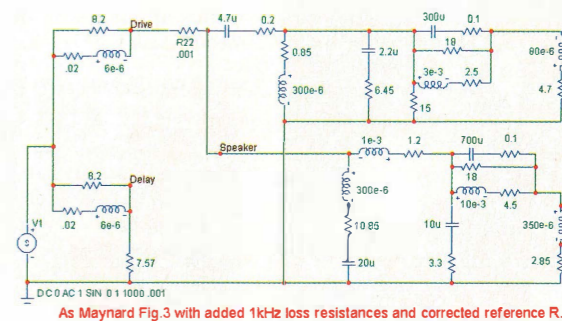
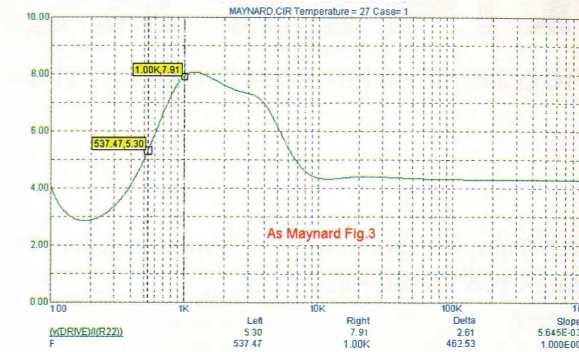

Top: Figure 1  
Below: Figure 2

simulation for say ten full cycles before giving 'desirable' results, then I do not see how it can be suitable for properly studying a first or any other early single cycle response, for second loudspeaker driving cycles can throw up problems too depending on bass/treble section time constants. Also what about any 'undesirable' simulation results; are they wrong, or due to flawed software, or inappropriate simulation, or merely unexplained? As I have clarified, it has always been prior listening observation and test bench experience that has suggested a need for to me run these simulations, not the other way round, even though much of my early observation was based upon high power audio, including open air.

If anyone doubts the possibility of such simulated findings they could try sketching out and calculating for themselves how a circuit (e.g. choke) might respond in the time honoured pen and paper 'C-I-V-I-L' way. They could also headphone monitor for possible audible differences whilst making series inductance/lead/load and loudspeaker-resistor loaded amplifier changes. Actually, it would be much better if others could emulate and hear, or fail to emulate and hear, my findings for their own interest and personal investigatory satisfaction, as Mr Bateman has already started, before accepting my text - or challenging it, though of course carefully considered questions and discussion can always further improve clarification.

# NEW PRODUCTS

Please quote *Electronics World* when seeking further information

## Pay & display parking monitored with GPRS system



Pay & Display parking terminals in the New Forest now use a GPRS wireless data network to monitor car parks centrally using Parkfolio software from Parkeon Ltd. The council has installed 57 Parkeon Stelio P&D terminals. The GPRS solution was chosen by the council because it wanted to be sure of an effective and continuous signal over a large area, parts of which are heavily wooded. The council also opted for Parkeon's financial and statistical software to analyse data generated by the P&D terminals. Information is downloaded via hand-held terminals through an infra-red connection, and can be downloaded to PCs for future reference.

Parkeon Ltd  
www.parkeon.com

## Pop-up powerdocks

A new range of pop-up powerdocks has been introduced by Häfele. Three can be stowed virtually flush with the desktop when not in use and pulled up vertically when needed, another is a lower cost



alternative which has permanent positioning at working surface level. Made of tough, high impact damage resistant plastic they are available in aluminium, silver and light grey colouring. Three models are power cabled for immediate use with a moulded male connector for use with mains leads and one has a standard format 3-pin wall plug.

Häfele UK Ltd  
www.hafele.co.uk

## Power interconnects for modern VRMs

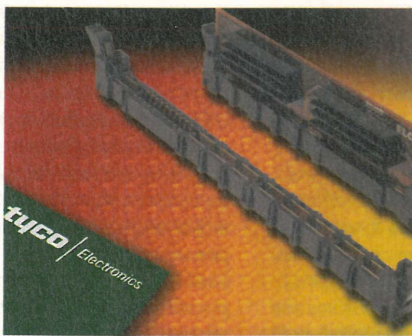

Until recently voltage regulator modules were placed on the power board, but as voltages have been reduced, they are now designed as separate modules that require a special high power and versatile connector with low inductance. Elcon Products introduced the mini Crown Edge system in 2003 to address this market and it has now been expanded to include a highly

## Troubleshooting tool enables designers to test HSDPA



Companies throughout the mobile industry are reporting increases in infrastructure spending. As a result, manufacturers are working on designs that will enable the acceleration of next-generation devices and networks. HSDPA (high speed downlink packet access), one of the latest next-generation technologies has the potential to extend third generation (3G) capabilities to enable an all IP network that merges wireless and wireline infrastructure by significantly enhancing peak data rates, quality of service and spectrum efficiency. To meet designer's requirements to test HSDPA designs today, Tektronix added an HSDPA test suite to its WCA200A series of wireless communications analysers.

Tektronix  
www.tektronix.com

practical mix of signal and power contacts. The mini Crown Edge is a true power interconnect which enables it to meet the high power requirements of modern VRM applications. With low profile contacts with a short path length ensuring low loop inductance levels, it is available in several form

factors to suit different applications. In its standard form it features 12 individual and isolated power contacts and 18 signal contacts in a package that is less than 4 inches long. Two latches hold the VRM to the connector and are robust enough to accommodate 1U and 2U VRMs.

Elcon Products  
www.elcon-products.com

## Free guides to EMC standards offered to visitors to the EMC UK 2004 Exhibition

Technical guides published to provide easy to understand and impartial advice about the new EMC standards and related issues will be available free of charge at the REO stand at this years EMC UK exhibition. Guides will be available to visitors who will have the opportunity to subscribe to the entire series of new REO mini guides, released monthly. There are 17 in all. The series has been well received by test, electronics and design engineers. Practical advice addresses standards and electrical power quality topics, which are called up the the CE Marking Directives and relate to EMC phenomena. They cover a range of specific areas including harmonics, voltage sags, dips and interruptions, magnetic field immunity, electrostatic discharge, RFI, surges and voltage variations. The EMC UK 2004 Exhibition, 12 - 13 October

REO  
www.reo.co.uk



**Do you have an interesting product?**

Contact  
Steve Morley  
Group Sales Executive

Tel: 01322 611254  
Fax: 01322 611339

## Tek sampling scope breaks barriers

Tektronix have announced the introduction of a modular sampling oscilloscope - the TDS8200 and the 82A04 phase reference module, which will enable design engineers to characterise and validate performance of leading-edge products.

The new oscilloscope can be configured to provide bandwidth to 70GHz, and is the only single-ended and differential clock recovery system covering all current and emerging serial data standards between 50Mbit/s and 12.6Gbit/s. The unit offers an industry-best system jitter of less than 200 femtoseconds (RMS) at these data rates.

The improved measurement system fidelity can eliminate false test failures and enables more accurate characterisation of design tolerances, resulting in increased component performance and reduced costs. The unit acquires data up to 25 times faster than competing solutions while measuring in low-jitter timebase phase reference mode. Using FrameScan(tm), an acquisition mode exclusive to Tek, the TDS8200 also provides the ability to measure random and deterministic jitter. With these new oscilloscope features, engineers are better able to perform accurate, repeatable compliance testing of high-speed, low-power differential signals with the capability to trigger on embedded clocks, facilitating the creation of new leading-edge products.

Tektronix  
www.tektronix.com



Please quote *Electronics World* when seeking further information

## Fume & dust extraction equipment manufacturer promotes service team on CD

The strength in depth of Nederman UK's growing Service Department is clearly illustrated on a new CD. The 10-strong department, comprising office-based staff and a team of regionally based engineers across England and Scotland represents a substantial investment which is the country's leading specialist fume and dust extraction equipment manufacturer. In combining a high level of

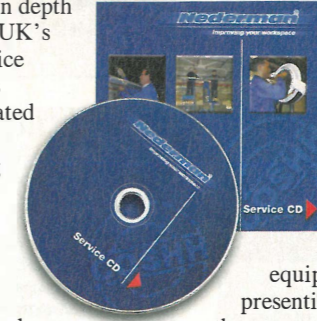

experience with sophisticated CRM systems, the Nederman team can also provide preventative maintenance in a service offer that also covers non-Nederman

equipment. Whilst presenting a clear picture of the support Nederman offers, this new CD also highlights LEV testing which takes the user through current LEV and COSHH legislative requirements. Copies of the CD are available from Nederman UK  
www.nederman.co.uk

## EM simulation cuts cost of protective MRI enclosures

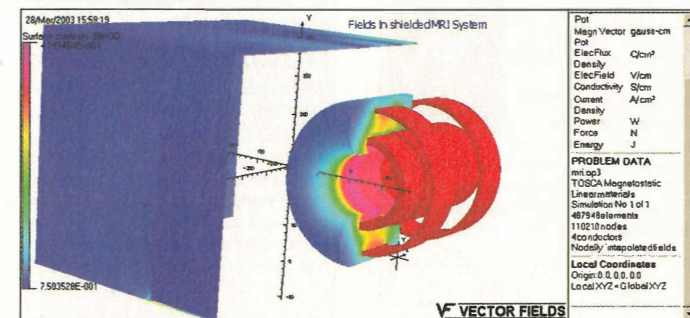

Electromagnetic simulation substantially reduced the cost of the protective shields surrounding magnetic resonance imaging (MRI) suites at one Chicago hospital. Use of 3D EM simulation software from Vector Fields enabled engineers at Lindgren RF Enclosures Inc. to quickly evaluate different shield materials and thicknesses to achieve the desired level of protection at the lowest price. Also by using simulation as part of the design process they were able to ensure that the shields would provide adequate protection prior to installation. Not only did the software

package enable Lindgren to optimise several systems for the same hospital, but also assisted in the initial purchase evaluation by being able to quantify costs, build schedules and many other aspects of different types of machine.

The software simulation package from Vector Fields is designed for analyses of any EMI screen currently essential under EEC regulations for all equipment generating radio frequency and electromagnetic fields. Further information on all software packages is available from Vector Fields  
www.vectorfields.com

## LED light beam could save third world lives

Anaemia causes the deaths of around 50,000 third world women a year during childbirth, it impairs mental development in young children and is lowering national IQs with an estimated loss of 2 per cent of GDP in the worst affected countries, according to a UNICEF report earlier this year.

A new device, Anaemascan, has been developed which simply shines an LED light beam through a blood sample and measures the amount of haemoglobin in the blood. Invented by engineers at Bath Institute of Medical Engineering (BIME) it has been patented by Matthew Gillard from the Bristol office of Withers & Rogers.

The new electronic Anaemascan provides a simple system of detecting anaemia with ease. Its accuracy compares with that of a laboratory, but it is mobile and much less expensive, so will be invaluable to third world and disaster/war torn countries.

A manufacturing company - Norwood Instruments Limited in Huddersfield has been licensed to produce and market the Anaemascan.

Withers & Rogers,  
www.withersrogers.com





# WEB DIRECTIONS

To reserve your web site space phone Steve Morley  
Tel: 01322 611254 Fax: 01322 611339

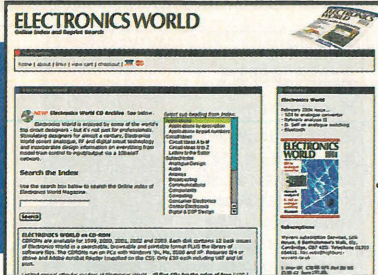

Put your web address in front of 18,000 electronic fanatics. *Electronics World* acknowledge your company's needs to promote your web site, which is why we are dedicating 2 pages in every issue to **WEB ADDRESSES**.

Linage only will cost £150 + vat for a full year.

Linage with colour screen shot will cost £350 + vat for a full year, this will include the above plus 3cm shot of your web site which we can produce if required.

To take up this offer or for more information telephone

Steve Morley  
Tel 01322 611254

E-mail  
s.morley@highburybiz.com

**CHYGWYN**  
www.chygywyn.com

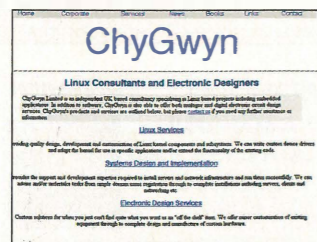

ChyGwyn Limited offers electronic design and embedded software development for remote monitoring, embedded appliances, set-top boxes and similar devices. We are experts in customisation of Linux and write device drivers for custom hardware.

**COMPONENT TECHNOLOGY**  
www.componenttechnology.co.uk



- PIC microcontroller kits and modules for students and hobbyist.
- 18F45X, 16F87X Proto-Boards for ease and fast development of project ideas.
- Infrared Illuminators for CCTVs in low ambient light security areas.
- Analogue 8-channel high voltage isolator. Data logging.
- 5% discount code 'elwwdir2004' for Electronics World readers.
- Consultancy
- TIG control systems – REIS interface.
- Real-time X-ray Imaging.

**CONFORD ELECTRONICS**  
www.confordelec.co.uk/index.shtml

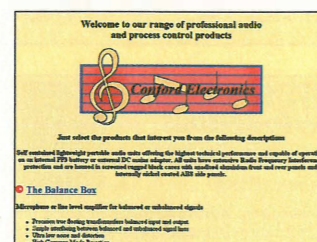

Lightweight portable battery/mains audio units offering the highest technical performance. Microphone, Phantom Power and Headphone Amplifiers. Balanced/unbalanced signal lines with extensive RFI protection.

**CRICKLEWOOD ELECTRONICS**  
www.cricklewoodelectronics.co.uk



Cricklewood Electronics stock one of the widest ranges of components, especially semiconductors including ICs, transistors, capacitors, all at competitive prices.

**DB TECHNOLOGY**  
www.dbtechnology.co.uk/  
EMC Testing and Consultancy.



- Anechoic chamber and open area test site.
- Compliance Tests
  - Rapid, accurate pre-compliance tests.
  - Fixes included. FCC Listed.
  - Flexible hourly booking available.

**DESIGNER SYSTEMS CO**  
www.designersystems.co.uk



Electronic product design company with over a decade of experience promoting its own product range and designing and manufacturing innovative products for client companies/individuals.

**FUTURE TECHNOLOGY DEVICES INTL. LTD.**  
www.ftdichip.com



FTDI designs and sells USB-UART and USB-FIFO interface i.c.'s. Complete with PC drivers these devices simplify the task of designing or upgrading USB peripherals

**GREENWELD**  
www.greenweld.co.uk



Whether your interest is in electronics, model engineering, audio, computer, robots or home and leisure products (to name just a few) we have a wide range of new and surplus stock available.

**MCES Ltd**  
Web: www.mces.co.uk

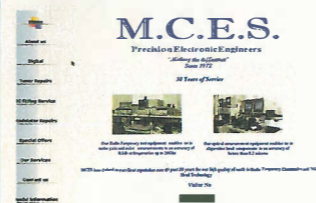

MCES are a specialist electronics company providing a high quality repair, rework and re-manufacturing service to electronic modules and sub assemblies, including handling both large and small volume production and rework for major manufacturers. Established in 1972 we have continued to make large investments in specialised test equipment, surface mount technology and tooling enabling us to diagnose repair and verify a wide range of electronic modules to a very high standard. We also operate a fitting service for surface mount multi pin IC's and BGA's

**QUASAR ELECTRONICS**  
www.QuasarElectronics.com



Over 300 electronic kits, projects and ready built units for hobby, education and industrial applications including PIC/ATMEL programming solutions. Online ordering facilities.  
Tel: +44 (0) 870 246 1826  
Fax: +44 (0) 870 460 1045  
Email: sales@QuasarElectronics.com

**NORCALL Ltd**  
www.tetra-com.co.uk



Suppliers programmers and repairers of new and refurbished two-way radio equipment. Retuning and recrystalling service available. All types of batteries chargers and aerials supplied.  
e-mail Norcall@aol.com

**SOFTCOPY**  
www.softcopy.co.uk

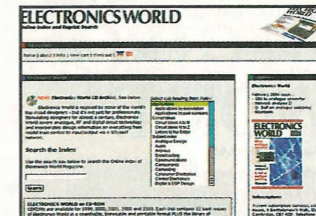

As a PC data base or hard copy, SoftCopy can supply a complete index of Electronics World articles over the past ten years. Photo copies of articles from back issues are also available.

**TELEVES**  
www.televes.com



Televes website was launched as an easier way to keep in contact with our World-wide Network of Subsidiaries and Clients. This site is constantly updated with useful information/news plus you can download info on our range: TV Aerials & accessories, Domestic and Distribution amplifiers, Systems Equipment for DTT and Analogue TV, Meters and much more.  
Tel: 44(0) 1633 875821  
email hbotas@televes.com

**TEST EQUIPMENT SOLUTIONS**  
www.TestEquipmentHQ.com



Test Equipment for rental or second user sale at the industry's lowest prices. All types of equipment from all leading manufacturers including general purpose, communications and industrial test. Items fully refurbished with 1 year warranty. Rental rebate given on purchases.

**TELONIC**  
www.telonic.co.uk

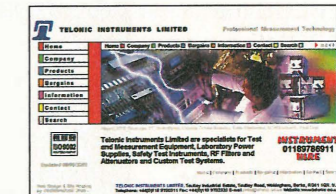

Telonic specialists in laboratory AC & DC Power Supplies, Electronic AC & DC Loads, Electrical Safety Testing and complete test systems. Plus RF Filters, Attenuators, Diesel Engine Smoke Measurement, Quartz Crystal Microbalances.  
Tel +44 (0) 118 9786911

**TELNET**  
www.telnet.co.uk



Top quality second-user Test and Measurement Equipment  
eMail sales@telnet.co.uk

**TR Control Solutions**  
www.trcontrolsolutions.com

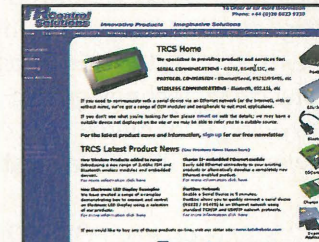

We specialise in products and services for serial communications, protocol conversion, wireless communications and embedded ethernet.  
Tel: +44 (0) 208 823 9230.

**ULTRA-CREA OY**  
www.ultra-crea.fi

Our business idea is to provide our customers complete service, i.e. design from the customer specification to the delivery of finished and tested products. Our offerings are as follows:

- RF transmission line filters from 100MHz to 3GHz
- Special antennas to frequencies as above
- Transmitter and Receiver modules
- RF-subunits such as amplifiers, oscillators, directional couplers etc.

**WILMSLOW AUDIO**  
www.wilmslow-audio.co.uk

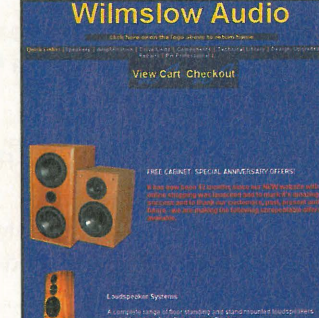

"UK's largest supplier of high quality loudspeaker kits and drive units. Comprehensive range of components and accessories, including damping products, connectors and grilles materials. Demonstration facilities available.



# ELECTRONICS WORLD

## On CD-ROM

Electronics World is enjoyed by some of the world's top circuit designers - but it's not just for professionals. Stimulating designers for almost a century. Electronics World covers analogue, RF and digital circuit technology and incorporates design information on everything from model train control to input/output via a 10baseT network.. and it's now available all on CD-ROM.

- 12 issues on each CD-ROM
- Full text and diagrams of all articles, circuit ideas, letters etc
- Easy to browse
- Fully searchable by keywords and index
- High-quality print in colour
- Full software listings included
- easy to use

CDROMS are available for 1999, 2000, 2001, 2002 and 2003. Each disk contains 12 back issues of Electronics World in a searchable, browsable and printable format PLUS the library of software files. The CDROMS run on PCs with Windows '9x, Me, 2000 and XP. requires IE4 or above and Adobe Acrobat Reader (supplied on the CD).  
**The CDROMs are only £30 each including VAT and UK post**, add £1 extra postage for Europe, £5 extra postage for rest of the world, exclusively available from SoftCopy Limited, address below.

**Limited special offer for readers of Electronics World - all five CDs for the price of four.**

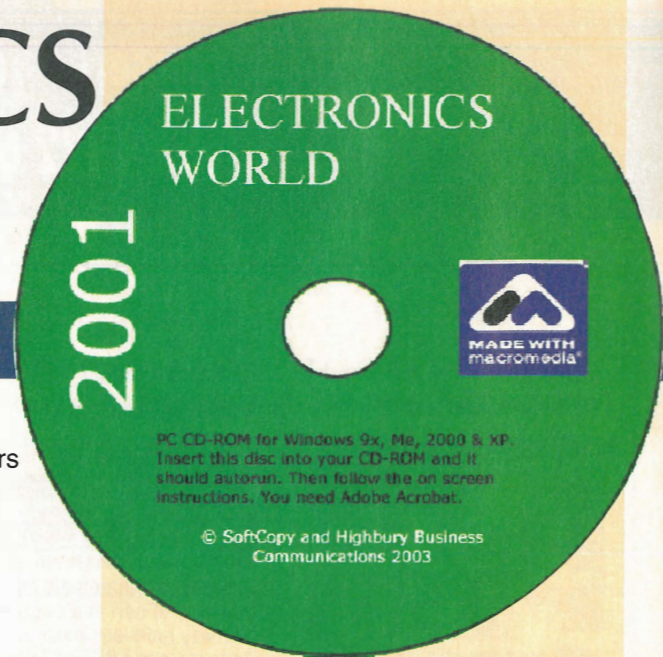

PC CD-ROM for Windows 9x, Me, 2000 & XP. Insert this disc into your CD-ROM and it should autorun. Then follow the on screen instructions. You need Adobe Acrobat.

© SoftCopy and Highbury Business Communications 2003

1999, 2000, 2001, 2002, and 2003

2002

Reader exclusive: brand new B<sup>+</sup> Spice version - save 25%!

## ELECTRONICS WORLD

JANUARY 2002 £2.95

**Class-G audio power amplifier**  
Complete design - with PCBs

**VHF direction finder**  
EMI tips and tricks  
Universal tone decoder  
Programming in real time

The month's hottest news stories - turn to page five now

**Circuit ideas:**

- Thermal core analysis
- Measuring gas concentrations
- Station direction sensing
- Latching touch switches
- Engine overhaul warning
- Optimise valve o/p transformers

JANUARY 2002

FEBRUARY 2002

MARCH 2002

APRIL 2002

MAY 2002

JUNE 2002

JULY 2002

AUGUST 2002

SEPTEMBER 2002

OCTOBER 2002

NOVEMBER 2002

DECEMBER 2002

Index    Search    Exit

© SoftCopy Limited & Highbury Business Communications 2003

Please send the following CD-ROMS

_____ qty 1999	NAME _____
_____ qty 2000	Address _____
_____ qty 2001	_____
_____ qty 2002	_____
_____ qty 2003	Card Number _____ Expiry _____

**Order now at:**

**www.ewmag.co.uk**

SoftCopy Limited, 1 Vineries Close, Cheltenham GL53 0NU, UK

Tel: +44 (0) 1242 241455 Fax: +44 (0) 1242 241468 sales@softcopy.co.uk

**WEB SITE WWW.JOHNSRADIO-UK.COM WWW.JOHNSRADIO.COM**  
**JOHNSRADIO ELECTRONICS TEST AND COMMUNICATION EQPT**  
**MASSIVE 10,000 SQ FT**  
**WAREHOUSE CLEARANCE SALE**  
**DC-MICROWAVE TO 300 GHZ - OPTICAL - LIGHT - EQPT - PARTS**  
**TEKTRONIX - HP - AGILENT - MARCONI**  
**PHILIPS - RACAL - B&K - R&S - W&G - ETC**  
*Sales Warehouse, Johnsradio, Smithies Mill, Birstal Smithies Lights, 883-885 Bradford Rd, Batley, West Yorkshire, WF17 8NN.*  
**Tel: 01924 442905 Fax: 01924 448170 E-mail: johnsradio@btconnect.com**  
 Directions M62 Junction 27, A62 to Huddersfield, 1 mile to Birstal Smithies Lights, (6 roads) left under factory chimney aerial, Smithies Moor Lane 50 YDS second left red gate.  
**HOURS M-F 9AM - 1PM AND 2PM - 5PM, SAT 9AM - 1PM**  
*Phone for appointment or to request item lists, photos, site map.*  
 All welcome, Private or trade, for sales, workshop repairs or calibration.  
**PLEASE CONTACT PATRICIA AT WHITEHALL WORKS, 84 WHITEHALL ROAD, EAST BIRKENSHAW, BRADFORD, WEST YORKSHIRE, BD11 2ER**  
**Tel: 01274 684007 Fax: 01274 651160**  
**WEB SITE WWW.JOHNSRADIO-UK.COM WWW.JOHNSRADIO.COM**

**This Magazine reaches over**  
10,000  
 potential customers

**To advertise in this space call**  
**Steve on**  
01322 611254

NEWS AND TECHNOLOGY ■ INSTALLATION ■ SERVICING ■ DEVELOPMENTS

# TELEVISION

## AND CONSUMER ELECTRONICS

**TELEVISION AND HOME ELECTRONICS REPAIR**  
FEBRUARY 2004 £3.50

**TEST REPORT: The D-GEN pattern generator**  
Sky digibox RF2 checker  
CCTV recording system

**TELEVISION AND HOME ELECTRONICS REPAIR**  
MAY 2004 £3.50

**Workshop equipment guide**

**Servicing the Philips L01 chassis**  
Simple volume compressor circuit

**TELEVISION AND CONSUMER ELECTRONICS**  
AUGUST 2004 £3.50

**Test reports: Towards the digital home**

**The Sale of Goods Act explained**  
Servicing the Hitachi A7 chassis

Television and Consumer Electronics magazine is the only magazine for technicians who deal with consumer electronic products, in particular TV, video, satellite and audio equipment.

- Launched in 1935 this respected journal is the longest established consumer electronics magazine
- Keep up to date with the latest information and changes affecting the industry
- Tips and guides on repairing television and electronic equipment including satellite receivers, PCs, monitors, VCRs, DVD, audio equipment and much more
- Essential reference and in-depth features covered monthly

**Make sure of your copy now...**

**Subscription rates for 1 year:**  
 UK £33.80 • Europe £49.00 or €92  
 USA \$104 • Rest of the World £63.50

**Subscription rates for 2 years:**  
 UK £53 • Europe £78.40 or €146  
 USA \$166.65 • Rest of the World £101

**Contact**  
 Highbury Fulfillment Services,  
 Link House, 8 Bartholomew's Walk, Ely, Cambridge CB7 4ZD.

Telephone 01353 654 431  
 Fax 01353 654 400

Email hbc.subs@highbury-wyvern.co.uk



# 2GHz full-performance RF Generator

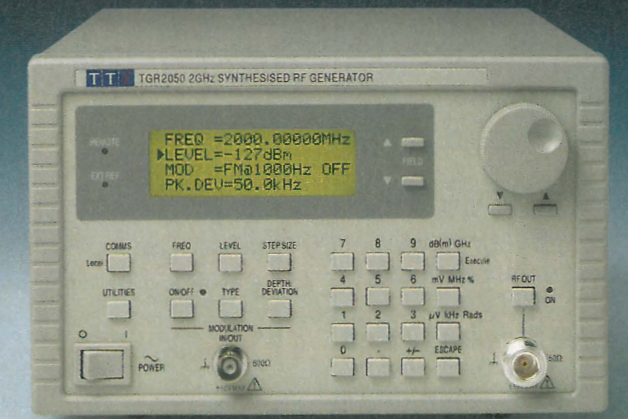

£2,195

The new TGR2050 is a synthesised signal generator with a frequency range of 150kHz to 2000MHz. Excellent frequency accuracy is matched with high stability, wide dynamic range, low phase noise and low leakage. FM, phase and AM modulation modes are incorporated along with RS232 and GPIB (IEEE.488.2) interfaces. The TGR2050 provides the most cost effective solution available for engineers needing a wide range high performance RF source.

- ▶ 150kHz to 2000MHz frequency range with 10Hz setability
- ▶ -127dBm to +7dBm amplitude range with 0.1dBm setability
- ▶ Better than 1ppm internal accuracy; external frequency lock
- ▶ FM, Phase and AM modulation, internal or external source
- ▶ Direct numeric entry or rotary control with user settable frequency and amplitude increments
- ▶ Non-volatile set-up memories for repetitive testing
- ▶ Full remote control via RS-232 and GPIB interfaces
- ▶ Unrivalled performance and features at this price level !

For applications with a narrower frequency requirement a 1GHz generator, the TGR1040, is available for around £1,200 . For full details of both generators, please contact us directly, visit our website, or circle the reply number below.



Measurably better value

Thurlby Thandar Instruments Limited  
 Glebe Road, Huntingdon, Cambridgeshire PE29 7DR  
**Tel: 01480 412451, Fax: 450409, e-mail: sales@tti-test.com**  
**Web: www.tti-test.com**

THURLBY THANDAR INSTRUMENTS

# Service Link

## ARTICLES WANTED

### TOP PRICES PAID

For all your valves, tubes, semi conductors and ICs.

**Langrex Supplies Limited**  
1 Mayo Road, Croydon, Surrey CR0 2QP  
TEL: 020 8684 1166 FAX: 020 8684 3056

## FOR SALE

### fastcomponents™

the best way to buy components

1000 pcs resistor kit £9.99  
240 pcs capacitor kit £4.99  
Brand new high quality component kits at wholesale prices!



Secure online ordering & catalog at [www.fastcomponents.co.uk](http://www.fastcomponents.co.uk)  
TEL: 0870 750 4468

### PRINTED CIRCUIT BOARDS

**DESIGNED & MANUFACTURED** **agar**  
Circuits  
• Prototype or production quantities  
• Fast turnaround available  
• PCBs designed from circuit diagrams  
• Almost all computer files accepted  
• PCB assembly - mechanical assembly  
• Full product design-manufacture-test-repair  
Unit 5, East Belfast Enterprise Park  
308 Albertbridge Rd, Belfast BT5 4GX  
TEL 028 9073 8897 FAX 028 9073 1802  
[info@agarcircuits.com](mailto:info@agarcircuits.com)

For a **FREE** consultation on how best to market your products/services to a professional audience ring **STEVE** on **01322 611254**

## SERVICES

**From Concept To Production** **48 HOUR SERVICE**

Electronic design and manufacturing services for the new millennium:

- Embedded monitoring & control
- PSTN telephones and test equipment
- Datacom interfacing, line driving etc.
- Switch Mode & linear PSU and battery management
- Gas detection systems
- Printed Circuit Board design
- Technical documentation, schematic layout & language translation
- Wireless telemetry systems
- Audio & Video processing
- GSM telemetry via SMS or data (TCP/IP)
- DVD player control systems
- GPS positioning systems
- Specialist cable looms
- Small, medium & large scale manufacturing

Email: [sales@designersystems.co.uk](mailto:sales@designersystems.co.uk)  
Tel/Fax: +44 (0) 1872 223306

**Designer Systems**  
Design & manufacturing in the UK

for more information see our web site @ <http://www.designersystems.co.uk>

### POWER SUPPLY DESIGN

Switched Mode PSU  
Power Factor Correction  
*designed to your specification*

Tel/Fax: 01243 842520  
e-mail: [eugen\\_kus@cix.co.uk](mailto:eugen_kus@cix.co.uk)

**Lomond Electronic Services**

**OPEN 6 DAYS** TV/VCR CIRCUITS (WE DO NOT STOCK AUDIO OR MONITOR INFORMATION)

TEL A.T.V. on **0114 285 4254**

CTV Circuits..... from £5.00  
VCR Circuits..... from £7.00  
CTV Manuals..... from £10.50  
VCR Manuals..... from £14.50  
User instructions also available (P/P add £2.50 to each order)

**419 LANGSETT ROAD SHEFFIELD S6 2LL**

MANUAL COLLECTIONS PURCHASED, (POST 1995)

To market your products/services to a professional audience ring **STEVE** on **01322 611254**

## WANTED

### BEST CASH PRICES PAID

FOR VALVES KT88, PX4 AND MOST AUDIO/OTHER TYPES.

Tel: 01403 784961

Billington Export Ltd  
Sussex RH14 9EZ  
Fax 01403 783519  
Email: [sales@bel-tubes.co.uk](mailto:sales@bel-tubes.co.uk)  
Visitors by appointment

### WANTED Surplus or Obsolete Electronic Components

**Turn your excess stock into instant cash!**

SEND OR FAX YOUR LIST IN STRICTEST CONFIDENCE

Will collect anywhere in the UK



**Mushroom**  
COMPONENTS

28 College Street, Kempston, Bedfordshire, MK42 8LU

Tel: 01234 363611 Fax: 01234 326611

E-mail: [sales@mushroom.co.uk](mailto:sales@mushroom.co.uk)

Internet: [www.mushroom.co.uk](http://www.mushroom.co.uk)

# Service Link

## THERE IS INTERESTING NEWS

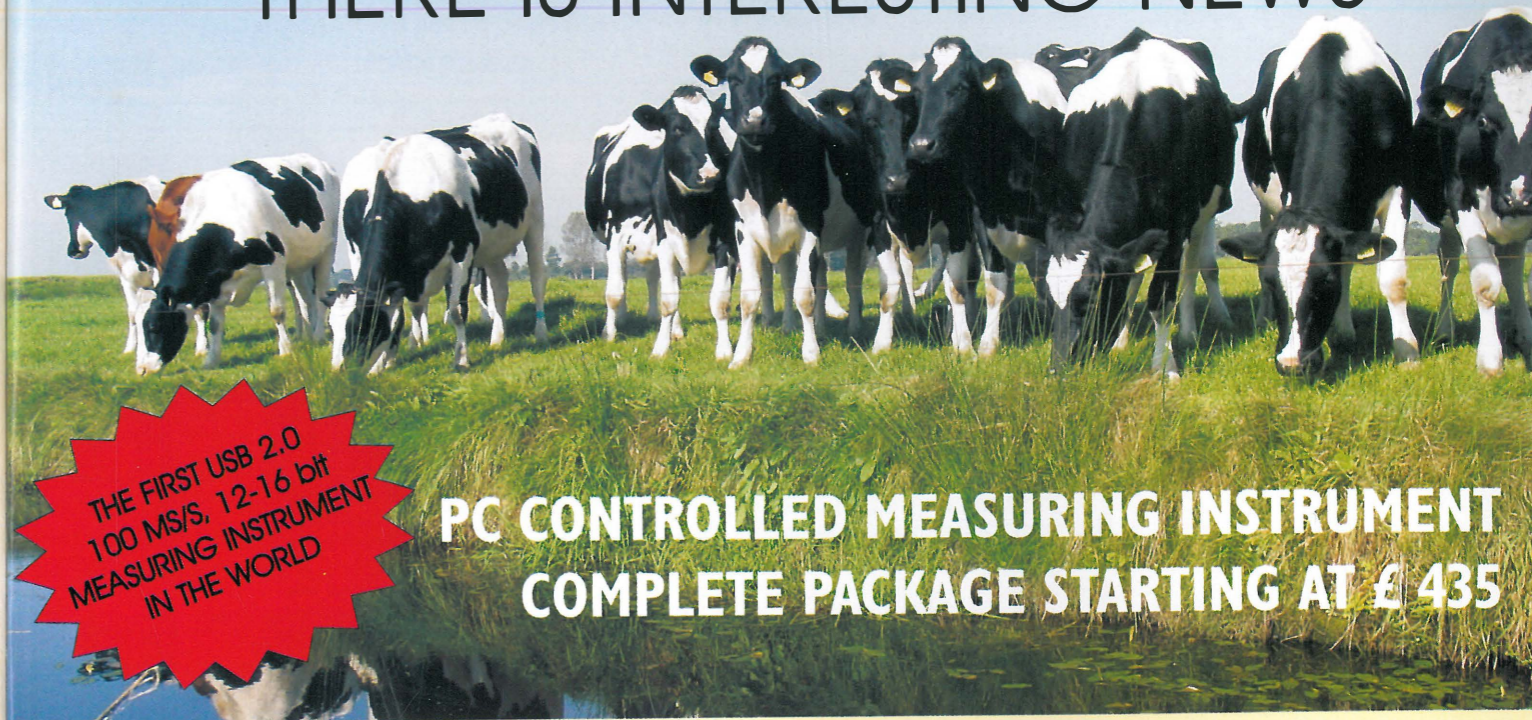

THE FIRST USB 2.0  
100 MS/S, 12-16 bit  
MEASURING INSTRUMENT  
IN THE WORLD

**PC CONTROLLED MEASURING INSTRUMENT  
COMPLETE PACKAGE STARTING AT £ 435**

OSCILLOSCOPE

FFT ANALYSER

VOLTMETER

RECORDER

The Handyscope 3 is a powerful and versatile two channel measuring instrument with an integrated function generator.

- USB 2.0 connection (USB 1.1 compatible)
- sample speed up to 100 MHz per channel
- 8 to 16 bit resolution (6  $\mu$ Volt resolution)
- 50 MHz bandwidth
- input sensitivity from 200 mV up to 80 Volt
- large memory up to 131060 samples per channel
- four integrated measuring devices
- spectrum analyser with a dynamic range of 95 dB
- fast transient recorder up to 10 kHz
- several trigger features
- auto start/stop triggering
- auto disk function up to 1000 files
- auto setup for amplitude axis and time base
- auto trigger level and hysteresis setting
- cursor measurements with 21 read-outs
- very extensive function generator (AWG) 0-2 MHz, 0-12 Volt

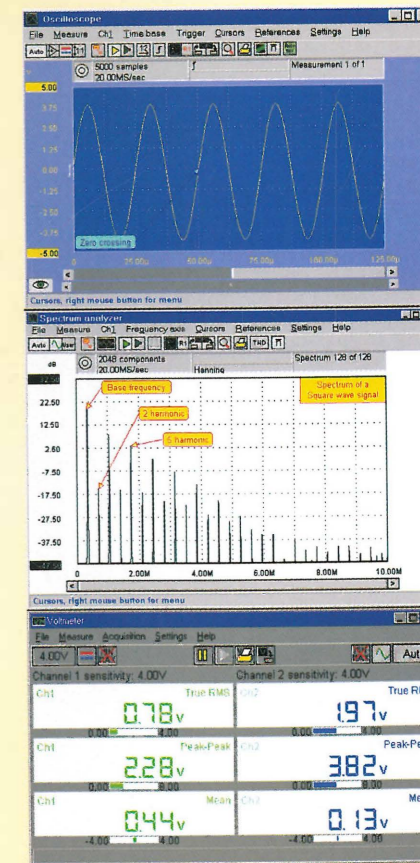

for more information, demo software, software, source code and DLL's visit our internet page: <http://www.tiepie.nl>



TiePie engineering (NL)  
Koperslagersstraat 37  
8601 WL SNEEK  
The Netherlands  
Tel: +31 515 415 416  
Fax: +31 515 418 819

TiePie engineering (UK)  
28, Stephenson Road, St. Ives  
Cambridgeshire, PE17 3WJ, UK  
Tel: 01480-460028  
Fax: 01480-460340

HANDYSCOPE HS3

WWW.TIEPIE.NL

