

The WIRELESS WORLD

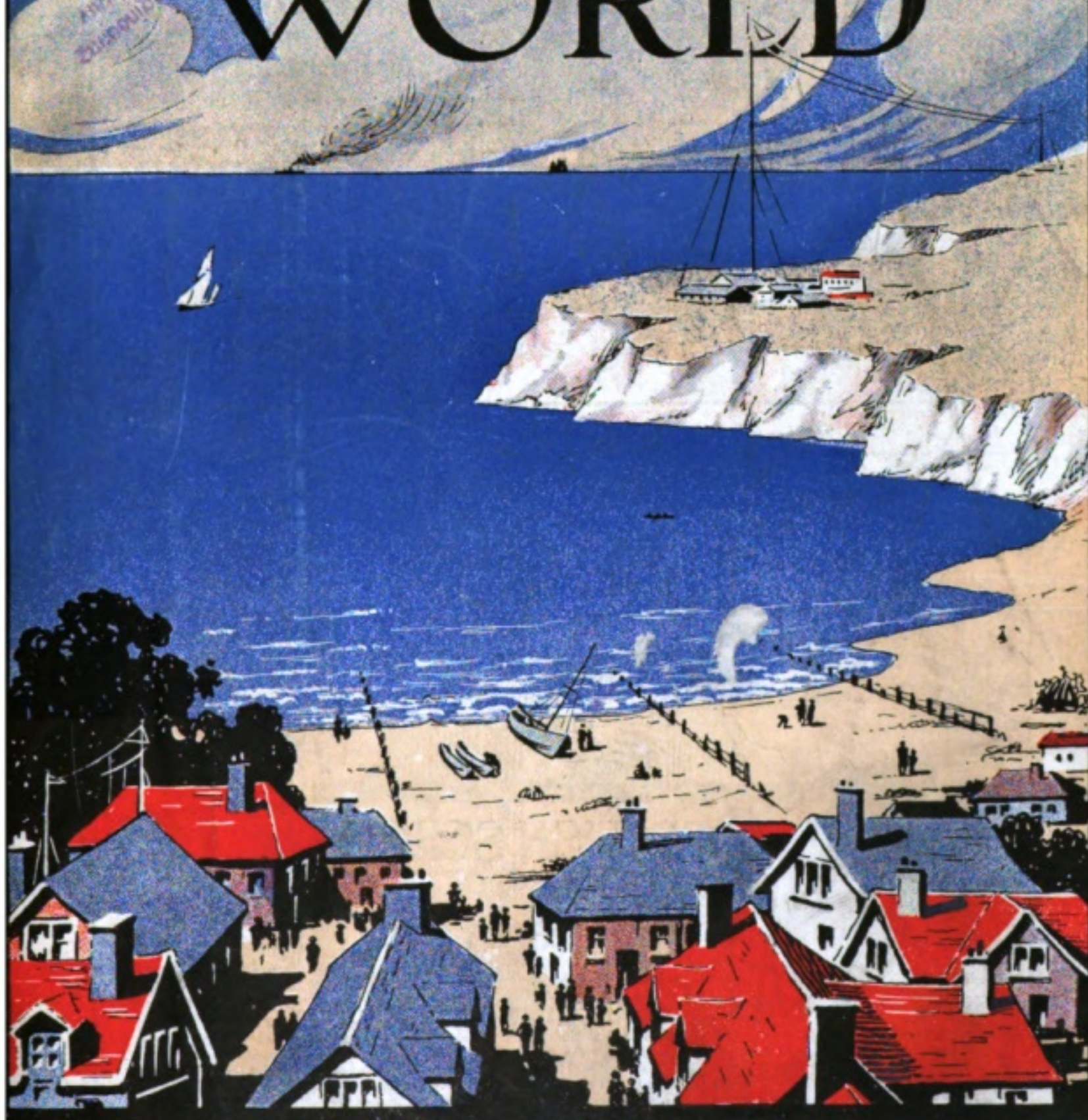

**ANTI-SULPHURIC" ENAMEL
RESISTS ACID FUMES, Etc.**

**GRIFFITHS BROS. & Co. (London) Ltd.
MACKS ROAD, BERMONDSEY, S.E. 19.**

Digitized by Google

Original from
UNIVERSITY OF MICHIGAN

SULLIVAN

PRECISION WIRELESS APPARATUS

PATENT HIGH-RESISTANCE TELEPHONE RECEIVERS 8,000 ohms. These are fitted with safety spark gap and tested up to 500 volts A.C.

TELEPHONE AND INTERVALVE TRANSFORMERS.

TRIODE VALVE GENERATORS for A.C. bridge testing.

PRECISION AND STANDARD MEASURING EQUIPMENTS for high-frequency and wireless determinations.

LONG SCALE VARIABLE AIR CONDENSERS with 360° scale, other patterns with Micrometer Adjustment, capacities: 120—10,000 micro-microfarads.

ROTARY PATTERN FILAMENT RESISTANCES, and Grid Potential Regulators, Continuously adjustable.

NON-REACTIVE RESISTANCES for A.C and H.F. Measurements.

COUPLING COILS, VALVES, ETC.

H. W. SULLIVAN, WINCHESTER HOUSE, LONDON, E.C.2., ENGLAND
WORKS: "LIVERPOOL HOUSE," MIDDLESEX STREET, LONDON, E.1.

Telegrams: "Deadbeat, Avenue, London."

Telephone: Office—London Wall 3518, Works—Avenue 4871



THE BRITISH SCHOOL OF TELEGRAPHY *Ltd.* 179, CLAPHAM R^{oad} LONDON, S.W.

EXPERT TRAINING FOR YOUNG GENTLEMEN (15—25) IN INLAND, CABLE & WIRELESS TELEGRAPHY. Good Appointments are open to our students as soon as qualified, the demand for Skilled Operators in all Services being greater than the supply. Special Short Course suitable for men wishing to obtain Government Certificate and enter the service of the Marconi Co. At several recent Government Exams, all candidates obtained 1st Class Government Certificate. No Branches or Postal Tuition. Fees moderate. Recognised by the War Office, Admiralty, Wireless Telegraph and Cable Companies.

WRITE FOR PROSPECTUS. A. W. WARD (Manager). 'Phone: BRIXTON 215

THE WIRELESS WORLD

No. 82
Vol. VII



JANUARY,
1920

Reminiscences of Wireless on the Blimp Patrol.

By MICHAEL B. EGAN.

OF all those wonderful and timely inventions which blossomed so abundantly on the prolific branches of science under the stress of warfare, few exist to-day in which we did not gladly relinquish our ephemeral interest when the joyful news of the armistice dictated our immediate return to the business of peace. Amongst those discoveries which by reason of their exceptional adaptability to the purposes of peace succeeded in retaining the interest of a war-weary people, the marvellous developments which sprang from the sciences of Aeronautics and Wireless Telegraphy and Telephony stand out boldly in the foremost rank. At a time when it was universally realized that the ultimate supremacy of the Allies demanded the immediate and complete suppression of the U-boat campaign, a necessarily captious censorship prevented the general public from fully appreciating the real value of the assist-

ance which our smallest dirigible airships contributed towards the eventual extermination of the elusive Hun. A complete account of the wonderful performances of these little Blimps (technically termed Sea Scouts or S.S. type) and of the astounding utility of the wireless apparatus which they invariably carried would provide a most fascinating volume of romantic endeavour and daring achievement.

The history of the Blimp Patrol, however, has yet to be written, and, in the meantime it will probably be of interest to readers of the **WIRELESS WORLD** to get a brief impression of the daily life of a wireless operator on one of those secluded Airship Stations which at one time dotted our coasts, from Land's End to Scapa Flow.

That factor which conduced most essentially to the enjoyment of life at an Airship Station was the absence of wet weather. In the winter, even though the prevalence of violent winds

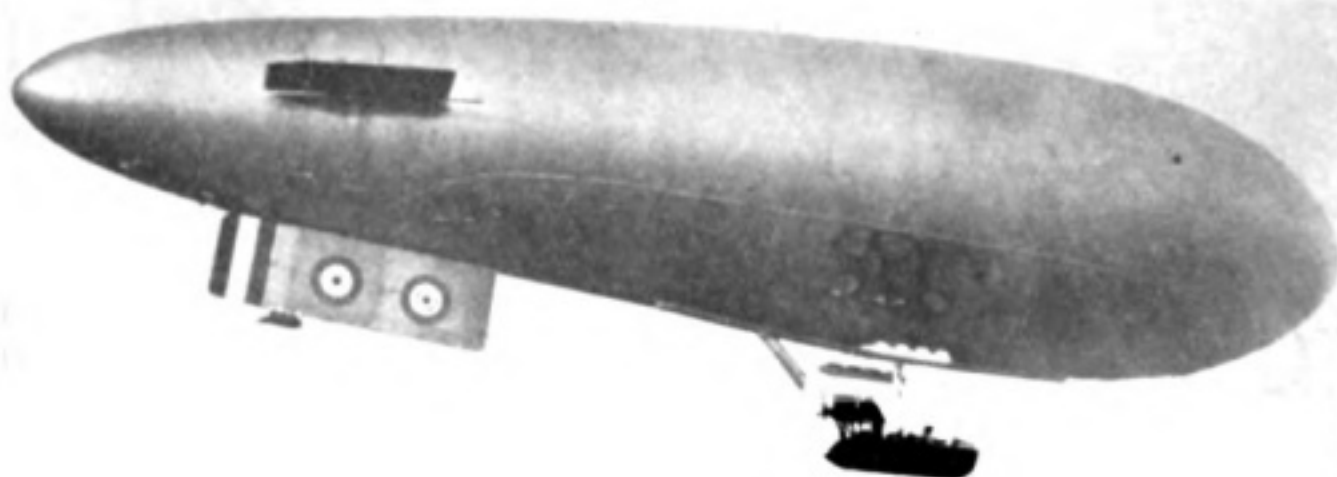

*"Z" Type Airship for Anti-Submarine Patrols.
This craft was entirely constructed at Folkestone Airship Station.*

might considerably curtail the normal amount of daily flying, so long as the ground remained dry one could with fair comfort roam around from shed to shed and derive a considerable amount of legitimate pleasure from criticising the condition of the wireless gear on all the other ships. Of course, this needed a very fine tact.

Each operator was permanently appointed to one particular ship, and it was an unwritten (though not unvoiced!) law that a visit to a brother operator's ship should at all times be preceded by a polite request. During periods of very heavy rain the approaches to the sheds usually degenerated into treacherous avenues of liquid mud, and at such times it was the custom of all operators to congregate at the Base Wireless Station (usually situated in one corner of the Aerodrome) and teach each other the *correct way* of passing a wireless message from a destroyer to a Coast Station during flight, etc. Needless to

say, these discussions invariably invoked pointed and lurid references to a multitude of *wrong* methods!

In good, fine weather life was truly delightful, and the sun-blessed days of summer were wont to tell their joyous tale all too briefly. During the summer months the launching of the early morning patrol constituted the most important event of the day, and the greatest eagerness and enthusiasm was displayed by every officer and man who assisted in getting the ships "pushed out" into the morning blue. Apart from the desire to "get on with the job" which was the motto of the Station, this spirit of cheery enthusiasm between the early hours of 4 a.m. and 5 a.m. was due in some measure to the keen rivalry which existed between all Airship Stations, particularly those within wireless range.

It was considered a matter of supreme importance that the ships from one's own aerodrome should be the *first* to "crash into the atmosphere" each day

WIRELESS ON THE BLIMP PATROL.

and salute the morning sun, and no effort was spared to achieve this worthy ambition as frequently as possible.

In addition to those operators whose ships were scheduled to fly on the early morning patrol one extra operator was detailed for duty at the Base Wireless Station in order to deal with the periodical reports which the Blimps sent back as they scoured the seas for signs of enemy activity. Every operator on the Station was obliged to officiate as duty operator in turn, and, needless to say, this was a duty whose performance gained scanty favour during bright sunny weather.

This very natural apathy frequently induced the unlucky one to attempt just another little doze after the inevitable bugle had sounded the emphatic order for the evacuation of nice warm bunks.

Thus it came to be considered that the first duty of those operators who were about to go aloft consisted in carefully depositing the unfortunate duty operator at such a distance from his bunk that the mere action of walking back should provide sufficient exertion to dispel all desire to re-enter it! This done, the next few moments were employed in testing one's telephones, donning flying kit and racing across to the sheds to make one last swift overhaul of the wireless installation.

And what a scene of activity and bustle in the shed! Busy hands are quickly unfettering the silent ships by releasing the steel wires which anchor them to the concrete floor. Meantime every part of each ship is being subjected to a swift and thorough overhaul. Solicitous mechanics see to it that there is

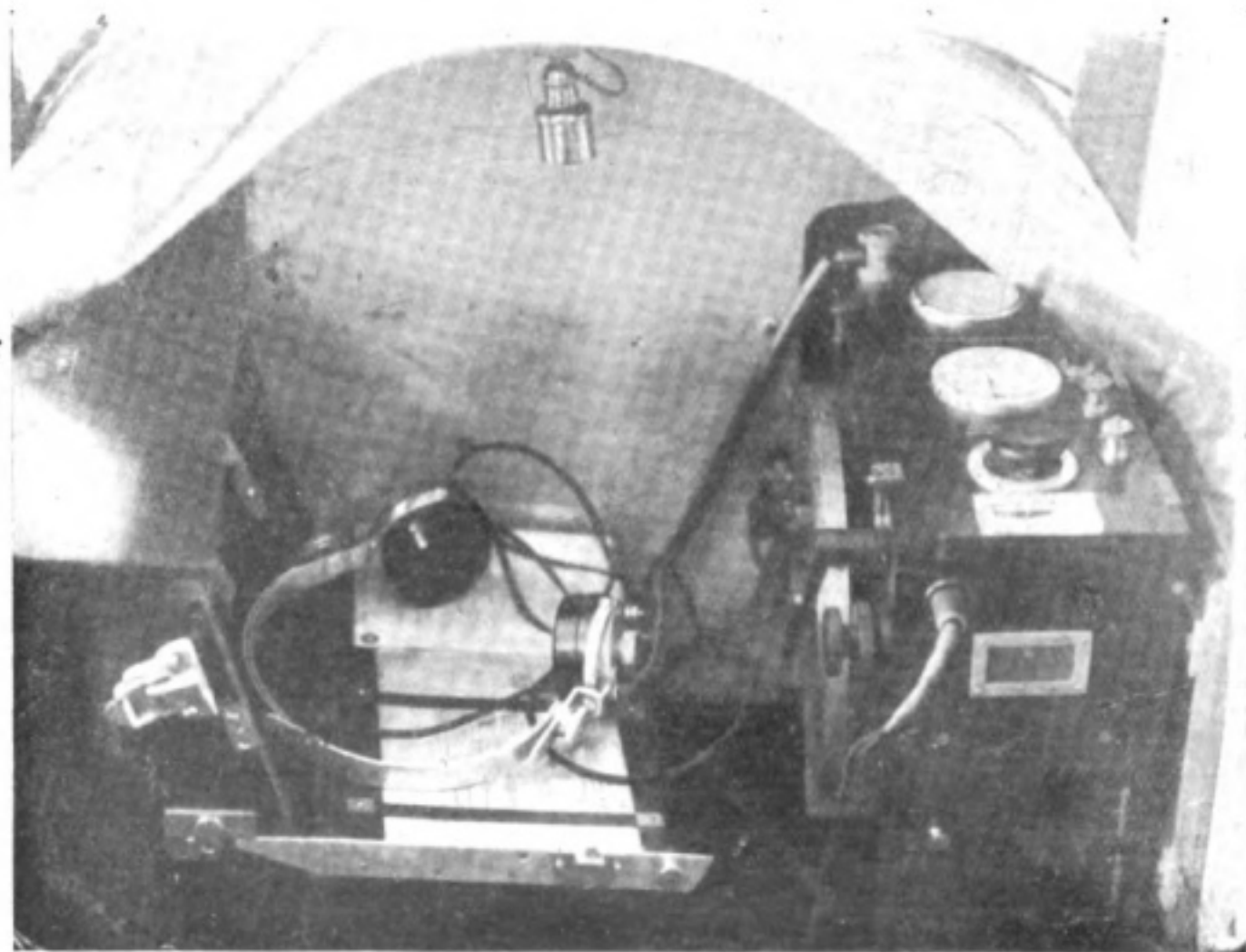

The Wireless Cockpit of a Blimp.

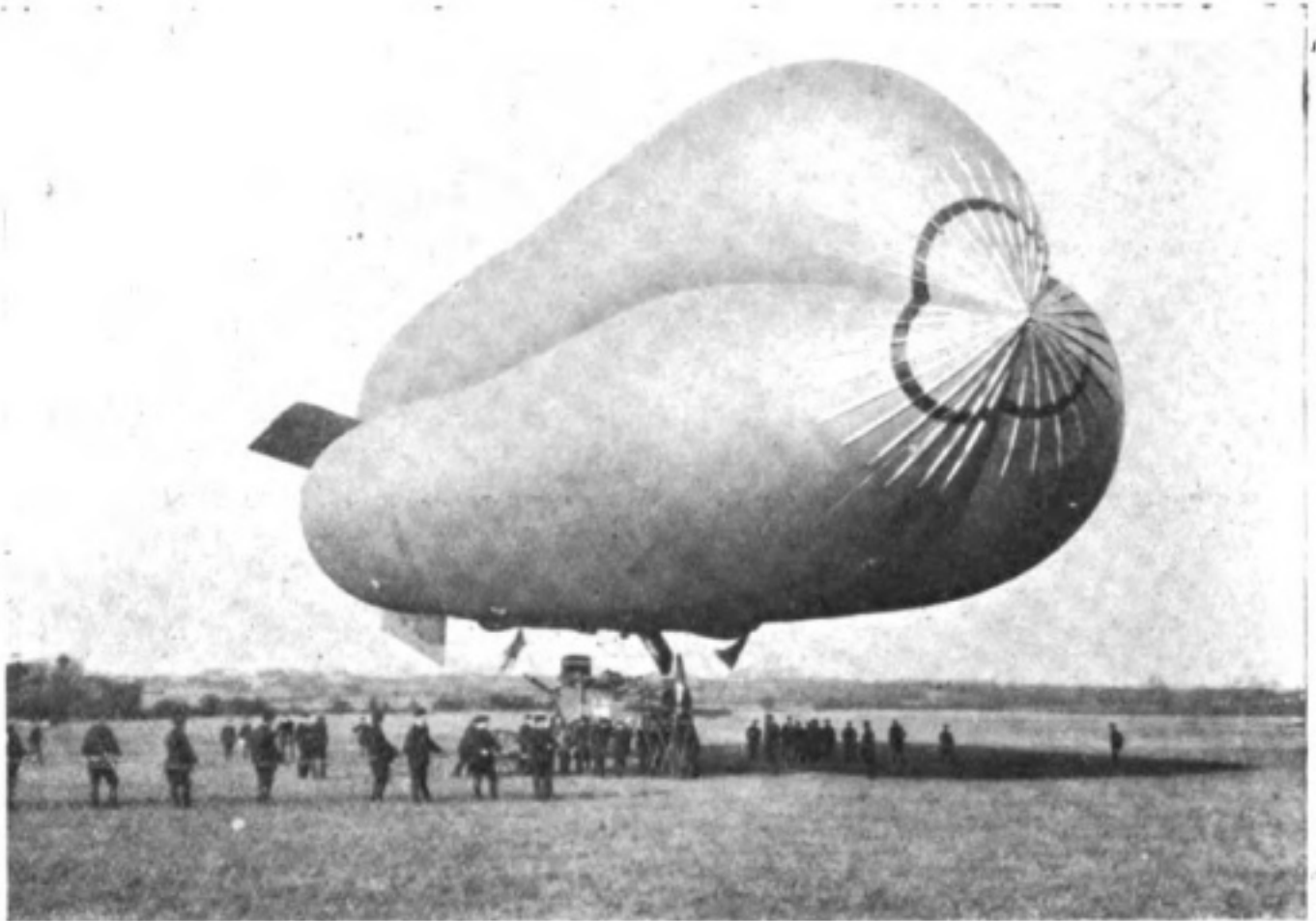

Ready for the ascent.

plenty of petrol and oil and water ballast in the tanks, fitters and riggers insure that all the controls are in thorough working order; an engineer surveys the most vulnerable parts of the engine with an experienced and critical eye; another tests the gas pressures; another checks the ammunition cargo. Presently the massive iron doors in the front of the shed are wheeled apart and the order is given, "All hands on the guys." Careful hands grip the steel guys that stretch down from the envelope of the ship, whilst others apply themselves to the removal of sand-bags from the fuselage in which the pilot is now employed in testing the air and gas pressures. In reply to the second order which follows swiftly upon the first—"Walk ship ahead"—the docile Blimp is "walked" gingerly from the shed and out on to the centre of the aerodrome. Here a halt

is called; the propellor is swung and the engine is allowed to run for a few moments whilst the pilot tests its mood.

Then "Climb up, Wireless." Up clammers the wireless operator and forthwith proceeds to adjust his instruments to the approximate valves for the wavelength on which he is about to transmit and receive. Then the final order is given. The pilot waves his hands to the party below as an indication that "all's ready." The officer in charge of the launching party gives the command, "Hands off the guys," and in a moment the silvery Blimp is mounting slowly but steadily into the tranquil blue sky of morning to the accompaniment of the engine's terrific roar. The efficiency of the aerodrome organization ensured that a very brief space of time elapsed between the departure of each ship on the same patrol, and at some station, where

WIRELESS ON THE BLIMP PATROL.

a sufficiency of personnel permitted, two or three ships could be launched simultaneously.

At the time to which reference is now made, aircraft wireless had not yet arrived at that stage of its development which was responsible for the supersession of crystal receivers by the standardised valve receivers and amplifiers of the present day. The valve, of course, was in the test rooms and laboratories on the ground, where scientific experts were employed continuously in chronicling its manifold peculiarities in the attempt to conquer the limitations which retarded its application to the purposes of aircraft wireless. But it had not yet honoured the wireless cockpit of a Blimp with its glowing presence.

In those days the complete wireless installation comprised the R.N.A.S. pattern T C Crystal Receiver which was used in conjunction with the Brown's Relay, and the Sterling Transmitter.

Owing to the extremely sensitive adjustment which was necessary for the efficient working of the Brown's Relay, this instrument was removed as far as possible from the vibration and shock of the engine. It was usually slung on elastic bands inside the tail of the fuselage, and was connected by means of a six-way lead to the Receiver and also to the low-tension batteries in the wireless cockpit which formed an auxiliary portion of its equipment.

To return to the morning Patrol. The first thing to be done when sufficient height had been acquired was to let the aerial out and call up the Base Wireless Station. This practice was adhered to in accordance with Station orders which laid down that all ships should apprise the Base Station of the time at which the patrol was commenced and finished.

Of course, in the majority of cases this was absurdly unnecessary so far as

the duty operator was concerned because, at that moment, he was probably gazing enviously at each departing ship, with his nose glued to the window of the wireless cabin, beyond which he could not go owing to the limitations of the telephone leads which effectively tethered him to his instruments! To the operator in the air, however, this practice of signalling the time of departure provided pleasant means of ensuring that his brother operator below was thoroughly and actively awake. It also gave him a welcome opportunity of testing the general efficiency of his own instrument at the outset of the patrol. No matter how much care and attention one might bestow upon one's instruments on the ground, the supreme importance of the part which wireless played in the work on hand made one naturally anxious to ascertain if any hidden fault had developed during the time which elapsed since the previous flight.

In cases where Blimp Airship Stations were situated within a few miles of the coast, the quiet fields and picturesque hamlets of the countryside were soon replaced by the broad desert of green ocean that flashed and danced away to the distant horizon beneath the warm rays of the rising sun. And now the real work of the patrol began. No object in the whole of that watery expanse was too minute or insignificant to escape a thorough scrutiny through the powerful binoculars which formed part of every wireless operator's kit. If any particular craft was too remote to permit of a definite opinion as to her friendly or hostile character the airship's course was altered accordingly until a closer survey established the sincerity of the stranger's intentions. Sometimes it was very difficult to discern objects clearly from any appreciable height above the sea. For example, the periscope of an enemy submarine and its wake did not always

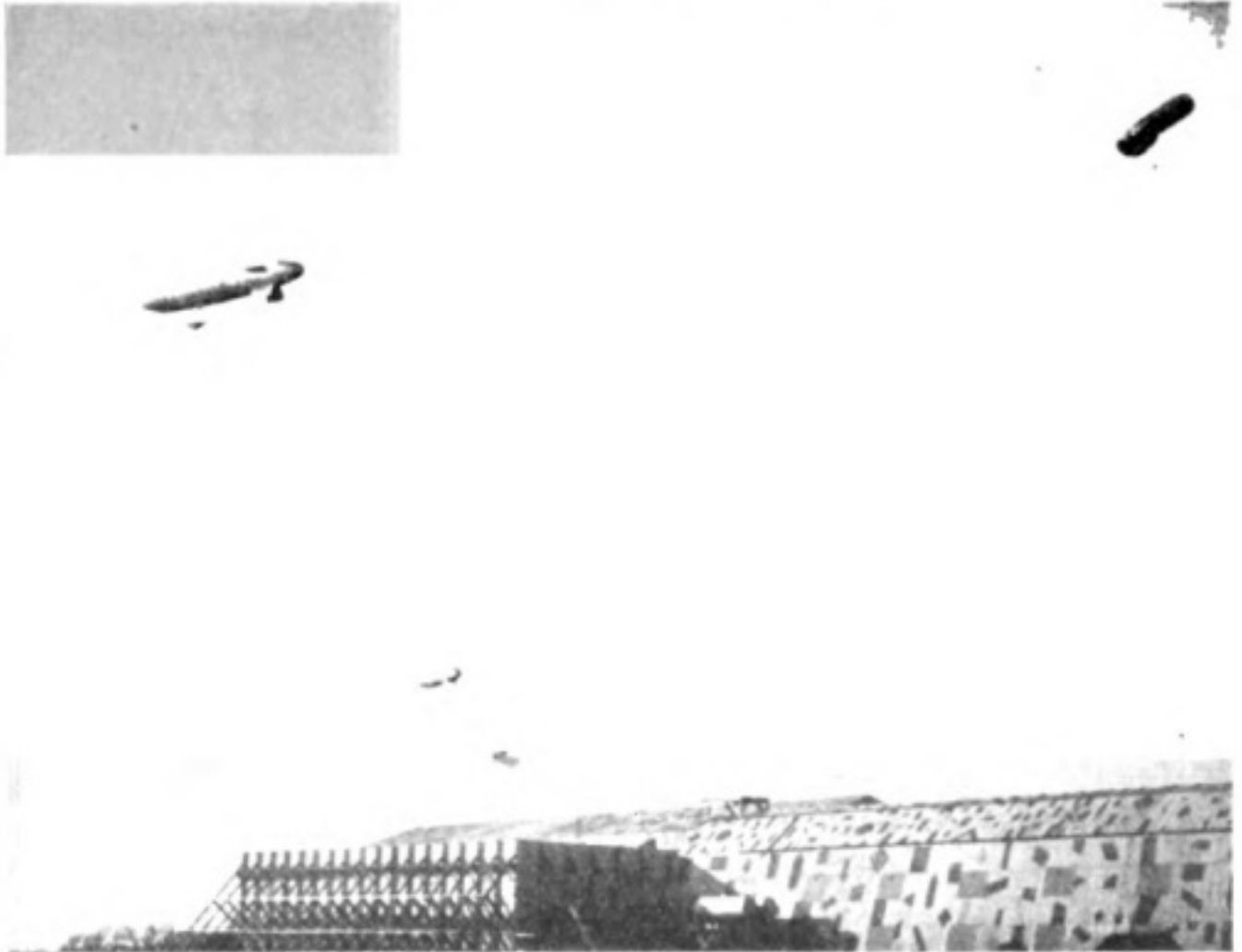

Three Blimps setting out for the day's patrol.

bear a very marked resemblance to the many fine specimens of artistic enterprise that frequently adorned our illustrated periodicals during the war. In a choppy sea the dancing and overlapping waves intermittently obscured the periscope itself and the wake of course hardly existed at all. For the purposes of war, however, doubts and possibilities and uncertainties assumed a degree of importance which was hardly surpassed by that of the realities themselves, and, in consequence had to be reported with equal celerity and precision.

The Admiralty organisation was such that at every moment of the patrol, from sunrise to dusk, the sea scouts could communicate directly with a naval base or with some vessel of the fleet which was engaged on sea patrol in the same area. Thus when enemy or even suspicious craft was observed, a

cryptic though comprehensive report was immediately flashed back to the Base Wireless Station and to the nearest naval unit, stating the exact position, course and approximate speed, etc., of the vessel or vessels which had been sighted. In this connection it must be mentioned that our Shore Wireless Directional Stations rendered inestimable assistance. These stations were usually arranged in groups of three throughout different coastal areas. All three stations were fitted with the Belini-Tosi balanced aeriels and radiogoniometer, and one station—the "control" station—was also equipped with transmitting instruments which were particularly adapted for aircraft work. Thus, in the event of being suddenly enveloped in a sea-mist or fog an airship could, by sending a pre-arranged signal, obtain its *exact* position within a very brief space.

WIRELESS ON THE BLIMP PATROL.

All wireless messages of course were transmitted in secret code and the process of coding and decoding with the promptitude and exactness which wartime operations demanded necessitated considerable practice. The code books were carried in stout covers which were weighted with lead in order that they might be swiftly consigned to the *bottom* of the sea at any moment of emergency.

Needless to say, each day's patrol did not yield signs of those wily denizens of the deep whose activities were a constant menace to our merchant shipping, and every wireless operator on the Blimp Patrol has experienced long and monotonous hours and days which brought nothing of excitement and little of fresh interest.

However, the presence of the enemy was not always the only source of excitement and on days of good visibility the proximity of a sister ship on patrol afforded a welcome opportunity for a little practice in semaphoring and flag-wagging from one ship to another. This could be performed with fair comfort by standing up on one's seat and jamming one foot firmly against the woodwork beneath the cowling which projected over the wireless cockpit. This precaution was necessary in order to maintain one's balance against the air-blast from the propeller.

With reference to this it is interesting to recall that on one or two occasions the ancient art of semaphore was employed to inform one ship that the transmitting apparatus of a sister ship had failed. In this manner the recipient of the message was able to communicate the unfortunate incident to the Base Wireless Station and thus allay the anxiety which would naturally be felt concerning the ship that had probably failed to respond to repeated wireless calls. Such an occurrence was not of course so serious as

the sudden failing of the engine. An accident of this nature was necessarily fraught with immediate danger because when deprived of her own power of propulsion an airship is converted into a free balloon without being possessed of the various facilities for descent and landing with which that type of craft is specially equipped. As it was always necessary under such circumstances for the pilot to remain at the controls, it devolved upon the wireless operator to restart the engine, and in those days this could only be accomplished by getting out of the ship and swinging the propeller from behind—it being impossible to swing it from the front whilst the machine was in the air. Not one, or two, but several operators have had the experience of obeying that cryptic summons: "Get out and swing." This was performed by climbing out on to the forward part of the undercarriage and placing one foot broadly across the left-hand skid whilst the right leg was twisted around a stout strut that sloped up to the fuselage. The right foot was jammed tightly against a cross-strut connecting both sides of the undercarriage. If possessed of a strong left arm the right hand might be employed to lend further stability to one's position by grasping one of the engine bearers. This, however, was a somewhat rare feat and the swinging of a propeller under such circumstances was usually accomplished by *leaning* against the engine bearers and utilizing both hands.

In addition to those duties which involved complete and individual responsibility for the operation and maintenance of the wireless installation, the qualifications of a Blimp wireless operator also included a thorough practical knowledge of aerial gunnery, map-reading and map-drawing, aerial photography bomb-dropping, and visual signalling in all its forms.

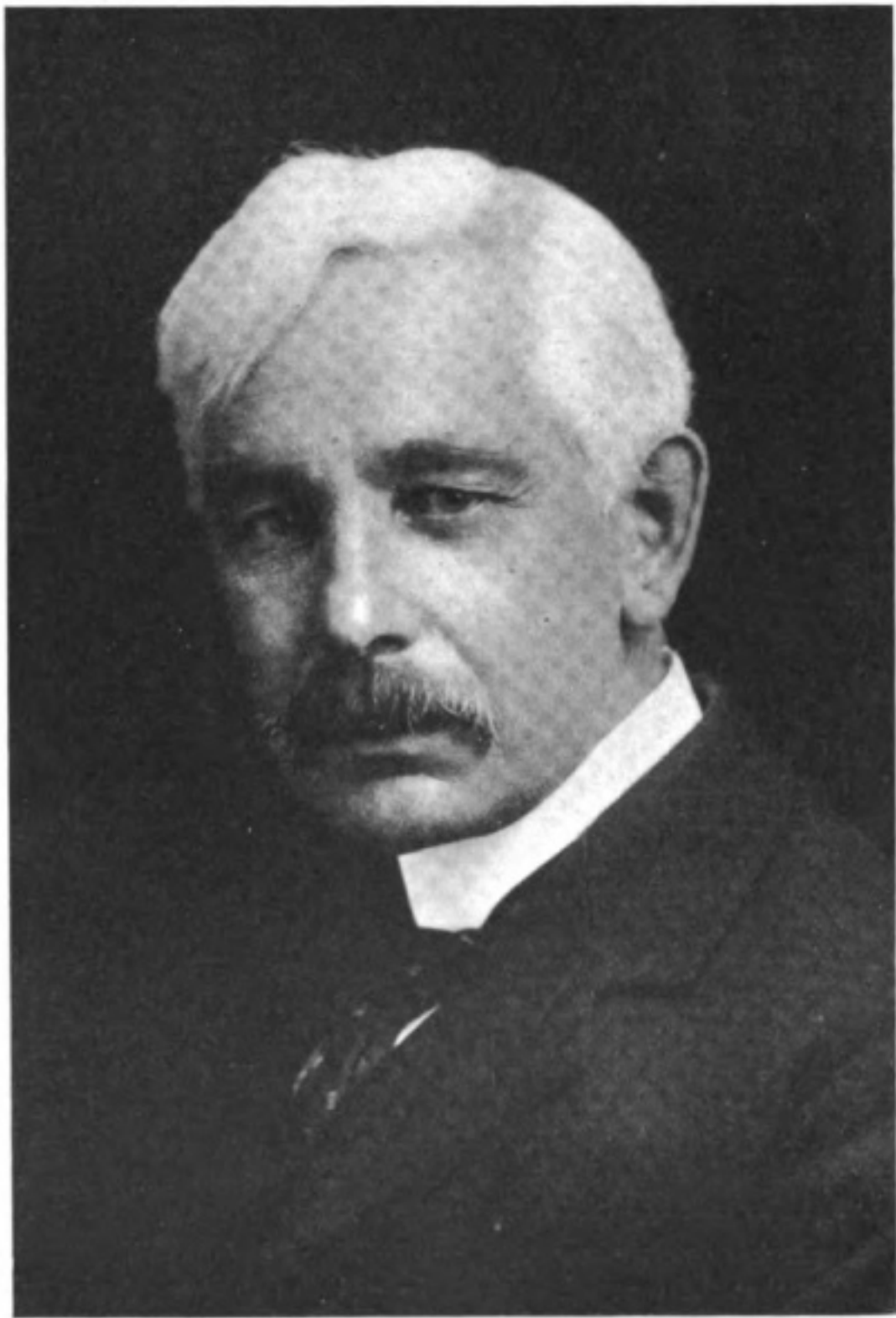

DR. CHARLES CHREE, F.R.S.

Personalities in the Wireless World

DR. CHARLES CHREE was born in 1860 at Lintrathen, Forfarshire. He received most of his early education from his father the Rev. Charles Chree, D.D., a sound classical scholar, and after staying a year at the Grammar School, Old Aberdeen, entered Aberdeen University in 1875. In those days every would-be M.A. had to attend lectures and pass examinations in English, Latin, Greek, Mathematics, Physics, Logic, Moral Philosophy, and Natural History. After the usual four years' course Dr. Chree took his M.A. degree in 1879, being first in mathematical honours. He had taken prizes in all the subjects of the curriculum and received the Medal awarded to the most distinguished graduate of the year.

Proceeding to Cambridge, he entered King's College. He took his degree as sixth wrangler in 1883, obtaining a first class in the final parts of the Mathematical and Natural Sciences Triposes. Becoming a Fellow of King's College he resided in Cambridge until 1893, when he succeeded the late Mr. G. M. Whipple as Superintendent of Kew Observatory, a post he still holds. Until 1900 Kew Observatory was administered by a Committee of the Royal Society of which Mr. F. Galton was the last Chairman. As a Meteorological Station it was subsidised by the Meteorological Office, and it possessed an endowment, the Gassiot Fund, for the maintenance of the magnetic work. Its total secured annual income being less than £900, it was largely dependent for its existence upon its verification work which continued to increase rapidly with the result that a very satisfactory financial position had been reached before the Observatory became in 1900 a nucleus of the National Physical Laboratory. In 1910 the Observatory passed under the control of the Meteorological Office to which Dr. Chree is now attached.

Since 1884 much of Dr. Chree's time has been given to research. At Cambridge, working at the Cavendish Laboratory under Sir J. J. Thomson, he investigated the thermal conductivity of liquids and some magnetic properties of cobalt. His principal work then, however, was in connection with the mathematical theory of elasticity, and he continued this work after leaving Cambridge. The practical value of some of his mathematical researches has been recognised by the award of the Watt Medal by the Institution of Civil Engineers.

Dr. Chree's responsibility for the testing work at Kew led him to publish papers on Thermometry, Mercurial and Electrical, on Magnets, on Anemometers, on lag in mercury barometers and creep in aneroids, and on the effects of reduced barometric pressure on watches.

His principal research work since 1893, however, has been in terrestrial magnetism and atmospheric electricity, two branches of physics which are closely related to the problems of wireless telegraphy, and it is the connection of these subjects with aether-wave work which probably led to his inclusion in the British Association's Committee for Radiotelegraphic Investigation. For his researches in terrestrial magnetism he has recently been awarded the Hughes Medal by the Royal Society.

Dr. Chree is a D.Sc. of Cambridge, an honorary LL.D. of Aberdeen, an F.R.S., and an ex-President of the Physical Society of London.

Notes on the Physics of the Thermionic Valve

By T. G. PETERSEN.

SUMMARY OF THEOREMS.

In order to make clearer the student's conception of the emission of electricity from hot metals in vacuo, it is proposed to summarize the kinetic theories in relation to (a) Gases, (b) Liquids, (c) Solids, and so lead up to the idea of evaporation.

THE KINETIC THEORY OF GASES.

THE molecules of all gases are continually in a state of motion in straight lines, their courses altering only when they collide with others, or hit the boundaries of the vessel in which they are contained. It will be seen from this that the walls of the containing vessel are subjected to a molecular bombardment, or the gas may be said to be exerting a pressure against the sides of the vessel. With increase of temperature but constant volume the pressure exerted by bombardment is proportional to the absolute temperature of the gas. In other words, with increased temperature, the molecules attain greater velocities, and consequently the force and frequency with which each molecule is capable of bombarding the walls of the containing vessel are increased.

THE KINETIC THEORY OF LIQUIDS.

The molecules of liquids are in constant motion, at a lesser rate than are gas molecules, but differ from the latter in that they are unable to expand or fill an unlimited space, although they are able to take up the shape of the vessel in which they reside. In other

words, there is a stronger tendency for the molecules to hold together in contradistinction to those of gases, which one may regard as having perfect elasticity, and hence, as being in contact with each other only during collision. In spite of this tendency of liquid molecules to hold together, they are evidently able to escape from the surface of the liquid, and in cases where the space around is not closely confined, may move away entirely, that is, evaporation takes place.

THE KINETIC THEORY IN RELATION TO SOLIDS.

In the case of solids the molecules are held together still more firmly, but it cannot be said that they are at rest, for even at temperatures below their melting points many solids are more or less volatile. That is, evaporation takes place, as instance the cases of solid naphtha and camphor.

EMISSION FROM HOT METALS IN VACUO.

Metals are "conductors" of electricity because there is in them an atmosphere of electrons (charges of negative electricity) in violent motion similar to the molecules of a gas. When a conductor comes under the influence of an electric field, the haphazard motion gives place to a definite direction of drift, according to the potential gradient of the field, thus constituting a flow of current. With increased heat the velocity (or energy) of these free electrons also becomes greater, and it is to be expected

PHYSICS OF THE THERMIONIC VALVE.

that some of them will become detached from the surface and move away from it. This is in fact what takes place; the mean square of the velocities of these electrons being proportional to the absolute temperature of the metal.

From the foregoing summary it will be seen that there is a similitude between the evaporation of solids and liquids, and the emission of negative electricity from metals. In short, electronic emission may be regarded as the evaporation of electricity.

REASONS FOR THE USE OF TUNGSTEN AS AN EMITTER.

In the following cases of the Thermionic Valve, it is proposed to deal with Tungsten as an emitter, and then only in relation to a pure electron discharge, such as occurs in dead-hard valves, but before passing on a comparison of Tungsten with other metals will, perhaps, not be unprofitable.

The only serious competitors with Tungsten as an emitter for Thermionic Valves are Platinum oxide-covered, Platinum-Iridium oxide-covered, and Carbon.

The prominent points for and against the previously mentioned metals may be summarized as follows:—

Platinum oxide-covered and Platinum-Iridium oxide-covered. Both of these compositions are good emitters, but fuse at low temperatures; also the degree of vacuum cannot be raised to the necessary value in their presence (see later remarks). The Oxides referred to are those of Calcium, Barium and Strontium.

Carbon. Although Carbon is an efficient emitter, its structure is such that when raised to temperatures essential to ensure sufficient emission, particles of the filament are thrown off vigorously, resulting in its rapid destruction.

It will be well, at this juncture, to point out that in valves employing a pure electron discharge it is necessary (1) to attain an exceedingly high degree of vacuum, and (2) to maintain such degree of vacuum.

(1) During the evacuation of the bulb it is essential to treat the anode to remove (as will be explained later) the gases occluded in the metal parts, and this process puts the filament to a severe test, under which all the substances mentioned, with the exception of Tungsten, would succumb before the gases had been liberated.

(2) If it were possible to remove all traces of gas from the metal parts before inclusion in the bulb, and assuming that merely by exhaustion the necessary degree of vacuum could be obtained, such vacuum could not be maintained in the presence of the oxide-coated metals named when they are heated to a temperature high enough to ensure anything like a sufficient emission. This is especially true in the case of oxide-covered Platinum filaments, and is due to the emission from the hot oxides of various vapours which of course lower the vacuum.

In Tungsten many of the faults of the substances discussed are absent. It has a high melting point (3270°C); its tendency to evolve Tungsten vapour is small even at the highest temperatures. Thus the loss due to material evaporation is little, even when it is maintained at high temperatures for long periods, whereas all impurities will quickly evaporate and be taken away during evacuation. The emission from it is steady for constant filament temperature, and it acts as a self-purifier, attacking all except the inert gases and forming compounds with them. The emission per centimetre length of filament is small, compared with that of other metals, but this de-

iciency is compensated for by its numerous good qualities.

It should be noted that pure Tungsten is rarely used in valve manufacture, the Tungsten of filaments usually containing a trace of Thorium. Pure Tungsten filaments have a decided tendency to sidestep or stagger, thereby becoming very fragile. The inclusion of Thorium rectifies this defect to a large extent.

ACTUAL CASES OF EMISSION FROM TUNGSTEN.

Having briefly shown why Tungsten is found as the emitter in present-day valves, it is now proposed to show how values of emission currents may be determined.

The emission from a filament in a high vacuum may be calculated from Langmuir's $\frac{2}{3}$ power law, namely:—

$$i = 14.65 \times 10^{-6} \frac{l}{r} (V)^{\frac{2}{3}} \text{ ampères.}$$

where, i = plate current

l = length of filament (cms)

r = radius of cylindrical plate (cms)

V = applied voltage.

Now the current in a valve is limited on two accounts:

(1) The fact that there is a limit to the rate of supply of electrons dependent upon the temperature of the filament.

(2) The effect of the space charge, which partially annuls the electric force tending to drive the electrons across the space between filament and plate.

In the above equation the space charge effect is the only one of these two considered. That is, the filament temperature is raised until the valve current is limited by the space charge. Under this condition it should be noted that

(a) with increase of filament length (l) the emission current will increase.

(b) with decrease of the distance (r) between filament and plate, the emission will increase.

(c) with increase of voltage (V) the emission current will increase in proportion to $V^{\frac{2}{3}}$ up to a certain limit.

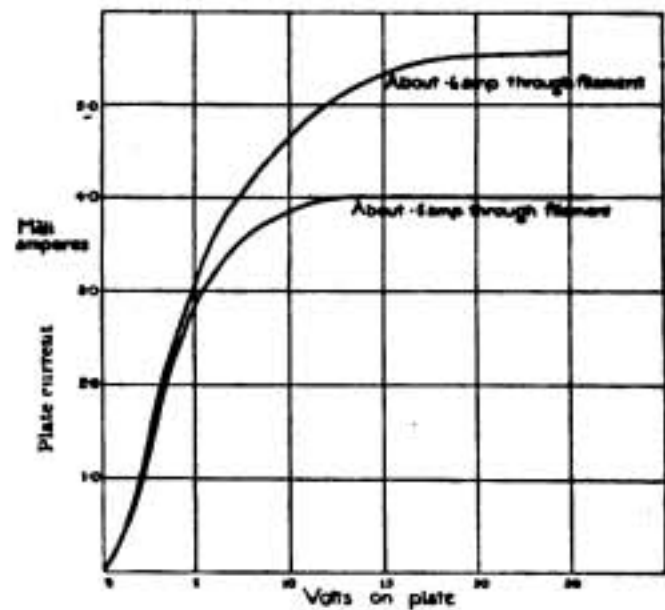

Fig. 1.

Fig. 1 shows the values of plate current obtainable in a small type receiving valve at the voltages indicated.

In Fig. 2 will be seen the values of plate current obtained in a medium power transmitting valve, with a constant voltage on the plate and with an increasing filament temperature.

It should be noted that in these two cases the plate and grid were connected.

It will perhaps be of interest to see how the transmitting valve case compares with the above equation. The constants of this valve are $l=12$, $r=0.875$, $V=200$; substituting, we obtain $i = 14.65 \times \frac{12}{0.875} \times 2,830 = 567,000$ microamperes roughly, or 567 milli-amperes, which approximates to the actual saturation value as shown in Fig. 2.

THE EFFECT OF INTRODUCING A GRID.

Having discussed some of the underlying principles governing the production of thermionic currents in a two-electrode valve, it is now proposed to outline the effect of introducing a

PHYSICS OF THE THERMIONIC VALVE.

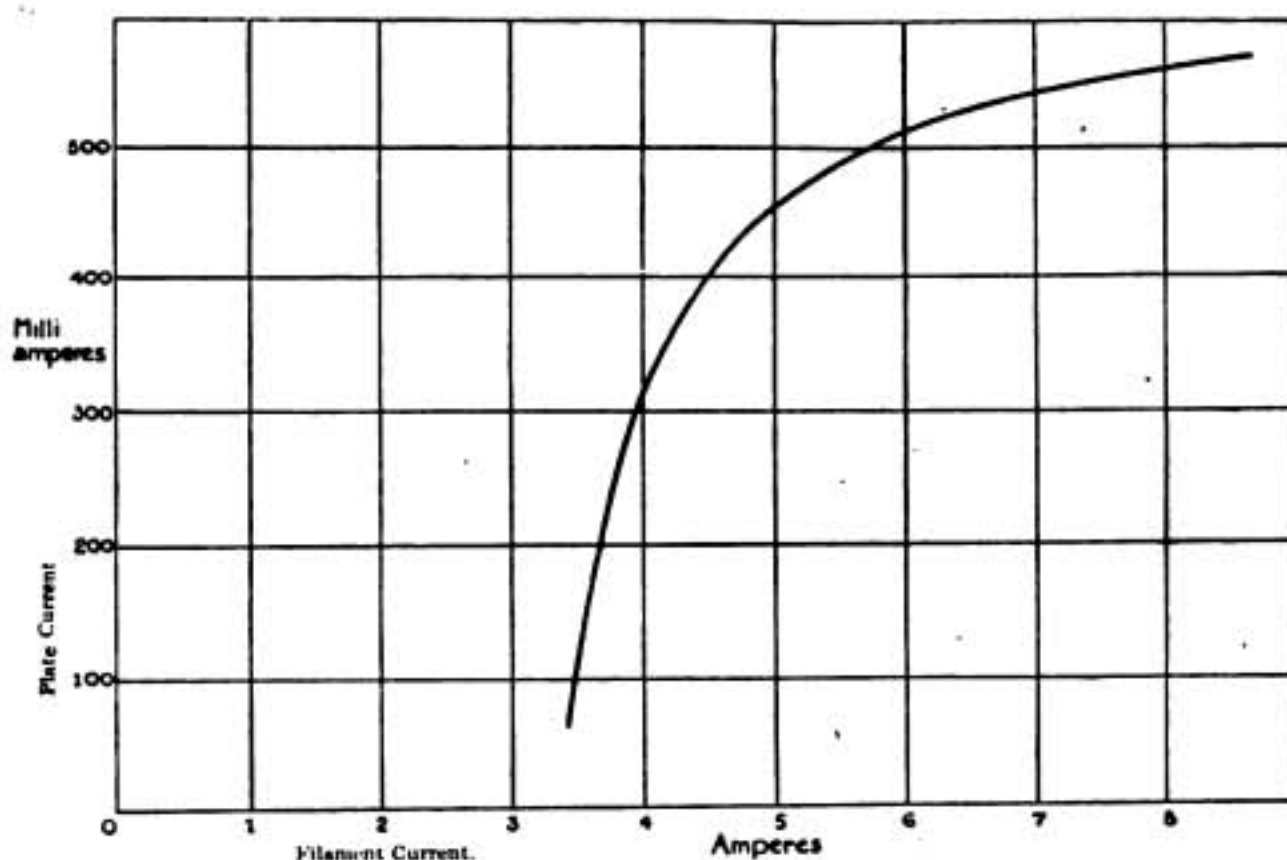

Fig. 2.

third electrode—the grid—interposed between the plate and filament.

In Fig. 3, the circuit arrangement which is to be considered, the grid is shown as a broken line G, P and F representing the anode (or plate) and the filament respectively. Also let E_B represent a battery maintaining P at a positive potential, and E_C a battery capable of being reversed and varied in its E.M.F.

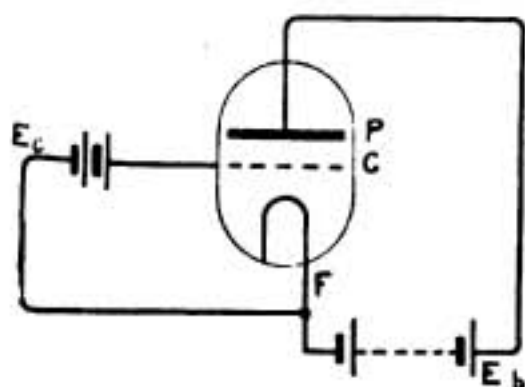

Fig. 3.

Now, for the moment, regard the grid as being connected directly to the negative end of the filament (*i.e.* with E_C absent) then its potential with respect to the filament will be zero. Although there is no difference of

potential between G and F, there yet exists an electric field between them due to E_B , setting up a field at P, which, acting through the openings of the grid, has an attractive force upon electrons in the vicinity of F. This means that G must assume a potential difference with regard to F in virtue of its position between P and F. This will be readily seen by reference to Fig. 4, in which the disposition of the electrodes F, P, and G (which, it is assumed, has a mesh the openings of which are infinitely great) are shown, and the gradient of the electric field set up by E_B between P and F, is represented by the sloping line P'F.

Now if the height E_B is proportional to the voltage of the plate battery, the

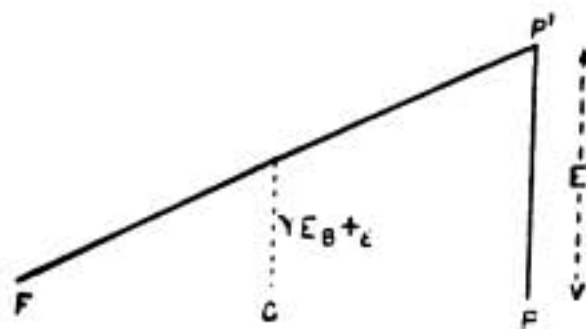

Fig. 4.

effect of the stray field of E_B acting through the apertures of the grid, on an electron in the vicinity of F , is the same as if an E.M.F., equal to the height of the line G , were acting at G towards F . The value of this potential has been shewn to be equal to

$$\gamma E_B + E^*$$

where γ is a constant dependent on the mesh and position of G and varies between unity (when the mesh of the grid is infinitely great) and zero (when the mesh of G is very small) and E^* is a constant dependent upon several factors but is negligible in comparison with γE_B . Therefore, calling the effect of the stray field at G , E_s , we have the expression

$$E_s = \gamma E_B$$

It should be pointed out that the consideration of the hypothetical case above is somewhat misleading on one point, namely, that since γ is unity, γE_B will be equal to E_B which could not be true.

G at zero potential and mesh of grid a finite size.

Take now the case where γ is somewhat less than unity—when the mesh is of finite dimensions—then the field due to E_B will be impeded in its action through the mesh of G , and the value of the stray field E_s will be decreased as illustrated in Fig. 5.

G at zero potential and mesh of grid very small.

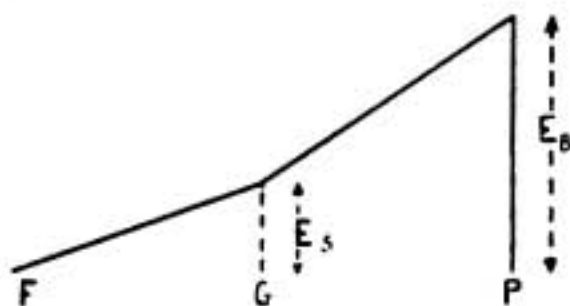

Fig. 5.

Further, if the mesh of the grid G be made very small, γ becoming zero, the strong field E_s will be nil, because E_B will be unable to operate through the openings of G . Since the electron-

attracting effect towards the grid is entirely due to E_s it will be obvious that no current can flow through the tube. This case is illustrated in Fig. 6.



Fig. 6.

These illustrations will have made clearer, it is believed, some of the effects of the insertion of the grid, in so far as it affects the plate current, also that it is theoretically possible completely to cut off the flow of electrons through a three-electrode valve even when the grid is not at a negative potential with respect to the filament.

The effect on the plate-current-grid potential characteristic, of decreasing the mesh of the grid (or increasing the number of turns in the case of a spiral grid), is to move it bodily to the right into the region of positive grid potential.

Returning to the more practical case where the value of γ is somewhat less than unity, let us discuss the condition where the grid is maintained at (a) a positive and (b) a negative potential due to the battery E_C .

(a) E_C positive, but less than E_B .

Disregarding E_C for the moment, the field from E_B will be impeded by reason of the mesh of G , and the stray field may be represented by the whole of the line G in Fig. 7, but the grid has a field acting on F independent of E_B , which is due to E_C , and being positive

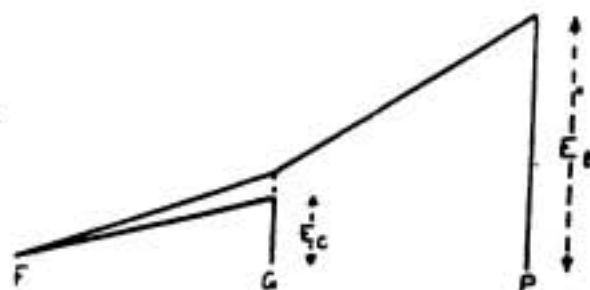

Fig. 7.

* Proc I.R.E., April, 1919.

PHYSICS OF THE THERMIONIC VALVE.

in sign assists the potential γE_B . The effect of these two positive E.M.F.'s is to set up a stronger field, which is equal to the line G, as depicted in Fig. 8. Thus with E_C positive the value of the stray field between G and F is represented by

$$E_s = \gamma E_B + E_C.$$

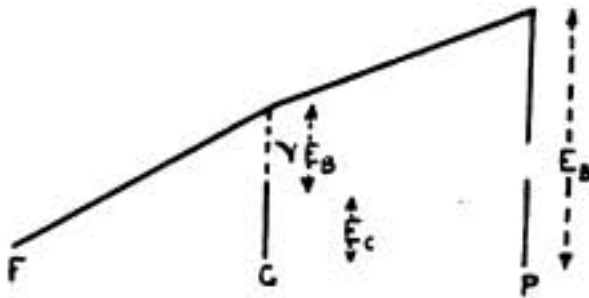

Fig. 8.

(b) E_C negative, but less than E_B .

When the grid battery E_C sustains G at a negative potential with respect to the filament, the case is different, since, as will be apparent, there will be an electric field set up which is in opposition to that due to E_B . Suppose E_C to be negative, but less than the value γE_B , then the field attracting electrons from the filament will be the same as if a potential equal to $\gamma E_B - E_C$ were given to the grid as is shown in Figs. 9 and 9a.

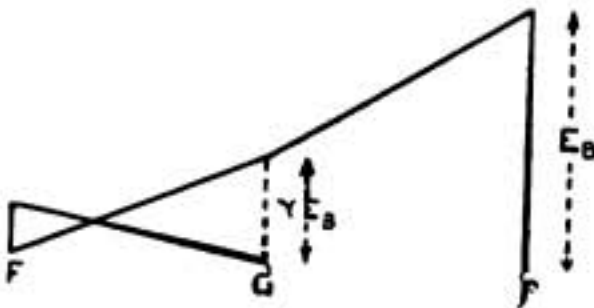

Fig. 9.

Obviously, since E_s is now diminished by reason of E_C , the force drawing the electrons to G (prior to their coming into the intense field of E_B between G and P) will be lessened, resulting in a corresponding decrease of current through the valve. Further, the flow of current will be completely stopped when the negative value of E_C equals the positive value of γE_B . This leads

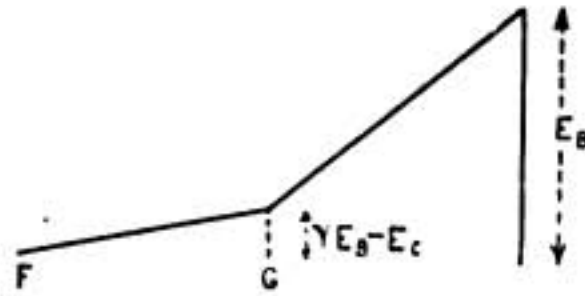

Fig. 9a.

to the statement that when E_C is negative the value of the stray field is

$$E_s = \gamma E_B - E_C.$$

To summarise the preceding remarks we may say—(1) With E_C constant an increase of turns on the grid (*i.e.* when gamma diminishes) results in decrease of current through the valve, and conversely a decrease of the number of turns on G (*i.e.* when gamma increases towards unity) enhances the valve current. (2) With γ constant, making E_C positive increases the plate current, and conversely, making E_C negative decreases the plate current until it is completely stopped, at which point E_C is equal and opposite in sign to γE_B .

Alteration of grid diameter.

While it is not suggested that the following is by any means a full explanation of all the effects of the alteration of the position of the grid relative to the filament and anode, it is believed, however, that it will serve in conveying to the reader's mind the elementary principles involved. It will be seen from remarks that follow, under the heading of operating constants, that as the grid nears the filament the voltage amplification factor will become less, and as a result the current through the valve will increase; but, although this is obvious from the equation referred to, it is proposed to show graphically the effect of change of grid diameter.

Retaining the electric field slope conception, in Fig 10 it has been assumed that γ has some finite value, which results in the stray field equivalent to the height FG . Now let the grid be moved to the positions G_1 and G_2 in turn. In the first case G_1 , the screening effect of the grid will be less

than when at G , in other words the stray field will have increased, and since this value E_s is proportional to the current through the valve, this will now also be greater. Conversely, when the grid occupies the position G_2 , further from the filament, the screening effect will be greater and the resultant thermionic current smaller than when at the position G .

In the above we have assumed that the grid was at zero potential with respect to the filament. Suppose now a negative potential be given to the grid, and call this E_c as indicated in Fig. 10, then the resultant stray fields, relative to the three different positions of the grid, will be readily seen by reference to the diagram, where E_c has been deducted from them. At the position G , the flow of current will be seen to have fallen to zero.

On the other hand if the grid potential is positive but equal in value to E_c , it is easy to see that the dips in the slopes will be raised to the points P , Q , and R , respectively.

From the foregoing the general statement may be made that, as the grid is

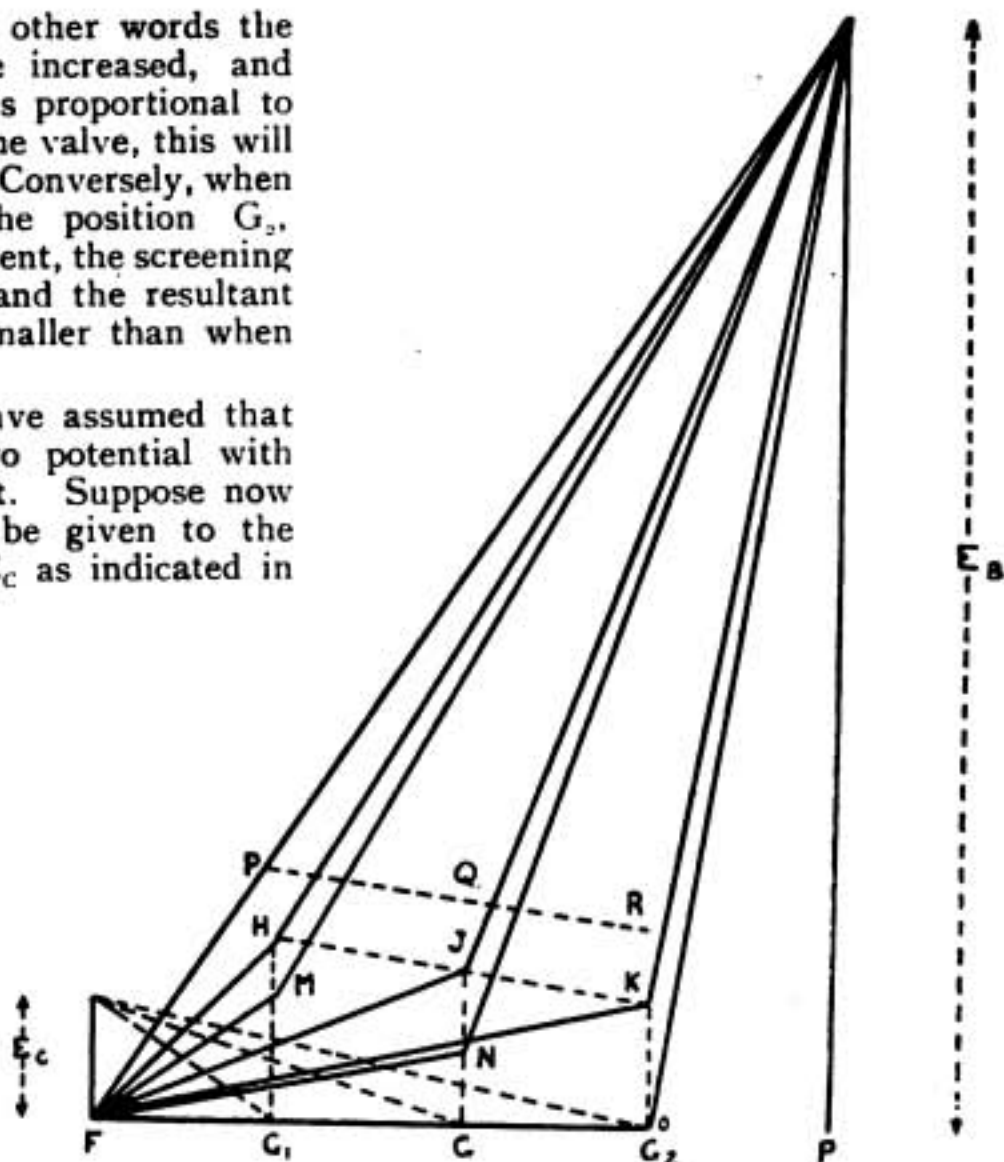

Fig. 10.

brought nearer to the filament, or as its diameter is decreased, the current through the valve will increase, such a result being due to the lessened screening effect of the grid upon the field of E_H . (To be continued.)

Some of the Contents of the February Number

The Training of an R.A.F. Wireless Operator (Illustrated).

How to make a Flexible Socket for Valves (Illustrated).

How to make an efficient Variable Condenser (Illustrated).

Full report of the proceedings of The Wireless Society of London. (Business, Paper by Dr. J. Erskine-Murray, Discussion and Reply.)

Stray Waves

THE AMATEUR POSITION.

T IS a poor heart that never rejoices. Since we last went to press no further developments of the situation have been made public, and the amateur wireless world has settled down to make the best possible use of available facilities. With the exception of the dimensions of the aerial matters are not so bad on the receiving side, and although many of us are inclined to say of our modest stretch of aerial, "A poor thing, but mine own," it must be remembered that much can still be done, especially with well-separated twin wires, whilst the frame aerial provides a fascinating and wide field for experiment.

It gives us pleasure to note the ever-increasing activities of the various wireless clubs and the rapid rate at which these young phœnices are rising from the ashes of 1914. So far we have twelve on record, and we shall be grateful to the Secretaries of any clubs with whom we are not in touch if they will make their existence known to us.

We direct the attention of all whom it may concern or interest to the following extract from the Radio Service Bulletin which issues from Washington:—

"Effective October 1, 1919, all restrictions on amateurs and amateur radio stations are removed. This applies to amateur stations, technical and experimental stations and colleges, and to all other stations, except those used for the purpose of transmitting or receiving commercial traffic of any character, including the business of the owners of the stations."

"The restrictions on stations handling commercial traffic will be removed as soon as the President proclaims that a state of peace exists."

"Before operating transmitting stations it is necessary to take an examination and secure an operator's licence and have on file with the district radio inspector a formal application for station licence. The radio inspector can assign radio call letters when the application is received."

"All amateurs should be familiar with the Radio Laws and Regulations. This publication can be procured from the Superintendent of Documents, Government Printing Office, Washington, D.C. Price, 15 cents."

"All transmitting sets should be inductively coupled. Stations having what is known as plain aerial, or the spark gap directly in the antenna circuit, will not be licensed where they do not comply with regulations 3 and 4 of the Act of August 13, 1912."

"The list of Radio Stations of the United States, edition of June 15, 1919, does not contain amateur stations. This publication can be procured from the Superintendent of Documents, Government Printing Office, Washington, D.C. Price, 10 cents."

WIRELESS TELEPHONY AND FOREST FIRES.

The United States Forest Service is now employing wireless telephone apparatus in connection with the reporting of forest fires. A case recently arose when such a fire was reported by wireless telephony from a portable instrument from a mountain top 11,125 ft. above sea level. These instruments

have a range of several miles, and it is proposed that they shall derive their power from small wind-motors to make use of the powerful winds which are always present at such high altitudes.

THE WIRELESS STATION AT EILVESE (HANOVER).

A few details of the apparatus installed at this high-power station are given by A. S. M. Sorenson in the *Elektrotechnische Zeitschrift*. The antenna system is of the umbrella type, the central tower being 250 metres high with six 122-metre tubular masts surrounding it. The plant includes two Goldschmidt high-frequency machines which have given very good results. These machines can be operated in parallel if necessary, but it has been found that satisfactory communication with America can be effected using only one of them. L. V. Austin has measured the strength of signals received in America from Eilvese and from Nauen and obtained the following values respectively 21.6×10 amp. and 14.4×10 .

THE MAINTENANCE OF MECHANICAL OSCILLATIONS BY MEANS OF THE THREE-ELECTRODE VALVE.

In a recent paper presented to the French Academy of Sciences, Messrs. H. Abraham and E. Bloch describe methods of using an ordinary three-electrode valve for sustaining the oscillations of a pendulum. The pendulum is fitted with a magnet influencing two coils, one connected to the grid circuit and the other to the anode circuit of the valve. By joining the windings in the proper direction the amplified currents from the valve may be caused to sustain the movement of the pendulum. If a multi-stage amplifier is used the effects can be increased and the pendulum will then start up from rest.

A similar arrangement may be used

to sustain the tuning fork in vibration. It is particularly suitable for forks of high-frequency (1,000 or more per second) for which difficulties are sometimes experienced with the ordinary make and break contact.

Similar arrangements for tuning forks were also recently described by Dr. W. H. Eccles and F. W. Jordan.

THE DESIGN OF MULTI-STAGE AMPLIFIERS USING THREE-ELECTRODE THERMIONIC VALVES.

A paper on the above subject was read by Professor C. L. Fortescue at a Wireless Sectional Meeting of the Institution of Electrical Engineers on Wednesday, November 19th. The methods given in this paper were developed in the course of working out the design of valve amplifiers for naval wireless purposes. It deals with the simple case of a single valve used as a resistance amplifier, and by ascertaining that the working parts of the characteristic curves may be taken as straight lines the equations for the voltage amplification are developed. After considering various ways in which more than one valve may be connected in cascade to form a multi-valve amplifier the author dealt with the reaction effect due to reaction coupling between various valves.

The paper was largely devoted to the derivation of the mathematical expressions for the amplification factors of the various valve arrangements, and a general expression was also given for a number of valves in cascade.

The paper was followed by a discussion which was opened by Professor Howe and continued by Mr. L. B. Turner, Mr. Catterson-Smith, Captain H. J. Round, Major J. Erskine-Murray, Captain Slee, Mr. B. S. Gossling, Mr. J. Scott-Taggart, and Dr. W. H. Eccles.

Digest of Wireless Literature

SIMULTANEOUS SENDING AND RECEIVING.

By E. F. W. ALEXANDERSON.

PROCEEDINGS OF THE INSTITUTE OF RADIO-ENGINEERS, AUGUST, 1919.

MOST workers in radiotelephony must have observed that the interchange of ideas is not satisfactory if it is necessary to manipulate a switch of some kind to change the set from the sending to the receiving arrangement. It thus can be said that one of the most important problems from the point of view of making radiotelephony useful to the general public is to devise a simple method of duplex operation whereby the speaker can hear the voice of the other party as is the case in line telephony. Fessenden was the first worker to devise such a scheme, the same aerial being used for simultaneous transmission and reception. The method, however, involves a very high degree of selectivity between the sending and receiving wavelengths and bristles with difficulties when carried out on a practical scale.

The present account deals with attempts to solve the same problem in different ways. The first method that yielded practical results was to use separate sending and receiving antennae located sufficiently far apart so that only an ordinary degree of selectivity was required to enable one to differentiate between the wavelengths of the sending and receiving stations. Each pair of sending and receiving stations were connected by means of telephone wires, and also connected to the local telephone exchange so that any subscriber could use the radio-system. The diagram of connections is shown in Fig. 1. The

subscriber and the sending station are connected together like the ordinary subscribers to a line telephone exchange. It will be seen from the scheme of connections that any signals received on the receiving antenna will be transformed into a current flowing in the closed circuit between the subscriber's instrument and the instrument in the sending station. Thus the message will be transmitted in the same way as the current carrying the voice of the local subscriber. Thus both sides of a conversation are transmitted by each sending station and a third party can hear both sides of the conversation by tuning in alternately on the two wavelengths.

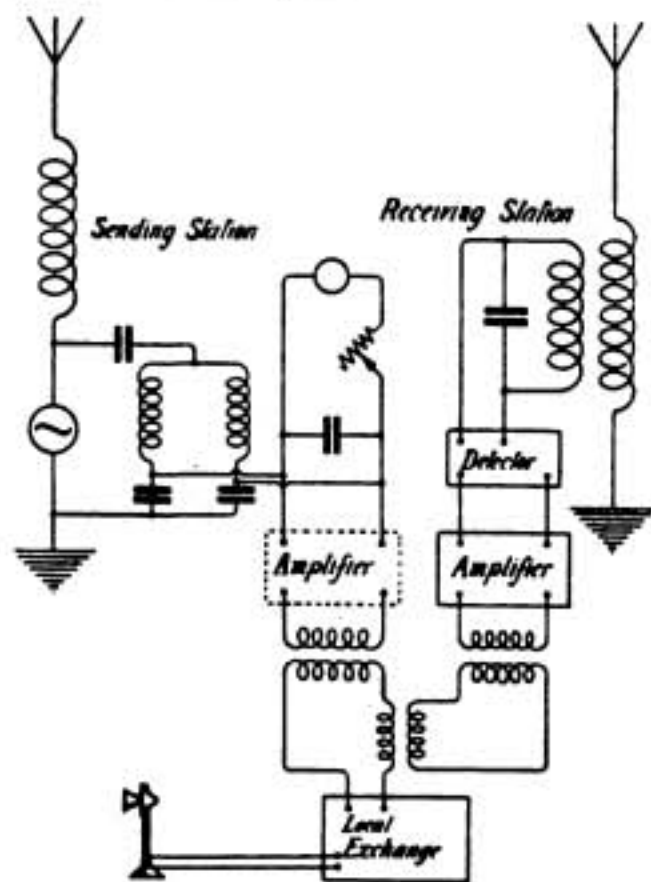

Fig. 1.

The above method will probably prove the most practicable for communication over long distances between subscribers of telephone exchanges. There are, however, cases in which connection with a local exchange is not practicable. For example in the cases of emergency communication between sub-stations of electric power systems, or in the train radio-telegraphic service, it is essential that the sending and receiving equipment should be a unit controlled by the same operator. The most desirable arrangement under these conditions would, of course, be some circuit analogous to that of Fessenden. As a result of experiments on this subject the final solution was an arrangement with a neutralized receiving antenna mounted on the same mast as the sending antenna. This method will now be described in greater detail.

In the general case of two aerials mounted on the same mast the radiation from one to the other is so strong that

the effect of the sending set on the receiver is almost of the same order of magnitude as the effect with the aerials joined together. Two methods of neutralizing the effect of the sending aerial on a receiving aerial fixed on the same masts have been developed. These may be termed the methods of inductive neutralization and capacity neutralization respectively.

The connections used in the method of inductive neutralization are shown in Fig. 2.

Here *S*, the sending antenna, is mounted on the same masts as *R* the receiving antenna, two separate leads-in being used. The oscillations in the sending antenna affect the receiving antenna in two ways, (a) by direct exposure from aerial to aerial, and (b) by direct and inductive connection by means of the neutralization transformer *T*. This transformer *T* is so designed that these two effects are approximately equal in

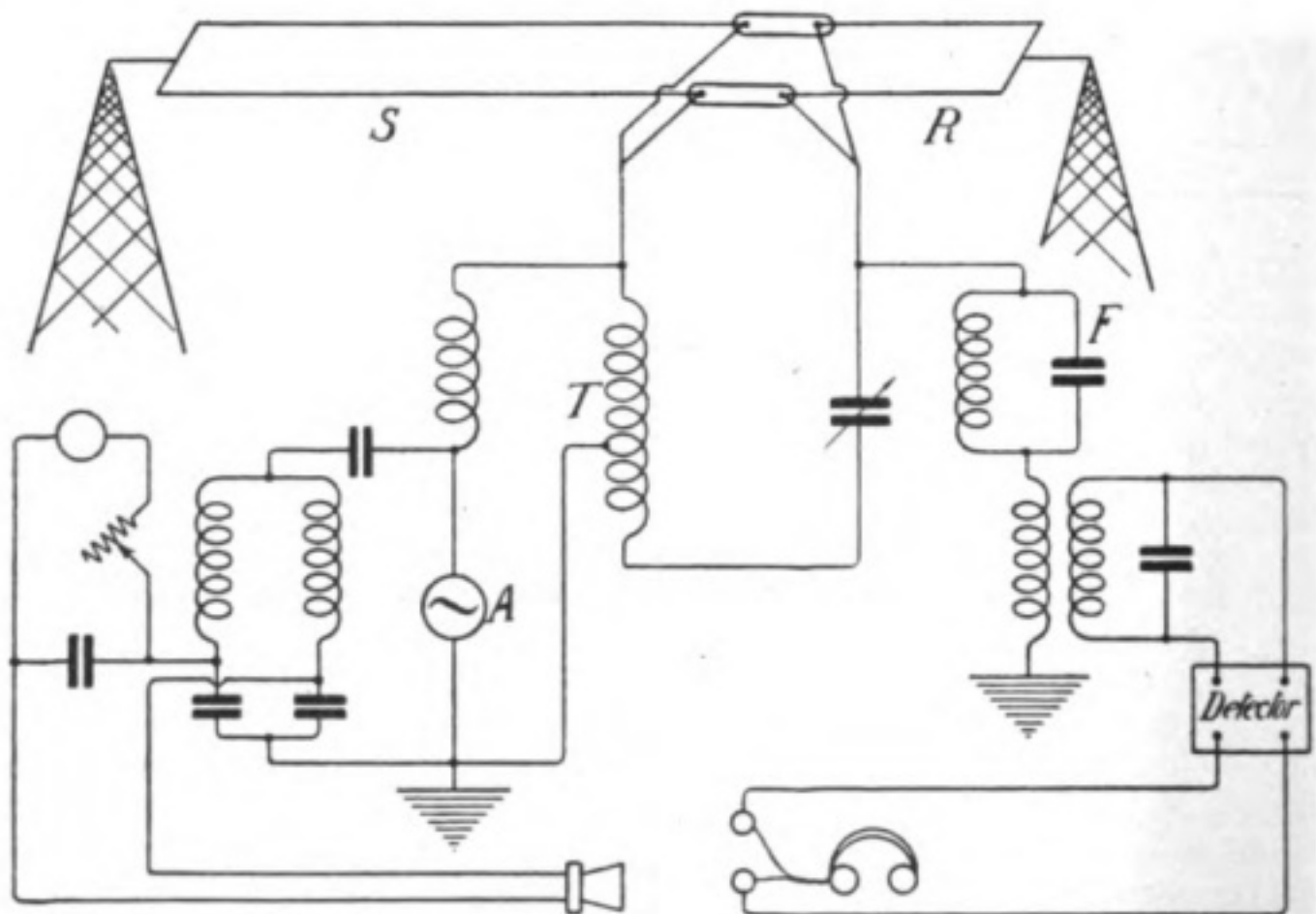

Fig. 2.

magnitude and 180° out of phase, in which case they tend to neutralize each other. In most cases this adjustment can be made so that only a slight residual potential effect is left in the receiving antenna. This can usually be eliminated by the frequency trap F .

The system for capacity neutralization is shown in Fig. 3a.

The receiving antenna R is connected through a shielded primary loading coil T to a condenser C_3 and thus to earth. This loading coil is coupled aperiodically to the secondary of a receiving set (not shown in diagram) of any ordinary type. By means of the condensers C_1 , C_2 and C_3 the effect of the sending antenna on the coil T can be reduced to zero. The theory of this arrangement can perhaps best be understood by consideration of Fig. 3b which represents the connections of Fig. 3a re-drawn in the form of an ordinary Wheatstone's bridge. Here the letters have the same significance as in Fig. 3a, and C_4 represents the capacity between the receiving antenna and earth. If the potential differences are so arranged that B and D are at the same po-

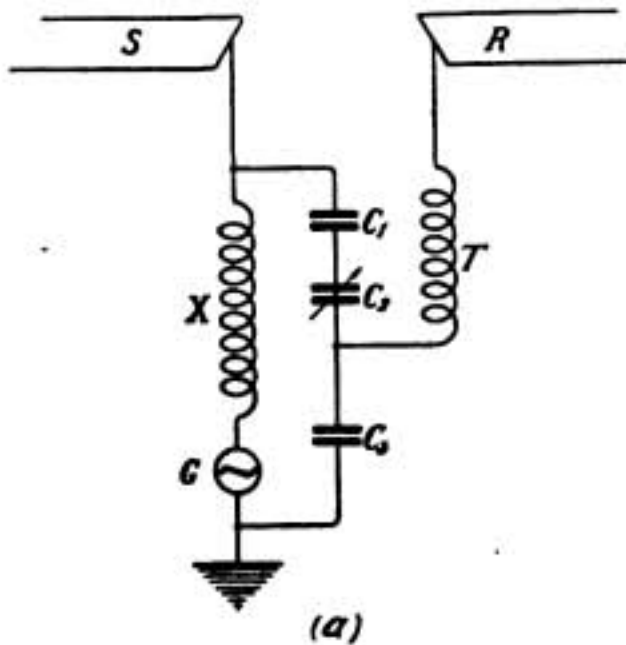

Fig. 3 (a).

tential (as in the case where a "balance" has been obtained in an ordinary Wheatstone's bridge) no effect will be produced

in T and thus no effect in the receiver. This result can be brought about by suitable adjustment of the condenser C_2 .

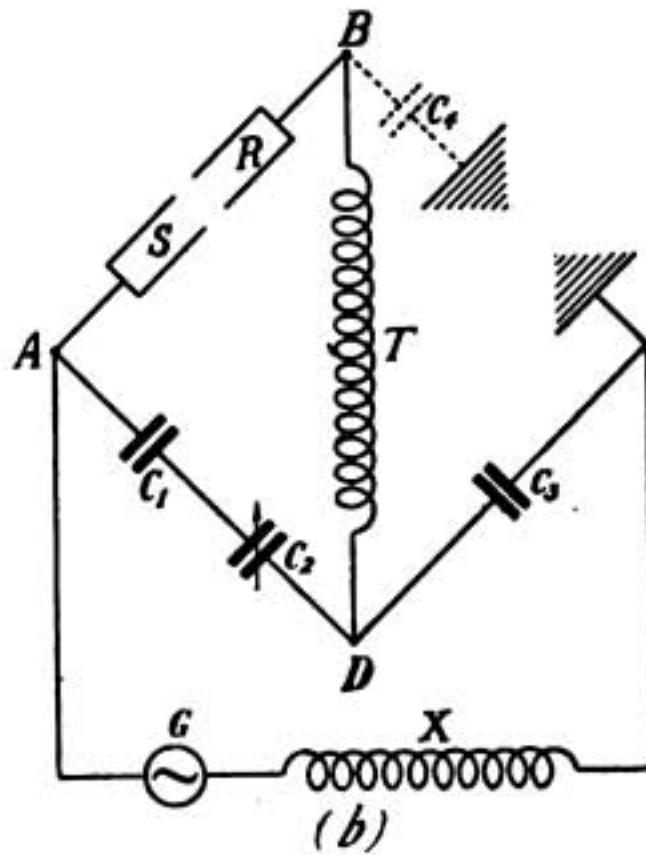

Fig. 3 (b).

As an example of the effectiveness of these methods the following details may be cited. In some tests made at Schenectady the receiving antenna consists of five wires mounted as an umbrella around the main mast while the sending antenna consists of two wires extending from this mast to another building. The mutual capacity of the two antennæ is such that 10,000 volts in the sending antenna produce 500 volts in the receiving antenna when it is disconnected. It is obvious that an oscillating voltage of this amount in the receiving antenna would preclude the use of the ordinary methods of reception. Yet the neutralization system has enabled the receiving antenna to be used for the reception of signals from the Pacific coast (2,500 miles distant) without any appreciable interference from the main sending antenna when the latter was radiating 20 ampères at 10,000 volts.

How Aeroplanes are Navigated by Wireless

By R. KEEN, B.Eng.

Part II.

WHILST the principles governing the navigation of aeroplanes by wireless are fairly simple by comparison with astronomical navigation, the achievement of satisfactory and accurate results has presented many problems since the Wireless Direction Finder was first put to this use.

Probably the best method of gaining an insight into the practical side of wireless navigation will be to trace in outline the installation of a D.F. in a standard type of aeroplane, indicating some of the more important troubles which are experienced, how they are avoided and finally the rather striking results which may be confidently expected with modern apparatus.

Suppose the fuselage of a large passenger-carrying machine to take the form shown in Fig. 1. The D.F. apparatus is located right forward in the main cabin, so as to be out of the way of the passengers and the front seat is occupied by the operator who may also be the navigator. He will be in telephonic communication with the pilot, and both navigator and pilot have magnetic compasses. It will frequently be necessary for the navigator to take simultaneous readings of the magnetic and wireless compasses for reasons explained in Part I* of this article and the pilot needs a magnetic compass in order to make the course which is given him by the naviga-

tor. Having decided on the disposition of the apparatus, the next thing to be settled is the arrangement of the two frame aerials which, it will be remembered, have to be at right angles to one another. The obvious method is to run one of these aerials round the wings and the other round the fuselage; this is found to be quite satisfactory. Small frames are sometimes used in the interior of the machine in place of the large fixed aerials and separate D.F. instrument, but this article deals only with the latter arrangement. The receiving power of small frames is less, necessitating higher amplification of signals and also the larger frame is more directive.

The fixing of the wing aerial does not offer any great difficulty. Starting from a leading-in tube under the fuselage, rubber insulated wire is "doped" on to the fabric under the lower plane, and taken along to a point under the end strut. It is then taken through the lower plane, up the back of the strut and along under the top plane to the corresponding strut at the end of the other wing and so by a similar route, back to the leading-in tube. The fuselage aerial offers a little more trouble. In order to make this frame of the same area as the wing aerial it is necessary to erect short masts at either end of the fuselage, adjusting their height until the receiving power of the two frames is approximately the same. A foremast is also essential in order to allow the aerial to clear the pilot and front passengers. Fig. 1.

* WIRELESS WORLD, October, 1919, p. 389.

HOW AEROPLANES ARE NAVIGATED BY WIRELESS.

shows how these masts may be fitted, care being taken that the after one does not project far enough through the fuselage to foul the tail skid or to be broken in a bumpy landing. Bare wire may be used for this aerial and must be strong enough to ensure that there is no danger of it breaking and fouling the propellers. It is carried up the masts, under the fuselage and over the top plane through porcelain insulators, supported in metal clips, and is led in with rubber covered wires along with the other aerial. The photograph on page 414 of the October issue of the *WIRELESS WORLD* shows an aeroplane fitted with D.F. apparatus, the masts and the in-

strument in Part 1, the two field coils (each wound in two sections) and the cylindrical tight coupled search coil can easily be traced. With the possible exception of the D.F. itself, the whole of this gear is enclosed in a metal screening case, supported from the roof, floor, and bulkhead by means of shock absorbers. Each piece of apparatus is in a separate compartment in the case in order to provide complete electrical screening. The pairs of aerial leads from the leading-in tube are respectively twisted together and all precautions taken to avoid mutual induction between the aerials. It will be noted at once that the aerial system is not sym-

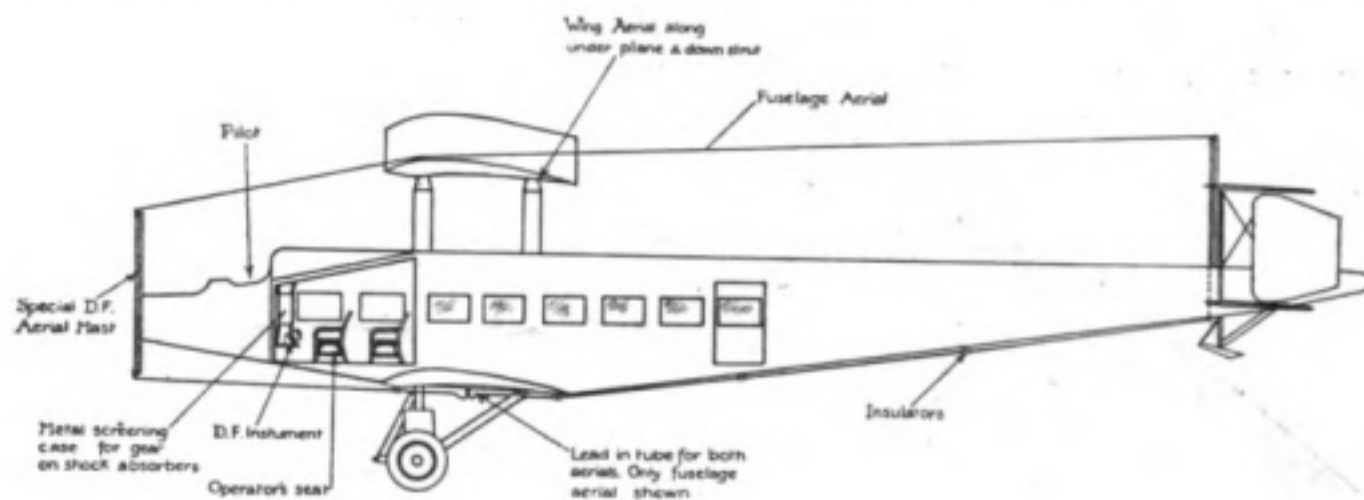

Fig. 1.

ulators under the fuselage being well illustrated.

The apparatus to be installed consists essentially of the direction-finding instrument, the valve amplifier with high and low voltage batteries, a screened transformer, and also apparatus for tuning the receiving circuits and aerials. A specially simplified system is in use on aircraft whereby only one adjustment is necessary when changing wave, the aerials and receiving circuits being simultaneously tuned to the required wave-length. Fig. 2 shows a photograph of one of the latest forms of D.F. instrument removed from its case, and by comparison with the diagrama-

metrical about the line of intersection of the planes of the two frames, but so long as the two frames are exactly at right angles this is not found to be of any great importance. If in spite of every care, a certain amount of mutual induction is found to exist between the aerials, this can be corrected by disposing the aerial leads from the leading-in tube to the apparatus, so that an equivalent amount of mutual induction exists in the reverse direction, the total effect being nil.

The set is now ready for the reception of signals. On tuning in to a long wave, with the aeroplane standing on an aerodrome near London, the signals

from Clifden or Nauen should be painfully loud and audible at a considerable distance from the telephone receivers. This is always provided, of course, that the search coil of the D.F. is swung round to the position of maximum strength of signals from the station in question. At right angles to this direction, the search coil will receive no signals and the pointer of the D.F. can be adjusted so that at this silent position, it indicates the direction of the station, the bearing of which has been previously obtained either by calculation or from a Gnomonic Chart as explained in Part 1. Although the D.F. is now in operation, certain corrections must be made before accuracy can be obtained. Suppose that whilst signals are being obtained from a distant station, the direc-

tion of the station is noted and the whole aeroplane is then swung through a known angle. It will quite probably be found that on taking the direction of the station again the difference in reading on the D.F. is NOT the same as the angle through which the plane was turned. This is due to the metal parts of the engines, stays, etc., receiving and re-radiating the signals and thereby influencing the direction finder. By a fairly simple process of introducing choking coils and other devices, this and also any difference remaining in the receiving power of the two aerials may be allowed for and accurate reading obtained all round the scale. The operation coincides with the compass trials of a new ship in which case corrections have to be made for the effect upon the

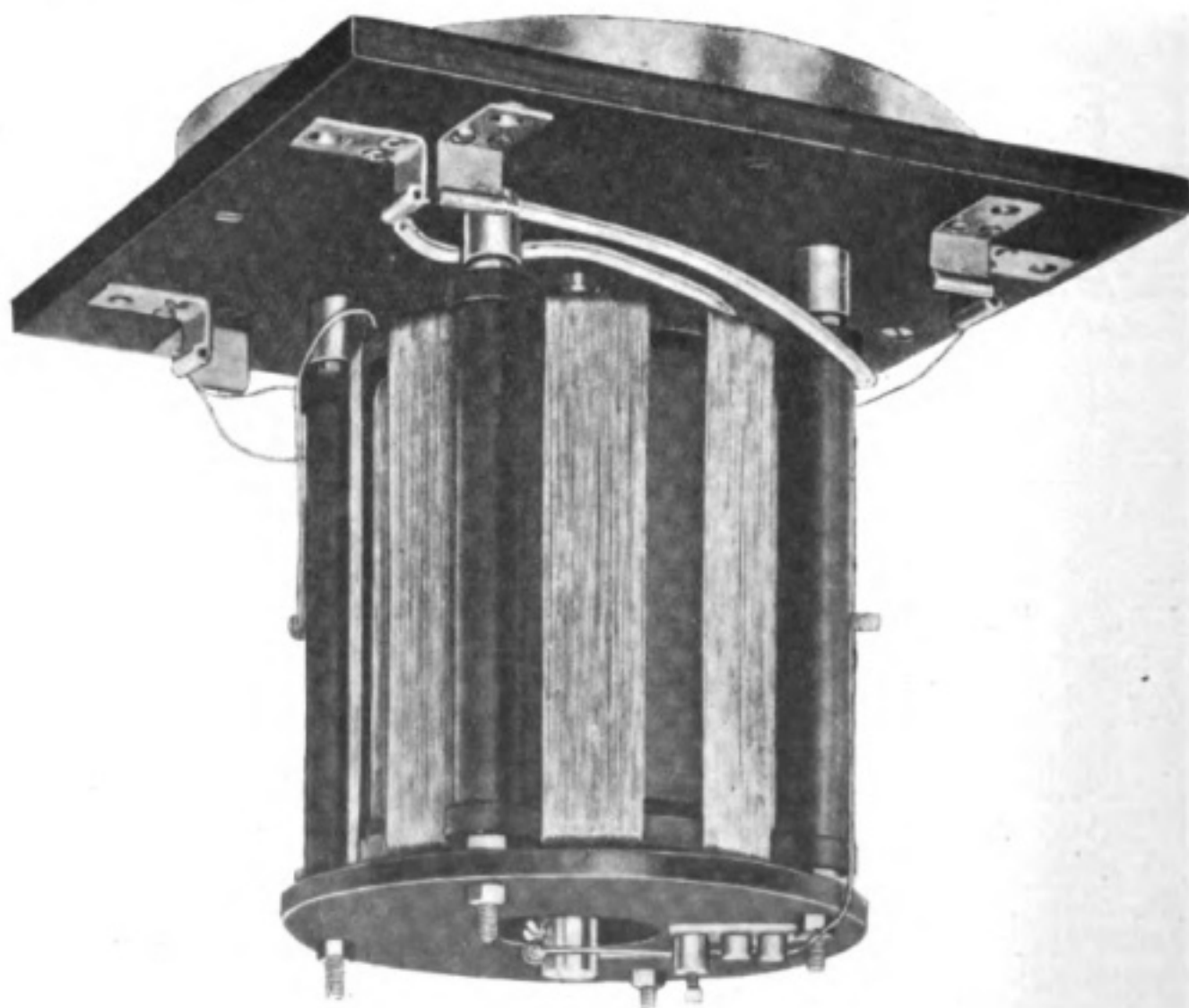

Fig. 2.

HOW AEROPLANES ARE NAVIGATED BY WIRELESS.

magnetic compass of the permanent and temporary magnetism of the hull of the ship. It should be clearly understood that in the case of the D.F. installation here described, namely, with large fixed frame aerials, the operation of correcting the wireless compass forms an exact parallel to that of correcting a ship's compass in that the corrections, once being made, are permanent; the instrument giving accurate readings direct from the scale. In the case of a D.F. using the small rotating frame, the position of which relative to the machine, is constantly changing, a chart of corrections is supplied and it is necessary to consult this and obtain a correction factor each time a reading is taken.

All is now ready for a trial engine run and the serious difficulties at once make themselves apparent. Immediately on starting the engines, a deafening roar is heard in the telephones completely drowning the strongest signals, and this continues without intermission until the engines are shut down. This noise is the induction from the ignition circuits and magnetos of the engines. On large aeroplanes having four engines, each with twelve cylinders, and making some 1,500 revolutions per minute, there will be 48 spark plugs producing 36,000 sparks per minute. To each of these plugs is attached a considerable length of high tension lead which oscillates as a plain aerial each time a spark takes place. Taking into account the fact that a machine similar to that shown in the sketch and fitted with standard D.F. and receiving gear is able, when standing on the ground in England, to receive readable signals from American stations, the reader will readily appreciate the difficulties which arise on attempting to cut out the jamming from what practically amounts to 48 plain aerials all sparking **INSIDE THE FRAME AERIALS.**

The first and most obvious precaution

is to put a metallic screen round all magneto leads and controls and connect these screens to the metal framework of the aeroplane and engines. The lighting leads and also the leads to auxiliary electrical machinery have currents induced in them by the magnetos and also have to be screened, and all the metal parts of the fuselage and wings must be bonded together and "earthed" on to the engines. A large amount of ingenuity has been shown in the various methods which have been evolved for eliminating magneto noise by screening and also by specially designed wireless apparatus and ignition systems, and by an intelligent use of them the problem has been solved. The external noise from the engine exhausts is another troublesome factor, but if the telephone ear pieces are sewn into the operator's helmet and kept well pressed to the ears, this noise can, to a large extent, be cut out.

The valve amplifier has played a large part in making D.F. work on aeroplanes a practical possibility, and the person who finds himself in an aeroplane to-day—more particularly if he be a pre-war wireless enthusiast—will find it difficult to believe that with the aerials available, it is comparatively easy to take directions of transmitting stations at distances of several hundred miles in the midst of a noise which renders conversation very difficult and frequently impossible.

The installation of a small two-seater machine offers new difficulties. In this case the pilot himself should be able to operate the D.F. and what is more, it must not add more than is absolutely necessary to the array of apparatus which he already has before him. This is accomplished by the use of a miniature form of D.F. instrument and circuit tuning device, all the more bulky apparatus being located in the fuselage of the machine with remote controls for the amplifier. If the machine is fitted with

a wireless telephone set, it is not necessary, in general, to instal a second one for the D.F. as any standard valve amplifier is suitable for the work in connection with both sets.

When flying in a strange district where the bearings obtained by D.F. have to be plotted out carefully on a chart, it would be necessary to have an

observer to do this work, but once the route is well known, the pilot will have little difficulty in recognising the notes of the various stations in range—especially if beacon stations are erected for the purpose—and from constant practice will be able to know to within a remarkable degree of accuracy when he has reached his destination.

NOTES ON THE MEASUREMENT OF WAVELENGTH AND H. F. INDUCTANCE AND CAPACITY.

By B. WILLIAMS, B.Sc.

IN measurements of wavelength of oscillatory circuits either damped or undamped waves may be employed. In the former method the circuit to be measured is excited by means of a buzzer and the wavemeter is adjusted for maximum sound in the telephones. No matter how loose the coupling between the two circuits there is always a doubt as to the exact setting of the wavemeter condenser for resonance. When using continuous waves the circuit to be measured must be made to generate feeble continuous oscillations which, interfering with the oscillations generated by the C.W. wavemeter, produce beats in the telephones of audible frequency. The frequency of this note in the telephones can be varied by altering the wavemeter frequency and is zero when both circuits are in resonance. There is always a slight range on the condenser during which nothing is heard, and therefore the correct setting of the condenser is again in doubt.

It is a well-known fact that if an oscillatory circuit is coupled to a circuit which is *just* generating undamped oscillations, or the coupling between grid and sheath coils is just tighter than required for the oscillating point, the latter will cease to oscillate when the two circuits are in resonance. This is accompanied by an increase in sheath current if there is a grid leak in the generating

circuit, or a decrease in sheath current if there is no grid leak in circuit. This is shown by a milli-ammeter in circuit or by a click in the telephones. Usually in practice there are two points on the wavemeter condenser at which this appears, corresponding to the two apparent wavelengths of the oscillatory circuit due to the mutual induction between the two circuits. These points on the condenser are the nearer together the looser the coupling between the circuits, and therefore by sufficiently loosening the coupling the two clicks will coincide. Alternatively the real setting of the wavemeter condenser can be found by taking the mean of the readings of the condenser when the clicks are heard. As the clicks are perfectly sharp and definite there can be no personal error in reading the condenser.

This method does not require the circuit under measurement to be fitted up to generate either damped or undamped waves and it is certainly more accurate than either of the usual methods.

The setting of the wavemeter to *just* generate continuous oscillations may be effected by the variation of reaction coupling or by a finely variable rheostat in the filament circuit. For the measurement of H.F. values of inductance and capacity it is only necessary to make either the capacity or inductance part of the oscillatory circuit under test a standard.

An Experimental Station

By E. LUDWIG.

(We publish the following article as it describes a neat and ingenious amateur experimental station, and may be suggestive to other private workers. Most amateurs, no doubt, will wish to use valves for reception and the necessary adaptation of the circuits here shown should not present much difficulty. British amateurs must use an aerial slightly smaller than the one described.)

MANY amateurs do not carefully enough protect their stations from lightning. Even the smallest discharge may ruin at least the detector. The connections shown in Fig. 1 give a very efficient protection of the whole receiving station and of the detector itself.

See Fig. 2.—*The aerial \mathcal{A}* (Inverted L type) consists of 6 ten-metre lengths of No. 14 S.W.G. hard drawn copper wire kept 50 cm. apart by wooden hoops 1 m. in diameter, suspended from a mast on the roof of a building to another 10 m. high. From the hoop on the roof 6 downleads are stranded into a cable for about 1 metre before entering the operating room to be connected to the lightning protector. The "earth" is connected in the usual way.

The lightning protector LP consists of two choke coils of about 30 turns of No. 6 (Birmingham W.G.) on a porcelain core of 3" diameter with lever switches as illustrated. When using the station, open 2, close 1 and 3; if not using station, close 2 and open 1 and 3. Choke coils are more advantageous than insulators would be (Fig. 1).

The change-over switch (4) leads to the instruments. On the two-way switch (5) telephone fuses are mounted. This switch brings into circuit two jiggers: $L_1P_1S_1$ and P_2S_2 ; L_1 is an in-

ductance (loading coil) made of a cardboard tube 4" long, $3\frac{1}{4}$ " diameter, on which 100 turns of No. 20 S.C.C. S.W.G. are wound and tappings taken to a multiple-way switch on the box in which the inductance is mounted. P_1S_1 is a loose coupler as described by Mr. J. F. L. Corkett, i.e., a wooden square former for both primary and secondary windings.

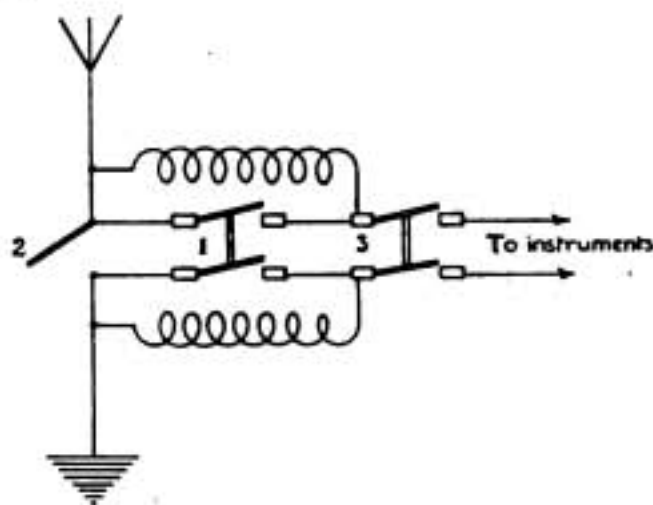

Fig. 1.

P_2S_2 is a stationary coupler which does the rough tuning. The secondary S_2 consists of No. 28 S.C.C. S.W.G. copper wire on a cardboard tube 4" diameter, 8" long, tappings being taken through holes in the tube to the multiple-way switch on box. Over the secondary a piece of insulating cloth is fixed by means of shellac varnish, and over this the primary is wound (No. 22 D.C.C. S.W.G.). Tappings are taken to switches

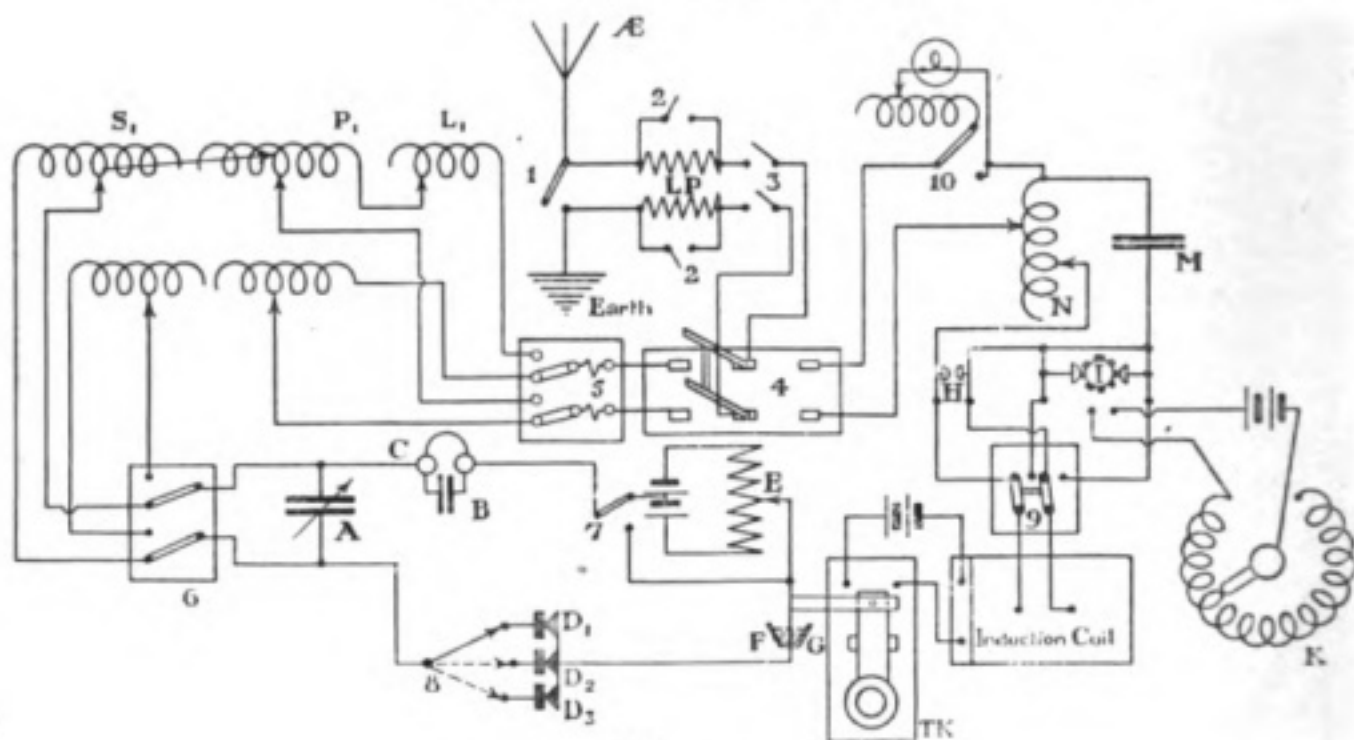

Fig. 2.

on the same box in which this coupler is mounted.

Both secondary coils S_1 and S_2 are connected to switch (6) mounted on condenser below.

The telephones (c) have a resistance of 3,500 ohms. The blocking condenser B has 3 capacities: .001, .002, .003 microfarad. The switch (7) puts into circuit a potentiometer E for use with carborundum detector D_1 . A crystal cup holds a carefully-selected piece of the crystal by means of an alloy, the melting point of which (140°F.) does not affect the crystal. The alloy is made by fusing together 4 parts of Bismuth, 1 of Cadmium, 2 of Lead, 1 of Tin. The crystal presses against a steel surface. Switch (8) allows the use of one of the 3 detectors. D_2 is a zincite-tellurium type (no potentiometer); D_3 is Molybdenite, very robust and reliable, but only for short range work or strong signals. F is a mercury cup (Figs. 2 and 3) which opens the detector circuit every time the transmitting key is pressed down, regardless of the position of switch (4). It saves the detectors from fusing or burning out. A

piece of ebonite is screwed to the end of the key at right angles to it. It carries a connection from detector circuit with an electrode in contact with the mercury; this electrode should be adjustable, of course. This completes the receiving circuit.

Switches 5 and 6 can be converted into a single rotary as shown in Fig. 4. This is an ebonite disc with brass segments A (shaded) and thin brass ribbons to terminals B. 1, 2, 3, 4, 5, 6, 7, 8, are brass spring contacts which end at terminals B. A lever H brings in circuit L_1 , P_1 , S_1 , at position 1, and P_2 , S_2 at 2.

THE VARIABLE CONDENSER A.

This can be made very easily by coating two photographic films (from which the sensitive gelatine has been removed by means of hot water) with tinfoil to $\frac{1}{2}$ " from the edges. These coated films are wound on their original spools and fixed to them by one end. Two ebonite discs, 2" in diam., are centred and a brass bolt passed through each of their centres and held in position by a small nut on either side. Ebonite rods are fixed in the recesses cut in the

AN EXPERIMENTAL STATION.

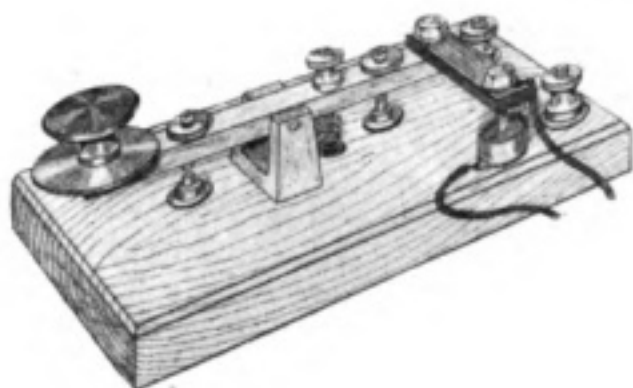

Fig. 3.

discs and form a cylinder which will not be affected very much by expansion from temperature. To one of these rods the loose end of one film is fixed and electrically connected to one of the brass bolts. The other film is connected to the other bolt and fixed to the next ebonite rod. The spring bearings rubbing against the nuts will ensure a good contact, and if these springs are mounted on ebonite and connected to terminals the condenser will be complete in its principle by rotating the ebonite cylinder by the handle at one end. (See Fig. 5.)

Four pieces of brass will be the bearings of four brass screws driven through them into the store-spools. A spring on each spool should store the films as soon as the handle is turned back. The pressure of the spring bearings should be sufficient to overcome the action of the springs.

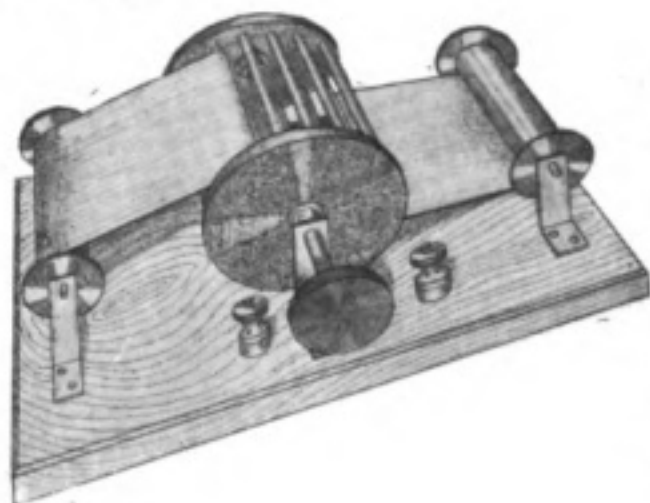

Fig. 5.

If the experimenter wants to calibrate his instrument, he can do it by the Bridge or Wavemeter method. A circular scale can be put round the handle and for observing the number of rotations a cam can be soldered to the axis for moving a toothed ebonite disc, one tooth

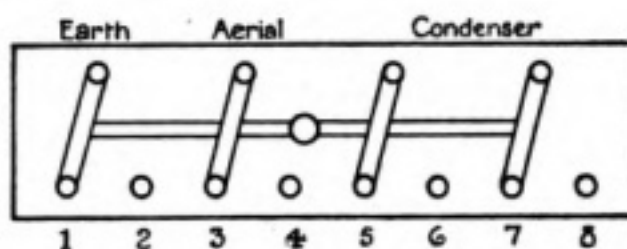
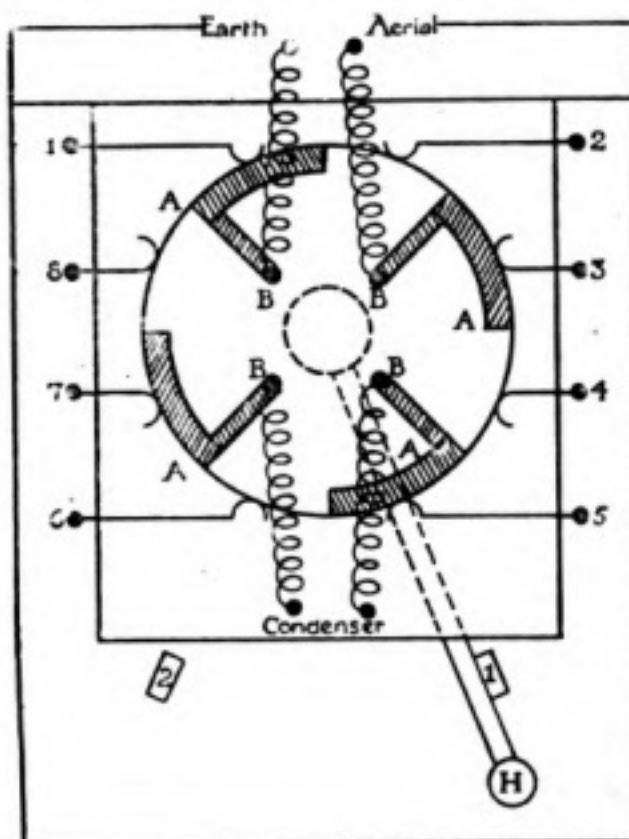

Fig. 4.

for every revolution. A pointer fixed to the axis passing through the edge of the box will indicate the number of turns. It is understood that the films are fixed to the cylinders by their celluloid side. The whole is mounted on a box and if the rotary switch is not used, switch 6 should be mounted on top of the condenser and the terminals on the base.

The transmitting station is quite simple; its range is about 5 km. The induction coil gives a 1.5 cm. spark and is

connected by a 2-way switch to a fixed or rotary spark gap. The condenser consists of 35 sheets of tinfoil $3\frac{1}{2}'' \times 2\frac{1}{2}''$ interleaved with photographic quarter-plates $3\frac{1}{4}'' \times 4\frac{1}{4}''$. The whole is kept together by insulating tape and is bathed in paraffin wax. It is then put in an ordinary wooden box fitted with terminals. This is then fixed into a box containing the battery (storage) for motor of spark gap, its rheostat on one side, switch 9 in front of spark gaps on top, and terminals on base.

The Helix (I used it as a standard) has its heads 7'' apart and the wire used is No. 6 Birm. G., seven complete turns $\frac{3}{4}''$ apart. Diameter of each turn is 10''. The total inductance is about 14 mhys. Finally let us consider the tuning lamp (ordinary flashlight lamp 3.5 volts). The inductance consists of 8 ft. of bare 16 S.W.G. copper wire on a grooved

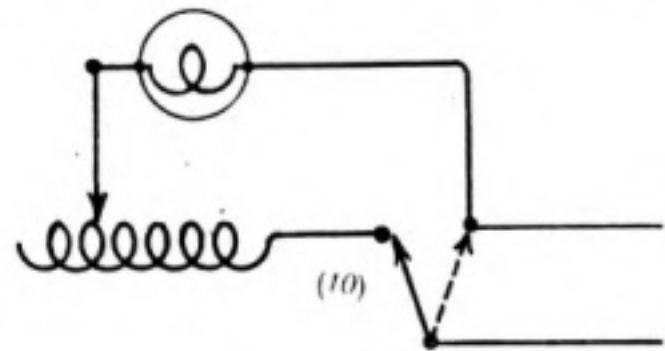
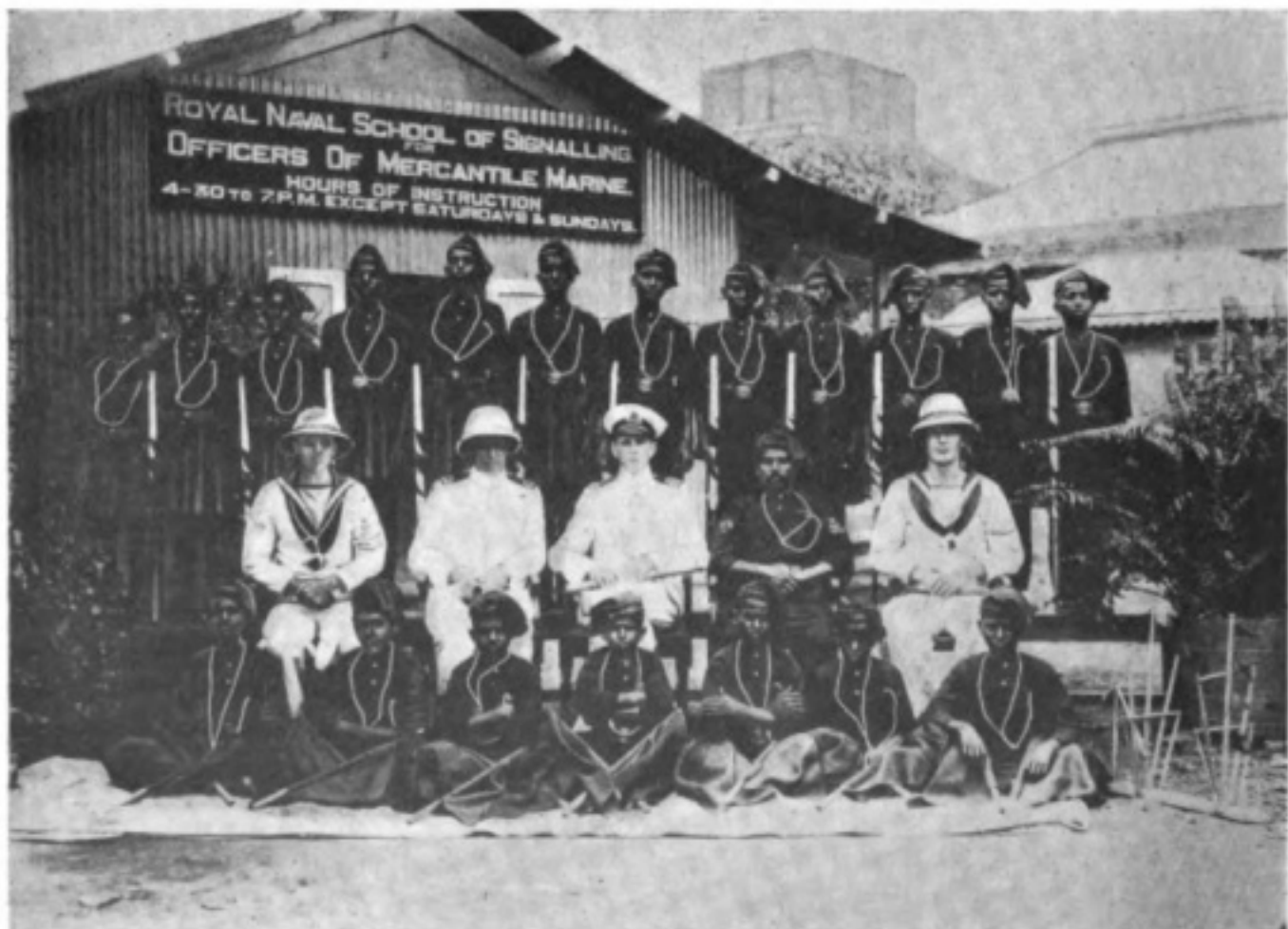

Fig. 6.

wooden former soaked in wax. One end of the wire is free, the other connected to terminal on baseboard. Another terminal is connected to one of the lamp contacts, the other being connected to a pivoted brass arm the extreme end of which may be moved over the inductance. The switch 10 cuts it out (Figs. 2 and 6).

A condenser for shortening the wavelength can be put in series between the tuning lamp and switch (4). (Fig. 2).



A group of Instructors and Pupils at the New School for Wireless and Signalling at Bombay.

Notes of the Month

NEW COMPANIES.

A COMPANY under the title of the Marconi Scientific Instrument Co., Ltd., was registered on November 1st, 1919, with a capital of £12,000. The main objects of the Company are the manufacture and sale of amateur telegraphic and telephonic apparatus, the manufacture of apparatus under licence to be granted by the Marconi's Wireless Telegraph Co., Ltd., and the repair and bringing up-to-date of all obsolete apparatus. The first Directors are Messrs. Henry W. Allen, W. W. Bradfield, C. Mitchell, W. W. Drury (Managing), Charles B. Ward (and Secretary). The registered office and works are situated at 21-25, St. Anne's Court, Dean Street, W.C.

• • •

The formation of the Marconi Osram Valve Co., Ltd., was reported in these columns in our last issue. We since learn that the first Directors are Messrs. Henry W. Allen and Christopher Wilson. The Secretary is Mr. H. W. Corby and the registered office and works are situated at Osram Works, Brook Green, Hammersmith, W.

• • •

Further particulars of the Chinese National Wireless Company are now available. The Board of Directors is as follows: Vice-Admiral Chen Ngen-Tao, Chief of the Executive Board, Ministry of the Navy, Peking; Lt.-Col. Ting Ching, who was until recently Director-General of Military Operations, Ministry of War, Peking; Lin Chih-Hsin, a Chief du Bureau of the Ministry of Communications, Peking;

Mr. Godfrey C. Isaacs, Managing Director of Marconi's Wireless Telegraph Co., Ltd., London; Mr. T. A. Barson, Chairman of the Peking Syndicate, and Mr. A. H. Ginman a Marconi representative in China. The Company is to utilise materials produced in China in preference to imported materials in all cases in which such materials are neither lower in quality nor higher in price than the imported materials. Chinese will be employed on the personnel as far as possible, and when the Company's Works are in operation the technical education of students will be undertaken by the Company.

• • •

A new Dutch wireless company, called the Nederlandsche Telegraaf Maatschappij "Radio-Holland" has been formed with a capital of one million florins. Under an agreement with the S.A.I.T. sans fil, which dates from April 1st, 1919, the "Radio-Holland" acquires the rights of wireless installations on Dutch mercantile vessels (Netherlands and Dutch colonies) and the contracts relating thereto.

• • •

WIRELESS TIME SIGNALS FOR SHIPS.

The Admiralty Notice to Mariners (No. 1993 of 1919), cancelling No. 1264 of 1919) gives a complete list of all time signals transmitted by wireless stations throughout the world.

It foreshadows a universal standardisation of signals and a regularisation of the times at which the Stations send out both these and the Wireless weather bulletins.

DR. J. A. FLEMING'S LECTURES ON VALVES.

On November, 19th, at University College, Prof. Fleming continued his lectures on the Three-Electrode Valve, dealing, in his usual able manner, with the valve as an H.F. generator.

During his lecture he used for demonstration purposes the original valves used at Ballybunion Station for transatlantic experimental work.

His fifth lecture, on November 26th, dealt with the valve and its use in wireless telegraphy for C.W. and Spark transmission. He showed several standard circuits for audio or radio-frequency amplification and also a circuit for the combination of the two. Lord Rayleigh's "whistle experiment" to determine the smallest amount of power required to produce audible signals, was described in detail as a basis to prove how remarkably inefficient the present day magnet telephones are; on an average only $\frac{1}{700}$ th of the power supplied to the receiving aerial reappears in the form of sound.

On Wednesday, December 3rd, Professor Fleming concluded his series of lectures by first of all giving a brief summary of the valve, from its discovery to its present day adaptations. He gave a detailed description of how to arrive at the internal resistance and the characteristic curve of a valve—also a brief description of how the P.O. is using the three-electrode as a relay adding considerably to the distance over which speech is being transmitted. To conclude he stated that he had a valve depending on different principles to those of the three-electrode, by means of which he hoped to be able to ring a bell across the Atlantic. The theory of it is complete and the only trouble to overcome is that of manufacture.

THE IMPERIAL WIRELESS CHAIN.

The Cabinet has approved the appointment by the Secretary of the State for the Colonies, as Chairman of the Imperial Communications Committee, of the following Committee to prepare a complete scheme of Imperial Wireless Communications.

In so doing it will deal with the following items:—

1. To consider what high power stations it is desirable on commercial or strategic grounds that the Empire should ultimately possess.
2. To prepare estimates of the capital and annual costs of each station, the life of the plant and buildings as taken for the calculation of depreciation to include an adequate allowance for obsolescence.
3. To examine the probable amount of traffic and revenue which may be expected from each station.
4. To place the stations recommended in their order of urgency.

The members of the Committee are:—

The Rt. Hon. Sir Henry Norman, Bt., M.P. (Chairman),
F. J. Brown, Esq., M.A., B.Sc.,
Rear-Admiral F. L. Field, C.B., C.M.G.,
Sir John Snell, M.I.C.E.,
J. E. Petavel, Esq., B.Sc., F.R.S.,
Dr. W. H. Eccles, M.I.E.E.,
J. Swinburne, Esq., F.R.S., M.I.C.E.,
L. P. Turner, Esq., M.A.,
Brig.-Gen. S. H. Wilson, C.B., C.M.G. (Sec.),
Lt.-Col. C. G. Crawley, R.M., A.M.I.E.E. (Assistant Sec.).

All communications in connection with the Committee should be addressed to the Secretary, 2, Whitehall Gardens, S.W.

NOTES OF THE MONTH.

WIRELESS SERVICE TO SWEDEN.

The Postmaster-General has made arrangements with the Swedish Government for the establishment of a wireless service supplementary to the cable service between Sweden and this country. The rates are the same as by cable, 2½d. per word for ordinary telegrams and 1¼d. per word for Press telegrams.

• • •

LEEDS UNIVERSITY HONOURS ADMIRAL JACKSON.

The honorary degree of Doctor of Science was recently conferred by Leeds University upon Admiral Sir Henry B. Jackson, G.C.B., K.C.V.O., F.R.S.

• • •

LECTURE BY DR. W. H. ECCLES.

At 6 p.m. on Dec. 3rd, at the City and Guilds Technical College, Finsbury, Dr. W. H. Eccles delivered to a packed audience a popular lecture on wireless telegraphy, condensing into the space of one hour a swift, historical sketch of the development of the art, concluding with a simple account of the working of triodes. Mr. A. A. Campbell Swinton occupied the Chair, and in proposing a vote of thanks to the lecturer, interpolated some amusing stories of his own "wireless" experiences.

WIRELESS CLUB NOTES.

THE WIRELESS SOCIETY OF LONDON.

Will all those interested kindly note that the address of the Secretary (Mr. H. Leslie McMichael) is now 32, Quex Road, West Hampstead, N.W. All applications for membership should be sent to this address.

Entrance fee, 10s. 6d. Subscription, One guinea; Country members, 10s 6d.

BURTON WIRELESS CLUB.

At a meeting of this Club on November 19th, Mr. A. J. Selby gave a lecture on Wireless Telegraphy to a large audience. Mr. A. Chapman (Editor of the *Burton Daily Mail*) presided. The Chairman announced that the specifications for the wireless installation it was proposed to erect had been submitted to the Government for approval. The Secretary stated that he had received a letter from the **WIRELESS WORLD** stating that they would be delighted to help the Club collectively and individually, that the magazine was going to devote its pages more to the needs of the amateur and would welcome contributions from the Club. Mr. E. Blake, the Joint Editor of the magazine, was elected a Corresponding Member.

The election of officers being left over from the last meeting, Col. J. Gretton, M.P., C.B.E., was appointed President and Mr. A. Chapman, Vice President. A yearly subscription of 5/- was agreed upon as a membership fee.

In his lecture Mr. Selby traced the history of wireless telegraphy from its earliest stages, concluding with an account of the latest valve detector. He exhibited a model of a wireless set all contained in a wooden box about 8 inches in length, 1½ inches in depth and 4 inches wide. He explained that it was only necessary for the user to make contact with the ground by means of a stick with a steel ferrule and that no aerial was necessary.

Meetings of the Club are held every alternate Wednesday.

Another meeting was held on Wednesday, the 3rd inst., when there was a good attendance, and Mr. R. Chapman lectured on Magnetism and Electricity. The club has a Membership at present of about 25 or 30.

WIRELESS AND EXPERIMENTAL ASSOCIATION.

This go-ahead Club has lost no time in settling down to practical work. At a recent meeting the members were treated to a two hours' discourse by Mr. Greenslade, of the British School of Telegraphy, who gave an exceedingly interesting address of instruction and advice. The Association is now permitted by the P.M.G. to practice reception of signals and the members are energetically erecting the station, each one contributing some material or part.

There has been a subtle air of mingled earnest preoccupation and alert assimilation of new ideas among the members during the past month, betraying the fact that every member was making something for his own station.

Not that the Club station was neglected, for with contributions in kind the aerial has been put up, receiving apparatus furnished and good signals obtained.

The necessary manual assistance was willingly given, being ably directed by Mr. Saunders, the Assistant Manager.

The workshop is rapidly becoming complete in its appointments and many members are more than glad of the assistance which combined effort is able to make available.

The recent gales may have been disastrous to many buildings but so far we have not had bad news of any of our well-constructed aerials being wrecked.

We cannot put F.R.S. after our names but in spite of that we are nearly all Fellows Receiving Signals.

• • •

THE SHEFFIELD AND DISTRICT WIRELESS SOCIETY.

On November 14th Mr. F. E.

Meredith delivered a lecture on the subject of Capacity and Inductance, the meeting being held in the Municipal Officers Club. Mr. H. E. Yerbury (President of the Society) presided over a full attendance of members. Applications for membership should be addressed to the Hon. Sec., Mr. L. H. Crowther, 166, Meadowhead, Sheffield.

• • •

THE RADIO SCIENTIFIC SOCIETY.

All persons interested in wireless will be glad to know that those who remain of the local enthusiasts, who before the war composed the Radio Scientific Society, held a re-union in Manchester on December 3rd, when additional members were enrolled and an active programme was projected.

Though the war has laid a somewhat heavy toll on this Society, great zest for the work remains, as was evidenced by the profitable discussions which ensued after the ordinary business of the meeting.

The Radio Scientific Society will meet every alternate Wednesday evening at 7.30. Intending members and visitors can receive all additional information by applying to Mr. Peter Thomason, Woodside Engineering Co., Ltd., 7, Brazennose Street, Manchester; phone: Central 5735.

• • •

NORTH MIDDLESEX WIRELESS CLUB.

On Wednesday, Nov. 19th, with the President, Mr. A. G. Arthur, in the chair, the above Club held a most successful meeting which was well attended.

After the usual business and the enrolling of new members, the evening was devoted to the question of installing the Club's apparatus and the erection of

NOTES OF THE MONTH.

aerial, etc. Keen competition was displayed among the very enthusiastic members of this Club for the honour of presenting the various instruments, etc., so that before the close of the evening the Chairman was able to announce that the Club had been presented with the aerial mast, the aerial and various instruments, proving that the North Middlesex Wireless Club is a real live Club and that its members are anxious to get to work.

Another meeting of the Club was held on Wednesday, December 3rd, the President being in the Chair. The chief subject under discussion was the most suitable way to erect an aerial pole outside the Club premises and a number of suggestions were put forward by various members. It is hoped that before the next meeting some definite plan will have been decided upon by the Committee.

The Club Library is now well established, and under the able supervision of the President, Mr. A. G. Arthur, will no doubt be of great assistance to members.

Will members kindly note that meetings have been arranged for alternate Wednesdays, commencing from December 3rd, and the practice of sending cards advising the date of the next meeting has been discontinued.

Full particulars of the Club can be obtained from the Hon. Secretary, Mr. E. M. Savage, "Nithsdale," Eversley Park Road, Winchmore Hill, N.21.

• • •

THE DERBY WIRELESS CLUB.

Service members having now mostly returned, the Club is resuming a more active interest in wireless telegraphy. Meetings have been held fortnightly since September, and many matters of interest discussed. All the local members' war experiences seem to

have been with valve circuits, in the Army, Navy, and R.F.C. A member of the latter lately described some achievements in wireless telephony between aeroplanes and their base, over 200 miles away. One of the members of the Committee has had wide experience of D.F. sets and in fitting amplifiers in seaplanes, while another has been responsible for testing and selecting all the high power transmitting valves supplied for the Navy. Several papers on amplifiers, valves, circuits, and curves have been read, and a plasticine model shown representing grid current contours taken from a large American valve. Inductances and capacities can now be measured for members, and a calibrated C.W. wavemeter is available. Valve characteristics can also be taken. The 9th annual meeting is to be held early in January.

• • •

GLASGOW AND DISTRICT RADIO CLUB.

At a meeting of old members held on Thursday, November 20th, it was decided that the activities of the Club be resumed, and the following office bearers were appointed:—President, R. Watson, Esq.; Secretary and Treasurer, R. A. Law, Esq., 7, Queen's Gardens, Glasgow, W.; Committee, Messrs. Gray, Scott Hay, and Adcock.

The next meeting has been provisionally fixed for Monday, January 12th, notification to be sent to members later, and meanwhile the Secretary will be pleased to hear from any of those interested in wireless who care to join the Club.

• • •

THE THREE TOWNS WIRELESS CLUB.

Some months ago it was proposed by W. Rose, the Hon. Sec., that all amateurs should form a League. This was published in several American

- radio newspapers, letters were exchanged between the Radio clubs and an International Society of Radioists was formed. A relay is being formed through Canada and Newfoundland, to Great Britain. The Executive Headquarters have been fixed at Omaha, U.S.A. with the Three Towns Wireless Club as headquarters for Great Britain. The American amateurs number over 100,000, and are going to support the Three Towns Club in anything proposed or done.

November 6th—Much enjoyment was provided by the first of a series of Socials by members and friends of the Three Towns Wireless Club, held at The Lockyer Hall, Alfred Street, Plymouth.

There was an encouraging attendance, and thanks to the energy of Mr. Rose and his Committee (who organized the function) the arrangements left nothing to be desired. Mr. Lemin was M.C. Dancing and games added much to the general amusement, whilst a pleasing musical programme was submitted. The following contributed:—

A Song and Encore by Miss G.

Rose. Concertina Selection by Mr. Percy Brush. Comic Song by Mr. Jerritt, Jun. Song by Mr. Canniford and a Duet by Messrs Burrows and Furneaux. Mr. Fredman was great as a Jazz Band. Mr. J. Jerritt read a letter from Lord and Lady Astor (President and one of the Vice-Presidents of the Club) expressing regret at being unable to attend owing to their recent bereavement. The Refreshments which were free, were ably dispensed by Mrs. Rose and helpers.

November 13th—The evening was spent in Morse practice and in the election of Lady Astor and Mr. E. Blake, A.M.I.E.E., Joint Editor, WIRELESS WORLD, as Vice-Presidents. Mr. J. Jerritt presided.

November 19th—The Chair was taken by Mr. J. Jerritt. The lecture was kindly given by Mr. Greenwood, R.N., on the subject of continuous waves. A simple valve transmitting circuit was shown for the benefit of members who are constructing apparatus.

November 26th—The Chair was taken by Mr. J. Jerritt. The lecture was by Mr. Lock on Accumulators and the process of manufacture was shown.

Amateurs! Why not Write for "THE WIRELESS WORLD"?

We offer amateur wireless men our standard rates for contributions descriptive of their stations, their experiments, the construction of any interesting and useful "gadgets" they may have evolved, or any matter of interest to wireless experimenters. We particularly desire good photographs of stations and club laboratories, or of club groups at

work, at play, or just "posing." All clubs who would like their Officers and Committee to appear in our pages should induce them to face the camera. Send us the photographs and we will do the rest.

NOTE.—An article of fair length accepted and published by us means a new valve for you.

The Wireless Society of London

Proceedings of the Ordinary General Meeting held at the Institute of Civil Engineers on Wednesday, November 26th, at 6 pm.

THE PRESIDENT, MR. A. A. CAMPBELL SWINTON, F.R.S., took the Chair. MR. F. HOPE-JONES, M.I.E.E., in the unfortunate absence through illness of the Secretary, Mr. H. Leslie McMichael, read the Minutes of the previous meeting, which were duly confirmed.

THE PRESIDENT then referred to the list of members and associates passed by the Committee since the last meeting and put up for ballot. A list of these was handed to each member present. The President then an-

nounced that the Committee had decided to appoint the WIRELESS WORLD as the Society's official organ and pointed out the advantages attaching to this arrangement.

MR. J. SCOTT-TAGGART then read a paper entitled "A System for the Reception of Continuous Waves," which was followed by an interesting discussion to which Mr. Scott-Taggart replied.

The meeting adjourned at 7.45 p.m. after the passing of a hearty vote of thanks to the author for his interesting paper.

A System for the Reception of Continuous Waves.

By J. SCOTT-TAGGART.

THE arrangement to be described is of interest largely because it solves in one way the problem of producing a continuous wave wireless receiving circuit capable of "stand-by" and "tuned" adjustment combining ease of manipulation and high selectivity. In addition, the circuits may be adjusted so as to reduce radiation to a negligible value. The complete arrangement was designed by the author and used for certain special artillery communications during the fighting of 1917 and 1918. As evidenced by reports, it proved of exceptional value in battle and overcame the difficulty, previously experienced, of interference by neighbouring "spark"

stations. On several occasions communication was steadily maintained with a forward station 15 kilometres away, although a 2 kilowatt spark set was operating within 300 yards of the continuous-wave receiving station and working on a wavelength only slightly different.

The arrangement may be divided into three essential circuits A, B and C. The circuit B is of the usual type. An aperiodic retroactor coil L_2 is coupled to a variable inductance L_1 ; this coupling is made variable and if sufficiently tight will cause the circuit B to oscillate of its own accord at a frequency determined chiefly by the value of the condenser C_1 . The filament of the vacuum tube V_1 is heated by a six-volt accumula-

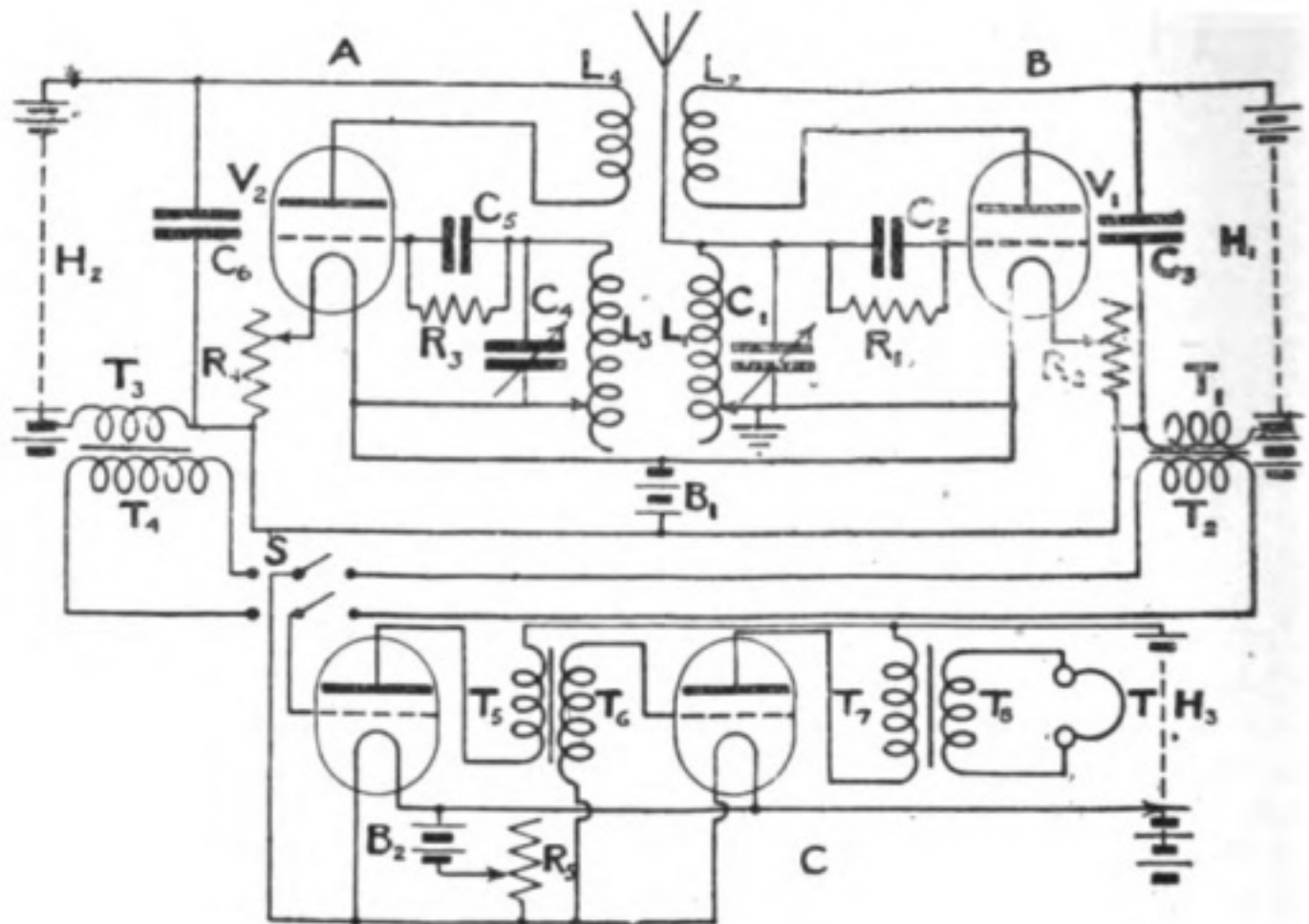

Fig. 1.

tor B_1 through a rheostat R_2 of about 5 ohms resistance. A plate battery H_1 of about 60 volts and the primary T_1 of a step-up transformer T_1 , T_2 are connected as shown, a fixed condenser C_3 of about 0.0008 mfd. being connected across H_1 and T_1 in order to bypass the high-frequency component of the plate current of V_1 .

The portion A is exactly the same as B except that no aerial or earth connection is made. The filament of V_2 is heated by current from the common accumulator B_1 . A double change-over switch S enables any low-frequency current supplied by T_4 or T_2 to be applied to an audio-frequency or note amplifier. C. This circuit C possesses an inter-valve step-up transformer T_5 , T_6 , a telephone step-down transformer T_7 , T_8 , a pair of low-resistance telephones T , a plate battery H_3 of 60 volts, a filament-heating accumulator B_2 and other features

which will be understood by reference to Fig. 1.

The circuit A is placed near to the circuit B so that an inductive effect is obtained. The distance between A and B should preferably be variable and for eliminating interference the author has placed A as much as six feet away from B, although one to two feet is more usual.

While "listening-in," the switch S is placed over to the right and all reception is accomplished by means of the B circuit. The coupling between L_2 and L_1 is adjusted until the circuits commence to oscillate of their own accord. By adjusting C_1 the tuning of the aerial circuit and the adjustment of the local frequency are accomplished simultaneously, and signals from an external C.W. transmitting station are easily picked up. It is to be noted that signals will only be heard if the local frequency is

WIRELESS SOCIETY OF LONDON.

either greater or less than the incoming frequency by between 100 and 4,000. Beyond these limits the beats produced will, for all practical purposes, be inaudible. By gradually increasing the capacity of C_1 continuous wave signals are first heard in T as a high note which will gradually decrease as the capacity of C_1 is increased. A silent point will ultimately be reached, and under these conditions the local frequency will equal the incoming frequency. The aerial circuit will now be exactly tuned to the incoming frequency. As the value of C_1 is increased still further, beats will once more be formed and a note will be heard which will gradually increase in pitch as the capacity of C_1 is increased, until it passes the audible limit.

The signal strength obtained on this circuit B will depend to a certain extent on the value of the coupling between L_2 and L_1 , the plate voltage and the filament current. The cumulative method of grid rectification is employed, a grid condenser C_2 of about 0.0003 mfd. being shunted by a resistance R_1 of about 3 megohms. Apart from the correct choice of a suitable operating point on the grid and plate current curves, we are also concerned with the correct adjustment of the amplitude of the local heterodyning oscillations. This adjustment cannot conveniently be made, a disadvantage which is keenly felt.

It will be seen that for a beat note to be produced the aerial circuit must be slightly mistuned in order to produce local oscillation of a frequency differing from the incoming frequency. The incoming waves force themselves into the aerial circuit in spite of the fact that the latter is out of resonance. While preserving their original frequency the oscillations have their amplitude decreased and cause a loss in signal strength which is very noticeable in the

case of weak signals. The higher beat notes correspond to greater disparities between the local and incoming frequencies. Consequently, a high beat note necessitates a very considerable mistuning of the aerial circuit especially in the case of wavelengths higher than about 500 metres. This fact explains why the loudest signals are invariably obtained on almost the lowest beat notes, since under these conditions the loss of efficiency due to mistuning is at a minimum. If this secondary effect were absent, the loudest beat notes would, in the case of an average pair of telephones, have a frequency in the neighbourhood of 1,000.

The advantage of rapid adjustment, while making the arrangement suitable for "picking-up" signals renders it open to serious interference from spark stations. Another very important disadvantage is that the circuit radiates while receiving. The B circuit acts, in effect, as a small power transmitter which will cause incalculable interference with other continuous wave receiving stations within a few miles' radius. It is safe to say that in nine cases out of ten, the local oscillations are far stronger than necessary. Unfortunately attempts to decrease the oscillating energy usually result in stopping the circuits oscillating or impairing the detector efficiency of the circuit.

The disadvantage of excessive jamming may very largely be overcome by tuning the oscillating B circuit to the silent points of signals, decreasing the coupling between L_2 and L_1 or decreasing the filament current of V_1 so as to prevent V_1 from oscillating, and then switching S over to the left and retuning on the circuit A which is made to oscillate. The complete arrangement now acts as if an aerial circuit were very loosely coupled to the oscillatory circuit $L_3 C_4$. The filament

or plate voltage of V_1 may be dispensed with and signals will still be heard if the circuit A is tuned to oscillate at a frequency slightly different to the incoming frequency. Owing to the very loose coupling between L_1 and L_2 spark signals suffer in amplitude to a much greater extent than continuous wave signals which persist. Another advantage of the arrangement is that the energy radiated from the aerial is merely that induced by the circuit A, which is a negligible amount if the distance between A and B is considerable. The chief disadvantage of the arrangement lies in the fact that considerable inefficiency is caused by the impedance of the mistuned circuit $L_2 C_1$.

A further development which leads to much louder signals is to adjust the B circuit to the pre-oscillatory or sub-generative condition immediately preceding self-oscillation, by increasing the coupling of the retroactor coil L_2 or the magnitude of the filament current, which latter adjustment is preferable. The incoming continuous waves are now retroactively amplified, a phenomenon which has received scant attention as applied to continuous waves. Through the retroactive effect, which partakes of the nature of a negative resistance, the energy losses are decreased and the amplitude of incoming signals increases, much louder results being obtained in the telephones T.

The following simple procedure of tuning is recommended:—

Start with S over to the right; the coupling between L_1 and L_2 and the filament current of V_1 should be sufficient to cause the B circuit to oscillate. Tune C_1 until the incoming continuous wave signals are heard. Tune to the silent point. Now tune the A circuit (which is caused to oscillate) until a steady beat note is heard. Then decrease the filament current of V_1 until

the beat note ceases; this indicates that V_1 has stopped oscillating. Now switch S over to the left and thus listen in on the A circuit. Signals will be heard. By gradually increasing the filament current of V_1 or by the tightening of the coupling between L_1 and L_2 signals may be made much louder. The circuits are now slightly readjusted to give the best results.

It is to be noted that when S is over to the left, any alteration of the tuning of B will only affect the magnitude of the signals without altering their pitch. This is because mistuning B does not affect the frequency of the oscillations which force themselves into the B circuit. On the other hand, any slight alteration of the tuning of A will modify the pitch of signals.

Having now obtained signals on the A circuit let us change S over to the right. Very loud signals will now be heard without any further adjustment. The circuit A is now acting as an external heterodyning circuit which induces local oscillations into the B circuit. The relative amplitude of these oscillations may be varied very conveniently by moving A to a suitable distance from B. The variables of B may now be so chosen that V_1 acts as detector and a retroactive amplifier, but not as an oscillator. Since the circuit B is tuned to the incoming signals, the best results are not obtained when the beat note is low but when its frequency is in the neighbourhood of 1,000. It is true that the circuit B will offer impedance to the local oscillations generated by A which force themselves into the B circuit, yet any loss so occasioned is easily compensated for by bringing A closer to B; no inefficiency is, therefore, experienced.

Although the method of using the circuits just described is by far the most efficient, yet several other arrangements

WIRELESS SOCIETY OF LONDON.

are possible. For example, the B circuit may be made to cause beats with the signals, these beats being then received on the non-oscillating A circuit.

The ratio between the amplitudes of local and incoming oscillations is of great importance and its effect will be very noticeable on the circuit under discussion which allows for considerable variations of the ratio.

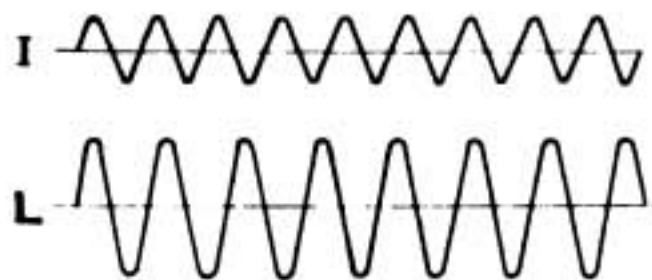

$$\begin{aligned} \text{Mean Resultant} &\propto \frac{(L+I) - (L-I)}{2} \\ &\propto I \end{aligned}$$

Let us suppose that the amplitude of the local oscillations is L and that of the incoming signals is I . We will readily see that the amplitude of the beats will vary from a maximum of $L+I$ to a minimum of the difference between L and I . Suppose that L is greater than I . Then the average beat current, when rectified, will be proportional to $\frac{(L+I) - (L-I)}{2} = I$. Consequently, we can say that when the local current is greater than the incoming current the signal strength will be proportional to the amplitude of the incoming signals. A near-by continuous wave station

would consequently drown a distant station. If, however, the amplitude of the local oscillations is made less than that of the incoming waves, the beat amplitude will vary from $L+I$ to $I-L$. The average rectified current would therefore be proportional to

$$\frac{(L+I) - (I-L)}{2} = L.$$

In other words, unless the local oscilla-

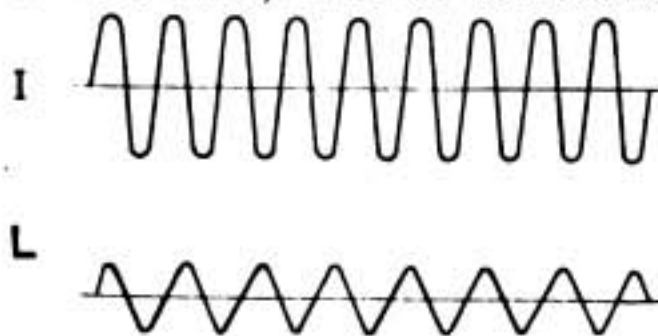

$$\begin{aligned} \text{Mean Resultant} &\propto \frac{(I+L) - (I-L)}{2} \\ &\propto L \end{aligned}$$

Fig. 2.

tions are weaker than the incoming signals, the signal strength is proportional to the amplitude of the local current (Fig. 2). Consequently, a very high-power station would not give any louder signals than a weak distant station. This effect is decidedly useful sometimes to prevent excessive interference.

These theoretical observations are fully borne out in practice and many interesting facts may be deduced from circuits of the type described here.* To

* Vide J. Scott-Taggart, "Some Modern Vacuum Tube Circuits," *Wireless Age*, October, 1919; also J. Scott-Taggart, "Some Practical Notes on the Use of Small Power Continuous Wave Sets," *Wireless World*, April, May, June, 1919.

determine the frequency at which circuits A or B may be oscillating, it is useful to use one of the various types of heterodyning wavemeters which have been devised*

DISCUSSION.

Dr. J. ERSKINE MURRAY expressed interest in the paper, and pointed out that it provided still another example to be added to the already almost innumerable connection schemes for valves. Since it involves the use of three circuits which have to be independently tuned, there are necessarily a number of adjustments to be made when using the apparatus. It would, therefore, appear that the set would be more particularly useful for ground stations. He was discussing it particularly from the point of view of Aircraft and Aircraft work, in which he was particularly interested. For use in aircraft the gear shown would be too bulky and would require too many adjustments as a rule to enable the average operator to manipulate it successfully, but for a ground station for communication with aircraft it would probably be very successful. He also pointed out that in the second arrangement described, when receiving on the B circuit with the A circuit operating as a separate heterodyne, from the mere fact that there is a beat note heard in the receiving telephones it is obvious that there must be some oscillatory energy forced into the aerial circuit and therefore there would be some radiation. The diagrams shown on the blackboard illustrating the effects produced by different ratios between amplitudes of the incoming and the local oscillations were also particularly interesting and gave a clear picture of what one imagines must be taking place in the circuits.

Major N. HAMILTON pointed out that the circuit apparently involved 14 separate adjustments. He also raised the query as to radiation of the heterodyne energy and enquired as to its possible magnitude.

Mr. BASIL BINYON said that it was extremely difficult to criticise the paper without having had experience in the use of the particular circuit described. It appeared to him that one of the chief points raised in the paper was the relative advantages of separate heterodyne *versus* self-heterodyne for C.W. reception, and that it tended to indicate the superior advantages of the separate heterodyne arrangement. When receiving long waves the self-heterodyne involved a very considerable de-tuning of the aerial circuit and in such cases a separate heterodyne is practically essential since the de-tuning becomes so great that the energy picked

from the waves becomes very much reduced. Relative to the author's mention of dimming the valve filament in order to stop it oscillating, he questioned whether this would not be upsetting the conditions of use and possibly losing the advantages of the best conditions. It has been stated that the rectifying properties of a valve are superior when it is oscillating, but he was not altogether certain as to the accuracy of this statement. He also thought that in many cases it is better to couple the aerial circuit to the closed receiving circuit by a loose coupling in preference to the direct connection shown in the paper. He would also like to have the author's views as to the use of the note magnifier shown in the diagram in the paper for the magnification of the heterodyne note. He thought that as a general rule it was found that ordinary note magnifiers did not magnify a heterodyne note to the same extent as they did the note of a spark signal. This possibly may be due to certain resonance effects in the transformers of the note magnifier.

Mr. BROADWOOD made a few remarks relative to the magnification of heterodyne notes and to the use of a detecting valve after the inter-action of the heterodyne.

Mr. PHILIP R. COURSEY said anyone who had done any experimental work with C.W. reception would probably have used receiving coils spaced several feet apart, such as had been described in the paper. Relative to the radiation that might be expected from a separate heterodyne, it was certainly a fact that when using a crystal receiver a very considerable radiation took place when using the separate heterodyne, but when using a valve detector, as described by Mr. Scott-Taggart, the coupling required would be very much weaker and in all probability the radiation would be very considerably reduced, although it is probable that it would still be appreciable. It should be noted that the arrangement described by Mr. Scott-Taggart involved the use of no less than three separate high tension batteries. This, of course, is a considerable disadvantage, particularly from the amateur's point of view, and it raised the question as to whether it would not be more advantageous to use an ordinary high-frequency valve amplifier with a separate heterodyne-coupled to the output end of the amplifier, in order to reduce the radiation. It was well known that very little energy passed back through a valve to cause radiation from the heterodyne, and Mr. Scott-Taggart had recently described a receiving arrangement based on this principle in a recent number of the *Electrical Review*† The difficulties that might be experienced with such an arrangement arise through the very feeble heterodyne power that is required, especially when using a multi-

* Vide J. Scott-Taggart, "Notes on the Measurement of Continuous Waves," *Wireless World*, October, 1917; "Further Notes on the Measurement of Continuous Waves," *Wireless World*, December, 1917; and "A Heterodyning Wavemeter," *Electrician*, p. 243, No. 2155, Vol. lxxxiii., September 5, 1919.

† *Electrical Review*, 85, p. 614, November, 1919.

WIRELESS SOCIETY OF LONDON.

valve amplifier, but with only two or three valves the problem is a very much simpler one and the separate heterodyne does not require a separate high-tension battery since the anode circuit of the heterodyning valve can be supplied in many cases from its own filament battery. Such an arrangement would, therefore, appear to be a much more practical one for the experimenter of perhaps limited means. The drawings made by Mr. Scott-Taggart to explain the addition of a proper proportion of the local oscillations to the incoming oscillations seemed to express the matter very clearly and to give a much more comprehensible explanation of this action than is usually given, such, for example, as the commonly quoted mathematical demonstrations that one finds in the "*Proceedings of the Institute of Radio Engineers.*"

Mr. R. C. CLINKER pointed out that the paper raised the point of the measurement of the frequency of continuous waves. For this purpose an ordinary heterodyne wavemeter may be used, but it might be of interest to draw attention to a very simple method which had recently been described by L. W. Austin, making use of the click which is heard in the telephones when an oscillatory circuit coupled to the circuit of the oscillating valve is tuned to the same frequency. When the coupled circuit is gradually taken through the tuned position two clicks are heard, corresponding to the two frequencies of the coupled circuits, and by loosening the coupling sufficiently these clicks could be brought quite close together. He would like to point out that in his experience this method proves an extremely accurate one in addition to being very simple. He also made a few remarks relative to radiation from the separate heterodyne set.

Mr. BROADWOOD suggested that it would be possible to use the receiving valve only as a detector and then to pass on the rectified energy from this valve to react with a separate circuit which may be made to oscillate at an acoustic frequency and thus get a species of low-frequency heterodyne. Such an arrangement might avoid some of the difficulties of heterodyne radiation.

Mr. HOLUBOWICZ enquired whether he had correctly understood Mr. Scott-Taggart's explanation of the heterodyne, namely, that the amplitude of the resultant heterodyne current was $\frac{(L+I)-(L-I)}{2} = I$

THE PRESIDENT (Mr. Campbell Swinton) said he thought he was voicing the feelings of the meeting in expressing the indebtedness of the Society to Mr. Scott-Taggart for describing this new arrangement. It was true that there are already an extremely large number of valve connections, but that should not hinder us from welcoming any new method.

Mr. SCOTT-TAGGART, in reply, said: Dr. Erskine-Murray and other speakers have

pointed out that the circuits described to-night do not altogether prevent the radiation of feeble continuous waves during reception. This is perfectly true, but my point was that such radiation is almost negligible; that it was conveniently variable by altering the coupling between A and B, and that the radiation would be infinitely smaller than that produced by the simple self-heterodyning circuit, which almost invariably produces local oscillations of unnecessarily strong amplitude.

Major Binyon has raised the very subject I hoped would be discussed, namely, the relative values of self-heterodyne and external heterodyne receiving circuits. He shows an inclination to consider self-heterodyne circuits as the more preferable, provided a separate aerial circuit is used. Such a circuit is actually covered by the present paper. It is used when the indicating circuit C is connected to the A circuit, that is to say when S is over to the left, and when the filament current of V_1 is switched off. The aerial circuit now contains L_1 and C_1 , the retroactor coil L not coming into action. Such an arrangement is not very efficient* if only because the A circuit is tuned to the local frequency and therefore out of tune to the incoming signals induced into A by L_1 , C_1 . Apart from this, however, such an arrangement cannot, and in practice does not, give the same results as when the circuit B is made to influence retroactively the incoming continuous waves. This is accomplished by increasing the coupling between L_1 and L_2 or by increasing the filament current of V_1 until the circuit B just fails to oscillate. The resistance of the aerial circuit is now considerably lessened, and the resultant signals have been found to be at least twice as loud as when my negative resistance effect is not employed. Another result of retroactively amplifying the continuous oscillations before passing them on the rectifying and heterodyning circuit A is that interference from shorter wave stations may be largely eliminated. In this case, however, an addition to the circuit is made by connecting a variable condenser across L_2 .

I am afraid the use of a self-heterodyning circuit with a separate aerial circuit is not likely to find much favour in the future. In addition to the disadvantages enumerated above it is not possible to vary the amplitude ratio between local and incoming oscillations. It is certainly not possible to make the local amplitude less than the amplitude of average incoming signals. We thus fail to get the best adjustment and also lose the valuable effect of lessening continuous wave interference mentioned in the latter part of my paper.

* In the special case where the valve tends to oscillate at the different frequencies, the signals may be retroactively amplified by one of the frequencies and heterodyned by the other. This effect gives loud signals, but the adjustment is very critical.

An alternative arrangement mentioned by Major Binyon, and one very freely used, consists in using an external oscillator coupled to a valve detector or detector amplifier circuit. We now get no loss due to mistuning, and the arrangement is much preferable to the self-heterodyne circuit. The conditions may be reproduced on my arrangement by switching S to the right, making the coupling between L_2 and L_1 very loose and using B as an ordinary valve detector circuit. The results, however, are nothing like as good as when the circuit B is brought to the pre-oscillatory condition and the amplitude of the incoming signals thus increased. The results are considerably better than when S is over to the left, although this latter method of receiving is itself a considerable advance on the more usual systems. It is to be noted, however, that the *selectivity* is highest when S is over to the left, although optimum signal strength is obtained with S to the right. The two valuable effects might be obtained in the one receiving system in the following manner: A separate aerial circuit tuned to the incoming frequency would be arranged. This circuit would be very loosely coupled to a retroactive circuit such as B without the aerial and earth connections and also tuned to the incoming frequency. An external oscillator such as A would now be made to induce local oscillations into B. The amplifier C would be connected to the B circuit. Major Binyon has asked whether the method I suggest for stopping B oscillating and bringing it to a suitable retroactive condition, namely, by lessening the filament of V_1 , is not going to lessen the detector efficiency of V_1 . It is conceivable that it would under special conditions, but, on the other hand, dimming the filament

very often improves the detector efficiency by bringing the operating point to a more suitable position on the characteristic grid or plate current curve. This, for example, would be the case if the voltage of H_1 were small. I prefer the method of varying the filament current, since the adjustment does not alter the tuning of the circuit. Varying the coupling between L_2 and L_1 would, on the other hand, by varying the mutual inductance, alter the tuning of B and a readjustment of C_1 would be necessary.

The same member considers that the valve V_1 will not be such an efficient detector when not oscillating as when it is in a state of oscillation. I am aware that certain much-quoted evidence has been produced on this question, although no other evidence either way has been submitted. My own personal experience is that an oscillating valve is in no way a better detector than a retroactive valve employing an external heterodyning oscillation. The opposite has been the case.

My personal opinion is that self-heterodyning circuits have received undue praise and I think it very likely that in the future they will fade more and more into the background.

Major N. Hamilton has pointed out that about 14 adjustments are necessary. This is far from being the case, although about that number of variables have been provided chiefly to enable the circuits to be used for experimental purposes, and in the numerous ways suggested. The normal adjustments are four. That the arrangement is not unduly complicated and difficult to adjust is proved by the fact that such arrangements were worked by ordinary operators with excellent results during a rapid advance.

It has been asked whether the arrangement

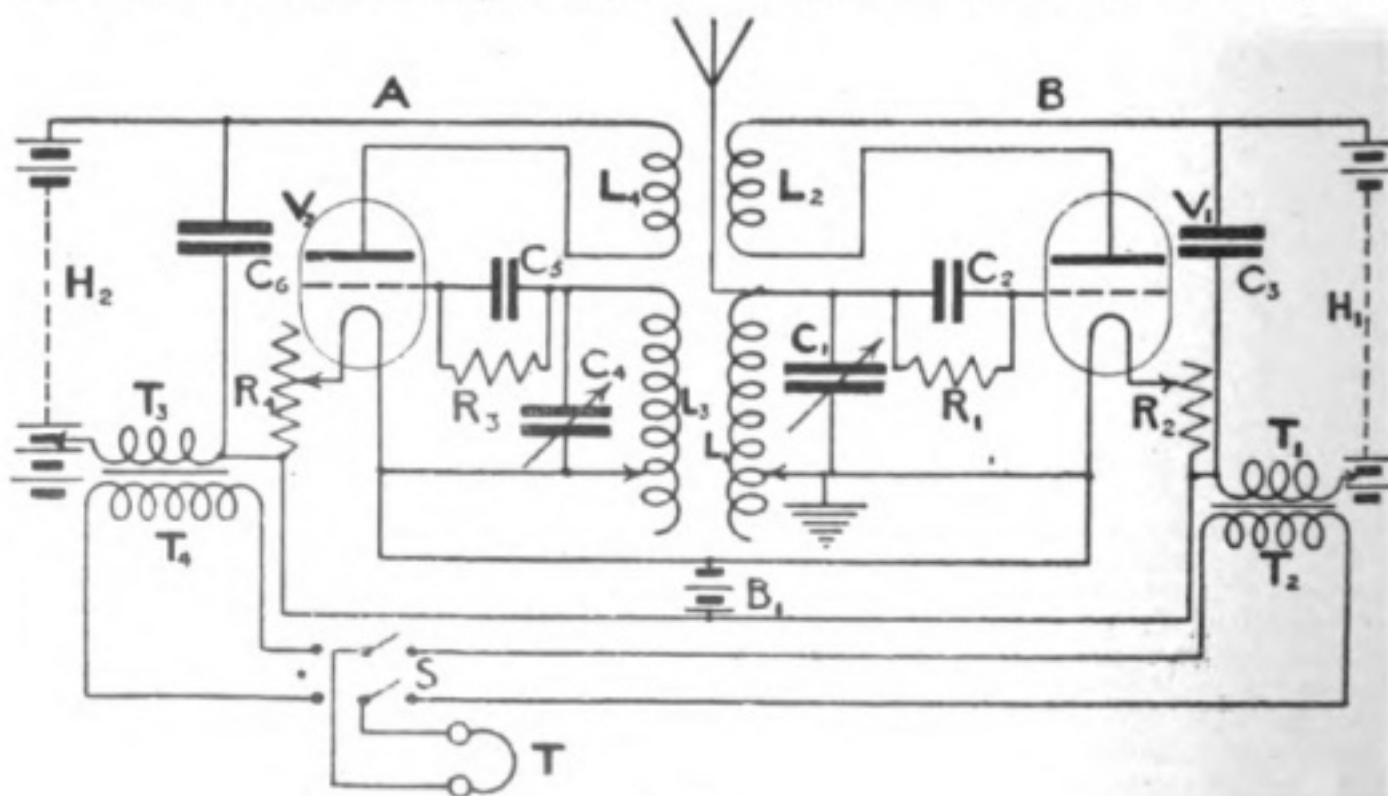

Fig. 3.

WIRELESS SOCIETY OF LONDON.

is suitable for quick search. It is pre-eminently suitable. The preliminary search is first made on the B circuit—a very simple matter. The adjustment of the "tuned" arrangement is then very speedily accomplished by tuning A until the beat note is heard, as described in the paper.

Mr. Philip R. Coursey, amongst other remarks, suggests that the plurality of plate batteries is hardly likely to appeal to the impecunious experimenter. This is true, and the arrangement could be simplified by substituting telephone step-down transformers in place of T_1T_4 and T_1T_2 and connecting low-resistance 'phones across the middle terminals of S in place of the amplifier C. (Fig. 3.) This would, of course, considerably lessen the range of the system. It may be of help to some to point out that the same accumulator B₁ might be used to heat the filaments of the amplifier valves. Alternatively, instead of using a

separate plate battery H₃, tappings might be taken from H₁ or H₂. Both a common plate battery and common accumulator cannot be used at the same time.

One of the speakers asked whether the heterodyning could not in some way be accomplished in the amplifier. This is certainly possible in the case where the amplifier has inter-valve oscillatory circuits. As Mr. Coursey has pointed out, I have described in the *Electrical Review* of November 14, 1919, a two-stage receiver which allows continuous waves to enter, but which prevents all radiation. A modified arrangement would consist in disposing an external oscillator, so that it induced local oscillations into any of the oscillatory circuits (other than those of the first valve) of a high-frequency amplifier-detector. I trust I have replied satisfactorily to the various interesting points raised, and hope that my paper will be of more value to members when in its printed form.

RECORDING OF EIFFEL TOWER TIME SIGNALS FOR DETERMINATION OF CLOCK ERROR.

CAPT. L. B. Turner, who described his valve relay before the Institution of Electrical Engineers last July has now published further information connected with this instrument, in the *Electrician* of November 14th. The experiments described are instigated by a demand for wireless recording apparatus to be used in determination of longitude for survey work in East Africa, and were carried out at the Signals Experimental Establishment, Woolwich. A double magnet chronograph was employed to obtain the records and the Eiffel Tower time signals were used. Two patterns of chronograph were experimented with, the ordinary astronomical Hilder chronograph and the Lindquist chronograph. In the former the records are made by fountain pens, while in the latter the strip is punctured by a sharp point at the beginning of each signal. The latter instrument, therefore, has particular advantages for survey work on account of the avoidance of ink.

Experiments were also performed to investigate the lag in the relay apparatus in order to determine to what extent this would effect the results. The mean of a number of experiments indicates that this lag is of the order of $\frac{1}{200}$ th. of a second. It is therefore generally quite negligible. The great advantage of strip records is that they enable the proper signal record to be sorted out from the marks also made by atmospherics. With a telephone receiver this is extremely difficult in many cases, but owing to the rhythm of the signals the atmospheric trouble, unless very bad, can generally be eliminated by careful measurement of the records. An aerial 200 ft. long and 50 ft. high was used. With this the Eiffel Tower signals could be made to give as much as two or three volts on the grid of the oscillatory valve. This is about ten times as much as is essential, so that the apparatus could be used at very much greater distances from the Eiffel Tower without unduly large oscillations.

Early Experiences of a Wireless Amateur

By W. J. FRY.

ACHAT with our friend the Editor on radio topics in general brought from his lips the remark, "How did you come to start experimenting in wireless?" Well, my desire to do so was the outcome of experiences in electrical work extending over a long period. I was seized with what I may call the short-circuiting craze when but a juvenile of the age of 10 years. A cousin of mine returning from Devonshire excited my boyish imagination by presenting me with a copy of that good old book, "Intensity Coils," by Dyer. Little did I dream in those days of the future which lay before what was then but a comparative toy, the induction coil. No Hertzian waves or Röntgen rays were manifested by its discharge. Indeed little was known of the familiar dark space in the Crookes' tube or of etheric oscillations produced by the spark of the coil.

I shall never forget my delight when I constructed my first voltaic cell of copper and zinc elements with sulphuric acid as electrolyte. I think one of my chief pleasures at the time was to watch the evolution of the gas in the cell, and the thought that current was being forced through the circuit.

My next essay in the realms of practical science was to construct two Bell receivers and a Leclanché cell; unfortunately these were inadvertently mixed up with my mother's dressmaking materials and were in

consequence abruptly confiscated. Nothing deterred by this unfortunate experience my next attempt was in the regions nearer the Heaviside layer. With a pall and the use of a forty-rung ladder a No. 8 galvanised wire was stretched over the houses of the district surveyor and twelve other respectable citizens at the unearthly hour of 4 a.m. and some small attempts at telegraphy were made by means of this aerial wire.



The Author and his first Transmitter.

EARLY EXPERIENCES OF A WIRELESS AMATEUR.

By this time I had begun to appear as a full-blown electrician, and gained some experience with the engineers of the Old Gulcher Electric Light Co., at a West Brompton Exhibition. I shall never forget those old dynamos with their eight field pole-peters as they were then called, and the 8-section Gramme ring armature. Fireworks were not in it whilst these machines were working. Shortly after this my appetite for experiment was fed by the manufacture of a series Siemens' machine. At last having earned the title of Engineer-in-Charge, and having to do with electric lighting and telephone erection, I came to wireless telegraphy. My manager, who was an old Mercantile Captain, one day suggested the operation of the telephone without the use of wires. "Eh, sir," said I, "that will never be." "Never is a long day," he replied. Greatly to my surprise, not long after the Captain buttonholed me, and said, "Look here! here's something for you," and to my



A home-made Wimshurst machine.

amazement, he produced de Tunzelmann's book on Radiotelegraphy (1902). This decided me that I should have to go in for wireless at once. Somewhere about the same date appeared Bottone's book entitled "The Amateur Electrician's Workshop," in which was an account of the construction of a coherer detector. Having now fully developed radio fever, I set to work in earnest, and the year 1902 saw the construction of my first receiver—a coherer. The one-inch coil and oscillators are to be seen on the parapet and photographs of my two Wimshurst machines are shown elsewhere. The proud radio engineer can also be seen on the parapet looking for an announcement that his signals are being received. At first a single wire aerial was dropped from a mast over the parapet (which is 90 feet high) to a depth of 30 feet and an earth lead was taken to the lightning arrester some way back, but 35 feet above the aerial.

On transmission no reception was registered at the receiving station. Remem-



Another Wimshurst machine.

"Door-knobs, sauce-bottles and pieces of old table."

bering the story of the old man who oiled the telephone switch-hook in order to make it hum, I felt inclined to oil the aerial. Instead of this I tried nickel filings in the coherer, with no better results. Then I tried another earth, a proper earth this time, straight to the ground. Eureka! Up went the flag at the receiving station signifying that we were "through." Further experiments, using bell bronze with the coherer gave much more satisfactory results. Then came Popoff's carbon-and-needle detector with increased speed of working as a result. After this I constructed an elaborate set with a coupled inductance, four variable condensers and a Galena-graphite detector. As very often occurs with these ambitious attempts no results were at first obtainable from this apparatus and on investigating the cause the telephones were found to be incorrectly wound, and on re-winding these to 2,000 ohms and introducing the then new detector, fused silicon, excellent results were recorded. Thus were my ambitions realised, but only, of course, for the time being, because as a true radio

amateur I am always looking for something better.

The two Wimshurst machines were constructed from pieces of a mahogany table, door knobs and sauce bottles, and were of great use in my lectures on the coherer receiver.

The photograph of the amateur station (belonging to Mr. Turnbull) shows

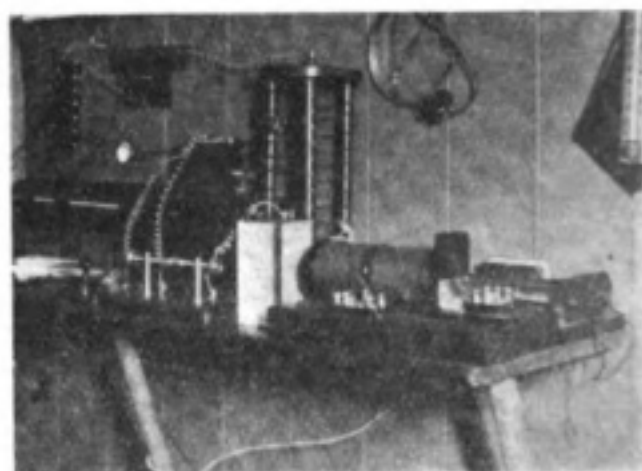

A neat amateur station.

a coupled inductance, tubular condensers and detector of my manufacture. This station was situated at Chalk Farm and used to communicate with mine at Camden Town; its signals also reached Mr. McMichael's station, MXA, at Stondon Park, using 12 watts.

AUDIO FREQUENCY AND RADIO FREQUENCY.

Alternating currents are generated at various frequencies, covering a remarkably wide range. Depending on their application, the frequencies in practical use fall into three well defined classes:

- (a) Commercial frequencies, which nowadays generally mean 25 or 60 cycles per second.
- (b) Audio frequencies, around 500 to 1,000 cycles per second.
- (c) Radio frequencies, usually between 100,000 and 1,000,000, but extending in extreme cases down to perhaps 10,000 and up to several million cycles per second.

Audio frequencies are those conveniently heard in the telephone. When

alternating currents are sent through a telephone, the diaphragm of the latter vibrates. The vibrations are heard as sound. The more rapid the vibrations, the shriller the tone. Vibrations at the rate of 4,000 or 5,000 per second give a shrill whistle, whilst the lowest notes of a bass voice have somewhat under 100.

Radio frequencies occur in the circuits of radio apparatus, for instance in an antenna. They are too rapid to cause a sound in a telephone, which can be heard by the human ear. They can be heard by the human ear.—
(*Radio Amateur News.*)

Aircraft Wireless Section

Edited by J. J. Honan (late Lieutenant and Instructor, R.A.F.).

These articles are intended primarily to offer, as simply as possible, some useful information to those to whom wireless sets are but auxiliary "gadgets" in a wider sphere of activity. It is hoped, however, that they may also prove of interest to the wireless worker generally, as illustrating types of instruments that have been specially evolved to meet the specific needs of the Aviator.

CRYSTAL RECEIVERS.

THE development of the capabilities of the thermionic valve as a rectifier and amplifier, and the consequent design of exceedingly sensitive multi-valve receiving-sets employing both high and low frequency amplification has rendered the crystal receiver obsolete as regards work in the air.

In the earlier days of the war, however, crystal sets, such as the R.N.A.S. type Tb, were used for reception during flight with considerable success, particularly when employed in conjunction with the Brown relay, or with valve amplifiers.

But as a land instrument for the reception of messages sent from the air, the crystal "short wave tuner" proved most successful, and remained in general use right up to the end of the war. In fact the Armistice found some thousands of these sets still on active service in and about the front line area. They were mostly employed in the reception of messages from aircraft engaged on patrol or short-range reconnaissance duties, and more particularly for recording the observations of planes working on "target spotting" in co-operation with the artillery.

The "tuner" and Wireless operator were located under ground, usually somewhere in the vicinity of Battery Headquarters, and it was their combined duty to be always on the alert. Information from the sky-patrol was too valuable to be lost through any carelessness on the part of the W/I Watchdog. Sometimes an emergency S.O.S. from the air would call for barrage fire against an unexpected infantry attack, and occasionally would come the welcome news that a "plum" target was asking for trouble at, say, B5C82 to B5d46. Or, more frequently, a petulant succession of "B's" would signify that observer number so and so of X Squadron was sitting up aloft over a certain Hun target waiting for our battery to finish breakfast and show by means of the usual ground-strip that they were ready to carry on the good work. When this was forthcoming, there would ensue a busy time for the short-wave tuner and its attendant slave, until after an uncertain spell of more or less eloquent Morsing, the aerial spotter would recollect that there was a matter that required his immediate attention in the Mess, and the "pack up" signal CI would indicate that he was going back to see the bar-orderly about it.

Then, with some luck, the S.W.T. and operator might enjoy a little break, for crystal recuperation and mental relaxation respectively until the next R.A.F. cloud arose in the sky.

Meanwhile perhaps it will be as well to give a description of the actual instrument. It is of considerable interest as a type of receiver which was specially evolved to take the unusually short wavelengths radiated by the No. 1 Transmitter, this being the sending-set mostly used by patrol and "target spotting" planes.

As stated previously, the wavelength range of the No. 1 varied between 100 and 300 metres. Specified wavelengths were allotted to adjacent squadrons, and to the component flights of each squadron within these limits. For example the three flights of one squadron would employ lengths of, say, 140, 180, and 220, whilst to the adjacent squadron would be allotted the lengths 160, 200 and 240.

Bearing in mind the number of planes that might be operating simultaneously over a busy area, and the extent of overlapping that was bound to ensue in the areas of active operation allotted to each squadron, it is not difficult to realize that a receiver employed on such work must be an efficient instrument, reliable in operation under the unfavourable conditions inseparable from actual warfare, and capable of a high degree of selective tuning in face of the extraordinary amount of jamming through which it must be able to identify and follow the particular bus with which, for the time, it is working.

ACTION OF THE CRYSTAL RECEIVER.

As a preliminary it may be useful to summarize shortly the general theory of reception by such a set.

The open or aerial receiving circuit responds to electromagnetic disturbances

travelling through the ether, the impact of such waves setting up corresponding variations of e.m.f. (and consequently an alternating current flow) in that circuit. The energy so transferred from the ether to the circuit will be a maximum when the induction and capacity values of the latter are adjusted so that its natural period of electric oscillation synchronizes with the periodicity of impact of the ether waves. When so adjusted the aerial circuit is said to be "tuned" to the given wavelength, and the impact upon it of the series of damped electromagnetic waves radiated during the time-interval of one spark-passage at the transmitter creates a corresponding series of damped e.m.f. variations, each of which forces a small uni-directional current surge through the one-way channel afforded by the crystal, the cumulative effect of these surges being sufficient to give rise to one click in the phones for each spark at the transmitter. It follows therefore that if the spark frequency of the transmitter is, say, 300 per minute, this frequency of "clicks" will be recorded by the receiver telephone and will determine the pitch of the signal note received.

The detector may be placed directly across the open circuit, in which case it is sensitive to all energy impulses received by that circuit and is said to be on the "stand by" position.

Or the energy flow existing in the open circuit may be first transferred inductively to a closed circuit, across which the detector is then placed. This cuts out extraneous disturbances existing in the open circuit, the arrangement being equivalent to a kind of filter which excludes wavelengths other than those to which it is tuned. Such disturbances may exist in the open circuit, but, being relatively weak, are eliminated in the process of inductive transfer between the circuits.

AIRCRAFT WIRELESS SECTION.

The detector when placed across the closed circuit gives selective tuning, and is said to be in the "tune" position.

SHORT-WAVE TUNER (Mark III) GENERAL.

With a standard 125-foot ground aerial of R₄ seven-stranded wire arranged as a single inverted L, wavelengths varying from 100-700 metres can be received on this instrument.

A photograph of the set is shown in Fig. 24, whilst the complete wiring arrangement is shown in Fig. 25.

The detector circuit can be placed either on "stand by" or "time" by means of a change-over switch.

Either a Perikon or carborundum crystal can be used at will, a potentiometer circuit being included with the latter so that the carborundum may be adjusted to the point of maximum sensitivity.

Provision is also made for calibrating and testing the circuits by means of a buzzer, which is automatically inserted in the closed circuit when the detector is used across the open-circuit inductance (i.e., when on "stand by") and is similarly thrown into the open circuit when the detector is across the closed circuit (i.e., on "time"). In both cases the buzzer is inoperative until a special key is closed.

It will be seen from the wiring diagram that the closed circuit is normally broken at K when on "stand by," in order to prevent any transfer of energy between the open and closed circuits, and consequent weakening of signal strength received. For the same reason and as an additional precaution it is advisable, when searching for weak signals on "stand by," to keep the capacity and inductance of the closed circuit at a minimum and the coupling at "loose." In order that the buzzer may operate in

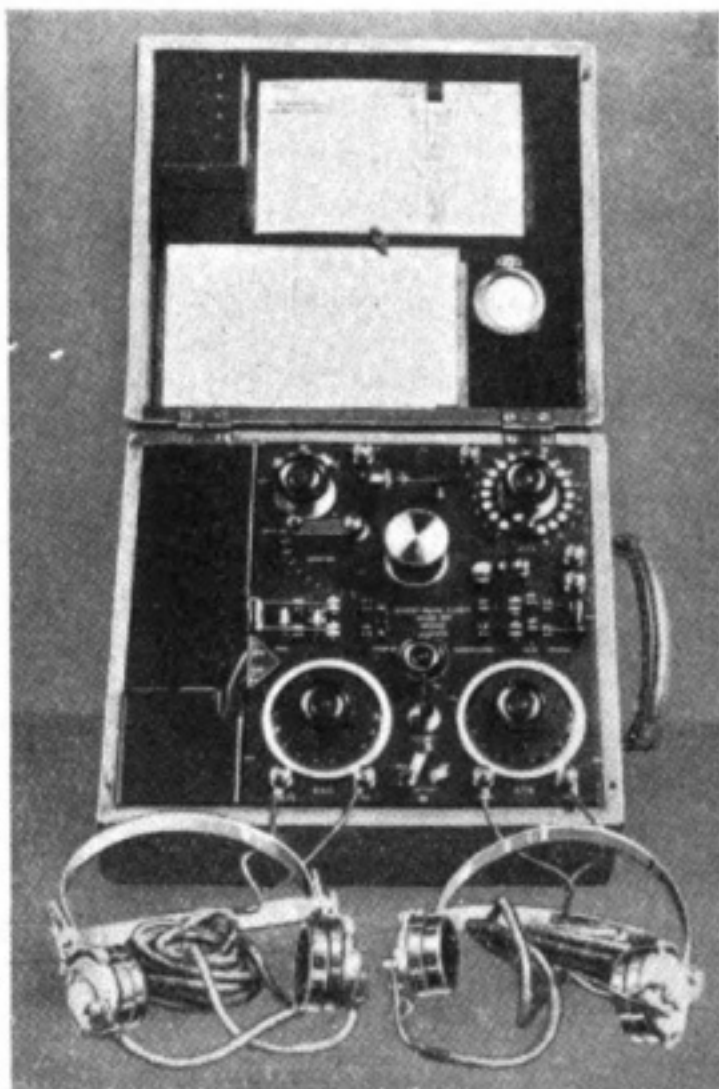

Fig. 24.

this gapped circuit, a key is provided which (a) closes the buzzer circuit, and (b) simultaneously through the insulator block L, shorts the two "gap" leads from the closed circuit.

Having thus broadly surveyed the characteristic features of the set; it may be of interest to describe in brief detail the main circuits involved.

THE BUZZER CIRCUIT.

This consists of a small shunted buzzer fed from two of the four dry cells forming the potentiometer battery. The circuit is normally open, but is brought into action by depressing a small lock button switch, which, as previously explained, simultaneously shorts the "gap" in the closed circuit. The buzzer is used to test and calibrate the circuits,

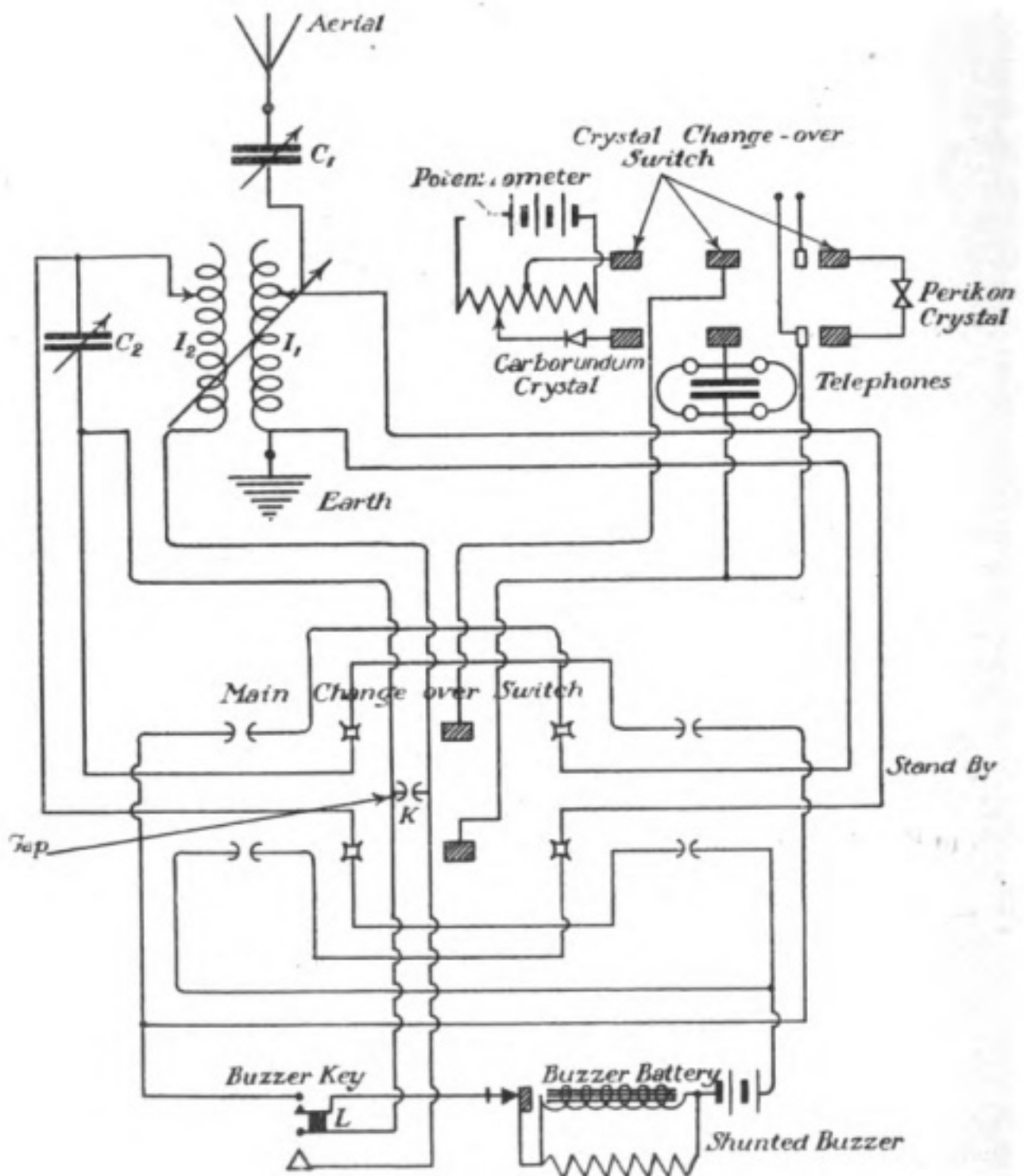

Fig. 25.

and to adjust the crystals to maximum sensitivity.

In testing the crystals, the main switch should preferably be on "stand by" so that the crystals are placed across the closed circuit, this being more constant than the open. The coupling

should be "loose", and the two main circuits set out of tune in order to reduce interaction effects to a minimum.

The phones should similarly be tested by means of the buzzer, and the earpiece adjusted for maximum sound.

(To be continued.)

Aviation Notes

THE TREND AND DEVELOPMENT OF CIVIL AVIATION.

POST-WAR commercial flying was officially inaugurated on the 1st of May of this year. In a recently issued synopsis of the progress of work in the department of Civil Aviation, Major-General Sir F. H. Sykes sets out an account of the steps that have been taken under the aegis of the Government to develop and encourage the latest transport service, and reports the progress that has been made during the initial six months of its existence.

General Sykes has faith in his work. He does not lack foresight, and acknowledges frankly the many difficulties that bar the path of progress, but he is soundly optimistic of the future, and has sufficient courage to look holdly ahead and discern final success. Reliability, safety, comfort, and economy must all be vastly improved before Aviation can play its proper part in the development of civilization. A formidable list of problems certainly, but much progress has already been made, and the remaining difficulties are not insurmountable.

THE AERIAL WAR-ARM.

A feature of the general position that should not be overlooked lies in the fact that a fully developed Commercial Air Service will constitute the main reserve of strength from which the Royal Air Force of the future will draw in time of need. Our War Air Fleet should be capable of rapid and extensive expansion, as well as of the rapid assimilation of large numbers of personnel and quantities of material at short notice. As the Mercantile Marine reinforced the Navy

during the War, so it is to be hoped will civilian aviation form a valuable auxiliary to the Royal Air Force should a time of crisis arise. This source of supply can only be satisfactory and adequate if our commercial air fleet is in itself a healthy and well-developed factor. This entails the growth of a steady demand for quicker communication, built up on a reliable and adequate Air Service.

CARRIAGE OF MAILS.

The carriage of mails, as has already frequently been pointed out, promises to form one of the most important and regular demands to be supplied by civil aviation. More than any other service at present, it could be utilized as a means for placing aerial transport enterprises upon a firm footing.

The Postmaster-General, it would seem, is doubtful whether the demand for express mails between the more distant towns in the United Kingdom is likely to be sufficiently extensive to meet the considerable expense of running such a service for mails only. But if commercial services were established for passengers and small goods, he would seize the opportunity to utilize them for the despatch of express letters under suitable subsidy.

A more promising line of development for aerial mails would seem to be more along the Continental and Imperial routes where the long distances give more pronounced scope for the element of speed.

THE QUESTION OF SUBSIDY.

Whilst he considers it a vital matter that civil aviation should grow and pros-

per, General Sykes recognizes that the new industry is hardly as yet able to stand on its own feet. He suggests three methods of assisting it: (a) By means of direct Government subsidies, as in France, where already 18,000,000 francs have been earmarked for this purpose. (b) By recognizing that *at the beginning* the British aircraft must, in order to ensure its persistence, be afforded some form of direct Government assistance, no matter how foreign this may be to usual British practice. Such aid might reasonably take the shape of a specified subsidy to approved aerial transport companies on the basis of mileage flown and weight carried. (c) By generous assistance in material and information; for example the provisions of certain "key" aerodromes and shed accommodation at home and on the Empire routes. Also the collection and distribution of meteorological and other data, and the provisions of an adequate communication system.

* * *

INTERNATIONAL FACILITIES.

Pending the coming into operation of the International Air Convention, temporary agreements have been concluded with Belgium, France, Holland, Italy, and Portugal, while permission for individual flights has been obtained from Denmark, Spain and Switzerland. Steps have since been taken which it is hoped will ensure the subscription of Holland, Spain and Switzerland to the Convention at an early date, and subsequently of the Scandinavian Countries, so that one code of rules for the air will be in force throughout Europe.

Every possible assistance in this direction has been given to those firms to whose enterprise are due the existing services between London and Paris, London and Brussels, and London and Amsterdam.

PROGRESS ACHIEVED.

As to the practical results obtained within the period of time covered by General Sykes' report, the following approximate figures have been voluntarily furnished by certain of the firms actually engaged in civil air traffic to indicate the extent of work carried out. In view of the mileage covered, the number of accidents must be regarded as remarkably small:—

No. of hours flown	4,000
No. of flights	21,000
No. of passengers carried	52,000
Approximate mileage ...	303,000
Total accidents	13
No. of fatal accidents ...	2

Both of the fatalities occurred to pilots. In no case was the life of a passenger lost.

It will be noticed that the great majority of the flights were of short duration. Mainly, no doubt, they were of the seaside joy-ride variety, and are to be regarded as of an educative character. But in view of the fact that the most fertile source of accident is in "taking off" or "landing," the proportion of accidents to "flights made" is a truer guide than that for "hours flown." The figures certainly demonstrate the importance that the firms concerned place upon the maxim of "safety first" for the flying public.

* * *

THE WIRELESS ASPECT.

The importance of wireless as an auxiliary to aviation has been fully realized. Considerable attention has been given to the improvement and increasing scope of wireless telegraphy and telephony, as well as to the perfecting of directional wireless as a means of aerial navigation. Wireless stations have been erected at Hounslow and Lympne, and wireless liaison has been established with the French for the purpose of the London-Paris air route.

The Library Table

TEXT BOOK ON WIRELESS TELEGRAPHY.

By RUPERT STANLEY, B.A., M.I.E.E.
(London: Longmans, Green and Co.,
two vols.: pp. xiii+471, and
ix+357, price 15s. each).

THIS book was originally written in 1914 as a single volume, but with the recent rapid growth of wireless work the author has found it necessary to issue the new edition in two volumes. In this way the original layout has been very largely retained in the first volume, while the modern developments of the hard vacuum tube are extensively described in the second.

As compared with the original book, the first volume of the new edition contains additional chapters entitled "Synchronous, Asynchronous, and Resonance Sparking—Faults in Transmitters" and "Secondary Cells and Batteries," while other rearrangements of the matter have been made—notably in the order of treatment of some of the parts, and in the dividing up of old chapters into two new ones—*e.g.*, the chapter on "Capacity and Induction effect," is now divided into two. The appendices have also been modified. In place of the list of British coast stations a short combined British and foreign list has been given with the names and call letters of the most important and high-power stations in the northern hemisphere—but mainly in Europe; in addition a list of the international initial call letters allotted to various countries is also given. The extracts from the International Radiotelegraphic regulations have been omitted from the new volume, as have also the particulars of the Eiffel

Tower time and weather signals. In their place a Table of Trigonometrical Ratios is given. There is one thing to be said in favour of this change—that trigonometrical functions are permanent (unless perhaps Einstein or some other mathematician finds out that they are only relative) whereas the Eiffel Tower signals, and especially the weather reports are subject to change.

As far as the general scheme of the work is concerned little can be said—the original was good, the new is equally good, or rather better, while most of the few errors in the original have been corrected.* A word may perhaps be said about page 191. In discussing the use of step-up transformers for small (experimental, etc.) stations operated directly from the A.C. mains, the author refers to transformers as made by various American manufacturers and quotes 1914 prices for them. It is altogether questionable to what extent such a practice is desirable for a text book, as although it is very useful in, say, a constructional article in an experimenter's periodical to give the amateur some idea of the cost of his apparatus, such figures are practically valueless in a text book that presumably will be used for more than a year or two.

The chapter on "Some Measurements in Radio-telegraphy" has been very considerably revised, and a quantity of useful and very practical information has been incorporated. This information is in a form particularly useful for the experimenter, since not only are the methods described, but practical details are given by which the amateur can con-

* That on p. 105 (Vol. I.) relative to the material of spark gap electrodes has, however, been passed over.

struct and carry out such tests himself—such for example as the wavemeter windings given on p. 414. The method of measuring the effective resistance of the aerial, described on p. 421 is, however, somewhat crude, and no mention is made of the effect of losses in the condenser and inductance of the dummy aerial, although at times these may occasion a serious error in the results.

Volume II, although incorporated as part of the whole text book, is arranged in such a manner that it can well be considered on its own merits, and provides a good account of modern valve practice. It opens with a chapter on "Electrons," in which a good deal of the material already dealt with in Chapter II, Vol. I., is again passed in review as an introduction to the processes taking place in valves. Parts of this, however, relating to the constitution of the elements in the Periodic table, although making interesting reading, are not so relevant to the matter under discussion, as is the remainder. The mode of operation of a valve, and the theory of the modern "hard" valve are extensively dealt with in Chapter II., the explanations being illustrated with actual characteristics of "French" valves, in preference to the imaginary characteristics so commonly given in this connection. An extensive and interesting collection of characteristics of French and other valves is also given in Chapters IX. and X.

The "detector" action of the valve is discussed in Chapter III., and high-frequency amplification in Chapter IV.

Up to this point very little mathematics has been introduced, but in Chapter V. on the Valve as a Generator of Oscillations, the mathematical theory of the production and maintenance of oscillations is given. A knowledge of differential notation is assumed. Most of this material is particularly valu-

able and contains the results of the most recent work on these lines.

The next two chapters describe a number of circuit arrangements for low-frequency and high-frequency amplifiers respectively, while Chapter VIII. deals with heterodyne reception and with the relative advantages of self- and separate-heterodyne—here termed Autoheterodyne and Ultra-heterodyne respectively.

Hull's Dynatron and other patterns of special American valves are described in Chapter XI., and the mathematical relations of the former are given from Hull's *Institute of Radio Engineers'* paper. Various C.W. and Radio-Telephone Transmitters and receivers are well described in the three following chapters, which are followed by a brief résumé of other forms of radiotelephone transmitters.

Chapter XVI. strikes a different note to the remainder of the volume. It describes various arrangements for earth current signalling, and in particular the developments of this method of communication that have taken place under the stimulus of trench-warfare and similar stringent requirements.

The book concludes with descriptions of miscellaneous valve apparatus—C.W. wavemeters, valve telephone repeaters, "tonic-train" transmitters and similar arrangements of a special nature. It would appear that the second volume in particular should be eminently suitable not only for students, but for the radio-engineer as well. Both volumes are very well printed and the diagrams and illustrations clear, while each has a separate index. The author's practice of putting a few questions at the end of each chapter has been adhered to in both volumes. These questions are intended mainly for the student for self-examination, rather than as ordinary examination questions or problems.

The Construction of Amateur Wireless Apparatus

This series of articles, the first of which was published in our April number, was originally designed to give practical instruction in the manufacture of amateur installations and apparatus, and arrangements had been made with Marconi's Wireless Telegraph Co., Ltd., to supply complete apparatus to the designs it was intended to detail. The restrictions on amateur work, however, remained in force, and the author was compelled to proceed on general lines only. A further series will be published giving the class of information originally intended.

Article Ten.—HIGH-TENSION SUPPLY.

IN our last article we made some suggestions to assist the amateur over his difficulties in obtaining a supply of current at a high voltage without rendering the cost prohibitive. This question is undoubtedly one of the most serious the average experimenter has to face when he commences his work with the three-electrode valve, and the discovery of a simple and cheap form of supply would form a very suitable field of investigation. By the solution of this problem—more particularly in the case of receiving valves—the amateur could render very valuable aid in the development of wireless telegraphy.

The actual power required for the operation of a receiving valve is very small indeed, being only of the order of $\frac{1}{30}$ th. watt. The difficulty lies in the fact that this energy *must* be delivered at a high voltage. Very small motor generators have been suggested for this purpose. The motor could be arranged to run from a four or six volt accumulator battery, in fact there is no reason why the same accumulator should not be used for lighting the valve filament and supplying the current for the

motor generator. The main trouble in this arrangement is due to the fact that it is difficult to make a small generator which will give a sufficiently uniform voltage at the brushes, with the result that noises are caused in the telephones. These generator noises are due to

- (1) Ripples caused by the teeth on the armature.
- (2) Slight sparking at the brushes.
- (3) Microphonic contacts between the brushes and the commutator bars.

Ripples due to the armature teeth are difficult to suppress in the machine itself, but can be considerably reduced by the use of smoothing out chokes and condensers as described in the last article. In any case such ripples do not interfere to a great extent with reception, provided of course that they are not too strong, because the sound produced in the telephones is a continuous hum, through which it is found in practice quite weak signals can be read. This is particularly the case if the note produced by the ripples is not of too high a pitch.

Noises due to sparking at the commutator are most difficult to eliminate. The sparks result in the radiation of highly

damped short waves from the machine itself, and these impulses cause the tuned circuits associated with the valve receiver to oscillate with the frequency corresponding to the wavelength to which they are tuned. Since these impulses are actually radiated it is sometimes possible to reduce their effect considerably by completely enclosing the generator in an earthed metal box. A large condenser connected across the brushes is also effective. In any case it is most essential that the design and adjustment of the machine should be such that there is no visible sparking at the commutator.

Microphonic action between the brushes and the commutator bars can be reduced by the smoothing out circuit previously mentioned. It is necessary that the commutator should be kept clean and that the brushes should be a good fit on it. If the brushes have not the same radius of curvature at the working face as the commutator, sparking and microphonic contacts may be introduced under the surface of the brush in which position the sparks may not be visible.

Noises are also often introduced by the motor driving the machine. Great care should be taken to secure sparkless commutation here as in the case of the generator. If the fields of both machines are fed from the same low voltage battery, any impulses produced by the motor armature may be reproduced in the generator voltage owing to fluctuations in the intensity of the fields. It is partly for this reason that the generator is often fitted with a permanent magnet field. This renders the machine more bulky because the intensity of the flux produced by a permanent magnet is very much less than in the case of an electromagnet. It should also be noted that the shafts of the two machines should be joined by means of an insulat-

ing coupling of some type, the machines themselves being mounted up on a bed-plate of stabilite or other insulating material. It is essential that they should be kept quite separate electrically.

It has also been suggested that a thermopile would form a very convenient means of generating the necessary current for the plate circuit of the valve. No batteries or acid are required and there are no moving parts, the current being generated directly from the heat of a lamp. The difficulty in this case lies in the fact that the E.M.F. generated per couple is very small. For example, in the case of a copper-constantan couple, if the hot junction is maintained at a temperature of 300 degrees Centigrade hotter than the cold junction, the E.M.F. per couple is only of the order of one hundredth of a volt. The experimenter will thus see that a large number of couples will have to be connected in series to give the desired E.M.F. If any means can be devised for making the couples automatically in large quantities and to occupy a small space the idea might be worked out.

The above notes are offered with a view to giving the amateur a line which might be developed and which would be of immense importance in practical wireless if the problem could be satisfactorily solved. Much valuable information has been the result of amateur work prior to the war, and now that the restrictions are being gradually relaxed there is much useful new work for the experimenter to take up.

Before we leave this subject of the high tension supply there is one simple way of running both filament and plate circuits from one supply to which we will refer. An application of the idea is illustrated in Fig. 1, the circuit in this case being that of an independent heterodyne. The oscillating circuit A consisting of an inductance shunted by a vari-

CONSTRUCTION OF AMATEUR WIRELESS.

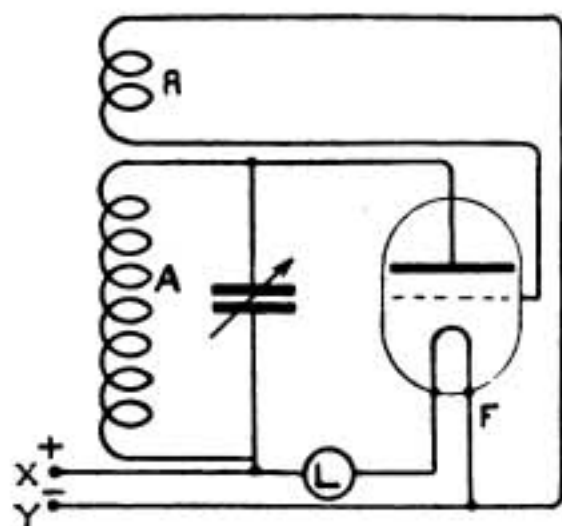

Fig. 1.

able condenser is connected in the plate circuit of the valve. X and Y are the terminals of a supply at a voltage suitable for the plate circuit of the three-electrode valve. A lamp of the correct candle power to pass the right current for lighting the valve filament is connected as shown in the *positive* lead of the supply, the filament being in series with this lamp. Such a lamp can easily be found by selection from a number of different voltages and candle-powers. The average valve filament takes about half an ampere to run it at normal brilliancy. The filament can, in this way, be lighted from the high-voltage supply and the accumulator battery is dispensed with. The plate circuit of the valve is connected to the positive terminal of the supply, and the grid is connected to the negative terminal *via* the reaction coil R. The action of the circuit can be understood by the aid of an example.

Suppose that the amateur has available 110 volts direct current. Now the valve filament will probably take about half an ampere at four volts. A 110 volt 16 candle power lamp will pass about the right current to light the filament. As soon as the circuit is closed the E.M.F. will be distributed in the proportion of four volts across the filament and 106 across the lamp. Since now one leg of the filament is directly connected to the negative terminal of the supply and the plate is connected through the oscillatory circuit A to the positive terminal, we shall have the full 110 volts acting between plate and filament; and the grid will be, as usual, at the potential of the negative end of the filament. The potential conditions are therefore normal, and the circuit will oscillate if a correct adjustment of the reaction coil R is made. Of course it is necessary to choose a valve of such a design that the supply voltage is suitable for application to the plate.

The amateur will easily be able to work out for himself the necessary circuits for the application of the idea to the schemes of connections which have been given in previous numbers. The protecting fuses, etc., should always be included as before indicated; for simplicity's sake we have not shown them in Fig. 1. The arrangement will be found more suitable for high-frequency magnification than for note amplifying circuits. There is always more difficulty in silencing a note amplifier when operated from a machine-fed supply.

AMATEURS, PLEASE NOTE !

Do you belong to a Wireless Club? If not, you are probably not pulling your weight. What amateurs in this country need is a strong club movement backed by an affiliation. We shall be pleased to give you information about the clubs in your district, or to assist you in starting one.

If you wish to see Amateur Wireless win a dignified footing, join a club, help a club, or make a club.

Questions and Answers

NOTE.—This section of the magazine is placed at the disposal of all readers who wish to receive advice and information on matters pertaining to both the technical and non-technical sides of wireless telegraphy. Readers should comply with the following rules:

- (1) Questions should be numbered and written on one side of the paper only, and should not exceed four in number.
- (2) Queries should be clear and concise.
- (3) Before sending in their questions readers are advised to search recent numbers to see whether the same queries have not been dealt with before.
- (4) The Editor cannot undertake to reply to queries by post.
- (5) All queries must be accompanied by the full name and address of the sender, which is for reference, not for publication. Queries will be answered under the initials and town of the correspondent, or if so desired, under a "nom-de-plume."
- (6) Readers desirous of knowing the conditions of service, etc., for wireless operators will save time by writing direct to the various firms employing operators.

A.G. (Bayswater).—The British School of Telegraphy, 179 Clapham Road, S.W. The East London Wireless Telegraph Training College, 172a and 228 Romford Road, Forest Gate, E. Both of these Schools hold evening classes.

W.J.H. (Kirkham).—Write to Secretary, G.P.O. He will probably let you know the nearest examination centre; and his Handbook for Wireless Operators contains the fullest details of the examination.

H.S.H. (Bristol).—The design of static frequency raisers is to a certain extent the manufacturers' secret and very little is published on the details of the subject. However, refer to Dr. Fleming's well-known manual of Radiotelegraphy, Dr. Eccles' "Wireless Telegraphy and Telephony" and Zenneck's book on Wireless.

W. R. Clark.—(1) We should think you are well qualified to instruct. (2) No certificates are necessarily required, the posts being given to men of the best experience and greatest efficiency. (3) There are no official regulations governing the matter unless you refer to instructorships under government control, such as in the Army or Navy. The only certificate of recognised value is issued solely by the Postmaster-General. (4) This question, therefore, does not arise.

W.J.T. (Co. Armagh).—Please see reply to "Constant Reader" in the Dec. number.

W.H.R. (Horsforth).—"The Thermionic Valve and its Developments in Radio-Telegraphy and Telephony," by J. A. Fleming, D.Sc., and "The Oscillation Valve: The Elementary Principles of its Application to Wireless Telegraphy," by R. D. Bangay. For telephony you might read "Telephony" by Alfred N. Goldsmith. The Wireless Press has published a book on Wireless Telephony by Mr. Philip R. Coursey. (2) Yes, the International Correspondence Schools have such a course.

C.L. (British Rhine Army).—To qualify for the Mercantile Marine War Medal you must have served at sea for at least six months between August, 1914 and November 11th, 1918 and, in addition, at least one voyage through a danger zone during that period.

"PITCH," (Devon).—(1) Pitch would make suitable lining for wooden cases for cells providing there was no crack in the surface to allow any of the electrolyte to leak through.

(2) You do not seem to understand the ordinary secondary cell. You cannot make a plate positive on one side and negative on the other. In the simple secondary cell are two lead plates in sulphuric acid. When a current is passed through the cell, that is when they are charged, one plate becomes coated with lead peroxide while the other remains unaltered. Then when the cell is connected to a discharging circuit a current will flow in the circuit due to chemical action in the cell.

Now any number of plates can be connected up in the cell, but one-half must be connected to the positive plate while the other half is connected to the negative plate. This increase in the number of plates does not increase the voltage of the cell, but allows a greater current to flow owing to the greater surface of plate exposed to the electrolyte and consequently a lowering of the resistance of the cell. Hence if more than 2 V. (the average E.M.F. of a secondary cell) are required, it is necessary to connect separate cells in series. From your sketch it seems that you expect your arrangement of plates to give you 10 V.

A mixture of litharge and sulphuric acid for the negative plates, and a mixture of red lead and sulphuric acid for the positive plates is now generally used.

G.L.R. (Cornwall).—(1) It is quite true that trees can be used as receiving aerials. This is because a tree acts to a small extent as a conductor of electricity, and when the electro-magnetic waves of a transmitting station come into contact with the tree a very feeble

QUESTIONS AND ANSWERS.

current is induced in the tree. The tree has, of course, a very good earth connection through its roots, but is in itself a bad conductor.

General Squier, of the United States Army, first utilised trees as receiving aerials about 15 years ago, and has recently carried out further experiments with them.

(2) Owing to their comparatively high resistance only the modern valve receivers are of use in detecting the feeble induced currents, the valve receiver being tapped off the tree trunk.

"RADIO" (Kensington).—(1) The natural wavelength of an aerial 90 feet long with a down-lead 10 feet long, is approximately 400 feet, or roughly, 120 metres.

(2) It would be quite a simple matter to receive a station with this aerial 90 feet high, but how do you arrive at a 10-foot down-lead?

(3) The apparatus you mention is sufficient for receiving purposes.

(4) It is quite impossible for us to give you any figures for the aerial tuning inductance, as you do not mention to what wavelength you wish to tune your aerial.

"IMPATIENT" (Braintree). — (1) The blocking condenser across the secondary of a telephone transformer is still used with some receivers. It is often left out of diagrams of connections for the sake of clearness, and because it is not an essential part of a receiver. It is used in order to tune the note frequency of the received waves and is usually adjusted by the operator to suit himself.

(2) You make no mention of what you believe are the values of your inductances for the various wavelengths you receive. We suppose you worked these out when you originally wound your coils, or did you do this by experiment alone? The inductance required with a capacity of .00003 mfd. to receive 600 m. is roughly 3,380 mhy., and that required for 2,500 m. is 58,500 mhy., and it seems to us quite possible that your circuits were not properly in tune in your original arrangement.

Have you a wavemeter? If so, why not buzz the circuit and measure the wavelength with the wavemeter. If you do not possess one we strongly advise you to make one as you will find it most useful.

(3) The reason you get signals from loud stations with your earth lead disconnected is probably due to a capacity leak to earth, that is a leak from your secondary circuit through the telephones and yourself to earth.

W. R. B. (Birmingham).—It is quite true to say that the earth acts as a magnet with its N. pole at the South geographical pole, and its S. pole at the North geographical pole.

If a magnet is suspended so that it can rotate in a horizontal plane, it will take up such a position that its N. end will point to the geographical North, and the other end will point to the geographical South. This is of course in accordance with the "First Law of Magnetism."

It must be remembered that the end of the magnet marked N. is the "North (geographical) seeking end."

The writer has always advocated the view that it would be more convenient and logical to mark the North-seeking end of a magnet as +

The magnet with which you made your test has evidently had its magnetisation reversed, thus causing its North-seeking end to point to the South geographical pole.

H.M. (Warrington).—(1) Full particulars of the P.M.G. examination may be obtained from the Secretary, G.P.O., London.

(2) Apply to Marconi's Wireless Telegraph Co., Ltd., Marconi House, Strand.

(3) Apart from the firm you mention, there are very few employers of wireless operators in this country. You might try Siemens Bros., or, better still in your particular case, one or other of the Railway Companies who run wireless installations in connection with cross-Channel services.

"SPARKS, R.N."—Questions (1) and (3). Apply to the Secretary, G.P.O., London. (2) The fee is 5s. (4) Transmission, reception, fault-tracing, thorough knowledge of apparatus and its wiring diagrams, and rules for working traffic. Get the P.M.G.'s Handbook and Hawkhead's "Technical Instruction for Wireless Telegraphists" (The Wireless Press, Ltd.)

B.C. (Southport).—Please see Note 4 at the head of these columns. The Liverpool Wireless Telegraph Training College, 27, Leese Street, Liverpool.

The reply in our last issue, which was headed "Constant Reader," should have been referred to W. J. T. (Co. Armagh).

PATENTS, Inventions, Trade Marks.—Advice and handbook free.—King's Patent Agency, Ltd., 165, Queen Victoria Street, London, E.C.4.

TECHNICAL BOOKS. Second-hand and New Books on every conceivable subject. Catalogue free. State wants. Books sent on approval. Books bought.—FOYLE, 121/125, Charing Cross Road, London.

LEARN DUTTON'S 24-HOUR SHORTHAND; booklet free.—DUTTON'S COLLEGE, Desk D101, Skegness.

WANTED. The following number of "WIRELESS WORLD" —March 1918. Fair price. P. G. THOMASON, Hazel Road, Altrincham.

MR. R. J. SOWTER, B.Sc., A.R.C.S., Barrister-at-law and Fellow of the Physical Society, an Examiner in H.M. Patent Office, has been appointed by the Admiralty to the R.N. School of Signalling, Portsmouth, as Head of the Patents Section.

Company Notes

MARCONI'S WIRELESS TELEGRAPH COMPANY, LIMITED.

NEW CAPITAL ISSUE.

EXTRAORDINARY GENERAL MEETING.

AN EXTRAORDINARY GENERAL MEETING of Marconi's Wireless Telegraph Company (Limited) was held on November 28th, at the registered office of the Company, Marconi House, Strand, for the purpose of confirming as a special resolution the resolution passed on the 13th inst., providing for an increase in the capital. Mr. GODFREY C. ISAACS (deputy-chairman and managing director) presided. The other directors present were Messrs Henry W. Allen, F.C.I.S., William W. Bradfield, C.B.E., Maurice A. Bramston, Alfonso Marconi, and Sidney St. J. Steadman.

The SECRETARY (Mr. H. W. Corby, F.C.I.S.) having read the notice convening the meeting,

The CHAIRMAN said: Gentlemen,—This is an extraordinary general meeting for the purpose of confirming the resolution to increase the capital of the company, which was passed unanimously at the meeting on the 13th of this month. Before submitting the resolution I would remind you that on that occasion I said I felt sure this country would soon wake up to the necessities of the times, and eventually would demand, and the Government would recognize, that it requires the latest and best possible chain of wireless stations. I added, "when the day comes, and it may be very soon, we propose to be ready."

You will have read in the Press that the Secretary of State for the Colonies, as Chairman of the Imperial Communications Committee, has, with the approval of the Cabinet, appointed a Committee to complete a scheme of Imperial wireless communications in the light of modern wireless science and Imperial needs. That Committee has to decide what high power stations it is desirable on commercial or strategic grounds that the Empire should ultimately possess, to prepare estimates of the capital and annual costs of each station, the life of the plant and buildings as taken for the calculation of the depreciation to include an adequate allowance for obsolescence, to examine the amount of traffic and revenue which may be expected from each station, and to

place the stations recommended in their order of urgency. These are the terms of reference.

APPLICATION FOR LICENCES.

When these informations are in the possession of the Cabinet, I understand they will then decide whether or not the stations will be erected for account of the State, whether private enterprise shall be licensed to erect them for their own account, or, as a possible third alternative, whether they shall be erected by private enterprise conjointly with the State with State control. I have already on a previous occasion informed shareholders that we had applied to the Imperial Communications Committee for licences to erect and work these stations. We have also intimated our willingness to enter into an alternative arrangement under which we would erect them conjointly with the State, leaving to the State effective control.

These proposals have been under consideration, and the appointment of a Committee by the Secretary of State for the Colonies as Chairman of the Imperial Communications Committee, to advise what stations are required, is, I hope, a step towards securing to the Empire a chain of wireless stations of the latest and best system, comprising all the recent important improvements in wireless communication. Such a network of wireless stations, connecting up the distant parts of the Empire, and so arranged as to communicate with all the other parts of the world, which we can facilitate either through our own stations or through those with which we have priority of service, will furnish a much-felt need in all industrial centres and materially strengthen our hands in the world's competition for trade.

I would also remind shareholders that this company alone possesses for the British Empire all the efficient commercial wireless systems, besides having the sole right of all new patents and improvements, so far as the Empire is concerned, in those systems, even when they originate from any of the important wire-

COMPANY NOTES.

less companies in foreign countries, and also the benefit of any and every patent which may emanate from the General Electric Company of America, in so far as it may relate to wireless telegraphy or telephony. The chairman concluded by moving the resolution.

Mr. M. A. BRAMSTON seconded the motion.

FACILITIES FOR STUDENTS.

The CHAIRMAN, in reply to shareholders' questions, said he had seen a notice in the Press intimating to wireless students that, the war now being over, licences to wireless students would be freely given by the Post Office, both for the transmission and the reception of messages. It would be understood, of course, that that was purely experimental work. He understood, further, that certain restrictions would necessarily be imposed in respect of transmission work, and thought that the Post Office would have to be satisfied as to the nature of the transmission work that any student was desirous of doing. So far as he understood the matter, the whole object of the facilities granted by the Post Office was to give the students the opportunities they required to develop their knowledge, understanding, and learning of wireless telegraphy, which he conceived to be an extremely desirable thing from every point of view. That condition of things had existed prior to the war—but during the war, of course, this had to be stopped, and no experimental work at all was allowed by students—but now that the war was over there was every reason why it should be encouraged. He had not seen an announcement to the effect that the Post Office had invited students to use the Government installations for the purpose of acquiring knowledge of wireless telegraphy free of expenses. He had seen every announcement which had been made, and he felt quite certain that such an announcement had not been made, as it would be a practical impossibility for the Post Office to place their installations at the disposal of the students, as their stations had other work to do.

Referring to the relations which existed between the Post Office and the company, he said that shareholders were aware that unfortunately they had been obliged to bring actions against the Post Office by Petition of Right, but those actions had been brought as a result of their being unable to agree with the views of the Post Office as to what should be paid to the company. It was to be hoped, and he for one certainly believed, that the fact they had not been able to settle such questions as those upon which they had had to go into Court with the Post Office would not in any way influence the Government as to what should be given to the country, in the great need of the country, in respect of wireless telegraph stations. He refused to believe that the Marconi Company or the country was going to suffer because there had been a dis-

pute with regard to the settlement of accounts as between a Government Department and the company.

So far as the company was concerned, he had told them on previous occasions that there would have been no Petition of Right and there would have been no disagreement at all, if there had been an opportunity given to the company, even at a sacrifice, to come to an amicable settlement. He did not think it would be possible to erect such stations as were required for an efficient service—a commercial service between this country and the Dominions beyond the sea—without having recourse to the very valuable patents of the Marconi Company, to the great discoveries they had made in recent times, and to the very efficient system they were able to-day to offer. The only possible means of working stations without the Marconi Company would be by adopting an obsolete system, very imperfect, and wholly insufficient for the conduct of a commercial service, and he for one refused to believe that the Government would ever attempt to do anything of the kind, or that it would ever be recommended to them that they should do anything of the kind, or that the country would ever tolerate anything of the kind. He had no anxiety from that point of view.

THE NEW ISSUE OF CAPITAL.

With regard to the proposed issue of shares, he would tell them that the issue would be made somewhere about December 8 or 10. He could not, unfortunately, on that occasion tell them at what price the shares would be issued, nor could he tell them in what proportion they would be issued. Some shareholders had supposed, and he could quite understand their supposing, that the board had already made up their minds, and, as a matter of fact, they had very nearly done so. Nevertheless, they were not able on that occasion to say positively what they were going to do. He hoped it would be possible for the directors to make an announcement within the next day or so, and he could assure the shareholders that as soon as they were in a position to do so they would immediately issue a circular to the shareholders informing them exactly of what they proposed to do, and the issue of shares would be made a few days afterwards. He thought it would be better for the directors to make no announcement until they had quite made up their minds, because, even yet, it was just possible that there might be some change from what they were thinking of doing at the moment, and it would be very undesirable to commit themselves to any statement at that meeting, and still more undesirable to mislead the shareholders.

He had hoped that he would have been in a position to make an announcement on that occasion with regard to the terms of the issue, and possibly if the meeting had been held at

6 o'clock in the evening instead of at 12 noon, he would have been able to make a definite statement on that matter. He could assure them, however, that the shareholders could be quite satisfied that they would receive the most advantageous terms possible, and that the first and only thought of the board was for the shareholders and for the welfare of the company.

Replying to a further question, he said that he could not inform the meeting as to the amount of the claims made by the company against the Government for services during the period of the war. They asked for *Quantum meruit*. They did not put a figure upon

the claim, but in their view they had never received an offer which they thought they were reasonably entitled to expect. With regard to other claims, he had explained at a previous meeting that they were dependent very largely upon one question which was to be arbitrated upon—a claim for services rendered—and they had had to wait until Lord Moulton had fixed a date for that arbitration. The date had now been fixed, but until that matter was disposed of it was not easy to deal with other questions of claims, because they were largely dependent upon the award of that arbitration.

The resolution was unanimously approved, and the meeting terminated.

CIRCULAR TO SHAREHOLDERS.

The following circular to shareholders has been issued by the Directors of Marconi's Wireless Telegraph Company, Ltd.:—

Marconi House,
Strand, London, W.C.2,
3rd December, 1919.

Dear Sir (or Madam),

On the 13th ultimo at an Extraordinary General Meeting of the Company a Resolution was passed authorising the increase of the Company's capital by £1,500,000. The "Times" report of the proceedings of this meeting was duly forwarded to you.

On the 28th ultimo the Confirmatory Meeting was held and a copy of the "Times" report of the proceedings of that meeting is enclosed herewith.

At these meetings the Chairman informed you of the important and extensive developments of the Company's business and the necessity for the substantial increase of the Company's capital in order to provide for the commitments already entered into and to be ready to carry out the offer, if and when called upon to do so, which the Company has made to the Government to construct and organise a thorough and efficient Wireless Telegraph service between all distant parts of the Empire and the Mother Country.

In these circumstances and for the reason which has already been given at the Extraordinary General Meeting on the 13th November, it was regarded as inexpedient to distribute a cash bonus to the Shareholders, but a promise was made this should be compensated for by the terms of the issue of the new capital.

The Directors have pleasure in informing you that in fulfilment of this promise they have decided to issue the whole of the increased capital to shareholders only at £2 per share premium. This will entitle every shareholder, whether he holds Preference or Ordinary shares, to secure one new share at the price of £3 for every share he may hold

on the 4th December, 1919, when the register will be closed.

Letters of allotment and renunciation will be posted to both classes of shareholders and due provision will be made for the holders of Share Warrants upon fulfilment of the necessary formalities. The new shares will rank for dividends declared in respect of the period commencing 1st January, 1920, but in all other respects will rank *pari passu* with the existing 1,250,000 Ordinary shares of £1 each.

The transfer books will be closed from Thursday, 4th December, to Tuesday, 9th December, inclusive, for the preparation of allotment letters, which will be posted to the shareholders on or about the 8th instant.

It will be remembered that the Profit and Loss Account for the year ending 31st December, 1918, showed a net profit of £597,938 9s. od., which, together with the amount brought forward, left the sum of £974,698 14s. 8d. to the credit of Profit and Loss Account. After payment of dividends amounting to 25 per cent. for the year on the Ordinary shares and 22 per cent. upon the Preference shares and transferring £150,000 to General Reserve Account (making a total to the credit of General Reserve of £1,250,000), a balance of £463,786 14s. 8d. was carried forward to the current year's account.

With the considerable additional capital which this issue will provide, and having regard to the immense development of Wireless Telegraphic and Telephonic business throughout the world, the earning powers of the Company should be greatly enhanced. The Directors are confident that the profits of the current year will justify them in maintaining the rate of dividend, and there is every reason to hope that the increase in the capital of the Company should at least produce a proportionate increase of profits in future years.

I am, yours faithfully,

H. W. CORRY, Secretary.