

THE WIRELESS WORLD AND RADIO REVIEW

THE OFFICIAL ORGAN OF THE RADIO SOCIETY OF GREAT BRITAIN.

No. 234. (No. 19.
Vol. XIII.)

FEBRUARY 6th, 1924.

WEEKLY

EDITOR :
HUGH S. POCOCK.

RESEARCH EDITOR
PHILIP R. COURSEY, B.Sc., F.Inst.P., A.M.I.E.E.

ASSISTANT EDITOR :
F. H. HAYNES.

QUESTIONS AND ANSWERS DEPARTMENT :
Under the Supervision of W. JAMES.

CONTENTS

	PAGE
Resistance, Choke, or Transformer Low Frequency Couplings? By W. James - - - - -	580
A 180-220 metre Heterodyne Wavemeter. By Maurice Child - - - - -	584
A Four-Valve Dual Neutrodyne Receiver (<i>concluded</i>) By W. James - - - - -	587
The Myers Valve - - - - -	590
Wood's Metal. By James Strachan - - - - -	591
The Three-Electrode Valve. By W. Sydney Barrell - - - - -	592
Around the Wireless World - - - - -	595
Calculations of Capacity. By E. J. Hobbs - - - - -	598
With the Societies - - - - -	602
Correspondence - - - - -	604
Questions and Answers - - - - -	605

THE EDITOR will be glad to consider articles and illustrations dealing with subjects within the scope of the Journal. Illustrations should preferably be confined to photographs and rough drawings. The greatest care will be taken to return all illustrations and manuscripts not required for publication if these are accompanied by stamps to pay return postage. All manuscripts and illustrations are sent at the Author's risk and the Editor cannot accept responsibility for their safe custody or return. Contributions should be addressed to the Editor, "The Wireless World and Radio Review," 12 and 13, Henrietta Street, Strand, London, W.C.2.

SUBSCRIPTION RATES :

20s. per annum, post free. Single copies 4d. each or post free 5d. Registered at the G.P.O. for transmission by Magazine Post to Canada and Newfoundland.

As many of the circuits and apparatus described in these pages are covered by patents, readers are advised, before making use of them, to satisfy themselves that they would not be infringing patents.



EDITORIAL AND PUBLISHING
OFFICES :

12 and 13 Henrietta Street,
Strand, London, W.C.2.
Telephone : Gerrard 2807-9.

ADVERTISEMENT MANAGERS :

Bertram Day and Co., Ltd.,
9 & 10 Charing Cross, S.W.1
Telephone : Gerrard 8063-8.

RESISTANCE, CHOKE, OR TRANSFORMER LOW FREQUENCY COUPLINGS?

By W. JAMES.

HERE appears to be some confusion regarding the merits of the several methods of coupling valves for low frequency amplification. By low frequency is understood the band of frequencies set up by speech and music. The band may extend from about 200 to 10,000 cycles per second. The three methods, resistance (A), choke (B), and transformer (C), are shown in Fig. 1. The amplification A, obtainable with any of the couplings, is equal to the ratio of the voltage V_2 produced by the applied voltage V_1 ; that is $A = \frac{V_2}{V_1}$

The valve is a voltage operated device, and with any system of coupling, the aim is to cause the signal voltages V_1 to be repeated with the largest possible voltages V_2 .

Let us suppose the voltage amplification factor of the valve, $\mu = 10$, and that its normal alternating current internal resistance (anode to filament) under operating conditions $R_p = 40,000$ ohms, when the anode voltage is 60 volts.

RESISTANCE COUPLING.

Referring to Fig. 1A, the total anode circuit resistance is $R_p + R$, R_p being the valve anode filament resistance, and R the external resistance connected between the positive terminal of the anode battery and the anode. The current I_p flowing in the anode circuit as the result of applying a sine wave voltage, V_1 , to the grid circuit of the first valve, is equal to the voltage set up in the plate circuit divided by the total resistance, $R_p + R$. Now, a voltage of V_1 volts applied to the grid circuit acts like a voltage equal to $V_1 \times \mu$ in the plate circuit. Therefore we may write:

$$I_p = \frac{V_1 \times \mu}{R_p + R}$$

The current I_p is of course flowing through the external resistance and the valve in series; the voltage E_R set up across the external resistance is therefore equal to the

current multiplied by the external resistance, that is $I_p \times R = E_R$.

$$\text{But } I_p = \frac{V_1 \times \mu}{R_p + R}$$

Multiplying each side of the equation by R we obtain

$$I_p \times R = E_R = V_1 \times \mu \times \frac{R}{R_p + R}$$

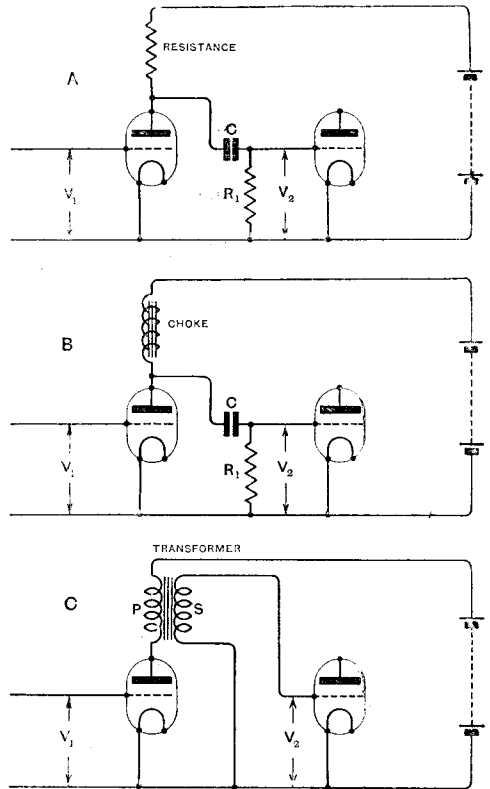

Fig. 1.

The voltage set up across the external resistance is communicated to the grid of the next valve by the condenser C, and as this condenser is designed so that there is no

appreciable fall in voltage across it, the whole of the voltage is applied to the grid; that is, we may say $E_R = V_2$. Then the voltage

$$\text{amplification } A = \frac{V_2}{V_1} = \mu \times \frac{R}{R_p + R}$$

That is, the actual voltage amplification obtained is equal to the voltage amplification of the valve (μ) multiplied by the value of the external resistance (R) divided by the total anode circuit resistance ($R_p + R$).

Without working out the formula, it will be clear that when the external resistance has the same value as the internal resistance of the valve, the total voltage set up in the anode circuit is equally divided between the valve and the resistance. The amplification obtained is exactly one half of that possible,

when an external resistance of 40,000 ohms is used.

From the equation

$$A = \mu \times \frac{R}{R_p + R}$$

we notice that the amplification is increased as the external resistance is increased, it being understood that the anode battery voltage is suitably adjusted. Let us find the amplification obtained for several values of external resistance.

(1) External resistance = 10,000 ohms.

$$A = \mu \times \frac{R}{R_p + R} = 10 \times \frac{10,000}{40,000 + 10,000} = 2.$$

(2) External resistance = 40,000 ohms.

$$A = 10 \times \frac{40,000}{40,000 + 40,000} = 5.$$

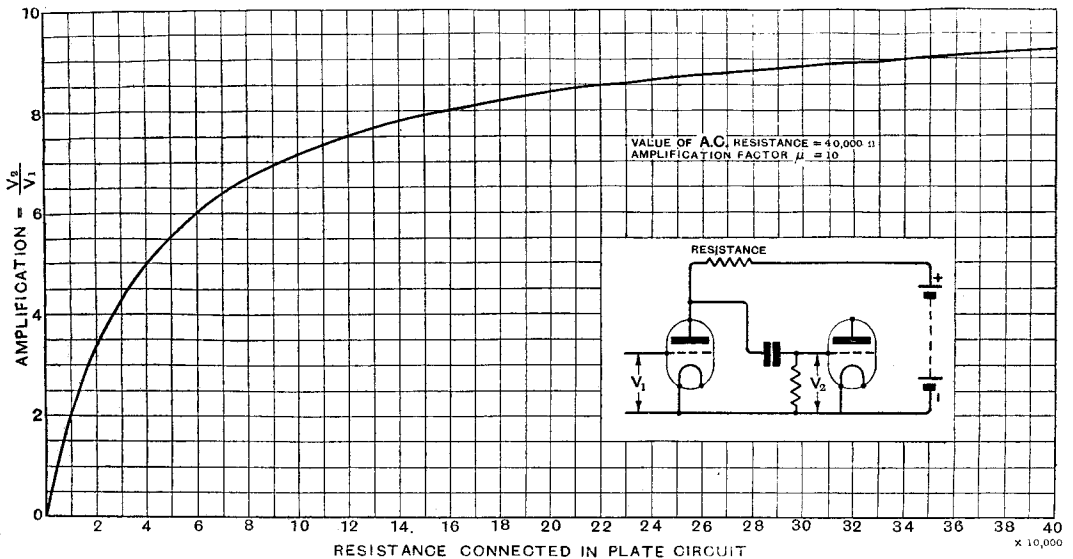

Fig. 2.

namely 5. Another point which should be borne in mind is that there is a fall in voltage across the resistance due to the normal anode current. The voltage at the anode of the valve is equal to the voltage of the anode battery, less the quantity—external resistance multiplied by the normal anode current.

If we assume that the normal anode current is 2 milliamperes, the battery should be increased by $\frac{2}{1,000} \times 40,000 = 80$ volts

(3) External resistance = 100,000 ohms.

$$A = 10 \times \frac{100,000}{40,000 + 100,000} = 7.1.$$

(4) External resistance = 400,000 ohms.

$$A = 10 \times \frac{400,000}{40,000 + 400,000} = 9.1.$$

By working out a number of other examples we may obtain sufficient points to plot a curve showing the relationship between the amplification obtained with various external

resistances. Referring to Fig. 2 the amplification obtained is marked against the vertical line, and the external resistances are marked on the horizontal line.

There are three important points to notice:—

(1) With resistance coupling it is impossible to obtain an amplification equal to the voltage amplification of the valve. If the external resistance were infinitely great, the actual amplification would equal the voltage amplification factor of the valve. When the external resistance is 10 times the valve resistance, the amplification obtained is only about 90 per cent. of the total possible.

(2) The larger the value of external resistance, the greater the amplification. From the curve it is seen that starting with a small value of external resistance, the amplification increases rapidly as the resistance is increased. With the larger values of external resistance, say above 100,000 ohms, the amplification only increases slowly.

(3) The voltage of the anode battery should be increased to compensate for the normal fall in voltage through the external resistance. The internal resistance of a valve depends on the value of grid and anode voltages. The internal resistance may be considerably increased by reducing the normal anode voltage, and, further, the valve will not be working according to the characteristics assumed above. If the resistance is increased, the amplification obtained will be less than that possible, because the ratio external to internal resistance is reduced.

From the point of view of straightening out the characteristic curve of the valve, an external resistance of about twice the internal resistance is satisfactory, provided the anode battery is suitably adjusted. In the case considered, the value of the resistance may be about 80,000 ohms. The anode battery should then have a voltage of 160 plus the normal anode voltage of the valve.

THE COUPLING CONDENSER AND GRID LEAK.

The voltage of the end of the resistance joined with the positive terminal of the anode battery, does not change when a signal is impressed on the grid of the valve, because the resistance of the battery is negligible. Therefore, so far as the signal voltages are concerned, that end of the resistance may be considered as having the

same voltage as the side of the filament of the valve to which the negative terminal of the anode battery is connected. If the grid of the second valve, Fig. 1A, was joined directly with the anode of the first valve, the grid would have the same potential as the normal voltage of the anode, which is so positive that the second valve could not function. The purpose of the coupling condenser, C is to break the path between anode and grid so far as the normal voltage of the anode is concerned, but yet to transmit without hindrance the voltages set up at the anode as the result of a signal.

When the grid is isolated by a condenser in this way, its normal potential varies according to the charge accumulated by the condenser plates joined to the grid, which is liable to become so negative that the anode current is reduced to zero. A resistance is therefore connected between the grid and the filament to provide a path for the escape of the grid charges. A usual value is one or two megohms.

The effective resistance between the grid and filament of the second valve consists of the leak resistance in parallel with the internal grid to filament resistance. The capacity between the grid and filament is considered negligible so far as low frequencies are concerned, and probably the effective resistance under normal operating conditions is of the order of 500,000 ohms. The grid condenser is in series with this resistance, therefore the voltage set up across the grid and filament as the result of a signal is equal to the total voltage set up across the external anode resistance, less the fall in voltage across the condenser. If a loss of voltage of 5 per cent. is permissible, the reactance of the condenser ought not to exceed about 26,000 ohms. For a mean speech frequency of 1,000, we find from the formula, reactance = $\frac{1}{2\pi fC}$, that a condenser of approximately 0.006 microfarads is suitable.

But here a question arises as to whether distortion is not likely to be produced on account of the percentage fall in voltage across the condenser being different for the different frequencies in the signal. For example, the reactance of the 0.006 μ F condenser to a 200 frequency signal is about 130,000 ohms. To a frequency of 5,000, the reactance is only 5,000 ohms.

These examples clearly show that all frequencies are not transmitted equally well. The lower frequencies set up relatively large voltages across the condenser, and if several stages of amplification are used, it should be expected that the resultant signal will differ from the original in that the higher frequencies have been amplified more than the lower frequencies. For this reason it is desirable to use larger coupling condensers. If a value of 0.05 microfarad is used, all frequencies should set up practically the same relative grid voltage, because the condenser reactance at 200 cycles is only about 16,000 ohms, which in comparison with the grid to filament resistance is quite negligible. But there is a limit to the capacity of the coupling condensers beyond which it is not advisable to go. The time constant of the grid circuit, equal to $R \times C$ seconds, should be comparable to the quantity $\frac{1}{f}$ seconds, where f is the frequency of an element of a speech signal. If the condenser capacity and the grid to filament resistance are both large, the time constant is of course large, and we would expect that in the event of a strong signal, the grid potential would

not fall to normal again before the arrival of the next signal. One cannot decrease the value of the grid leak beyond a certain value, because the anode resistance is shunted by the condenser and grid to filament resistance in series, and if the latter are low, the amplification will be a little reduced because of the lower effective resistance in the output circuit of the valve.

However, as a compromise, good values for the grid condenser and grid leak are 0.01 microfarad and 1 megohm.

In my opinion, from the point of view of securing perfectly distortionless amplification, it is advisable not to use grid condensers and leaks, but to connect batteries between the anode of the valve and the grid of the next. The positive terminal of the battery should be connected to the anode, and the negative terminal to the grid of the next valve, and adjustments of the voltage made to obtain the correct operating conditions. There are probably not many experimenters who will wish to go to the trouble of using these batteries to replace the coupling condensers and leak resistances.

(To be concluded.)

TRANSATLANTIC BROADCAST TESTS.

PRIZE AWARDS.

The enormous number of reports of successful reception of American broadcasting during the recent Transatlantic Broadcast Tests, induced us to offer prizes to those who had taken so much trouble in the interception of the American signals.

In our issue of December 12th we announced that we would award a first prize of £10 and a second prize of £5 to those listeners who could show the greatest originality in the design of their receiving apparatus. A very large number of descriptions of stations have as a result come to hand, and after careful consideration it has been decided to make the awards to the two listeners mentioned below.

Very many of the descriptions indicated the great care taken by experimenters in the design and construction of their sets. For instance, in many cases, special schemes had been introduced into the high frequency amplifying circuits to carefully control the extent of oscillation, both from the point of view of convenient manipulation and also for the purpose of minimising interference. In consequence, it is not possible to make an analysis of the various types of receivers which were successful in the reception of the American broadcasting, as there are so many varied arrangements. It is not even possible to draw conclusions on such simple matters as parallel or series condensers for

aerial tuning or to conclude that the tuned anode arrangement is in general more successful than say the high frequency intervalve transformer. A very small percentage of the successful sets employed dual amplification. Also, in nearly every case, high frequency amplification was employed, one high frequency valve being adopted, or two with switching.

We looked with interest to see what practical system was employed for the operation of more than one high frequency valve, and it is of interest to observe that no successful set of reliable design made use of two H.F. amplifiers in a manner requiring simultaneous tuning. Switching arrangements appear to be very popular.

We wish to thank the many who participated in the tests, and in particular those who so kindly submitted descriptions of their apparatus.

In such instances where the apparatus described is of particular merit, we will arrange to publish descriptions of the apparatus employed for transatlantic telephony reception, for this achievement can probably be regarded as the hall-mark of efficiency of an amateur set.

First Prize of £10—D. C. W. Howard, Esq., B.A., B.Sc., Sutton, Surrey.

Second Prize of £5—W. Hartley, Esq., Harrogate.

SHORT WAVE WAVEMETER.

A HETERODYNE OSCILLATOR FOR 180 TO 220 METRES.

Now that 200 metres is being adopted for amateur experimental working it becomes necessary to construct a wavemeter operating on this wavelength. Special signals are periodically transmitted from 6 XX with which this wavemeter may be calibrated.

By MAURICE CHILD.

WITH the increasing use by experimenters of wavelengths of the order of 180 to 220 metres, both for transmission and reception, it is of great assistance to quick and accurate work to be able to adjust the apparatus employed to the required wavelength, as much time is usually lost by the transmitting station getting in touch with the receiving station and *vice versa* unless this is done.

The following is a list of the parts required to make up a similar instrument to that about to be described.

- Polished wood box.
- Ebonite panel.
- 4 terminals.
- 4 valve brass sockets.
- 6-plate variable condenser (3 moving and 3 fixed plates).
- 0.01 μF fixed condenser.
- Ebonite former or tube $2\frac{1}{4}$ in. diameter.
- Copper foil for lining box.
- Copper foil for making up small fixed condenser.
- Telephone jack.
- Small switch for filament circuit of valve.
- Quantity of No. 26 S.W.G. D.S.C. copper wire.
- Anti-capacity extension handle for variable condenser.

The circuit arrangements will be seen from Fig. 1. In building up the instrument it is necessary to bear in mind that very small variations in the value of the inductances, variable condenser and small fixed condenser are sufficient to cause large errors in wave-range and therefore the reader is advised to

work to the dimensions given as closely as possible.

The first operation is to mark out the panel after having squared it up and well rubbed it down to remove any roughness on the surface.

The writer having the necessary workshop facilities built up his own variable condenser, thereby ensuring accurate fitting of the spindle in the bushes and eliminating "shake." Only the plates and spacing washers which are standard articles were bought, together with the usual knob, scale and ebonite back plate. If the experimenter is not able to construct his own variable condenser he should

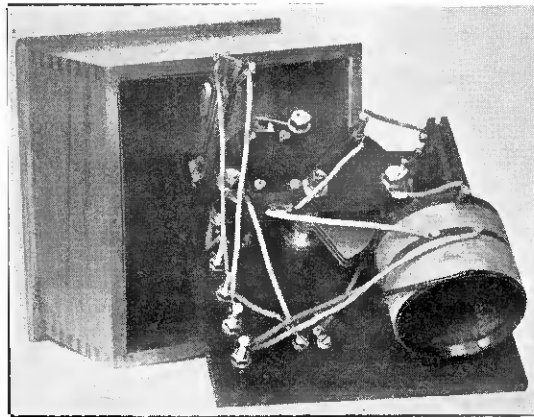

Interior of short wave heterodyne wavemeter. The interior of the case is lined with copper foil.

get one made, but it is advisable to avoid those types with top and bottom plates of metal as too much space will be taken up and additional capacity effects and losses may occur.

The inductances consist of two coils wound in the same direction and with $\frac{1}{4}$ in. spacing between them on the ebonite tube which can be fitted with a wooden plug at one end to which a small brass angle bracket can be screwed for fixing it to the panel. The grid circuit coil consists of 25 turns of No. 26 S.W.G. double silk covered copper wire and the plate circuit coil of 37 turns of the same wire. The turns should occupy a space of $\frac{1}{2}$ in. and $\frac{3}{4}$ in. respectively

and form single layer coils. The outer ends of the coils must go direct to the "grid and plate" valve sockets and the inner ends to the negative side of filament and positive of the H.T. battery respectively.

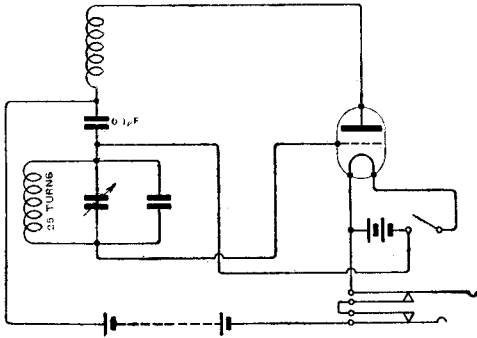

Circuit of wavemeter.

The telephone jack may be dispensed with if desired and two terminals employed instead, which must be "shorted" if tele-

phoned. mica dielectric separating them. Since mica varies considerably in thickness and few people have micrometer gauges, it is not necessary to follow exact dimensions here. This condenser is placed very conveniently on the back plate of the variable in order that small modifications in the size of the strips, thickness of mica, etc., can be made. In this way the wavelength range over which the instrument will tune can be adjusted.

Thus if the capacity of the fixed condenser is a trifle too large, the range may be 190 to 230. To remedy this either the middle strip can be pulled out a little or an extra thickness of mica can be put in on one side.

After each alteration, care must be taken to ensure that the top clamping plate is tightened before testing as the mechanical pressure materially affects the capacity. Two or three trials will probably be sufficient. For the purpose of these trials of waverange it will be found convenient to use an ordinary buzzer wavemeter placed within a foot or

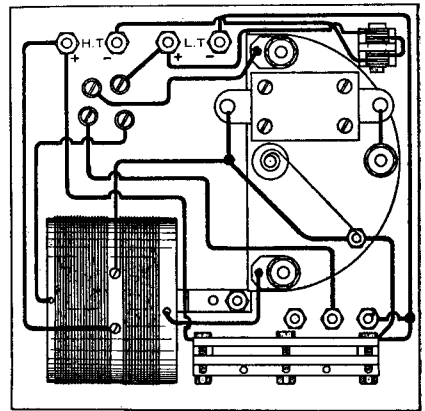
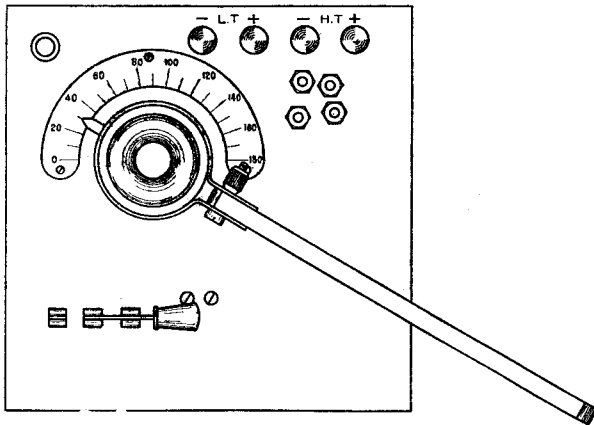

Top and underside drawing showing the layout of the components. An extension on the condenser knobs permits of critical adjustment and removes the hand from the circuit.

phones are not used. When telephones are used, as in the case of measuring the wavelength of a transmitter, they should preferably be of low resistance or an additional H.T. cell may be required. The H.T. battery recommended is of 15 volts. A 4-volt accumulator battery is employed without external resistance to light the filament.

A small fixed condenser is placed across the variable. This consists of two copper foil strips each side of a single strip with thin

two of the heterodyne, using telephones with the latter.

Usually one or two members of a local Radio Society have a buzzer wavemeter which they would be willing to lend for the purpose.

Before making the above trials and final calibration the containing box must have its sides and bottom lined with copper foil. This effectively screens the instrument from external capacities such as the H.T. and

L.T. batteries, the variation in position of which is found to slightly influence the wavelength calibration unless the above precaution is taken.

Sufficient energy gets in and out from the instrument through the ebonite top which is unscreened. It is for this reason that an extension handle is desirable for very fine measurements.

For the final accurate calibration, the experimenter should employ the special signals sent from time to time from the Radio Society of Great Britain's station on sufficient power to be heard all over the British Isles with a single valve receiver.

For the method of doing this, application should be made to the Secretary of the T. and R. Section of the Society, to which anyone may belong without formality beyond the payment of a nominal subscription.

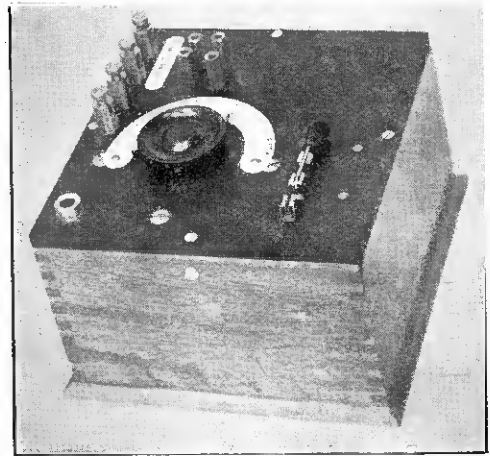

The finished wavemeter.

PATENT ABSTRACTS.

Crystal Detectors.

There are a number of types of crystal detector. With some it is an easy matter to obtain that delicate adjustment which is so necessary when detectors employing a form of cat-whisker are employed, and with others, adjustments are difficult and erratic.

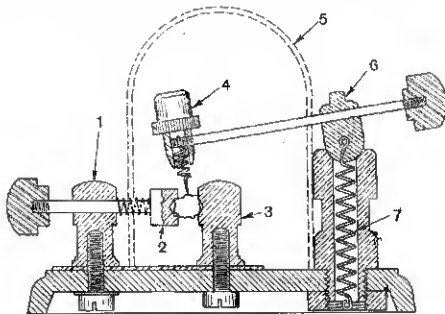

Fig. 1.

A form of crystal detector which, it is claimed, allows of easy adjustment,* is shown in Fig. 1. The crystal is held between the pillar (3) and the cup (2). The cup is carried by a rod which passes through the pillar (1), and may be rotated or moved endways. The contact wire is carried by a rod at (4), and the rod passes through the piece (6),

which is held by the spring (7). The contact wire may be moved up and down or sideways.

Variable Condensers.

An interesting sort of condenser, which may be of use in experimental work, is shown in principle in Fig. 2.*

One plate of the condenser consists of a wire or metal core (1). The dielectric (2) may consist of a braiding or sleeving, or any of the usual insulating materials. The second plate of the condenser consists of a metal wire or strip (3) wrapped over the dielectric (2), and the ends are held by the clips (4). The capacity may be varied by changing the number of turns in the helix (3) or by expanding or contracting the helix by

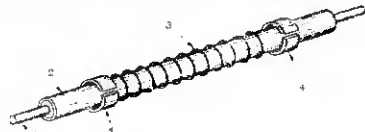

Fig. 2.

turning one of the clips (4). A condenser of this sort may be used as a neutralising condenser in a Neutrodyne receiver, and in any circuit where a small capacity is required, for example, a grid condenser. W.J.

*British Patent 207,649, by W. J. Brown, H. G. Bell, and Metropolitan Vickers, Ltd.

*British Patent 207,328, by W. C. J. Schlie.

A FOUR-VALVE DUAL NEUTRODYNE RECEIVER.

In the first portion of this article we described the principles underlying the construction of a Neutrodyne receiver. Below we continue with constructional and operating particulars.

By W. JAMES.

(Concluded from page 559 of previous issue.)

The ohmic resistance of the filament resistances to be used depends upon the type of valve it is proposed to employ. With valves taking 0.3 to 0.4 amperes, a total resistance of 7 or 8 ohms is satisfactory. When 60 milliamperes valves are to be used, a resistance of about 30 to 50 ohms is necessary. Special filament resistances of this value may be purchased; alternatively, those who may wish to try different types of valves are recommended to use the ordinary 5 or 6 ohm filament resistances, and to connect a resistance unit in series with the filament battery lead to the filaments. Suppose one wishes to use an "R" valve as the note magnifier, and 60 milliamperes valves in the remainder of the circuit. All the resistances may be alike—5 or 6 ohms—but a resistance unit may be connected between the terminal marked LT₁₂₃ and the filaments. Some resistance units are provided with an adjustment which may be made according to the voltage of the filament heating battery. If one wished to try ordinary "R" type valves throughout, it is only necessary to short circuit the resistance unit.

The reaction variometer consists of two circular pieces of grooved ebonite, one screwed to the back of the panel, and the other mounted on the end of the spindle which carries the knob. The formers are 2 ins. in diameter, with a groove $\frac{1}{2}$ in. deep and $\frac{1}{8}$ in. wide. Pin-type plug-in transformers with the pins removed were used in this receiver. One is fastened to the back of the panel with two countersunk 6 B.A. screws. The exact position is shown in Fig. 5. The other is screwed to a small piece of ebonite, $2\frac{1}{2}$ ins. long by $\frac{3}{8}$ ins. wide, so that one end projects. The end of the spindle is passed through this end and locked. Each former is wound with 50 turns of No. 30 D.S.C. and they are joined in series with the windings

in the same direction. The moving coil is arranged so that its surface only just clears the surface of the fixed coil.

THE BASEBOARD.

The baseboard is of wood, $23\frac{1}{4}$ ins. long, $7\frac{5}{8}$ ins. wide and $\frac{3}{8}$ in. thick. It carries the valve holders, fixed condensers, neutralising condensers, low frequency transformers, and the connection strip. The arrangement of the parts is clearly shown in Figs. 4, 5 and 6. The valve holders used are those sold by Burndepts, Ltd., and are very convenient for mounting on a board, because of the way the connections are brought out through the side of the holders. The fixed condensers have the following capacities:—15, 0.00025 μ F; 16, 0.002 μ F; 18, 0.005 μ F; 20, 0.0002 μ F; 22, 0.002 μ F. The grid leak is 2 megohms.

Condensers 17 and 19 are the neutralising condensers, shown in greater detail in Figs. 4 and 5. They are made up of an ebonite base $1\frac{1}{2}$ ins. square, on which is mounted a fixed brass plate about $\frac{3}{4}$ in. square, and a bracket carrying a circular brass disc about $\frac{5}{8}$ in. in diameter. The disc is soldered to the head of a 4 B.A. screw which is carried by the bracket. The end of the screw is slotted, and a nut is provided so that when the best capacity is experimentally determined, the moving plate may be secured.

The low frequency transformer (9) connected between the plate of the detector valve and the grid of the first valve (V₁) is one manufactured by W. G. Pye & Co. Type No. 1 is used, and the correct connections are I.P. to plate and O.S. to grid. This transformer was used because the makers claim that it has a flat frequency characteristic over the band of frequencies necessary for the successful transmission of music, and that the amplification when connected

to an average receiving valve is of the order of 25; both very desirable characteristics, to be sure. The transformer is certainly quite excellent.

The second low frequency transformer, 8 (a Marconi Scientific Instrument Co. transformer) has a low turn ratio, and is easily able to safely carry the heavier currents present in the second stage of note magnification.

A dry cell unit (21) consisting of two small dry cells is joined in the grid circuit of V_4 . The grid bias of 3 volts is satisfactory when an "R" type valve with 100 to 120 high-tension voltage is employed.

circuits, jacks, fixed condensers and low frequency transformers with those units removed. Any fairly heavy gauge tinned copper connecting wire such as No. 18 or No. 16 is satisfactory, and besides being easy to handle, looks pleasing. I found myself that heavy gauge square connecting wire is a little difficult to handle, more especially those connections terminating at jack contacts. Use the wiring diagram, Fig. 4.

When the wiring of the apparatus on the baseboard, and the jacks, resistances, and reaction variometer is accomplished, the condenser-transformer units may be assem-

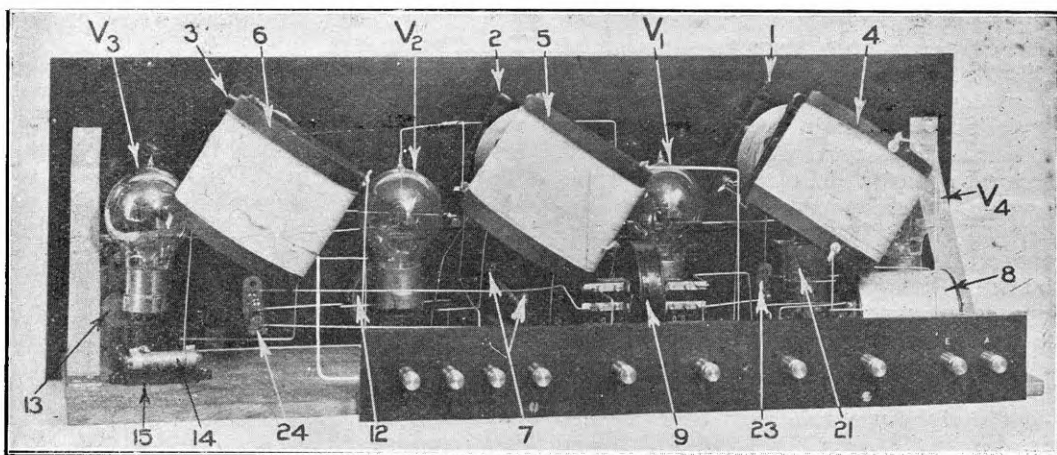

Fig. 2. Rear view of the receiver with the case removed. The parts are labelled as follows: tuning condensers 1, 2 and 3; high frequency transformers 4, 5 and 6; valve V_1 operates as a dual amplifier, V_2 as a high frequency amplifier, V_3 as detector and V_4 as a note magnifier; note magnifier transformer, 8; transformer in the dual circuit, 9; reaction variometer 7; detector valve jack 24; note magnifier jack 23; grid bias battery 21; grid condenser and leak 15 and 14.

SETTING UP AND WIRING.

I suggest the work is carried through in the following order: construct the high frequency transformers and fit them to the end plates of the variable condensers; construct the reaction variometer; if the components detailed above are to be used, mark out the panel and baseboard; fix all the components, using the lay-out of Figs. 4 and 5; alternatively, fasten the ebonite panel to the wooden baseboard with the brackets, arrange the components to their best advantage, mark their position, and then drill the panel and assemble. When satisfied with the fixing of all components, remove the condenser-transformer units. It is very much easier to wire the filament

and wired. There is a fair amount of room between the components, and wiring is a straightforward matter provided it is carried out without undue haste. Notice that the two neutralising condensers are connected between the tappings from the second and third high-frequency transformers and the grids of the first and second valves. No connection is made with the tapping of the first transformer.

OPERATION.

When the wiring is finished, insert all the valves and join up the filament heating battery according to the connections to the connection strip of Fig. 3. The valves V_1 , V_2 and V_3 , should light, and when the tele-

phone plug is pushed in the note magnifier jack, valve V_4 should light. If ordinary valves taking six volts are used throughout, terminals LT_{123} and LT_4 will both be joined to the positive terminal of the 6-volt accumulator. If special valves are to be used, connect the terminals accordingly. As a safety measure, it is well to connect a couple of dry cells to the high tension terminals and disconnect the filament battery to make sure there are no wrong connections between the filament circuit and the plate circuit. Then connect the proper batteries and the aerial and earth, and push the telephone plug into the detector valve jack. Leave the reaction variometer alone for the time being, and adjust the detector valve resistance just below the point where a slight hissing noise is heard.

Because all the coils and tuning condensers are alike, the second and third circuits should tune to the same wavelength when their condensers are set to the same settings. The first condenser setting will generally be a little less than that of the others. If possible, tune in a signal from a wavemeter; otherwise, search for a broadcast transmission by setting condensers 2 and 3 alike, and *slowly* turn the knob of condenser 1. Repeat the tuning in this way, advancing condensers 2 and 3, but one division of the dial at a time. When a signal is heard, carefully adjust all the condensers, the detector valve filament resistance, and the reaction variometer.

To adjust the neutralising condensers take the first valve out of its holder, place a piece of paper round one of the filament pins and put it back in the socket. The valve will not light now, of course. Carefully retune the first and second condensers, when the signal will in all probability be heard in the telephones. Now very carefully adjust the first neutralising condenser by bringing the moving plate closer to the fixed plate until nothing is heard in the receivers. If it is not possible to obtain an adjustment where no signal is heard, alter slightly the position of the wires connected with the first and second tuning circuits. When screwing the moving plate of the neutralising condenser towards the fixed plate it may be found there is a point where the signal is weakest, and any change in either direction of the movable plate strengthens the signal. Results will very likely be satisfactory even though a

silent point is not found. Carefully lock the movable plate by screwing up the nut.

Adjust the second neutralising condenser in the same way as the first, lighting the filament of V_1 and having the piece of paper round one of the filament legs of valve V_2 .

To properly adjust the neutralising condensers requires a little patience, and cannot be hurried. With improper adjustment, signals are either weaker than need be, or the circuits are liable to oscillate the same as in an ordinary receiver which is not provided with means for neutralising the back coupling (reaction) produced through the capacity coupling between plate and grid circuits.

Results are most satisfactory when a good outdoor aerial is used. At first tuning should not be hurriedly carried out, because the receiver is very selective, and I have found it easily possible to miss a station. Once the setting of the dials corresponding with the various wavelengths are recorded, tuning in is a pleasure, and may be undertaken by anyone, as it simply means setting three condenser dials. The receiver will tune over the broadcast band and up to about 600 metres.

Large capacity condensers, such as 0.5 microfarads, should, of course be connected between the positive connections from the high tension battery and the negative terminal.

A USEFUL TERMINAL.

A convenient terminal designed to facilitate the rapid change of connections and arranged to ensure reliable contact is shown below.

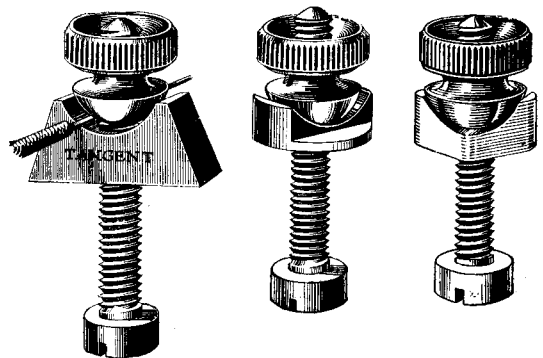

Courtesy : Geit & Co., Ltd.

New type of terminals.

The wires are held between two crescent-shaped faces, which offer the additional advantage that a number of wires can be reliably held.

THE MYERS VALVE.

WE have recently tested two types of the "Myers" valve submitted to us by Messrs. Cunningham & Morrison, of 49, Warwick Road, Earl's Court, one designed to work from two dry cells, and another known as the "Universal." This latter is an ordinary hot filament type. Both valves present the same outward appearance, and the first point to claim attention is the mounting, which is quite unique. The bulb is tubular in shape and is fitted with a cap at either end, through which the wires to the electrodes are taken, two being let through each end. This method of construction results in low capacity, but of course necessitates a special fitting. The drilling template supplied facilitates panel mounting however. Another point worthy of note, and applicable to both types of valve, is the extremely



A "Myers" valve.

rugged nature of construction. The electrodes are rigidly anchored together and are of such dimensions as to ensure freedom from microphonic noises, a point of extreme importance when dealing with multi-stage amplifiers. As to electrical behaviour, and dealing with the dry cell valve first, we find from a pamphlet issued that the normal filament current is 0.25 ampere, but the tube on which our tests were made gave no emission at this figure, and to obtain a saturation emission of 4 milliamps, the filament current had to be increased to 0.45 of an ampere. The relation

between filament current voltage and emission is shown in Fig. 1B. Fig. 1A gives the anode current grid volts characteristic, from which it will be seen that the tube has a magnification factor of 10 and a resistance

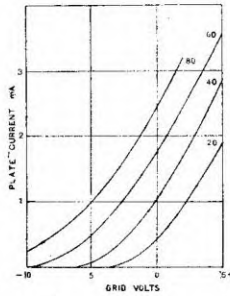

Fig. 1A.

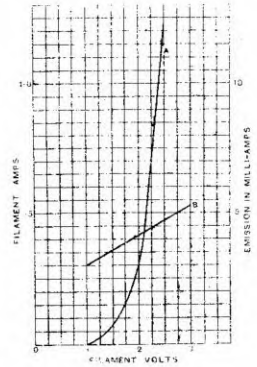

Fig. 1B.

of 30,000 ohms. It will be noted that the characteristics are straight for an appreciable range, and thus the valve should function well as a low frequency amplifier.

As regards the "Universal," a similar discrepancy appears with regard to filament volts and amps. This is shown in Fig. 2B. Fig. 2A gives the anode current grid volt characteristics of this valve, which shows a magnification factor of 7 and a resistance of 27,000 ohms. Here again the characteristics, particularly the 100 and 120 volt curves, are straight over a very extended range.

Correctly adjusted, the valve should easily fulfil the claim of rendering perfect amplification

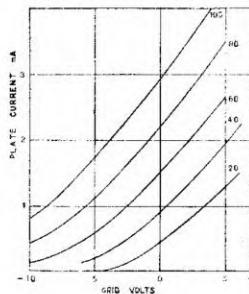

Fig. 2A.

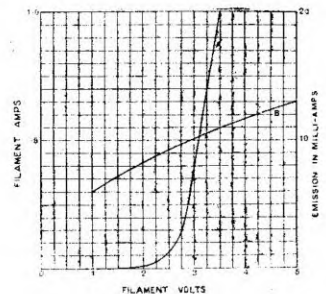

Fig. 2B.

WOOD'S METAL AND OTHER FUSIBLE ALLOYS.

By JAMES STRACHAN, F.Inst.P.

WOOD'S fusible alloy was invented more than fifty years ago for the purpose apparently of making impressions of combustible objects for reproducing electro-plated replicas of the latter. Owing to the considerable contraction that takes place in this metal while cooling from the liquid state, it did prove perfectly satisfactory for this purpose, and for many years, apart from a few laboratory uses, it remained, with similar alloys, a scientific curiosity.

Its chief commercial application was the manufacture in Germany of trick tea-spoons for the conjuror and the practical joker, until the advent of wireless created a fairly large demand for fusible alloys for the purpose of fixing the universal crystal in its cup.

Wood's original patent appears to have shown rather a different composition from that generally attributed to this inventor, but it should be noted that many of the fusible alloys now on the market do not melt at the low temperature generally assigned to "Wood's metal" (150°F. or 65° C.).

Fusible alloys are made by melting and stirring together, lead, tin, bismuth and cadmium metals. The melting points of these metals are :

Lead	327° C.
Tin	232° C.
Bismuth	269° C.
Cadmium	320° C.

but mixed in almost any proportions, the alloy produced has a much lower melting point than that of any one of the ingredients.

The following table shows the composition of some fusible alloys and their melting points.

Name of Alloy	Containing parts by weight of				Melting Point ° C.
	Lead	Tin	Bismuth	Cadmium	
Wood's ..	2	1	4	1	65°
Lipowitz's ..	2·7	1·3	5	1	65°
Lichtenberg's	3	2	5	None	91°
Arce't's ..	1	1	2	None	94°
Rose's ..	2·8	2·4	5	None	95°
Newton's ..	3½	1½	5	None	94·5°
Eutectic of Lead, Tin and Bismuth	2	1	3½	None	96°

In preparing these alloys the lead should be melted first, the tin added in thin rods or foil, then the bismuth broken into grains and finally the cadmium. It should be noted that fusible alloys containing cadmium are very easily oxidised, particularly in a damp atmosphere. Intermediate melting points between 65° C. and 90° C. may be obtained by reducing the proportion of cadmium. Arce't's alloy without cadmium is quite suitable for setting crystals, as any alloy used for this purpose should melt below the boiling point of water and not oxidise rapidly. As all alloys containing bismuth contract considerably just before solidification, the crystal should be warmed to the same temperature as the melted alloy and inserted just as the latter is on the point of solidification. This ensures the best contact.

For other purposes the ternary eutectic is a good basis to work upon. This melts at 96° C. and by gradually reducing the bismuth any melting point up to 200° C. may be obtained in the resulting alloy.

All these fusible alloys may be made into pasty amalgams by the addition of from two to three times their own weight of mercury. While an amalgam undoubtedly makes a good contact with the crystal, I do not advise its use as mercury gives off vapour at ordinary temperatures which is not only poisonous, but corrodes many of the metals used in wireless apparatus—particularly aluminium. A trace of mercury on aluminium acts as a catalyst and does not rest until the whole metal is completely oxidised to alumina.

A bismuth solder made from lead two parts, tin one part, and bismuth two parts (by weight) melts not very much above the boiling point of water, viz., about 112° C. and makes a useful metal for making connections behind ebonite. The melting point and the strength of the solder are increased by reducing the bismuth. With the lower melting point solders of this kind, connections may be made very neatly without the use of a soldering-bolt, by the use of a very tiny spirit-lamp. The surfaces to be soldered should be well tinned before mounting and the usual flux employed.

THE THREE-ELECTRODE VALVE.

This article deals with the theory of the three-electrode valve and in particular with the function of the grid and valve characteristics.

By W. SYDNEY BARRELL.

GENERAL CONSIDERATIONS

THE general principles underlying the action of the two-electrode valve already outlined* apply equally to the three-electrode type which will now be considered.

In this latter type a third or control electrode has been added which is usually placed in the path of the electron stream between the filament and the anode. This additional electrode is called the grid, possibly by reason of its original shape, and may be of various forms even to a plate situated on the side of the filament opposite to that of the anode. Generally it will be found to take the form of a spiral or mesh placed between, but insulated from, the filament and the anode, and in these notes this type of construction will be mainly discussed.

In its original form the three-electrode valve was used solely as a detector of radio frequency oscillations, but to-day its use is by no means limited to this particular field.

Neglecting for the moment the presence of the grid, we already know, from our consideration of the two-electrode valve, that if the filament is raised to a sufficiently high temperature, by passing a current through it, electrons will be forced out from its surface in a continuous stream. We further know that the current through the valve is a function of the number of electrons reaching the anode, and will depend upon the filament temperature (filament current) and the anode voltage with respect to the filament. It should, perhaps, be reiterated here that in valve working the end of the filament connected to the negative terminal of the low tension battery is always regarded as the point of zero potential, and all potentials, positive or negative, are measured with respect to this point.

The object of the grid is to control the flow of electrons from the filament to the

plate, and for any valve with given filament current and anode voltage the potential of the grid will determine the anode current. In a general and simple way this can be demonstrated with the help of Fig. 1, as follows:—

Case 1.

Referring now to Fig. 1, and with the filament operating at normal brilliancy, suppose the grid to be connected directly to the negative end of the filament D so that

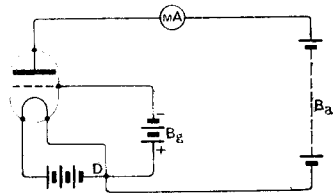

Fig. 1.

the two are at the same potential, then under these conditions a certain current will flow in the anode circuit, as indicated by the milliammeter M.A. This current will, however, be limited by the space charge, that is to say, by the electric charge due to the cloud of electrons around the filament.

Case 2.

Now let the grid be maintained at a positive potential with respect to the filament, as may be done by connecting the small battery B_g with its + terminal to the grid and its - terminal to the filament. The milliammeter M.A. will now show a higher reading than in Case 1, proving that the current flowing in the anode circuit is now greater than when the grid was at zero potential.

Case 3.

Now reverse the connections of the battery B_g so that the - terminal is connected to the grid and the + terminal to the filament. This will give the grid a potential negative

**Wireless World and Radio Review*, No. 233, p. 565.

with respect to the filament, and we shall now find that the anode current has been reduced below that which obtained in Case 1.

From the foregoing we prove in a rough way that, providing the filament current and anode volts remain constant, the rate of flow of the electrons from the filament to the anode is controlled by the potential of the grid with respect to the filament. This is most important, and is the principal point underlying three-electrode valve working.

The question may be asked: What happens if the grid, instead of being either connected to the filament or battery B_g , is left disconnected? The answer is that it depends entirely on the design of the grid mesh. It may, for example, if the construction is suitable, stop entirely the current to the anode. On the other hand, the anode current may be but little changed from the case when the grid was directly connected to the filament.

FUNCTION OF THE GRID.

The three-electrode valve may be said to function by reason of the effect of the grid on the potential distribution between the filament and the plate. Let us consider this a little closer. Referring again to Fig. 1, the battery B_a will maintain the anode at any desired potential positive with respect to the filament, while the grid can be given a potential, either + or -, by means of the battery B_g . Now, supposing the grid is connected directly to the negative end of the filament at D, its potential is now zero, but some of the electrons emitted by the filament are attracted to the anode by those lines of force which are able to act through the openings in the grid mesh. Now this "leakage or stray field," as it is called, is proportional to the anode voltage and the relative shape and disposition of the anode and grid, the truth of this latter statement being somewhat roughly demonstrated diagrammatically in Fig. 2.

Now, supposing this potential to be negative, then we have the potential of the anode tending to draw the electrons through the spaces in the grid to the anode A, whereas the negative potential on the grid is tending to push them back to the filament, and if the potential of the grid is sufficiently increased in a negative direction a value will be reached when all the electrons are returned to the filament and the current to the plate

is zero; this will happen when the grid potential is equal to, but of opposite sign to the stray field, so that whether or not current flows through the valve will depend upon the relative values of the leakage field and the potential of the grid.

Quantitatively, this leakage field which passes through the grid can be shown to be equal to the anode volts divided by a factor

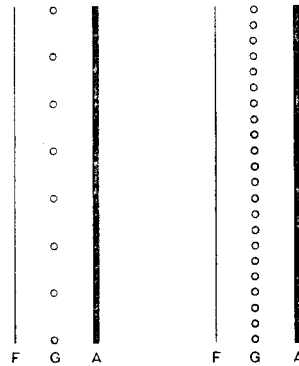

Fig 2.

K , which is always greater than 1, its exact value depending upon the mechanical dimensions of the valve. We shall have occasion to refer to this constant K later on. Another way of considering the action of the grid is to think of it as modifying the effect of the space charge. When a positive potential is applied to the grid it partly neutralises the space charge, and hence allows a greater number of electrons to pass to the anode, with consequent increase of current through the valve. The application of a negative charge on the grid will therefore produce the reverse effect, and by assisting the space charge the anode current will be reduced.

VALVE CHARACTERISTICS.

Having then in a general way demonstrated the controlling action of the grid, we shall now pursue this study somewhat deeper.

We have in the three-electrode valve three factors capable of independent variation, these being—

- (1) The filament temperature.
- (2) The anode voltage.
- (3) The grid voltage.

and we can take all sorts of measurements to indicate the variation which occurs in the anode current when any two of the above

factors are kept constant, the third only being altered.

THE EFFECT OF GRID ON ANODE CURRENT.

The first experiment is to show how the anode current varies with change of grid potential, the temperature of the filament (*i.e.*, filament current) and the anode voltage remaining unaltered. The circuit required is given in Fig. 3, which is at once seen to be merely an elaboration of Fig. 1. The anode A is connected through a milliammeter m.A. to the + side of the anode battery B, the negative side of which is connected to the end of the filament which is joined to the - terminal of the filament battery.

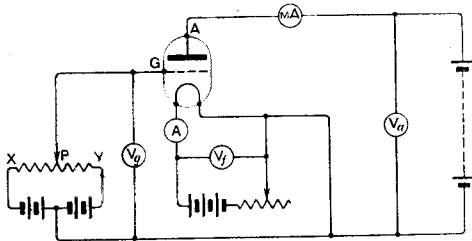

Fig. 3.

The grid G is connected through the potentiometer P, the object of which is to enable the grid potential to be varied as and how desired. As arranged in the figure, a maximum negative potential is applied when the slider is at X and a maximum positive when the slider is in the position denoted by Y. Between these limits any desired potential + or - can be applied to the grid, its value being shown by the voltmeter V_g. Now the actual value of anode current which will flow for different applied grid potentials will be dependent on several factors. Chief among these may be mentioned:—

- (a) Size of mesh, that is whether the mesh is open or close.
- (b) Diameter of grid wire.
- (c) Distance filament to grid and grid to anode.
- (d) Anode voltage.
- (e) Filament current.

In order therefore to state a definite case, we shall make use of an "R" valve, and shall adjust the voltage across the filament to 4 volts and 50 volts on the anode.

For each setting of the grid potential we get a certain reading of anode current and in the case under review the following were actually obtained:—

Grid volts as measured by V _g .	Anode current as measured by M.A.
-8	0
-6	0.04
-4	0.16
-2	0.4
0	0.8
+2	1.27
4	1.76
6	2.24
8	2.74
10	3.24
12	3.7
14	4.05
16	4.3
18	4.42
20	4.51
22	4.57
24	4.6
26	4.6

Using squared paper and plotting grid volts along the horizontal axis and anode current along the vertical axis, we get the curve of Fig. 4.

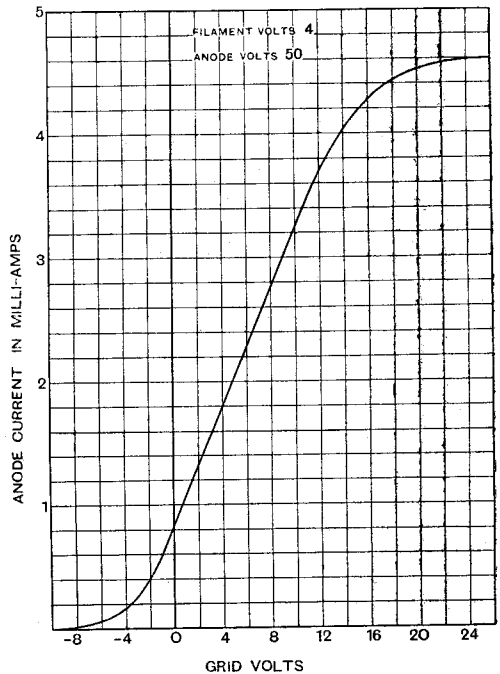
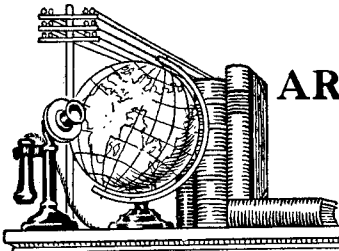

Fig. 4.

This curve is very similar in shape to that of the two-electrode valve obtained by plotting anode current against anode voltage, but in the present case we have plotted the current in one circuit, *i.e.*, the anode circuit, against the voltage impressed across a second circuit, namely, the grid.

(To be continued.)



AROUND THE WIRELESS WORLD

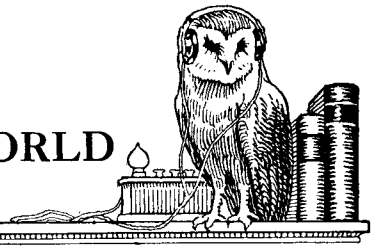

Loughborough residents are advocating the establishment of a relay broadcasting station in the district.

* * * *

A Delhi message states that the Government has definitely decided to entrust India's link in the Imperial wireless chain to private enterprise.

* * * *

Following a recent storm, a section of the Southern Pacific Railway, U.S.A., was kept in operation by means of wireless communications.

* * * *

Speech and music from 2 LO have been picked up by the R.A.F. station at Baghdad.

* * * *

Difficulty is being experienced in choosing acceptable broadcast programmes for the Women's Hour. The trouble will be overcome, we believe, only when means are devised to enable the fair listeners to answer back.

* * * *

"Personally, I always use resistance capacity magnification."—Captain P. P. Eckersley.

* * * *

"I would rather give a patient a radio set than a whole handful of pills."—Dr. Foley of Minneapolis.

* * * *

A Talk on Two-Way Communication.

Mr. J. A. Partridge, the first British amateur to establish two-way communication with an American amateur, will give a talk on "Working with America" at the headquarters of the Wimbledon Radio Society, on Friday, February 8th, at 8 p.m. A limited number of tickets will be available to the public, and application should be made at once to the Hon. Sec., Mr. C. G. Stokes, 6, Worple Avenue, Wimbledon, S.W.19.

Unemployed Wireless Operators.

At the present time 1,800 persons holding the P.M.G.'s First Class Certificate in Wireless Telegraphy are unemployed. In view of this fact it behoves would-be candidates, parents and guardians, to examine very carefully the prospectuses of the various wireless colleges, and to ascertain for themselves what prospects are offered to students when their training is completed.

This timely caution is issued by the Association of Wireless and Cable Telegraphists, of Lennox House, Norfolk Street, Strand, W.C.2., from whom up-to-date information concerning all aspects of the marine wireless profession can be obtained.

1 MT's Handsome Record.

To an already imposing list of English amateurs with whom he has worked, Italian 1 MT (Signor

Guilio Salom) of Venice, has now added 5 MO and 2 FN. 5 MO, the station of Mr. W. G. Dixon, is situated at Newcastle-on-Tyne, while 2 FN, at Ruddington, Notts, is owned by Mr. L. M. Baker.

Irish Broadcasting.

In spite of broadcasting delays in the Irish Free State, the Radio Association of Ireland is looking ahead in a very hopeful and practical manner. At the annual meeting of the Association, held on January 15th, the members expressed the unanimous opinion that any broadcasting station which may be set up in the Free State should be so arranged with regard to power, wavelength and locality as not to interfere with the reception of any broadcasting stations in other countries. Surely a very gracious compliment to the B.B.C.!

Liverpool's Relay Broadcasting Station.

A petition to H.M. Postmaster-General, urging the establishment of a relay broadcasting station in the Liverpool district is now in course of preparation. The petition, we understand, may be signed at most of the wireless depots within a radius of 15 miles of the city. Copies for signature may be obtained from Mr. W. C. Barraclough, 61, Bridge Street, Manchester, or from the Editor of the *Liverpool Courier*.

Argentine-Europe Wireless Service.

The new wireless station at Monte Grande, for the purpose of placing the Argentine in direct wireless communication with North America, Europe and the Far East, was formally opened on Friday, January 25th, when an inaugural message was sent to King George V by the President of the Argentine.

A New Appointment.

Lieut.-Col. Norman Harrison, C.M.G., D.S.O., M.I.E.E., who retired last November from the under-Secretaryship, Department of Posts and Telegraphs of the Union of South Africa, has joined the Directorate of the Western Electric Co., Ltd., and will shortly return to South Africa to take up residence there in the interests of the Company.

A Puzzling Transmission.

A fine French concert on Sunday, January 13th, between 5 and 6 p.m., was received by Mr. W. T. Tucker, of Loughborough, on a wavelength slightly below that of Bournemouth. Our correspondent is firmly convinced that he was not listening to a harmonic from one of the high power stations. Did any other reader intercept this transmission?

What can be done in Czecho-Slovakia.

Almost all the B.B.C. stations can be heard in Czecho-Slovakia on a loud speaker, according to a report which we have received from an enthusiastic amateur residing near Prague. **2 LO** and **2 ZY** are heard best, but our correspondent adds that, at the moment of writing, speech from the Glasgow station could be heard in the headphones lying on the table.

The receiver at present consists of a detector with two stages of low frequency amplification, though the British stations were originally heard with a galenite crystal and one stage of L.F. No doubt much of our correspondent's success is attributable to the size of his aerial, which measures 325 feet in length, and is 60 feet high.

"Music from the Skies."

This title adorns the cover of an extremely attractive brochure which has just been issued by Messrs. the Marconi Scientific Instrument Co., Ltd. A number of handsome illustrations of the Company's well-known broadcasting receivers is included, accompanied by interesting letterpress.

for the reception of the various classes of vocal, instrumental and orchestral selections.

We understand that "Sparta" loud speakers are being demonstrated at Selfridges, Harrods, Gamage and at the Company's London Depot, 58, High Street, W.C.2.

Calibration Signals.

6 XX, the station of the Radio Society of Great Britain at Hammersmith, will transmit calibration signals (V's) beginning after midnight (G.M.T.) on Wednesday, February 6th, and alternate nights until February 14th, as follows: 2400 to 0005, on about 220 metres; 0010 to 0015, on about 180 metres; 0020 to 0025, on about 150 metres; 0030 to 0035, on about 120 metres; at 0040, a message.

At about 0015 a series of code words will be sent on about 180 metres, with gradually diminishing antenna current. A record of the antenna current corresponding to each code word will be kept, and published later. Everyone who notes down the last code word he is able to receive will thereby obtain an indication of the sensitiveness of his apparatus, and of the effect of his geographical position.



Our photograph shows the company assembled at the annual dinner of the Radio Society of Great Britain, held at the Waldorf Hotel, London, on Wednesday, January 23rd.

Greenwich Time Signals Broadcast.

Beginning from Tuesday, February 4th, a system of automatic time signals has been inaugurated, the signals being transmitted by landline from Greenwich to **2 LO**, and thence broadcast in the usual manner. The times of transmission are at present 3.30 p.m. and 9.30 p.m. on weekdays and 10 p.m. on Sundays. Clock beats begin at 55 seconds and finish on the minute.

A Loud Speaker Development.

The latest arrival in the ranks of loud speakers is the "Sparta," manufactured by that well-known firm, Messrs. Fuller's United Electric Works, Ltd. Two models are being marketed, and Type B embodies a unique feature in the form of an additional control, permitting six different adjustments

Radio Society of Great Britain.

An informal meeting of the Society will be held on Wednesday, February 13th, at 6 p.m., at the Institution of Electrical Engineers, Savoy Place, W.C.2. A discussion will be opened by Mr. J. H. Reeves, M.A., on "Fine Wire Coils as an Aid to Distortionless Reception."

Annual Conference of Affiliated Societies.

It has been proposed to hold the postponed Conference of Affiliated Societies in the week beginning February 25th next. To some members Saturday, March 1st, would be convenient, but it is believed that others may prefer Wednesday, February 27th. Will Secretaries of Societies or prospective Delegates kindly advise the Hon. Secretary at 53, Victoria Street of their preference before February 8th.

Calls Heard.

Brixton Hill, S.W.2.
 2 BZ, 2 FJ, 2 KF, 2 KV, 2 NF, 2 NQ, 2 OB, 2 OK, 2 OM, 2 SO,
 2 SZ, 2 TI, 2 TQ, 2 VS, 2 XZ, 2 ZB, 5 AC, 5 DT, 5 FH, 5 FL, 5 HI,
 5 MT, 5 MY, 5 PC, 6 IM, 6 IO, 6 ON, 6 PS, 8 WV. (x valve,
 Flewelling.) (R. E. Broomfield.)
 Norwich.
 2 AO, 2 AT, 2 BO, 2 BZ, 2 CW, 2 FL, 2 IN, 2 IZ, 2 KW, 2 OG,
 2 WK, 5 AC, 5 FO, 5 MO, 5 OK, 6 NI, 6 NO, 6 XX, 8 AEI, 8 AE,
 8 ARA, 8 CB, 8 CH, 8 CJ, 8 CK, 8 CP, 8 CT, 8 DD, 8 DD, 8 DK,
 8 DX, 8 EB, 8 ET, 8 ZZ, 0 YS, PA9. (H. J. Jarrold.)

Bath.
 2 AW, 2 BW, 2 CW, 2 DF, 2 FL, 2 GV, 2 HQ, 2 IL, 2 IJ, 2 KP,
 2 LF, 2 LM, 2 MG, 2 NA, 2 NL, 2 NM, 2 NS, 2 OM, 2 PB, 2 RB,
 2 SR, 2 SZ, 2 WU, 2 YT, 2 ZG, 5 CC, 5 DO, 5 FS, 5 HW, 5 KC,
 5 KM, 5 KO, 5 RO, 6 IM, 6 RY, 8 AQ, QAJ, BXH. (1, 2 or 3 valves.)
 (G. W. Salt.)

Ilford, Essex.
 2 FK, 2 HX, 2 JX, 2 KT, 2 OM, 2 ON, 2 PU, 2 PX, 2 QQ, 2 XR,
 2 XX, 5 LN, 5 PU, 5 PZ, 5 TR, 5 UL, 5 VR, 5 WR, 6 IM. (Crystal
 only.) (E. C. H. Smith.)

Edgbaston, Birmingham.
 2 DU, 2 KF, 2 NU, 2 RD, 2 TN, 2 TV, 2 VB, 2 WB, 2 WN, 2 YS,
 2 YV, 2 YX, 5 EH, 5 KB, 5 KD, 5 KY, 5 LK, 5 NU, 5 UW, 5 XL,
 5 YS, 6 HU. (G. Curtis, 5 VB.)

Liverpool.
 2 BT, 2 FC, 2 FL, 2 FN, 2 FU, 2 FZ, 2 IJ, 2 IL, 2 IN, 2 JF, 2 JP,
 2 KF, 2 KS, 2 KU, 2 KW, 2 MY, 2 NF, 2 OA, 2 OM, 2 ON, 2 PC,
 2 PP, 2 RM, 2 SF, 2 TG, 2 TB, 2 TC, 2 TR, 2 VF, 2 VK, 2 VN,
 2 VS, 2 WH, 2 WJ, 2 WK, 2 WY, 2 ZK, 2 ZS, 2 ZU, 5 AJ, 5 AV,
 5 AY, 5 AX, 5 BF, 5 CE, 5 CX, 5 DB, 5 DC, 5 DN, 5 FD, 5 GB,
 5 GR, 5 HA, 5 HC, 5 HE, 5 HT, 5 ID, 5 IK, 5 IZ, 5 KC, 5 KO,
 5 KP, 5 LC, 5 LH, 5 LT, 5 ML, 5 MO, 5 NA, 5 NN, 5 OA, 5 OT,
 5 PK, 5 RP, 5 RH, 5 SI, 5 SJ, 5 US, 5 UO, 5 VF, 5 VJ, 5 XJ, 5 ZW,
 6 AK, 6 AN, 6 BW, 6 DJ, 6 EA, 6 HS, 6 IC, 6 IL, 6 KK, 6 NL,
 6 NI, 6 OM, 6 OP, 6 PL, 6 RF, 6 RW, 6 RY, 6 UC, 8 AB, 8 AQ,
 8 AS, 8 AU, 8 AW, 8 BF, 8 BM, 8 BV, 8 CJ, 8 CS, 8 CT, 8 CZ,
 8 DA, 8 DY, 8 EB, 8 FN, 8 NY, 0 OX, 0 XP. (0-v-1.)
 (J. W. Hefferman.)

Chislehurst, Kent.
 2 BZ, 2 FP, 2 FG, 2 JM, 2 KT, 2 KV, 2 MC, 2 MK, 2 OD, 2 OM,
 2 PX, 2 QS, 2 SN, 2 SX, 2 SZ, 2 TO, 2 VS, 2 WJ, 2 XP, 2 XR,
 2 XZ, 2 IV(?), 5 AC, 5 AD, 5 BT, 5 CP, 5 DT, 5 HI, 5 IO, 5 IS,
 5 JW, 5 JT, 5 LP, 5 OY, 5 OK, 5 OP, 5 PU, 5 PT, 5 SU, 5 UO, 5 VR,
 5 WN, 5 XN, 6 FH, 6 IM, 6 IN, 6 NH, 6 RJ. (0-v-2.)
 (Eric Cuddon.)

Chew Magna, nr. Bristol.
 2 AB, 2 AS, 2 AZ, 2 BO, 2 CW, 2 FL, 2 FS, 2 GA, 2 GB, 2 GG,
 2 HG, 2 HQ, 2 IL, 2 IS, 2 KF, 2 KO, 2 KP, 2 KV, 2 LF, 2 MP,
 2 NG, 2 NS, 2 OL, 2 OM, 2 OP, 2 PL, 2 PM, 2 PO, 2 RL, 2 RM,
 2 RO, 2 RY, 2 SB, 2 SL, 2 SS, 2 UF, (spk.), 2 UU, 2 UV, 2 WA,
 2 WD, 2 WO, 2 WS, 2 WU, 2 YS, 2 ZG, 5 AB, 5 AD, 5 BA, 5 BO,
 5 DB, 5 DO, 5 FR, 5 FS, 5 FV, 5 GZ, 5 HM, 5 KM, 5 KO, 5 LP,
 5 MM, 5 NR, 5 OP, 5 PU, 5 RO, 5 SR, 5 TO, 5 TT, 6 TH. (1, 2 or
 3 valves.) (G. W. Tripp.)

Ashford, Middlesex.
 2 AQ, 2 AN, 2 AJ, 2 AAH, 2 BZ, 2 BV, 2 BT, 2 CQ, 2 FL, 2 EP,
 2 HF, 2 IB, 2 JP, 2 JF, 2 JO, 2 JZ, 2 KA, 2 LW, 2 LF, 2 MF, 2 MO,
 2 NA, 2 NM, 2 QH, 2 RS, 2 SX, 2 SG, 2 SZ, 2 TA, 2 TB, 2 TP,
 2 TU, 2 TE, 2 UJ, 2 VJ, 2 VW, 2 WA, 2 WJ, 2 WK, 2 WR, 2 WS,
 2 XT, 2 YB, 2 UC, 5 US, 5 VR, 5 VM, 5 WA, 5 WR, 5 WN, 5 CS,
 5 CG, 5 DN, 5 DB, 5 DK, 5 EW, 5 GW, 5 HW, 5 HP, 5 HA, 5 IS,
 5 IC, 5 JW, 5 KO, 5 KZ, 5 MA, 5 MO, 5 NO, 5 OK, 5 ON, 5 OY,
 5 OP, 5 PS, 5 PU, 5 PD, 5 QV, 6 DW, 6 FQ, 6 EA, 6 NF, 6 NI,
 6 NE, 6 RY, (QRA?), 6 SO, 6 VT, 6 CV, 8 AEI, 8 AW, 8 AL,
 8 BW, 8 BM, 8 BF, 8 BN, 8 BE, 8 BA, 8 DK, 8 DY, 8 DA, 8 HY,
 0 AB, 0 AR, 0 PE, 0 XP, 0 XN, 0 XF, 0 XD, PE1, 0 FN, 7 ZM,
 7 EC, 7 QF, PA 5, PA 9, 1 MT. (G. Rogers.)

Hammersmith, W.6.
 2 AM, 2 AO, 2 AQ, 2 AZ, 2 BB(?), 2 BC, 2 BO, 2 BZ, 2 CB, 2 CD,
 2 CP, 2 DJ, 2 DI, 2 DU, 2 DY, 2 FQ, 2 FX, 2 FZ, 2 GQ, 2 GT, 2 HA,
 2 HB, 2 HC, 2 HD, 2 HS, 2 IN, 2 IQ, 2 IX, 2 JH, 2 JV, 2 KB, 2 KF,
 2 KK, 2 KL, 2 KO, 2 KW, 2 LF, 2 LG, 2 LU, 2 LW, 2 MF, 2 MK,
 2 MS, 2 MT, 2 MZ, 2 NC, 2 NH, 2 NM, 2 NN, 2 NS, 2 NT, 2 OG,
 2 OH, 2 OQ, 2 OC, 2 FC, 2 FL, 2 FA, 2 FR, 2 FS, 2 PY, 2 PZ, 2 QG,
 2 RN, 2 RS, 2 RU, 2 RW, 2 SA, 2 SF, 2 SH, 2 SL, 2 SK, 2 SQ,
 2 ST, 2 SX, 2 SZ, 2 TI, 2 TJ, 2 TM, 2 TR, 2 UD, 2 UV, 2 VI, 2 VR,
 2 VS, 2 WO, 2 XB, 2 XL, 2 XR, 2 XZ, 2 ZC, 2 ZD, 2 ZR, 2 ZO, 2 WJ,
 2 NF, 2 OZ, 5 AC, 5 AG, 5 AJ, 5 AN, 5 AS, 5 AS, 5 AT, 5 AW, 5 BE,
 5 BM, 5 BT, 5 BV, 5 CB, 5 CF, 5 CS, 5 CX, 5 DC, 5 DM, 5 FZ,
 5 GQ, 5 HA, 5 HI, 5 IO, 5 KO, 5 JP, 5 IS, 5 JJ, 5 KN, 5 KO, 5 LD,
 5 LO, 5 LF, 5 LP, 5 OL, 5 OW, 5 OX, 5 FR, 5 FS, 5 PF, 5 PU, 5 RP,
 5 RQ, 5 SL, 5 ST, 5 SU, 5 TL, 5 TR, 5 VR, 5 VU, 5 VW, 5 WZ,
 6 AL, 6 AW, 6 BA, 6 BC, 6 IM, 6 IL, 6 JX, 6 NF, 6 OX, 6 FS,
 6 SZ, 6 XX, 6 OM, 8 AB, 8 AL, 8 AU, 8 AZ, 8 BF, 8 BM, 8 BT,
 8 CC, 8 CH, 8 CS, 8 CT, 8 JJ, 8 LY, 0 MS, 0 PZ, 0 YS. (0-v-2.)
 (S. Riesen.)

Forthcoming Events.

WEDNESDAY, FEBRUARY 6th.
Institution of Electrical Engineers (Wireless Section). At 6 p.m.
 At Savoy Place, W.C.2. Lecture: "Atmospherics and their
 Effect on Wireless Receivers." By Mr. E. B. Moullin, M.A.
 (Associate Member).
East Ham and District Radio Society. At the C.A. Social Institute,
 Barking Road. Informal Meeting.
Edinburgh and District Radio Society. At 8 p.m. At 117, George
 Street. Business Meeting, etc.
Golders Green Radio Society. At 8 p.m. At the Club House,
 Willfield Green, N.W.11. Lecture: "Plug and Jack Switching."
 By Mr. L. Bland Flagg.
Hampton and District Radio Society. Lecture: "Wireless Experi-
 ments in Spitzbergen." By Mr. E. F. Relf, A.R.C.S.

THURSDAY, FEBRUARY 7th.
Derby Wireless Club. At Derby Chambers, St. Peter's Street.
 Paper on Experimental Apparatus by Messrs. Eccleshare, Lee
 and Parton.
Hackney and District Radio Society. Demonstration of a four-
 valve set, by Mr. L. Robinson, Hackney Borough Electrical
 Engineer.
Horseay and District Wireless Society. Informal Meeting of
 Elementary Members. "Points in Design of Crystal Receivers."
Dewsbury and District Wireless Society. At the Central Liberal
 Club, Dewsbury. Jumble Sale.

FRIDAY, FEBRUARY 8th.
Radio Society of Highgate. At 8 p.m. At Edco Hall, Archway
 Road. Lecture and Demonstration by Mr. G. G. Blake.
Brockley and District Radio Association. At Gladstone Hall,
 New Cross Road. Discussion led by Mr. R. O. Watters.
Sheffield and District Wireless Society. At 7.30 p.m. At the
 Dept. of Applied Science, St. George's Square. Exhibition of
 Members' Apparatus.
Wimbledon Radio Society. At 8 p.m. "Working with America."
 A talk by Mr. J. A. Partridge (2 KF).
Bristol and District Radio Society. Lecture: "Oscillations," by
 Prof. A. M. Tyndall, D.Sc. (illustrated by experiments).

MONDAY, FEBRUARY 11th.
Dulwich and District Wireless and Experimental Association.
 Lecturer from the South London League of Radio Societies.

TUESDAY, FEBRUARY 12th.
Peak Frean Radio and Sports Club. At Kectons Road, Bermondsey,
 S.E.16. Lecture by Capt. A. C. Huss (Monarch Engineering Co.).
West London Wireless and Experimental Association. Experi-
 mental Meeting.

Catalogues and Price Lists Received.

Sterling Telephone & Electric Co., Ltd. (210-212, Tottenham Court
 Road, W.1.). Publication No. 388, artistically illustrating various
 applications for Sterling sets. Publication No. 391, describing
 Sterling Lightweight Head Telephone. Publication No. 363A,
 "Gramophone Record and Voice Amplifying Outfits"; and
 Publication 389, "The Anodion 2-Valve Set."
Mullard Radio Valve Co., Ltd. (45, Nightingale Lane, Balham,
 S.W.12). Lists M.W.4 and V.R.7, dealing respectively with
 Mullard Wecovalves and the One-Valve Ora Valve.
Radio Instruments, Ltd. (12, Hyde Street, New Oxford Street, W.C.1).
 Illustrated pamphlet describing the Lyrianette two and three-
 valve receivers.
Marconi's Wireless Telegraph Co., Ltd. (Marconi House, Strand,
 W.C.2). Series of tastefully prepared pamphlets relating to
 the wide range of Marconiphone receivers, broadcasting equip-
 ment, amplifiers, loud-speakers, etc.
Burndept, Ltd. (Aldine House, Bedford Street, Strand, W.C.2).
 Handsome 96-page catalogue, fully describing the extensive
 range of radio products manufactured by the Company.
Damard Laquer Co., Ltd. (Warwick Street, Greet, Birmingham).
 Booklet entitled, "Bakelite and Its Uses," detailing a variety
 of applications.
The Peto-Scott Co., Ltd. (64 and 99, High Holborn, W.C.1). "Peto
 Scott's Wireless Book," giving an illustrated survey of the subject
 in 69 pages. Price 1s. 3d.
A. J. Stevens (1914), Ltd. (Graiseley House, Wolverhampton).
 "Instructions and Information on Wireless," Price 6d.
"Wireless Bulletin." Issued monthly by G. Davenport (Wireless),
 Ltd., 99-103, Clerkenwell Road, London, E.C.1, and consisting
 of editorial matter together with a well-illustrated section relating
 to the firm's range of wireless sets and components.
Fuller's United Electrical Works, Ltd. (Chadwell Heath, London, E.).
 Illustrated List No. 250B, describing Fuller "Block" Accumu-
 lators for wireless and other purposes. Also List 315 dealing
 with the well-known Fuller Wireless Accessories.

CALCULATION OF CAPACITY.*

By E. J. HOBBS, M.C., Ass.M.I.R.E.

If two or more condensers are connected in parallel they will act as one condenser equal to the sum of the two or all the capacities ; two capacities of equal value in series form one condenser half the capacity of one. These facts may be expressed by—

In parallel $C = C_1 + C_2 + C_3 \dots C_n \dots$ (1)

and in series $C = \frac{1}{\frac{1}{C_1} + \frac{1}{C_2}}$, or $\frac{1}{C} = \frac{1}{C_1} + \frac{1}{C_2} + \frac{1}{C_3}$ (2)

The capacity of a simple condenser consisting of two metal armatures, or plates, separated by a layer of insulating material is found by the formula :

$C (\mu F) = \frac{KA}{4\pi t \times 9 \times 10^5}$ (3)

Where K = the dielectric constant (see table of constants below).

A = the area of one metal plate in sq. cms.
 t = the thickness of the dielectric in centimetres.

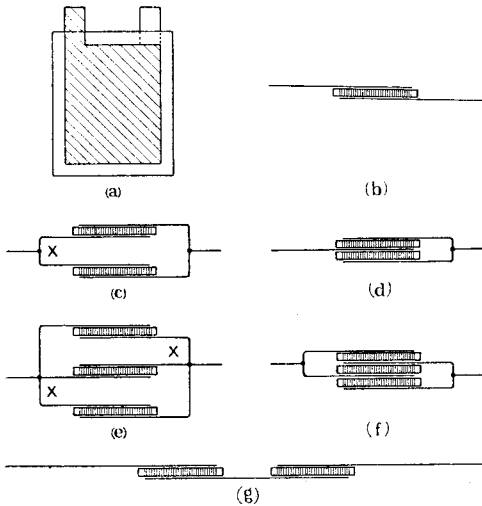

Fig. 1.

Fig. 1 is a graphic illustration of these facts. (a) shows a simple condenser consisting of two metal plates separated by a piece of insulating material such as glass, mica or ebonite called the dielectric. (b) is a sectional view of (a) showing the portion of the dielectric under electrical strain when the condenser is charged and it corresponds to the area of the dielectric covered by the

foil. The edges uncovered are necessary for purely electrical and mechanical reasons and take no active part in the action of the condenser.

- (c) illustrates two condensers in parallel and it will be obvious that as the two plates at the point marked X are connected together one may be removed and the whole closed up as in (d). We then utilise both sides of the plates and a saving in material is effected, but the number of dielectrics remains unchanged.
- (e) shows how three small condensers are paralleled and how the two plates at the point X can be reduced to one. (f) is the result. Any number can be built up in this way.
- (g) represents two condensers in series.

It will now be apparent that we need only consider the number of dielectrics in our calculations and imagine each one to represent a small condenser, of which the active portion is the area covered by the foils ; in other words we calculate for n dielectrics of the size of the metal plates. It will also be noticed that one plate more than the number of dielectrics will always be required.

A table or graph which takes into consideration some fixed value for the dielectric constants of mica, glass, etc., will not suit all cases. All insulating materials have constants which can only be measured by means of delicate apparatus and the equivalent value is based on that of air, for which $K = 1$. The normal values are shown in Fig. 2, and the quality of the material governs its constant.

DIELECTRIC CONSTANTS.

Dielectric.	Value of K .
Air	1
Glass (common)	3—3.25
Glass (flint)	6—7
Ebonite	2—2.25
Paraffin	2 (varies enormously)
Mica	5—8

Fig. 2.

The author has therefore taken these facts into consideration and has based all calculations on one sheet of dielectric (equivalent to two metal plates of the dimensions specified) the dielectric being air and having a constant value of 1.

Fig. 3 is a table of areas of one sheet of foil (or the equivalent dielectric under strain) for capacities of 0.0001 to 0.001 mfd. and thicknesses of dielectric between 0.001 cm. and 0.01 cm. Higher or lower values of capacity can be calculated from the table in the following manner.

*Second portion of a paper read before the Radio Society of Great Britain at a meeting held on December 19th at the Institution of Electrical Engineers.

For capacities 0.0001 to 0.0001 *divide* the area by 10.

For capacities 0.001 to 0.01 *multiply* the area by 10.

For capacities 0.01 to 0.1 *multiply* the area by 10².

For capacities 0.1 to 1.0 *multiply* the area by 10³.

For example, for a capacity of 0.1 mfd., with a dielectric of air 0.001 cm. thick, the area necessary is 10² greater than for 0.001 mfd. using the same dielectric, which is 11.31 sq. cms. for the latter capacity. 11.31 × 10² = 1,131 sq. cms. for 0.1 mfd.

Graph F will appeal to the more discriminate experimenter as he can obtain any intermediate value, the widest possible range of capacities and dimensions being covered. The correct area for any value of *K* may be read off direct by means of the slide. To use slide *K*: read off the graph the area in sq. cms. for the capacity required and place the slide so that the value of *K* is against the area on the graph when the left-hand index (at 1) will point to the actual area necessary. Always use the left-hand index, if possible, but if it protrudes beyond the limits of the graph, use the right-hand index and *divide* the answer by 10.

Thickness in Centimetres.	Capacities in Microfarads.					Areas 1 Plate in Sq. Cms.				
	.0001	.0002	.0003	.0004	.0005	.0006	.0007	.0008	.0009	.001
.001	1.1310	2.2620	3.3929	4.5239	5.655	6.786	7.917	9.048	10.179	11.3098
.002	2.2620	4.5239	6.7859	9.0478	11.310	13.572	15.834	18.096	20.358	22.6195
.003	3.3929	6.7859	10.1798	13.5717	16.965	20.358	23.751	27.144	30.537	33.9293
.004	4.5239	9.0478	13.5717	18.0956	22.620	27.144	31.668	36.192	40.716	45.2390
.005	5.6549	11.3098	16.9645	22.6195	28.275	33.930	39.585	45.240	50.895	56.5488
.006	6.7859	13.5717	20.3576	27.1434	33.930	40.716	47.502	54.288	61.074	67.8586
.007	7.9168	15.8337	23.7505	31.6673	39.585	47.502	55.419	63.336	71.253	79.1683
.008	9.0478	18.0956	27.1434	36.1912	45.240	54.288	63.386	72.384	81.432	90.4781
.009	10.1788	20.3576	30.5364	40.7151	50.895	61.074	71.253	81.432	91.611	101.7878
.01	11.3098	22.6195	33.9293	45.2390	56.550	67.860	79.170	90.480	101.79	113.0976

For Capacities .00001 to .0001 *divide* by 10.
 " " .001 to .01 *multiply* by 10.
 " " .01 to .1 " " 10².
 " " .1 to 1 " " 10³.
 " " 1 to 10 " " 10⁴.

For Thicknesses .0001 to .001 cm. *divide* by 10.
 " " .01 to .1 cm. *multiply* by 10.
 " " .1 to 1 cm. " " 10².

Fig. 3.

If we reduce the thickness of the dielectric we shall require a *smaller* area; for thicker dielectric a *greater* area is necessary to obtain the same capacity. Hence:

For thickness 0.0001 to 0.001 cm. *divide* A by 10.

For thickness 0.1 to 0.1 cm. *multiply* A by 10.

For thickness 0.1 to 1 cm. *multiply* A by 10².

These values are all for condensers with a dielectric of air (*K* = 1), and to obtain the areas necessary for a given material, such as glass or mica, the reader should *divide* the area by the value of *K* he considers will be correct for the material he intends to use. He may have purchased some first-grade ruby mica and assume it will have the highest insulating qualities, when, say, *K* = 8; on the other hand it may be the mica usually sold for oil lamp windows, and have a value as low as 5 or 5.5. In these matters he must use his discretion.

The earlier remarks regarding higher and lower capacities and greater or lesser thicknesses of dielectrics mentioned in connection with the table of figures (Fig. 3) are also applicable to the graph. We therefore have a simple method of determining the dimensions of *all* capacities under *all* conditions.

We may now consider the application of the foregoing data to variable condensers of the semi-circular vane type.

If the capacity of a rectangular condenser is determined by:

$$C \text{ cms.} = \frac{KA}{4\pi t^2} \text{ or, when } K \text{ is unity, } C = \frac{A}{4\pi t^2}$$

$$\text{and } C \mu F = \frac{A}{4\pi t \times 9 \times 10^5}$$

When using semi-circular variable condensers:

$$A = \frac{\pi(R^2 - r^2)}{2} \text{ or } 1.5708 (R^2 - r^2).$$

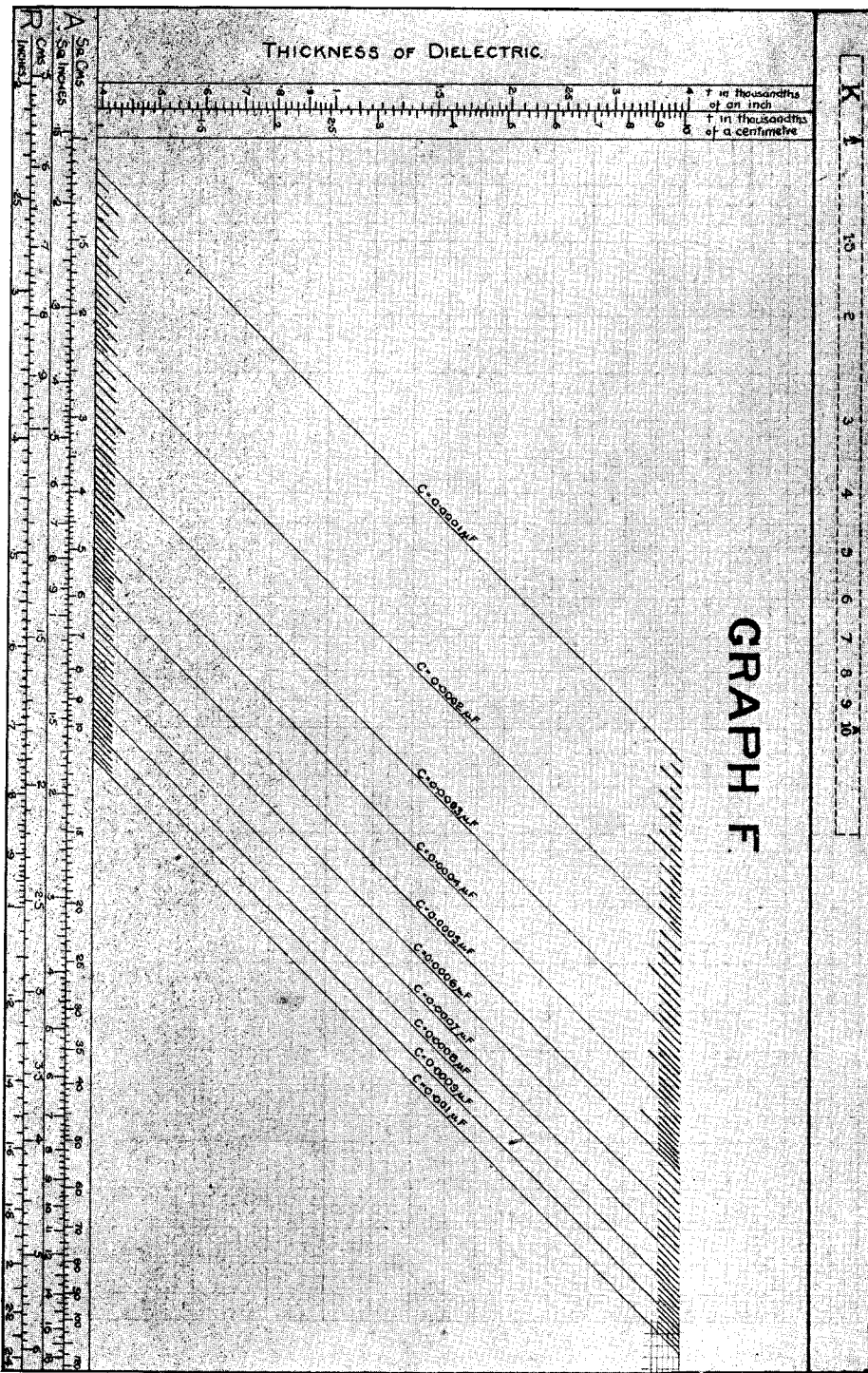

A direct reading graph enabling one to read off the capacity of a condenser when its dimensions are known.

Where A is the equivalent rectangular area of a semi-circle.

R = radius of the outside edge of the moving plate.

r = radius of the centre hole in the fixed plate.

Substituting for A :

$$C \text{ cms} = \frac{\pi(R^2 - r^2)}{2 \times 4\pi t} = 0.125 \frac{(R^2 - r^2)}{t}, \text{ or}$$

$$C \mu F = \frac{\pi(R^2 - r^2)}{2 \times 4\pi t \times 9 \times 10^5} = \frac{R^2 - r^2}{72 \times 10^6 t}, \text{ or}$$

$$C \mu\mu F = \frac{10\pi(R^2 - r^2)}{72\pi t} = 0.139 \frac{(R^2 - r^2)}{t}.$$

This agrees with the complete formula, viz. :

$$C \text{ cms.} = Kn \frac{\pi(R^2 - r^2)}{4\pi t} \times \frac{\theta}{360}$$

Where K is the dielectric constant (for air $K = 1$).

n = number of sheets of dielectric.

R = radius of outside edge of moving plates.

r = radius of central hole in fixed plate.

t = thickness of dielectric.

θ = angle through which moving plates vary from point of minimum capacity.

All dimensions are in centimetres.

Consider the case when $R = 6$ cms. and $r = 0.5$ cms. :

$$A = \frac{\pi(R^2 - r^2)}{2} \text{ or } 1.5708 (R^2 - r^2) \text{ and}$$

substituting known dimensions A (sq. cms.) = $1.5708 (6^2 - 0.5^2) \times 56$ sq. cms.

Referring to graph F and assuming the thickness of dielectric to be used is 0.008 cm. we see that a condenser of these dimensions will have a capacity of 0.000618 μF .

Checked by the formula $C \mu\mu F = 0.139 \frac{(R^2 - r^2)}{t}$

$$C = 0.139 \frac{35.75}{0.008} = 621 \mu\mu F \text{ or } 0.000621 \mu F.$$

When r is small it may be neglected and the formula further simplified to :

$$A = 1.5708 R^2, \text{ or } C = \frac{0.139 R^2}{t}$$

The previous example worked by this method is $A = 1.5708 \times 6^2 = 56.55$ sq. cms.

Reading from graph F, when $A = 56.55$ sq. cms. and $t = 0.008$ cms. $C = 0.000625$ mfd. ; and by formula

$$C \mu\mu F = 0.139 \frac{R^2}{t} = \frac{0.139 \times 36}{.008} = 625 \mu\mu F \text{ or}$$

0.000625 μF .

A condenser which approximates a size commonly used will be considered as a further example.

Moving plates = $2\frac{1}{2}$ " diameter = $1\frac{1}{4}$ " radius = 3.175 cms.

Thickness of spacing washer = 0.095".

Thickness of moving plate = 0.023".

$$\therefore \text{Thickness of dielectric} = \frac{0.095 - 0.023}{2}$$

= 0.036" = 0.09144 cm.

$$A = 1.5708 R^2 = 1.5708 \times 3.175^2 = 15.933664.$$

Reading from the graph with an area of 15.93 sq. cm., and a dielectric thickness of 0.0009 cm. (0.09144 = 0.09 approx.), $C = 0.000157 \mu F$. As the thickness of the dielectric was divided by 10

the area must also be divided by 10, $\therefore C = 0.000157 \mu F$ or $15.7 \mu\mu F$. Checked by the formula :

$$C \mu\mu F = 0.139 \frac{R^2}{t} = 0.139 \times \frac{10.08}{0.09} = 15.7 \mu\mu F.$$

If the size of the complete condenser required is 1,000 $\mu\mu F$ (0.001 μF), and one plate has a capacity of 15.7 $\mu\mu F$, the number of plates will be 15.7 : 1 :: 1000 : 63.7, or approximately 64 plates, to which the one extra plate illustrated in Fig. 1 must be added. Thirty-three fixed plates and 32 moving plates (65 in all) will therefore give the desired capacity. These figures may be checked by the table on p. 311, *The Wireless World and Radio Review*, for June 9th, 1923.

The advantage of using the graph method is flexibility ; readers are not limited to fixed dimensions given in the average table.

It will also be noticed that the capacities in microfarads and the lines representing thicknesses of dielectric on Graph F are interchangeable, i.e., if instead of 0.0002 μF we read as $t = 0.0002$ cm. and the line $t = 0.002$ cm. as 0.002 μF , the area of foil will be 4.5 sq. cms. In this manner one graph serves the purpose of two and enables intermediate values of t to be used by transposing t and c .

To further reduce calculations an additional scale is drawn at the foot of the graph to enable the area to be read off direct if the radius is known, or vice versa. For example : a vane having a radius of 1 cm. has an area of 1.57 sq. cms. ; a radius of 2 cms. = 6.28 sq. cms., etc., etc.

The writer desires to acknowledge the valuable assistance and suggestions given by his assistant, H. A. Talbot.

DISCUSSION.

A Member.

I have seen it stated that you can leave out K in the formula for inductance. What is the percentage of error if you do that ?

The President.

This is an exceedingly interesting paper, and the author has spent a great deal of labour on these graphs. I have done a little bit of that sort of thing myself in former years when I was younger and more energetic, and there is a great deal of labour in them. They are, of course, really labour-saving devices for other people, but not for the person who makes them, and I think the fact that the author does save labour for other people is very greatly to his credit from the point of view of his public spiritedness.

The Author.

With regard to the question about the correction factor K for ordinary cylindrical coils, one should always find the correction factor K . I have a graph showing the correction factor K . When the ratio of diameter to length is 5, you will find that it reduces the actual inductance of the coil to 0.3 of the calculated inductance without the correction factor K . Supposing you had an inductance of 100 μH , that would reduce your actual inductance to a matter of 30 microhenries, so that correction factor K is rather important. Otherwise you may have misleading results.

A hearty vote of thanks was accorded the author.



WITH THE SOCIETIES

Particulars of Membership of any Society can be obtained on application to the Secretary. Societies marked with an asterisk are affiliated to the Radio Society of Great Britain.

Wimbledon Radio Society.*

A constructional evening was held on Friday, the 11th inst. Work was done on the Society's set, and members were also able to use the bench for their own work.

The Hon. Sec., Mr. C. G. Stokes, of 6, Worple Avenue, Wimbledon, S.W.19, will be pleased to answer enquiries from prospective members and others, with regard to membership.

Barnet and District Radio Society.*

The annual general meeting of the Society was held on Wednesday evening, January 23rd, when Mr. F. W. Watson Baker presided over a large gathering of members.

After a satisfactory financial statement had been presented by the Treasurer, Mr. C. Randall, the Hon. Secretary, gave a brief and encouraging report on the work of the Society since its inauguration last year. The membership had now reached nearly sixty. He referred to the affiliation of the Society to the Radio Society of Great Britain, and said that in his opinion the Society would rapidly gain further support in the district.

Following the re-election of the principal officers the following appointments, among others, were also made:—Mr. C. Crane, Assistant Secretary; Mr. H. K. Nield, Social Secretary; and Mr. D. Plank, Press Secretary and Publicity Agent. The committee was re-elected *en bloc*, and Mr. R. Cook was appointed as the Society's representative to the Radio Society of Great Britain.

After discussion it was decided to hold meetings fortnightly throughout the year on the first Monday and third Wednesday in every month.

Particulars of membership can be obtained from the Hon. Sec., J. Nokes, Sunnyside, Stapylton Road, Barnet.

The Lewisham and Catford Radio Society.*

On Thursday, January 17th, the Society held its annual general meeting, at which the officers for the forthcoming year were elected. It was with deep regret that the Society accepted the resignation of Mr. F. A. L. Roberts from the office of Hon. Secretary. The Chairman stated that his successor must be "a real live wire that can be depended on not to fuse," and the Society placed their confidence in Mr. C. E. Tynan, in whom, it is felt, the Society have a man very worthy of the office. The programme for the next two months was enthusiastically received and members gave their vote of support to the coming Society dinner and smoker.

The meeting closed by the Chairman wishing all members a very happy and prosperous New Year.

Hon. Sec., C. E. Tynan, 62, Ringstead Road, Catford, S.E.6.

Tottenham Wireless Society.*

"Alternating Currents" formed the subject of a lecture delivered by Mr. J. Kaine-Fish on Wednesday, January 16th. Dealing with both the theory and practical uses of A.C., the lecturer showed the development of the dynamo and electric motor. On Wednesday, January 23rd, in Mr. Vickery's absence, the Secretary dealt with portions of the lecture that Mr. Vickery had prepared on "Telegraphy and Telephony." Various telegraph and telephone systems were briefly touched upon, and an interesting discussion took place on microphones and receivers.

Mr. Grimshaw followed with a talk on "The Ideal Set" from an experimenter's point of view, giving details of his own set, and calling for the views of those present as to the best lay-out of components.

Hon. Sec., S. J. Glyde, 137, Winchelsea Road, Bruce Grove, Tottenham, N.17.

Wireless and Experimental Association.*

The annual dinner of the Association took place at Odone's Restaurant, 152, Victoria Street, S.W.1, on Saturday, January 26th.

The Press was well represented, and Mr. Bishop, of the British Broadcasting Co., attended in the place of Capt. Eckersley, who was prevented from being present.

The repast was sumptuous, the entertainment excellent, and the speeches superlative.

Hon. Sec., Geo. Sutton, 18, Melford Road, S.E.22.

The Stoke-on-Trent Wireless and Experimental Society.*

On Thursday, January 17th, an instructive lecture was given by Mr. J. G. Jackson, B.Sc., of Sheffield, on the "Electron." The lecturer drew attention to the fact that the weight of the electron varied according to the speed at which it was travelling, becoming heavier the faster it moved, and concluded a most interesting lecture by describing the different methods of getting electrons out of solid bodies.

Hon. Sec., F. J. Goodson, B.Sc., Y.M.C.A., Marsh Street, Hanley.

Radio Association of Ireland.

The annual general meeting was held on January 15th, at the Red Bank Restaurant, D'Olier Street, Dublin. The annual report and Treasurer's statement, which showed the funds to be in a very strong condition, were read and unanimously adopted.

After the principal officers had been re-elected several important resolutions were passed. It was voted unanimously that, in the opinion of the members of the Association, any broadcasting station

or stations which may be set up in the Free State should be so arranged with regard to power, wavelength and locality as not to interfere in the reception of any existing broadcasting stations in other countries.

At the special meeting, held in the Technical Schools, Kevin Street, on January 23rd, Mr. Byrne gave an interesting lecture on the reception of wireless signals, this being a continuation of a previous discourse by Mr. A. L. Callan on the same subject.

Hon. Secretary, J. P. Murphy, 45, Henry Street, Dublin.

Northampton and District Amateur Radio Society.

A meeting of the Society was held at the County Café on Monday, January 21st, when Mr. A. E. Turville, who has given a number of lectures and practical demonstrations on wireless, showed his versatility by delivering an interesting discourse on "light." Unfortunately, lack of time prevented the lecturer from touching more than briefly on many interesting points, and a further lecture would be welcomed.

Press Sec., M. Hipwell, The Governor's House, Campbell Square, Northampton.

Brockley and District Radio Association.

The second of the new series of elementary lectures took place on Friday, January 11th, "Adding a Valve" being the subject treated by the lecturer, Mr. W. F. Emberley. A number of advanced lectures and demonstrations is in preparation.

The annual general meeting of the Association took place on January 18th.

The Chairman announced with regret that the Hon. Sec., Mr. R. O. Watters, did not wish to stand for re-election, and referred to the untiring work of Mr. Watters during his term of office. It was also regretted that the Hon. Treasurer, Mr. E. W. Campwell, was also obliged to hand in his resignation.

The following appointments were made for the ensuing year:—Chairman, Mr. B. Hughes; Vice-Chairman, Mr. W. F. Emberley; Hon. Secretary, Mr. Harrie King; Hon. Asst. Secretary and Treasurer, R. W. Allwright. The old Committee was re-elected *en bloc* with four new additions.

It is with deep regret that the Society has to announce the recent death of its esteemed President, Dr. Walsh.

At the conclusion of the evening's business, a practical demonstration of soldering was given by Mr. Thomas Hancock.

Prospective members are invited to communicate with the Hon. Sec., Harrie King, 2, Henslowe Road, East Dulwich S.E.22.

Westminster Wireless and Experimental Association.

"Induction Coils and X-Ray Work" formed the subject of an informative lecture given by Mr. G. A. Phillips on January 15th.

A two-valve reflex circuit was demonstrated by the Chairman, Mr. J. Waterfall, excellent results without an aerial being obtained on the loud speaker.

All enthusiasts in the Westminster district are invited to become members of the Society.

Hon. Sec., J. Dove, 77, Pimlico Road, S.W.1.

Belvedere, Erith and District Radio and Scientific Society.

The sixth of a series of elementary lectures was given by Mr. S. G. Meadows, on Monday, January 14th. The lecturer dealt with the most popular dual circuits, describing how to build them up by means of blackboard illustrations. Several reflex circuits, he said, were unsuitable for broadcast reception on account of their instability, being liable to break into oscillation if the crystals were not properly set.

On Friday, January 18th, Mr. R. G. Hershell lectured on the electrification of the L.S.W. section of the Southern Railway, his remarks being illustrated by an excellent series of lantern slides.

Hon. Sec., S. G. Meadows, 110, Bexley Road, Erith, Kent.

Battersea and District Radio Society.

An instructive and entertaining lecture on "Television" was given on January 17th by Mr. G. A. Waiter, of Messrs. The General Radio Co. By means of the blackboard the lecturer gave his audience some interesting and useful information regarding transmitting and receiving the light rays which render television possible.

A series of instructional lectures by prominent manufacturers is being arranged, the first taking place on January 31st, and delivered by Messrs. Fullers. All interested are given a hearty welcome. Particulars of membership can be obtained from the Hon. Sec., Thos. M. Norris, 39, Warriner Gardens, Battersea, S.W.11.

Hall Green Radio Society.

A well attended meeting took place on Wednesday, January 16th, when Mr. J. L. Owen gave an interesting lecture dealing with the chemistry of cells and accumulators.

It has been decided that the Society shall meet weekly in future, instead of on the first and third Wednesdays of the month, as at present.

Hon. Sec., F. C. Rushton, 193, Robin Hood Lane, Hall Green, Birmingham.

Dulwich and District Wireless and Experimental Association.

At the headquarters of the above Association, on January 7th, the attraction of the evening was provided by Mr. Harrie King, who delivered a lecture and demonstration entitled "The Hinton Receiver." The lecturer was ably assisted at the blackboard by Mr. J. Barrett.

A full programme for the 1924 season is now ready, and full information will be readily supplied to all interested, by the Hon. Sec., Harrie King, 2, Henslowe Road, East Dulwich, S.E.22.

The Radio Research Society.

Two instructive lectures were given on January 16th. The first, on "Accumulators," was delivered by Mr. A. Simmonds, who dealt exhaustively with the subject, and explained the cause of many of our troubles.

The second lecture was given by Mr. R. S. Austin on "Methods of Calculating

Inductance." By aid of the blackboard Mr. Austin was able to simplify matters considerably, and worked out several examples.

There are still vacancies in the Society for genuine experimenters. Full particulars can be obtained from the Hon. Sec., Arthur H. Bird, 35, Bellwood Road, Waverley Park, Nunhead, S.E.15.

presiding, it was decided to form a society to be known as the "Bangor and District Radio Society," the membership fees being tentatively fixed at ros. for adult and 5s. for junior members.

The appointment of president was deferred, but Mr. W. E. Williams was appointed Vice-President, Mr. J. Cecil Hughes-Roberts, Hon. Secretary, and

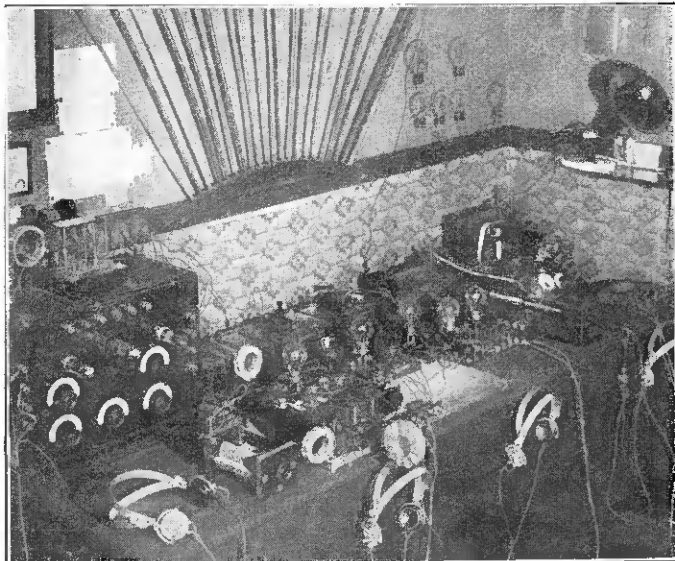

The experimental receiving station of Mr. C. A. Marlowe, of Whalley Range, Manchester. The three-valve instrument on the left receives, besides British broadcasting, the transmissions from Berlin, Paris, and Brussels. Quick interchange of circuits is provided for by the experimental panel in the centre.

University College School Radio Society.

Formed over a year ago, this Society has a steadily increasing membership now exceeding fifty.

In addition to constructing a three-valve set, the members have had the opportunity of hearing several instructive lectures given by Captain A. Hinderlich, M.A., and by Mr. Keith N. V. Rogers, whose demonstration of an "Armstrong Super" receiver roused great interest. "Dual Amplification" has been discussed upon by Mr. F. D. Chard, and an excellent series of "Beginners' Lectures" has been provided by Mr. S. K. Lewer (6LJ).

Hon. Sec., F. D. Chard, University College School, Hampstead.

Brighton and Hove Radio Society.

"The Manufacture of Wireless Valves" was the title of an interesting lecture given by Mr. Wade, of the Marconi-Osram Valve Co., on Thursday, January 17th. All types of valves, from the smallest receiving valve to the most powerful transmitter, were described in their different stages of construction, and through the courtesy of the Marconi-Osram Valve Co., the processes were clearly explained with the aid of some excellent lantern slides.

Hon. Sec., D. F. Underwood, 58, Southdown Avenue, Brighton.

The Bangor and District Radio Society.

At a well attended public meeting held at the Y.M.C.A. on Thursday evening, Mr. W. E. Williams, B.Sc.,

Mr. Walter Horsley, B.Sc., Hon. Treasurer.

The drafting of the Rules was entrusted to a Committee comprising the officials and Messrs. Wright, Watkinson, J. Morris (Central School), J. Fielding, O. N. Roberts, D. Senogles, A. R. Brooks, and D. Mountfort. It was also decided to have a workshop attached to the Society for the use and instruction of members and to arrange classes and lectures.

The proceedings throughout were full of enthusiasm and augured well for success. Meetings will be held at the Y.M.C.A. on Wednesdays in future, at 7.30 p.m., and intending members should send their names to the Hon. Sec. as soon as possible.

Hon. Secretary, J. C. Hughes-Roberts, 3, Snowdon Villas, Bangor.

Wandsworth Wireless Society.

The Society held a very enjoyable social afternoon at the "Pavilion," Lavender Hill, Battersea, on Sunday, January 13th, by kind permission of Capt. E. S. Davis.

A most agreeable surprise was the musical talent present in the Society, a very excellent programme being provided.

Considerable interest was aroused by a lecture from Capt. Davis, on "Accumulator Charging from A.C. Mains."

The programme concluded at 6 p.m. and was followed by tea in the Lounge Hall.

Hon. Sec., F. V. Copperbeet, Wandsworth, Technical Institute, High Street, Wandsworth, S.W.18

CORRESPONDENCE.

THE LEAFIELD HARMONICS.

To the Editor of THE WIRELESS WORLD AND
RADIO REVIEW.

SIR,—I was very pleased to see Mr. A. B. Smith's letter on the subject of interference by Government high power stations in your issue of December 19th.

If he lived nearer to Leaffield it is probable that he would not have expressed his opinion so moderately.

He asks what has been done by others to eliminate this nuisance.

Probably there is no branch of wireless experiment which has received greater attention from those who are unfortunate enough to work close under the influence of Leaffield, for no matter what line of investigation is taken up, the outstanding feature will be harmonics from this station, and before any satisfactory results can be obtained their influence must be reduced.

I regret to admit that at present, although many of us have spent much time and money on the subject, I know of no means by which this interference can be overcome.

Although still a most enthusiastic experimenter, I must admit that this fight against an almost overwhelming force is becoming a little disheartening. Others have given up the unequal contest already.

The results are clearly shown in your pages. Look at the lists of Transatlantic Receptions; they are, with very few exceptions (one of which is at Oxford), all of stations at a considerable distance (at least 40 miles) from Leaffield.

The reception at Oxford was a query after it and was probably made during one of Leaffield's silent periods.

Again, there is no Wireless Society in Oxford; this may be attributed directly to the fact that interference renders experimenting a misery rather than a pleasure. On various occasions during the past year, rumours have been heard of changes which would cut out these harmonics, but up to the present there is not the least improvement.

Rugby station, when finished, will probably increase the trouble.

A possible solution, as far as broadcasting is concerned, would be to use Leaffield as the B.B.C. station and transmit by land-line or wireless from the various centres. Its geographical position should be excellent for this purpose and this scheme should meet most requirements except "local news," etc., which could be dealt with by small stations with reduced staffs.

It is to be hoped that endeavours will be made to get this interference nuisance

"WIPED OUT."

Oxford.

To the Editor of THE WIRELESS WORLD AND
RADIO REVIEW.

SIR,—In his paper on the Leaffield Station, reported in your issue of January 2nd, Mr. E. H. Shaughnessy states that this station is really not much to be blamed in respect to its harmonics,

and that often harmonics of other stations are attributed to **GBL**. This may be so, but I have gone to a little trouble to trace the harmonics of Leaffield and have followed this station right down from 8,750 metres to the wavelength of **2 LO**. For example, when listening to **2 LO**'s relay of America at midnight recently, a harmonic of Leaffield was clearly heard calling. (I may say that I only trace the harmonics by reading Morse, so that there is no question about it.) True, I am only 35 miles from Leaffield, but certainly at this distance Leaffield's harmonics are very intrusive indeed. When using two valves and trying to get the more distant Morse stations, at almost any wavelength, one is pretty certain of hearing a harmonic of this station.

The next worst station is the very high-powered one in Holland, **PCG**, which is calling to Dutch East Indies, but naturally I have not been able to trace his harmonics anything like so far down.

ERIC W. WALFORD.

Coventry.

AMERICAN CALLS HEARD.

Snath, Yorks.

1 **AYI** (R 4-5, calling **8 BDL**), 1 **CMP** (R 8-9, fading), 1 **AR**, 1 **PA**, 1 **XM**, 2 **CXL** (Nov. 29th, Dec. 6th, CQ calls), 3 **AJO** (CQ calls), 4 **FT** (CQ calls), 8 **WFF**. (J. L. Greatorax).

Dovercourt, Essex.

(Dec. 1st-8th): 9 **BAK**, 5 **FV**, 1 **CMP**, 3 **AJD**, 1 **RR**, 4 **HN**, 4 **EB**, 9 **ZT**, 2 **BY**, 2 **BG**, 3 **TJ**, 1 **BVE** (1 valve, R 7), 4 **FT**, 1 **AW**, 8 **XAN**, 8 **NE**, 3 **AJD**, 2 **AF**, 1 **AR**, 8 **AMM**, 8 **CUY**, 9 **BWK**, 8 **GS**, 1 **YB**, 1 **BDL**, 9 **VM**, 9 **CTB**, 1 **VV**, 8 **XE**, 4 **FG**, 8 **OS**, 8 **HN**, 9 **AN**, 1 **BQ**, 9 **AN**, 2 **RK**. (0-1-1) F. R. W. Stralord).

Monkseaton, Northumberland.

(Dec. 9th): 2 **KIL**, 5 **ERP**, 9 **ST**, 2 **DY**, 6 **5AT** (calling 2 **CMP**), 2 **BGR**(?), 2 **BRM**(?). (1-1-1) W. Brian Parker.

Finchley, N.3.

1 **OA**, 2 **CCK**, 2 **CG**, 3 **TE**, 3 **AEC**, 4 **AE**, 9 **XW**. (Single valve Armstrong). E. L. Gardiner.

Hammersmith, London, W.6.

A 1 **AG**, A 1 **AR**, A 1 **ARR**, A 1 **ASU**, A 1 **MO**, A 1 **NE**, A 1 **CMP**, A 1 **WRT**, A 1 **XW**, A 2 **BY**, A 2 **CY**, A 2 **LZ**, A 2 **WR**, A 3 **WP**, A 3 **IM**, A 3 **IL**, A 3 **TK**, A 5 **EV**, C 5 **XA**, PA 9(?). (0-1-2) (S. Riesen.)

Ashford, Middlesex.

1 **AQY**, 1 **AQI**, 1 **AJA**, 1 **OAL**, 1 **BRL**, 1 **BWJ**, 1 **BES**, 1 **CJK**, 1 **JW**, 1 **PA**, 1 **FV**, 1 **XAM**, 2 **AGY**, 2 **AWL**, 2 **BY**, 2 **BQH**, 2 **BQA**, 2 **CEL**, 2 **CRP** (verified), 2 **FP**, 2 **XT**, 3 **BDO**, 3 **BXW**, 3 **BFU**, 3 **OO**, 5 **IE**, 7 **FU**, 8 **BCI**, 8 **CLI**. Later, 6 **AWT**, 9 **ZN**, 9 **XT**, 9 **AAU**, 1 **XM**, 1 **AW**. (G. Rogers.)

Change of Address.

Mr. R. Watson (5 **HA**), to 8, Cranley Gardens, S.W.7.

Wanted: Reports of Reception.

2 **QR**, owned by Mr. Gilbert Towers, of 12, Mayfield Road, Handsworth, Birmingham, is now operating on 200 metres on a power of 20 watts (tonic train). Reports from any district will be welcomed.

Mr. F. J. Devenish (2 **ADQ**), of 13, Marlboro' Road, Bowes Park, London, N. 22, desires reports of his transmissions, which are carried out on 200 metres (C.W. and telephony) with a power of 10 watts.

Similarly, reports of his transmissions will be welcomed by Mr. H. T. Littlewood (2 **XY**), of "Esholt," Wedgewood Drive, Roundhay Leeds. (C.W. and telephony).

Questions & Answers

Solutions of Readers' Difficulties

1. All questions are answered through the post. A selection of those of general interest is published.
2. Not more than four questions may be sent in at any one time.
3. Every question should be accompanied by a postal order for 1/-, or 3/6 for four questions, and by a coupon taken from the current issue.
4. Alternatively, advantage may be taken of our free service by using the free coupon. This appears in the first issue of each month, and is valid during the current week only.

"G.T.B." (Clacton) asks for a diagram of a three-valve receiver suitable for general reception.

The diagram is given in Fig. 1. The first valve acts as a high frequency amplifier with reaction to the tuned anode circuit. A switch is provided to cut out the L.F. valve when not required.

"R.C.D." (Wolverhampton) asks if it would be possible to decrease the volume of sound from a loud speaker by detuning, dimming filaments, etc.

This method of varying the volume given by a loud speaker is not recommended, as distortion

is almost certain to occur. The signal should be accurately tuned and the filament current to each valve should be that normally required for the value of H.T. used. The volume given by the loud speaker should then be controlled by the number of L.F. valves in circuit.

"W.S.B." (Birmingham) asks how a receiver circuit may be modified in order to eliminate interference from the local broadcasting station.

A filter circuit may be coupled with the aerial circuit. This consists of a coil of about 50 turns of No. 22 D.C.C. on a 3" diameter former, tuned by

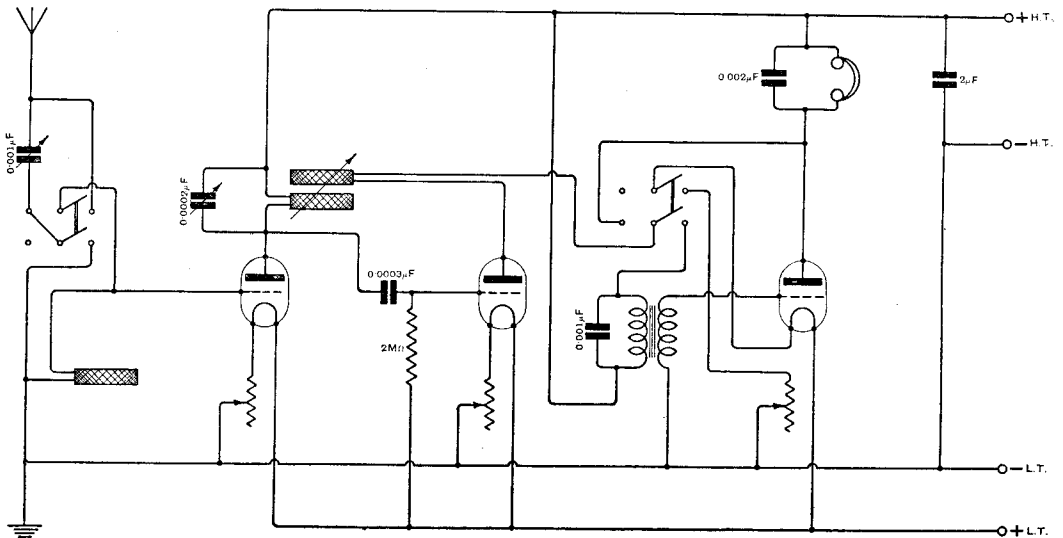

Fig. 1. G.T.B. (Clacton). A simple three-valve receiver.

a 0.0005 variable condenser. This circuit should be tuned to the wavelength of the local transmitter, and coupled to a coil of about 10 turns, included in the aerial circuit. For other methods of preventing interference we would refer you to an article on page 384 in the issue of June 23rd, 1923.

"W.T.P." (London, N.22) asks whether there is any appreciable difference between crystal and valve rectification after a H.F. amplifier.

In general, valve rectification is to be preferred, especially when more than one stage of H.F. amplification is used. Crystal detectors are not suitable for rectifying H.F. currents of large amplitude, and their resistance often produces serious damping in the tuned circuit across which they are connected. In general we recommend the use of crystal rectification only after one stage of H.F. amplification.

windings, while the L.F. telephone currents pass through the parallel circuit formed by the loud speaker and 0.2 μ F condenser. This system prevents damage to the windings of the loud speaker from the steady anode current.

"C.B." (London, S.E.4) asks if it would be possible to use a single-valve resistance capacity coupled L.F. amplifier in conjunction with a crystal set.

Where only one stage of L.F. amplification is employed, the amount of distortion introduced by an iron core transformer is negligible. Under these circumstances there is no advantage from the point of view of quality in using the resistance capacity method of coupling, and we therefore recommend that you use transformer coupling, since the degree of amplification obtained will be much greater.

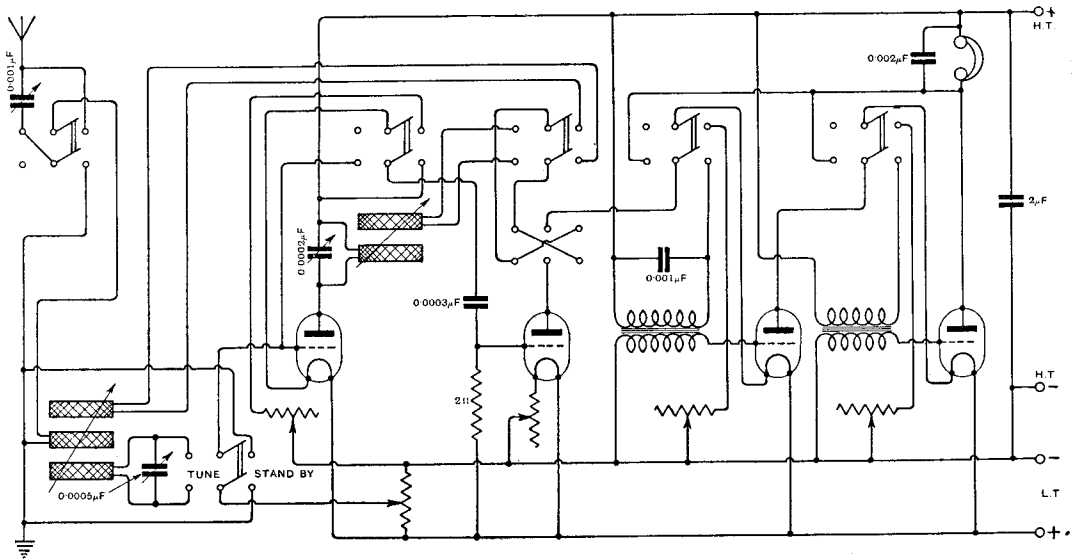

Fig. 2. "A.N." (Northwich). An "all-purpose" four-valve receiver.

"A.N." (Northwich) asks for a diagram of a receiver to operate a loud speaker, which can be recommended for general reception.

The diagram in Fig. 2 shows an arrangement which will give good results. One stage of H.F. amplification is used, followed by a detector and two note magnifiers. Switches are provided to control the number of valves in use and to reverse the reaction coil.

"W.M." (London, N.15) asks what is the function of the last L.F. transformer in the cabinet receiver described in the issue of October 31st.

The primary and secondary windings of this transformer are connected in series to form a single choke coil, which is connected in the plate circuit of the last valve. The steady plate current to this valve passes through the transformer

"T.B." (London, N.W.11) has trouble with self-oscillation in an L.F. amplifier.

Howling is often caused in L.F. amplifiers by the H.T. battery having a high internal resistance. The H.T. battery should be shunted by a reservoir condenser of not less than 1 μ F, and the secondary windings of the transformers should be shunted with resistances of the order of 0.5 megohms.

"S.G.J." (London, N.W.6) asks if steel could be used for the construction of variable air dielectric condenser vanes.

The vanes of a variable condenser should be constructed of a non-ferrous metal, such as brass or aluminium. Small currents flow in the plates when the condenser is charged and discharged, and losses would result from hysteresis in the steel when subjected to the magnetic fields produced by these currents.

THE WIRELESS WORLD AND RADIO REVIEW

THE OFFICIAL ORGAN OF THE RADIO SOCIETY OF GREAT BRITAIN.

No. 235. (No. 20.
Vol. XIII.)

FEBRUARY 13th, 1924.

WEEKLY

EDITOR:
HUGH S. POCKOCK.

RESEARCH EDITOR
PHILIP R. COURSEY, B.Sc., F.Inst.P., A.M.I.E.E.

ASSISTANT EDITOR:
F. H. HAYNES.

QUESTIONS AND ANSWERS DEPARTMENT:
Under the Supervision of W. JAMES.

CONTENTS

	PAGE
Unity among Transmitters - - - - -	608
KDKA: Relaying the American Broadcasting. By W. J. Brown - - - - -	609
Low Capacity Inductance Coils. By F. H. Haynes -	613
The Three-Electrode Valve (<i>concluded</i>). By W. Sydney Barrell - - - - -	617
The Importance of the Amateur. By Dr. W. H. Eccles, F.R.S. - - - - -	620
Resistance, Choke, or Transformer L.F. Couplings? (<i>concluded</i>). By W. James - - - - -	624
Around the Wireless World - - - - -	627
A Visit to the Sterling Works - - - - -	629
Patent Abstracts - - - - -	631
With the Societies - - - - -	632
Calls Heard - - - - -	634
Questions and Answers - - - - -	635

THE EDITOR will be glad to consider articles and illustrations dealing with subjects within the scope of the Journal. Illustrations should preferably be confined to photographs and rough drawings. The greatest care will be taken to return all illustrations and manuscripts not required for publication if these are accompanied by stamps to pay return postage. All manuscripts and illustrations are sent at the Author's risk and the Editor cannot accept responsibility for their safe custody or return. Contributions should be addressed to the Editor, "The Wireless World and Radio Review," 12 and 13, Henrietta Street, Strand, London, W.C.2

SUBSCRIPTION RATES:

20s. per annum, post free. Single copies 4d. each or post free 5d. Registered at the G.P.O. for transmission by Magazine Post to Canada and Newfoundland.

As many of the circuits and apparatus described in these pages are covered by patents, readers are advised, before making use of them, to satisfy themselves that they would not be infringing patents.



EDITORIAL AND PUBLISHING OFFICES:

12 and 13 Henrietta Street,
Strand, London, W.C.2.
Telephone: Gerrard 2807-9.

ADVERTISEMENT MANAGERS:

Bertram Day and Co., Ltd.,
9 & 10 Charing Cross, S.W.1
Telephone: Gerrard 8063-8.

UNITY AMONG THE TRANSMITTERS.

By THE EDITOR.

ON Friday, February 1st, there took place a meeting of amateur interest which marks an important step forward in the right direction, and a decision was arrived at which promises far-reaching effects. The meeting referred to was an Extraordinary Meeting of the Radio Transmitters' Society, and the agenda was the consideration of amalgamation of that Society with the Transmitter and Relay Section of the Radio Society of Great Britain.

The meeting adopted the resolution almost unanimously, and there is little reason to doubt that amalgamation between the transmitting interests of the two Societies is to become an accomplished fact.

The policy of the Radio Society has always been, we believe, that of encouraging unity amongst amateurs and experimenters primarily with the object of strengthening their position as an important section of the users of wireless. To everyone who has at heart the interests of the amateur and experimenter it must be quite apparent that in unity alone lies hope of strength and permanent recognition by the public and by the authorities controlling the use of wireless by various interested parties.

The direct result of this amalgamation will be to strengthen enormously the position of the amateur, and particularly the transmitting amateur, who is naturally in a minority. Beyond this the influence is bound to be felt through the example which it sets to other Societies and individuals to give the strength of their support to any satisfactory steps which may be taken towards unity of purpose in amateur policy. The very fact that differences of opinion did formerly exist between many members of the Radio Transmitters' Society and the Radio Society of Great Britain, only serves to reflect more credit on the action of these two bodies in sinking minor differences in recognition of the outstanding importance of avoiding any split in the amateur ranks. Now that amalgamation is practically an accomplished fact, one can review the situation more freely.

We believe that it has been an advantage to the amateur community, and to the transmitters in particular, that the Radio Transmitters' Society was formed, because it has undoubtedly stimulated both Societies to take a keener interest in matters affecting the status of the transmitter, and healthy rivalry is essential to progress, providing it does not develop into definite antagonism. Fortunately, in this case, neither Society was antagonised, ample proof of which is given by the fact that the present amalgamation has come about.

Our own policy has always been to emphasise the desirability of unity on all matters affecting the amateur's position, so that where united effort is called for, every individual and every party can give its support to strengthen the position of the amateur community as a whole.

Those who have read our editorial which appeared in the issue of August 1st, 1923, will be familiar with our views as to the position of the amateur. Perhaps in conclusion one might quote from that page:—

"Instead of each amateur or group of amateurs having at heart, first of all, the welfare of the amateurs as a whole, we find on every side politics in wireless which lead to petty jealousy between individuals and between one amateur society and another. Criticism is resorted to far more readily than a helping hand, with the result that amateurs are drifting further and further apart instead of strengthening the bonds of unity.

"If it is our honest desire to help to strengthen the amateur's position, then it is clearly our duty to put our shoulders to the wheel and help instead of standing passively aside to criticise others, who, though we need not wholeheartedly endorse their every action, are nevertheless honestly endeavouring each one 'to do his bit.'"

KDKA

EXPERIMENTAL WORK ON THE RELAYING OF AMERICAN BROADCASTING.

By W. J. BROWN, B.Sc.,

Research Department, Metropolitan-Vickers Electrical Co.

IN view of the interest which has been shown in the recent relaying of the American Broadcasting station **KDKA** in this country, an account of the experimental work which made this possible should be of interest to readers of *The*

are the result of a tremendous amount of preliminary experimental work, all of which has been carried out by the Westinghouse Electric and Manufacturing Company of East Pittsburg, Pennsylvania, U.S.A., in co-operation with the Metropolitan-

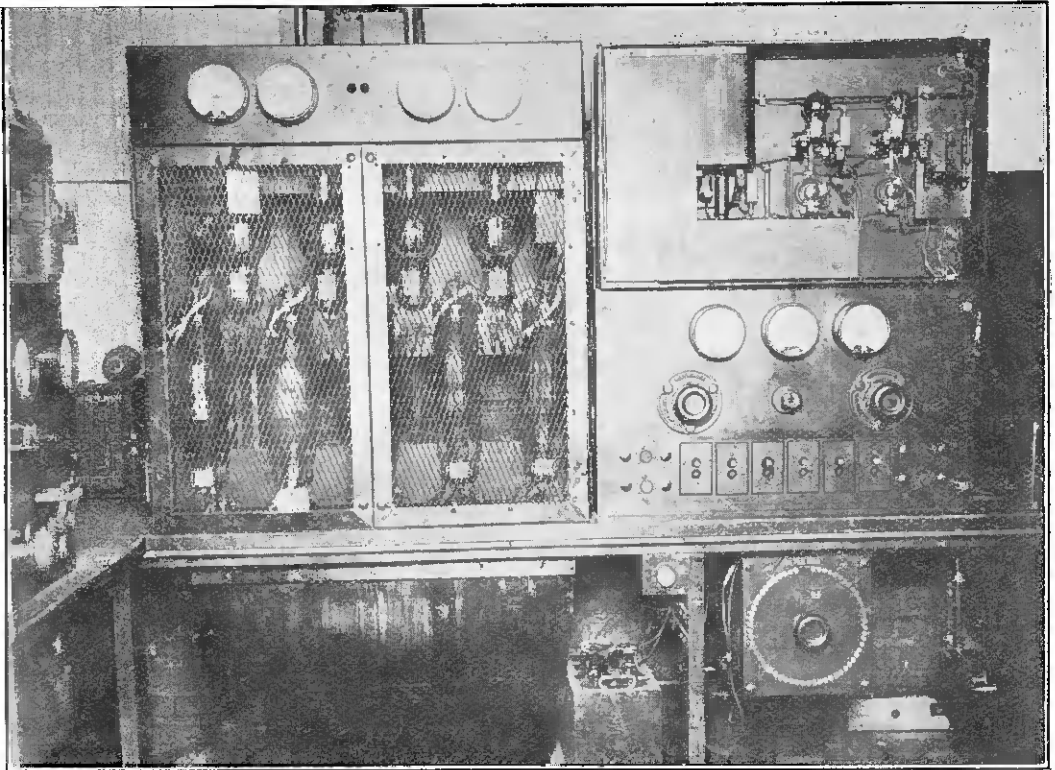

*The Transmitter at KDKA, East Pittsburg, Pennsylvania, U.S.A.
An aerial energy of 7 kW., corresponding to an input of 30 kW., is obtainable.*

Wireless World and Radio Review. As is well known, the **KDKA** transmissions have been made on a wavelength of 100 metres. It is not, however, so well known that they

Vickers Electrical Company, of Trafford Park, Manchester. A great deal of work has been carried out by the two companies concerned, with the sole object of making

possible the relaying of American programmes in this country.

In September, 1923, the joint investigation commenced. The Westinghouse Company installed at East Pittsburg a 100 metre transmitter, while the Metropolitan-Vickers Company equipped their station at Altrincham, Cheshire, with the necessary receiving apparatus. At first the transmissions were of comparatively low power, but nevertheless good reception took place from time to time. As compared with the 300-500 metre American broadcasting, reception was indeed very satisfactory. Much greater constancy of signal strength was observed, both from day to day, and also from hour to hour during the night. In particular it was found possible to receive the 100 metre signals as early as 10 or 11 o'clock at night, while of course the 300-500 metre signals do not as a rule start coming through until about one or two o'clock in the morning. Great improvements were also obtained in the amount of interference from spark stations, "mush" and static.

Results being so promising, the Westinghouse Company installed a high-power 100 metre transmitter especially for this transatlantic work.

The Westinghouse Company's high-power 100 metre set is capable of delivering 7 kilowatts to the antenna, corresponding to an input of nearly 30 kilowatts. To deal with this large power, specially designed valves are used, these being fitted with a water-cooling system so that high values of anode dissipation can be employed.

Every possible precaution has been taken to avoid slight changes in wavelength, which in conjunction with varying propagation conditions would give rise to "night distortion." For this reason the antenna system is of extreme rigidity, being composed largely of copper tubing. The high-frequency connections on the transmitter are also designed for maximum rigidity, while the necessary inductances are wound on rigid formers. As a further precaution the whole of the high-frequency section of the transmitter is mounted in a framework suspended by springs.

The wavelength at present in use is 326 metres, and this transmission has been heard, also that on 100 metres, by amateurs in this country. The 100 metre transmissions to the Metropolitan Vickers Company are

frequently carried out at the same time as the normal 326 metre broadcasting, the same microphone and initial stages of amplification being used for both transmissions. The 326 metre transmitter is located at the top of a nine-storey building, 115 feet above ground level at the Company's works at East Pittsburg, Pa. The antenna consists of six wires, 190 feet in length, supported by 20-ft. spreaders, and is suspended 210 feet above the ground. A counterpoise is suspended 110 feet beneath the antenna, this being a duplicate of the antenna itself.

The main studio is situated about half a mile away from the transmitter. In the city, 14 miles distant, are two more stations, one being the studio of the *Pittsburg Post*. Land line transmissions form an important feature in the Pittsburg transmissions. **KDKA** has 45 permanent land lines, taking in every church, theatre, public hall or auditorium of any pretensions whatever in that section of Pennsylvania. The total area covered by the land line system amounts to nearly 250 square miles.

Returning now to the 100 metre transmissions, it was found that, notwithstanding the elaborate precautions which were taken to avoid wavelength variations, serious night distortion frequently took place. On many occasions the speech was very loud but was rendered quite unintelligible by this distortion. Experimental work was therefore continued with renewed vigour with a view to eliminating the trouble. Test transmissions employing special forms of modulation were carried out after the normal American broadcasting hours, usually between 4 or 5 a.m., and 7 a.m., with a view to analysing the effect. It was found by measurements made at the receiving station of the Metropolitan-Vickers Company, situated at Altrincham, that the wavelength was varying slightly according to certain definite laws. Following each test a report was immediately cabled to Pittsburg and the necessary adjustments for the following mornings test. Eventually a sufficient improvement in quality was obtained and on December 27th some excellent transmission gave good reception. Unfortunately it was impossible to relay this since the British Broadcasting stations did not close down till midnight, by which time the Westinghouse Company had closed down their 100 metre transmitter for further

adjustments. However, on the following night all listeners in Great Britain were able to listen to a fairly successful relay of Pittsburg.

Immediately following the first re-radiation of **KDKA**, the Metropolitan-Vickers Company conducted a series of relaying tests with a view to gauging the success of the method, and it is proposed here to indicate briefly the results achieved during this period.

or three occasions relaying commenced shortly after 11 p.m. The best relaying was, however, carried out in the early hours of the morning, between 4 a.m. and 7 a.m. The results obtained at these hours were in fact sometimes extraordinarily good, approaching perfection almost as closely as do the straightforward broadcasting transmissions. On one night a complete evening programme was relayed,

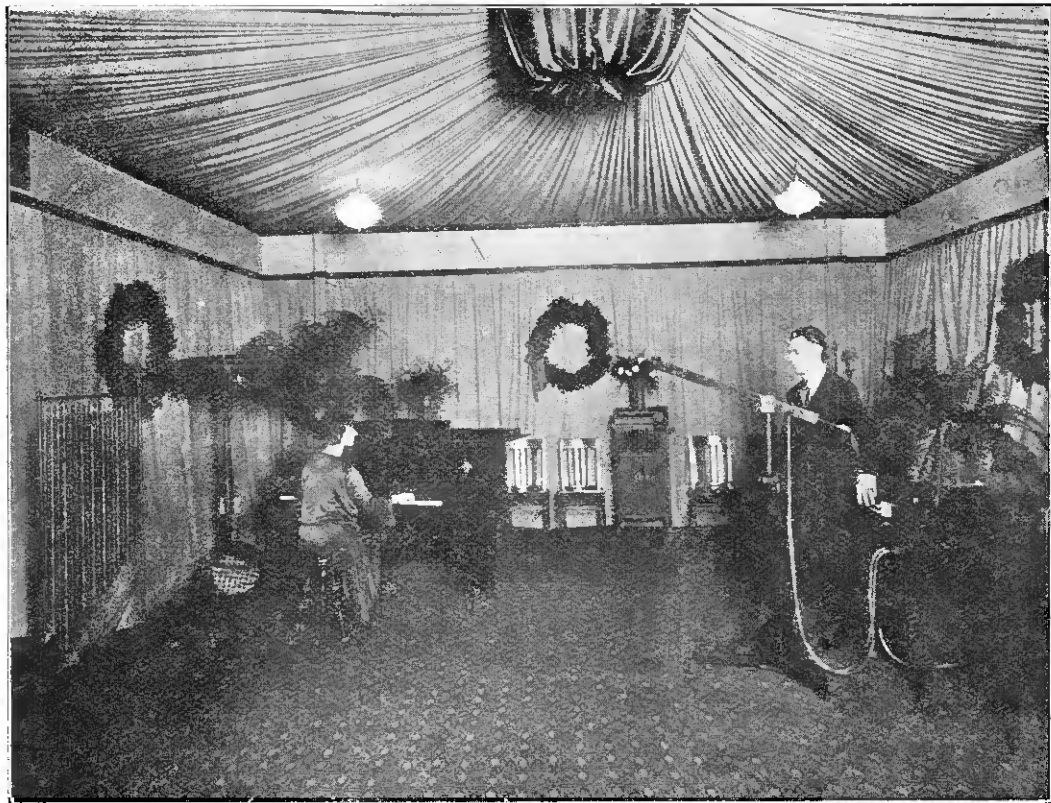

The Studio at KDKA.

During the period of seven or eight days relaying was carried out for an aggregate time of eighteen hours. A very large number of reports were received from listeners, many of them coming from the Continent, the re-radiation being distinctly heard as far off as Switzerland. This is considered a very creditable performance, since the power input to the transmitter at **2 AC** is about one half the average power of an ordinary broadcasting station. On two

commencing with some items by the Westinghouse band at 11.20 p.m., and finishing with the relaying of the Arlington time signals at 3 p.m.

Comparing these results with those which might have been obtained using the normal 300-500 metre waveband, it could fairly safely be assumed that reception on the latter waveband would not have been good enough for relaying more than two or three hours a week. Also such relaying could not

have started until well after midnight, which alone is sufficient to render the 300-500 metre transmission useless for regular relaying purposes in Great Britain.

It should be understood, of course, that even the 100 metre signals do not yet give

possibilities of further improvements which are almost certain to take place we may look forward to a day, probably not very far distant, when the British public as a whole will be able to listen to American "late news," to hear famous American

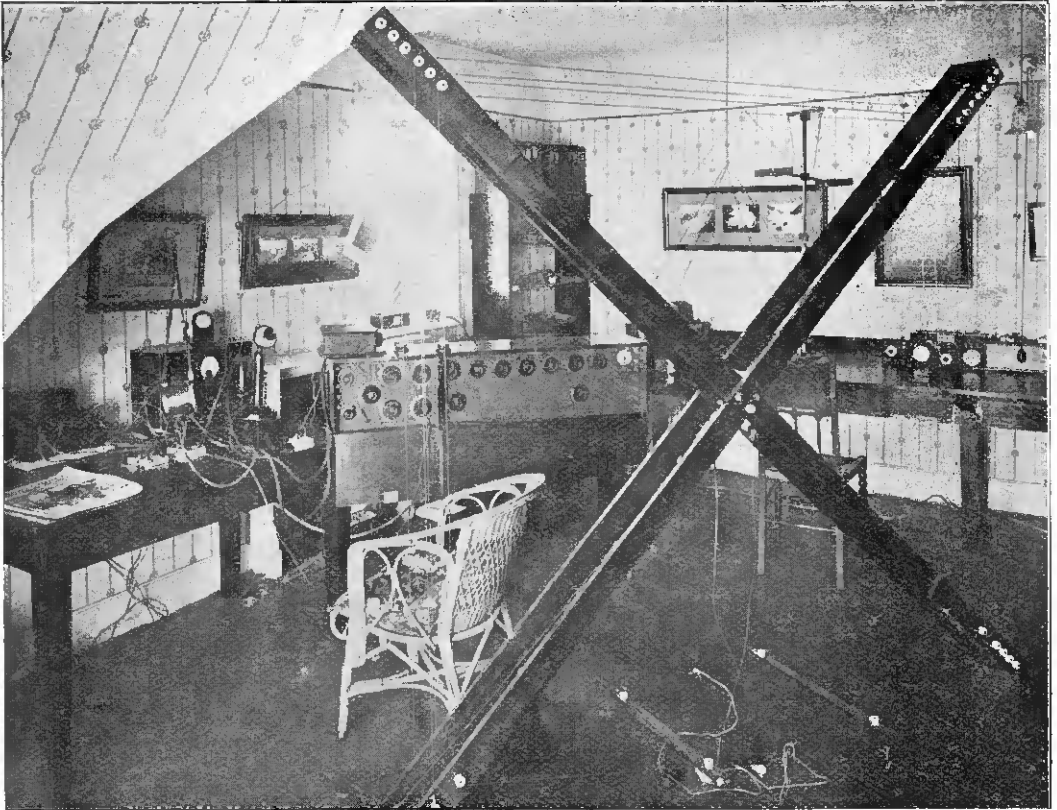

The experimental receiving equipment of 2 AC near Manchester.

sufficiently good reception for relaying to take place as a regular thing, but on the other hand it may be claimed that these 100 metre experiments have considerably increased the chances of relaying. With the

speakers, and to enjoy American entertainments. There is no need here to enlarge upon the value of these experiments which may ultimately lead to the establishment of such a service.

CALIBRATION SIGNALS FROM 6 XX.

In the early morning of Thursday, February 14th, a series of calibration signals will be transmitted from 6 XX, the station of the Radio Society of Great Britain. The times of transmission of these signals (a succession of V's) are as follows: 2400 to 0005, on about 220 metres; 0010 to 0015, on about 180 metres; 0020 to 0025, on about 150 metres; 0030 to 0035, on about 120 metres.

At 0040 a message will be transmitted.

At about 0045 a series of code words will be sent on about 180 metres, with gradually diminishing antenna current. A record of the antenna current corresponding to each code word will be kept and published later. Everyone who notes down the last code word he is able to receive will thereby obtain an indication of the sensitiveness of his apparatus, and of the effect of his geographical position.

LOW CAPACITY INDUCTANCE COILS.

SOME NEW COILS FOR SHORT WAVE RECEPTION.

By F. H. HAYNES.

CONSIDERABLE attention is now being given to reception on wavelengths of the order of 80 to 220 metres, which necessitates the introduction of specially designed circuits and modifications in the construction of the receiving apparatus. Foremost among the difficulties which present themselves is that of building tuning coils possessing a minimum of distributed capacity, a property which becomes most desirable when

making use of partially aperiodic windings in aerial and high frequency amplifying circuits.

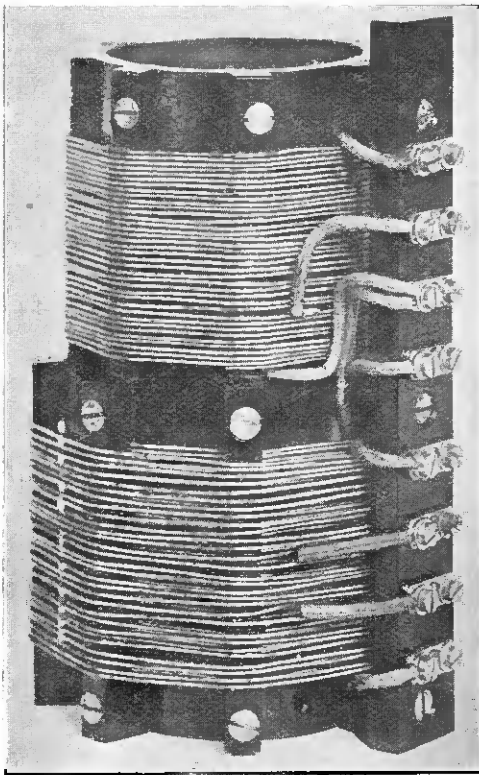

Fig. 1. A high frequency transformer suitable for use in aerial and closed circuits or intervalve H.F. coupling in a short wave receiver. The partially aperiodic primary is the smaller outside winding.

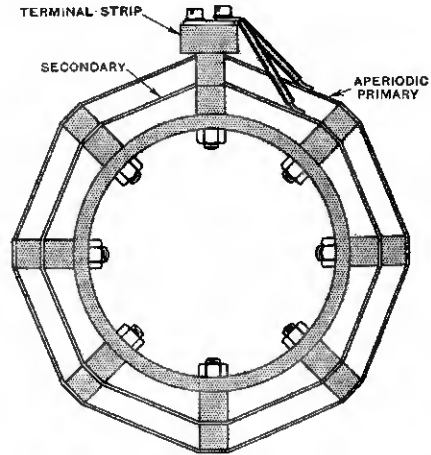

Fig. 2. End view of H.F. transformer, showing the method of supporting the windings away from the former. The turns of the windings are spaced by running on two wires together and removing one when the requisite number of turns is complete.

An air spaced self-supporting coil is the aim in short wave inductance design, and the accompanying illustrations show coils approaching this requirement. As the resistance increases with the frequency, comparatively large gauge wire with ample surface area is desirable, which is also a requirement with any self-supporting coil in order that it may have the requisite mechanical strength.

In an early attempt to build a short wave aerial circuit transformer the arrangement shown in Figs. 1 and 2 was adopted. The secondary circuit is wound upon eight narrow ebonite strips which are supported around an ebonite cylinder, whilst the primary is carried upon a second layer of strips resting on those which support the secondary (Fig. 3). Slots are made in the under faces

of the strips which take the primary in order to give clearance to the secondary winding. When winding on the secondary, thread may be run on with the insulated wire in order to slightly space the turns, and removed when the winding is completed. Similarly, when winding the primary a pair of wires paid off from two reels are wound on together, and by removing one of these wires even spacing results.

Something is gained by way of reduced self-capacity by this method of construction, and it is certainly more efficient than an inductance wound upon the face of a cylindrical former, though it



Fig. 3. Ebonite spacing strips. A hollow on the underside gives clearance to the windings.

still has the disadvantage that it is difficult to make a number of soldered connections for tapping out the winding and, moreover, as the strips which support the outside winding are themselves supported by those carrying the inside winding, it is not possible to vary the coupling between the primary and secondary inductances once they are in position.

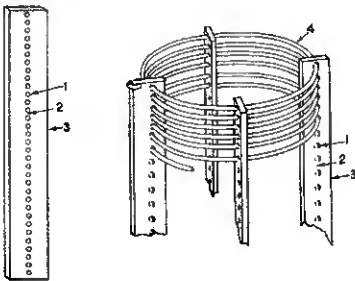

Fig. 4. Air spaced inductance with turns supported by ebonite strips. The holes (1) are of a size to allow the wire to slide freely through them. Spacing (2) may be as small as possible, but the holes must not be so close together as to weaken the strip or to cause a breaking away between the holes.

In overcoming these defects the coils shown in Figs. 4, 6, 7 and 9 were evolved. Ebonite strips having regularly spaced holes support the turns. A convenient size for these strips is $\frac{1}{2}$ in. in width by $\frac{3}{16}$ in. in thickness. Some difficulty was experienced in accurately setting out the positions for the holes. It can be achieved quite well, of

course, with dividers, but a quicker way is to coat the surface of the ebonite strip with a layer of wax and then draw along it a

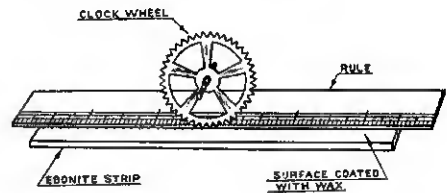

Fig. 5. A simple method of setting out evenly spaced positions for the holes.

revolving clock wheel having sharply-pointed teeth, and guided by a straight edge. All of the dots thus made must be carefully centre punched, remembering that one slightly out of position may cause a hole to break into its neighbour or a turn of the finished inductance to appear conspicuously mis-spaced. The size of the hole depends upon the gauge of the wire to be used, the diameter into which it is to be coiled, and also, as will be seen later, upon the length of the coil. It will not be necessary to build a coil of this sort less than 2 ins. in diameter,

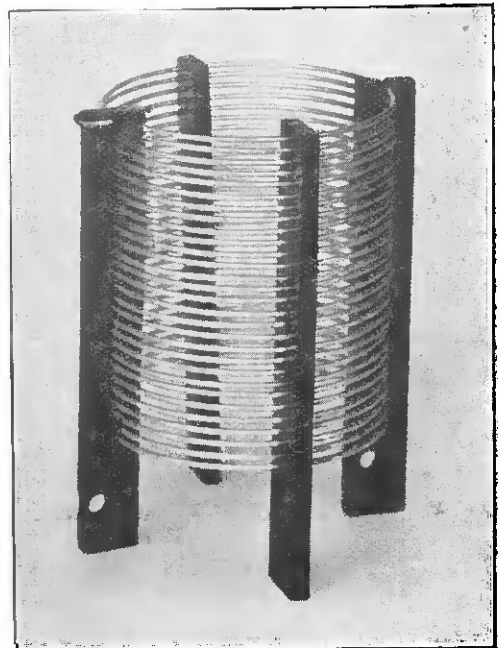

Fig. 6. The completed coil suitable for short wave tuning.

and thus the holes need not be unduly large to allow for any great curvature. On the other hand, if the number of turns exceeds about 40, difficulty is experienced in getting the turns on to the strips, and the size of the hole must be slightly greater to reduce the friction between the strips

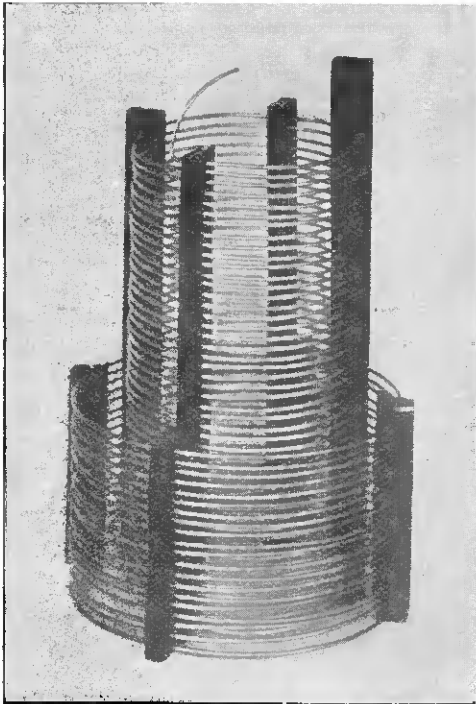

Fig. 7. Short wave H.F. transformer. The primary is 34" and the secondary 24".

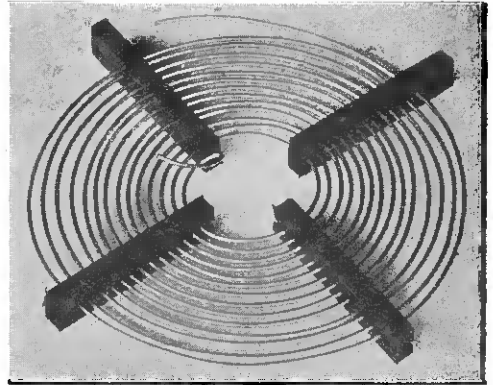

Fig. 9. A spiral inductance supported by similar ebonite strips as employed in building the solenoids.

and shaping, the coil holes should be $\frac{3}{32}$ in. The spacing between the holes varies according to the gauge of the wire, and with No. 18 S.W.G. may be $\frac{3}{32}$ ins. from centre to centre, while with Nos. 16 and 20 spacings of $\frac{7}{64}$ ins. and $\frac{5}{64}$ ins. respectively are suitable. Having drilled a strip which is to form one of four to support a coil, it is essential for the holes in the other three strips to be identically spaced, repeating any small discrepancies that may have occurred when making the first strip. This can be done by using the first strip as a template for the others, pinning it on to the strip to be drilled with pieces of No. 16 S.W.G. tinned copper wire driven into $\frac{1}{16}$ in. holes. Holes are continued to within $\frac{1}{16}$ in. of the ends of the strips.

as they slide round on the turns of wire. Holes made with a $\frac{5}{64}$ in. drill will give easy clearance for No. 18 S.W.G. for moderately long solenoids. For shorter coils, $\frac{1}{16}$ in. holes are suitable, whilst in the case of the spiral where the curvature at the centre is greater than with the solenoid, and difficulties are experienced in flattening



Fig. 10. Slotted washer for spacing winding cheeks. Two wires are wound on together to give a spaced spiral formation. The slots in the washer prevent irregular bends on the inner turns.

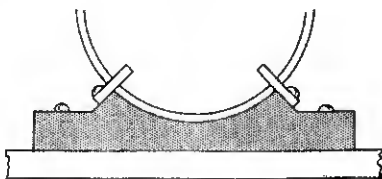

Fig. 8. Suitable mounting piece.

The method of building the coil is readily apparent. A winding is made on a suitable sized former with hard-drawn copper (not bronze, which is too springy) wire. Ebonite tube makes a suitable former. It is advisable to previously straighten the wire by paying out the required length and stretching it, for the slightest bend in the wire will render the building of the coil difficult. This preliminary winding is made with turns touching,

keeping a good pull on the wire and taking care not to allow it to run slack until the coil is finished. Wearing a glove on the right hand will facilitate obtaining a secure grip on the wire. The diameter of the former should be a little less than the required diameter of the coil to allow for a slight enlargement due to the springing open of the wire when it is removed from the former. It is now only necessary to thread one end of the wire on to the strips and proceed to push them round the winding engaging the beginning end in one more hole on every revolution. The turns still disengaged should be supported with the finger and thumb of the left hand, the finger being inside the coil, and at the same time gripping and guiding the turns on to which the strips are advancing. Any tendency for the coil to become out of shape should be checked as the making is proceeded with, and not left till the end, for by keeping the sides quite parallel it is easier to rotate the strips on the wire.

For producing a variable coupling on to solenoid wound coils, spiral inductances are required. A number of spiral inductances, also, when assembled together, produce a tuning coil occupying less space than the solenoid. To shape the wire for building a spiral (Fig. 9) it is necessary to make use of two plates of ebonite spaced by a washer having a thickness equal to the

gauge of the wire. Two holes are made in one of the ebonite plates through which the commencing ends of a pair of wires are passed. Two small slots are made in opposite sides of the spacing washer as shown in Fig. 10 to prevent bumps appearing in the beginning turns of the winding. The two wires, previously straightened by stretching, are wound on to the requisite number of turns, and then by the removal of the bolt or screw which holds the plates together, the two spirals thus produced can be readily separated. The spiral must be kept quite flat as the strips are threaded on and should it have a tendency to close up in a basket fashion the outside turns must be made looser by unthreading.

A little thick shellac varnish applied with a brush along the strips will hold them in position on the turns of the wire. Alternatively ebonite end mounting pieces may be attached to hold the strips in position.

The coils may be mounted by ebonite pieces cut from $\frac{5}{16}$ in. ebonite sheet to the shape shown in Fig. 8.

This method of producing inductances of high efficiency carries with it the advantage that tappings need not be made until the wiring-up stage of the instrument is reached, and the tapping points can easily be readjusted after tests have been made with the completed instrument of which they may form part.

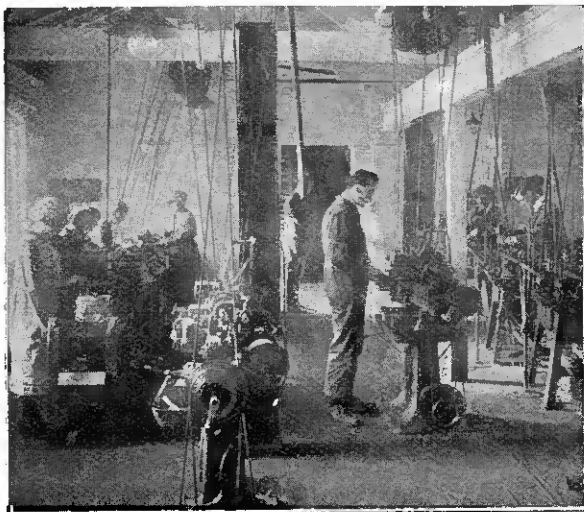

THE FORMO COMPANY'S WORKS.

Our photograph depicts one of the automatic machine shops in the works of the Formo Company, which are situated at Cricklewood. This portion of the factory is concerned with the manufacture of the screws, nuts, terminals, and condenser and rheostat spindles incorporated in the Formo wireless products.

On the left will be seen the screw slotting machines.

THE THREE-ELECTRODE VALVE.

By W. SYDNEY BARRELL.

(Concluded from page 594 of previous issue).

ACTION OF THE GRID.

THE curve of Fig. 4* indicates the variation in the anode current of a Marconi-Osram "R" valve caused by varying the grid potential. We see that as the negative potential on the grid is reduced, the current to the anode increases, slowly at first, but afterwards much more rapidly, until a certain point is reached where saturation begins, that is, as already explained, when the electrons are being drawn away from the filament as fast as they are being emitted. This

curve, it will be noticed, is very similar to the anode current-anode voltage characteristic of the two-electrode valve already discussed. There is a difference, however, that in the present case the anode current is limited not only by the space charge and fall of potential along the filament, but also by the grid. For this reason for the same anode potential the current in the three-electrode valve will be smaller than in the diode. Fig. 4 further shows that, starting with the grid at zero potential, a negative charge imparted to it decreases the anode current, while the application of a positive charge increases the anode current. This is the fundamental action of the valve whether employed as a detector or as an amplifier.

Now before the saturation current is reached the attractive power drawing the electrons across to the anode is proportional to some power of a voltage, and in the case of the diode, this is the anode voltage. When dealing with the triode, however, this voltage is no longer solely the anode voltage. There are now two voltages acting on the emitted electrons, one due to the anode and the other due to the grid. This effective voltage as it may be termed can be expressed as $\left(\frac{E_p}{K} + E_g\right)$

where E_p and E_g are respectively the anode and grid voltages and K is a constant. $\frac{E_p}{K}$, as we have already noted, represents the lines of force proceeding from the anode that reach *through* the grid and therefore tends to draw the electrons through the grid and by varying the potential of the grid (E_g) the field between grid and filament is varied, but whether electrons

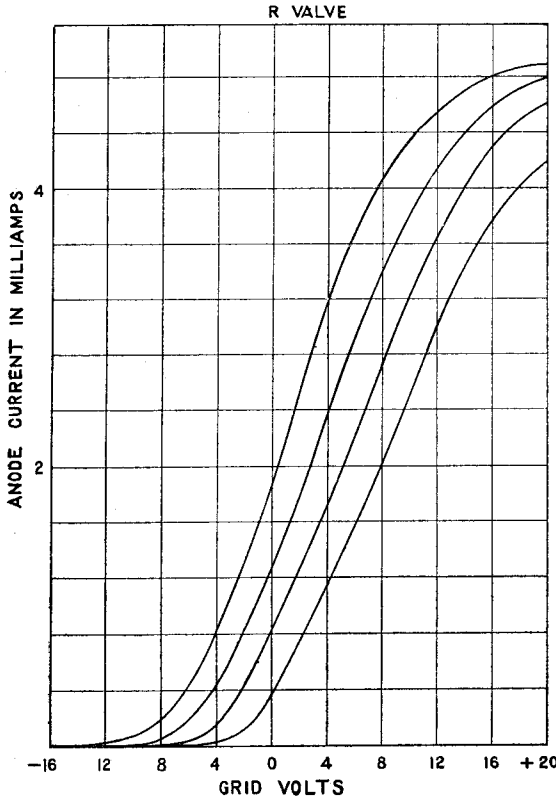

Fig. 5. Characteristic curves of an "R" type valve for several anode voltages. See also Fig. 4.

*February 6th, page 594.

flow away from the filament or not will depend upon the relative values of $\frac{E_p}{K}$ and E_g .

MAGNIFICATION FACTOR.

The factor K appearing above and already referred to several times, is one of, if not the most important factors in the three electrode valve and plays an important part in all its operations. It is known as the "magnification factor," and may be defined as the ratio of the change in anode volts to the change in grid volts to give the same variation in anode current; or in another way it is that voltage which, if applied to the anode, produces the same change in anode current as does one volt applied to the grid.

The following simple experiment will demonstrate what is meant by magnification.

Let us arrange a valve as shown in Fig. 6, the filament and anode voltages being adjusted to the normal operating values.

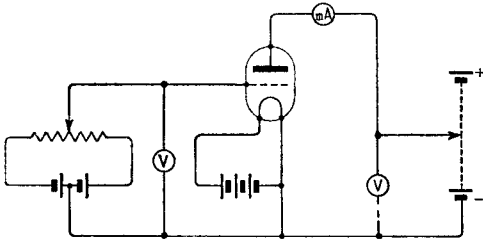

Fig. 6.

Then starting with say zero grid volts, a certain current will be flowing in the anode circuit, its value being indicated by the anode milliammeter mA; carefully note this reading. Now increase the anode voltage by, say, 10 volts, the grid voltage remaining zero. The anode current will now have increased, but if we apply a suitable grid potential the anode current may be restored to its original value. Suppose the anode current to be restored to its first value by putting -1 volt on the grid. What does this show? It shows, of course, that one volt applied to the grid has the same effect on the change in anode current as ten volts applied directly to the anode, or, in other words, the application of one volt on the grid is equivalent to ten on the anode, that is the magnification factor (K) of the particular valve used is 10.

It will be remembered that this factor K appeared in the "leakage field" relation which therefore indicates that the magnification factor of a valve is a function of its structure. For example, it can be shown to vary inversely as the spacing between the grid wires, that is, the greater the spacing the smaller the magnification factor. It also varies directly as the distance grid to plate and so on.

There seems to be no really reliable theoretical equation for calculating the magnification factor, and the error is greater in valves having a high value of " K ." This is mainly due to the fact that the formulæ are based on the assumption that the diameter of the grid wire is very small compared to the spacing, and further, no account is taken of support wires and the like which for mechanical reasons are essential to the construction. It is therefore usual to employ either empirical formulæ or to measure the magnification factor by one of the several known methods, such as for example that explained above.

ANODE IMPEDANCE.

The anode impedance is another important factor in the valve, and is due to the work which the electrons must do in moving across the space from the filament to the anode. It is given by the change in anode voltage divided by the change in anode current at the same grid voltage and it can be measured from the curves of Fig. 5. For example, at zero grid volts the anode current, when the anode voltage is 90, is, as shown by the top curve in the figure, to be 1.83 milliamperes. At the same grid potential, but with the anode voltage reduced to 70, the anode current is 1.24 milliamperes. (See 70-volt curve in the figure.) Thus for a change of 20 volts (90-70) on the anode the anode current changes by 0.59 milliamperes (1.83-1.24), and therefore the anode impedance is given by $\frac{20}{0.59} \times 10^3$ (multiply by 1,000 because the current is in milliamperes), which is equal to 33950 ohms. Care must be taken to differentiate between the impedance and D.C. resistance, the latter being, of course, simply the plate voltage divided by the plate current actually flowing.

EFFECT OF ANODE VOLTAGE ON ANODE CURRENT CURVES.

Several characteristic curves for a Marconi Osram "R" valve are shown in Fig. 5.

the same valve being used as that which gave the curve of Fig. 4. In all cases the filament has been maintained at normal brilliancy and therefore the only difference in the conditions under which the valve worked was the value of anode voltage which is indicated on the curve to which it refers. The method of obtaining these curves is exactly as has already been described, and the process is simply one of repetition, but with a different anode voltage each time.

It will be observed that the effect of changing the anode voltage has been to alter the *position* of the whole curve on the diagram without altering its *shape*, the effect of applying a higher potential to the plate moving the curve bodily to the left and *vice versa*. Furthermore it will be seen that for any grid potential the anode current is increased by an increase in anode voltage, provided, of course, saturation has not been reached.

Each of these curves shows how the anode current varies when the anode voltage is kept constant and the grid potential is varied.

Except for this lateral shift of the characteristic the value of the anode potential has practically no other effect on the curve shape.

EFFECT OF FILAMENT BRILLIANCY.

The effect of filament brilliancy on the anode has already been discussed in relation to the two-electrode valve, and in Fig. 7 is shown three anode current-grid volts characteristics of a Q.X. receiving valve, each taken with the filament at a different temperature, the anode volts being maintained constant for all three curves.

The results obtained are, in the light of our previous knowledge, to be expected, for we know that the saturation current decreases with decrease of filament temperature and *vice versa*. There are, however, certain other differences such as the steepness of the curves, which is seen to vary directly as the filament temperature.

GRID CURRENT.

All the curves that we have so far shown represent the current to the anode, which may or may not be the total current leaving the filament. As long as the grid is maintained at a potential negative to all parts of the filament no electrons will be attracted

to it, but when, on the other hand, the grid is given a positive potential it will attract a certain number to itself, the rest being drawn through the grid spaces, and thus a current will be established in the grid as well as in the anode circuits.

When the grid potential is positive the proportion of the electrons going to and through the grid will depend upon several factors such as the mesh of the grid (*i.e.*, whether open or close), the diameter of the wire of which the grid is made, and the relative

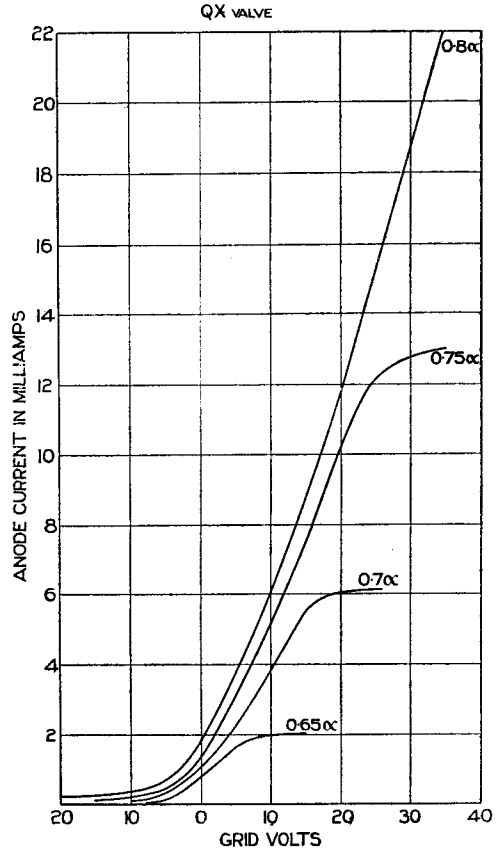

Fig. 7.

values of anode and grid voltages. For example, if the anode voltage is high compared to the grid voltage comparatively few electrons will reach the grid and the grid current will be small.

When, however, the grid potential is negative, practically all the electrons which are drawn away from the space surrounding the filament go to the anode, those reaching the grid being very few indeed.

THE IMPORTANCE OF THE AMATEUR

An address to the Radio Society of Great Britain, delivered by the President, Dr. W. H. Eccles, F.R.S., on January 23rd, 1924.

The Objects of this Society.

I might remind you of what you all know, that the Radio Society of Great Britain exists for the benefit of those who practice or study wireless for its own sake, whether they happen or not to make any money by part of their work in the subject. Meetings are held for the inter-communication of scientific information, for mutual instruction and assistance, for bringing together people interested in wireless, and for the circulation of ideas of all sorts by all feasible means. During the past few years the influence of the Society has rapidly extended as the result of the enormous growth of public interest in wireless, and also as a result of the policy of affiliating societies scattered throughout the country; and thus the Radio Society has found itself becoming, almost in spite of itself, the centre of the amateur movement of the whole country. Therefore, in addition to the functions which I have just enumerated, the Society is confronted with the task of holding the amateur movement together in the most difficult times this movement has yet experienced. It is also faced with the task of watching political and other circumstances that are likely to re-act upon the amateur. Almost simultaneously with these duties there came the need for taking over the management of an ambitious programme of work projected by the British Wireless Relay League and for helping the inauguration of the Schools movement. The former piece of work was separated off as the Transmitter and Relay Section, and the latter has become the Schools Radio Society and holds the rank of a section of the Society as defined by the new rules. Both these new burdens on the Society are nation wide in their scope, and meet needs that were strongly felt.

In carrying out these tasks the Society finds itself in the midst of two great popular currents which affect its future very deeply. Firstly, there is the increasing use of wireless for public and commercial message services and for the distribution of entertainment by the broadcast. The latter, of course, is a newcomer, and yet it overwhelms the older use enormously. Besides this, there is the increased public interest in wireless science chiefly as the result of the arrival of the broadcast. The former current is making the spectrum of useable wavelengths more and more tightly packed, leaving less room for each user, including the amateur. The second current, *i.e.*, the increasing popular interest in wireless generally, is bringing more and more persons into the ranks of the student and the experimenter. Many a holder of a constructor's licence is turning his attention to a study of the subject and is already a recruit, of greater or less merit as the case may be, to the ranks of the amateurs. Thus we have the rather unpleasant result that there are more amateurs than ever before, and they have to be accommodated inside a narrower region of the spectrum than would have been available aforesaid.

Two Big Problems.

It seems to me that in consequence of these new circumstances there are two big problems immediately in front of the Society. One is to ensure that the amateur and student of wireless telegraphy obtains his rightful share of the spectrum in accordance with his relative importance among all the other users of wireless. The other big job for the Society is to help in the establishment of order among the users of wavelengths appropriated to the amateur transmitters and the broadcast listeners. Regarding the rights of amateurs to bands of wavelengths, there are many people, I believe, who say that amateurs have no right at all to any wavelengths, presumably because they are not making money out of it. This is a nation of shopkeepers, and this attitude of mind is to be expected from such a nation, but it is the duty of this Society to show the nation that the work of the experimenter is worthy of encouragement from the point of view of the long-sighted shopkeeper and the industrialist.

The Two Types of Wireless Amateur.

There are two main types, it seems to me, of wireless amateur. Firstly, there is the man who wants to construct apparatus and see it work; and, secondly, there is the man who wants to experiment in and practice the art of communication by wireless. The first type of man is at home with many other mechanical and electrical hobbies, and I addressed this Society last autumn in the endeavour to show that he was, in virtue of his hobby, a very useful member of the community. The second type of amateur follows his hobby because he simply dotes upon the doing of it. He cannot explain his affection for it any more than another man can explain why he keeps rabbits, for instance, or still another man can explain why he goes fishing. I confess that I myself cannot conceive why anybody does either of these latter things unless it be that the men in question consider rabbits or fish to be delectable articles of food. I am always particularly perplexed by the angler, though I respect his, to me, unfathomable motives; but I think I can sympathise with and understand the passion of the wireless amateur who goes fishing in the electrical ocean, hoping to draw a congenial spirit out of the unknown depths. This type of amateur sits in his laboratory and sends out a little message, baited with 10 watts, say, and then listens with beating heart for a response from the void. Usually his cry is in vain. He draws a blank. But sometimes he hears, mixed up with his heart throbs, a reply from another "brass pounder" calling him by his sign letters. What a thrill! And when the response is faint and seems to come from very far away, with what excitement does he struggle to maintain touch? I can imagine the anxiety and enthusiasm with which he deciphers the Morse, say, of an American amateur, is overpowering;

and I can imagine the despair with which he battles against the demons of fading and interference. I can feel it is a very exciting and thrilling sport, but it is more than that. It teaches a wonderful skill in manipulation, and it screws up the efficiency of the apparatus and the man to the highest pitch. The DX man, striving to get across enormous distances with minute power, becomes far more expert than the ordinary professional operator.

Amateurs and the War.

I remember very well that men of this type altered the whole standard of transatlantic reception during the war. After the United States came into the war the receiving stations on the Atlantic coast, particularly the large station at Otter Cliffs, which many of you have heard of, were manned by young fellows practised in DX work. They succeeded marvellously, and read a record number of words per day. At that time Lyons was enlarged by the addition of a bigger arc, and Bordeaux, just after the close of the war, was brought into operation with another arc, and these men succeeded so marvellously in receiving the messages transmitted that the Government experts of the United States came to the conclusion, and announced very emphatically, that at long last the Atlantic was conquered, and that it was possible to ensure a regular uninterrupted twenty-four hours service per day in summer and winter, without delays, by the aid of such transmitting stations as the arc station at Lyons. Then came demobilisation and the DX men went home from the Atlantic coast. Their 'phones were picked up by the orthodox operators, the standard of reception fell immediately, and so, as far as I know, has not yet risen to its former glory. It will not, I think, rise to the same height with the same apparatus again.

The Importance of DX Work.

As another example of the utility of this DX work, consider the recent results achieved by a small band of private workers who, during the past month or two, have been trying to find lanes under the Heavieside layer, across the Atlantic. You all know the success which has been attained with short wavelengths throughout an unexpected number of hours in the twenty-four. I do not doubt that if these amateurs had left the problem alone we should to-day be ignorant of its possibility. It might have been many years before these facts would have been revealed in the ordinary course of things. The feat is not an easy one, as is shown by the fact that if they could have done it, some of the commercial wireless companies would certainly have made very profitable advertisement out of it. Moreover, the Governments on both sides of the Atlantic maintain large staffs of men, some of whom have very little more to do than listen in to signals. I am thinking of the naval and military and air forces particularly, in France, in America and in this country. These facts escaped their notice and, indeed, would have been regarded as incredible.

From all this I deduce that in wireless, as in many other pursuits requiring concentration and skill, the best results are often achieved by men who are not brought up to work at it for a living.

This holds good in yachting, in cricket, in marksmanship and many other sports. It holds still further, in my opinion, in the sciences and in the applications of science; and especially in the scientific hobbies, including, of course, amateur wireless, which, in addition to its fascination as a sport, possesses also the qualities of immediate importance in commerce and of utility in national emergency. It is quite conceivable that these discoveries of the properties of short waves may be of great commercial service, and certainly might be of immense military significance in time of war.

The last time I addressed you—last autumn—I paid most attention to the merits of the class of wireless amateur who is fond of his hobby because he can make and work something, and I tried to show you that he deserved the support of every intelligent citizen, and certainly of this Society, which is largely constituted of him and by him. I said nothing of this other kind of man, however, partly because there was no time, and partly because it did not occur to me that such remarkable results could be achieved by him in the immediate future. I am therefore specialising on this other type of wireless man to-night in the hope of showing you that the "fisherman" type, if I may call him so, is worthy of his salt, worthy of our support and encouragement, and merits the granting of every possible facility that we can find for him.

Inexperienced Amateurs.

I have been speaking so far—both last autumn and this evening—of the best of the amateurs who form, I believe, the larger portion of the membership of this Society and the Affiliated Societies. But there are others, and many of these lack skill and produce considerable interference with military and naval services and sometimes with broadcasting services. Amongst these must be included the kind of amateur who uses 20 or 30 watts to establish communication between himself and a friend a mile away, and thereby agonises everyone within 20 miles. Then there is the amateur who blares forth, without provocation or excuse, recitatives from corrugated gramophone discs; there is the amateur who never listens in either before or after shooting his bolt; there is the man who specialises in apparatus comprising every possible error of design and who emits the broadest possible band of waves. Perhaps many of these sinners know not what they do; others there are who do know, I think, what they are doing and do it almost, one might say, of malice aforethought. Many of this class have no call sign, and other use fancy call signs, and there are others, again, who use other people's call signs, a tribe that is quite unlicensed. Besides these there are other nuisances, but I am going to refer to them a little later in another category.

Improper Use of Apparatus and Call Signs.

The state of affairs represented by what I have just said appears to be getting worse rather than better. You will remember that we formed last autumn a Transmitter and Relay Section, and that we gradually built up a scheme of relay work in different parts of the country. The almost inevitable result of the attempts to get relay chains working was a crop of reports that so-

and-So was washed out by somebody else breaking in on the same wavelength with some gramophone tune or something of that kind ; or that somebody had been interrupted by a person using his own call sign illegitimately. The state of affairs, as I say, seems to be getting worse rather than better. There are three parties interested in this matter. There is the amateur who wants to do his work in a reasonable manner ; there is the broadcast listener who is very often on the same waveband as these interrupters ; and then, last but not least, there are those who are using wireless for transmitting messages on Government service or for commercial purposes. Of these three or four parties who are injured by the erratic type of transmitter, the Government and commercial users have become tolerably free because they have developed means of taking care of themselves, and, moreover, they can place good apparatus in the hands of skilled operators. The broadcast listener is the next in order of martyrdom but his interests are being ably protected by the British Broadcasting Company, which, in this aspect, is a solid single-minded organisation for looking after the broadcast listener. The real martyr is, I think, the true amateur of the kind that forms the bulk of our Society. This man, when broadcasting began, bound himself of his own initiative by a self-denying ordinance to refrain from transmitting during broadcasting hours on the wavelengths that would interfere with broadcasting reception anywhere. In addition to this sacrifice of his experimental time he found also that if he lived near a broadcasting station he could do no experimental reception during the time the broadcast station was running, on account of the width of band natural to a telephonic station. His work, therefore, became postponed until after 11 o'clock at night. This left the British Broadcasting Company to deal with the inconsiderate or anti-social transmitter who sometimes disturbs the peace. But once these people were scared, they transferred their energies to the post-broadcasting hours, with the dire result that the self-disciplined amateur finds himself at 11 o'clock at night in the midst of a perfect thicket of noise, in many cities, at any rate.

Tracing Disturbers.

During the past year the British Broadcasting Company has kept in close touch with our late Honorary Secretary, Mr. McMichael, and have sent him copies of many of the complaints which they have received from disturbed broadcast listeners. Mr. McMichael started last March a scheme for mobilising local wireless societies in the work of tracking and, if possible, eliminating the disturbers ; but he found, I think, that it would require much labour and much money to carry out thoroughly any scheme of this kind, and I think that in the end his efforts gradually tapered off on account of the sheer impossibility of the task. Even in districts where it has been possible to trace and stop one howler, two or three new ones have started up for each one stopped. The reason is that the rapid expansion of broadcast listening brings in some new beginner with a valve set every day or every week, according to the district, and the beginner requires time to learn the set. Some of them learn to adjust it silently and to leave it alone within a month ; but the weaker

vessels take six months, and have then not yet concluded.

Lately I looked through a batch of recent letters of complaint of programmes spoiled and I tried to diagnose in each case the probable source of the trouble. About three quarters of the disturbers seemed to be valve learners, but they, as a source of irritation, disappear in a few weeks or months. A small fraction were chronic crystal ticklers who, if very near to sensitive neighbours, cause great mental distress. I daresay that many of you know that if your next door neighbour insists on scratching his crystal while his aerial is oscillating strongly under the broadcast waves, he radiates every scratch to you and spoils your music and language. To these people one can only quote Lord Palmerston and say "Why can't you leave it alone ?" But it seems to be too much to ask human nature to leave well alone, for even after obtaining an excellent rendition they say to themselves, "I wonder if it would be better if I turned that knob a little farther," and so it goes on.

With these classes of disturbers very little can be done by any Society like ours, or by the Government, or by the British Broadcasting Company. We in this Society have seen enough of the complaints and looked at them carefully enough to be sure that the stopping of that trouble is as great a problem as suppressing the piano-playing of a neighbour or suppressing the nocturnal cat. It is just a nuisance, and it may have to be tackled in due course under the common law as a nuisance. As a rule the common law has succeeded in adapting itself in due time to deal with all newly-invented nuisances that civilisation brings ; but to return to the analysis of complaints of broadcast listeners, I think about 10 per cent. of the disturbances are due to amateur transmitters, and under 10 per cent. due to wilful interference. You will, I think, agree with my seemingly harsh diagnosis of the last category, the wilful interferer, when I tell you that in the interferences sometimes recorded, the interpolations consist of remarks, at apparently appropriate points of the sermon, of such words as "rats." Now, of course, that cannot be accident ; it is someone with a transmitting set and a gramophone who is intentionally creating a nuisance. I say that less than 10 per cent. of the broadcast complaints seem to come into the category of wilful disturbance.

Meeting the Complaints.

Cases like this do, in a sense, concern the wireless societies, and they must be grappled with if we can trace them to our membership, but the cases where the genuine amateur transmitter is interfering with the broadcast listener is in a different category and requires special consideration. In the first place, many of the complaints of the broadcast listener arise because his apparatus is so badly designed or constructed that though it is tuned to 365 metres it is easily disturbed by a transmitter at 180 metres, say. From the scientific point of view, the remedy is simply a filter circuit in the listener's aerial ; but from the popular point of view the amateur is a person who is merely playing with wireless, and when the would-be listener to the broadcast concerts comes near to him and

installs poor apparatus, the assumption is that it is the amateur who must shut down. This, of course, is a gratuitous assumption that the broadcast listener has a stronger right to install poor apparatus than the transmitter has to transmit on a reasonably sharp wavelength. But it does not follow that because a man listens in to, is it Uncle Jeff(?), that he is therefore a better citizen than an experimental transmitter. But that kind of thing has always haunted scientific enquirers. Entertainment, for instance, is, to unthinking people, much more important than any possible good, national or social, that may flow from a scientific study or hobby. This has been the attitude of the crowd towards the discoverer and investigator throughout all history. In all such cases those who know better have had to combine and fight those who know nothing. In this particular case we are combining as a Society, but we can only meet the unreasonable complaints of the ill-equipped amusement seeker by our being sufficiently strongly organised to demand impartial enquiry and to ensure a just decision. On the other hand we can meet the justifiable complaints of the other users of wireless, and can obtain more time for ourselves and clearer times for ourselves, by getting every well-intentioned amateur to join our Society or an Affiliated Society, and after that establish a code of honour and a system of self-discipline amongst ourselves.

Admiral Sir Henry Jackson.

I have great pleasure in welcoming Dr. Eccles to the Presidential Chair again, and I am sure you will all join with me in that. He began his lecture by saying that he feared we should get bored by hearing him lecture so often, but I think he is wrong there. The more we hear him the better we like it, because he is such a great authority on the many subjects that he deals with. He has left the scientific side alone this evening, and has given us what I might call a monetary lecture. He has also put it in such a humorous way that I think we all appreciate it. Certainly I hope all those who read this lecture will take note of what he has said and see to do that which he so strongly recommends. It is a great privilege to have a lecture of this sort and to be told what the duties of such a Society as ours is, and also what are the duties of wireless users to the public in general. We have learned what our duties are to-night, and what is the duty of every individual, and I hope what the President has said will go home. Dr. Eccles certainly did no more than give the due credit to those amateurs who have carried out those marvellous transatlantic tests. I personally am one of those fishers in the ether to whom the President has referred. I do not put any spawn in, but I try to get some fish out (laughter), and I think it is a very nice analogy to compare fishers in water with fishers in the ether as Dr. Eccles has done. I am particularly interested in the reference to the use of the 100 metres wave for transatlantic communication, using the Austin-Cohen formula, and if our honorary secretary would take some steps to try and get more details of the various factors that go to make up that Austin-Cohen formula, it would be of very great value. If the Radio Research Board can help in any way we shall be only too pleased to do so because it is

of very great scientific interest, and it is this Society which has brought it forward. I ask you to join with me in giving a very hearty vote of thanks to the President for his Address.

Brig.-Gen. Sir Capel Holden.

I have very great pleasure in seconding the vote of thanks so ably proposed by Sir Henry Jackson.

The vote of thanks was carried with acclamation.

The President then announced that all the new members balloted for had been elected, and that three new wireless societies had been accepted for affiliation.

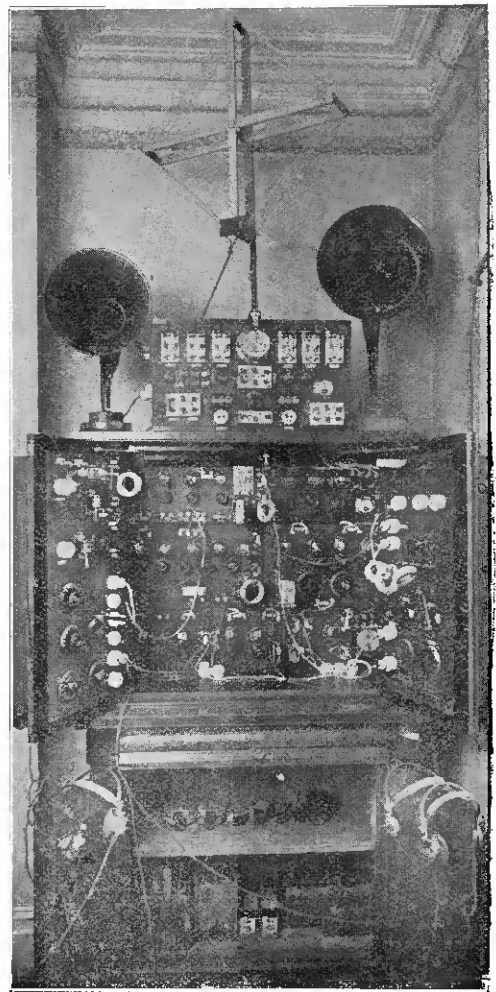

The experimental receiving equipment of Mr. R. F. Lamport, of Croydon. The set is modelled on the unit system, providing a multiplicity of different circuits.

RESISTANCE, CHOKE, OR TRANSFORMER LOW FREQUENCY COUPLINGS

By W. JAMES.

(Concluded from page 583 of previous issue.)

CHOKE COUPLING.

When a choke coil is connected in the anode circuit, as in Fig. 1B,* we have what is called a choke coupled low frequency amplifier. It will be noticed that coupling condensers are used between the anode of the first valve and the grid of the next in the same way as in a resistance-capacity coupled amplifier.

If the coil has an inductance of L henries, its reactance X ohms at the frequency f is equal to $2\pi fL$ ohms. The inductance value referred to is not the inductance of the coil which might be obtained by measurement in the usual way, but the actual inductance when the coil is connected in the circuit with the normal anode current flowing through the winding. The inductance under working conditions is very likely considerably smaller than the value of inductance when the coil is not carrying a current.

If we suppose the coil possesses negligible resistance, the amplification obtained may be written†

$$A = \frac{V_2}{V_1} = \frac{\mu X}{\sqrt{R_p^2 + X^2}}$$

where μ = the voltage amplification factor of the valve (μ is supposed to equal 10 for the purpose of these examples).

X = the reactance of the anode choke coil.

R_p = the valve anode-filament alternating current resistance (assumed to be 40,000).

Assuming that the valve has the constants given above, we may find the voltage amplification when various reactances are connected in the anode circuit as follows:—

(1) Reactance of coil = 10,000 ohms.

$$A = \frac{\mu X}{\sqrt{R_p^2 + X^2}} = \frac{10 \times 10,000}{\sqrt{40,000^2 + 10,000^2}} = 2.4.$$

(2) Reactance of coil = 30,000 ohms.

$$A = \frac{10 \times 30,000}{\sqrt{40,000^2 + 30,000^2}} = 6.$$

(3) Reactance of coil = 80,000 ohms.

$$A = \frac{10 \times 80,000}{\sqrt{40,000^2 + 80,000^2}} = 9.$$

By working out a few more examples, sufficient data will be obtained to enable one to plot a curve showing the relationship between the amplification obtained and the reactance of the coil in ohms. Such a curve has been plotted, and is given in Fig. 3.

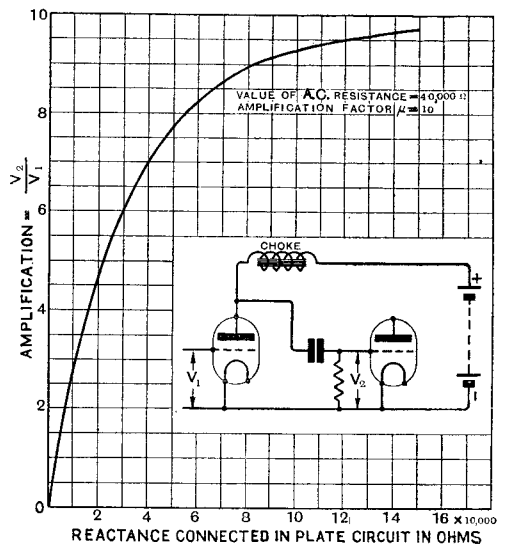

Fig 3.

It will be noticed that when the reactance in ohms is only twice the internal resistance of the valve, 90 per cent. of the total possible voltage amplification is obtained. This is an important result, because in the case of resistance amplification it is necessary to

*Page 580, *Wireless World*, Feb. 6, 1924.

†When the resistance of the choke is not negligible, $A = \frac{\mu X}{\sqrt{(R_p + r)^2 + X^2}}$ where r is the direct current resistance of the choke.

connect a resistance equal to approximately 10 times the valve resistance in the anode circuit to obtain a voltage amplification of 90 per cent.

Actual choke coils, of course, have resistance as well as inductance, but the resistance is generally quite small compared with that of the valve, so that the amplification is only slightly different from that obtained by assuming there is no resistance.

To ensure that the dynamic or working characteristic of the valve is straight over the region occupied when amplifying, it is advisable to use a choke whose reactance is at least twice the internal resistance of the valve. Therefore a choke whose inductance under working conditions is equal to $\frac{80,000}{2\pi f}$ henries will be satisfactory (reactance = $2\pi fL$). If the lowest frequency to be amplified is 200 cycles, the inductance is

$$\frac{80,000}{2 \times 3.14 \times 200} = \text{nearly } 65 \text{ henries.}$$

With a coil having this inductance in the anode circuit, the amplification obtained when the frequency is 200 is 9.

It will be noticed that there is likely to be distortion through one element of the signal being amplified more than another if the choke has not a sufficiently large inductance. For example, suppose the choke has an inductance of only 12.8 henries. At a frequency of 500 cycles the reactance is 40,000 ohms, and from the curve of Fig. 3, the amplification is 7; for an element of the signal having a frequency of 250 cycles, the reactance is 20,000 ohms, and the amplification only 4.5; for a frequency of 1,000 cycles the reactance is 80,000 ohms and the amplification is 9. The 250 cycle element of the signal is only amplified to the extent of one-half of the 1,000 cycle signal.

By making the inductance large, say 65 henries as above, the amplification of the various frequencies is only very slightly different—not sufficient to cause appreciable distortion.

The following points should be noticed :

(1) By employing a choke coil whose working inductance is so large that its reactance at the lower speech frequencies is at least twice the anode-filament resistance of the valve, the amplification obtained of all the speech frequencies is, for practical purposes, uniform.

(2) When the reactance is only twice the anode-filament resistance, 90 per cent. of the possible voltage amplification is obtained. The full amplification could only be obtained by making the reactance infinitely great; but from the curve, Fig. 3, it is seen that there is no practical gain in amplification by the use of a choke with a reactance larger than about twice the valve resistance.

(3) The anode voltage does not need to be increased beyond that determined from the characteristic curves of the valve, because chokes have, in general, quite a negligible direct current resistance.

(4) The remarks concerning the coupling condenser and grid leak made under the heading of resistance capacity coupling apply in the case of choke coupling.

TRANSFORMER COUPLING.

Note magnifiers are usually coupled by means of a transformer, as in Fig. 1C, where *P* represents the primary winding and *S* the secondary winding. The turn ratio of transformers on the market varies from 2-1 to 5-1. The turn ratio unfortunately is no real guide to the voltage amplification which may be obtained. It might be thought that it is only necessary to properly design the primary winding, and then wind as many turns as possible for the secondary winding. This is not the case.

It has been shown by a number of tests that the amplification obtained, using an ordinary receiving valve with characteristics as above ($\mu = 10$, $R = 40,000$ ohms) is of the order of 25.

No formula for calculating the amplification of one stage of transformer coupled note magnification is given here, because it is found the practical operation of a transformer is very different from that predicted theoretically, on account of a number of quantities, the magnitude of which it is not possible to predict.

CONCLUSIONS.

It is possible in practice to obtain the voltage amplification predicted by theory only in the case of resistance couplings. The amplification obtained with choke and transformer couplings is different for the following reasons.

To secure reasonable amplification it is necessary to employ coils of many turns wound upon an iron core. To keep the

transformer or choke reasonably small, fine wire is used. The result of using many turns of fine wire is that the windings possess capacity. Self-capacity and its effects may be minimised by increasing the distance between wires and layers, by reducing the induced voltages between layers, or by reducing the length of the winding.

Transformers and chokes are therefore often constructed with the turns spaced by running on cotton along with the wire. In another construction, the self-capacity is reduced by making the winding width small compared with the winding depth.

Now the effect of self-capacity in the case of a choke coil is to produce a winding which has a natural frequency, and as would be expected, the amplification obtained will be different for those frequencies in the signal which correspond with or are near the natural frequency of the coil. Further, the higher frequencies will be partly carried by the condenser so formed, so that the effective resistance of the choke to the higher frequencies will be lower than it would be if the self-capacity did not exist. However, the variation between the theoretical and actual amplification in the case of choke coils is not very great.

So far as the iron core is concerned, there are losses through hysteresis and eddy currents. The iron losses may be made negligible by careful design and the use of low-loss iron or steel. Anode choke coils are usually made with a large number of turns and an open core—*i.e.*, the core is generally not composed wholly of iron, but consists partly of iron and an air gap.

The effect of the capacity of the windings of intervalve transformers is generally not negligible, even though the greatest care is taken with the design. Many transformers amplify some frequencies better than others, due partly to the resonance effects, and to the voltage transformation ratio varying with the frequency. However, from curves which have been published it would seem that there are a few transformers which amplify all the frequencies contained in speech and music about equally well.

SUMMING UP :

(1) *A resistance-capacity coupled amplifier* may be designed to amplify all frequencies (up to many thousands of cycles per second)

equally well. A large anode voltage is needed to compensate for the fall in volts across the anode resistance. The amplification obtained is limited to that of the valve, and practically, about 70 per cent. of the possible amplification is easily obtained.

(2) *A choke coupled amplifier* may be designed to amplify the frequencies necessary for speech and music about equally well. The anode voltage required is only that normal to the valve, because the normal drop in volts across the choke is negligible. The amplification obtained is limited to that of the valve, and practically, about 90 per cent. of the possible amplification is easily obtained.

(3) *When a properly designed transformer coupling* is used, the frequencies necessary for speech and music are amplified fairly equally, and there are several transformers available which may be said, for practical purposes, to have a flat frequency characteristic. The anode voltage required is the same as that required in the case of a choke coupling. The amplification obtainable lies between twice and three times the voltage amplification factor of the valve.

It will probably be agreed that provided good transformers are employed, transformer coupling offers considerable advantages. In some cases (for instance, a speech amplifier used between a microphone and the control valves of a transmitter, where it is essential to have the very best quality amplification) the advantages of resistance amplification may outweigh the disadvantages.

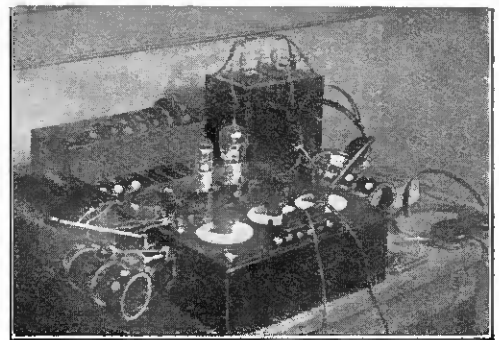

Our photo shows the receiving apparatus of Mr. J. Steffensen, of Denmark, who has been very successful in the reception of many British amateur transmissions.

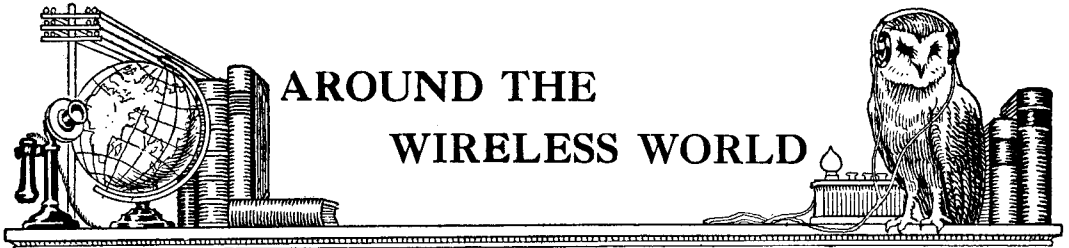

It has been agreed by the London County Council to dispense, in the case of cottages, with the £1 deposit tenants were required to pay on installing wireless apparatus.

The Associated Scientific and Technical Society of South Africa has decided to open a permanent broadcasting station, which will probably be operating in a month's time.

A company has been incorporated in Cincinnati, Ohio, with the object of giving the world a religious message daily by radio.

China, it is reported, is in the throes of a wireless boom.

A Real Radio Receiver.

To those who seek a really practical description of a wireless receiver we commend the following illuminating extract, taken from "More Letters of a Japanese Schoolboy," by Wallace Irwin (Putnam, 7s. 6d.) :—

"On Table befront of him sat one black suit case all covered with nickel plated science. It cantained a window with electric blubs doing so inside. It cantained silver pushers, pullers, arrows and Kodak supplies. It cantained so many Wires that that I was sure it was connected with Edison somewhere. It had a Horn with its mouth wide open as if to speak. It had one of those Switchboards which enable Hon Telephone Operatress to get your number wrong 13 times out of 11. Taken altogether this was a Radio."

A Transmitting Record ?

How many amateur transmitters have as yet worked with 100 other stations ? This question is asked by Mr. T. W. Higgs (5 KO), of Bristol, who is busily endeavouring to reach his century. His present "score" of 86 is made up of 54 British, 17 French, 10 Dutch, 2 Danes, 2 Canadians and 1 American.

The last three were obtained during January. On the 22nd of the month he effected two-way working with 2 BG, of Montreal, and 2 AGB, of Summit, New Jersey, while 1 BQ, of Halifax, was worked on January 26th.

Danish 7 EC.

Our note on 2 WJ's success in working with 7 EC on Saturday, January 12th, quickly evoked a report from Mr. Gerald R. Garrett (5 CS),

claiming priority, in that he established two-way communication with the Danish amateur on January 11th. This was followed, however, by news that 2 OG (Mr. A. Cooper, of York) and 5 KO (Mr. Higgs, of Bristol) had each worked with 7 EC on January 10th. 7 EC employs a single valve receiver while the anode of his transmitting valve is fed with A.C. at 800 volts, giving an aerial current of 1 ampere.

Indian Link in the Imperial Wireless Scheme.

The Indian Government announces that applications will be received till August 1st from private enterprises in India to operate the radio services providing the Indian link in the Imperial Wireless scheme. At least 60 per cent. of the capital must be offered in India.

Illicit Use of a Call Sign.

It has come to the notice of members of the Marconi (Chelmsford) Wireless Society that their call sign (5 IW) is being used by another transmitter, unknown to them. They hope that the publication of the fact will cause this objectionable practice to cease.

Brussels Aerodrome Transmissions.

Although the ordinary broadcast programmes from the Brussels Aerodrome have now been suspended, the station will transmit daily weather reports by telephony at 1 p.m., and on certain occasions at 4.50 p.m.

Transatlantic Success.

Mr. Leonard M. Baker (2 FN) of Ruddington, Notts, reports that his signals have been heard by 1 BVL, of Dorchester, Massachusetts, U.S.A., using a single detector valve. 2 FN's power was under 100 watts, developed by a small Newton generator.

New German Broadcasting Station.

Transmissions are now taking place from a new broadcasting station in Berlin, with the name of Vox Haus. A musical programme is broadcast between 8 and 9 o'clock each evening on a wavelength of 400 metres.

2 LO Heard in the Rand

Mr. G. Bekker, a wireless amateur at Port Elizabeth, has successfully received a concert from the London station, according to the *Rand Daily Mail*. A Burndept Ultra-Four Receiver was used, with an additional high frequency panel.

Irish Broadcasting.

The holders of hitherto illicit wireless sets in the Irish Free State are rejoicing at the announcement made by the Postmaster-General on February 3rd that licences are about to be issued pending the further discussion of the whole problem of broadcasting in Dail Eireann.

By this happy stroke of genius the authorities have saved themselves a good deal of unpleasantness and trouble, and they will now be free to probe the broadcasting question in a spirit of dignity and leisure. If Dail Eireann will now permit the establishment of a broadcasting station in Dublin, it is probable that listeners-in will gladly allow the authorities to carry on their consideration of the broadcasting question *ad infinitum*.

An Interim Report.

The committee appointed by Dail Eireann to consider broadcasting in the Irish Free State issued an interim report on January 31st. In the main the report advocates that broadcasting should be

Year's Eve, is to become a permanent feature in the B.B.C. programmes. The probable times of this transmission are 7 p.m. and at the conclusion of the evening programme on weekdays, and 3 p.m. and 8 p.m. on Sundays.

An Amateur in Luxembourg.

Signals from a Luxembourg station with the call sign 1JW were intercepted on January 27th, by Mr. J. W. Hefferman, of Liverpool. Reports are welcomed from other readers who have heard this station.

The Faraday Medal.

The Council of the Institution of Electrical Engineers have made the third award of the Faraday Medal to Dr. S. Z. de Ferranti, a past President of the Institution.

Dr. Ferranti was a pioneer in the supply of electricity and his early grasp of the fundamental principles of electric power supply have had a profound influence not only in this country but all over the world.

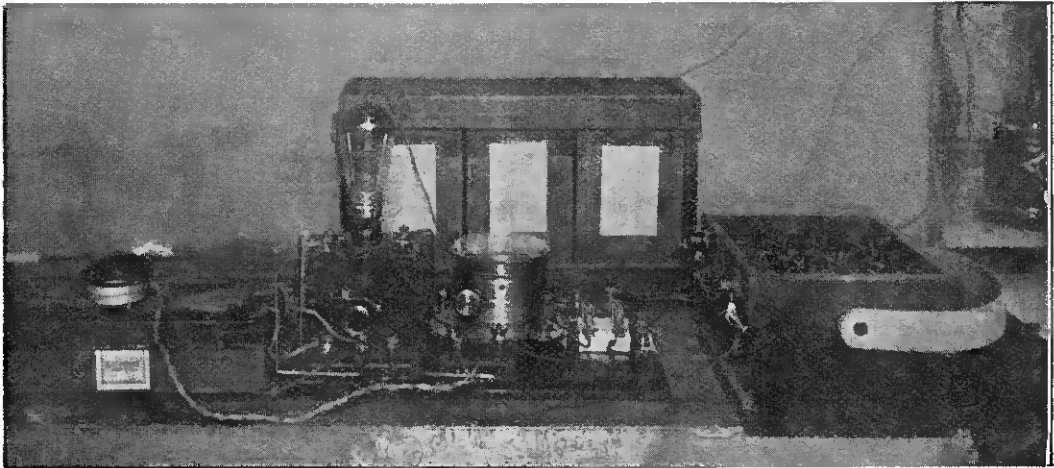

[Barretts.

The apparatus recently installed at 2 LO for the transmission of time signals. It is actuated by line wire connection with the Observatory at Greenwich.

kept rigorously under national control, and that private interests should not be allowed a monopoly of transmission.

An Anomaly.

In the light of regulations forbidding the exploitation of broadcast programmes for private gain, it is interesting that the following paragraph should appear in the current issue of the official organ of the British Broadcasting Company:—

“A PENNYWORTH OF WIRELESS.—Do you know that you can have five minutes of a broadcasting programme for the small sum of one penny? In an old-fashioned inn, near Westminster Abbey, there is installed a wireless set, and visitors, on payment of the small sum mentioned, are allowed to hear whatever the B.B.C. may happen to be transmitting at the moment.”

Broadcasting Big Ben.

The broadcasting of the chimes of Big Ben, which was so successfully carried out on New

Radio Society of Great Britain.

Radio Society of Great Britain.

An Ordinary General Meeting of the Society will be held at 6 p.m. (tea 5.30), on Wednesday, February 27th, at the Institution of Electrical Engineers. “A Practical Demonstration of some applications of the Cathode Ray Oscillograph” will be given by Mr. N. V. Kipping. Among the applications to be demonstrated are the following:—
 (1) Charting of thermionic valve characteristics; (2) Study of percentage modulation in a transmitting circuit; (3) Examination of wave-forms; (4) Accurate frequency calibration (two methods); (5) Hysteresis curves.

Conference of Affiliated Societies.

The postponed Conference of Affiliated Radio Societies is to be held on Saturday, March 1st, at 2 p.m., at the Institution of Electrical Engineers, Savoy Place, Victoria Embankment, W.C.2.

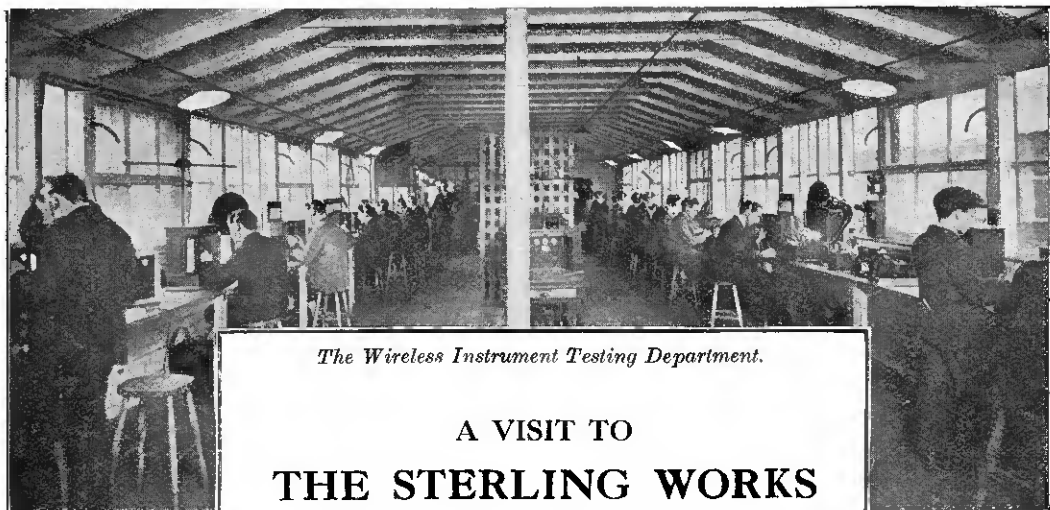

The Wireless Instrument Testing Department.

A VISIT TO THE STERLING WORKS

A VISIT was paid to the works of the Sterling Telephone & Electric Co., at Dagenham, on Wednesday, January 30th, by invitation of Mr. Guy Burney, managing director. The invitation was extended to representatives of the technical electrical and wireless press.

On arrival at the works the party was introduced to Mr. Max Lawrence, works manager, and were entertained to luncheon.

A visit of inspection was then made to the principal sections of the works, though in view of the fact that the works cover a total area of some 12 acres, and that many of the sections visited were of so much interest, far more time was spent than had been anticipated in the programme, and it was by no means easy to make a complete tour of the works in the time available.

It will be remembered that the manufacture of wireless apparatus only forms a part of the activities of this company, their principal business being the production of telephone apparatus of all kinds, largely for the requirements of the General Post Office.

Their interest in the production of wireless apparatus is really only of recent date, but the experience which they have of the manufacture of telephone apparatus has been of the utmost use in assisting in the development of the wireless side of their business.

The Sterling receivers for broadcast reception are so well known that they need not be referred to in detail here, but special mention may be made of the Threeflex

receiver, which is a comparatively new product, and is a three-valve receiver employing dual amplification.

It is interesting to note in passing that where the sets are finally tested, 25 aerials are employed, with special precautions in order to avoid mutual interference. The neatness of wiring and general finish of the apparatus is particularly noticeable, and can no doubt be attributed largely to the long experience of this company in the manufacture of telephone apparatus.

The process of winding coils for head telephones attracted considerable interest, and other processes in the manufacture of telephones, such as stamping out the magnets and the treatment which the various components undergo before they are finally assembled as complete telephones.

The wood-working shops were a veritable hive of industry, and the machinery employed was of the most up-to-date nature, enabling mass production of high-class cabinet work. All wood work is polished by means of spraying, and practically no hand polishing is undertaken.

Another department which attracted considerable interest was the shop where loud speakers were being produced, in particular the skill of the operator engaged in spinning the metal flares of loud speakers.

Naturally in a brief reference to this visit it is not possible to do anything like justice to the various sections, even if attention is confined to the wireless departments alone.



Loud-speaker horns passing through the polishing shop.



Assembling loud-speakers from finished components.

PATENT ABSTRACTS.

Improvements in Thermionic Generators.

There are several methods of obtaining a negative voltage for the grid circuit of a valve. One method is to connect the grid return wire to a suitable negative point of a grid battery. Another method* consists in connecting a resistance between the negative terminal of the filament battery and the negative terminal of the anode battery or generator. The anode current flowing through the resistance sets up a potential difference equal to $R \times I$ across the ends of the resistance, and if the grid return wire is connected with the negative terminal of the anode battery, the normal grid potential will be $R \times I$ volts negative with respect to the end of the filament to which one side of the resistance is joined.

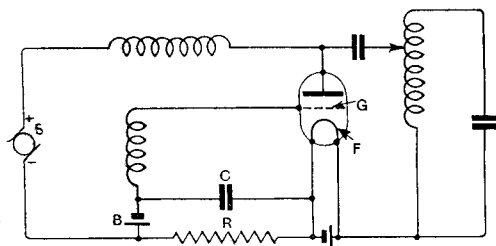

Fig. 1.

Referring to Fig. 1, the resistance R is connected between the negative terminal of the anode generator S and the filament battery. The grid G is connected through the usual grid circuit coil to the negative terminal of the grid battery B, to the end of the resistance. The normal grid potential is therefore equal to that due to the battery, plus the fall in voltage across the resistance. A condenser C is joined across the resistance and battery to provide a low impedance path for varying currents. Oscillations may be generated in the usual way by providing coupling between the grid and anode coils. If the resistance R is varied, the negative potential of the grid is varied accordingly, producing corresponding changes in the

*British Patent 193,387, by Gesellschaft für Drahtlose Telegraphie.

output power. The resistance may be varied by suitably connecting a key for Morse transmission, or by speech.

Receiving Circuits.

It is the general practice to carefully tune the circuit between the grid and filament of the first valve and the aerial and earth by including in it tuning coils and condensers or a variometer. If the values are so chosen that the circuit may be tuned to the same frequency as the incoming signals, and the apparatus is well designed so that its losses are low, the tuning is generally selective, and full advantage taken of the signal voltages set up in the aerial.

It is claimed,* however, that much better selectivity and freedom from atmospheric interferences is obtained by connecting the aerial directly to the grid of the valve, and the earth to the filament, Fig. 2. Further, it is said that with this arrangement it is not possible to energise the aerial as the result of tight coupling between the reaction and anode coils.

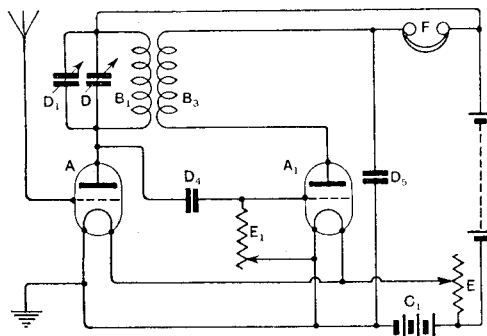

Fig. 2.

Referring to the figure, the anode of the valve A is connected to the tuned anode circuit, consisting of coil B_1 , tuning condenser D and vernier D_1 . The condenser D_4 is connected to the grid of the second valve with the variable grid leak E_1 . The reaction coil B_3 is coupled to the anode coil. The telephones are marked F, the by-pass condenser D_5 , the filament resistance E, and filament battery C_1 .

W.J.

*British Patent 267,720, by W. Diggle.



Particulars of Membership of any Society can be obtained on application to the Secretary. Societies marked with an asterisk are affiliated to the Radio Society of Great Britain.

Huddersfield Radio Society.*

A joint lecture and demonstration was given on Tuesday, January 22nd, by Messrs. J. T. Thornton (lecturer) and J. L. Goss (demonstrator). The subject, "Receiving circuits and interference," was specially chosen owing to the large amount of interference that is being caused by inexperienced persons operating sets. Mr. Thornton gave a general description of the principles of receiving circuits, followed by an explanation of the causes of interference. Messrs. Thornton and Goss then demonstrated, by means of the society's four-valve receiver and a single-valve set, how even a small wireless receiver could cause considerable interference. Broadcast music, etc., was tuned in from the Manchester station on the outdoor aerial in the usual manner, and made audible by means of the loud speaker. The single-valve set was connected to a small indoor aerial, and was caused to oscillate, with the result that a series of loud howls and whistling noises was heard from the loud speaker, thus reproducing on a limited scale the conditions which exist when interference is being caused by the improper use of a wireless receiver.

Hon. Sec., J. A. Badham, 14, John William Street, Huddersfield.

The Lewisham and Catford Radio Society.*

Thursday, January 24th, was the Society's "Short Talks Evening," the first to be held this year, and was voted an enormous success. The evening was solely devoted to short lectures by members on any subject concerning wireless and a time limit was fixed of 15 minutes for each speaker. Amongst the many lecturers were the following:—Mr. A. T. Marsh, "Switching Advantages and Disadvantages." Mr. F. A. L. Roberts, "Variometers and other Tuners." Mr. Carpenter, "Resistance and Voltage Drop," and Mr. L. M. Hewitt, "Low Frequency Resistance Coupled Amplifiers." It is to be hoped that many other members will be anxious on the next occasion to let all and sundry hear from them on their special subjects.

Hon. Sec., F. A. L. Roberts, 43, Adelaide Road, Brockley, S.E.4.

Hinckley Radio Society.*

A successful meeting was held on January 23rd, when short addresses were given by Mr. Vigers on "Home Made Coils," Mr. Percy Roberts on "A Portable One-valve Set and a New Type of Indoor Aerial," and Mr. D. E. Price, B.Sc., on "Television."

Hon. Sec., D. E. Price, B.Sc., Butt Lane, Hinckley.

Sydenham and Forest Hill Radio Society.*

The Secretary of the Society has received several complaints of experimenters oscillating and causing inconvenience to their neighbours in the Crystal Palace district. 5 DT, the

Vice-President of the Society, is now giving this matter his attention with his direction finding apparatus and several offenders have been located and cautioned. Broadcast listeners have become so used to "finding the station" by the "squeak" method that they do not think they can receive the station unless they first hear the squeal of the carrier by making their sets oscillate.

Join the Sydenham and Forest Hill Radio Society and learn how to tune by the "Squealless Method" and note the difference.

Hon. Sec., M. E. Hampshire, 139, Sydenham Road, S.E.26.

Streatham Radio Society.*

On January 9th an interesting lecture was given by Mr. Ward (2 Q8) upon the use of alternating current in transmitting.

An instructive lecture was given by Mr. H. J. Swift upon "Super-Regenerative Circuits," on January 23rd. The lecturer described the Armstrong and Flewelling circuits in detail, and gave much valuable and practical information regarding the workings of these systems, following with a demonstration on a portable set which gave excellent results.

The Society is holding its second annual dinner on February 14th, at the Telegraph Hotel, Brixton Hill, at 8 p.m.

Hon. Sec., H. Bevan Swift, 49, Kingsmead Road, Tulse Hill, S.W.

The Radio Society of Highgate.*

The 98th meeting of the Society was held on Friday, January 18th, when Messrs. Matthews and Hare gave a lecture and demonstration, their subject being "Unit Systems." The wiring of the units, as manufactured by Messrs. Peto-Scott, Ltd., was carefully explained by means of blackboard diagrams, and several very ingenious arrangements were shown whereby the circuits could be rapidly and simply changed for experimental purposes. The transmission from 2LO was received at very good strength on a frame aerial, using 3 valves.

On Friday, February 1st, an interesting lecture was given by Mr. F. L. Hogg, who is well known amongst amateurs as 2 SH. Mr. Hogg dealt with aperiodic loose-couplers, which give the advantages of ordinary loose-couplers with the further benefit of simplicity in tuning, since one of the tuning condensers is eliminated. Constructional details were given, and some useful hints were offered on the manipulation of such an arrangement. Mr. Hogg also described a circuit for reception on wavelengths below the fundamental wavelength of the aerial. This circuit should prove very useful to those who possess fairly long aerials.

A programme of forthcoming attractions, and full details of membership, etc., may be obtained from the Hon. Sec., J. F. Stanley, B.Sc., 49, Cholmeley Park, Highgate, N.6.

Smethwick Wireless Society.*

A successful meeting was held on February 1st, when Mr. A. W. Parkes gave a demonstration of his receiver, using D.E. valves.

Among interesting lectures recently given was one on the printing of radio signals, by Mr. Woodcock (2 ZD), who accompanied his remarks with a demonstration.

Intending members are requested to apply for particulars to the Hon. Sec., Ralph H. Parker, F.C.S., Radio House, Wilson Road, Smethwick, Staffs.

Iford and District Radio Society.*

On January 24th, Mr. Wood, a new member of the Society, lectured upon and demonstrated a receiver using double magnification.

Local broadcasting was received and considering that the aerial and earth system was not of the best, the results were extremely good. Good loud speaker strength was obtained using as an aerial a piece of wire about 15 ft. long.

Hon. Sec., L. Vizard, 12, Seymour Gardens, Iford.

The Southampton and District Radio Society.*

On Thursday, January 24th, before a large assembly of members, Mr. Bateman lectured on a new dual amplification circuit which he has devised. Two valves are used, giving two stages of high frequency and two stages of low frequency amplification, with crystal rectification. Excellent results are obtainable, speech being clearly audible 200 yards from the loud-speaker. The lecturer gave the members the benefit of his experiments, and described the circuit step by step in such a manner as to be clearly understood by even the newest recruit to wireless. He afterwards gave a demonstration with the set, broadcasting being splendidly received, with a notable freedom from distortion.

Hon. Sec., P. Sawyer, 55, Waterloo Road, Southampton.

Chesterfield and District Radio Society.*

At the weekly meeting of the Society, held on January 29th, the chief feature of the evening was a demonstration given by Mr. W. Coombs with a one-valve Reinartz circuit. Various items were distinctly heard from three of the B.B.C. stations, and taking into consideration the meagre range of an ordinary one-valve set, the results obtained were considered very extraordinary. The society are very keenly interested in these experiments, and a series of evenings have been arranged wherein tests are to be made with various circuits. The Society will be pleased to welcome all wireless enthusiasts to join in this interesting research work. Hon. Sec., A. F. N. Wood, 15, Spital Lane, Ches'

Newcastle-on-Tyne Radio Society.*

On Monday, January 21st, a very interesting demonstration was given of a single-valve set using only a frame aerial, and Newcastle broadcasting was heard all over the lecture room with the telephones on the table. The set was kindly lent by Messrs. Walkers Wireless. On Monday, Jan. 28th, Morse classes were restarted and will be continued every Monday at 7 p.m. An interesting series of lectures has been arranged for the rest of the season.

Hon. Sec., Colin Bain, 51, Grainger Street, Newcastle-on-Tyne.

Liverpool Wireless Society.

A meeting of the Society was held on January 10th, at the Royal Institution, Colquitt Street, the Society's President, Prof. Marchant, occupying the chair.

The first event of the evening was an address, with limelight illustrations, by Prof. Marchant, on the effect on reception of interfering signals and atmospheric disturbances. Various attempts at balanced valves and trap circuits were shown diagrammatically, and the underlying principles and theories of their construction and operation explained.

One method, involving a resistance in the aerial circuit, came in for special mention, but whilst this method was very successful in getting rid of some disturbances, a considerable reduction of signal strength resulted.

A demonstration of the Hinton circuit, which was favoured by Prof. Marchant, was given by Mr. Latimer, of the Liverpool University Staff, and the broadcast programme was well received with little interference from Seaford and shipping.

Mr. G. S. Rowe, of the Mobile Radio Co., of America, who visited the Society, was given a hearty welcome by the Society's Chairman, and explained that in America he had experimented extensively with inductance coils and condensers of varying values in the aerial circuit, and had found that one inch of square copper, bent to form an 18 in. coil, and a small capacity condenser put in the rejector circuit, was of great value as an eliminator.

Hon. Sec., Geo. H. Miller, 138, Belmont Road, Liverpool.

The Honor Oak Park Radio Society.

On January 11th Mr. A. Romaine Carpenter, A.M.I.E.E., gave an extremely interesting lecture on "Reminiscences of War Wireless." He gave his experiences at a British Direction Finding Station, and described the methods of locating enemy airships, submarines, and battleships by means of their wireless calls. The lecturer also gave an amusing account of his duties as wireless officer in the "Feed the Guns" campaign.

After the lecture Mr. Blandey demonstrated a one-valve dual set, using tuned anode H.F. coupling, which worked the loud speaker extremely well.

The meeting closed with a vote of thanks to Mr. H. W. Saxton, the retiring chairman, for his valuable services to the Club.

On January 18th, Mr. F. Gandon gave an interesting talk on a double-magnification set, which he had built up on a board to show all connections, and component parts. He explained the use and functions of the stabilising resistance which supplies a positive potential to the grid of the dual valve. Owing to a breakdown in one of the L.F. transformers the set did not give the expected volume, but the tone was exceptionally good owing partly to the crystal detection.

The meeting closed with a general discussion on reflex circuits.

Hon. Sec., J. McVey, 10, Hengrave Road, Forest Hill, S.E.

St. Pancras Radio Society.

The Society met at the headquarters, 1, Mornington Crescent, N.W.1, on Thursday, January 17th, when Mr. R. T. Nunn gave a demonstration and lecture on "The Recording of Morse Signals." The speaker first traced the evolution and history of recording methods, explaining the system of the coherer and the experiments carried out by Turner, Creed and others, and illustrating his remarks by careful blackboard diagrams and very lucid analogies.

He subsequently illustrated his lecture by means of a two-valve receiver, amplifier, Brown microphone amplifier, Post Office relay, and Morse recorder, signals being received from Ongar, North Weald and Eiffel Tower.

Hon. Sec., R. M. Atkins, 7, Eton Villas, Haverstock Hill, N.W.3.

Hendon Radio Society.

A practical and informative lecture on "Reflex Circuits" was given on January 17th by Mr. W. E. Milton Ayres, A.M.I.E.E., Mem. A.I.E.E. After explaining the principles of a normal valve-crystal circuit, the lecturer dealt with a number of original modifications he had introduced to increase its efficiency and selectivity, including the use of the L.F. transformer as an auto-transformer, and of a double slide tuner for controlling reaction. A demonstration with a two-valve set (one valve reflex and detector) was given on a short indoor aerial, and excellent loud speaker strength with great purity of tone was obtained. The stability of this set depended largely on the complete separation of the high and low frequency oscillations by means of condensers and choke coils, and in this connection Mr. Ayres incidentally expressed the opinion that the authors of a number of valve detector reflex circuits, in which this separation was not effected, were unduly optimistic as to their stability with even the most skilful handling.

Hon. Sec., E. A. Lynn, 79, Sunny Gardens, Hendon, N.W.4.

Glasgow and District Radio Society.

On January 16th, a lecture was given by Mr. J. Henderson, M.C., B.Sc., entitled "Energy Supply for Filament and Plate in Valve Reception."

The lecturer explained and gave a very clear practical demonstration of various methods of eliminating the ripple from both direct and alternating current house mains. A loud speaker enabled members to judge the several methods for themselves. So clear were the results that it would have been impossible for anyone to tell that the set was not operating off an ordinary battery.

Hon. Assst. Sec., Wm. K. Fulton, 148, Kennure Street, Pollokshields, Glasgow.

Radio Society of the University of Birmingham.

On January 19th a very enjoyable afternoon was spent in visiting the Birmingham Broadcasting Station, both the studio and the transmitter being inspected, through the courtesy of Mr. Edgar, the station director.

Hon. Sec., M. Heywood Hunt, University Club, Edgbaston, Birmingham.

North Middlesex Wireless Club.

On January 23rd, a lecture on "Valves and their Characteristics" was delivered by Mr. W. J. Jones, B.Sc., A.M.I.E.E., of the Cossor Valve Company.

In his preliminary remarks the lecturer called attention to the debt which modern wireless practice owes to the organised experiments of groups of amateurs, both in this country and in America. He detailed some of the most

important stages in the evolution of the thermionic valve, from Edison's discovery to the production of the coated filaments from which electrons are evolved at a much lower temperature than in the case of the ordinary type of valve.

After describing the various processes in the manufacture of the valves, Mr. Jones exhibited some characteristic curves of the ordinary detector valve, and also of the special type designed for high frequency work.

Hon. Sec., H. A. Green, 100, Pellatt Grove, Wood Green, N.22.

Radio Association of Ireland.

On Thursday, January 31st, Mr. T. J. Monaghan, B.Sc., A.M.I.E.E., gave a very interesting lecture on "The Valve viewed as a Converter," and thoroughly explained his subject by means of diagrams.

In the opinion of those present the lecture was one of the very best that has yet been given under the auspices of the Association, and a hope was expressed to hear Mr. Monaghan lecture again in the near future.

Hon. Sec., J. P. Murphy, 45, Henry Street, Dublin.

Barking and District Radio Society.

The Society has changed its headquarters from The Congregational School Room to the Railway Hotel, Longbridge Road, Barking. The future weekly meetings of the Society will be held on Saturday instead of Tuesday as heretofore, commencing at 8.15 p.m.

On Tuesday, January 22nd, an interesting lecture was delivered by Mr. A. T. Thompson (5 KT), on methods of amplification. After dealing with the four types of high frequency in a very lucid manner, the lecturer discussed several points dealing with low frequency and its uses. The lecture was well illustrated with blackboard diagrams.

Hon. Sec., C. R. Willett.

The Clapham Park Wireless and Scientific Society.

Mr. G. H. Hurst, representing the Western Electric Co., gave a successful demonstration of the firm's power amplifier and loud-speaker on Wednesday, January 9th. He explained the principal features of these, and also showed several other sets utilising "Wecovalves" including a frame-aerial set.

On January 16th, Mr. Brierley brought a four-valve set for members to try out, and the following week being the monthly "Testing Night" various components were exhibited, including a loud-speaker set by Mr. Griffiths.

Mr. G. W. Walton, of the General Radio Co., lectured on "Television," on January 30th. The subject being a novel one, it aroused great interest, and a keen discussion followed.

Intending members are invited to attend meetings on Wednesdays, at 67, Balham High Road, at 7.30 p.m., or to communicate with the Secretary, Mr. H. C. Exell, B.Sc., A.I.C., 41, Cautley Avenue, S.W.4.

Derby Wireless Club.

The 13th annual general meeting of the Society was held on January 10th. After the report and balance sheet for 1923 had been approved, the following officers were elected for the present year:—President, Mr. F. W. Sherlock, B.A., B.Sc.; Vice-Presidents, Messrs. S. G. Taylor, T. P. Wilmshurst, A. T. Lee and J. J. Spencer; Chairman, Mr. E. V. R. Martin; the Hon. Secretary and Treasurer is Mr. E. W. Kirk.

An auction sale for members only will be held on Thursday, February 21st, at 29, Curzon Street (through the kindness of Mr. Tawn).

Hon. Sec., E. W. Kirk.

Calls Heard.

Broadcasting.

Port Seton, N.B.

2 AQ, 2 CW, 2 DF, 2 DR, 2 FN, 2 HD, 2 JF, 2 KF, 2 KR, 2 LZ, 2 MC, 2 MM, 2 MO, 2 NM, 2 OD, 2 OM, 2 OX, 2 OZ, 2 QN, 2 VO, 2 YQ, 2 WS, 2 WK, 5 DN, 5 DT, 5 GJ, 5 HL, 5 KO, 5 MO, 5 QV, 5 SL, 6 DW, 6 NL, 6 RQ, 6 UC, 8 AQ, 8 AS, 8 BY, 8 CH, 8 CJ, 8 CS, 8 DX, 8 DV, 8 ONY, 8 PZ, 8 RZ, 8 XA, 8 XO, 8 XP, 8 YS.

(E. A. Anson, Capt.)

West Norwood, S.E.27.

2 DX, 2 FL, 2 MG, 2 MM, 2 TF, 5 OT, 5 PJ, 5 QV, 5 SL, 8 AE, 8 AEL, 8 AEE, 8 ARA, 8 BE, 8 BL, 8 CH, 8 CT, 8 EB, 8 LS, 8 KX, 8 NB, 8 RM, 8 XO, 8 XW, 1 MT, 1 JW. (Single valve).

(L. F. Aldous.)

Sidcup, Kent.

2 AO, 2 BF, 2 BO, 2 BP, 2 BZ, 2 CH, 2 CI, 2 CO, 2 CX, 2 DT, 2 DU, 2 FG, 2 FK, 2 FQ, 2 FZ, 2 IB, 2 IL, 2 IO, 2 IP, 2 KC, 2 KD, 2 KF, 2 KG, 2 KH, 2 KI, 2 KJ, 2 KV, 2 KW, 2 KZ, 2 LI, 2 LT, 2 LV, 2 LW, 2 LZ, 2 MF, 2 MK, 2 MN, 2 MT, 2 NI, 2 NM, 2 OK, 2 OL, 2 OM, 2 ON, 2 PD, 2 PL, 2 PP, 2 PQ, 2 PW, 2 PX, 2 PY, 2 PZ, 2 QI, 2 QK, 2 QQ, 2 QT, 2 QU, 2 QV, 2 RM, 2 SF, 2 SH, 2 SK, 2 SL, 2 SQ, 2 TA, 2 TL, 2 TG, 2 VH, 2 VK, 2 VW, 2 WS, 2 WT, 2 XZ, 2 ZO, 5 AN, 5 AU, 5 AW, 5 BK, 5 BT, 5 BV, 5 CB, 5 CH, 5 CK, 5 CP, 5 CS, 5 CW, 5 DB, 5 DK, 5 DT, 5 DY, 5 FL, 5 FR, 5 FS, 5 HI, 5 HK, 5 HY, 5 HZ, 5 IF, 5 IH, 5 IO, 5 IP, 5 JW, 5 KW, 5 LZ, 5 MS, 5 NO, 5 OB, 5 OH, 5 OL, 5 OO, 5 OM, 5 OY, 5 PC, 5 PD, 5 PT, 5 PU, 5 PV, 5 PY, 5 PZ, 5 QV, 5 RM, 5 SU, 5 TB, 5 TC, 5 TZ, 5 UG, 5 UO, 5 VA, 5 VF, 5 VP, 5 VR, 5 VU, 5 VW, 5 WF, 5 WR, 5 WS, 5 XC, 5 XR, 5 XY, 6 DU, 6 DW, 6 GW, 6 HX, 6 IM, 6 JS, 6 LJ, 6 MG, 6 MH, 6 MI, 6 MN, 6 ON, 6 PF, 6 PJ, 6 PS, 6 RM, 6 WF, 6 WX, 6 WL, 6 AB, 8 AE, 8 AO.

(Norman C. Smith.)

West Norwood, S.E.27.

2 AT, 2 FH, 2 FL, 2 GG, 2 IC, 2 IT, 2 KP, 2 MC, 2 MF, 2 MG, 2 NI, 2 MK, 2 MO, 2 MP, 2 MU, 2 QH, 2 QN, 2 ACU, 2 ACK, 5 BS, 5 DA, 5 GJ, 5 LN, 5 OT, 5 RW, 5 SI, 5 TU, 5 VM, 6 GM, 6 PS, 6 UD, 8 AE, 8 AEE, 8 AG, 8 AL, 8 AP, 8 ARA, 8 AU, 8 AZ, 8 BE, 8 CG, 8 CJ, 8 CH, 8 CT, 8 CY, 8 CC, 8 DA, 8 DT, 8 DZ, 8 DY, 8 EB, 8 JL, 8 LS, 8 LY, 8 OA, 8 OB, 8 DE, 8 OFN, 8 KX, 8 MR, 8 PZ, 8 SA, 8 WZ, 8 XW, 8 YP, 8 PA, 8 ACD, 8 M, 1 MT, 7 EC, 7 ZM. (o-v-o Reinartz.)

(L. H. Thomas, 6 QB.)

Herne Hill, S.E.

2 AA, 2 AF, 2 AH, 2 AQ, 2 AU, 2 ABH, 2 BO, 2 BZ, 2 DW, 2 DY, 2 FJ, 2 FK, 2 FP, 2 FQ, 2 FU, 2 KF, 2 KT, 2 KV, 2 KZ, 2 LI, 2 LP, 2 LT, 2 LZ, 2 OD, 2 OS, 2 ON, 2 NF, 2 PE, 2 PR, 2 PX, 2 PW, 2 QI, 2 QD, 2 QQ, 2 QS, 2 SF, 2 SK, 2 SL, 2 SX, 2 TL, 2 TG, 2 TJ, 2 VH, 2 VS, 2 VT, 2 VW, 2 VL, 2 WD, 2 WS, 2 WY, 2 XB, 2 XL, 2 XR, 2 ZT, 2 YR, 2 ZE, 2 ZO, 5 BT, 5 BV, 5 CB, 5 CP, 5 DF, 5 DK, 5 DT, 5 FL, 5 HL, 5 HU, 5 IO, 5 JW, 5 KS, 5 LJ, 5 LE, 5 LP, 5 NN, 5 OX, 5 PD, 5 PY, 5 PZ, 5 QX, 5 SU, 5 UC, 5 UO, 5 VP, 5 VR, 5 WN, 5 WR, 6 AH, 6 BU, 6 DW, 6 IM, 6 KL, 6 KO, 6 MZ, 6 NK, 6 NH, 6 PS, 6 QB, 6 RJ, 6 RS, 6 TS, 6 WX, 6 XV. (o-v-o).

(L. F. Odell.)

Forthcoming Events.

WEDNESDAY, FEBRUARY 13th.

Edinburgh and District Radio Society. At 8 p.m. At 117, George Street. Lecture: "Constructional Notes." By Mr. N. V. Morrison.

THURSDAY, FEBRUARY 14th.

Institution of Electrical Engineers. (Joint Meeting with the Physical Society of London). At 6 p.m. (light refreshments at 5.30). At Savoy Place, W.C.2. Continuation of Discussion on "Loud Speakers for Wireless and other Purposes."

Hendon Radio Society. At 8 p.m. At the Town Hall, The Burroughs, Hendon. Lecture: "Thermionic Valve Manufacture and Characteristics." By Dr. C. E. Hiatt.

Dewsbury and District Wireless Society. Lecture by Mr. W. Burnett, of Sheffield.

FRIDAY, FEBRUARY 15th.

Radio Society of Highgate. At 8 p.m. At Edco Hall, Archway Road, N. Lecture: "Analogies." By Mr. E. S. Anderson.

Sheffield and District Wireless Society. At 7.30 p.m. In the Physics Lecture Room, The University, West Bank. Lecture: "Electrons and Protons—The Constituents of Matter." Dr. S. R. Milner.

MONDAY, FEBRUARY 18th.

Ipswich and District Radio Society. At 55, Fonnereau Road. Lecture by Mr. F. Mellor, A.M.I.E.E.

Kingston and District Radio Society. Lecture: "Sources of Filament Energy." By Mr. T. W. Bloxam, M.I.E.E.

Dulwich and District Wireless and Experimental Association. Demonstration: "A Transatlantic Receiver." By Mr. P. Falkner.

REGULAR PROGRAMMES ARE BROADCAST FROM THE FOLLOWING EUROPEAN STATIONS:—

GREAT BRITAIN.

ABERDEEN 2 BD, 495 metres; BIRMINGHAM 5 IT, 475 metres; GLASGOW 5 SC, 420 metres; NEWCASTLE 2 NO, 400 metres; BOURNEMOUTH 6 BM, 385 metres; MANCHESTER 2 ZY, 375 metres; LONDON 2 LO, 365 metres; CARDIFF 5 WA, 353 metres; SHEFFIELD (Relay from 2 LO), 303 metres. Regular daily programmes. Weekdays, 11.30 to 12.30 p.m. (2 LO only), 3.30 to 4.30 p.m., 4.30 p.m., 5 to 10.30 p.m. Sundays, (2 LO only), 3.30 to 4.30 p.m., 5 to 10.30 p.m. Sundays, 3 to 5 p.m., 8.30 to 10.30 p.m.

FRANCE.

PARIS (Eiffel Tower), FL, 2,600 metres. Daily, 6.40 to 7 a.m. Weather Forecasts; 10.50 a.m. (Thursday and Friday), 11.15 to 11.30 a.m., Time Signal and Weather Forecast; 12.00 noon, Live-stock prices; 3.40 p.m. (Saturday excepted); Financial report, 5.30 p.m. (Saturday excepted) Bourse Closing Prices; 6.10 p.m., Concert or Address; 7 p.m., Weather Forecast; 7.20 p.m. (Sunday), Concert and Address; 10.10 p.m., General Weather Forecast.

PARIS (Compagnie Francaise de Radiophonie Emissions "Radiola"), SFR, 1,780 metres. Daily, 12.30 p.m., Cotton Oil and Café Prices, News, Concert; 1.45 p.m., First Bourse Report; 4.30 p.m., Bourse Closing Prices; 4.45 p.m., Concert; 5.45 p.m., News and Racing Results; 8.30 to 9 p.m., News; 9 p.m., Concert; 10 p.m. to 10.45 p.m., Radio Dance Music.

ECOLE SUPERIEURE des Postes et Télégraphes, 450 metres. 9 p.m. (Sunday, Wednesday, Thursday, Friday and Saturday), Talk on Literature, Dramatic and Musical Selections. 8.15 p.m. to 9.25 p.m. (Tuesday), Morse Practice, English Lesson, Lecture and Concert.

LYONS, YN, 3,100 metres. Daily, 9.45 a.m. to 10.15 a.m., Gramophone Records.

NICE, 460 metres. 11 a.m., 5 p.m. to 6 p.m., 9 p.m. to 10 p.m. Concert and News.

BELGIUM.

BRUSSELS, BAV, 1,100 metres. At 1 p.m. and 5.30 p.m., Meteorological Forecast; 9 p.m. (Tuesday), Concert.

BRUSSELS ("Radio Electrique"), 410 metres. Daily, 5 to 6 p.m., 8.30 p.m. to 9.30 p.m., Concert.

HOLLAND.

THE HAGUE, PCGG, 1,070 metres. 3 to 5 p.m. (Sunday), 8.40 to 10.40 p.m. (Monday and Thursday), Concerts.

THE HAGUE (Heussen Laboratory), PCUU, 1,050 metres. 9.40 to 10.40 a.m. (Sunday), Concert; 8.40 to 9.40 p.m., Concert; 7.45 to 10 p.m. (Thursday), Concert.

THE HAGUE (Velthuisen), PCKK, 1,050 metres. 8.40 to 9.40 p.m. (Friday), Concert.

HILVERSUM, 1,050 metres. 8.10 to 10.10 p.m. (Sunday), Concert and News.

IJMUIDEN (Middelraad), PCMM, 1,050 metres. Saturday, 8.10 to 9.40 p.m., Concert.

AMSTERDAM, PA 5, 1,050 metres (Irregular). 7.40 to 9.10 p.m., Concert.

AMSTERDAM (Vas Diaz), PCFF, 2,200 metres, 8 a.m. and 4 p.m., Share Market Report, Exchange Rates and News.

DENMARK.

LYNGBY, OXE, 2,400 metres. 7.30 to 8.45 p.m., Concert (Sunday excepted).

GERMANY.

BERLIN (Koenigswusterhausen), LP, 4,000 metres. (Sunday), 10 to 11 a.m., Music and Lecture; 2.700 metres, 11 a.m. to 12 noon, Music and Lecture. Daily, 4.000 metres, 6 to 7 a.m., Music and Speech; 11.30 a.m. to 12.30 p.m., Music and Speech; 4 to 4.30 p.m., News.

EBERSWALDE, 2,930 metres. Daily, 12 to 1 p.m., Address and Concert; 7 to 8.30 p.m., Address and concert; (Thursday and Saturday), 7 to 8 p.m., Concert.

BERLIN (Vox Haus), 400 metres. 8 to 9 p.m. Concert.

CZECHO-SLOVAKIA.

PRAGUE, PRG, 1,800 metres. 7 a.m., 11 a.m. and 3 p.m., Meteorological Bulletin and News; 4.500 metres, 9 a.m., 2 p.m., and 9 p.m., Concert.

KBEL (near Prague), 1,000 metres. Daily, 6.20 p.m., Concert, Meteorological Report and News.

SWITZERLAND.

GENEVA, HB 1 (Radio Club de Genève). Temporarily suspended. LAUSANNE, HB 2, 1,100 metres (Monday and Wednesday), 4 p.m., Concert; 1,000 metres (Friday and Saturday), Concert.

SPAIN.

MADRID, 1,650, 2,200 metres (Irregular). 12 to 1 p.m., Tests. MADRID, PTT, 400 to 700 metres. 4 to 5 p.m., Tests.

Questions & Answers

Solutions of Readers' Difficulties

1. All questions are answered through the post. A selection of those of general interest is published.
2. Not more than four questions may be sent in at any one time.
3. Every question should be accompanied by a postal order for 1/-, or 3/6 for four questions, and by a coupon taken from the current issue.
4. Alternatively, advantage may be taken of our free service by using the free coupon. This appears in the first issue of each month, and is valid during the current week only.

“E.S.” (Lincoln) asks for particulars of an aerial inductance suitable for a 100 metre C.W. transmitter.

The aerial coil may consist of 10 turns of No. 16 S.W.G. bare copper wire, wound on a former 4" in diameter, the turns being spaced $\frac{1}{2}$ " apart. The grid coil may consist of from 15 to 20 turns of No. 22 D.C.C. on a former 3" in diameter. A tuning condenser should be connected in series with the aerial circuit.

circuit is connected a 0.00025 mfd. condenser with a switch. When the switch is open, the condenser is in series with the variometer, and the circuit may be tuned to a lower band of wavelengths than when the condenser is short-circuited. An advantage of the condenser, apart from that given above, is that the tuning is very often more selective. The variometer should be wound with a fairly heavy gauge wire, such as No. 22 or No. 20 D.C.C.

“W.G.A.” (London, S.W.7) asks questions about the Neutrodyne receiver.

We do not recommend the use of tapped H.F. transformers, owing to the variable capacity of the leads between the coil and the distributing switch. To obtain satisfactory results with such a transformer, it would be necessary to re-balance the receiver for each tapping in the transformer. For a similar reason a reaction coil should not be coupled with any of the H.F. transformers, and reaction effects should be obtained, if desired, by connecting a variometer in the plate circuit of the detector valve.

“F.V.C.” (Dover) asks (1) Whether the negative H.T. should be connected to + or - L.T., and (2) What would be the life of the grid cells used in an L.F. amplifier.

(1) It has been found by experiment that results are best when the negative H.T. is connected with negative L.T., and this system of connection is used by many of the leading manufacturers of wireless apparatus. (2) The current taken from grid batteries is so small that their life will depend more upon the amount of local action which takes place in the cell rather than on the current which it actually delivers to the receiver. Cells manufactured by reliable makers should last about twelve months.

“W.L.D.” (Weaversham) asks for a diagram of a three-valve receiver (1-V-1), using variometers to tune the aerial and anode circuits.

The diagram is given in Fig. 1. In the aerial

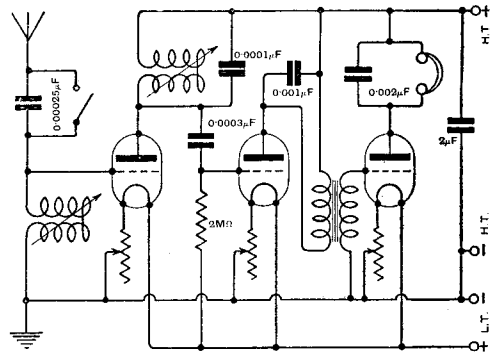

Fig. 1. “W.L.D.” (Weaversham). A three-valve receiver using variometers to tune the aerial and anode circuits.

The variometer connected in the plate circuit may be wound with finer wire, such as No. 26 or No. 28 D.C.C., and it is advisable to connect a small fixed condenser, such as 0.0001 mfd. across it. To increase the wavelength range of both variometers, it could be arranged that fixed condensers are switched in. The plate circuit variometer will require a few more turns than the aerial variometer. No reaction is shown in the circuit, but if it is desired to obtain reaction effects, a variometer may be joined in the plate circuit of the detector valve between the plate and the connection to the intervalve transformer.

THE WIRELESS WORLD AND RADIO REVIEW

THE OFFICIAL ORGAN OF THE WIRELESS SOCIETY OF GREAT BRITAIN.

No 236. (No. 21.) FEBRUARY 20th, 1924.

WEEKLY

EDITOR :
HUGH S. POCKOCK.

RESEARCH EDITOR :
PHILIP R. COURSEY, B.Sc., F.Inst.P., A.M.I.E.E.

ASSISTANT EDITOR :
F. H. HAYNES.

QUESTIONS AND ANSWERS DEPARTMENT :
Under the Supervision of W. JAMES.

CONTENTS

	PAGE
Is the B.B.C. Oscillating? By the Editor	638
A Method for Accurate Frequency Calibration. By N. V. Kipping	639
A.C. Mains for Filament Lighting and Plate Current. By E. H. Turle	641
Homodyne. By F. M. Colebrook	645
The Selection of Tapping Points in Inductance Coils. By A. H. Burnand	649
Inventions and Novel Ideas	651
Relay for Remote Control. By J. F. Payne	653
Long Distance Transmissions	655
The Amateur's Parliament	658
Correspondence	659
Around the Wireless World	660
With the Societies	663
Questions and Answers	665

THE EDITOR will be glad to consider articles and illustrations dealing with subjects within the scope of the Journal. Illustrations should preferably be confined to photographs and rough drawings. The greatest care will be taken to return all illustrations and manuscripts not required for publication if these are accompanied by stamps to pay return postage. All manuscripts and illustrations are sent at the Author's risk and the Editor cannot accept responsibility for their safe custody or return. Contributions should be addressed to the Editor, "The Wireless World and Radio Review," 12 and 13, Henrietta Street, Strand, London, W.C.2.

SUBSCRIPTION RATES :
20s. per annum, post free. Single copies 4d. each or post free 5d. Registered at the G.P.O. for transmission by Magazine Post to Canada and Newfoundland.

As many of the circuits and apparatus described in these pages are covered by patents, readers are advised, before making use of them, to satisfy themselves that they would not be infringing patents.



EDITORIAL AND PUBLISHING
OFFICES :

12 and 13 Henrietta Street,
Strand, London, W.C.2.
Telephone : Gerrard 2807-8.

ADVERTISEMENT MANAGERS :

Bertram Day and Co., Ltd.,
9 & 10 Charing Cross, S.W.1
Telephone : Gerrard 8063-8.

IS THE B.B.C. OSCILLATING?

By THE EDITOR.

THE B.B.C. is greatly perturbed at the extent of oscillation which takes place at the present time, for it interferes with the reception of the programmes and indirectly hampers the development of the industry. We wonder, however, whether the B.B.C. itself may not be accused by the industry of "self-oscillation," or at least of a state of instability in policy which deprives the industry, and particularly the manufacturer of broadcast apparatus, of confidence in the trend of future developments.

In order that a stable industry may be built up, and to ensure the satisfaction of the public, it is primarily essential that manufacturers should know exactly for what purpose their sets are to be designed. Already we have seen the disastrous effect which was produced by the early attitude of the Post Office in prohibiting, first the use of reaction in any form in B.B.C. receivers, and secondly the use of reaction to such an extent as to energise the aerial. Months were spent in research work by manufacturers in the effort to produce sets to conform to these regulations, and then what happened is common knowledge—the Post Office modified its attitude, and at the present time apparatus which complies with these regulations is obsolete, and those who purchased sets of this nature have either been compensated at the expense of the manufacturers or are disappointed unfortunates.

There must be no more "oscillation" on such points of policy in the direction of broadcast development, and probably the Post Office will refrain from any further experiments.

The position with the B.B.C., however, is different. Nobody could suggest that the B.B.C. is not progressive, and herein lies the danger to the industry. The B.B.C. should remember that it is somewhat in the position of an agent of the wireless industry as well as a public service.

Rapid changes which would affect the policy of manufacturers and the design of receivers must be avoided.

There has been a good deal of discussion over the question of wavelengths for broadcasting, yet any drastic change would affect probably every type of broadcast receiver now in use. Under these circumstances it would seem that the B.B.C. is not in a position to undertake any such change, and an assurance on this point would be acceptable to all interested in the industry. Again, the installation of a number of relay stations all over the country must affect to a considerable degree the policy of the manufacturers and retailers of sets, for the installation of any relay station in any district puts an entirely different complexion on the question of the types of sets suitable for the location.

Another matter which has been receiving consideration, we believe, is the advisability of erecting broadcast stations, limited in number, of very much greater power than those at present installed. Here once more there would have to be a general shuffle round on the part of those whose interests lie in the progress of the industry in order that the new conditions might be met.

It must not be thought that our object is to set a pace to the rate of progress of development of the Broadcast service. Our view is that the B.B.C. must remember that they are virtually trustees of one of the biggest of the electrical industries, involving a very large amount of British capital, and that whatever policy they adopt must not be departed from without adequate warning being given to every section of the industry likely to be affected by the change.

A METHOD FOR ACCURATE FREQUENCY CALIBRATION.

By N. V. KIPPING.

THE accurate calibration of a frequency, especially those which fall above the range of audibility, is a matter of some slight difficulty which ordinarily involves the use of standard capacities, inductances, etc.

The method to be described requires only a source of A.C. of known frequency of a suitable value, say 1,000 cycles per second when calibrating high frequencies, or 100 cycles for lower frequencies. It is necessary that this known source of A.C. should be of good wave-form.

The cathode ray oscillograph is used for these calibrations, and is employed in a somewhat unusual manner. To the two pairs of oscillograph plates is connected the circuit of Fig. 1 in the manner shown.

R is calculated $= \frac{I}{\omega C}$, so that equal deflections 90 degrees out of phase are obtained from the oscillograph plates. The resulting trace is a circle, assuming that the wave form of the known A.C. concerned is sinusoidal. The spot tracing the circle is, of course, rotating at a frequency equal to that of the A.C. applied.

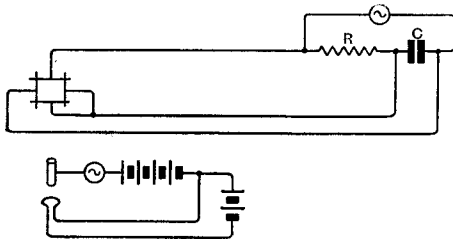

Fig. 1.

The fact is now made use of that the sensitivity of the oscillograph varies inversely with the anode voltage. In other words, the diameter of the circular trace made by the "rotator" circuit is greater with an anode voltage of, say, 250 volts, than with a voltage of, say, 300 volts.

The unknown A.C. wave is therefore superposed on the D.C. anode battery,

the two being connected in series. (See Fig. 1.) The anode voltage is now varying between two limits $A + B$ and $A - B$ where A is the D.C. anode battery, and B is the A.C. voltage of the unknown A.C. connected. This arrangement results in

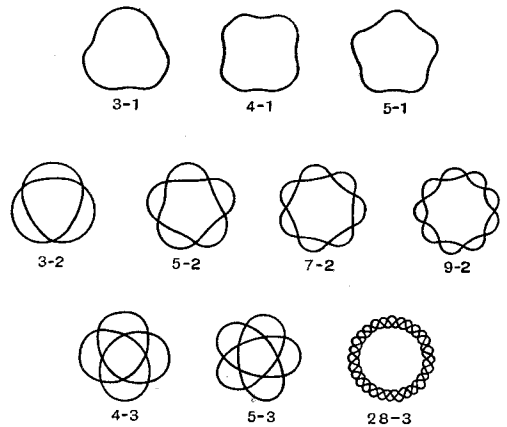

Fig. 2.

variations in the diameter of the circular trace, according to the phase at any moment of the unknown A.C. Suppose that the unknown A.C. is exactly 10 times the frequency of the known A.C. Then 10 times in each revolution of the spot, the anode voltage is $A + B$, and other 10 times in the same revolution it is $A - B$ volts. Furthermore, as the frequency relationship of the two frequencies is exactly 10-1, the places in the circular trace at which these extremes of diameter (resulting from corresponding extremes of anode voltage) occur, are the same in each revolution.

The result of this is that a gear-wheel type of trace is produced, the number of teeth to the wheel being a measure of the number of times the unknown frequency is the known frequency. Incidentally, the shape of the teeth in the wheel is dependent upon the wave shape of the unknown A.C., a nearly exact reproduction being obtained. The only distortion (given that

the known "rotating" A.C. is purely sinusoidal) is that due to the curvature of the base line, which is the normal circular trace without a superposed A.C.

By suitably changing the relationships of the two frequencies concerned, it is possible to obtain figures on the screen which are easily interpreted, such as those shown in Fig. 2, in which the relationships are indicated. The system of the tracings is obvious from these figures.

If the two frequencies do not bear exact numerical relationships to one another, the gear-wheel will appear to rotate, and the speed of rotation is a measure of the deviation in cycles, from an exact relationship. It is extremely easy to see a rotation

which would occupy as much as a minute, so that it may be said that an accuracy of 0.001 per cent. may be obtained with this method.

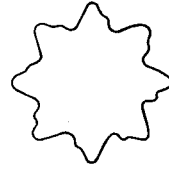

Fig. 3.

Fig. 3 is a tracing put in to show the effect obtained when the unknown A.C. is of bad wave form, and shows the adaptability of the system to wave form examination.

THE NEED FOR AN INTERNATIONAL RADIO LANGUAGE.

By HARRY A. EPTON, F.B.E.A.

(Chairman of the Hackney and District Radio Society.)

WHETHER a radio relay service can be successfully organised in this country on the lines of the American Radio Relay League is open to question, one objection being that Great Britain is too small to make such a service really effective, while the vast spaces of the American continent provide ideal opportunities for relaying. No such objection, however, can be raised to the organisation of a relay service in Europe, and, for that matter, the inclusion of Asia and Africa should not be left out of consideration.

The time is fast approaching when definite steps must be taken to form an International Radio Relay League with branches in every quarter of the globe. If such an organisation were in the hands of men like K. B. Warner (U.S.A.), Philip Coursey (Great Britain), and Dr. Pierre Corret (France), all of whom were intimately connected with past and the recent Transatlantic amateur tests, there is little doubt that it would prove of great benefit to all interested in the development of radio.

But however well organised an international league may be, one very serious obstacle to its rapid development must first be overcome—the diversity of languages. For those amateurs whose ambition is limited to communication with one other country, e.g., France, the solution is comparatively simple—learn French (though it will need years of study!), but for those who wish to include in their range countries such as Denmark, Holland, Czechoslovakia, Germany, Spain, etc., some other solution must be found which will not necessitate the study of several languages.

One language must be adopted as a common radio language, to be used by all for international purposes. We have the choice of one of the national languages, of a "dead" language, or of an

"artificial" language. National languages must, in spite of sentiment, be ruled out on account of grammatical difficulties and national jealousies. As regards a "dead" language, who can make the dead bones live? To modernise Latin would be to murder it!

We are therefore driven to consider a language which shall be equally acceptable to all nations. Esperanto at once leaps to the mind as the ideal common language for radio. It has the best qualities of national languages with none of their defects, it is simple and regular, has few rules, no exceptions. It is a living language in daily use by many thousands of people throughout the world.

Here, then, is the solution of the language difficulty, and here lies the means of overcoming the one great obstacle to the rapid development of radio. With the language barrier overcome there is nothing but the range of their instruments to prevent amateurs in this country from exchanging messages with others in every country in the globe, each one on an equal lingual footing.

The time is quickly approaching when an international radio relay organisation will be formed. Let us hope that amongst its founders will be men like Dr. Corret, who is already an Esperantist of note, men who will sympathetically consider the tackling of the language difficulty and not rely on the antiquated methods of interpreters and translators for their international communications.

The success of such an organisation will thus be assured.

Editor's Note.—Information with regard to Esperanto may be obtained from the Secretary, The British Esperanto Association, Inc., 17, Hart Street, London, W.C.1.

A.C. MAINS

FOR FILAMENT HEATING AND PLATE CURRENT.

By E. H. TURLE, A.M.I.E.E.

IT is of first importance with valve sets, to have sources of H.T. and L.T. current that shall be both invariably available, and further, of constant voltage within narrow limits. Provided access to alternating current supply mains can be arranged there need be neither difficulty nor expense in accomplishing this.

For the H.T. or anode current provision should be made for the maximum number of valves ever in use at 1.5 milliamperes per H.F. valve plus 2.0 for the detector valve and for each L.F. valve, if of the ordinary "R" type, 2.5, but this last figure should be increased two or three times if L.F. valves of the power type such as "L.S.3," or similar, are used. With a set comprising seven "R" valves (4-v-2), this only totals 13.0 milliamperes, and under usual conditions is actually far less. Allowing for an average use equivalent to three valves for 40 hours per week, this gives a net capacity of 0.22 ampere hours.

A voltmeter, however, is almost a necessity, and this should be of the moving coil type and preferably read from 0-130 volts. The current consumption of a voltmeter of this range being no less than about 50 milliamperes, allowance must be made in the H.T. service accordingly, but as there is no need to have it continuously in circuit provided it is available at any instant by merely closing a switch, an increase from 0.22 to about 0.3 ampere hours per week should suffice.

This is a very small amount of current, and being spread over a period of 40 hours it is not practicable to draw it from the A.C. supply as and when it is required, except at a very low overall efficiency, and also the necessity of eliminating the A.C. hum is rendered more difficult so that the final efficiency is usually less than 0.5 per cent. This difficulty can be met by employing a block of H.T. accumulators of very small capacity, and providing for recharging them in a manner obviating any need for interruption of reception while so doing. A type comprising thirty $\frac{1}{2}$ in.

diameter tubes recessed into a block of wood impregnated with paraffin wax will suffice, is obtainable at a similar cost to good dry cells and such 60-volt units have a capacity of about 0.5 ampere hours. Preferably there should be two or three of these units, particularly if a loud speaker is to be used, and with some types of power valves requiring high anode potentials, it may be desirable to have three or even four of such units. Two units will give a normal working voltage range up to 120 volts, available in steps of approximately 2 volts. The A.C. voltage required for charging this H.T. accumulator battery should be 100 multiplied by the number of 30 cell (60 volt) units, and if this does not coincide

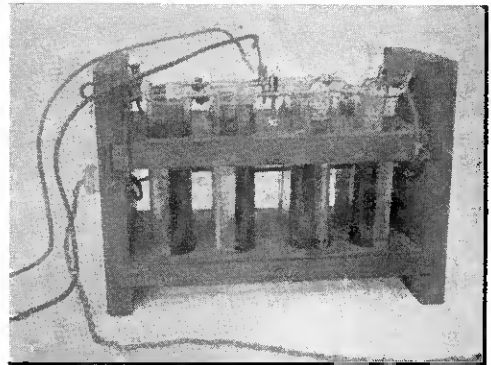

Fig. 1. The rectifier for obtaining H.T. from A.C. mains, consisting of boiling tubes carrying electrodes of lead and aluminium and containing a solution of ammonium phosphate. The liquid is covered with a layer of paraffin.

with the voltage of the supply available, a suitable transformer—preferably double-wound—must be procured or made up, to step up or down as may be required.

Fig. 1 shows a simple type of rectifier for converting the alternating current into direct current pulsations. constructed from $1\frac{1}{2}$ in. diameter by 6 ins. hard glass test tubes (boiling tubes) spaced apart and arranged in two rows. In each test tube are two electrodes, one cut from sheet lead (12 gauge) to form a plate $5\frac{1}{2}$ ins. by $2\frac{1}{2}$ ins.

wide, and bent into a semicircle to fit round the inside, with a $1\frac{1}{2}$ in. by $\frac{3}{8}$ in. wide connecting strip extending from the top and a second electrode comprising a strip 7 ins. by $\frac{3}{8}$ in. wide, cut from pure aluminium sheet (10 gauge). The electrodes must be

monium phosphate (neutral) $(NH_4)_2HPO_4$ as will dissolve (1 in 4) in perfectly cold water, and finally a 1 in. layer of clean paraffin (kerosene) is superimposed. The electro-chemical film which functions by allowing the alternating current to pass only in one direction, is first formed at a slow rate by connecting the A.C. supply to the rectifier through a lamp L^1 (Fig. 2) as a resistance by keeping switch S^1 open. This forming process is continued for six hours, keeping the D.C. side of the rectifier on open circuit except for the voltmeter V shown, which will give an appreciable reading. The forming is concluded for a further period with S^1 closed, until the voltmeter reads 1.4 times the voltage of the A.C. side, when the active hydrogen film will be complete on the plates of the rectifier.

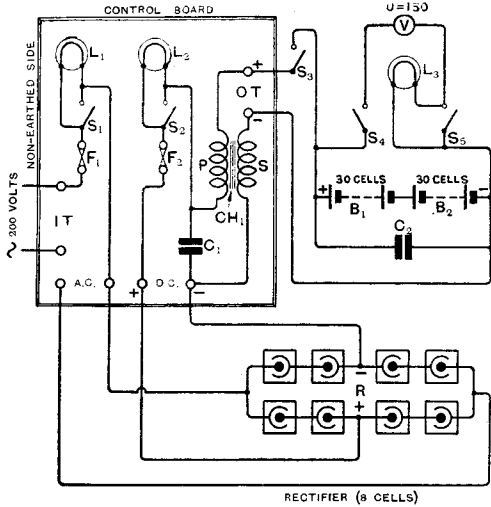

Fig. 2. Connections of apparatus for deriving H.T. from A.C. mains. L^1 , lamp 200 volts 60 watts. L^2 , lamp 100 volts 30 watts. F^1 , fuse No. 40 S.W.G. tin-lead. F^2 , fuse No. 46 S.W.G. tin-lead. C^1 , condenser 4 mfd. C^2 , condenser 2 mfd.

arranged as shown diagrammatically in Fig. 2, which also shows the whole of the electrical connections between the components.

The test tubes are filled to within 2 ins. of the top with a solution of as much am-

monium phosphate (neutral) $(NH_4)_2HPO_4$ as will dissolve (1 in 4) in perfectly cold water, and finally a 1 in. layer of clean paraffin (kerosene) is superimposed. The electro-chemical film which functions by allowing the alternating current to pass only in one direction, is first formed at a slow rate by connecting the A.C. supply to the rectifier through a lamp L^1 (Fig. 2) as a resistance by keeping switch S^1 open. This forming process is continued for six hours, keeping the D.C. side of the rectifier on open circuit except for the voltmeter V shown, which will give an appreciable reading. The forming is concluded for a further period with S^1 closed, until the voltmeter reads 1.4 times the voltage of the A.C. side, when the active hydrogen film will be complete on the plates of the rectifier. The rectifier is henceforward ready for charging the H.T. battery, it only being necessary to close switch S^3 . The charging rate will slowly fall as the voltage of the H.T. battery rises, but when the filament of L^2 has sunk to a barely visible dull red glow, the charging rate may be usefully raised by closing S^2 . Charging is terminated by opening the switches in precisely the reverse order, and so preventing the H.T. battery from discharging through the rectifier.

To eliminate the A.C. hum, a condenser and a small choke coil (e.g., the induction coil from an old telephone instrument) is inserted as shown in Fig. 2. The choke should preferably pass 0.1 amperes, but must not be so large as to reduce the current below 0.03.

TABLE I.

No. of cells.	A.C. volts required. (R.M.S.)	No. of cells in rectifier.	Quantity of Solution. (Pints.)	Voltage of resistance lamp in series, on D.C. side. (30 watt.)	Input. (Watts.)	Output. (Watts.)	Efficiency. %	Voltage available for H.T. (D.C.)	
								Normal	Max.
30	100	4	0.75	50	28	10	36	60	84
60	200	8	1.5	100	59	19	32	120	165
90	300	12	2.1	120	84	28	30	180	247
120	400	16	2.8	200	121	35	29	240	330

Electrode area of immersion. Anode (aluminium) 1.0 sq. in.
Cathode (lead) 11.0 sq. in.

Normal current (D.C.) 0.1 ampere.

Table I gives some further data relating to these rectifiers.

Instead of a high-reading voltmeter it is more useful to have one reading only to say half the maximum, and by inserting a lamp L^3 (Fig. 2) and switch S^5 as shown, two scales are available. The lamp is selected by trial so that the reduced reading obtained when it is in series is some convenient fraction of the figured scale such as a half or one third. With S^5 closed the lamp is bridged and the voltmeter reads normally.

The electrolytic solution does not require replacing under six months, and when renewed the forming process is repeated for a short period. The electrodes last indefinitely.

For the L.T. or filament current provision should similarly be made for the maximum number of valves ever in use, at 0.67 amp. per "R" valve, and for a seven-valve set this gives a demand up to a maximum of 4.7 amperes.

Several important points require careful consideration. There is first the necessity of invariably obtaining this current at an extremely steady voltage, and the difficulty of this when the maximum demand exceeds the minimum by 600 per cent, and while the supply is also liable to vary in voltage. Then there is the impracticability of drawing this from the mains as and when required, at reasonably good efficiency, and eliminating A.C. hum over such a range and varying current output. Finally the provision of a stand-by source or reservoir.

No one of these requirements presents difficulty if an accumulator of suitable capacity is utilised, together with means for recharging it in a manner obviating any

need of interruption in reception. The capacity of the accumulator may well be based on the 20-hour rate of discharge in the case of three or four-valve sets, and on the 16-hour rate above this, in view of the lower diversity factor likely to obtain. For seven "R" valves the calculated capacity is $(7 \times 0.67 \times 16) + 5$, the latter addition being for two potentiometers, making a total of 80 ampere hours.

The provision for recharging this is described below, and data for both this and other sizes is given in Table II.

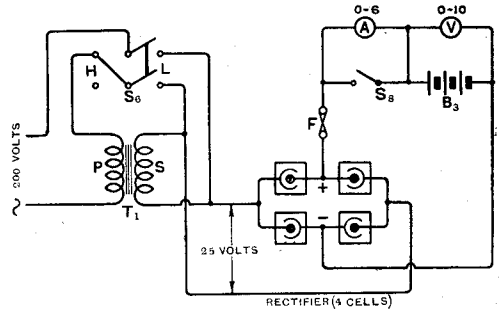

Fig. 3. Circuit of rectifier for giving filament heating current. F, fuse No. 18 S.W.G. tin-lead. S^3 , switch wired with No. 26 D.C.C. to form convenient shunt.

A double-wound transformer of about 0.25 Kw. is used to reduce the voltage of the A.C. supply to 25 volts, and is connected as shown diagrammatically in Fig. 3. The rectifier requires four stoneware jars each of about 2½ to 3 gallons capacity, and in each of these is an electrode 7 ins. by 9 ins., or equivalent area, cut from sheet aluminium (No. 10 gauge) with a suitable

TABLE II.

Capacity of Accumulator ampere hours (at 10 hour rate).	No. of valves usefully fed.	Open circuit Voltage output of transformer secondary. (R.M.S.)	Electrode area of immersion (square inches).		Quantity of electrolytic solution required. Gallons.	Input at the working voltage. Watts.	Output at 8.3 volts. Amperes	Efficiency of Rectifier %
			Aluminium.	Lead.				
40	3 R	35	26	36	3.5	83	4.0	41
80	7 R	27	56	85	8	170	7.5	38
120	5 R + 2 potentiometers.	22	100	160	14	265	11.5	36

length of 1 in. wide connecting strip extending from the top and also an electrode $9\frac{1}{2}$ ins. by 9 ins., or equal, cut from sheet lead (No. 12 gauge), with a similar connecting strip.

The internal resistance must be reduced to a minimum so that the rectifier may operate without appreciable heating, for this, if not freely dissipated by convection within the liquids will itself increase the resistance, giving rise to further heating, and a vicious cycle is set up.

The aluminium electrode is bent to form a cylinder of $2\frac{1}{4}$ ins. diameter, and this is surrounded by a sheet of the wood separators specially prepared for accumulators and procurable from their makers. These separators are

about $\frac{1}{16}$ in. thick, and are best handled in a well water-soaked condition. The lead electrode is finally wrapped round the two, so that the two electrodes are virtually separated only by $\frac{1}{16}$ in. of water-logged wood.

In view of the quantity of ammonium phosphate required and the cost

(3s. 3d. per lb.) of the neutral salt, the commercial quality of this salt is used dissolved in perfectly cold water and carefully strained. Eight gallons will suffice for over 3,000 ampere hours. Finally a layer of half a gallon of clean paraffin is floated on the top of the solution in each jar, or even a gallon in each should space permit.

Before the rectifier will function the requisite electro-chemical film must be formed under application of the alternating current (at 25 volts). The rectifier will be more efficient if the forming is conducted at a slow rate. For the first hour a lamp should be used as a resistance in series to check the first rush and the full 25 volts applied for at least six hours continuously thereafter. Nothing beyond a voltmeter may be con-

nected on the D.C. side meanwhile, and this should finally read 32 to 35 volts, while on open circuit. If desired, a higher voltage up to 110 volts A.C. may be finally applied to ensure that the film formed on the electrodes is complete. Charging is started by closing S^6 (Fig. 3) at H , and usually commences at about 3 amperes, gradually increasing to about 10 amperes, but can be reduced by throwing S^6 over to position L , and the accumulator is benefited by reducing the rate as soon as gassing commences. In hot weather the current passed by the rectifier is somewhat increased, and in cold weather the reverse, but as portable accumulators have pasted plates a rate as low even as 1 ampere would recharge if continued

without intermission for 80 hours. The electrolyte never rises above tepid temperature, but nevertheless, loss by evaporation and electrolysis occurs, and should be replaced by adding only water during the period summer to winter, and only paraffin during the winter to summer period.

The ammeter in Fig. 3 has its

terminals bridged by a switch S^8 connected by No. 26 D.C.C. wire of a length selected by trial so as to cause the readings to be exactly halved when the switch is closed. Thus two scales are available, 0 to 6 and 0 to 12 amperes.

The photograph, Fig. 4, shows both rectifiers in service, the large four-cell L.T. on the floor with the transformer in the corner, and the eight-cell H.T. rectifier hung under the shelf with its control board to the left and the accumulators to the extreme right.

The above system is not expensive to install or maintain, and by means of it a consumption of 100 ampere hours L.T. and 1,000 milliampere hours H.T. are available at a total cost of fourpence where the supply is at twopence per B.O.T. unit.

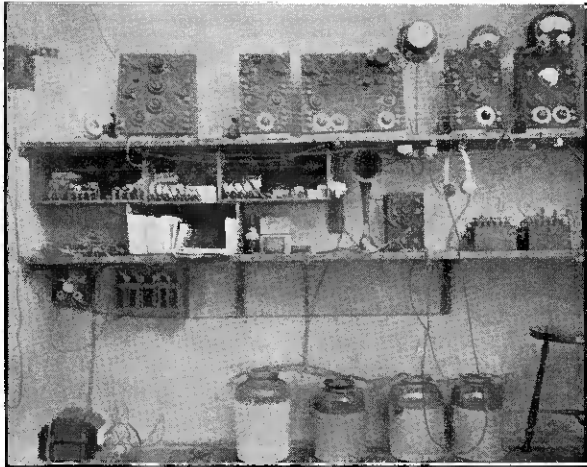

Fig. 4. The complete rectifying outfit in use.

HOMODYNE.

An interesting article dealing with the theory of telephony reception with an oscillating receiver.

By F. M. COLEBROOK, B.Sc.

THE principle of homodyne reception is not new. It is not, however, a matter of general knowledge and it will therefore be well to preface this practical paper on the subject with some account of its theoretical basis.

It can conveniently be explained by reference to the ordinary heterodyne wavemeter. It was, in fact, as a result of thinking about the heterodyne wavemeter that the writer was led to consider the possibilities of homodyne reception for wireless telephony in general and broadcasting in particular.

There are, of course, various forms of heterodyne wavemeter, but they all consist essentially of a valve maintained oscillating circuit of variable wavelength with telephones inserted in the anode circuit of the valve. This combination is placed near the apparatus in which are occurring the oscillations whose wavelength is to be determined and the wavemeter circuit is then tuned until the heterodyne beat note produced by the action of the unknown oscillations on those produced by the wavemeter is heard in the telephones. When the wavemeter is exactly tuned to the source, the beat note disappears, but will be heard again as a note of ascending pitch as the wavemeter is slightly detuned in either direction.

What is the explanation of this note, and why does its central disappearance point indicate the exact tuning of the wavemeter? The explanation is simple and well known. Suppose the oscillations of unknown wavelength to have a frequency of m cycles per second, and those of the wavemeter to have a frequency $m + n$ cycles per second. Forced oscillations of frequency m are induced in the wavemeter circuit by the source, and the combination of this forced oscillation with the valve maintained oscillations of frequency $m + n$ produces, in effect, a high frequency oscillation of $m + n$ cycles whose amplitude varies between a maximum and a minimum

n times per second. In itself this is not sufficient to account for the low frequency note of n cycles which is heard in the telephones. The high frequency oscillation of varying amplitude in the wavemeter circuit is however the direct cause of the note, on account of the fact that the value of the continuous anode current of the valve varies with the amplitude of the oscillations in the attached wavemeter circuit. Since this amplitude varies between a maximum and a minimum n times per second the continuous component of the anode current varies between a maximum and a minimum with the same frequency, and since this anode current passes through the telephones it produces in them a note of n cycles. As the wavemeter is brought nearer and nearer into tune with the source, the value of n becomes smaller and smaller, *i.e.*, the

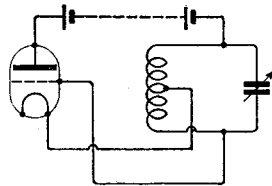

Fig. 1.

audible note becomes lower and lower in pitch. Finally it will fall below the limit of audibility and disappear. In the centre of the tuning range, at either end of which the note is just audible, the wavemeter is exactly tuned to the wavelength of the source.

Now, keeping the wavemeter tuned to this condition, suppose the oscillations from the source to be modulated in the ordinary wireless telephonic manner with a pure tone of f cycles per second. It can be shown that the source will then, in general, emit three wavelengths, the main oscillation or carrier wave of frequency m , and two other waves of frequency $m + f$ and $m - f$ respectively. Each

of these last two will combine with the wavemeter oscillations of frequency m and give rise to an amplitude variation or beat with a frequency f , and, as already explained, a note of this frequency will be heard in the telephones. Similarly, if the high frequency oscillations of the source are modulated by speech waves, these same speech waves will be heard in the telephones. In fact, the tuned oscillating wavemeter circuit, used in this way, filters out the carrier wave and leaves the modulation.

This is, briefly, the principle of homodyne reception, and we are now in a position to consider its practical application as a receiving circuit for broadcasting.

It is clear that the chief requirement is a valve maintained oscillating circuit possessing the characteristic that the continuous anode current shall vary steeply and, if possible, in a straight line manner, with the amplitude of the oscillation. There are two such circuits which fulfil these conditions to a satisfactory degree. One is usually, though perhaps incorrectly, named the Hartley Circuit. This is illustrated in Fig. 1. The other is the familiar arrangement shown in Fig. 2, in which an oscillatory circuit is connected to the grid and oscillations maintained by means of a reaction coil in the anode circuit. The latter is the more convenient of the two for the present purpose, but with either it is possible to obtain a curve of the type shown in Fig. 3 as the relation between the continuous anode current and the magnitude of the oscillating current.

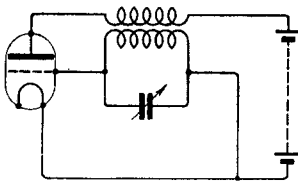

Fig. 2.

In connection with this curve, a special feature of this type of reception should be noted, namely that the equivalent of rectification is produced on a straight line characteristic, thus eliminating the curved characteristic and consequent distortion of other methods of rectification. It was in fact noted and confirmed by independent observers that in the final and successful circuits the quality of the reception was very full and rich in tone.

The writer's first experiment consisted in receiving London broadcasting on a small frame aerial which was itself used as the generating circuit for the local homodyne oscillations. It took the form of a small square frame with a side of only 1 ft. 6 ins., carrying two separate windings of three

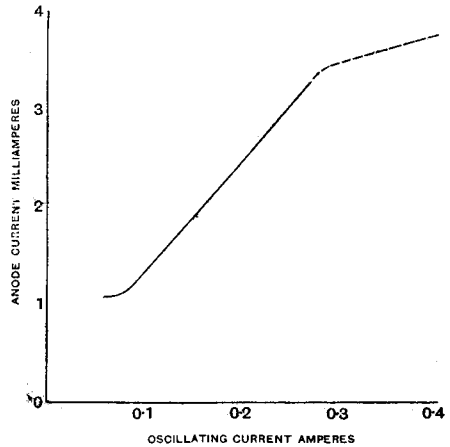

Fig. 3.

turns each. The number of turns was deliberately kept as small as possible so that the tuning capacity should be comparatively large, thus minimising the effect of stray capacities on the wavelength. Figs. 1 and 2, with condenser shunted telephones inserted in the anode circuit, can be taken as illustrations of the circuits which were actually used, with a dull emitter valve and an anode potential of fifty volts. In the second case one of the windings on the frame formed the oscillating circuit, the other serving as the anode reaction coil.

From the point of view of sensitivity the results obtained were astonishing, for with a single valve and the six turns on an eighteen inch frame, London broadcasting was clearly audible at a distance of about twelve miles from **2 LO**. At the same time, however, an apparently serious defect of the method made itself obvious. It is clearly necessary that for successful reception by the means described, both the local oscillation and the carrier wave must remain very constant in frequency. In practice it was found that neither of them was perfectly constant, though the broadcasting carrier wave was found to be remarkably good in this respect. It is

interesting to note that distortions of a most unusual character will result from a deviation in frequency on the part of either the carrier wave or the local oscillation. Referring back to the case of the pure tone of frequency f already considered, it is clear that if the local oscillation has a frequency $m+n$ instead of m , then in place of the single beat tone of frequency f there will be heard in the telephones two notes of frequencies $f+n$ and $f-n$ respectively. Extend this to the reception of speech or of music, and it will be realised that a very slight distuning of either the carrier wave or the local oscillation will convert a tenor solo, for example, into something not unlike a discordant duet between a bass and a soprano! Such effects were observed. In fact, the refinement of tuning required by the circuit made it very difficult to avoid them.

This trouble seemed to be inherent and unavoidable, and the writer felt correspondingly discouraged, until it was suggested by a colleague that by making the incoming oscillations sufficiently powerful and the local oscillations relatively weak, the former could be persuaded to, as it were, take hold of the latter, control them, hold them in step and make them follow their own slight variations of mean frequency. The corresponding phenomenon in the case of the heterodyne wavemeter is the well-known fact that if too close a coupling exists between the source to be measured and the wavemeter, the heterodyne note may not be heard at all because the more powerful oscillation of the source drags the wavemeter oscillation into tune with itself and holds it there.

The writer's next experiments were therefore based on a standard aerial, some small tuning coils of the ordinary honeycomb type, and one of the usual forms of three coil stands. The circuit employed is illustrated in Fig. 4. It is seen to differ from the ordinary valve detector with reaction only in the tightness of the anode reaction, which must be sufficient to produce and maintain oscillations in the grid circuit, and in the fact that there is no grid condenser and grid leak such as would be required for the usual method of rectification. The manipulation of the circuit is as follows: Tune the aerial coil and couple it not too closely to the oscillating combination formed

by the other two coils, which are coupled as closely as possible. Now tune the oscillating circuit till the heterodyne beat is heard quite loudly in the telephones, due to the combination of the local oscillation and the carrier wave. As the tuning of the local oscillation approaches that of the carrier wave it will be noticed, if the aerial coupling is about right, that as the heterodyne note becomes lower in pitch, it also develops a harshness in quality. When the oscillating circuit is brought right into tune, the harsh note of the heterodyne beat will disappear suddenly and full-toned reception of the modulation will take its place. The aerial coupling and the tuning of the oscillating circuit can now be varied to the best conditions and it will be found that there is now no tendency for the two oscillations to separate at all. The stability of the combination is in fact quite striking. The tuning of the local oscillation becomes very like the meshing of two gear wheels—a grind, one can almost imagine a click—and the two are locked together in mesh.

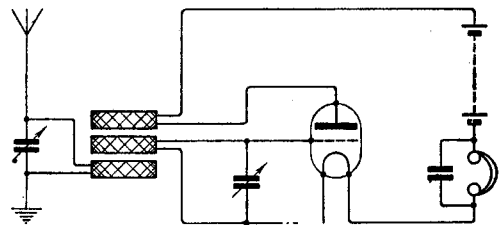

Fig. 4.

If there is any difficulty in establishing this condition it means that the local oscillation is too powerful and should be weakened either by inserting resistance in the oscillating circuit or by loosening the reaction, or both.

The quality of the reception on this circuit has been mentioned already. It will be found to be very rich and full toned. As far as intensity is concerned, it will be found on inserting an ordinary grid leak and condenser arrangement in the grid circuit and suitably modifying the anode potential and loosening the anode reaction to just off the oscillating point that the homodyne circuit under normal conditions will give a perceptibly greater intensity than a single rectifying valve with the maximum permissible reaction.

It may be objected against the simple homodyne circuit described above that it involves the coupling of an oscillating circuit to the aerial. So indeed it does, but it must be remembered that a necessary condition of the operation of the circuit is that the oscillation induced in the aerial shall be of sufficiently small intensity to be completely controlled by the carrier wave of the received transmission. The perfect synchronism thus automatically maintained is a guarantee against the possibility of interference with neighbouring aerials. The circuit is in fact less likely to cause interference than direct reaction on to the aerial which has now been made permissible.

The above is of course only an outline of the homodyne circuit and its application. Further developments can be left to experimenters. In cases where the aerial received oscillations are not sufficiently powerful to control the local oscillations a preliminary stage of tuned anode high frequency amplification can be employed as shown in Fig. 5. The writer's experiments were carried out

at a distance of about twelve miles from **2LO** with a not particularly efficient standard aerial and under these conditions the received strength was ample to control the local oscillations and to give comfortably loud

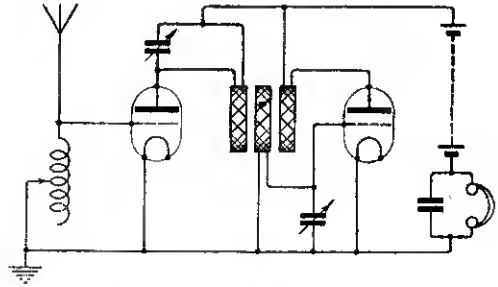
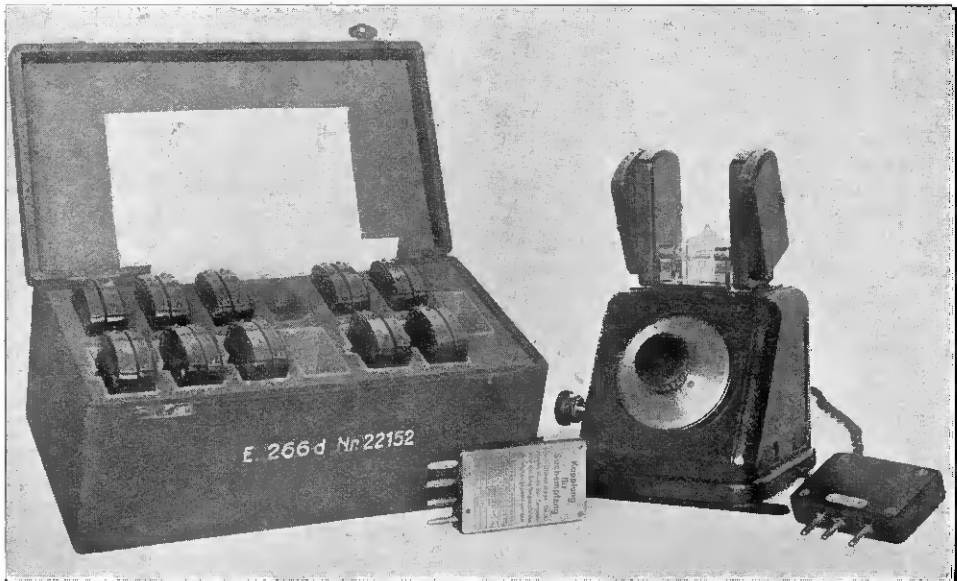

Fig. 5.

reception in head telephones, or, with one stage of low frequency amplification, medium intensity on a loud speaker.

With this introduction the writer leaves the subject in the hope that further applications will be found for a principle that appears to him to be rich in possibilities.

COMPACT VALVE RECEIVER.



Aerial and plate circuit tuning is effected by interchangeable folding variometers and a variable condenser. Filament current is regulated by means of a barretter tube. The valve is protected by being partially enclosed and the body of the instrument is of pressed metal.

THE SELECTION OF TAPPING POINTS IN INDUCTANCE COILS.

By A. H. BURNAND, A.M.I.Mech.E.

WHERE an inductance coil of the solenoid type is intended to be used without a condenser, it is customary to provide tapings at uniform intervals of 10, 12, or even 20 turns or more, according to the range of wavelength to which the coil can be tuned, in conjunction with a group of closer tapings for fine tuning at intervals of 1, 2, or 3 turns.

If a variable tuning condenser of even a small range is employed in conjunction with the coil, the above arrangement is both unscientific and—because it involves an unnecessary number of tapings with corresponding “capacity” and “dead end” effects—objectionable also.

The following method provides a minimum number of tapping points for a given range of adjustable condenser, and, provided a certain marginal value of the latter is left, ensures a suitable degree of “overlap” in the tuning at each stud so that the whole of the coil can be utilised without gaps.

In the accompanying graph for a coil of just over 200 turns, wavelengths are plotted in relation to number of turns in the solenoid, curves of two sets of values A and B being indicated. Curve A is derived from a constant minimum amount of capacity in parallel (for example 5 per cent. of the total capacity of the variable condenser) and curve B from a constant capacity which may be 80 per cent. to 90 per cent. of the condenser capacity, according to the marginal values allowed at each end of the condenser and the degree of overlap desired at each tapping.

Starting at the last turn of the solenoid it will be seen that C on curve A indicates the least wavelength obtainable with the margin allowed for the condenser, while the point D, on curve B, similarly represents the maximum wavelength.

By projecting the point C horizontally to meet the curve B at E, and then projecting the latter vertically to F on the base line O-X, it will cut the curve A at G,

and will indicate the number of turns at which the first tapping should be made, and also the two wavelengths obtainable at the tapping with the least and with the greatest permissible capacities respectively. Obviously the particular wavelength indicated at E on curve B, and at C on curve A is obtainable, either from the tapping at F or at the end of the coil corresponding to C, one position involving the least amount of capacity and the other the greatest.

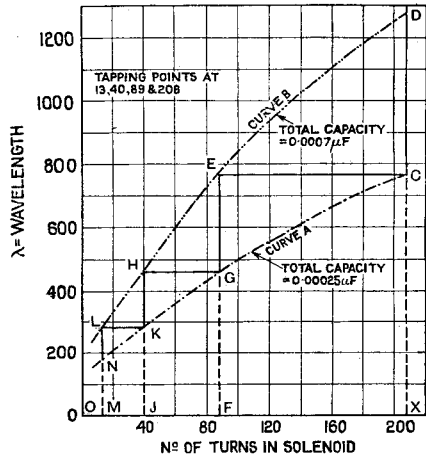

By an extension of this method the remaining tapping points F, J and M are readily found, and unless it is desired to provide for very short wavelengths, it is not generally necessary with the usual aerial capacity to employ a tapping lower than the 20th turn.

It is interesting to note that three tapping points only are necessary for a coil of this number of turns, although fifteen or twenty would ordinarily be made. The range of condenser employed is of the order of 0.00045 μF which leaves a wide margin on the usual size employed of 0.00075 μF

One other matter only needs consideration, namely the plotting of the curves A and B. To the scientific experimenter no insuperable

difficulty arises, for, from the formulæ available in the various textbooks, plus a knowledge of the user's aerial capacity and that of the tuning condenser employed, the required wavelength values are easily obtainable.

In the "Year-Book of Wireless Telegraphy and Telephony" is a table of solenoid inductances for diameters of 4 to 9 centimetres, and up to 340 turns spaced at 10 turns per centimetre. Corresponding wavelengths can be found from the fundamental formula—

$$\text{Wavelength} = 1885 \sqrt{L \times C}$$

and it is not difficult by actual trial to determine the aerial capacity, and to calculate, if not to calibrate the tuning condenser.

In the example from which the accompanying graph is obtained, the coil has a mean diameter of 6 centimetres, there are just over 200 turns, and the spacing is slightly more than 10 turns per cm., the actual length being 19 cms. Theappings embrace the 40th turn, which was used initially for determining from trial on a broadcast station wavelength the total capacity in parallel, and from this the aerial capacity plus the self-capacity of the coil was deduced.

It should be pointed out that the foregoing method is of particular service in providing tapping points for a tuned anode coil intended to cover the full range of wavelength in use, the variable tuning condenser being kept at as small a value as possible, conducive with the permissible number of

tappings. It provides also a convenient method of arranging theappings of a honeycomb plug-in coil, and by its use the correct number of turns can be found for each of a set of basket or slab coils of progressively increasing size. Such coils are well known on the market and are usually connected in series to tune to the higher wavelengths, and if correctly proportioned their junctions may also be the tapping points.

A USEFUL CONDENSER TIP.

An easy method for connecting the aerial condenser in series or parallel is shown in the accompanying diagram. It obviates the use of switches, is very easily fitted to a panel, and occupies very little space.

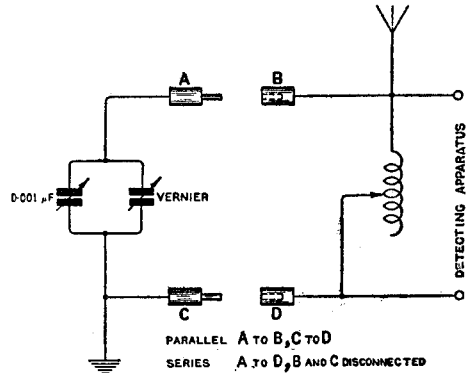

Simple method for connecting the aerial tuning condenser in series or parallel with the inductance.

A pair of valve legs may be attached to the face of the instrument and connected in parallel with the aerial tuning inductance. Two wander plugs connected across the aerial tuning condenser will serve to connect it either in series or parallel, though the earth connection is picked up from the condenser instead of the tuning inductance of the receiving set.

W.R.S.

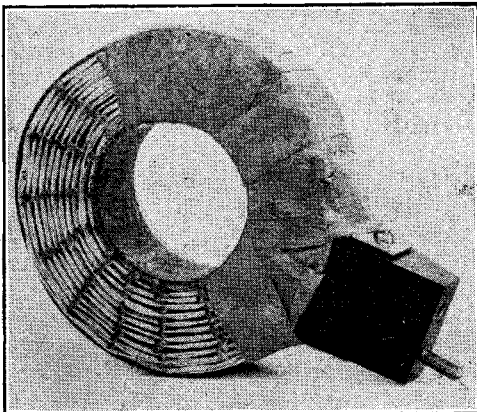

An "Atlas" coil with portion of protecting wrapping removed.

AN AIR SPACED COIL.

Wound with stranded wire and spaced layer by layer is a good feature in the design of the coil shown in the accompanying illustration. String, which has, of course, very low dielectric properties, is zigzagged across the windings and the projecting loops cut away producing a practically air spaced coil.

The windings are protected in the usual manner by wrapping with empire cloth strip, and impregnation with insulating material is not resorted to.

INVENTIONS AND NOVEL IDEAS

Duplex Radio Telephony.

Many schemes have been proposed from time to time for duplex radio telephony. In one arrangement* messages are sent and received without the use of a change-over switch. The transmitting circuit can consist of a suitable inductance and capacity joined to a three-electrode valve for the production of oscillations, the oscillations being modulated by another valve so as to render the aerial quiescent at times when the oscillations are not being modulated. In series with the aerial circuit is connected a tuned circuit consisting of inductance and

It is said that with the arrangement described, messages may be transmitted and received at the same time on the same aerial with only a small difference in the wavelength.

Referring to Fig. 1, the aerial 1 is connected to the tuning condenser 2 and the inductance 3, tuned to the transmitting frequency in series with a capacity 4 and inductance 5, tuned to the same frequency so as to obtain nodal points of potential at 6 and 7; 8 is a blocking condenser. Across the inductance 3 is a valve 9, which is connected to a control valve for quiescent

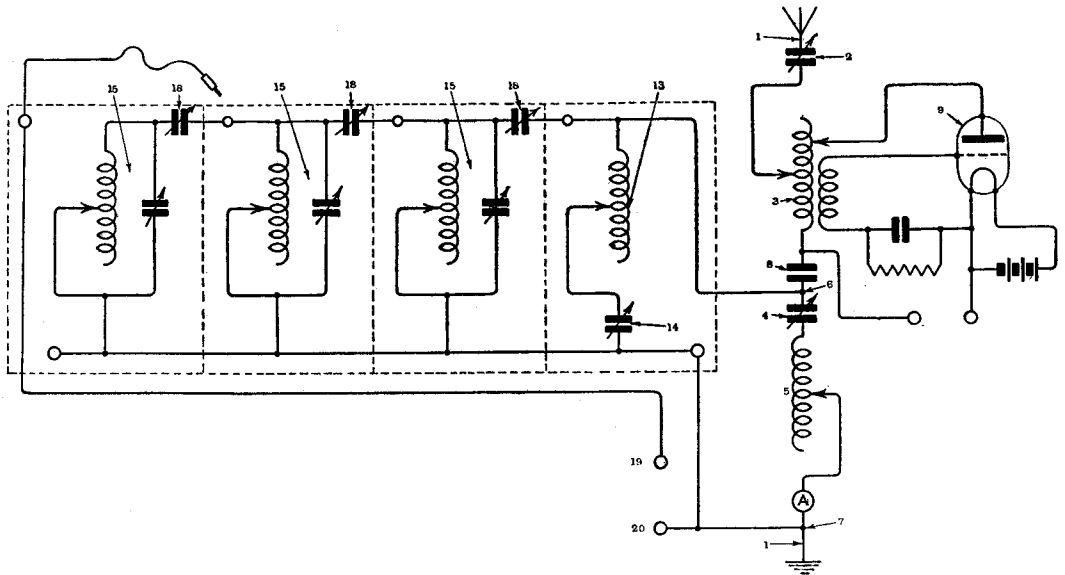

Fig. 1.

capacity in series with the same value as those of the transmitting circuit, and a receiving circuit is directly connected across this capacity and inductance.

The receiving circuit consists of a tuner suitably screened, and containing one or more circuits so designed as to provide a high degree of selectivity, and an amplifier with at least one stage of H.F. and one of L.F. amplification.

working. A receiver is connected across the nodal points 6 and earth. The receiver consists of a resonant circuit 13, 14, and a number of filters 15, electrostatically coupled by condensers 18. The amplifier is connected across the terminals 19, 20.

Variable Condensers.

It is well known that the capacity of a condenser can be varied by altering the distance between the plates forming the

* British Patent No. 208,848, by H. J. Lucas and A. J. Hurst.

condenser. One method* is to have two plates arranged so that their surfaces are opposite and parallel to each other, and can be moved to any desired separation by means of a screw or other convenient mechanism. The two plates are connected electrically together and form one plate of the condenser. The other plate of the condenser consists of a plate held approximately midway between the above two plates by a suitable arrangement of springs, being insulated from one or both sides of the condenser. In one construction, the centre plate is constructed of springy material such as phosphor bronze, shaped to provide fingers which provide the springy element referred to.

Referring to Fig. 2, AA are fingers set upwards, and BB the fingers set downwards. The ends of the fingers bear on mica or other

to expand, and thus keep the plate E approximately midway between the outer plates. The capacity variation is obtained by adjusting the distance between the two outer plates and the inner insulated plate.

Loud Speaking Telephones.

According to an invention* recently described, modulated currents are led to the plates of a condenser composed of metal foil sheets interleaved with sheets of flexible dielectric material, and the consequent

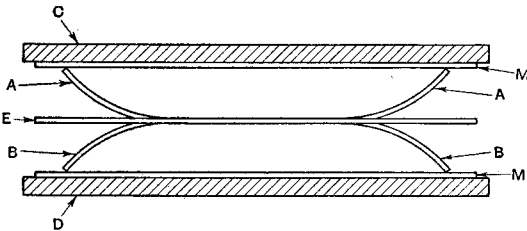
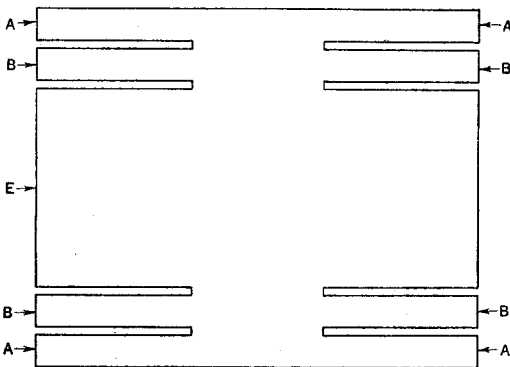

Fig. 2.

insulating material M, which prevents electrical contact being made with the outer plates. When the outer plates C and D, are moved towards or away from one another, the fingers are compressed or permitted

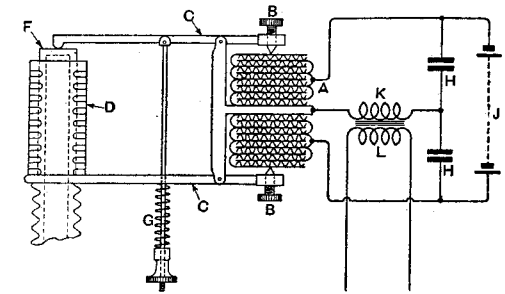

Fig. 3.

movement of the plates controls the flow of compressed air. A nozzle may be arranged opposite and close to the middle of one of the outer sheets of the condenser, which is enclosed in a casing provided with means for regulating the air pressure in it. Thus the movements of the sheet vary the effective aperture of the nozzle.

Referring to Fig. 3, A is a condenser formed of a number of metal grid sheets interleaved with sheets of flexible dielectric material. The top and bottom sheets bear against adjusting screws B, carried by levers C, C. Within the cylinder D, which is supplied with compressed air, works a piston F, which bears against the lever C.

The variations of current in the secondary K cause movements of the condenser plates A, and consequently movements of the piston F, so that the amount of the apertures uncovered by the piston will vary in accordance with the variations of the current. Therefore the air issuing from the apertures will produce sound waves.

W. J.

* British Patent No. 208,598, by F. K. Crowther and Radio Communication Company, Ltd.

* British Patent No. 208,806, by R. H. White.

RELAY FOR REMOTE CONTROL

A USEFUL DEVICE FOR FILAMENT SWITCHING AT A DISTANCE.

By J. F. PAYNE.

IT was desired to be able to switch on and off a valve receiving set installed in a shed at some distance from the house where the actual "listening in" took place. As there are, no doubt, many radio enthusiasts faced with the same problem, the writer's solution may prove of interest.

The only switching necessary was that of the filament current, and it was, of course, impracticable to carry filament circuit leads from the accumulators to the house. The obvious alternative was the use of a relay.

it is retained in place by the action of the permanent magnet.

The relay is operated by two push buttons ; one is pressed to switch on and the other to switch off. The control box containing these two buttons is seen to the right in the photograph. The box also contains jacks into which telephones or a loud speaker can be plugged. Of course, this system necessitates five wires (three for the relay and two for the telephones) being run from the receiver to the house, but as they need only be bell wire they can be run very incon-

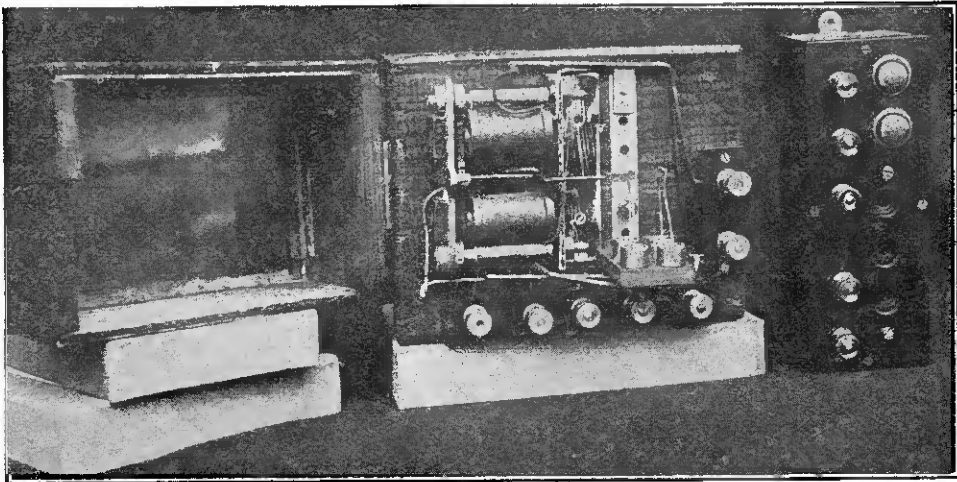

The relay is constructed from the action of a polarised bell, the armature causing wires to dip into mercury filled cups. The push buttons pull the contacts on and off, whilst the three holes are jacks for telephones or loud speakers.

The relay was constructed from the movement of a telephone bell. These bells are designed for ringing by alternating current and by suitable use of the two actuating coils it was found that the line (or operating) current need only be used to move the armature, and could then be switched off. The armature stops in contact with the pole to which it was last attracted, due to the fact that both it and the cores of the bobbins are polarised by a permanent magnet. In other words, after the armature has been moved

spicuously. In the writer's case two accumulators are controlled (one for the detector valve and the other for the L.F. amplifier), but in most instances one will be used, thus necessitating only one set of contacts on the relay and simplifying its construction. For instance, the wire connector may be attached directly to the "tongue" without the use of the piece of ebonite fitted by the writer.

The contacts are made from ordinary crystal cups containing mercury bridged by

pieces of copper wire attached to the "tongue" of the relay. A flash lamp battery is quite sufficient for furnishing the line current, or the accumulator which is controlled may be used for this purpose.

A diagram of the connections of the relay is given, and it is thought that by reference to this the action of the device will be more readily understood.

The bell movements in question can be obtained very cheaply from surplus Government stock. It should be noted that it may be necessary to adjust the distance of the armature from the poles in order to make use of the retention of the armature in position.

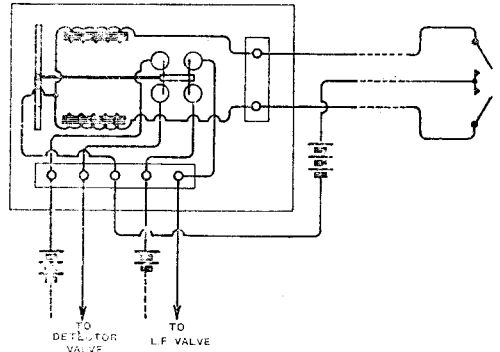

The circuit arrangement.

The Radio Society of Great Britain.

TRANSMITTER AND RELAY SECTION

The Franco-British Tests on 200 Metres.

After the inevitable delay in collating particulars from all parts of France, we are now able to publish an interesting report on the French reception of the British amateur transmissions during November and December last.

The undermentioned British stations were heard by French amateurs receiving in the places given:—

2 CW Alger, Arcachon, Calais, Moulins, Orleans, Paris, Reims.	5 WK Boulogne.	5 WR Arcachon, Boisguillaume, Calais, Orleans, Paris, Reims.	5 WR Arcachon, Boisguillaume, Boulogne, Le Bourget, Moulins, Orleans, Paris, Reims.
2 DR Alger, Arcachon, Audincourt, Calais, Moulins, Orleans, Paris, Reims, Thibie.	5 YI Calais.		6 EA Orleans, Reims.
2 KT Orleans.			
2 MG Calais, Reims.			
2 MJ Paris.			
2 NM Boisguillaume, Paris.			
2 OD Calais, Le Bourget, Orleans, Paris, Reims.			
2 OG Arcachon, Calais, Moulins, Orleans, Paris, Reims.			
2 RS Boulogne, Calais, Orleans, Reims.			
2 TF Reims			
2 WJ Calais, Le Bourget, Orleans, Reims, Thibie.			
2 YD Orleans.			
2 YG Thibie.			
2 YQ Arcachon, Calais, Paris, Reims.			
2 ZG Arcachon, Calais, Moulins, Orleans, Paris, Reims, Thibie.			
5 AA Le Bourget.			
5 BV Calais, Orleans, Paris, Reims.			
5 CO Le Bourget.			
5 DB Calais, Orleans, Reims.			
5 DM Calais, Reims.			
5 DN Arcachon, Boisguillaume, Boulogne, Calais, Le Bourget, Moulins, Orleans, Paris, Reims, Thibie.			
5 DO Moulins.			
5 FD Calais, Reims.			
5 GJ Reims.			
5 GO Orleans.			
5 HA Boulogne, Le Bourget, Paris, Reims.			
5 IP Arcachon.			
5 JX Reims.			
5 KC Moulins.			
5 KO Calais, Orleans, Paris, Reims, Thibie.			
5 NN Alger, Audincourt, Boulogne, Calais, Moulins, Orleans, Paris, Reims, Thibie.			
5 SI Calais, Orleans, Paris, Reims.			
5 SZ Arcachon, Boisguillaume, Calais, Moulins, Orleans, Paris, Reims, Thibie.			
5 UN Boisguillaume.			
5 WJ Boisguillaume.			
2 CW Moulins, Reims.			
2 DF Reims.			
2 DR Moulins, Orleans, Paris, Reims, Thibie.			
2 IF Boisguillaume.			
2 IN Moulins, Orleans, Paris, Reims.			
2 IW Parc Saint-Maur.			
2 JO Orleans, Reims, Thibie.			
2 KF Alger.			
2 KO Arcachon, Thibie.			
2 KW Orleans, Reims.			
2 MG Orleans, Parc Saint-Maur, Paris, Reims, Thibie.			
2 OD Moulins.			
2 ON Paris.			
2 RS Boulogne, Orleans.			
2 VO Paris, Orleans.			
2 VS Arcachon, Boulogne, Moulins, Orleans, Reims.			
2 WJ Orleans.			
2 YO Thibie.			
2 YQ Arcachon, Boulogne, Orleans, Reims.			
2 ZG Moulins, Reims.			
5 AL Paris.			
5 AR Moulins.			
5 BU Le Bourget.			
5 BV Orleans, Reims, Thibie.			
5 DM Reims.			
5 DN Boulogne, Le Bourget, Moulins, Parc Saint-Maur, Paris, Reims, Thibie.			
5 DO Parc Saint-Maur.			
5 HA Reims.			
5 JX Orleans, Paris, Reims.			
5 KO Alger, Le Bourget, Moulins, Orleans, Paris, Reims.			
5 OV Le Bourget.			
5 PR Paris.			
5 SZ Boisguillaume, Boulogne, Moulins, Orleans, Parc Saint-Maur, Reims, Thibie.			
5 US Orleans, Paris, Reims.			
5 VS Parc Saint-Maur.			
			2 IN Lyon, Orleans, Reims.
			2 JF Reims.
			2 JO Reims.
			2 MG Orleans, Parc Saint-Maur, Reims.
			2 NM Lyon, Orleans, Paris, Reims.
			2 NT Le Bourget.
			2 OD Alger, Le Bourget, Lyon, Paris.
			2 OG Lyon, Orleans, Reims.
			2 TA Orleans.
			2 TF Orleans, Parc Saint-Maur, Reims.
			2 VS Orleans, Reims.
			2 WF Boisguillaume.
			2 WJ Orleans, Parc Saint-Maur, Paris.
			5 AG Parc Saint-Maur.
			5 AT Paris.
			5 DN Lyon, Orleans, Paris, Reims.
			5 DU Paris.
			5 DO Parc Saint-Maur.
			5 DW Parc Saint-Maur.
			5 GL Orleans, Parc Saint-Maur, Reims.
			5 JX Orleans, Parc Saint-Maur, Reims.
			5 KO Orleans, Paris.
			5 MO Boisguillaume, Lyon, Orleans, Parc Saint-Maur, Paris, Reims.
			5 MU Paris.
			5 QV Reims.
			5 SG Paris.
			5 SI Reims.
			5 SZ Lyon, Orleans, Parc Saint-Maur, Paris, Reims.
			5 YI Orleans, Parc Saint-Maur, Paris, Reims.

(To be continued).

Location of Little-known Towns mentioned in the List.

Audincourt—In the department of Doubs.
Thibie—Near Chalons-sur-Marne, Department of Marne.
Boisguillaume—Near Rouen (Seine-Inférieure).
Le Bourget, Le Parc Saint-Maur, Thiais—Near Paris.
Arcachon—(Gironde).

LONG-DISTANCE TRANSMISSIONS.

A REPORT OF THE MORE RECENT AMATEUR ACHIEVEMENTS.

TRANSATLANTIC experimental working between amateur stations of the United States, Canada and Great Britain continues, with further successes each week, and although January did not prove an ideal month for such work, new records were set up.

or two British stations have been received at loud speaker strength on two valves; on one occasion the signals were audible 30 ft. from the telephones. These results are very encouraging, and, judging from the recent successes obtained by amateurs all over the world, the day is not very far distant when



Station 2 NM at Caterham and operated by Mr. Gerald Marcuse. It is one of the successful transatlantic stations, and is reported to have been heard in Algiers, Palestine and Egypt.

U.S.A. station **9 AZX**, Marion, Indiana, has been in touch with British **2 KF**, **2 OD**, **2 SH**, and this is a record for distance, being something over 4,000 miles from London. French **8 AB** has been logged by several stations in Washington and Oregon, on the Pacific Coast, but has not succeeded in conducting two-way working with them to date.

There is no doubt that reception of the shorter wave signals is showing great improvement both here and in America, this being confirmed by a letter from **U1 XW** (ex **1 MO**), who states that signals from one

stations in Australia and England will be in touch.

Already signals from at least two Australian stations have been heard by amateurs in southern U.S.A., these signals being on wavelengths of 200 metres and above, while many stations in the American Sixth District (California) are regularly heard by enthusiasts in Australia and New Zealand with comparative ease on two valve receivers.

The latest American success reported is the direct working across the Pacific Ocean, between **U 7 HG**, Tacoma, Washington, and **JPJU**, Tokio, Japan. A message sent by

the latter was copied and acknowledged by **7 HG**, although interference by atmospherics was very bad at the time. The power employed by the U.S.A. station was 700 watts, and the distance 4,600 miles entirely over water.

This achievement, however, is totally eclipsed by recent tests between stations **2 BM** at Sydney, Australia, and **4 AA**, New Zealand, when the former covered the intervening 1,500 miles with the ridiculous input of 0.5 of a watt. This sounds absurd, but nevertheless is an established fact, and actually happened. Again, the distance is entirely over water, which may explain the remarkable result to a great extent. Of

in touch with four or five British stations, and also worked with **PCII** and French **8 CT**. **1 DBI** was also successful in receiving telephony from **G 2 KF**, and was able to understand perfectly several remarks made by the British station, whose speech and C.W. was reported as being clear and good.

Further experiments are being made in this direction, and both stations are confident of future successes with telephony. The American stated that he was using a roughly-made receiver which was certainly not designed for reception of speech, and he termed it a "cracker box" receiver. Several stations in England are to be heard in regular communication with U.S.A., and every day

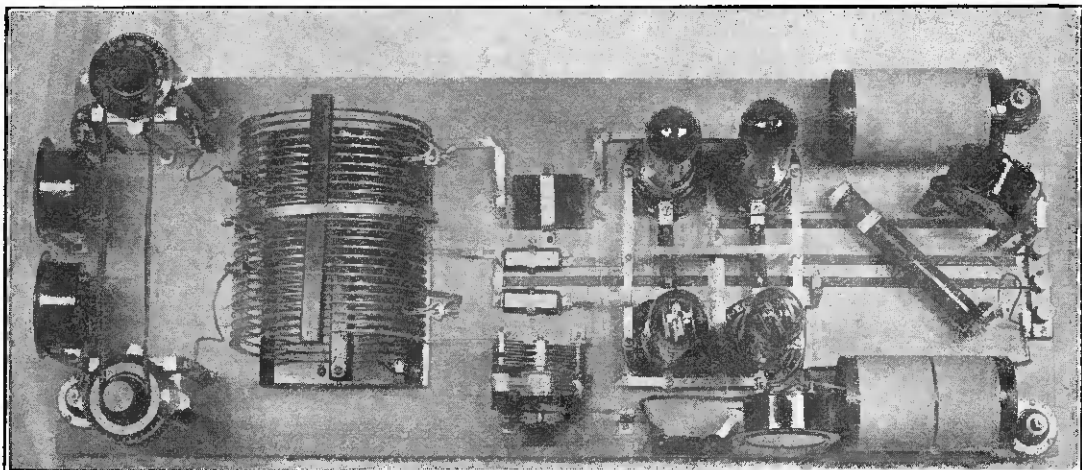

*The transmitting equipment at **1 MO** (also known as **1 XM**). The station is operated by Mr. K. B. Warner, Editor of "Q.S.T." and Secretary of the American Radio Relay League. It was the first American station to establish working with European amateurs.*

course, regular working between amateur stations only a mile or so away would not be reliable using such power, but it appears that these two stations are able to communicate in almost any weather conditions, using only a very few watts of power.

Sunday morning, February 10th, proved to be ideal as regards weather conditions, but so many stations were working that the jamming on both sides of the Atlantic was very bad. American, French, Dutch and British amateur stations were all in communication at various times between midnight and 7 a.m., and some very useful work was carried out. American **1 BDI**, Orono, Maine, who is now one of the most powerful of the stations working with Europe, was

others are added to the list, which now includes **5 KO** and **2 KW**.

G 2 OD and Canadian **1 BQ** for many mornings worked to schedule, and there were only two or three occasions on which two-way working was impossible. **1 BQ** is by far the most consistent of the Canadians, who now include **2 BN**, **1 DD**, **1 BQ** and **3 BP**.

In Europe much useful work is taking place, and **7 QF**, of Copenhagen, although still weak, has effected, on two occasions, two-way working with **G 2 KF**.

Italian **ACD**, Bologna, on the Adriatic Coast, has succeeded in working with U.S.A. without any pre-arranged schedule. The signals are received very strongly in London. This station has also worked with **2 KF** and

2 NM, and has received telephony from both these stations. He also reports telegraphy from **2 AW**, **2 BN**, **2 FQ**, **2 FN**, **2 OD**, **2 PC**, **2 WJ**, **5 AT**, **5 BN**, **5 BV**, **5 BY**, **5 NN**, **5 QN**, **5 WR**, **6 XX**, **6 YA**. His receiver consists of two valves arranged as detector and note magnifier, which seems to be the most popular combination for short wave distance working. The address of this station is Adriano Ducati, 3 via Garibaldi, Bologna, and he is anxious to receive reports from British amateurs.

WNP, the *Bowdoin*, the ship of the McMillan Arctic Expedition, is yet to be heard by British amateurs, and from reports received through **1 XW**, his signals are very weak at the present time, even to the Northern Canadian amateurs. The wavelength of the *Bowdoin* is still around 200 metres, which is unfortunate, for were he to drop to the 150 metre region his chances of reaching us might be greater.

Recent observations taken during these very short wave experiments show that not only do the signals travel well over both land and water, but there is a marked absence of "swinging," and the incoming signal maintains almost the same strength throughout a whole transmission. It also appears that when the barometer commences

Another feature is the sharpness of tuning and ease with which the receiving station

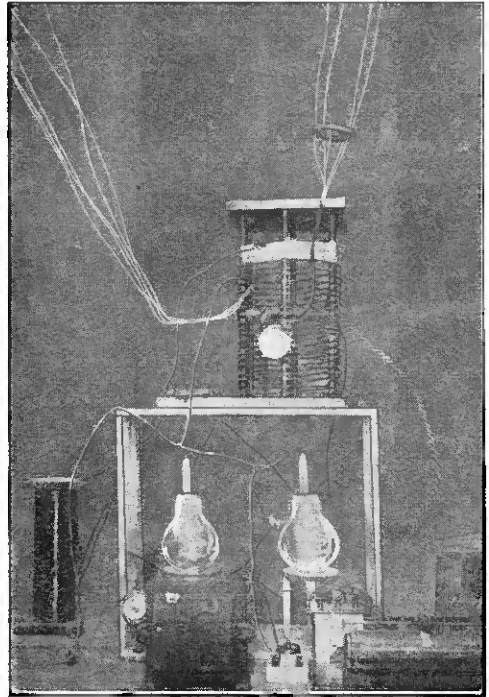

Transmitter 2 SZ at the Mill Hill School, which works with several American and Canadian stations. The installation is by Mr. C. W. Goyder. This is the first transatlantic success of the Schools Radio Society, which is a section of the Radio Society of Great Britain.

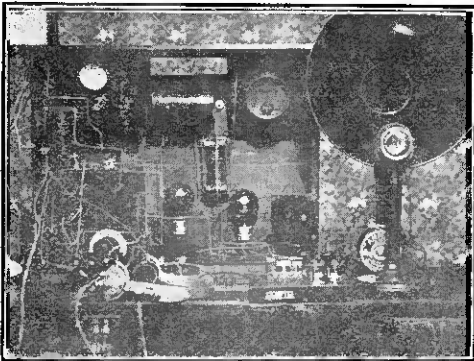

Apparatus at 5 TR (Ilford) used for C.W. and telephony working with Belfast. Power as low as 2½ watts has been successfully used for communicating over the distance.

to fall, the strength of the American signals increases, and the same thing applies on the other side.

can tune out interference, and read the desired signal. A metre or two either way, and the incoming signal, if the transmitting station is properly tuned, will be lost entirely. This, of course, does not apply in the case of loud speech from a local station which covers a much larger range, but even then the interference is not nearly so bad as on the 180 to 200 metre band.

It also appears that it is far better to work on a wavelength below the fundamental of the aerial with the aid of series condensers than to reach the shorter waves by shortening the aerial itself, but this theory is yet to be proved.

J. A. P.

THE AMATEUR'S PARLIAMENT

A TALK BROADCAST FROM 2 LO ON BEHALF OF THE
RADIO SOCIETY OF GT. BRITAIN ON FEB. 14th.

By F. HOPE-JONES, M.I.E.E.

Vice-President of the Radio Society of Great Britain.

THE Fifth Annual Conference (postponed from last month owing to the railway strike) is to be held on the afternoon of Saturday, March 1st, at the Institution of Electrical Engineers.

This is the wireless amateur's only parliament—the one opportunity you get each year of letting your voice be heard concerning the practice of your hobby and the maintenance of freedom and facilities for experimental work.

Everyone of the wireless societies affiliated to the Radio Society of Great Britain—and there are over 200 of them—representing the wireless amateurs of the whole country, has now received its writ and is proceeding to the election of the delegates. Let every amateur experimenter see to it that his constituency is well represented. Make it your business to ascertain who is being elected by your local Society, and what instructions have been given him with regard to the important matters on the agenda, which has already been published in *The Wireless World and Radio Review* of January 30th. If you are not satisfied that you are being properly represented, write to the Secretary of the R.S.G.B., 53, Victoria Street, London, S.W., and ask for an invitation to attend yourself.

The agenda this year is concerned mainly with the establishment of your own organisation, that is to say, the machinery whereby the voice of the amateur shall be heard by the authorities who rule the ether. In previous years the Conference has spoken for the amateurs of the country with no uncertain voice, but with the force born of unanimity, and has thereby secured for you the concessions which you now enjoy. It was the bold demand of the 1920 and 1921 Conferences for permission to transmit music that paved the way for broadcasting, and the amateurs of the country are entitled to enjoy the special satisfaction earned by an unselfish act, for they have created a national pastime which has seriously curtailed their own facilities for experiment.

These conferences were called by the parent society. You are now invited to adopt them as your own and for that purpose to create a general committee elected by the affiliated societies, whose collective interests will be their special care.

Every society sends a delegate to the conference, but every society cannot elect a representative on the general committee—the number would make it unwieldy. The societies have therefore been

asked to divide themselves into groups, and each group will elect a member of the committee. It is suggested that such groups shall consist of not less than six societies, but I imagine this rule will be flexible, and that the numbers in each will differ according to local conditions and the varying influences which tend either to throw societies together or to keep them apart in healthy and friendly rivalry.

But I want to impress upon the secretaries of all affiliated societies the necessity of taking up this question of grouping immediately. Don't be shy of taking the initiative. Write to the secretaries of the other societies within easy reach. Between you, you will be able to suggest some wireless amateur of outstanding ability or reputation as a man of affairs who, though resident in your district and *persona grata* with the local societies, is accustomed to travel and has business calls to London.

In a word, do your share towards the election of a strong general committee at the Conference. We shall be disappointed if there are not at least 20 groups, and 20 representatives of them.

Do not confuse this general committee with the Council of the Radio Society of Great Britain. The general committee's principal work is to assist the affiliated societies, by whom its members are mainly elected. Believe me, there are many good things in preparation which individual societies could not provide for themselves, but which can be done by co-operation, and will be done by this committee. But with regard to national affairs the duties of the general committee will be advisory. They will say what the country wants and the Council will get it—or try to. Communications with the Government or other public bodies is reserved to the Council for very good reasons, which will be obvious to anyone who knows the value of collective bargaining and of continuity of policy.

Don't forget that it is the effort of each individual blade of grass that makes a green field. You are doubtless proud of our fellow members who have carried on conversations with the United States of America, but could they have done it without experiments, and could they have carried out those experiments if you had not, by your support of the national amateur organisation, wrung from an apathetic and unwilling Government department that modest measure of freedom which we now enjoy?

CORRESPONDENCE.

The Armstrong Super.

To the Editor of THE WIRELESS WORLD AND RADIO REVIEW.

SIR,—With reference to the exceedingly lucid explanation of the functioning of the Armstrong Circuit given by Mr. D. F. Stedman in a recent issue of the *Wireless World and Radio Review* (November 26th), may I be permitted to add a few words from my own experience of the circuit?

I do not quite agree with the author's statement that "rectification by a potentiometer promptly makes it very critical, causing the valve to oscillate on one frequency only (either H.F. or Armstrong) and howl very easily."

I presume he means that the grid condenser and leak are here shorted. In my experience, stability even exceeding grid condenser rectification may be obtained, but the Armstrong coil coupling and filament control are very critical—particularly the filament control. I find that by using the normal circuit and normal H.T. volts, by short-circuiting the grid condenser, loosening Armstrong coupling, and reducing filament current very carefully, a point is reached where telephony is heard in the "Infra Armstrong" region. Stability is very marked. Signals not quite so strong as normal circuit. Tightening H.F. reaction coupling to the "Armstrong region" results in very weak heterodyne and a peculiar "deadness" in the circuit.

I once got extraordinary results by above adjustments, but in this case the filament had to be very bright—almost the full six volts across it. H.T. about 90 v. Signal strength on 2-ft. frame equal to good three valves on outdoor aerial. It was a little difficult to find the right filament temperature and Armstrong coupling, and the circuit was not very stable, the least thing causing it to oscillate at H.F. frequency only.

I do not agree with the author that potentiometer rectification makes the set howl easily. I have yet to hear a howl from my set under these conditions.

The author did not mention spark reception. I find that for 600 m. spark (where the normal grid condenser circuit is not very efficient) far better results on weak signals are obtained by the shorted-grid-condenser circuit and critical filament control. On the shorter waves, however, the normal circuit is much better.

Hoping this has not encroached too much on your valuable space.

J. G. W. THOMPSON.

Edinburgh.

A.C. on Amateur Transmitting Valves.

To the Editor of THE WIRELESS WORLD AND RADIO REVIEW.

SIR,—During the past eight or nine months it has been observed that the number of foreign amateur transmitting stations on the 150-200 metre waveband has increased enormously. The use, however, of A.C. supply on the anodes of

their transmitting tubes has made ordinary low power working well nigh impossible with distant stations, particularly after 2300 G.M.T. I have had the whole range of my tuning condensers choked up with these appalling indications that the Continental radio world is on the war path. I know several users of unrectified A.C. will counter with the question of selective receivers. It is not for me to expound on the selective powers of my receivers, but I have quite satisfied myself on that point. As most of us know, nothing but flat tuning can result from applying A.C. mains to oscillator tubes without elaborate precautions—and considering the present congested state of the short wave ether, I think it is up to everyone to tune their transmissions as sharply as possible. For those who don't know, a rectifier and filter circuit will work wonders.

Whether it is the belief that unrectified A.C. will carry further, or not, the habit is becoming dangerously infectious in our island, but it is my experience that pure C.W. has it every time. In view of the relatively high powers allotted to Continental amateurs, I think it is up to them to cause minimum Q.R.M. by seeing that their wave is sharply defined. I would welcome the views of others on this subject.

W. G. BAGULEY,
(5 GL).

Newark-on-Trent.

A Word for the Code Man.

To the Editor of THE WIRELESS WORLD AND RADIO REVIEW.

SIR,—The extension of broadcasting hours no doubt troubles those amateurs who are interested in telephony transmission, and who make use of the 440 metre wave. Accordingly amateur broadcasters are swooping down on to 200 metres.

There seems to be two conflicting kinds of amateur transmitters, viz., those who work in code and try to get the maximum distance with the power allowed, trying every kind of circuit they can think of, and those who work a 'phone station and endeavour to perfect the present systems of modulation.

At present, about three dozen enthusiastic code men can be heard night after night working with one another and having friendly conversations with their French and Dutch neighbours. The effect of a few local phone stations would be rather disastrous, particularly as some of the last mentioned seem to think nothing of putting on four or five antiquated gramophone records without ever switching off and listening in.

What transmitters must realise is that they must co-operate. Whether the experimenter be interested in telegraphy or telephony, the only way in which he can have a voice in protecting his rights is to join such a body as the British Wireless Relay League, which seems to be a step in the right direction.

EX. PERI-MENTER.

Lancashire.

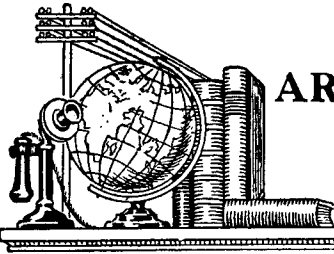

AROUND THE WIRELESS WORLD

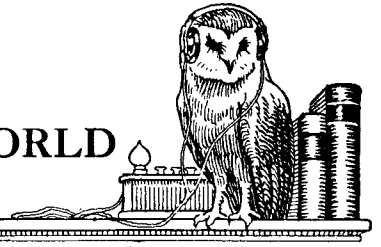

The announcement that the Postmaster-General of the Irish Free State is prepared to grant listening-in licences has resulted in a wireless boom throughout the country.

* * *

The B.B.C. has decided to broadcast special programmes for the benefit of visitors to the British Empire Exhibition at Wembley.

* * *

When a recent blizzard isolated Chicago, Minneapolis, Milwaukee and Kansas City, wireless formed the sole means of communication with the storm-bound towns.

* * *

A wireless exhibition is to be held at Geneva from May 21st to June 1st. The principal object of the exhibition will be the popularisation of broadcasting.

* * *

Another Swiss Broadcasting Station.

A broadcasting station is to be installed at Hoengg, near Zurich, according to our French contemporary, *La T. S. F. Moderne*. The new station will employ a power of 500 watts and transmit on 300 and 600 metres.

Convicts Forbidden Wireless Concerts.

A convict named Jacob Bernstein, with a number of fellow-prisoners, is deploring the inconsiderate action of the officials in the county gaol at Lebanon, Pennsylvania. When, last December, Bernstein was imprisoned for "bootlegging," a wireless set was at once installed in his cell, equipped with an amplifier which permitted concerts to be heard throughout the institution. The angry townspeople have now protested, with the result that Bernstein and his companions are denied the simple delights of broadcasting.

British-Italian Two-Way Working.

Two-way communication with ACD (Bologna, Italy), has been successfully established by Mr. Hugh N. Ryan (5 BV), of Wimbledon Park. 5 BV employed a power of 20 watts.

Venice Dances to Savoy Hotel Band.

On the night of January 22nd, states Mr. Giulio Salom (1 MT), of Venice, several ladies and gentlemen at his station indulged in a fox-trot, shimmy and one-step to the strains of the Savoy Hotel Dance Band broadcast from 2 LO. A four-valve "Siti-Doglio" set was used, with a Brown loud-speaker, and the music could be plainly heard 50 feet from the instrument.

Amateur Transmissions from Luxembourg.

The transmission from Luxembourg referred to in our columns last week probably emanated from the station of the Radio Club of Luxembourg, which transmits frequently at about 8 p.m., on a wavelength slightly over 200 metres.

Reports of the reception of Luxembourg (1 JW) have now reached us from a number of readers, some of whom have heard the station clearly on a loud speaker.

Regular Broadcasting from U.S.

The British Broadcasting Company expect that during the next two months it will be possible to re-transmit American broadcast programmes regularly. Some doubt, naturally exists as to whether this feature can be maintained during the summer months when atmospheric conditions are so prevalent, but the possibility is not excluded by the Company's engineers.

The Finnish Amateur.

Wireless amateurs in Finland are allowed considerably more latitude than their English cousins, according to information we have received from Mr. Erkki Heino (2 NB) of Suomi, Finland. The first legal recognition of amateurs took place in August, 1921, and facilities for experimenting have increased so much since then that receiving is now permitted without any licence fee. The wavelength allotted to amateur transmitters is 300 metres and a power of 20 watts is allowed for C.W. transmission. Spark transmitters may use 100 watts.

The whole amateur organisation in the country is under the control of a society known as the Suomen Radioamatööriyhdistys, the secretary of which is Mr. Erkki Linkisala, of Helsinki, Pietarinkatu 5, Suomi, Finland.

That Puzzling Transmission.

Our note on the fine French concert received by a correspondent on Sunday, January 13th, between 5 and 6 p.m., has evoked a number of letters from others who heard the transmission. From the character of these reports it is evident the "mysterious" transmitter was Brussels, BAV, which broadcasts regularly on 410 metres at the time mentioned.

Another Ether Poacher.

The call sign 5 SW is being used by two transmitters. The legitimate owner, Mr. C. Bedford,

of Gildersome, Nr. Leeds, states that he is continually receiving letters from listeners who have heard his call sign on occasions when his station has been silent. These reports chiefly come from the North.

German Broadcasting Developments.

A Berlin reader informs us that, in addition to those at Koenigswusterhausen and Berlin (Vox Haus), broadcasting stations are to be erected at Muenchen, Frankfurt, Stuttgart, Breslau, Leipzig, Koenigsburg and Hamburg.

Difficulties in obtaining experimental licences in Germany have greatly restricted the activities of wireless amateurs in the past, but now that broadcasting developments are proceeding apace, the number of private wireless sets is steadily increasing. A new kind of licence has been introduced, costing 60 marks per annum, which entitles the owner to buy a sealed receiver covering a wavelength range of from 250 to 700 metres.

By arrangement with the Post Office, the Radio clubs are permitted to issue experimental licences to those members who can demonstrate their proficiency. In addition, every radio club may erect one transmitting station.

Lunch Hour Transmissions from 2 LO,

Commencing on Monday, February 25th, the London broadcasting station will transmit a programme between 1 and 2 p.m., three times weekly. It is hoped that the requirements of night-workers will thus be met, and that the new development will assist wireless dealers.

American Broadcasting Feat.

It is computed that between forty and fifty million people heard General John Carty, of the Bell Telephone Company when he spoke before the microphone at the Congress Hotel, Chicago, on Friday, February 8th. This immense audience was obtained by linking up seven leading broadcasting stations, including those at Havana (Cuba), New York and San Francisco. It is estimated that over 5,000 miles of telephone were used, in addition to a hundred miles of submarine cable connecting Key West, Florida, with Cuba.

A Self-Contained Receiver.

The advent of the dull emitter valve, dispensing with the bulky and heavy accumulator, has brought with it the self-contained radio receiver. One of the first firms to produce such a set is Messrs. McMichael, Ltd., whose new instrument designed on these lines is entirely contained in a handsome oak cabinet, while embodying the circuit embodied in the well-known M.H.B.R.4. receiver.

A Five-Valve Gecophone.

A newcomer among the more elaborate broadcast receivers is the Gecophone Five-Valve Cabinet Receiving set, embodying 1 H.F., Detector and 3 L.F. valves. The wave range covers all the B.B.C. stations and extra coils can be obtained to cover experimental stations. It is interesting to note that the L.F. valves are resistance capacity coupled. The instrument is supplied in a handsome mahogany cabinet and incorporates a small 120-volt H.T. battery.

SAMPLES RECEIVED, ETC.

N. Heywood (386, Richmond Road, Twickenham, Middlesex). Three new types of crystals, viz., Galenel, Spinel and Dornel. Also sample of Wood's Alloy, and a pair of headphone pads.

Leslie G. Russell (5, Hill Street, Birmingham). A specimen of Mexican Gneiss Crystal, retailed from the above address as 1s. 9d.

Multiphone Terminal Co. (21, Great Russell St., London, W.C.1.). The following retail price reductions in Multiphone Connectors (see *The Wireless World and Radio Review* of January) have now taken effect:—4-way Round reduced from 1s. to 9d. retail; 4-way Long reduced from 1s. to 9d. retail; 6-way Round reduced from 1s. 6d. to 1s. retail. Wholesale prices are proportionately affected.

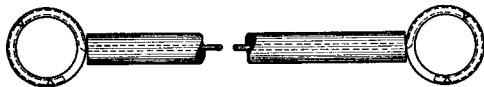

(Courtesy: Loveland Bros. & Sons).

A new type of connector known as the "Jiffy Link." It is supplied in lengths from 1/2" to 24" with a wide range of gauges and eyelet sizes.

Forthcoming Events.

WEDNESDAY, FEBRUARY 20th.

- Edinburgh and District Radio Society.** At 8 p.m. At 117, George Street. Lecture: "Oscillographs." By Mr. C. N. Kemp, B.Sc.
- Golders Green Radio Society.** At 8 p.m. At the Club House, Willifield Green, N.W.11. Lecture: "Fine Wire Coils as an aid to Definition." By Mr. J. H. Reeves, M.B.E.
- North Middlesex Wireless Club.** At Shaftesbury Hall, Bowes Park, N. "Some Types of Broadcast Receivers."
- Hampton and District Radio Society.** Lecture: "Long Distance Telegraphy." By Dr. Rayner.
- Clapham Park Wireless and Scientific Society.** Lecture: "Short Wave Reception." Mr. S. Abbot.

THURSDAY, FEBRUARY 21st.

- Hackney and District Radio Society.** Two Cinematograph Films, "The Audion" and "Telephone Inventors of To-day."
- Hornsey and District Wireless Society.** At Queen's Hotel, Broadway, Crouch End, N.8. Informal Meeting of Advanced Members. Subject, "Practical Demonstration with the Neutrodyne Receiver."
- Dewsbury and District Wireless Society.** Experimental evening.
- Sale and District Radio Society.** At 37, School Road, Sale. Lecture by Mr. W. R. Burne.

FRIDAY, FEBRUARY 22nd.

- Brockley and District Radio Association.** At Gladstone Hall; New Cross Road. Lecture: "General Finish to Panels." By Mr. J. E. Griggs.
- Sheffield and District Wireless Society.** At 7.30 p.m. At the Dept. of Applied Science, St. George's Square, Elementary Class.
- Wireless Society of Hull and District.** At 7.30 p.m. At Co-operative Social Institute, Jarratt Street. Discussion on the admission of constructors and broadcast listeners to the Society.
- Bristol and District Radio Society.** Address by Prof. W. A. Andrews: "A Random Talk on Wireless."

MONDAY, FEBRUARY 25th.

- Ipswich and District Radio Society.** At 55, Fonnereau Road. Open Night.
- Dulwich and District Wireless and Experimental Association.** Lecture: "Telephony Transmission." By Mr. George Sutton, A.M.I.E.E.

TUESDAY, FEBRUARY 26th.

- Huddersfield and District Radio Society.** At 7.30 p.m. At the Y.M.C.A., John William Street. Lecture: "The Practical Design of Wireless Receivers for Broadcast Reception." By Mr. P. Harris.

WEDNESDAY, FEBRUARY 27th.

- Radio Society of Great Britain.** At 6 p.m. (tea at 5.30). At the Institution of Electrical Engineers. "A Practical Demonstration of the Applications of the Cathode Ray Oscillograph." By Mr. N. V. Kipping.

Calls Heard.

Brixton Hill, S.W.2.

2 AU, 2 GO, 2 JR, 2 NP, 2 OK, 2 RN, 2 SD, 2 SO*, 2 VS, 2 VY, 2 XO, 2 YR, 5 AA, 5 AS, 5 BV, 5 CP, 5 DM*, 5 DN, 5 HS, 5 OB, 5 PD, 5 PR, 5 PU, 5 RB, 5 SL, 5 TV, 6 CG, 6 RD, 6 SH, 8 AB, 9 CO, 0 CMX, 3 NR, 3 ABQ. (Single valve.) *Flewelling.
(R. E. Broomfield.)

Clacton-on-Sea.

2 AO, 2 AP, 2 AV, 2 CO, 2 DF, 2 FL, 2 FP, 2 FQ, 2 GN, 2 GZ, 2 HF, 2 IL, 2 JF, 2 KF, 2 KT, 2 LG, 2 LZ, 2 MC, 2 MD, 2 NM, 2 OM, 2 ON, 2 OZ, 2 PF, 2 PK, 2 QN, 2 SA, 2 SL, 2 SM, 2 SO, 2 SZ, 2 TA, 2 TF, 2 TO, 2 VD, 2 YN, 2 YS, 5 AT, 5 BV, 5 CX, 5 DN, 5 DT, 5 DY, 5 GJ, 5 JX, 5 KO, 5 LC, 5 LP, 5 NN, 5 NQ, 5 PU, 5 PZ, 5 QM, 5 RZ, 5 TG, 5 WN, 5 WR, 6 BT, 6 HA, 8 AE, 8 AQ, 8 AR, 8 AW, 8 AZ, 8 BA, 8 BM, 8 BE, 8 CD, 8 CJ, 8 CS, 8 CT, 8 CZ, 8 DA, 8 DK, 8 DU, 8 LI, 8 LV, 0 AA, 0 AB, 0 BQ, 0 DV, 0 MX, 0 NY, 0 KP, 0 KW, 0 YS. (2-valve Reinartz.) (F. L. Stollery, 5 QV.)

Valenciennes, France (since October, 1922).

2 AF(?), 2 AJ(?), 2 AO*, 2 AW*, 2 CW*, 2 DF*, 2 DJ, 2 EN*, 2 FP, 2 FQ, 2 GG, 2 GN, 2 GV*, 2 GZ, 2 IJ*, 2 IN*, 2 JF*, 2 JJ(?), 2 JM, 2 JO*, 2 JP*, 2 JZ, 2 KF*, 2 KQ*, 2 KT, 2 KX*, 2 KW*, 2 LG, 2 LZ*, 2 MM*, 2 NA*, 2 NG, 2 NM*, 2 OD*, 2 OM*, 2 ON, 2 OP, 2 PX, 2 QH, 2 QN, 2 RB*, 2 SH, 2 SZ*, 2 TA*, 2 TB*, 2 TC*, 2 TP, 2 VF*, 2 VN, 2 VO*, 2 VS, 2 VT, 2 VW*, 2 WA, 2 WJ*, 2 WO, 2 XL, 2 YI, 2 YQ, 2 ZG, 2 ZK*, 2 ZL, 2 ZN, 5 BA, 5 BG, 5 BV*, 5 CX*, 5 DN, 5 FS, 5 GS, 5 HI, 5 IC, 5 ID*, 5 IO, 5 KO*, 5 LC, 5 MJ, 5 NH, 5 NN*, 5 OS*, 5 PU, 5 QM*, 5 RB, 5 RI*, 5 RQ*, 5 SH, 5 SI, 5 WR*, 5 ZV, 6 BV, 6 EA(?), 6 NI*, 6 OY, 6 RY(?), 6 XX, 8 AA*, 8 AB*, 8 AE*, 8 AF*, 8 AG, 8 AQ*, 8 AR, 8 AS*, 8 AW*, 8 AZ, 8 ARA*, 8 BA*, 8 BC, 8 BE, 8 BF*, 8 BL, 8 BN*, 8 BV*, 8 BX, 8 CC, 8 CD*, 8 CE*, 8 CH, 8 CI, 8 CK, 8 CM*, 8 CS*, 8 CT, 8 DA*, 8 DC, 8 DD*, 8 DE*, 8 DI, 8 DJ*, 8 JL, 8 LY, 8 LB, 8 RD, 8 RCD, 8 SZ, 8 AP, 0 AR*, 0 BQ*, 0 DV*, 0 FN, 0 NX*, 0 NY*, 0 MX*, 0 EZ*, 0 XL*, 0 XO*, 0 XP, 0 DW*, 0 YS, 0 ZN*, 0 PA, 0 MI, 0 AD, 1 ASE, 3 OL, 4 FL, 6 AB*, ZLS, 2 AW†, 2 KF†, 2 SH†, 5 KO*†, 1. M†, 8 AB†, 8 BF†. (1-det. and 1-det-2.)
* Stations worked. † On 100 metres. (Roger Dupont, 8 BM.)

Hellerup, Denmark.

ACD, 1 ER, 1 MT, 2 CN, 2 CW, 2 DF, 2 FN, 2 GW, 2 JP, 2 KQ, 2 LG, 2 LZ, 2 MG, 2 MM, 2 OJ, 2 ON, 2 PG, 2 SQ, 2 TB, 2 TE, 2 UV, 2 VE, 2 WA, 2 WJ, 2 XP, 2 ZG, 2 ZK, 2 ZS, 2 ZT, 2 ZU, 2 ZW, 2 ZX, 5 AT, 5 BA, 5 BG, 5 CS, 5 GS, 5 IC, 5 IE, 5 JX, 5 GS, 5 IC, 5 LE, 5 JX, 5 KZ, 5 MO, 5 NN, 5 OM, 5 PU, 5 QV, 5 RZ, 5 SI, 5 SZ, 6 EA, 6 GO, 6 NE, 6 RY, 6 UC, 6 XX, 8 AA, 8 AE, 8 AG, 8 AV, 8 AZ, 8 BA, 8 BE, 8 BF, 8 BN, 8 BV, 8 BW, 8 CF, 8 CH, 8 CJ, 8 CM, 8 CS, 8 CT, 8 CZ, 8 DU, 8 DV, 8 ER, 8 JI, 8 LY, 8 XX, 0 AB, 0 AC, 0 AR, 0 DV, 0 FN, 0 KX, 0 MR, 0 NY, 0 RZ, 0 SA, 0 VP, 0 XP, 0 XW, 0 YS, PA 9, PAR 14. (0—v—0.) (J. Steffensen.)

Louvain, Belgium.

2 AP, 2 FN, 5 AW, 5 MO, 8 BP, 8 BV, 8 CJ, 8 CN, 8 CS, 8 CZ, 8 DU, 8 EM, 8 TA, 1 MT, 1 JW, 0 AB, 0 NY, 0 SA, 0 XO. (A. Stainier.)

Yeovil, Somerset.

2 AS, 2 CV, 2 DM, 2 ES, 2 FL, 2 GG, 2 GV, 2 IL, 2 MP, 2 OM, 2 OY, 2 PL, 2 RH, 2 SE, 2 TN, 2 WU, 2 YW, 2 ZG, 5 CC, 5 DO, 5 KO, 5 MU, 5 PU and 6 TH. (1—v—2.) (L. W. C. Martin, 5 AB.)

Dollar, N.B.

1 MT (Venice), 2 AO, 2 CW, 2 DD, 2 DJ, 2 GN, 2 FN, 2 FQ, 2 HF, 2 IL, 2 IN, 2 JF, 2 KR, 2 KT, 2 KX, 2 LG, 2 LZ, 2 NM, 2 PJ, 2 PP, 2 QK, 2 RY, 2 SH, 2 SM, 2 SZ, 2 TB, 2 UV, 2 VN, 2 VQ, 2 VS, 2 WA, 2 WK, 2 WJ, 2 XX, 2 YQ, 2 ZG, 2 ZK, 2 ZU, 4 ZZ, 5 AT, 5 AW, 5 BA, 5 BG, 5 BV, 5 BZ, 5 CX, 5 DN, 5 FS, 5 HI, 5 IC, 5 IK, 5 KC, 5 KO, 5 LY, 5 MO, 5 MP, 5 MU, 5 OL, 5 OT, 5 PU, 5 QM, 5 QY, 5 RI, 5 SZ, 5 TK, 5 US, 5 VR, 5 WM, 5 WX, 5 WV, 5 XX, 5 YI, 5 ZY, 6 DW, 6 EA, 6 GY, 6 JX, 6 MB, 6 NH, 6 NI, 6 NS, 6 OW, 6 OX, 6 RW, 6 RY, 6 TM, 6 UC, 6 ZY, 7 EC, 7 ZM, 8 AB, 8 AG, 8 AS, 8 AQ, 8 AU, 8 AV, 8 AZ, 8 BA, 8 BE, 8 BF, 8 BV, 8 BW, 8 CJ, 8 CK, 8 CM, 8 CT, 8 CZ, 8 DQ, 8 DU, 8 DY, 8 EB, 8 EM, 8 EM, 8 JL, 8 RZ, 8 SZ, 0 AB, 0 GS, 0 KX, 0 MX, 0 MR, 0 XO, 0 XP, 0 ZZ. American 1 ARY, 2 BGG. (Ian F. Sime.)

2 WU?

Our recent request as to the identity of 2 WU has evoked a reply from Captain C. H. Bailey (2 WU), of Chepstow, who states that his call sign has probably been mistaken as 2 UU owing to the awkwardness of his call letters.

Captain Bailey wishes it to be known that he has relinquished his pre-war call sign BXH, which was allotted to his former station at Stelvio, Newport, Mon.

Broadcasting

REGULAR PROGRAMMES ARE BROADCAST FROM THE FOLLOWING EUROPEAN STATIONS:—

GREAT BRITAIN.

ABERDEEN 2 BD, 495 metres; BIRMINGHAM 5 TT, 475 metres; GLASGOW 5 SG, 420 metres; NEWCASTLE 2 NO, 400 metres; BOURNEMOUTH 8 BM, 385 metres; MANCHESTER 2 ZY, 375 metres; LONDON 2 LO, 365 metres; CARDIFF 5 WA, 355 metres; SHEFFIELD (Relay from 2 LO), 303 metres. Mondays, Wednesdays, and Fridays, 1 p.m. to 2 p.m. (2 LO only). Regular daily programmes, 3.30 to 4.30 p.m., 5 to 10.30 p.m. Sundays, 3 to 5 p.m., 8.30 to 10.30 p.m.

FRANCE.

PARIS (Eiffel Tower), FL, 2,600 metres. Daily, 6.40 to 7 a.m. Weather Forecasts; 10.50 a.m. (Thursday and Friday), 11.15 to 11.30 a.m., Time Signal and Weather Forecast; 12.0 noon, Live stock prices; 3.40 p.m. (Saturday excepted); Financial report, 5.30 p.m. (Saturday excepted) Bourse Closing Prices; 6.10 p.m., Concert or Address; 7 p.m., Weather Forecast; 7.20 p.m. (Sunday), Concert and Address; 10.10 p.m., General Weather Forecast.

PARIS (Compagnie Francaise de Radiophonie Emissions "Radiola"), SFR, 1,780 metres. Daily, 12.30 p.m., Cotton Oil and Café Prices, News, Concert; 1.45 p.m., First Bourse Report; 4.30 p.m. Bourse Closing Prices; 4.45 p.m., Concert; 5.45 p.m., News and Racing Results; 8.30 to 9 p.m., News; 9 p.m., Concert; 10 p.m. to 10.45 p.m., Radio Dance Music.

ECOLE SUPERIEURE des Postes et Télégraphes, 450 metres. 9 p.m. (Sunday, Wednesday, Thursday, Friday and Saturday), Talk on Literature, Dramatic and Musical Selections. 8.15 p.m. to 9.25 p.m. (Tuesday), Morse Practice, English Lesson, Lecture and Concert.

LYONS, YN, 3,100 metres. Daily, 9.45 a.m. to 10.15 a.m., Gramophone Records.

NICE, 460 metres. 11 a.m., 5 p.m. to 6 p.m., 9 p.m. to 10 p.m. Concert and News.

BELGIUM.

BRUSSELS, BAV, 1,100 metres. At 1 p.m. and 5.30 p.m., Meteorological Forecast; 9 p.m. (Tuesday), Concert.

BRUSSELS ("Radio Electrique"), 410 metres. Daily, 5 to 6 p.m., 8.30 p.m. to 9.30 p.m., Concert.

HOLLAND.

THE HAGUE, PCGG, 1,070 metres. 3 to 5 p.m. (Sunday), 8.40 to 10.40 p.m. (Monday and Thursday), Concerts.

THE HAGUE (Heussen Laboratory), PCUU, 1,050 metres. 9.40 to 10.40 a.m. (Sunday), Concert; 8.40 to 9.40 p.m., Concert; 7.45 to 10 p.m. (Thursday), Concert.

THE HAGUE (Velthuisen), PCKK, 1,050 metres, 8.40 to 9.40 p.m. (Friday), Concert.

HILVERSUM, 1,030 metres. 8.10 to 10.10 p.m. (Sunday), Concert and News.

IJMUIDEN (Middelraad), PCMM, 1,050 metres. Saturday, 8.10 to 9.40 p.m., Concert.

AMSTERDAM, PA 5, 1,050 metres (Irregular). 7.40 to 9.10 p.m., Concert.

AMSTERDAM (Vas Diaz), PCFF, 2,200 metres, 8 a.m. and 4 p.m., Share Market Report, Exchange Rates and News.

DENMARK.

LYNGBY, OXE, 2,400 metres. 7.30 to 8.45 p.m., Concert (Sunday excepted).

GERMANY.

BERLIN (Koenigswusterhausen), LP., 4,000 metres. (Sunday), 10 to 11 a.m., Music and Lecture; 2,700 metres, 11 a.m. to 12 noon, Music and Lecture. Daily, 4,000 metres, 6 to 7 a.m., Music and Speech; 11.30 a.m. to 12.30 p.m., Music and Speech; 4 to 4.30 p.m., News.

EBERSWALDE, 2,930 metres. Daily, 12 to 1 p.m., Address and Concert; 7 to 8.30 p.m., Address and concert; (Thursday and Saturday), 7 to 8 p.m., Concert.

BERLIN (Yol Haus), 400 metres. 8 to 9 p.m. Concert.

CZECHO-SLOVAKIA.

PRAGUE, PRG, 1,800 metres. 7 a.m., 11 a.m. and 3 p.m., Meteorological Bulletin and News; 4,500 metres, 9 a.m., 2 p.m., and 9 p.m., Concert.

KBEL (near Prague), 1,000 metres. Daily, 6.30 p.m., Concert, Meteorological Report and News.

SWITZERLAND.

GENEVA, HB 1 (Radio Club de Genève). Temporarily suspended. LAUSANNE, HB 2, 1,100 metres (Monday and Wednesday), 4 p.m., Concert; 1,000 metres (Friday and Saturday), Concert.

SPAIN.

MADRID, 1,650, 2,200 metres (Irregular). 12 to 1 p.m., Tests. MADRID, PTT, 400 to 700 metres. 4 to 5 p.m., Tests.

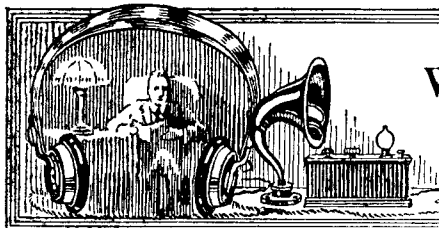

WITH THE SOCIETIES

Particulars of Membership of any Society can be obtained on application to the Secretary. Societies marked with an asterisk are affiliated to the Radio Society of Great Britain.

The Hounslow and District Wireless Society.*

The Society has been very active during the last month, several very interesting and instructive lectures having been delivered. On Thursday, January 3rd, Mr. Stanley Ward gave an excellent lecture entitled "Measuring Instruments used in Radio Work," providing a considerable amount of useful information.

On Thursday, January 10th, an interesting evening was provided by Messrs. Newson and Stevenson, who discoursed on and demonstrated a three-valve resistance coupled L.F. amplifier.

On Thursday, January 24th, Mr. Geo. A. V. Sowter delivered an instructive lecture on "Measuring Instruments," also demonstrating an improvised hot wire instrument, from which very good results were obtained. Mr. John Steel visited the Society on January 31st, and gave a very interesting lecture on "Wireless in Wartime," relating some of his experiences when in the Balloon Section of the R.A.F.

Particulars of membership may be obtained from the Hon. Secretary, Arthur J. Myland, 219, Hanworth Road, Hounslow.

Barnet and District Radio Society.*

The history and aims of the amateur radio movement in this country formed the subject of an intensely interesting lecture given at a meeting of the Society on Monday evening, February 4th, by Mr. L. F. Fogarty, former treasurer of the Radio Society of Great Britain.

The lecturer dealt briefly with the early work of the pioneers of wireless, the gradual evolution of the "amateur," and the subsequent formation of local societies, arriving at the year 1913, when he, with other enthusiasts, began the formation of a parent society, first called the "London Wireless Club," later the "Wireless Society of London," and now known far and wide as "The Radio Society of Great Britain." During the war period, he said, the parent society, in common with local societies, had to suspend activities as the majority of the officers and members joined His Majesty's forces. During the war the science of radio and the speedy production of wireless sets and component parts developed remarkably, and, when, in 1919, the Society re-commenced its activities, it had the backing of a large body of first-class amateurs who had gained invaluable experience whilst serving with the wireless sections of the forces during hostilities. In conclusion, Mr. Fogarty briefly outlined the future plans of the parent society and emphasised the importance of the work which local societies were doing. He extended to the Barnet Society the best wishes of the Radio Society of Great Britain.

It has been arranged for the members

to visit the Barnet Telephone Exchange. Permission has also been secured for a party of ten to pay a visit to the London station of the B.B.C., and to the transmitting station of the Marconi Company.

The Secretary would like to remind local radio enthusiasts that there is still room in the Society for more members, and he would be pleased to hear from anybody wishing to join. Some very interesting events have been arranged for the future meetings.

Hon. Sec., J. Nokes, Sunnyside, Stapylton Road, Barnet.

Tottenham Wireless Society.*

On January 29th Mr. Cole lectured on "Electro Magnetic Waves." He explained that X-rays, light, heat and radio were identical forms of energy radiation, varying effects being due to varying wavelengths. An interesting point arose in the discussion which followed as to whether a receiver within a wavelength's distance from the transmitter would operate. This point was cleared up at the end of the business meeting held on February 2nd. Mr. Holmes said that within a quarter wavelength distance a receiver would not operate. The explanation given was that until that distance from the transmitter a wave was not in existence as its two components (potential or static and current or kinetic) were out of phase. Hertz had shown that these components were in phase at about a quarter of a wavelength from the transmitter and a true wave was then formed.

Hon. Sec., S. J. Glyde, 137, Winchelsea Road, Bruce Grove Tottenham, N.17.

Golders Green Radio Society.*

The President, Mr. Maurice Child, gave a lecture on "The Elementary Principles of Reception," to an interested audience on Wednesday, January 16th. His parallels from the domestic bath were much appreciated by the members and his discourse was punctuated by ready wit and humour. Mr. Child exhibited a station tester or wavemeter and offered to assist members to calibrate their own meters if they cared to bring them along to a subsequent meeting.

The lecturer on Wednesday, February 6th, was Mr. L. Bland Flagg, who dealt with the subject of "Plug and Jack Switching." He illustrated his remarks with diagrams on the blackboard and drew special attention to the best types of jack to use on short wavelengths, and for H.F. work with a view to reducing capacity effects. He concluded with a demonstration on a five-valve set built by himself.

The Society is paying particular attention to the annoyance of oscillation, and the Secretary will be glad to receive log reports, duly authenticated, of this nuisance occurring in the district with a view to prompt action to secure its abatement.

Owing to the recent closing down of the Finchley Society the Golders Green Radio Society has received a large influx of members; but there is still room for a few more and full details can be obtained of the Hon. Sec., W. J. T. Crewe, "The Dawn," 111, Prince's Park Avenue, Golders Green, N.W.11 (Hampstead 3792). The annual subscription is 10s. 6d. Entrance fee 5s.

Lewisham and Catford Radio Society.*

"Waves and Wave Form" was the subject of a lecture given by Mr. Exell, B.Sc., on Thursday, February 8th.

The lecturer dealt very thoroughly with simple harmonic, longitudinal and transverse waves in light, heat, sound and wireless.

Membership is open to all in the district interested, who apply to the Hon. Sec., C. E. Tynan, 62, Ringstead Road, Catford, S.E.6.

The Wireless Society of Hull and District.*

A stimulating debate was held recently on the question, "Has the Advent of Broadcasting Proved Beneficial to the Amateur?" Mr. A. W. Spreckley, who lead for the affirmative, maintained that since broadcasting arrived, the enthusiasm of the experimenter had grown, that component parts of apparatus can be now more readily obtained locally, that the attitude of the press towards the experimenter has altered for the good, and finally that the field for carrying out experiments has been immensely enlarged.

Mr. Hy. Strong (Vice President) opposed and said that prior to broadcasting, experimental licences were easy to obtain as compared with now. There was very little interference in those days. This could no longer be said on account of the nuisance of radiation. The hours of the genuine experimenter are now limited, and the amateur transmitter is badly hit.

The discussion was afterwards thrown open, and many members took part. At the conclusion a vote was taken and resulted in a large majority for the affirmative (Mr. Spreckley).

A visit to the offices of the *Hull Daily News*, to inspect the Creed machines in operation proved most interesting.

Mr. J. Brazendale, who at the moment is the only member to hold a transmitter's licence, recently gave a very informative chat on a C.W. transmitter. He laid particular stress on the absolute necessity of having an efficient aerial and earth system, and proceeded to give particulars of experiments which he had tried in that direction.

Volunteers are required to read papers or to give short talks on any topic in connection with wireless.

Intending members will be welcomed. Hon. Sec., H. Nightscales, "Glen Avon," Cottingham Road.

Wimbledon Radio Society.*

A lecture on "High Frequency Currents" was delivered by Mr. C. E. P. Jones on Friday, February 1st. Having differentiated between high and low frequency currents, the lecturer proceeded to explain the vagaries of the former, and spoke of the increase of radiation in proportion to the increase of frequency. An explanation of the "skin effect" was also given, and the lecturer described how, in line work, it is possible to send speech currents (high frequency) along a conductor and simultaneously use the conductor for the transmission of telegraphy (low frequency).

Hon. Sec., C. G. Stokes, 6, Worpole Avenue, Wimbledon, S.W.19.

Fulham and Putney Radio Society.*

The Flewelling circuit was treated in a short lecture delivered by Mr. Scanlon on February 1st. Demonstrations of different types of receiver were given by Messrs. Aland, Galton and Fryson, excellent results being obtained.

Application forms for membership can be obtained from the Hon. Sec.,

tion of a four-valve set." The lantern slides, together with the explanation given by the lecturer, enabled the audience clearly to understand the way in which coils are manufactured with the object of giving low self-capacity. The lecture was followed by questions and answers between the members of the audience, and a discussion of a valve and crystal reflex circuit.

Hon. Sec., H. T. P. Gee, 51 and 52, Chancery Lane, W.C.2.

Northampton and District Amateur Radio Society.

At the Society's meeting on February 4th, the chairman announced the results of a series of "Megger" tests on the insulating properties of various materials used in the construction of wireless parts and of apparatus, such as headphones, condensers and grid leaks. The accuracy of some of the last-named after several years' use and storage was remarkable. A series of interesting experiments was afterwards performed by Mr. A. J. Smith, who compared by means of a milliammeter the plate currents consumed by various types of valve under different conditions.

A most interesting and instructive evening was concluded by a demonstration by Mr. Wigglesworth, who kindly brought along a three-valve set and loud-speaker.

Gen. Sec., A. Passmore, Burnage Works, Didsbury, Manchester.

Bournville Radio Society.

Dr. J. R. Ratcliffe gave a most enjoyable lecture on Tuesday, December 18th, concerning the arrangement of the Eiffel Tower Wireless Station, situated in Paris. The lecture was illustrated by lantern slides showing views of the Tower grounds, the beauty of which had been preserved by placing the necessary buildings incidental to such wireless stations underground. The lecture included an explanation of the Holweck valve and pump. Dr. Ratcliffe stated that there is a special depot at Eiffel Tower where English enthusiasts can make written enquiries regarding wireless telegraphy, and that such enquiries are earnestly invited.

On Tuesday, January 1st, Mr. E. E. Wakeman demonstrated his three-valve receiving set (HF, D, LF), which had been constructed from information given

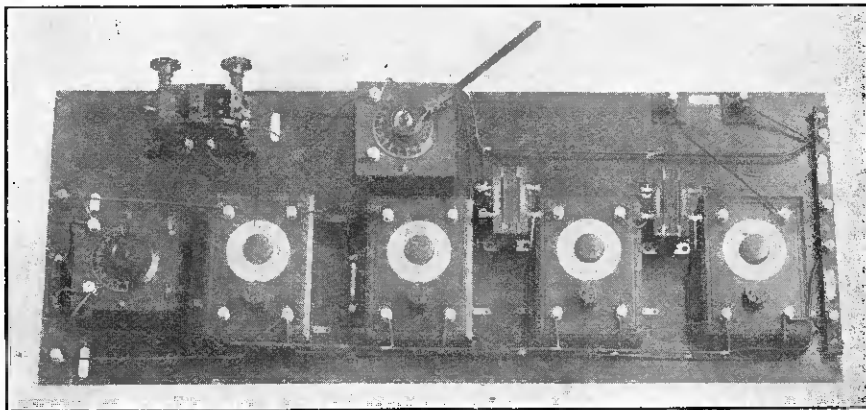

An efficient experimental panel, belonging to Mr. Norman Harvey, of Thornton Heath. On substituting a variometer for the left-hand condenser and coil, WGY and KDKA have been clearly heard, with an aerial 40 feet long, only 8 feet high at free end and 18 feet high at the lead-in.

B. L. Honston, 125, Hurlingham Road S.W.6.

Sheffield and District Wireless Society.*

Mr. W. Burnet lectured to the Society on "Modern Wireless Problems," on February 1st. He explained that the design of an effective receiving set is a matter of intelligent compromise. A number of circuits, exhibiting novel features, were discussed, and apparatus embodying some of these circuits was demonstrated at the close of the lecture. As always, an interesting discussion ensued.

Hon. Sec., R. Jakeman, "Woodville," Hope, Sheffield.

Croydon Wireless and Physical Society.

At the meeting of the Society held at the Croydon Camera Club Room, East Croydon, on January 14th, 1924, Mr. C. Creswick Atkinson, gave a lecture, illustrated by lantern slides and black-board sketches, on "the construction of duo-lateral coils as manufactured by the Igranic Company, and the construc-

Hon. Sec., S. H. Barber, M.B.E., 51, College Street, Northampton.

Sale and District Radio Society.

Members of the Society have recently been busily engaged in the construction of a six-valve set which is now nearing completion. Would-be constructors and others interested in the work are warmly invited to join the Society. An excellent syllabus has been arranged, including rambles in the summer months. On January 19th the Society paid an interesting visit to 2ZY.

Hon. Sec., H. Fowler, Wh.Ex., A.M.I.M.E., "Alston," Old Hall Road, Sale.

Hans Renold, Ltd., Social Union (Radio Section).

A wide field was covered in a lecture given on February 5th, by Mr. J. Hands, on the subject of "Crystal and Simple Valve Circuits." At the conclusion of his remarks the lecturer was called upon to answer a number of questions not only upon the subject in hand but upon aeri-als and earth leads.

to the Society by a former lecturer, Mr. Winkles, of Hall Green, who testified as to its selectivity.

An enjoyable social evening was held on Saturday, January 12th.

Asst. Hon. Sec., H. Wightman, Messrs. Cadbury Bros., Ltd., Bournville Birmingham.

Radio Section, West Bromwich Engineering Society.

At a special general meeting held on February 1st, a radio section of the above Society was formed.

The first meeting of the section will be held on Friday, February 29th, at 7.30 p.m., at the Technical School, when Dr. J. R. Ratcliffe, President of the Birmingham Wireless Club, will give a lecture on FL, illustrated by lantern slides.

Particulars of membership may be obtained from the Hon. Asst. Sec., H. C. Richardson, 57, Birmingham Road, West Bromwich.

Questions & Answers

Solutions of Readers' Difficulties

1. All questions are answered through the post. A selection of those of general interest is published.
2. Not more than four questions may be sent in at any one time.
3. Every question should be accompanied by a postal order for 1/-, or 3/6 for four questions, and by a coupon taken from the current issue.
4. Alternatively, advantage may be taken of our free service by using the free coupon. This appears in the first issue of each month, and is valid during the current week only.

"C.T.L.H." (Sunbury) has a two-valve and crystal receiver which is not very selective, and asks how this circuit may be improved.

With the present arrangement of your receiver, considerable damping is introduced by the crystal detector. We recommend that you use a valve detector. A valve detector will in general not produce the damping which is caused by a crystal detector, and there is the advantage that the valve operates as an amplifier as well as a rectifier, and it will be possible to use reaction. In the diagram (Fig. 1) a valve detector is connected after the first stage of tuned anode high frequency amplification, and the reaction coil is coupled with the tuned anode coil. A circuit of this sort will be found much easier to operate than a receiver which employs a crystal as rectifier after high frequency amplification.

a 4-volt accumulator is used, it is found that the actual voltage applied to the filaments of the valves is often as low as 3.5, owing to the voltage drop through the internal resistance of the accumulator and the wiring of the receiver.

"A.M." (Westgate) asks what modifications are necessary in order to use "D.E.R." valves instead of ordinary "R" type valves.

When the valve is used as a detector, the grid leak should be connected with the positive L.T. lead, and when used with a plate voltage of 60 to 80 volts in an L.F. amplifier it will be found an advantage to connect a single cell in the grid circuit. There will be no need to change the ordinary 7 ohm filament resistances if the valves are supplied from a 2-volt accumulator.

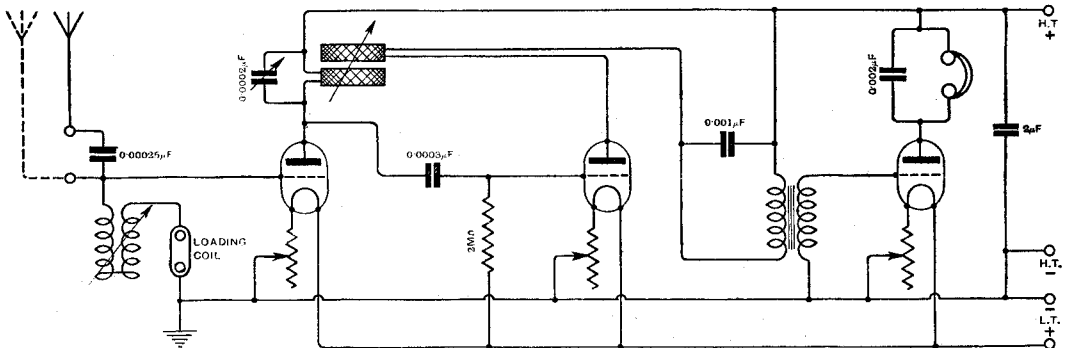

Fig. 1. "C.T.L.H." (Sunbury). A three-valve receiver with one stage of H.F., detector and L.F. The reaction coil is coupled to the anode coil.

"W.H.S." (Leeds) asks whether a 4-volt or a 6-volt accumulator is best for use with "R" type valves.

We recommend the use of a 6-volt accumulator, together with adequate filament resistances. When

"J.F.A." (Warlingham) has a two-valve L.F. amplifier which persists in oscillating at audio-frequency. The amplifier is correctly wired, and all the components are of good quality. He has tried the use of grid cells

without success, and asks what other methods are available for preventing self-oscillation.

Self-oscillation in the low frequency portions of a wireless receiver is sometimes caused by a high tension battery having an abnormally high internal resistance. The H.T. battery is common to the plate circuits of all the valves in the receiver, and any fluctuations in current due to one of the valves will establish an oscillating E.M.F. across the ends of the H.T. battery which will be communicated to the other valves. We recommend that you connect a large reservoir condenser of not less than $2\mu\text{F}$. across the H.T. battery. If necessary, resistances of the order of 0.5 to 1 megohm should be connected across the secondary windings of the intervalve transformers.

the H.F. circuits, when the switches 1 and 2 are to the left, the tuned anode circuits are connected in the plate circuits of the valves. When the switches are to the right, the resistances are joined in the plate circuits. A switch when in the left-hand position joins the tuner to the second valve and cuts out the first valve. Switch 4 is the reaction coil reversing switch. Switch 5 is connected to the circuits of the note magnifier, and when this switch is in the left-hand position the note magnifier is disconnected.

"W.S.P." (Bromley), asks whether, in view of the results of some of the recent transatlantic tests, the best receiver to use for short wave reception should consist of a valve detector

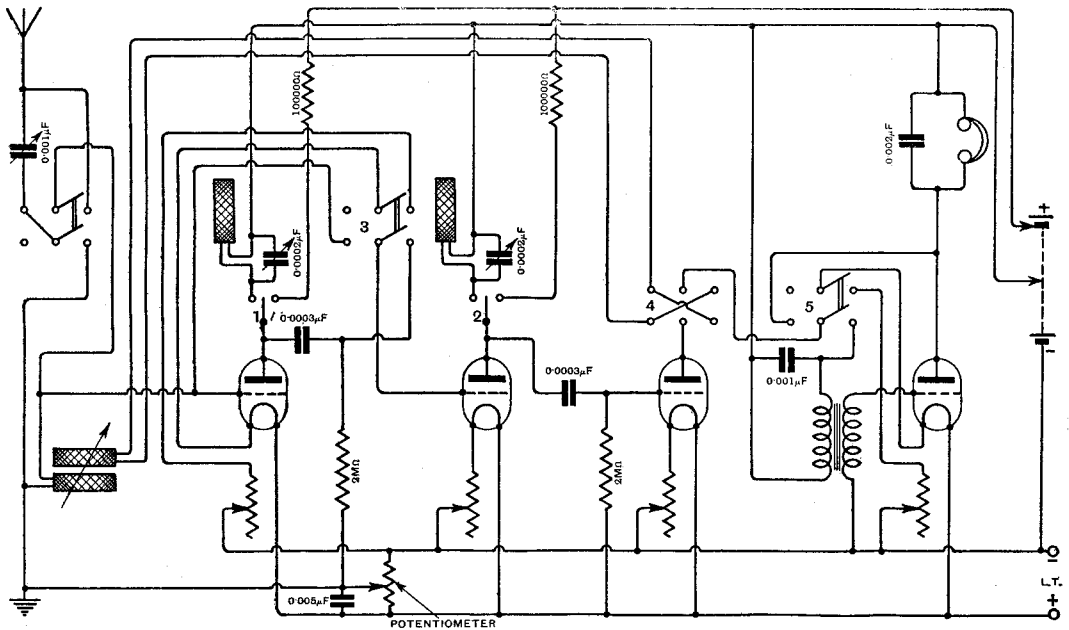

Fig. 2. "F.W.B." (Liverpool). A receiver with two stages of H.F. amplification, detector and note magnifier. Resistance or tuned anode H.F. couplings may be used.

"P.K.C." (Leicester), wishes to use two duolateral coils mounted in a two-coil holder as a high frequency coupling, and asks if it will be necessary to tune both windings.

If the coils are tightly coupled together, it will be necessary to tune only one of them. With a loose coupling, however, it becomes necessary to tune both coils, but by doing so it is possible to obtain a very high degree of selectivity.

"F.W.B." (Liverpool) asks for a diagram of a four-valve receiver (2-V-1), with switches to cut out the first and last valves, and to change from tuned anode to resistance capacity coupling between H.F. valves.

The diagram is given in Fig. 2. Referring to

with reaction followed by either one or two stages of L.F.

The success obtained without the use of H.F. amplification when receiving faint signals on short wavelengths may be attributed to the simplification of the tuning adjustments, rather than to the omission of high frequency amplifying valves. There can be no hesitation in stating that provided adequate attention is given to the design of the H.F. coupling, the range of the receiver would be considerably increased by the addition of H.F. amplification. The failure of H.F. amplifiers on short wavelengths is almost always due to stray capacities in the valve and wiring which prevent the proper building up of an amplified oscillating potential across the grid circuit of the detector valve.

THE WIRELESS WORLD AND RADIO REVIEW

THE OFFICIAL ORGAN OF THE RADIO SOCIETY OF GREAT BRITAIN.

No. 237. (No. 22.
Vol. XIII.)

FEBRUARY 27th, 1924.

WEEKLY

EDITOR:
HUGH S. POCOCK.

RESEARCH EDITOR:
PHILIP R. COURSEY, B.Sc., F.Inst.P., A.M.I.E.E.

ASSISTANT EDITOR:
F. H. HAYNES.

QUESTIONS AND ANSWERS DEPARTMENT:
Under the Supervision of W. JAMES.

CONTENTS

	PAGE
An International Amateur Organisation? By the Editor	668
An Improvement in Frame Aerial Connections. By W. B. Medlam and A. O. Schwalde - - -	669
Another Application of the Neon Lamp. By J. F. Payne	674
The Three-Electrode Valve. By W. Sydney Barrell -	676
"Results." By Sydney Burne - - - - -	680
Some Useful Components - - - - -	682
A Universal Receiver. By S. J. Hex - - - - -	683
Around the Wireless World - - - - -	686
An Instrument Frame. By F. H. Haynes - - - - -	689
Inventions and Novel Ideas - - - - -	690
Correspondence - - - - -	692
With the Societies - - - - -	693
Questions and Answers - - - - -	695

THE EDITOR will be glad to consider articles and illustrations dealing with subjects within the scope of the Journal. Illustrations should preferably be confined to photographs and rough drawings. The greatest care will be taken to return all illustrations and manuscripts not required for publication if these are accompanied by stamps to pay return postage. All manuscripts and illustrations are sent at the Author's risk and the Editor cannot accept responsibility for their safe custody or return. Contributions should be addressed to the Editor, "The Wireless World and Radio Review," 12 and 13, Henrietta Street, Strand, London, W.C.2.

SUBSCRIPTION RATES:

20s. per annum, post free. Single copies 4d. each or post free 5d. Registered at the G.P.O. for transmission by Magazine Post to Canada and Newfoundland.

As many of the circuits and apparatus described in these pages are covered by patents, readers are advised, before making use of them, to satisfy themselves that they would not be infringing patents.



EDITORIAL AND PUBLISHING
OFFICES:

12 and 13 Henrietta Street,
Strand, London, W.C.2.
Telephone: Gerrard 2807-8.

ADVERTISEMENT MANAGERS:

Bertram Day and Co., Ltd.,
9 & 10 Charing Cross, S.W.1
Telephone: Gerrard 8063-8.

AN INTERNATIONAL AMATEUR ORGANISATION ?

By THE EDITOR.

DURING the past year, and especially the last few months, amateurs almost all over the world have been in communication over very long distances. International communication between amateurs, unheard of a year or so ago, is now an everyday event, and it is anticipated that in a short while it will be possible to circle the globe with an amateur message relayed from country to country and continent to continent.

It will be remembered that the American Radio Relay League organised the first transatlantic amateur tests in conjunction with *The Wireless World and Radio Review*, whilst in succeeding tests the organisation on this side has been done by the Radio Society of Great Britain.

Prior to the first successful transatlantic amateur working the A.R.R.L. had already achieved communication over very great distances, and due to their organisation and numbers they have undoubtedly done more than any other amateur body to develop amateur activities in this direction. Under such circumstances, therefore, it is fitting that the A.R.R.L. should have taken the first step towards promoting some sort of machinery which will further efforts to develop international amateur working.

Hiram Percy Maxim, President of the American Radio Relay League, is on his way to Europe at the time of writing, and a conference between him and Dr. Pierre Corret, organiser in France of the transatlantic tests, and members of the Inter-Societies Committee, will take place in Paris on March 13th. A few days later Mr. Maxim will be in London to meet the Radio Society of Great Britain on the same matter.

Some interesting results should come out of these discussions, and amateurs will, we feel sure, await them with interest.

It is well known that already efforts have been made to introduce distinguishing signals to indicate the country of origin of amateur transmissions. Other matters to be arranged are definite times for relay transmissions, whilst in addition an enormous amount of data of extreme scientific value can be collected by a properly organised scheme set up to arrange for long distance short wave transmissions. Yet a further matter to be discussed is whether some auxiliary language such as Esperanto should be adopted officially by the international amateur organisation for use when communicating with amateur stations in foreign countries.

Opinions on this point are likely to differ considerably. There are many who consider that in view of the preponderance in numbers of the English-speaking amateurs, that others should be prepared to adopt the same language for international communications. On the other hand, English is a difficult language to learn, especially for those who are not of European origin. Esperanto, it is claimed, can be mastered in a matter of a few weeks. In any case, the fact that the executive of the A.R.R.L. has given serious consideration to the problem, and is disposed to support the adoption of an auxiliary language, ensures that the matter will have to be thoroughly gone into before amateurs as a body arrive at any binding decision.

AN IMPROVEMENT IN FRAME AERIAL CONNECTIONS.*

It is commonly assumed that "dead-end" turns in a frame aerial lead to inefficiency, and it is frequently the practice, when a tapped frame is used, to provide "dead-end" switching arrangements to cut out of circuit those turns of the frame not included in the tuned part of the circuit. In this article the conditions are discussed which will result in improved reception when a suitable number of dead-end turns are left connected.

By W. B. MEDLAM and A. O. SCHWALD, B.Sc.

DURING a series of experiments on frame aeri-als commenced by the authors some months ago it was found that the "dead-end" turns of a frame, under certain conditions, were directly helpful in increasing the voltage available for operating a valve or a crystal.

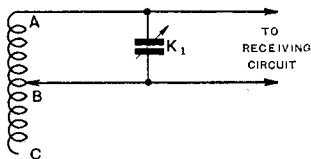

Fig. 1. Tuned frame circuit A B with "dead-end" turns B C. The potential developed across A B may be increased when B C has a suitable value.

In Fig. 1, A B C represents the winding of a loop aerial. The turns included between A and B are tuned by the variable condenser K_1 , the terminals of which are connected to the input terminals of the receiving circuit. The turns between B and C are left "dead-ended." For any given number of turns between A and B the voltage across the receiving circuit is increased continuously as the number of the turns between B and C is increased, until the portion B C of the winding becomes self-tuned, when the voltage across A B reaches its maximum value.

The maximum voltage attained when B C is self-tuned varies with the number of turns included between A and B, and there is a definite optimum number of the tuned turns A B. In the case of a pancake frame of 3 ft. side and $\frac{1}{4}$ in. spacing the best number of turns for 360 metres was found to be 7 for the tuned part A B and about 22 additional turns for the dead-ends. With this arrangement the voltage across a valve

receiving circuit was 2.3 times the greatest voltage obtainable with a plain untapped frame.

The variation of voltage (on 2 LO's carrier) with dead-end turns for a tapping at the seventh turn of this particular frame is shown by the graph in Fig. 2. When more or less than 7 turns are included in the tuned part A B (Fig. 1) the dead-end graphs are of similar shape, but give lower peak values of voltage. The adjustment of the exact length of the dead-end turns for resonance is very critical, and it would be difficult in practice to operate such a frame always at its peak output.

Instead of piling on dead-ends to the point at which they become self-tuned, an

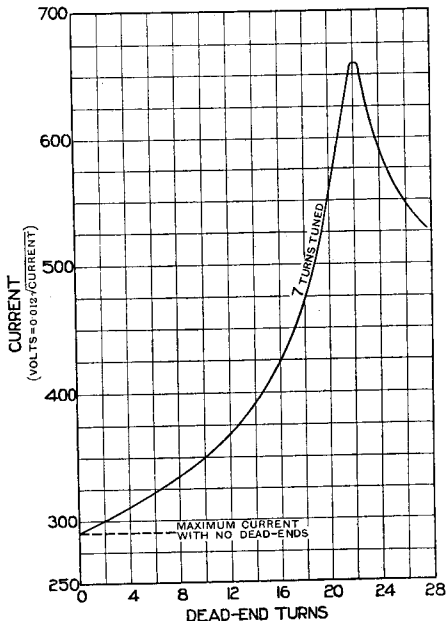

Fig. 2. Curve showing the relationship between the potential set up across the turns of a frame aerial and the number of dead-end turns in circuit.

* These experiments were made at the Chelsea Polytechnic, with facilities provided by Dr. Lownds, Head of the Physics Department.

equivalent improvement may be obtained by using a smaller number of dead-ends tuned by a separate condenser in parallel with them, as shown in Fig. 3. In this

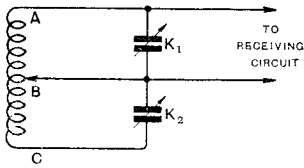

Fig. 3. The effect of the dead-end turns may be adjusted by tuning them with the condenser K_2 .

diagram AB represents the normal frame winding tuned by the condenser K_1 , and BC represents the dead-end turns tuned by the condenser K_2 . In this case, keeping the turns AB and BC fixed, the tuning on K_1 varies with the value of K_2 , and there is an optimum setting of the two condensers.

Owing to the complication of the double tuning, little work was done on this arrangement, and it was soon abandoned in favour of that shown in Fig. 4, in which a single condenser K tunes the whole winding, comprising the turns AB of the normal frame and the additional turns BC. The performance of this last arrangement is illustrated by the graphs in Fig. 5, which show how the voltage across a particular receiving set varied with the number of turns in the section BC and AB. Each full line curve shows for a given number of curves in AB, how the voltage varies with the total number of turns on the frame.

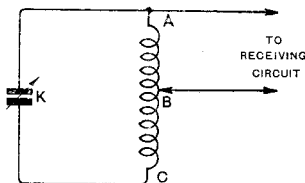

Fig. 4. To overcome the difficulty of simultaneously manipulating the two condensers shown in Fig. 3, one condenser may be employed with a wandering tapping point at B.

The number of turns in AB is indicated by the number against each graph. For example, with a frame wound with 12 turns the current would be 362 for a tapping at the third turn, 540 at the fourth turn, 553 at

the fifth turn, 511 at the sixth, 460 at the seventh, 392 at the eighth, and 200 across the whole of the frame. These current values may be converted to grid-filament voltages by means of the relation $\text{volts} = 0.012 \text{ current}$. The dotted curve is drawn through the maximum values of the dull line curves.

These curves show that for any given number of turns in AB there is an optimum number of turns in BC. Or, to put it in another way, there is a best tapping for a frame wound with any given number of turns. The curve marked "plain turns,"

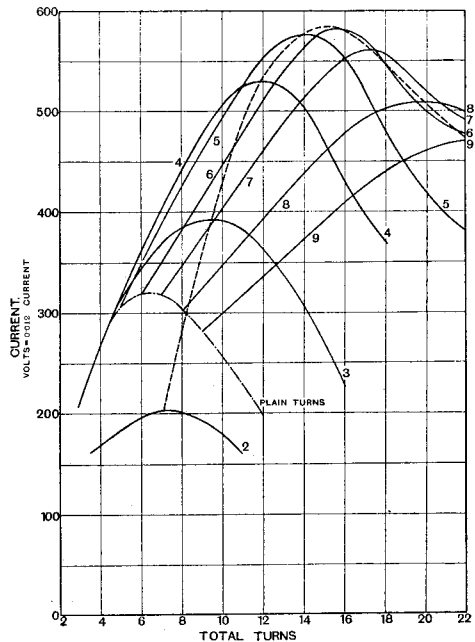

Fig. 5. These curves show how the voltage set up across the terminals of the receiver (AB in Fig. 4) varies with the number of turns made use of on the frame and also the total number of turns left on the circuit to produce a dead end.

which appears as a limiting case when the additional turns are zero, shows how the voltage varies with the number of turns in the case of an ordinary untapped frame. There is a definite optimum between 6 and 7 turns for 360 metres, but this optimum voltage is much lower than that obtainable with, say, the 14-turn frame tapped at the fifth turn, or the 16-turn frame tapped at the sixth turn. The curves refer to a 3 ft. frame of pancake type.

An exactly similar set of graphs was obtained with a solenoid type of frame of the same external dimensions, but the voltages in this case were greater. In both cases the best tapping point remained displaced about four turns from the centre of the frame over a wide range of total turns, for the particular receiving circuit connected and the frame. The position of the best tapping point depends on certain capacities of the receiving circuits, and it may be asked how can one rapidly locate this point? The answer is quite simple. The best tapping point is that point in the frame which automatically assures earth potential after the receiving set is connected to the frame.

The procedure for arriving at the correct connections to the frame is first to connect one end of the frame to the grid of the first receiving valve, making this the *only* connection of the frame to the set, and tune in a local station by means of the condenser

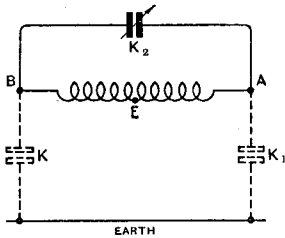

Fig. 6. Equal capacities to earth occur approximately at A and B, and thus the earth potential point E will be near the middle of the frame.

connected across the whole winding of the frame. Now tap a lead from the filament side of the set to various turns of the frame *without altering the tuning*. It will be found that for one position of the tapping lead the signals will reappear stronger than before. The tapping lead will now be connected to the earth point in the frame.

The above results are explainable from the following considerations. In Fig. 6 is shown a frame aerial AB and its tuning condenser K_2 . The frame is supposed to be insulated from earth, and is not connected to any other circuit. There will be distributed capacities between the turns of the loop and earth, which capacities may be represented by condensers K and K_1 between the ends of the loop and earth as shown. Owing to these capacities a point at earth potential will appear in the frame winding,

its location depending on the relative magnitudes of K and K_1 . Normally K and K_1 are nearly equal, so that the point E at earth potential will be very near the centre of the frame. If the end A of the frame is now connected in the grid circuit of a valve,

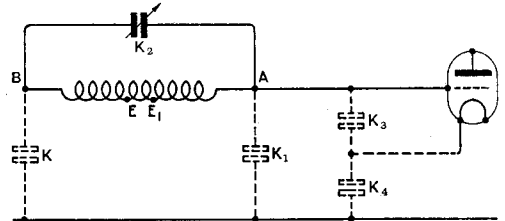

Fig. 7. When the end A is connected to grid of the receiving valve extra capacity K_3 occurs at this point, moving the apparent earth potential point of the frame to E_1 .

as shown in Fig. 7, extra capacity appears between A and earth. This extra capacity is shown in Fig. 7 as a condenser K_3 between grid and filament, in series with a condenser K_4 between the filament circuit and earth. The resultant capacity between A and earth is thus increased relatively to K , causing the point at earth potential in the frame to move from the centre towards the grid, *i.e.*, from E to E_1 . It may be noted that, with these connections, the active voltages between the grid and filament of the valve will be less than the voltage between A and earth by an amount equal to the voltage drop on the condenser K_4 . Suppose now the valve circuit is completed by connecting the filament to some point in the frame other than E, say, to the end of B of the winding

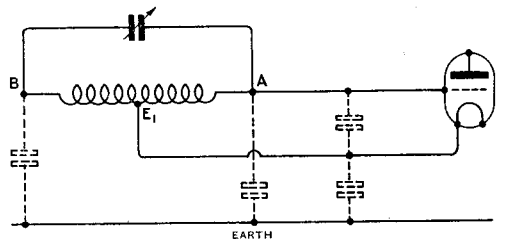

Fig. 8. The filament terminal of the receiver is here connected to the end B, which, although a normal arrangement, is not the most satisfactory.

as shown in Fig. 8. In this case the high frequency variations at B are communicated to the large capacity of the whole of the filament circuit, including the batteries, etc., and attempt to produce high frequency potential changes in this circuit. As only

a limited quantity of electricity due to the incoming signals is stored up in the frame circuit, and such a large proportion of this quantity is drawn away from B to the filament circuit, producing negligible voltage changes on this side, what is left to produce useful changes on the low capacity grid may be a comparatively small proportion of the total quantity available.

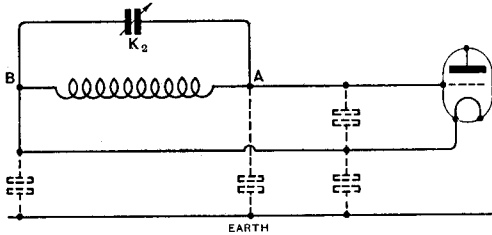

Fig. 9. This is the best method of connecting the receiver leads to the frame. E is virtually an earth potential point.

If the filament of the valve is connected to the earth potential point E of the frame, as shown in Fig. 9, no high frequency energy flows through the filament circuit, and the quantity of electricity available for producing voltage variations on the grid is actually greater than if the filament is connected to any other point between E and B, although between A and any point in this part of the winding the open circuit E.M.F. is probably greater than that between A and E.

It might be thought that if the quantity of energy in the frame is increased the grid filament P.D. would then be greater across the whole frame by regenerative action. But the tapped frame connection shown in Figs. 4 and 9 do, even in this case, give stronger signals than the plain frame. With the frame circuit on the point of oscillation it is almost impossible to make any measurement of signal voltage. However, working

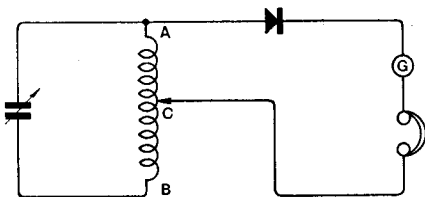

Fig. 10. As the tapping point C moves from B to A a maximum galvanometer reading is obtained at approximately the virtual earth potential point of the frame.

under these conditions with shunted telephones in the plate circuit of a valve, the balance of the results was decidedly in favour of the tapped frame.

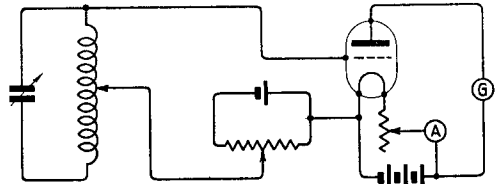

Fig. 11. Frame connections for voltage measurements.

Apart from the question of signal voltage, the tapped frame has two other important advantages. First, it is much more stable than a normally connected frame when used with a high frequency amplifier. It is usually possible to work with an efficient tuned anode, without any damping device, with the frame well off the oscillation point. Secondly, a wider range of wavelengths is possible with a given tuning condenser when using the tapped frame, as the valve capacities are not then directly in parallel with the tuning condenser.

It may be mentioned that the earth tapping on a frame is quite independent of the wavelength to which the frame is tuned.

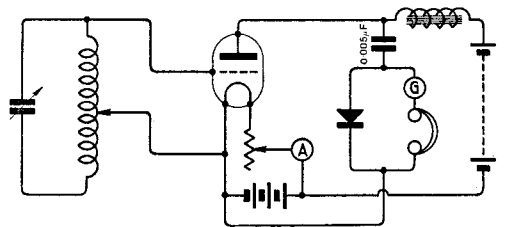

Fig. 12. Connections for voltage determinations, used for the preparation of the curves shown in Fig. 5.

A word as to the method of obtaining the above results. In order to find out whether the tapped frame was of general application, its performance in connection with a number of different circuits has been investigated. Details of the method of measurement in three of these circuits are given below.

In Fig. 10 the tapped frame ABC is shown connected to a plain crystal circuit, a sensitive galvanometer G being connected in series with the crystal and telephones. As the telephone tapping was moved from

B to A the galvanometer readings increased to a maximum at the earth potential point C and then decreased.

A circuit used for voltage measurements is shown in Fig. 11, in which a valve voltmeter on Moullin lines is employed. The readings of the galvanometer G gives a measure of the P.D. between the grid and filament of the valve. The voltmeter was calibrated on low frequency A.C. A Marconi "R" valve was used, and, in order to reduce the capacity to a minimum, no valve holder was employed, the wires to the valve being soldered direct on the valve pins. With this arrangement the best tapping was located very near the centre of the frame.

The results plotted in Fig. 5 were obtained with the connections shown in Fig. 12. The inductance L consisted of a 2,000 ohm ear-piece. An "R" valve was used in an ebonite valve holder. Readings of the galvanometer G were taken as a measure of the P.D. between grid and filament, and these readings were reduced to a voltage basis by comparison with the voltmeter of Fig. 11, the two circuits being connected in parallel for this purpose. It was noticed that there was an appreciable loss of voltage due to the ebonite valve holder.

A reflex circuit, which oscillated easily when connected across the whole frame, was perfectly stable when connected to the earth point of the frame, and the speech was

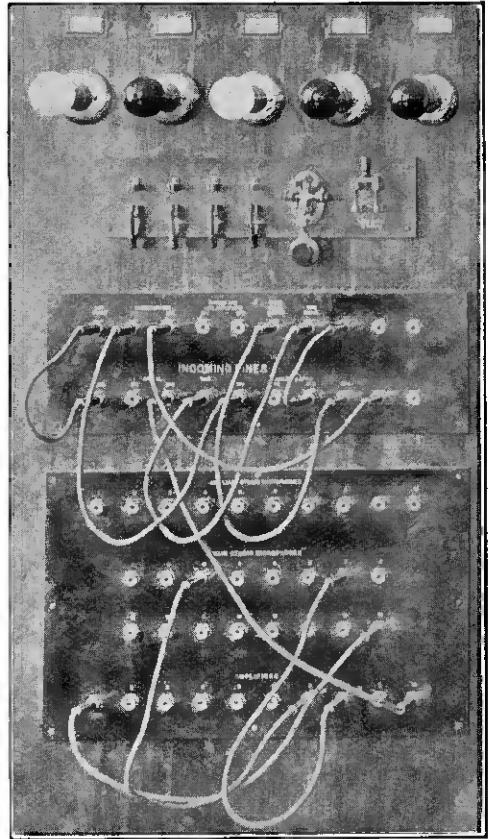

The control board at WGY.

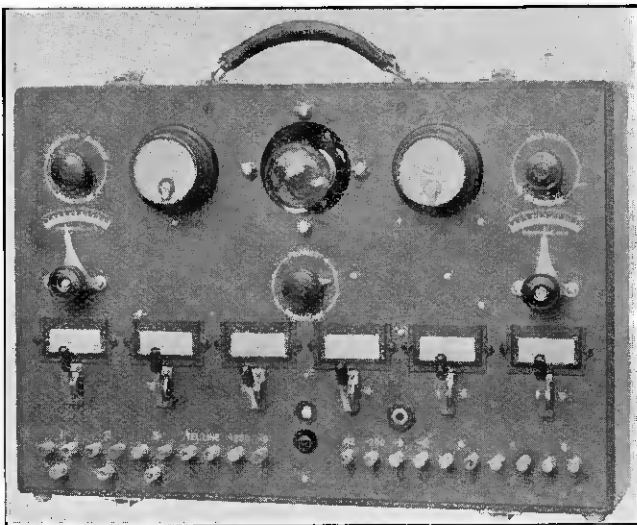

Control equipment used for outside transmissions broadcast from WGY.

clearer. The relative signal strengths were estimated by shunting the telephones in the plate circuit. Signals disappeared with a 20 ohm shunt on the whole frame, but were quite clear with the same frame tapped at the earth point near the centre.

THE CONTROL AT WGY.

The illustrations show the equipment used at WGY (Schenectady) for bringing into operation the studio or external microphones. Signalling lamps between transmitter and studio are fitted to the connector panel. Amplification control is also provided.

ANOTHER APPLICATION OF THE NEON LAMP.

A USEFUL PLATE CURRENT REGULATOR FOR D.C. MAINS.

The use of lamps and smoothing circuits for providing suitable plate current voltages for D.C. supply mains is well known. In this article a neon lamp is introduced in series between the supply and the receiver for the purpose of limiting the current. It also serves as an indicator for fluctuations in plate current due to signals or oscillation, which produce a change in the brightness of the glow.

By J. F. PAYNE.

THE principle used is that of dropping the excess volts across a neon tube (or "Osglim" lamp), together with a smoothing and filter circuit. The unit can be made up very compactly, as shown in the photograph, and the actual cost did not exceed 15s. The values of the condensers are 3 mfd. on the input side and 2 mfd. on the output side. The chokes are of the well-known "Fullerphone" type. They are iron-cored, and have a resistance of 500 ohms.

Two different output voltages are available, depending upon the way in which the lamp is inserted in the holder. High voltage (60-70 volts) is obtained when the glow is round the large electrode, while when the glow appears to be round the small electrode a voltage of about 50 is obtained.

A circuit diagram is given, and it will be seen that the assembly of the unit is within the scope of the veriest novice, calling for no difficult constructional work.

It is necessary when using this arrangement to either use a counterpoise system or put a condenser (say 2 mfd.) in series with the earth lead of the receiver. Even if you have ascertained which side of the mains is earthed, on no account bring either of them in contact with the receiving earth. More will be said with reference to this point later.

It is advisable to have the neon tube in the live side of the mains. It will be noticed from the circuit diagram that one input terminal is marked "live" and the other "dead." This does not indicate which is positive or which negative. If the negative side of the mains is earthed, then one can consider that the live output terminal is the positive one, but if the supply mains have a positive earth then the dead output terminal is positive. The live wire can generally be ascertained

from the fact that all switches are in this lead, but methods of testing for this have been mentioned in this journal from time to time. (One can generally get a shock from

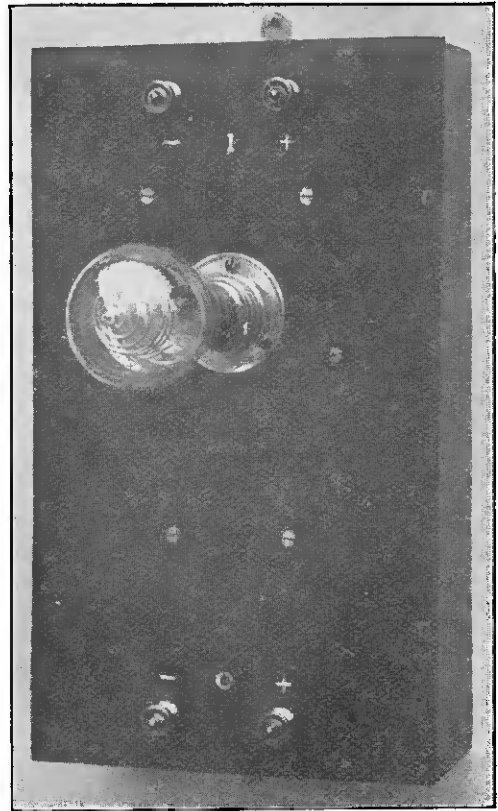

H.T. feed apparatus for use on direct current supply mains.

the live side to earth!). For finding the positive and negative lead one can make use of pole-finding paper or a glass of acidulated water, when gas is more freely liberated from the negative than the positive.

With this system it has been found that the slight hum due to commutator ripple does not prove at all troublesome, even when

and all that will happen is that the neon lamp will light to full brilliancy.

I am sure that many who install this system will resolve never again to be bothered by H.T. batteries. Apart from its freedom from trouble and expense, experimenters will find a great deal of interest in investigating the behaviour of the neon tube. For instance, with a detector and two stages of L.F. amplification it is possible, with the telephones out of circuit, to "sight read" loud C.W. stations by the fluctuations in H.T. current drawn through the tube. The lamp

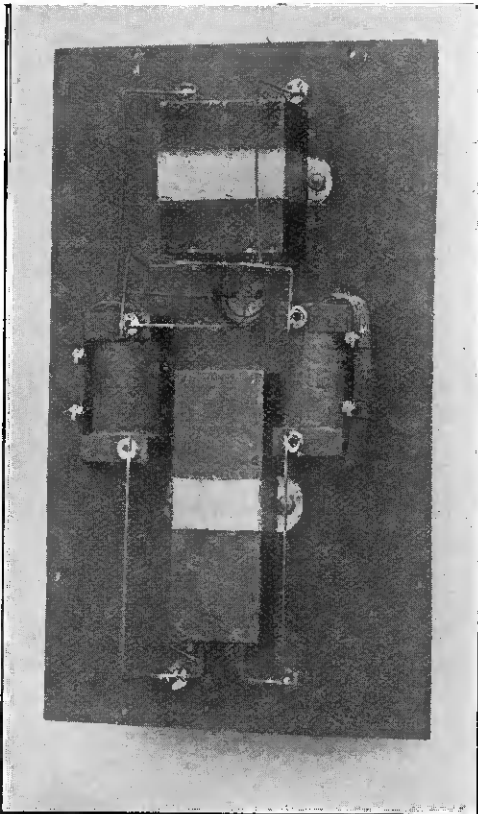

The underside of the panel, showing the layout and method of mounting the chokes and condensers.

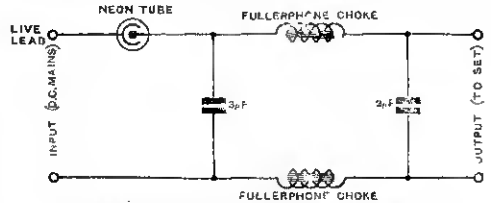

Circuit connections of smoothing set.

also furnishes an indication as to whether the receiving circuit is oscillating or not.

It is generally advised that when the neon tube is used for wireless work the balancing resistance should be taken out of the cap. In fact, the manufacturers are now supplying lamps in which no resistance is included. For the particular use mentioned here, however, it is found that the resistance is necessary. Its omission sometimes causes the lamp to discharge intermittently at a fairly low frequency, giving rise to a troublesome noise in the telephones.

STATION 2 HF.

using two stages of low-frequency amplification. For loud speaker work on broadcasting the system is ideal, and dry battery noises are eliminated. Omission of the series earth condenser will make the hum more prominent, hence the warning not to earth the mains. With reference to the advice to insert the neon tube in the live (or unearthed side) of the mains, it will be seen that with this arrangement one automatically guards against any damage being done in the event of accidentally earthing the H.T. lead. It is impossible, also, to burn out valve filaments by a wrong connection of the H.T. source, as the neon tube is rated at 5 watts, and will not pass more than 50 milliamperes on full load. One may short circuit the output terminals of the unit

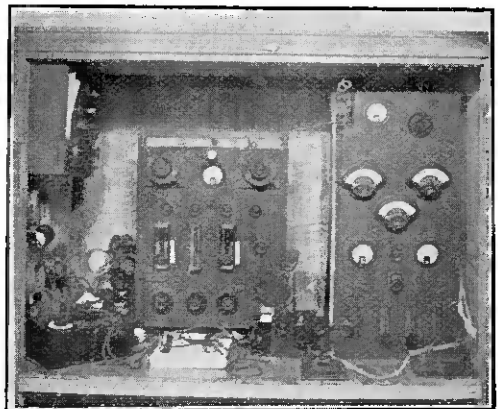

Operated by Mr. W. G. Gold and located at Four Oaks. This station has worked with Italian 1 MT.

THE THREE-ELECTRODE VALVE.

The following notes deal with two very important quantities, the amplification factor and the internal impedance.

By W. SYDNEY BARRELL.

WHILE the "magnification" of a valve is a function of its structural dimensions, yet in practice this factor is found to vary somewhat according to applied potentials and therefore its operating conditions. For example, the effect of filament temperature on the magnification factor is shown in Fig. 1, where the magnification measured at constant anode and grid potentials is plotted vertically. Below a definite filament temperature, the magnification is seen to fall off very rapidly, but it is further to be noted that the curve flattens out, thus indicating that no gain is obtained by running the filament above a certain brilliancy and, since a brighter filament means a shorter life, satisfactory operation and long life can be obtained by suitably regulating the filament current. The variation of magnification with anode volts is shown in Fig. 2, where again the

amplification is seen to rise fairly rapidly to a maximum value.

If now the magnification factor is plotted as a function of grid potential, the anode and

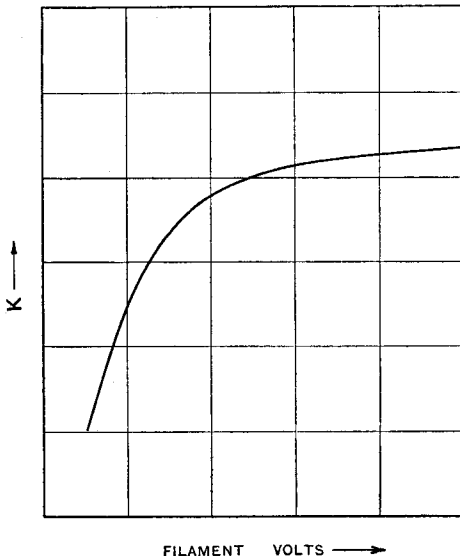

Fig. 1.

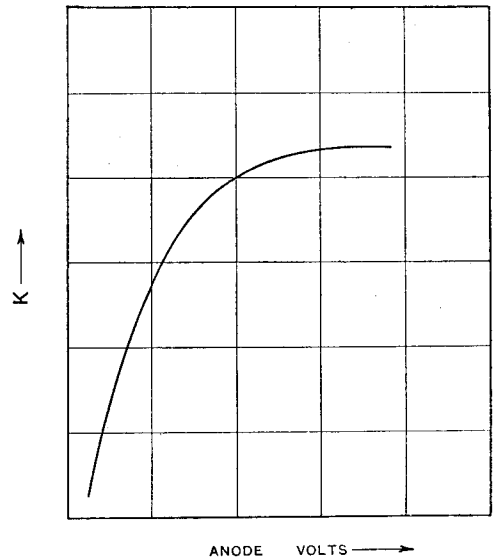

Fig. 2.

filament potentials remaining constant, we shall get a curve of the nature depicted in Fig. 3, from which we see that the magnification factor is constant over a limited range of grid voltage, but the falling off in the magnification value will depend upon the anode voltage. The higher this voltage the less the magnification factor will vary, particularly for negative grid potentials. That is to say, the range of constant magnification will be increased particularly for negative grid voltages. The noticeable drop for positive values of grid potential may probably be due to the fact that owing to grid current being established, the effective grid voltage is reduced, and consequently

the magnification factor will work out too small. In any case the longer the operating range of the valve the longer the range over which this factor remains constant.

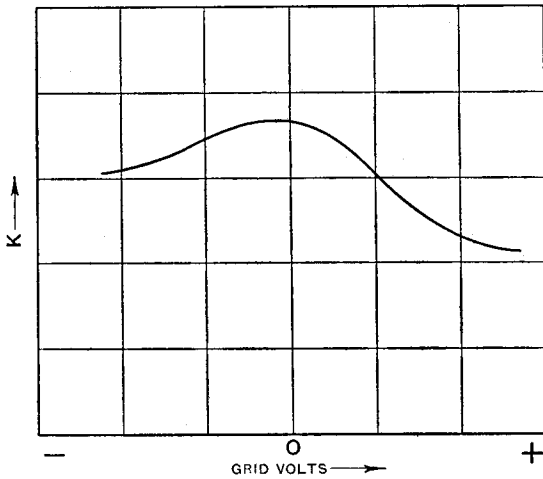

Fig. 3.

The resistance of a valve is also a function of the design, but in addition varies very considerably with the filament and anode potentials. Taking the resistance as a function of plate voltage at some fixed grid potential, we get a curve of the nature of that shown in Fig. 4, from which we see that at low anode voltages the resistance

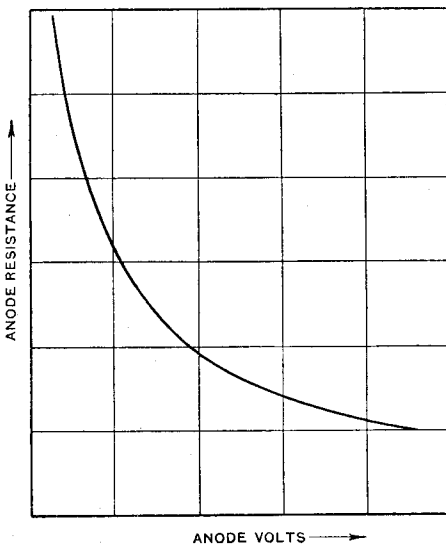

Fig. 4.

is high, but decreases as the anode voltage is increased. Moreover, this decrease in resistance is rapid at first, after which the curve flattens out.

If now we plot the impedance as a function of grid potential, keeping the anode and filament voltages constant, we get a curve showing that the resistance decreases to some minimum value and afterwards increases, see Fig. 5. The resistance thus undergoes extreme variation, and the minimum is given at the point of inflection on the anode current-grid volts characteristic. These impedance curves will also be moved bodily

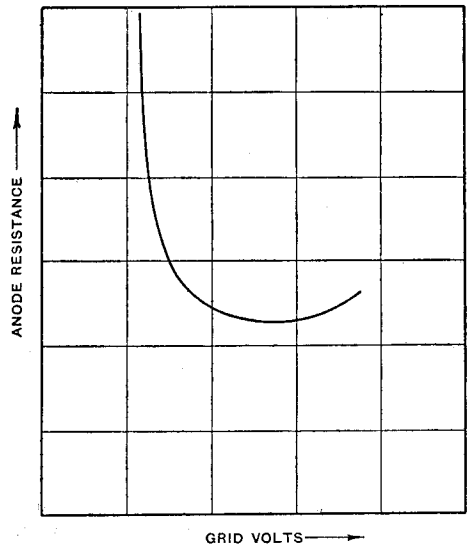

Fig. 5.

to the left by an increase in anode voltage. This must necessarily follow because the anode current-grid volts characteristics move to the left with increased anode volts and the region of minimum resistance in Fig. 5 corresponds to the straight part of the anode current-grid volts curve.

From the foregoing, then, it will be evident that the magnification factor and the resistance of any valve will depend not only upon its structure, but also the constants of the circuit in which it is used. Before, however, going into this matter it will perhaps be well to discuss somewhat briefly the effect on the magnification and resistance by slight dimensional changes in the valve itself.

It will have been recognised that the magnification factor (K) and the resistance

(R) are extremely important factors in the operation of a three-electrode valve, and it is therefore necessary to know how these most important factors depend upon the structural dimensions of the valve.

The magnification of a valve is due to the screening effect of the grid, and therefore it must vary according to the number of turns in the grid, other factors remaining constant. It is to be noted, however, that the magnification does not increase in direct proportion to the number of turns, for if the number be doubled we find that the magnification is more than twice the original value.

Now it must be obvious that the thicker the grid wire the greater the screening effect for any given number of grid turns, and therefore the magnification will vary directly as the diameter of the grid wire.

Generally we may say that the nearer the grid is placed to the filament the greater will be the amplifying effect, but the further the anode is from the filament the higher the anode voltage required. This follows from the fact that the impedance increases as the distance filament to anode is increased.

The anode impedance furthermore depends on the size of the electrodes, and, within limits, is inversely proportional to the area of the anode. When, however, the anode is a cylinder an increase in its diameter will increase the distance filament to anode in the same ratio as the area of the anode is increased, and a gain can only be obtained by an increase in its length.

Now this opens up an interesting though extremely complex field, and we can therefore but deal with the subject in a more or less broad way, and merely outline how certain types of construction produce certain results.

In Fig. 6 we have drawn the anode current-grid volts characteristics for two different valves, A and B, but different only to the extent that A has less grid turns than B. In other respects the two valves are the same and the same anode and filament volts have been maintained for the two curves, namely 50 and 4 respectively. Now, first of all, we see that in the case of A (less turns in the grid) the anode current starts earlier than it does in the case of B, although the angle which the straight parts of the characteristics make with the base line, is the same as in the case of A.

If, however, we were to plot anode current against anode voltage at some definite grid voltage we should find the curves for the two valves to vary quite considerably, and as a matter of fact it would be found that the curve for valve A would be much steeper than that for valve B, thus indicating that the former has the lower impedance.

We are thus taught that altering the number of turns in the grid, other things remaining constant, does not materially alter the *shape* of the anode current-grid volts characteristics, but it does alter the position of the curve on the diagram, the

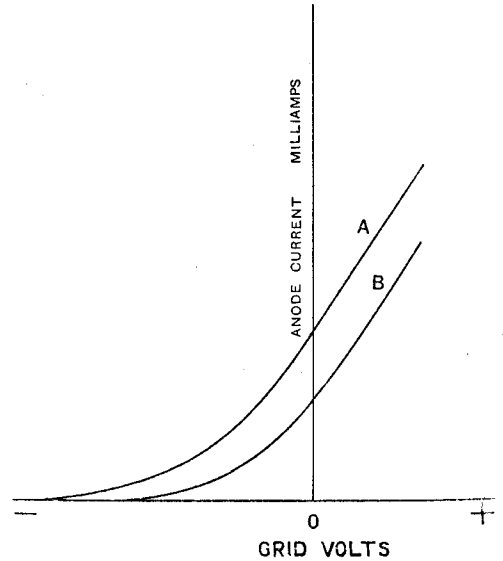

Fig. 6.

effect of less turns being to move the curve upwards and to the left. On the other hand the anode current anode volts curve is materially altered by altering the number of grid turns, the less the turns the steeper the curve.

The effect of this difference in grid turns can be roughly explained in the following diagrammatic way.

In Fig. 7A is shown the case of the valve A, that is the one with the lesser number of turns in the grid, and is meant to represent a section through the valve. The bottom line is the filament, the dots above it a section through the grid wires, and the top thin line is the anode. Now we may look upon each grid wire as being the centre of a circle whose radius indicates the grid

potential either + or -, and if this potential be negative, the circle will represent a region of repulsion to the electrons leaving the filament; the greater the grid potential the larger the radius of the circle. Now if we suppose the grid to be at a certain negative potential, in amount, as indicated

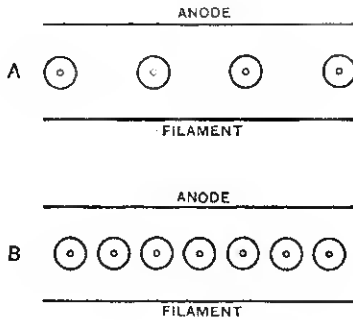

Figs. 7A and B.

by the circles of Fig. 7A, we see that there are still spaces through which the pull of the anode can act, and thus a certain number of electrons will be drawn through to the anode, although, due to its opposing force, none will reach the grid. Furthermore, the anode current will still be controlled by

the grid because by increasing or decreasing its potential, we increase or decrease the radius of our hypothetical circles, thus varying the space through which the anode pull can act. The case of the valve with the larger number of turns in the grid is indicated by Fig. 7B, where it is seen that for the same grid potential as before (the circles being the same diameter), only very few electrons can get through to the anode, and hence the anode current will be very small. It is further seen that a further slight increase in negative grid potential would put up a complete barrier between the filament and anode through which no electrons could penetrate, and thus the anode current would be zero. Fig. 7 also shows that in the close grid valve, the grid will have a greater control over the anode current than in the case of the open turns, in that less negative grid voltage is required to stop the anode current, and this means that the magnification factor of valve B is greater than that of valve A, for as we have already seen, the magnification factor is defined as that voltage which, if applied to the anode, produces the same change in anode current as does one volt on the grid, that is to say, it is the index of the relative effects on the anode current of grid and plate potentials.

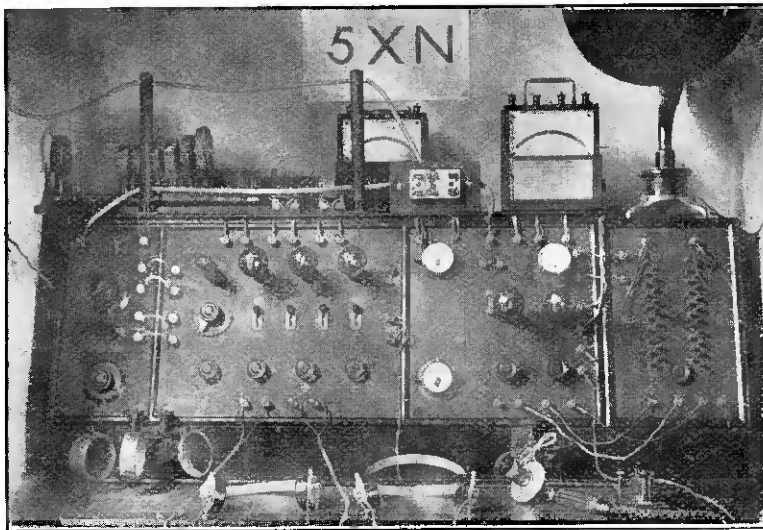

A neatly arranged transmitting and receiving outfit. The tuner and amplifying panel are standard Burndept equipment whilst the transmitting apparatus has been specially designed. A station so carefully set out is convenient to manipulate, and good results are obtainable by reason of the fact that tuning adjustments and peculiarities are constant and can be memorised. The location is Eltham, London, S.E.

“RESULTS.”

SOME CONSIDERATIONS ON THE DESIGN OF A RECEIVER.

By SYDNEY BURNS.

THERE was a time when a wireless enthusiast's claim to experimentalist status was readily established providing he displayed an aptitude for the rapid sketching of receiving circuits upon the back of old envelopes, and so long as those diagrams did not fail to satisfy two fundamental requirements—the inclusion of as many amplifying stages as the size of the envelope would permit and an intricate and awe-inspiring schematic arrangement.

More often than not, a query as to whether or no the diagram had been tried out by the draughtsman would have caused embarrassment to any but a wireless “fan,” and it goes without saying that very many of these arrangements of apparatus were quite

unsuited to moderately skilled manipulation—indeed, some of them were quite unworkable.

In this respect there has been a noticeable change during the last few months, and to be fashionable nowadays is to express unbounded confidence in those circuits which embody unusual arrangements of single valve or crystal and by means of which it is said to be practicable—at times—to receive telephony over great distances and telegraphy from almost anywhere. In this class may be placed those reflex, dual-amplification circuits about which we nowadays hear so much.

Now the level-headed fellow—surely the majority of wireless enthusiasts are such—

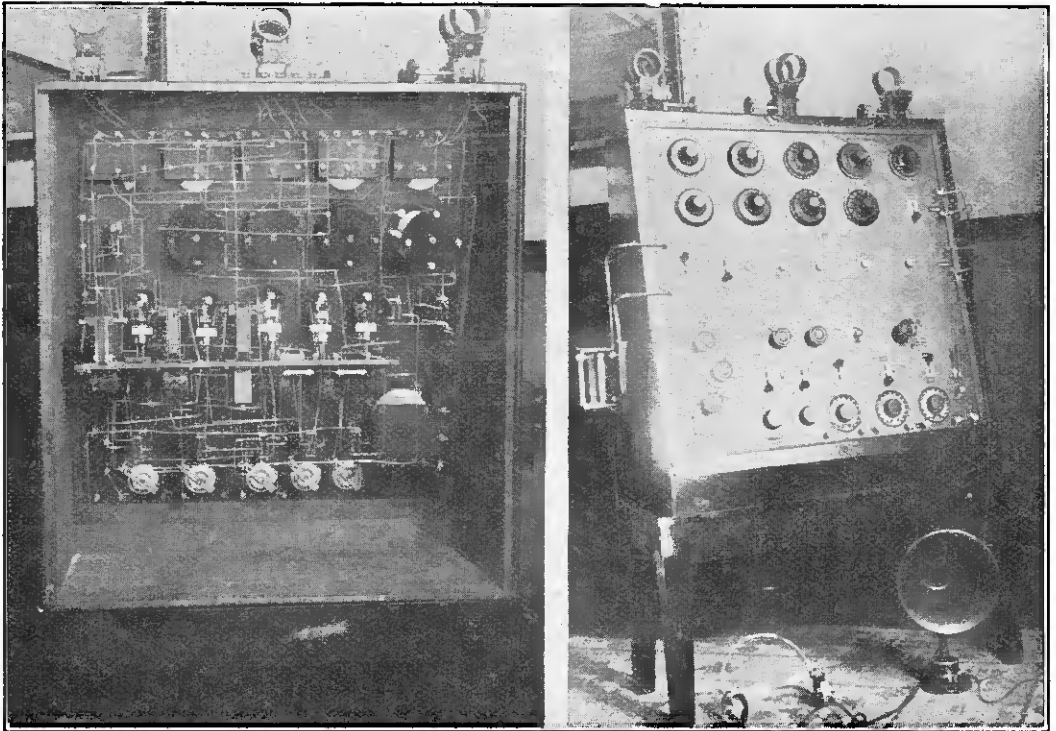

The five-valve receiver constructed by the author.

will have little patience with either of these extremes. He has no wish to possess a set so elaborate that it will only function when in more expert hands than his own, nor will he rest content with a receiver of so simple design that good reception can only result from a combination of circumstances little short of miraculous, to say nothing of the possible necessity of a re-radiating aerial in the immediate vicinity of his own. What the average enthusiast does require, however, are uniformly good results—*selectivity, reliability, and loud signal strength*—and these results must be attainable with a screened or partially screened aerial

being located within a mile of **GCC** (Cullercoats) is well placed for such work—but he hopes he is not jeopardising his licence when he says that most of the time allotted by him to wireless work is spent in receiving British and Continental telephony. This is hardly likely to be an unique experience and it would therefore appear to be wise to construct a set which, whatever else it may be capable of doing, will receive British Broadcast Company's programmes satisfactorily.

Sometimes the experimenter's set is not a thing of beauty. It may be constructed upon the so-called "unit" system, which

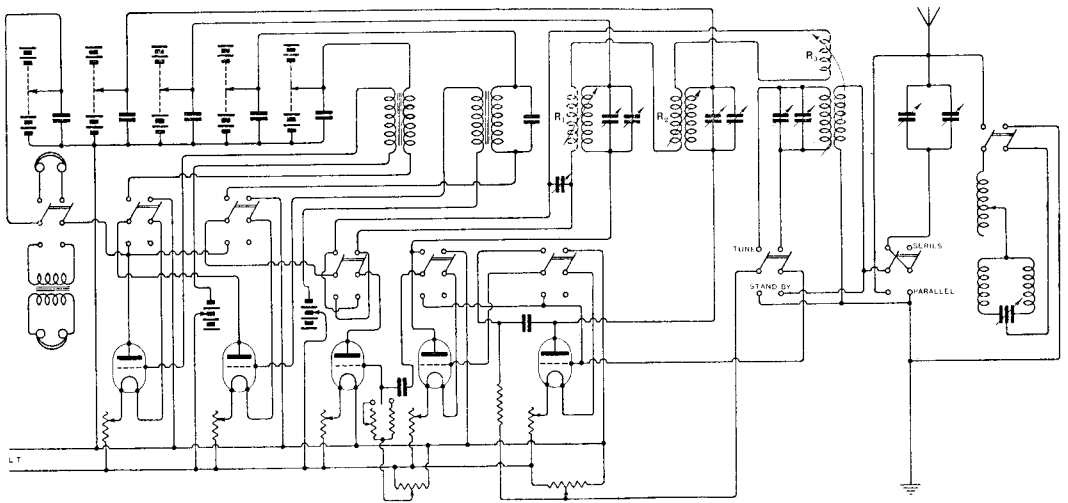

Circuit of the author's five-valve set. Switches provide for a variety of circuit arrangements.

since it is safe to say that seventy-five per cent of the privately-owned aerial equipment in this country bears little resemblance to those designs which grace the covers of various wireless magazines.

There are two faults to which the experimenter is peculiarly susceptible—insincerity and selfishness. His work may, and often does, provide a never-ending store of intellectual entertainment, but he is insincere if, on that account, he belittles the enjoyment and relaxation which broadcast telephony brings to him. The writer is experimenting with rejector circuits—and

means it occupies unnecessary space, and it can seldom be put into commission except by its owner. Now there is pleasure to be derived from arranging and connecting the equipment under the mystified gaze of the uninitiated onlooker, but there are others to be considered, and the writer has often felt there is a tinge of selfishness in not having the set so arranged that it can be "turned on" by others of the household who have been instructed in the tuning process. Therefore it is recommended that the set should be self-contained and preferably good-looking.

SOME USEFUL COMPONENTS.

A Filament Resistance.

A new filament resistance of good design is shown in the accompanying photograph. It is built up from moulded parts and has a good clean finish.

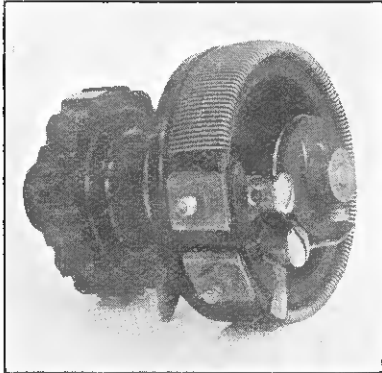

(Courtesy Gaston E. Marbaix.)

Filament resistance with vernier.

It is simple in construction, being assembled from a minimum number of components.

Provision is made for attaching it to panels of various thicknesses, whilst a vernier is provided so that the resistance can be used with soft valves where the filament current is likely to be critical.

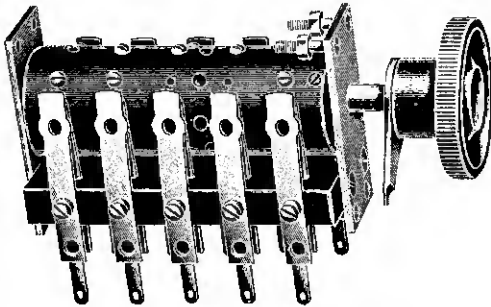

(Courtesy Sterling Telephone & Electric Co., Ltd.)

Adjustable barrel switch.

Multi Contact Switches.

When it is desired to alter the circuit arrangement of a valve receiving set, it is necessary to use a switch having a large number of contacts, and care must be taken to ensure that no losses occur owing to the manner in which the leads are brought together.

The barrel type of switch is probably the most useful for the purpose, for it is possible to adapt

its operation according to the purpose for which it is required.

It is possible, for instance, to remove the screws which operate the switch blades and insert them so that various combinations of contacts are provided.

Condenser or Variometer Dial.

Ebonite and metal dials are quite familiar to us for the adjustment of condensers and variometers, though these have, of course, a dull appearance when compared with the one shown, which has a white ivory scale.

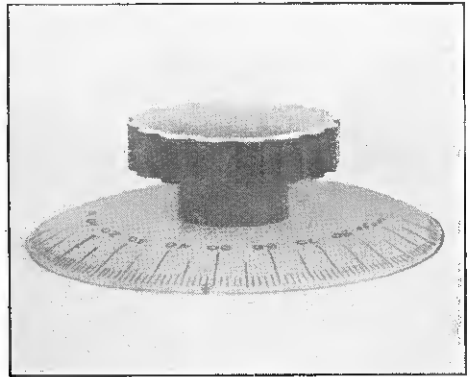

(Courtesy Gaston E. Marbaix.)

White ivory scale.

It has a very good appearance when mounted on an ebonite panel, and the engraving is easier to read than when in the more usual form of white figures on a black ebonite ground.

This dial has a hard shiny surface and retains its clean white surface.

Variable Grid Leak.

The design of a variable grid leak presents many difficulties. A leak must to some extent be capable of calibration and remain of constant resistance value in operation. From the section it can be seen that a brass stem advances into an enlarged portion of the ebonite tube. The hollow in the



(Courtesy Bretwood.)

Section of variable grid leak.

tube contains a plastic non-drying resistance material and the area of contact is increased as the stem is screwed home.

A UNIVERSAL RECEIVER.

The three-valve receiver is the best of sets for experimental reception. In this short article an experimenter describes the instrument which he has evolved after several years' work with various three-valve arrangements. The tuning unit is dealt with below and the valve equipment will be described in a subsequent issue.

By S. J. HEX.

MANY amateurs wish to build a really useful and efficient receiver for general reception, and it is the intention of the writer to give in this article a few tips on the construction of such a set. The set herein described is a three-valve receiver, embodying one H.F. amplifier, valve detector and one L.F. amplifier. This combination is considered ideal for the experimenter on account of the simple way in which one high frequency valve can be efficiently operated.

The tuner and amplifier are built as separate units and are contained in Mark III boxes which were obtained cheaply ex disposal board. Loose coupled tuning is utilised up to 1,800 metres and an ordinary single circuit on wavelengths above this up to 30,000 metres. The two cylindrical ebonite coils seen in the centre of the underside of the tuner panel are the short wave aerial tuning inductance and closed circuit inductance respectively. The aerial inductance

is $2\frac{1}{2}$ ins. diameter and is wound with No. 24 double silk-covered wire. Tappings are taken off at the 25th, 35th, 45th, 55th, 70th, 90th, 115th, 170th, and 200th turns. This coil is tuned by a 0.001 mfd. condenser

which can be connected either in series or parallel by means of the small switch shown between the two condensers. This switch is a converted Dewar type. The thin blades were taken out and the back cut off at the base. Two angle pieces were fitted and four "U" shaped contacts soldered to 4 B.A. screws which are then screwed into the ebonite base. This makes an efficient and inexpensive switch suitable for all radio frequency work.* The closed circuit consists of a

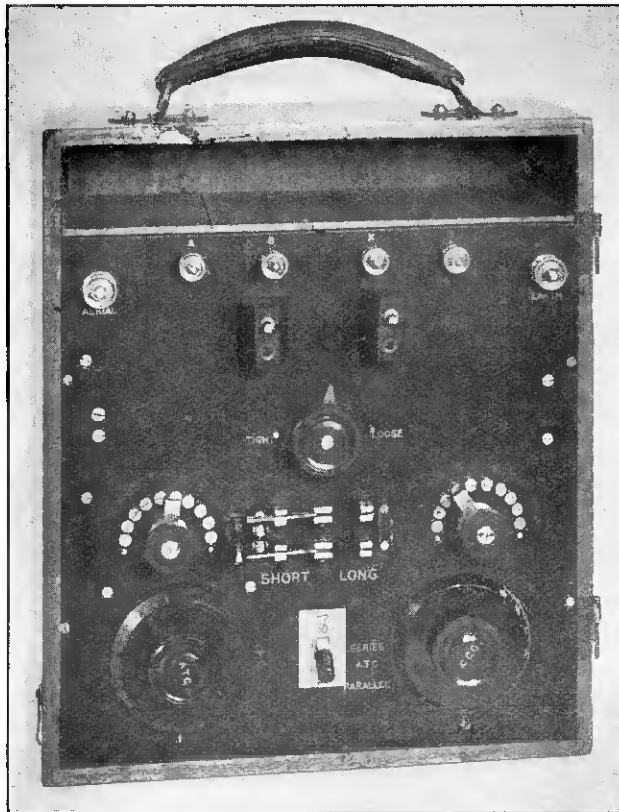

The tuner unit.

former $3\frac{1}{2}$ ins. in diameter wound with No. 24 D.S.C., tappings being taken off at the 20th, 30th, 40th, 47th, 55th,

* See *The Wireless World and Radio Review*, p. 200, May 19th, 1923, for further details of this switch, by E. E. Bramall.

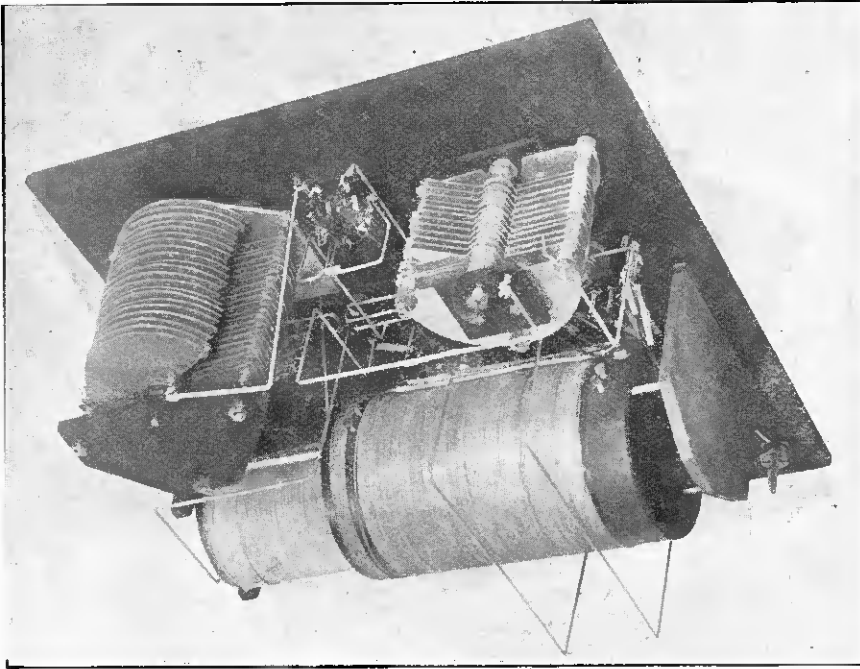

View of the underside of the tuner. The change-over switch, built from a Dewar switch movement, seen near the front edge, is of particular interest. It is easily made up, takes very little space, and is useful for switching H.F. circuits.

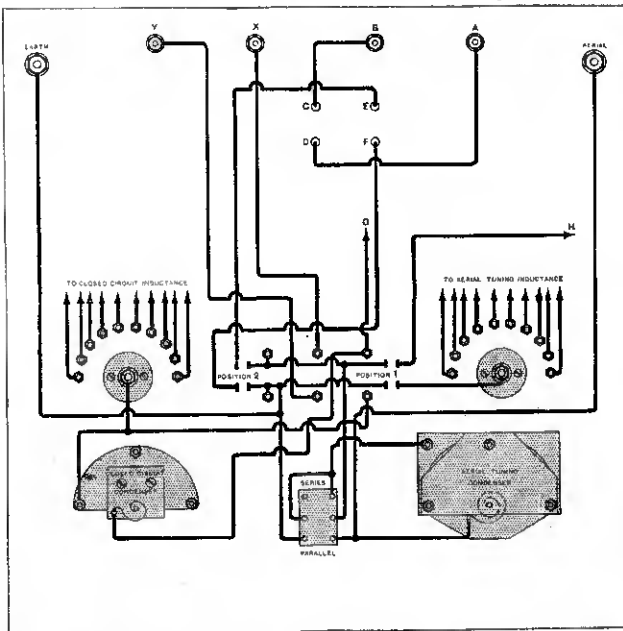

Connections of tuner unit. C and D, front and back connections of moving reaction coil holder. E and F, front and back connections of fixed coil holder. G and H represent respectively the start of closed circuit inductance and start of aerial tuning inductance.

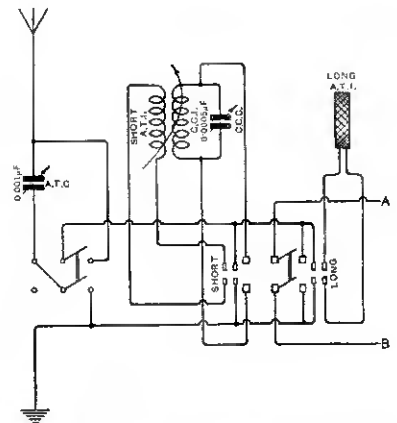

Circuit diagram of connections showing the action of the switches for changing over from short to long wave tuning.

65th, 80th, 110th, 145th and 170th turns. This coil is tuned by a 0.0005 mfd. condenser placed in parallel. The tappings are connected to the switch studs by means of Litzendraht wire which by reason of its

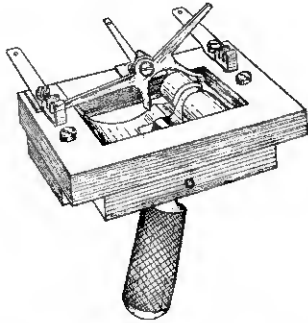

An adapted "Dewar" switch for use in high frequency circuits. Another arm with pair of contacts is fitted on the near side.

flexibility is very durable. Some little trouble may be experienced in soldering this wire but if each strand be carefully cleaned and a short piece of say No. 38 wire wound round the bunch, the soldering operation becomes simple, using a trace of "Fluxite" and a not over-heated iron.

(To be concluded.)

The secondary coil slides over the primary on two glass or brass rods which are supported by ebonite pillars at one end and a piece of wood at the other, and the coupling is controlled by the knob seen in centre of the panel. The knob actuates an arm to the end of which is attached a link piece. The latter is connected to the end of the secondary coil and pulls the coil backwards and forwards on the rods and so provides the necessary change in the degree of coupling. To enable the secondary coil to slide along the rods, suitable guide pins are necessary and these were made by fitting a pair of 5 B.A. screws at each end of the former and spacing them about 1/16 in. more than the diameter of the rods.

Changing over to long waves arranges a coil holder in circuit and completely disconnects the short wave inductances and closed circuit condenser. The same aerial condenser however remains and by which the long wave plug-in coils are tuned. The connections for this switch can be easily followed out in the circuit diagram. Reaction for long waves may be obtained by plugging suitable coils in the holder seen to the right of the aerial coil holder. This is pivotted and rotates through 180 degs. to give the necessary coupling. An alternative method of generation is adopted in the amplifier and will be described later.

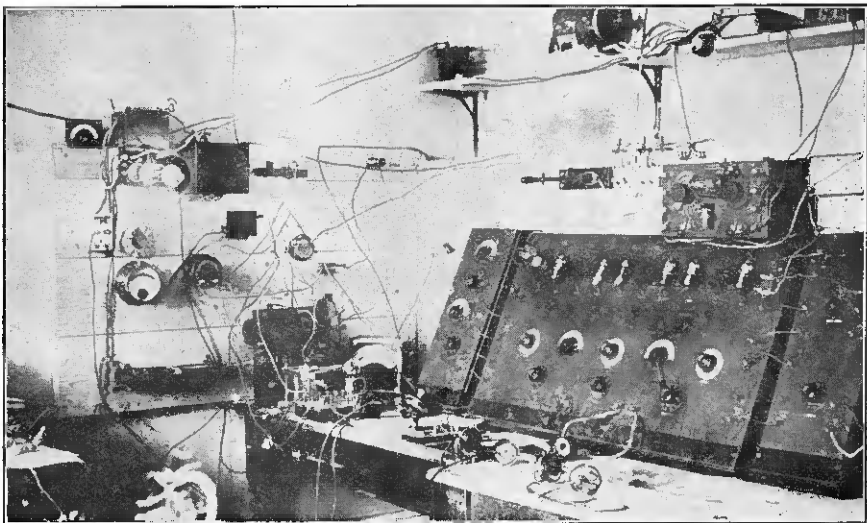

The transmitting and receiving apparatus at 2 JP, operated by Mr. M. C. Ellison and located in Yorkshire.

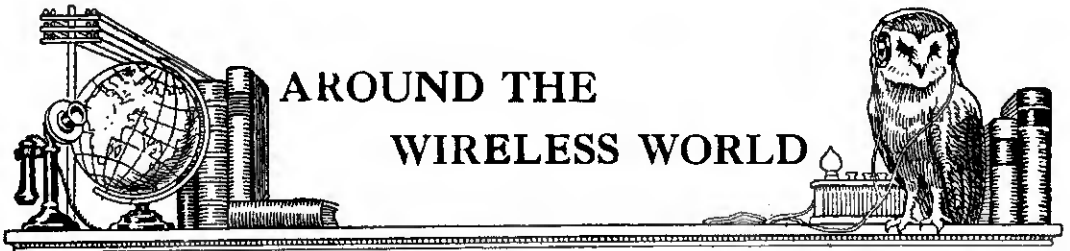

AROUND THE WIRELESS WORLD

As the result of a vote, the York Education Committee has ruled out a scheme permitting schools to install wireless sets for educational purposes. It is consoling to note that the majority against consisted only of one.

* * *
With the prospect of a relay broadcasting station at an early date, wireless licences are being issued in Edinburgh at the rate of over a hundred a week.

* * *
The Irish Dail has accepted the interim report of the Committee on Broadcasting in the Irish Free State. The report advocates vigorous national control of the new service.

Another Transmitting Record ?

An amateur transmission over 9,000 miles is claimed in a letter received by Mr. S. K. Lewer (6 LJ) from American 1 SN, who states that his signals have been heard by Z4 AA, in New Zealand. 1 SN employed four 5-watt valves.

Low Wavelength Amateur Transmissions.

An opportunity of receiving signals on between 40 and 50 metres is afforded by French 8 EB, owned by M. Aimé Clayeux, of Moulins (Allier). A series of tests on the above wavelength has been

arranged by 8 EB, the times of transmission being as follows:—Wednesdays, 8 to 8.15 p.m.; Saturdays, 7 to 7.15 p.m., 8 to 8.15 p.m., 10 to 10.15 p.m. Reports of reception of these signals by British amateurs will be welcomed and may be addressed to M. Clayeux, c/o the office of this Journal.

Proposed High-Power Broadcasting Station.

We understand that the B.B.C. contemplates the erection of a high-power broadcasting station in the vicinity of London, to operate on a wavelength of 1,600 metres. Preliminary experiments are to be conducted at Chelmsford.

It is understood that the object of the projected station would be to cover all areas in the country now inadequately served.

Permission has been granted by the Postmaster-General for the establishment of such a station for experimental purposes only, and before a permanent licence were issued the Government would require to be satisfied that no interference would take place with the official services.

New Relay Stations.

The B.B.C. announces the following call signs for new relay stations to be erected in the near future:—Plymouth, 5 PY; Edinburgh, 2 EH; Leeds, 2 LS; Liverpool, 6 LV; and Hull, 2 HU.

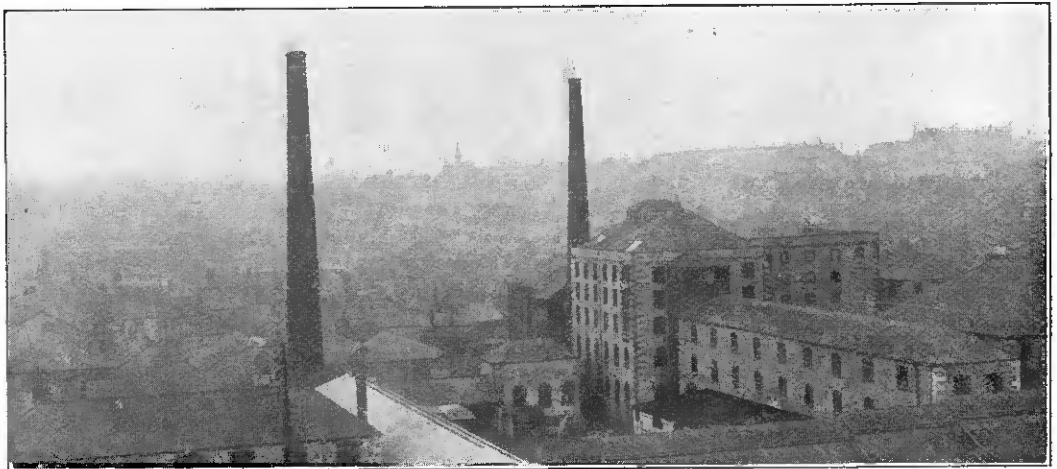

This somewhat uninspiring view depicts the site of the Plymouth relay broadcasting station, now in course of erection. The two disused smoke stacks, which are situated at the highest part of the town, will form excellent "masts."

Transatlantic Reception on 100 Metres.

An interesting log of his activities in the early hours of February 10th has been forwarded to us by Mr. E. J. Pearcey (2 JU), of Fulham, who employed a two-valve receiver (0-v-1), and confined himself to reception on 100 to 120 metres wavelength. We append extracts from the log.

- 3.40 a.m. NKF (pure C.W.) wkg. 8 XBH on 112 metres. 8 XBH replied. Strength good in both cases.
- 3.45 a.m. 1 XAR wkg. G 5 KO. Good strength.
- 3.50 a.m. 1 AJA clg. CQ. Rather weak.
- 4.0 a.m. 8 XAP wkg. G 2 KF.
- 4.24 a.m. 1 XAR heterodyned 9 XW. 9 XW called 8 XK, announcing special test. C 2 BG clg. CQ. Good strength.
- 4.30 a.m. U 3 EH wkg. PCII, announcing he was Harry Densham, Collingswood, N.J.
- 4.51 a.m. U 3 OT wkg. N PA 9.
- 5.22 a.m. U 3 OT wkg. G 2 OD, saying he was using 200 watts input; antenna current $2\frac{1}{2}$ amps.
- 5.33 a.m. U 1 XAR wkg. N PCTT.
- 6.7 a.m. U 1 XM clg. F 8 AB. Fair strength.

While pressure on our space precludes the insertion of Mr. Pearcey's log in full, the above affords an excellent indication of what is being done nightly by amateur transmitters who are quite ready to sacrifice sleep in order to "get across."

Luxembourg 1 JW.

That 1 JW has been very active of late is proved by the large number of reports we have received concerning his transmissions. The owner is Mr. Jean Wolff, of 67, Avenue Baumbusch, B.7, Luxembourg. Many readers also report reception of signals from the station of the Radio Club of Luxembourg, also an active transmitter.

A San Francisco Amateur.

9 AN, near San Francisco, California, has recently been heard by Mr. F. R. W. Stratford, of Dovercourt, Essex, and our correspondent asks whether any other British amateur has been similarly successful. It may be remembered that 9 AN was the most distant station to be heard during the Transatlantic Tests of 1922.

Radio Stations for Greenland.

The Dansk Radio Company has been given a contract for the erection of four commercial wireless stations in Greenland. Three of these stations will operate on C.W., the fourth being equipped with a spark transmitter for local traffic. In addition one transmitter is to be capable of communicating with Iceland, or, under favourable conditions, with the Faroe Islands and Europe.

A Burglary.

Messrs. Hambling, Clapp & Co., Ltd., of 11, Agar Street, Strand, London, W.C.2, regret that owing to a recent burglary on their premises, some delay has taken place in the execution of orders. Every effort is being made, however, to meet customers' requirements as early as possible.

Wanted—Reports of Reception.

Reports on their transmissions are welcomed by the following: 5 SW, C. Bedford, Turton Hall, Gildersome, near Leeds. 2 XG, A. E. Turville, 108, Abingdon Street, Northampton. 2 XG would also be glad to get into communication with any transmitting or receiving amateur who would be willing to co-operate in tests on 180-200 metres. The power used is 10 watts.

Broadcasting.

REGULAR PROGRAMMES ARE BROADCAST FROM THE FOLLOWING EUROPEAN STATIONS:—

GREAT BRITAIN.

ABERDEEN 2 BD, 495 metres; BIRMINGHAM 5 IT, 475 metres; GLASGOW 5 SC, 420 metres; NEWCASTLE 2 NO, 400 metres; BOURNEMOUTH 6 BM, 385 metres; MANCHESTER 2 ZY, 375 metres; LONDON 2 LO, 365 metres; CARDIFF 5 WA, 353 metres; SHEFFIELD (Relay from 2 LO), 303 metres. Mondays, Wednesdays, and Fridays, 1 p.m. to 2 p.m. (2 LO only) Regular daily programmes, 3.30 to 4.30 p.m., 5 to 10.30 p.m. Sundays, 3 to 5 p.m., 8.30 to 10.30 p.m.

FRANCE.

PARIS (Eiffel Tower), FL, 2,600 metres. Daily, 6.40 to 7 a.m. Weather Forecasts; 10.50 a.m. (Thursday and Friday), 11.15 to 11.30 a.m., Time Signal and Weather Forecast; 12.0 noon, Live-stock prices; 3.40 p.m. (Saturday excepted); Financial report, 5.30 p.m. (Saturday excepted) Bourse Closing Prices; 6.10 p.m., Concert or Address; 7 p.m., Weather Forecast; 7.20 p.m. (Sunday) Concert and Address; 10.10 p.m., General Weather Forecast.

PARIS (Compagnie Francaise de Radiophonie Emissions "Radiola"), SFR, 1,780 metres. Daily, 12.30 p.m., Cotton Oil and Caf. Prices, News, Concert; 1.45 p.m., First Bourse Report; 4.30 p.m., Bourse Closing Prices; 4.45 p.m., Concert; 5.45 p.m., News and Racing Results; 8.30 to 9 p.m., News; 9 p.m., Concert; 10 p.m. to 10.45 p.m., Radio Dance Music.

ECOLE SUPERIEURE des Postes et Télégraphes, 450 metres. 9 p.m. (Sunday, Wednesday, Thursday, Friday and Saturday), Talk on Literature, Dramatic and Musical Selections. 8.15 p.m. to 9.25 p.m. (Tuesday), Morse Practice, English Lesson, Lecture and Concert.

LYONS, YN, 3,100 metres. Daily, 9.45 a.m. to 10.15 a.m., Gramophone Records.

NICE, 460 metres. 11 a.m., 5 p.m. to 6 p.m., 9 p.m. to 10 p.m. Concert and News.

BELGIUM.

BRUSSELS, BAV, 1,100 metres. At 1 p.m. and 5.30 p.m., Meteorological Forecast; 9 p.m. (Tuesday), Concert.

BRUSSELS ("Radio Electrique"), 410 metres. Daily, 5 to 6 p.m., 8.30 p.m. to 9.30 p.m., Concert.

HOLLAND.

THE HAGUE, PCGG, 1,070 metres. 3 to 5 p.m. (Sunday), 8.40 to 10.40 p.m. (Monday and Thursday), Concerts.

THE HAGUE (Heussen Laboratory), PCUU, 1,050 metres. 9.40 to 10.40 a.m. (Sunday), Concert; 8.40 to 9.40 p.m., Concert; 7.45 to 10 p.m. (Thursday), Concert.

THE HAGUE (Velthuisen), PCKK, 1,050 metres, 8.40 to 9.40 p.m. (Friday), Concert.

HILVERSUM, 1,050 metres. 8.10 to 10.10 p.m. (Sunday), Concert and News.

IJMUIDEN (Middelraad), PCMM, 1,050 metres. Saturday, 8.10 to 9.40 p.m., Concert.

AMSTERDAM, PA 5, 1,050 metres (Irregular). 7.40 to 9.10 p.m., Concert.

AMSTERDAM (Van Diaz), PCFF, 2,200 metres, 8 a.m. and 4 p.m., Share Market Report, Exchange Rates and News.

DENMARK.

LYNGBY, OXE, 2,400 metres. 7.30 to 8.45 p.m., Concert (Sunday excepted).

GERMANY.

BERLIN (Koenigswusterhausen), LP., 4,000 metres. (Sunday), 10 to 11 a.m., Music and Lecture; 2,700 metres, 11 a.m. to 12 noon, Music and Lecture. Daily, 4,000 metres, 6 to 7 a.m., Music and Speech; 11.30 a.m. to 12.30 p.m., Music and Speech; 4 to 4.30 p.m., News.

EBERSWALDE, 2,930 metres. Daily, 12 to 1 p.m., Address and Concert; 7 to 8.30 p.m., Address and Concert; (Thursday and Saturday), 7 to 8 p.m., Concert.

BERLIN (Vox Haus), 400 metres. 8 to 9 p.m. Concert.

CZECHO-SLOVAKIA.

PRAGUE, PRG, 1,800 metres. 7 a.m., 11 a.m. and 3 p.m., Meteorological Bulletin and News; 4,500 metres, 9 a.m., 2 p.m., and 9 p.m., Concert.

KBEL (near Prague), 1,000 metres. Daily, 6.20 p.m., Concert, Meteorological Report and News.

SWITZERLAND.

GENEVA, HB 1 (Radio Club de Genève). Temporarily suspended. LAUSANNE, HB 2, 1,100 metres (Monday and Wednesday), 4 p.m., Concert; 1,000 metres (Friday and Saturday), Concert.

SPAIN.

MADRID, 1,650, 2,200 metres (Irregular). 12 to 1 p.m., Tests. MADRID, PTT, 400 to 700 metres. 4 to 5 p.m., Tests.

ITALY.

ROME, IOD, 3,200 metres. Weekdays 11 a.m. Gramophone Records.

Radio and Esperanto.

An extension in the use of Esperanto in connection with broadcasting has been a significant feature of the last few months. Quite recently addresses in Esperanto have been broadcast from the B.B.C. stations in London, Birmingham, Newcastle and Aberdeen, and on January 31st half-an-hour's programme in Esperanto was transmitted from the Bournemouth station. On the same evening an

Esperanto talk was given at the Prague broadcasting station by Prof. A. Pitlik. Numerous lectures and concerts in this international language have recently been broadcast from Moscow.

Transmitting Achievements in Holland.

Mr. H. J. Jesse, Junr., of Leiden, Holland, claims to have worked with 15 American and two Canadian amateurs, in addition to 88 Europeans.

The Radio Society of Great Britain.

TRANSMITTER AND RELAY SECTION.

Calibration Waves from 6 XX.

The calibration waves recently transmitted from 6 XX were sent, as arranged, every night except one. The signals of diminishing strength which it was proposed to send out were, however, not transmitted. It was found difficult to alter the strength of the signals in the manner desired with the apparatus at present installed at 6 XX.

The Franco-British Tests on 200 Metres.

The following is a continuation of the list in our last issue detailing the French reception of the British amateur transmissions during November and December last.

December 3rd.

2 CXL Boulogne.
2 DF Thibie.
2 DJ Reims.
2 DR Boulogne, Lyon, Orleans, Parc Saint-Maur, Reims.
2 FG Lyon.
2 FQ Boulogne, Lyon, Orleans, Paris, Reims.
2 GZ Parc Saint-Maur.
2 IN Boulogne, Lyon, Moulins, Orleans, Parc Saint-Maur, Reims.
2 IP Moulins.
2 JD Boulogne.
2 MG Reims.
2 NM Boulogne, Lyon, Paris, Thibie.
2 NO Alger.
2 NR Le Bourget.
2 OD Boulogne, Moulins, Paris, Reims.
2 ON Boulogne, Paris, Reims.
2 OW Parc Saint-Maur.
2 RS Boulogne.
2 SN Le Bourget.
2 WJ Boulogne, Orleans, Thibie.
2 ZK Lyon.
5 CH Le Bourget.
5 CI Lyon.
5 CO Lyon.
5 DN Boulogne, Le Bourget, Orleans, Parc Saint-Maur, Paris, Reims, Thibie.
5 FM Reims.
5 HI Boulogne, Moulins, Orleans, Reims.
5 HN Le Bourget.
5 KD Lyon.
5 KO Alger, Le Bourget, Orleans, Paris, Reims.
5 NN Alger, Boulogne, Parc Saint-Maur.
2 NO Paris.
5 QV Thibie.
5 SH Le Bourget.
5 SI Lyon, Reims.
5 SZ Boulogne, Lyon, Moulins, Orleans, Parc Saint-Maur, Paris, Reims.
5 US Moulins, Orleans, Parc Saint-Maur, Reims.
5 WU Parc Saint-Maur.
5 YI Orleans, Reims, Thibie.
5 YO Paris.
6 RY Reims.
6 TM Orleans.

December 5th.

2 CW Reims.
2 DR Orleans, Reims.
2 FQ Alger, Le Bourget, Moulins, Paris, Reims.
2 MO Parc Saint-Maur.
2 NM Le Bourget, Moulins, Paris.
2 OD Parc Saint-Maur, Paris.

2 RS Alger, Moulins, Reims.
2 VO Thibie.
2 VU Moulins.
2 WE Moulins.
2 WJ Le Bourget, Moulins, Orleans, Reims, Thibie.
2 ZF Parc Saint-Maur.
5 DN Le Bourget, Moulins, Orleans, Parc Saint-Maur, Paris, Reims, Thibie.
5 GJ Moulins, Orleans.
5 KD Arcachon.
5 KO Alger, Parc Saint-Maur, Paris.
5 NC Le Bourget.
5 NH Orleans.
5 NV Paris.
5 OZ Le Bourget.
5 PS Reims.
5 QU Parc Saint-Maur.
5 QV Le Bourget, Moulins, Orleans, Reims, Thibie.
5 SI Reims.
5 SZ Arcachon, Moulins, Orleans, Parc Saint-Maur, Paris, Reims.
5 TA Le Bourget.
5 YA Paris.
5 YI Orleans, Parc Saint-Maur, Paris, Reims, Thibie.
6 RY Paris, Reims, Thibie.
9 SO Le Bourget.

December 7th.

2 CW Parc Saint-Maur, Paris.
2 DR Parc Saint-Maur, Paris, Reims.
2 KO Paris.
2 KV Parc Saint-Maur.
2 NM Paris.
2 OD Le Bourget, Parc Saint-Maur, Paris.
2 VO Arcachon.
2 WJ Le Bourget, Parc Saint-Maur, Reims.
5 CH Le Bourget.
5 CM Le Bourget.
5 DN Arcachon.
5 DX Le Bourget.
5 KD Paris.
5 NN Alger.
5 PS Reims.
5 QV Alger, Arcachon, Reims.
5 SZ Arcachon, Reims.
5 YI Alger, Arcachon, Parc Saint-Maur Paris, Reims.
5 YV Parc Saint-Maur.
5 ZM Paris.

December 9th.

2 CW Paris, Reims.
2 DR Arcachon, Le Bourget, Orleans, Paris, Reims, Thibie.
2 DX Le Bourget.
2 FQ Reims, Thibie.

2 LZ Alger.
2 NN Paris.
2 OD Paris.
2 UG Reims.
2 VQ Reims.
2 WJ Le Bourget, Orleans, Paris, Reims, Thibie.
5 CH Le Bourget.
5 CM Le Bourget.
5 CS Le Bourget.
5 DB Paris.
5 DM Orleans, Reims.
5 DO Le Bourget.
5 DX Le Bourget.
5 DN Le Bourget.
5 FS Le Bourget.
5 GJ Alger, Le Bourget, Orleans, Reims, Thibie.
5 KD Arcachon, Orleans.
5 KO Arcachon, Le Bourget, Orleans, Paris, Reims, Thibie.
5 ON Paris.
5 QV Alger, Le Bourget, Orleans, Paris, Reims, Thibie.
5 SH Le Bourget.
5 SZ Reims.
5 YI Orleans, Parc Saint-Maur, Paris, Reims, Thibie.
5 YM Paris.
6 AH Orleans.
6 EA Reims.

Undated Receptions.

Conerre.—**2 CP**, **2 NM**, **2 OI**, **2 YQ**, **2 VS**, **2 CW**, **2 IN**, **2 DR**, **2 OD**, **2 JO**, **2 OF**, **2 JF**, **2 CM**, **2 TF**, **2 ON**, **2 HS**, **2 FN**, **2 FQ**, **2 MY**, **2 BR**, **2 WJ**, **2 WK**, **2 IJ**, **2 MM**, **2 NA**, **5 PU**, **5 KO**, **5 DN**, **5 SZ**, **5 MO**, **5 YI**, **5 BV**, **5 FS**, **5 HI**, **5 NN**, **5 PS**, **5 BU**, **5 QV**, **5 SI**, **5 GJ**, **5 MS**.

Marseille (stations received before and during the Tests).—**2 OD**, **2 SZ**, **2 KP**, **2 XR**, **2 UF**, **2 FL**, **6 NI**, **5 KO**, **2 NM**, **2 FN**, **5 PU**, **2 OJ**, **2 JF**, **2 OM**, **5 BV**, **2 WC**, **5 FS**, **2 CN**, **2 VS**, **2 FQ**.

Thiais (stations heard communicating with each other during the tests).—**2 BX**, **2 CW**, **2 DD**, **2 DF**, **2 DR**, **2 ED**, **2 FQ**, **2 HH**, **2 IH**, **2 IN**, **2 JF**, **2 JO**, **2 KF**, **2 KJ**, **2 KO**, **2 KW**, **2 LZ**, **2 MM**, **2 NB**, **2 NM**, **2 NR**, **2 NT**, **2 OD**, **2 PC**, **2 RH**, **2 UA**, **2 VA**, **2 VO**, **2 VS**, **2 WJ**, **2 YQ**, **2 ZG**, **2 CX**, **5 BV**, **5 DB**, **5 DN**, **5 DO**, **5 FQ**, **5 GJ**, **5 HA**, **5 HI**, **5 IZ**, **5 JX**, **5 KD**, **5 KO**, **5 KT**, **5 KZ**, **5 MO**, **5 NN**, **5 ON**, **5 QV**, **5 SI**, **5 SZ**, **5 US**, **5 WR**, **5 WX**, **5 YI**, **5 YM**.

AN INSTRUMENT FRAME.

ON BUILDING A FRAMEWORK TO REPLACE THE USUAL WOODEN BOX.

By F. H. HAYNES.

THE idea of supporting instrument panels on a framework of angle metal is not a new one, though it has not become standard practice in this country. Large transmitters, as with other large electrical gear, are usually built into metal framework, and this form of construction is equally useful when the building of an elaborate receiver is undertaken. It is not, perhaps, warranted in the case of a single valve or crystal set, but where a number of valves are to be made use of and a variety of tuning and amplifying apparatus is to be housed the frame is to be recommended.

A frame built of angle metal is no more difficult to construct than a well-finished wooden box, and makes a much more substantial and durable job. If desired, component parts can be supported on platforms within the frame, although with small receiving instruments it is advisable to adhere to the usual practice in which all apparatus is completely carried by the front panel.

The accompanying illustration shows a frame composed of angle brass, and used to enclose a four-valve full-range receiver. It measures 10 ins. in width by 15 ins. in height, and is 8 ins. deep. The valves and entire component parts are totally enclosed and the operating dials appear on the front panel, which is attached to the outer face of the frame. The angle brass used is

$\frac{1}{2}$ in. wide on its outer faces, and is about $\frac{1}{8}$ in. in thickness. It is hard rolled metal, and bright and clean with sharp edges when purchased. The total cost of the brass used for the frame shown did not exceed five shillings.

In building the frame, the front and back rectangles, which are identical, are made up first. The corners are carefully mitred and held together by corner brackets sawn from the same angle brass used for the frame and each about $\frac{7}{8}$ in. in length. These are fitted tightly into the corners, and held by No. 5 B.A. screws by making clearance holes through the corner brackets and tapping screw holes into the sides of the frame. Every care must be taken to ensure that the corners are fitted together closely and rigidly and that the sides are precisely at right angles. The two rectangles thus made have short projecting corner pieces which face inwards and these are used for

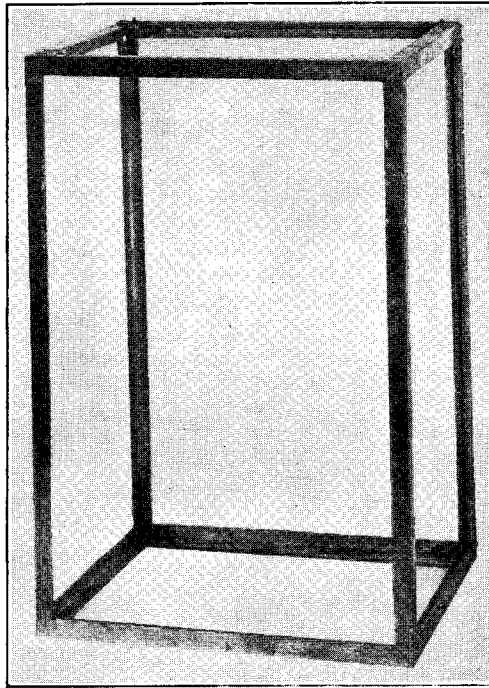

A frame constructed from angle brass. The front face carries the ebonite panel.

ended pieces of angle metal which represent the depth of the frame. Four countersunk screws in each cross piece secure the whole frame together. The screw heads are, this time, on the outside, being tapped into the corner pieces, and in order that the heads may not show afterwards it is advisable to leave them slightly raised. With everything screwed securely together and the frame pressed carefully into shape, the corners in turn are treated with killed salts (zinc

chloride), heated in the Bunsen flame and hard solder freely melted in. Excess can be shaken or wiped off with a cloth dipped in soldering solution, though it is necessary to see that the solder runs completely into the crevices of the corners and around the screws. The heads and projecting portions of the screws on the outer faces can be filed away with the excess of solder, and the brass work cleaned up with emery or carborundum cloth.

A good finish can be obtained by painting

the frame with "dead black," which is a solution used for blacking camera fittings, and in which the solvent is amyl acetate. Alternatively, it may be passed for bronzing to a firm handling this style of work.

If corner pieces were available with recessed ends to carry the strip angle metal, the building of these frames to any dimensions would be rendered very simple, as it would only be necessary to saw off lengths of angle metal and square up the ends.

INVENTIONS AND NOVEL IDEAS.

Valves.

A step in the evacuation of an electric discharge device having a filament coated with alkaline earth oxides consists in establishing a space discharge between the filament and other electrodes of the device in an atmosphere of carbon monoxide sufficient to fill the bulb with a blue haze, after which the carbon monoxide is removed

oxides, and a grid 12, and anode 13, are connected by means of a tube 14, with a pumping apparatus. A battery 15, supplies the filament heating current, and a battery 16 establishes a voltage between the filament and the grid and anode. The pumping apparatus consists of a boiler 17, containing mercury, which is heated by means of the resistance element 18, to which current is

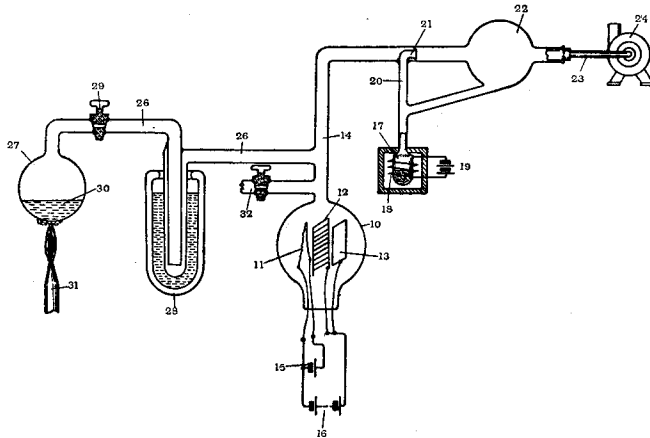

Fig. 1.

and the evacuation of the device completed. It is said that the process described below* increases the emissivity of a filament coated with alkaline earth oxides.

Referring to Fig. 1, a valve 10, having a filament 11, coated with alkaline earth

supplied from a battery 19. A conduit 20 leads from the boiler 17, and terminates in a nozzle 21, which directs a stream of mercury vapour toward the air-cooled condenser bulb 22, which is connected by the conduit 23 to an oil pump 24. By means of this apparatus the bulb may be exhausted in the well-known manner.

* British Patent No. 207,161, by the Western Electric Co., Ltd.

In order to supply carbon monoxide to the valve 10, a conduit 26, leads to a vessel 27, through the liquid air trap 28. In the vessel 27 is provided a supply of sodium formate, and a gas flame 31 is provided for heating the vessel.

After the gas has been removed from the valve 10, the tap 29 is opened, and carbon monoxide is led through the liquid air trap to the valve 10. The liquid air trap serves to prevent any water vapour or carbon dioxide which may be generated, from reaching the valve 10. A space discharge is now established between the filament and anode and grid, and the carbon monoxide is maintained at a sufficient density to keep the valve filled with a blue haze from the discharge between the electrodes. After a time the tap 29 is closed, and the valve exhausted. It is claimed that one half hour's treatment as outlined above has been found to materially increase the activity of a coated filament.

Improvements in Valve Circuits.

In order to secure faithful reproduction of speech, it is frequently necessary to apply a negative voltage to the grid of a valve.

Referring to Fig. 2, a resistance D is connected between the negative terminal of the anode battery and the filament.* The anode current therefore passes through the resistance, and there is a voltage drop

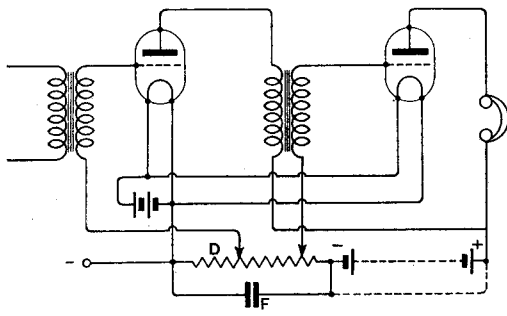

Fig. 2.

across it. Therefore if the return wires of the grid circuits are connected to points on the resistance, the grids have a negative potential with respect to the filament. The resistance is shunted by a condenser F, whose impedance for the frequency at which the amplifier works is small in comparison with that of the resistance.

* British Patent 209,184, by P. W. Willans.

Valve Amplifiers.

An interesting valve amplifier is described by Gesellschaft für Drahtlose Telegraphie,* and the principle will be understood by referring to Fig. 3. Valve B is connected to

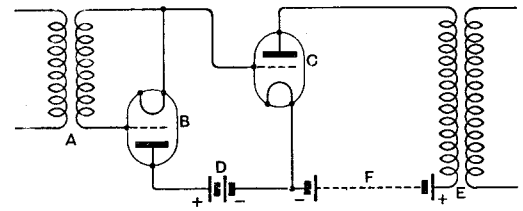

Fig. 3.

the grid circuit of valve C. The incoming signals are applied by the transformer A to the grid-filament circuit of valve B, the filament of which is joined to the grid of valve C, while its anode is connected through the anode battery to the filament of valve C. The anode circuit of valve C is completed through the primary winding of transformer E and the battery F.

The incoming oscillations cause variations of potential on the grid of the valve B, whose resistance therefore varies, and therefore the voltage supplied by the battery D to the grid of valve C varies in rhythm with the oscillations.

The principle may be applied as shown in Fig. 4, where the two main valves are coupled back to back, and two control valves, the filament of each being connected directly to the grid of one of the main valves, while

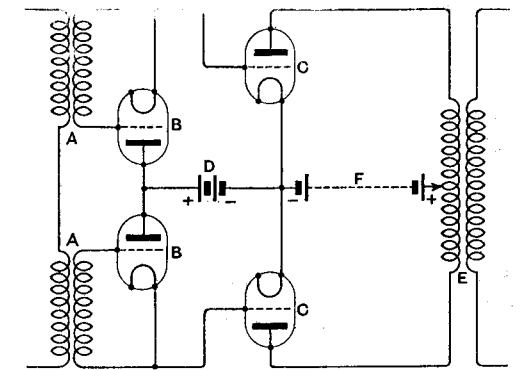

Fig. 4.

their anodes are both connected to a source of current which is connected to the filaments of the main valves.

W. J.

* British Patent 189,112.

CORRESPONDENCE.

Transmitting Records.

To the Editor of THE WIRELESS WORLD AND RADIO REVIEW.

SIR,—I was very pleased to note in your columns of to-day that our brother brass pounder, **5 KO** claims a record in DX working, and I would like to be one of the first to congratulate him through your columns.

At the same time I would like to be so bold as to state that the Committee of the Radio Transmitters' Society holds the record up to date for Transatlantic two-way working, one member (**2 OD**) having worked 19 Canadians and Americans, whilst two others (**2 KF** and **2 SH**) have worked 14 and 10 respectively, and I myself have worked seven.

The furthest I have worked are **3 AU** and **3 YO**, the latter being Lafayette University, Pennsylvania, but I believe one member at least has worked two ninth district amateurs and one eighth.

GERALD MARCUSE (**2 MN**).

Radio Transmitters' Society.

Caterham, Surrey.

Low Capacity Inductance Coils.

To the Editor of THE WIRELESS WORLD AND RADIO REVIEW.

SIR.—I was very interested in the article by F. H. Haynes in the issue of February 13th, on Low Capacity Inductances, and venture to offer one or two hints.

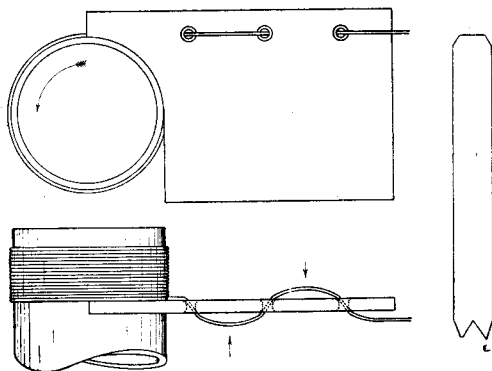

Wire is threaded through a piece of hard fibre as it is fed on to the rotating former. The steel centre marker on the right is a useful device for setting out a row of evenly spaced holes.

(1). For winding in tension bare wire, upon a cylindrical former, taking out all kinks at the same time, and (2) spacing large numbers of centre dots for drilling ebonite strips.

The accompanying rough sketches show the methods I propose and should make my meaning clear.

Seven Kings.

V. HOAD.

Transatlantic Two-Way Working.

To the Editor of THE WIRELESS WORLD AND RADIO REVIEW.

SIR,—The weather conditions having become more favourable for "DX" working, I have on several mornings been in touch with the other side and on one occasion by telephony (not accidental!)

From recent observations it appears that when the barometer is low on this side conditions are certainly favourable for transatlantic working, and I believe the same thing applies over there.

1 BDI (Mr. E. E. Handy, U. of M. Orono, Maine), seems to be a very efficient station, and on Sunday morning, February 10th, received my telephony on what he termed a "cracker box," receiver. He was able to understand from my remarks that I was taking his signals on three valves and getting him well.

A later attempt at pushing a message over by "fone" was only partially successful, owing to QRM on the American side, but he received the address of the message and following this heard me say "did you get the message O.K." He was very "bucked" and is writing for confirmation at once. My aerial current was 1 ampere only.

I effected communication later with **1 CMP**, **3 OT** and **8 XAP**, all reporting my signals very good. **3 OT** was using a single valve receiver. **1 BDI** reported my C.W. as "all over the room on loud speaker!" The experiments are continuing, and I hope to get a really good message across very soon, without repetition, on "Fone."

I have worked with twelve U.S.A. and two Canadians to date.

Merton, S.W.19.

J. A. PARTRIDGE.
G2 KF.

Radio and Orchestral Works.

To the Editor of THE WIRELESS WORLD AND RADIO REVIEW.

SIR,—It may interest your correspondent, Mr. H. E. Adshead, that his suggestion in your issue of January 23rd, re two loud speakers to reproduce radio orchestral items, has been in use in my station for some time.

I use a Brown H.R. loud speaker for the low tones and a Magnavox for the high tones. A 0.001 microfarad condenser is in shunt with the Brown; this subdues, somewhat, the notes of a high frequency. A 500 ohm choke is across the Magnavox, which was chosen for the high tones, because of its tightly stretched diaphragm, and therefore high natural frequency of vibration. The Brown was selected for the low tones because of its moving reed and coned diaphragm, which together have a low natural frequency.

F. SIEGER.

London, W.8.



WITH THE SOCIETIES

Particulars of Membership of any Society can be obtained on application to the Secretary. Societies marked with an asterisk are affiliated to the Radio Society of Great Britain.

Wimbledon Radio Society.*

On February 8th an absorbing lecture was delivered by Mr. J. A. Partridge (2KF), who entertained his audience with an account of his successful efforts to bridge the Atlantic by wireless. After narrating the first attempts at Transatlantic two-way working, carried out by the American Radio Relay League and the Wireless Society of London in February, 1921, Mr. Partridge recounted the much more successful tests of 1922.

With regard to the power required to work across the Atlantic, the lecturer stated that, in his experience, 10 watts was useless, and that for absolute reliability, 50 watts was the minimum that could be employed. Mr. Partridge had himself applied for and been granted a 100-watt permit. Whilst working with French 8AB, he accidentally decreased his wavelength to 100 metres, whereupon 8AB reported great increase of signal strength. 8AB then got into touch with the American station 1MO, informing him that 2KF would call him. As a result 1MO heard 2KF's transmissions—weak but constant.

A constructional evening was held at the next meeting on Friday, February 15th. The cabinets for the Society's 4-valve receiver having been delivered further progress was made with the assembling of the receiver. A discussion was also held on "Short Wavelength Work."

The Hon. Sec., C. G. Stokes, of 6, Worple Avenue, Wimbledon, S.W.19, will welcome enquiries concerning the Society's activities from enthusiasts and prospective members in the Wimbledon district.

Kingston and District Radio Society.*

Mr. R. M. H. Lucy (2ZR), of Messrs. S. G. Brown, Ltd., gave a very interesting chat on "Telephones" before the members of the Society on February 4th. Mr. Lucy opened his discourse by explaining that the greatest difficulty which confronted telephone manufacturers was the prevention of breakdowns in the windings of high resistance telephones, an accident generally erroneously attributed to a "burnout," i.e., the actual fusing of the wire due to carrying an excessive current. In many instances, however, it has been found on carefully unwinding the bobbins (some of which contain as many as 13,000 turns of wire) that the fine wire has been attacked by a peculiar form of corrosion, the exact nature of which it has not yet been possible to define, but is indirectly ascribed to rust on the magnet bars. Very elaborate precautions, both in design and during manufacture, are therefore taken to exclude moisture in order to prevent rust. At one time it was thought to be due to perspiration from the winders' hands, but a trial extending over a long period, during which time certain winders wore rubber gloves,

disproved this theory. A series of mysterious breakdowns were also finally discovered to be due to the high temperature of the workshops which caused the delicate wire to expand and, being tightly wound on the bobbins, was unable to withstand the strain of contraction when subjected to a cooler atmosphere. Much care has also to be exercised in the choice of a suitable wax with which to impregnate the coils for often the purest contains sufficient acid to subsequently prove detrimental to the wire.

The lecturer went into the subject of loud speakers and dealt at some length with the acoustic properties of various horns. Although not a commercial proposition he remarked that a horn cast in lead about half an inch in thickness was absolutely free from resonance, and a great deal of experimental work is still being conducted in this direction with a view to finding a light material having similar advantages. Agitating the air by means of wires electrically heated shortly occurred to him, however, and the results proved to be remarkable good.

Hon. Sec., R. J. W. Lankester, Wanderings Farm House, Kingston-on-Thames.

The Radio Society of Highgate.*

The hundredth meeting of the Society was held on Friday, February 7th, when a most interesting lecture was given by Mr. G. G. Blake, F.Inst.P., M.I.E.E., on "The Modern View of Electricity and its Relation to Matter." Mr. Blake began by discussing in a simple manner the theory of relativity, and some analogies were given to convey some conception of the smallness of electrons. The constitution of solids, liquids and gases was dealt with, and a striking experiment was shown to illustrate the motion of the particles in a liquid. The uses of X-rays to study the constitution of molecules was very clearly explained by means of lantern slides and experiments, and the existence and properties of ultra-violet light were also demonstrated. Lantern slides and experiments were also shown illustrating the properties of waves and the action of the thermionic valve.

On February 15th a lecture on "Analogies" was given by Mr. E. S. Anderson. A simple electrical circuit was explained by means of a water cistern and its pipes. The properties of inductance, capacity and oscillatory circuits were also clearly demonstrated by means of mechanical and hydraulic analogies. An ingenious analogy was given to explain the flatness of tuning of waves radiated from an open aerial, and the modulation of a telephony carrier-wave was compared to the corrugations on a gramophone record disc.

Full particulars of the Society will be gladly supplied on application to the Hon. Sec., J. F. Stanley, B.Sc., A.C.G.I., 49, Cholmeley Park, Highgate, N.6.

Tottenham Wireless Society.*

On Wednesday, February 13th, Messrs. Clare, Haines and Vickery lectured on the Flewelling and other interesting circuits. Diagrams were shown and the lecturers carefully explained how to get the best results, their various practical tips being especially appreciated. In the discussion which followed other members gave the results of their experiences, thus contributing towards a most successful evening.

Hon. Sec., S. J. Glyde, 137, Winchelsea Road, Bruce Grove, Tottenham, N.17.

The West London Wireless and Experimental Association.*

A very instructive and interesting meeting was held on Tuesday, February 5th, when Mr. T. W. Hyne Jones read a paper entitled "A 1½ K.W. Ship's Transmitter." The lecturer illustrated his paper with diagrams drawn on the blackboard, and in the course of his remarks described most fully the theory of—(1) The spark oscillatory system. (2) The D.C. automatic starter and motor circuits, showing how the alternator field was excited. (3) The L.T.A.C. circuit showing protective gate switches, L.F.C.I. (choke), change-over switch and key, and transmitter primary connections. (4) H.T. and closed oscillatory circuits. (5) Aerial circuit, showing jigger secondary, A.T.I. ammeter and send and receive contacts.

The meeting held on February 12th was set aside for an experimental evening, and with the Instrument Steward, Mr. A. P. Dobson, officiating, several "hook ups" were carried out. Gentlemen desiring to join the Association should communicate with the Secretary, who will supply full information.

Club rooms, Acton and Chiswick Polytechnic, Bath Road, Chiswick.

Hon. Sec., Horace W. Cotton, 19, Bushey Road, Hayes, Middlesex.

Portsmouth Radio Society.*

On Wednesday, February 6th, members of the Society were present in force to hear a promised lecture by their past President, Mr. J. H. C. Harrold, M.I.R.E., whose subject was "The Wonders of the Ether." Instead of dealing with the technical side of wireless, Mr. Harrold spoke of everyday phenomena which were directly due to the presence of the ether.

The Society wish to call the attention of non-members who are just beginning wireless to a series of lectures being given by the Treasurer, Mr. W. Gall, who is specially catering for the needs of the absolute beginner.

Meetings are held every Wednesday at 7.45 p.m. at the Pile Memorial Rooms, Fratton Road, and all interested are cordially invited to attend.

Hon. Sec., A. G. Priest, 9, Peckham Street, Southsea.

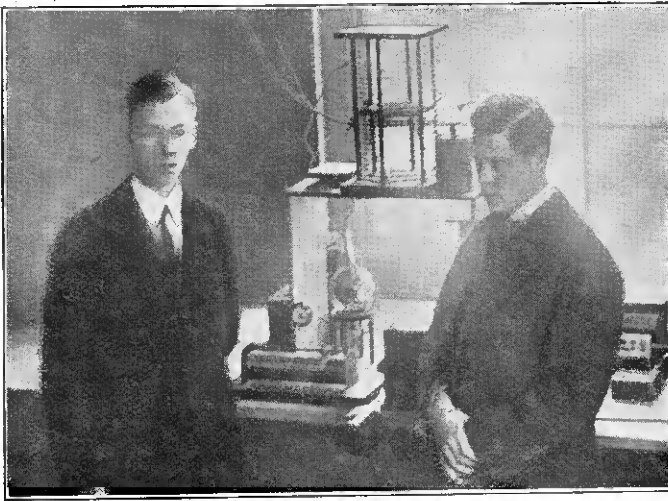

On Thursday, February 21st, H.R.H. the Prince of Wales visited Mill Hill School, and evinced great interest in the transmitting apparatus of Mr. C. W. Goyder (2 SZ) who has recently communicated with American and Canadian amateurs. In our photograph the Prince is seen conversing with Mr. Goyder.

Bristol and District Radio Society.

A lecture of absorbing interest was delivered on February 8th, by the President of the Society, Prof. A. M. Tyndall, D.Sc.

The subject of the lecture was "Oscillations" and the crowded audience was greatly interested, not only in the lecturer's remarks but in the experiments which served to illustrate the discourse.

In closing his remarks, Prof. Tyndall paid tribute to the work done by English scientists — especially mentioning Richardson—to whom we are in great part indebted for our present knowledge of wireless matters.

Hon. Sec., A. S. Harvey, 6, Woodleaze, Sea Mills, Shirehampton, Bristol.

Port Sunlight Radio Club.

The members of the Port Sunlight Radio Club, who possess an eight-valve receiving set, made special arrangements on Wednesday, February 6th, to hold an experimental dance. The music was provided by the Manchester Broadcasting Station, and transmitted to a series of loud speakers fixed in a central position in one of the halls of the Staff Training College at Port Sunlight. A most successful evening was spent by about a hundred members and friends.

At the conclusion of the dance music, Manchester sent "Greeting to the Port Sunlight Club and best wishes for the success of the radio dance you have arranged for this evening."

So successful was the experiment of "Wireless dancing" that the Committee of the Club have decided to arrange an open dance in one of the larger halls in Port Sunlight, having proved that the apparatus as fixed gave ample volume for even the biggest hall in the place.

North Middlesex Wireless Club.*

Every experimenter in the field of wireless communication encounters difficulties about which he desires to exchange views with his fellow enthusiasts or to seek advice from someone more expert than himself.

It was with a view to affording immediate help in such matters that the Committee of the North Middlesex Wireless Club decided to hold an informal meeting devoted to "Doubts and Difficulties."

This meeting, which was a thorough success, took place on February 6th last. A small committee of the Club's experts were formed to give advice and members were invited to ask questions.

There was no dearth of questions, which were ably dealt with by Messrs. Holton and Forbes, assisted by other members, and among points of discussion were the design of aerials, accumulator management, switching devices, transformer v. choke coupling in L.F. circuits, and the testing of ebonite.

Hon. Sec., H. A. Green, 100, Pellatt Grove, Wood Green, N.22.

The Barking and District Radio Society.

The Society continues to make good progress and the membership is increasing weekly. With the change of headquarters to the Station Hotel, much more suitable and comfortable accommodation has been arranged, there being seating accommodation for at least 750 members. With the installation of a 5-valve experimental panel much instructive work can be carried through, and with the arranged programme of a series of interesting lectures, it is hoped that considerable local support will be forthcoming.

Hon. Sec., M. C. Willett, 16, Monteaule Avenue, Barking.

FORTHCOMING EVENTS.

WEDNESDAY, FEBRUARY 27th.

- Radio Society of Great Britain.** At 6 p.m. (tea at 5.30). At the Institution of Electrical Engineers. "A Practical Demonstration of the Applications of the Cathode Ray Oscillograph." By Mr. N. V. Kipping.
- Edinburgh and District Radio Society.** At 8 p.m. At 117 George Street, Lecture: "The Human Ear." By Dr. H. Dryerre.
- Tottenham Wireless Society.** At 8 p.m. At 10, Bruce Grove. Lecture by Mr. F. H. Haynes (Assistant Editor of *The Wireless World and Radio Review*).
- Clapham Park Wireless and Scientific Society.** Testing night.
- Fulham Public Libraries.** At 8 p.m. At the Central Library, 598, Fulham Road. Lecture: "Wireless and Sound; and The Possibility of Television." By Prof. A. M. Low.

THURSDAY, FEBRUARY 28th.

- Hendon Radio Society.** At 8 p.m. At the Society Hut, Brent Works. Practical Evening. Subject, "Wavemeters and their Use."
- Salé and District Radio Society.** Lecture by a Visitor.
- Dewsbury and District Wireless Society.** Lecture: "The Armstrong Super-Heterodyne Circuit." By Mr. F. Dransfield.
- Institution of Electrical Engineers.** At 6 p.m. (Light Refreshments at 5.30.) Ordinary Meeting. Lecture: "The Design of Apparatus for the Protection of A.C. Circuits." By Mr. A. S. FitzGerald, Associate Members.

FRIDAY, FEBRUARY 29th.

- Brookley and District Radio Association.** At Gladstone Hall, New Cross Road. Lecturer from the South London League of Radio Societies.
- Sheffield and District Wireless Society.** At 7.30 p.m. At the Department of Applied Science, St. George's Square. Lecture: "Super-Regeneration." By Mr. R. Pritchett, B.Sc.

SATURDAY, MARCH 1st.

- Annual Conference of Affiliated Societies.**—At 2 p.m. At the Institution of Electrical Engineers, Savoy Place, Victoria Embankment, W.C.2.

MONDAY, MARCH 3rd.

- Ipswich and District Radio Society.** At 55, Foonereau Road. Lecture: "Tuned Anode." By Mr. J. R. Bird.
- Dulwich and District Wireless and Experimental Association.** Lecture and Demonstration: "The Neutrodyne Circuit." By Mr. L. M. Skinner.
- Salé and District Radio Society.** At 37, School Road. Fault Tracing Competition.
- Kingston and District Radio Society.** Lecture: "Development and Manufacture of Thermionic Valves." By the President, Captain S. R. Muldard, M.B.E., A.M.I.R.E.

WEDNESDAY, MARCH 5th.

- Institution of Electrical Engineers (Wireless Section).** At 6 p.m. (light refreshments at 5.30 p.m.) At Savoy Place, W.C.2. Lecture: "Development of the Bellini-Tosi System of Direction-Finding in the British Mercantile Marine." By Commander J. A. Slee, C.B.E., R.N.(Ret.), Member.

Questions & Answers

Solutions of Readers' Difficulties

1. All questions are answered through the post. A selection of those of general interest is published.
2. Not more than four questions may be sent in at any one time.
3. Every question should be accompanied by a postal order for 1/-, or 3/6 for four questions, and by a coupon taken from the current issue.
4. A free coupon appears in the first issue of each month, and if this is sent in together with coupons from the three previous issues, entitles the reader to have one question answered free of charge.

"B.M.W." (London, N.8) asks for a diagram of a four-valve receiver (1-V-2), using high frequency transformer coupling, and switches to control the number of valves in use.

The diagram is given in Fig. 1. A coupled circuit tuner is used to obtain better selectivity. When the first switch is thrown to the left, the first valve is switched out of circuit and the tuner is connected through to the detector valve. The remaining switches are connected in the note magnifier circuits in the usual way.

"M.J.M." (London, N.W.8), asks if it would be practicable to extend the telephone leads from his receiver in order that signals may be received in other rooms of the house.

The suggestion is quite practicable, provided that particular attention is paid to the insulation of the leads. Ordinary 5 amp. lighting flex will be quite satisfactory, and has the advantage of being wound non-inductively. The receiving apparatus should be placed as near as possible to the point where the lead-in enters the house.

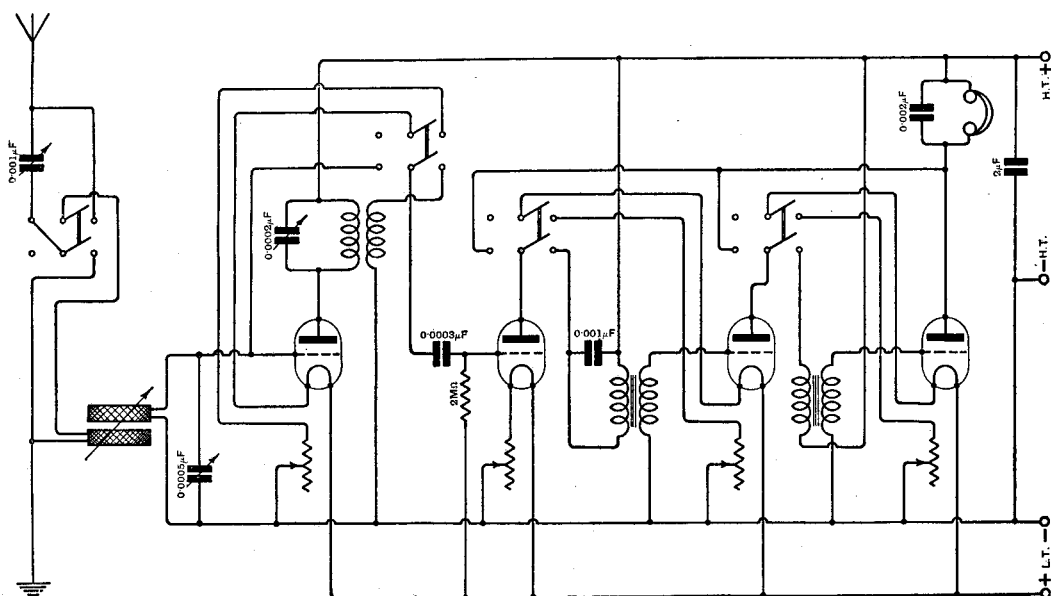

Fig. 1. "B.M.W." (London, N.8.) A four-valve receiver with 1 H.F., detector and 2 L.F. A high frequency transformer is used to couple the H.F. and detector valves.

"H.S.H." (Axbridge) asks for a diagram of a three-valve receiver (1-V-1) with switches to vary the number of valves in use.

The diagram is given in Fig. 2. A coupled aerial circuit is used, and the H.F. valve is coupled to the detector by the tuned anode method. A switch has been included to reverse the reaction coil connections when the H.F. valve is switched in or out of circuit.

H.F. amplifier, includes a tuned circuit which is coupled with the aerial circuit to obtain reaction effects. The H.F. oscillations in the tuned plate circuit are rectified by the crystal detector and passed on to the L.F. amplifier through the intervalve transformer. Care should be taken in adjusting the reaction coupling that the receiver is not allowed to oscillate violently or for a period longer than is absolutely necessary when first

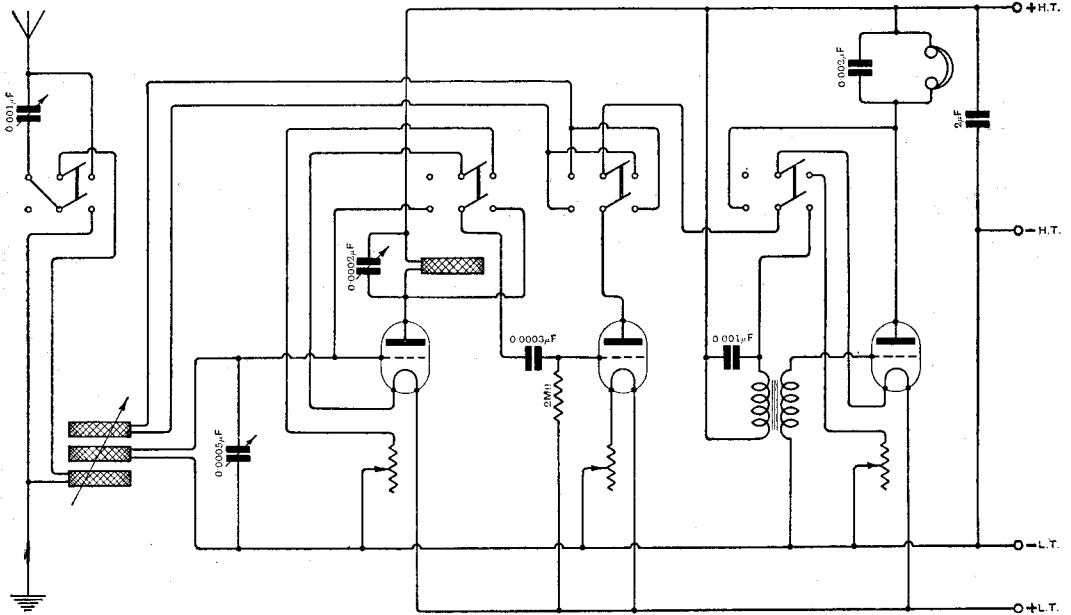

Fig. 2. "H.S.H." (Axbridge). A receiver with tuned anode H.F., detector and L.F.

"A.W." (North Berwick) asks for a circuit diagram of a simple two-valve and crystal receiver capable of receiving the B.B.C. transmissions on a standard P.M.G. aerial.

A suitable circuit is shown in Fig. 3. The plate circuit of the first valve, which functions as an

tuning in, otherwise interference may be caused with other receivers in the neighbourhood.

"V.G.P." (High Wycombe) asks whether it is necessary to take the lead-in from the exact centre of a "T" type aerial.

The lead-in should be taken from the electrical centre of the horizontal part of the aerial. This point does not necessarily coincide with the geometrical centre, when the aerial is erected in the proximity of houses and trees. The tapping should be taken from a point such that the natural wavelengths of each half of the aerial are equal. When a "T" type aerial is used for transmission, it will be found that the radiation is considerably affected by any movement of the tapping point.

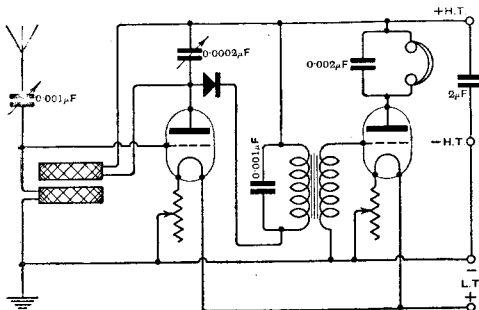

Fig. 3. "A.W." (North Berwick). A receiver with H.F., crystal detector, and note magnifier.

"N.W.E." (South Lancing) asks if it would be possible to use a single valve Flewelling receiver in conjunction with an outdoor aerial.

The radiation from a receiver of this type is liable to cause serious interference with other receiving stations, and we cannot therefore recommend its use with an outdoor aerial.