

# The Wireless World

THE  
PRACTICAL RADIO  
JOURNAL  
28<sup>th</sup> Year of Publication

No. 984.

THURSDAY, JULY 7TH, 1938.

VOL. XLIII. No. 1.

Proprietors : ILIFFE & SONS LTD.

Editor :  
HUGH S. POCOCK.

Editorial,  
Advertising and Publishing Offices :  
DORSET HOUSE, STAMFORD STREET,  
LONDON, S.E.1.

Telephone : Waterloo 3333 (50 lines).  
Telegrams : "Ethaworld, Sedist, London."

COVENTRY : 8-10, Corporation Street.  
Telegrams : Telephone :  
"Autocar, Coventry." 5210 Coventry.

BIRMINGHAM :  
Guildhall Buildings, Navigation Street, 2.  
Telegrams : Telephone :  
"Autopress, Birmingham." 2971 Midland (4 lines).

MANCHESTER : 260, Deansgate, 3.  
Telegrams : Telephone :  
"Iliffe, Manchester." Blackfriars 4412 (4 lines).

GLASGOW : 26B, Renfield Street, C.2.  
Telegrams : "Iliffe, Glasgow." Telephone : Central 4857.

PUBLISHED WEEKLY. ENTERED AS SECOND  
CLASS MATTER AT NEW YORK, N.Y.

Subscription Rates :  
Home, £1 1s. 8d. ; Canada, £1 1s. 8d. ; other  
countries, £1 3s. 10d. per annum.

*As many of the circuits and apparatus described in these  
pages are covered by patents, readers are advised, before  
making use of them, to satisfy themselves that they would  
not be infringing patents.*

## CONTENTS

	Page
Editorial Comment .. ..	1
The Acorn Valve .. ..	2
More about Magnetic Tuning .. ..	5
What is an Invention? .. ..	8
A "Ribbon" Pick-up .. ..	9
Unbiased .. ..	10
News of the Week .. ..	11
Slow-speed Discs .. ..	13
Television Topics — Magnetic Focusing .. ..	15
Readers' Problems .. ..	17
Random Radiations .. ..	18
Broadcast Programmes .. ..	18
Recent Inventions .. ..	20
Principal Broadcasting Stations .. ..	21

## EDITORIAL COMMENT

### B.B.C. Succession

#### Probability of No Appointment

SIR JOHN REITH has said farewell to the British Broadcasting Corporation, and whether or not his vacant chair is reoccupied by the time these comments appear does not alter the fact that the delay in deciding upon the succession is regrettable from many points of view.

We would have expected that the new appointment would have been made at the time that Sir John Reith's acceptance of his new post was announced.

It seems to us inconceivable that the departure of Reith to another office or some other eventuality which would have deprived the B.B.C. of his services should not have been provided for in advance and that at least Reith himself should have had the right to recommend, if not actually to appoint, a candidate of his own choice.

If no provision has been made to take over the reins from Sir John Reith then the only possible explanation seems to be that in an otherwise highly organised scheme a serious lapse has occurred.

During the period since the announcement of Sir John's departure rumour has appointed a series of persons to the post and we can picture the position which must exist at Broadcasting House with so many presumptive chiefs, each having his group of supporters. This division of the B.B.C. into camps can hardly fail to make the task of any man who eventually had to take over a far more difficult one than would have been the case if an early appointment had been made, leaving no time for speculation. Almost, it would seem to us, the delay must mean that the appointment will not fall to an individual within the existing organisation.

It is difficult to speculate on how

matters will work out, especially as the official answer may be made known at any time. Yet we would venture the suggestion that there may quite likely be no successor appointed to replace the irreplaceable Sir John Reith. Reith has for some years now tended to favour the appointment of controllers responsible for the various branches of B.B.C. activities. These appointments have relieved the chief of a great deal of detail and appear to have been a satisfactory way of apportioning both the work and the responsibility. A slight extension of this plan, increasing the responsibility of individual controllers still further and perhaps with the appointment of additional controllers if the need should arise, would be a solution which would do honour to Reith as a confirmation of a policy introduced by him and at the same time it would make the position of the Board of Governors, and especially of the Chairman of the Board, more effective. The Chairman of the Board would then become the spokesman and head of the Corporation, and his should certainly become a whole-time appointment.

Reith, we should remember, was head of the B.B.C. before the idea of a Board of Governors was propounded, and it was in order not to divest him of status when a Board was appointed that the post of Director-General was created. We believe that if Sir John Reith had not been already in "possession," so to speak, the Chairman and Board of Governors would have ruled over the B.B.C. without such an appointment being made at all.

Is it not logical, therefore, to suggest that a proper solution of the matter could now be found by confirming Reith's organisation in the matter of controllers and at the same time strengthening the position of the Board of Governors?

# The Acorn Valve

## ITS ADVANTAGES AND METHODS OF OPERATION AT ULTRA-HIGH FREQUENCIES

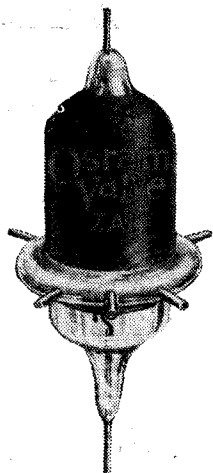

*THE various applications of the miniature Acorn valves, which have been designed especially for use on the ultra-high frequencies, and the circuits found most suitable for them, are discussed in this article by a member of the Technical Staff of the M.O. Valve Co.*

At frequencies above 50 Mc/s it has been found that the amplification obtainable from normal receiving type valves decreases rapidly, which is due in part to the time of flight of the electrons from the cathode to the various other electrodes being comparable to one cycle of the frequency of operation and in part to the high self-capacity and inductance of the valves.

The only satisfactory method of obtaining a reasonable stage gain at frequencies between 50 and 300 Mc/s is by means of the Acorn valve.

mains triode, the Marconi or Osram, H42, and the Acorn triode of this make are given for comparison purposes. It is interesting to note that the output, or anode-cathode capacity, of the Acorn is relatively very much smaller than the other capacities.

The triode valve will be considered first as it is the simpler type, and, being cheaper, is more likely to be popular at the present time. Its first and most obvious use is as a regenerative grid detector, to which super-regeneration may be added if desired.

Inductance is essential at the ultra-high frequencies, and the one used in the original experiments with the valves was made as shown in Fig. 2. Its construction provides a convenient way of mounting the coil.

It is a differential-type condenser, and connection is made to the two fixed vanes

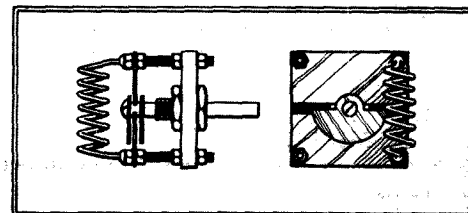
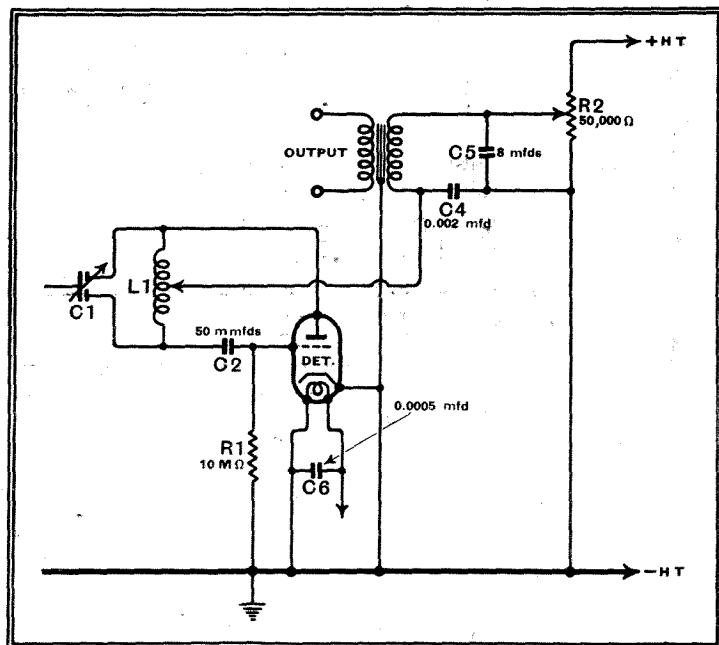

Fig. 2.—Details of split-stator condenser recommended for ultra-short-wave sets and showing also method of mounting the coil.



The circuit recommended is shown in Fig. 1, which as will be seen is similar to the well-known Hartley oscillator circuit, but regeneration is controlled by varying the anode voltage by means of the resistance R2. Increasing the anode voltage beyond the oscillation point causes super-regeneration to start, the frequency of which is partly

Fig. 1.—Circuit for an Acorn triode used as an ultra-short-wave regenerative grid detector.

These valves, which are now available both as triodes and as screen pentodes, have such a small physical size that their inter-electrode capacities are very low. Their small physical size also reduces the time of flight (electron transit time) until it is no longer troublesome, and the short leads to the elements permit the inductance of the circuit to be concentrated mainly in the tuning coil.

In Table 1 the respective capacities of a

determined by the grid leak and condenser R1, C2. This gives a smooth control and does not disturb the tuning of the circuit.

The size of the coils and number of turns required for various wavelengths are given in Table 2. The tapping on the coils should be near the centre, but the position for best operation will have to be found by experiment, since at very high frequencies the layout of the components, wiring, etc., greatly influence the operation of the circuit.

A tuning condenser having a very low

only, the rotor merely serving to vary the capacity. As no connection is made to the rotor, perfectly silent operation is ensured. In this condenser the rotor plates are semi-circular and have a radius of  $\frac{5}{8}$  in., which dimension will give a good indication of the size of the other parts required.

This condenser was used for the very high frequencies, but at 60 Mc/s or so more plates, or even a larger condenser of standard pattern, can be employed. The use of the smallest capacity to tune over the waveband to be covered is most desirable, as it enables the largest possible inductance to be employed.

### Receiver Assembly

The mechanical layout of this circuit is very important, and the components must be arranged so that short leads can be made. The Acorn valve lends itself very well to this, due to the manner in which the leads come out from the side of the glass pinch.

A two-valve circuit employing a separate quenching valve, which gives a higher efficiency than the self-quenching circuit of Fig. 1, is shown in Fig. 3. The

TABLE 2  
Ultra HF coils for use with HA1 and ZA1 valves.

1 metre ...	5 turns	$\frac{1}{4}$ in. diameter: turns spaced to occupy $\frac{1}{4}$ in.
2 metres ...	9 turns	$\frac{1}{4}$ in. diameter: turns spaced to occupy $\frac{1}{4}$ in.
3 metres ...	5 turns	$\frac{1}{4}$ in. diameter: turns spaced to occupy $\frac{1}{4}$ in.
5 metres ...	13 turns	$\frac{1}{4}$ in. diameter: turns spaced to occupy $\frac{1}{4}$ in.

All coils are wound with 16 S.W.G. copper wire and the tuning condenser is that shown in Fig. 2.

quenching valve does not need to be an Acorn, and a valve of the MHL4 class can be used. The coils L2, L3 are a standard quench oscillator unit.

The HA1 valve may be used as an

TABLE 1.

Comparison of Valve Capacities.

	H42	HA1
Grid-anode ...	3.0	1.4
Grid-cathode ...	2.6	1.0
Anode-cathode ...	5.3	0.6

oscillator, using the circuit shown in Fig. 4. Used in conjunction with an Acorn pentode, the ZA1, an ultra-high frequency superheterodyne, can be built. The coil L4 can be similar to those given in Table 2, though in the interests of frequency stability 30 per cent, fewer turns should be used, together with a larger condenser, which need not be of the special type previously described. Further details of the ultra-high-frequency receiver will be

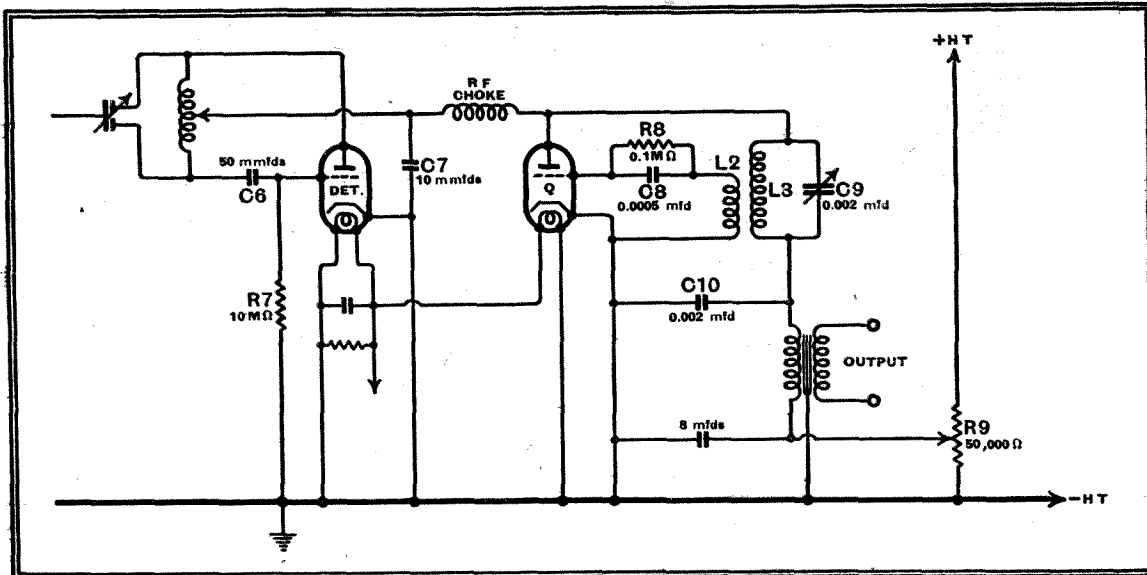

Fig. 3.—Super-regenerative circuit using an Acorn triode for the detector valve.

given when the Acorn pentode is discussed. The cathode tap should include one-quarter to one-half the total number of turns.

The Acorn triode is particularly suitable for use as an anode bend detector for valve voltmeter use, and, due to its high input impedance and small physical size, very little extra loading is put on the circuit at frequencies up to 20 Mc/s. A suitable circuit is given in Fig. 5. The resistance R12 biases the cathode to a

to produce the greatest output. A small transmitter made with the circuit of Fig. 7 gave good results at 300 Mc/s—i.e., one metre. It is built on a copper chassis which serves as a support for the lines; the anode line is earthed by the condenser shown, which is formed by interposing a piece of mica between the chassis and the copper support for the line. The length of each parallel line should be about 4 in., and final tuning is done by the condenser C 2 0. The aerial for local

of the triode; it enables real RF amplification to be obtained at frequencies above 50 Mc/s, where the normal receiving valve is likely to act more as an attenuator than as an amplifier. In appearance the pentode ZA1 is similar to the triode already described, but the

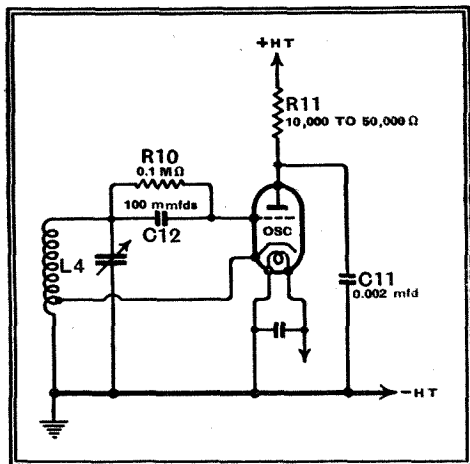

Fig. 4.—Typical oscillator circuit using an Acorn triode valve.

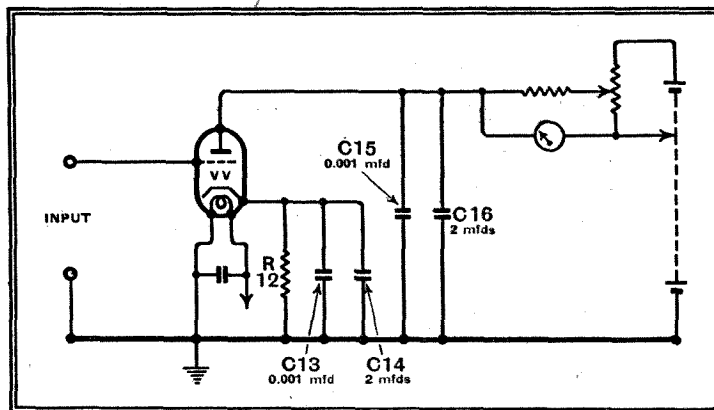

Fig. 5.—Using this circuit an Acorn triode can be employed as a valve voltmeter.

work may be a short vertical rod. Even higher efficiencies and greater frequency stability may be obtained by the use of concentric lines, each line being about 1/4 wavelength long, and the ratio between the diameters of the outer and inner conductors being three or four to one.

The Acorn pentode is a development anode and control grid connections are brought out at opposite ends of the glass bulb. This allows the valve to be mounted on a metal screen with the grid and anode circuits completely shielded from each other; the connections brought out through the glass pinch should all be maintained, as far as RF is concerned,

voltage  $E + 1$  volts, when  $E$  is the peak value of the input to the grid. When working at frequencies above 5 Mc/s, the mica condensers C13 and C15 are necessary, in addition to the larger paper condensers C14 and C16. It is suggested that the valve and mica condensers be mounted in a small shielding can with a flexible lead to the meter and batteries, so that the valve may be placed close to the circuit to be measured.

Fig. 6 shows a suitable circuit for a low-powered transmitter. Coils similar to those previously described may be used up to 150 Mc/s, but at higher frequencies the use of parallel or concentric tubes (Fig. 7) is recommended, as much higher efficiency and greater frequency stability is thereby obtained. The position of the tap on coil L5 in Fig. 6 should be varied

at earth potential when the valve is acting as an amplifier. A special type of mounting enables this to be done. The by-pass condensers, which are almost a part of the valve holder, form a very low inductance path from screen to cathode. Where other capacities are required, such as

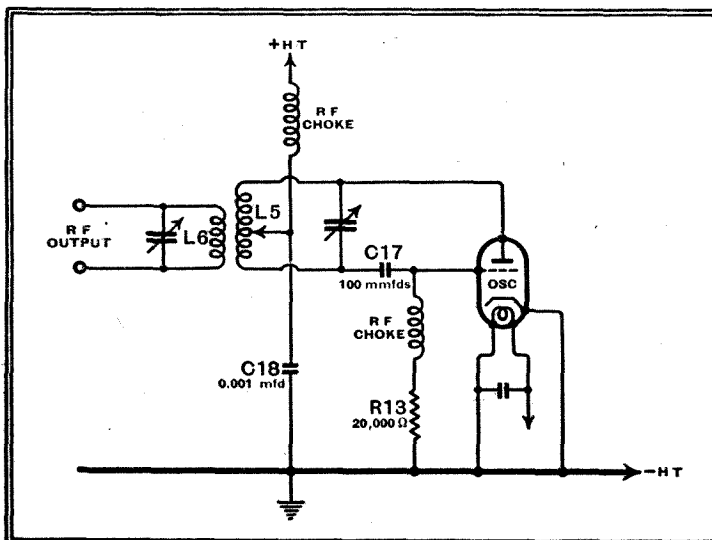
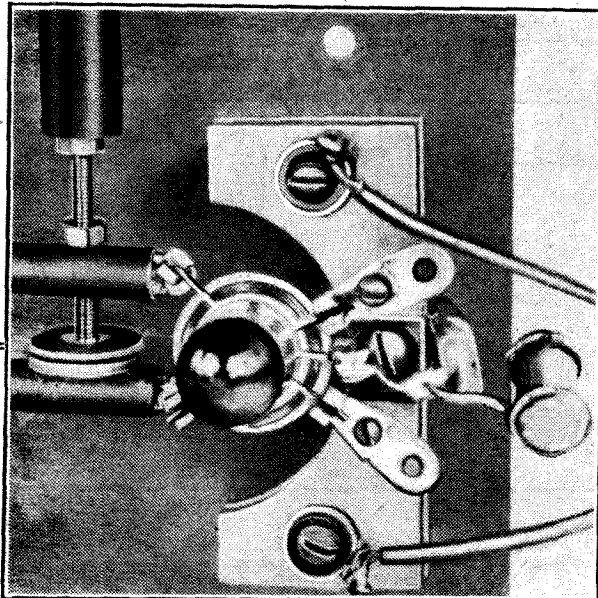

Fig. 6.—Circuit for a low-power ultra-short-wave transmitter.

across the cathode bias resistance, further copper and mica discs can be added. At the lower frequencies, between 25 and 50 Mc/s, where the Acorn valve has still an advantage over the normal pentode, this special type of holder is unnecessary, and small mica condensers mounted close to the valve give satisfactory results.



Method adopted for mounting the valve in the "long-lines" transmitter of Fig. 7. The disc-type variable condenser is C20 while on the right of the valve-holder are C19 and R14.

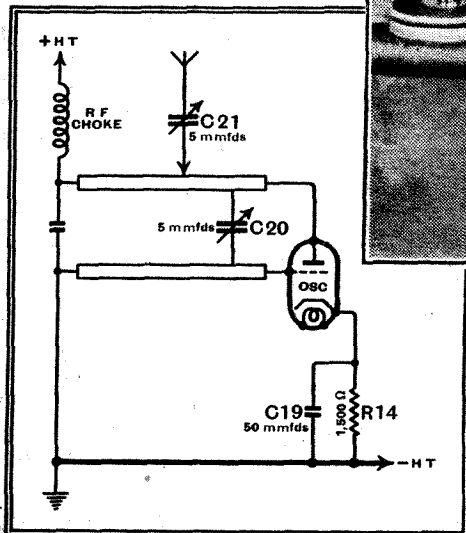

Fig. 7.—Good frequency stability at the very high frequencies can be obtained with this circuit used as a transmitter.

At still lower frequencies, apart from the small physical size, the Acorn has little advantage over the ordinary type of valve. Fig. 8 shows a suitable circuit which is similar to that used at the lower frequencies, apart from some of the component values. The ZA1 valve is coupled to a super-regenerative detector similar to that shown in Fig. 1, with considerable improvement in selectivity and reduction

in radiation from the oscillating detector. The coils L7 and L9 should be similar to those described in Table 2, but due to the larger condensers needed to give a wider tuning range, about 30 per cent, fewer turns should be used. The aerial coil L8 should have about 6 turns of 16 SWG wire wound to 1/2 in. diameter.

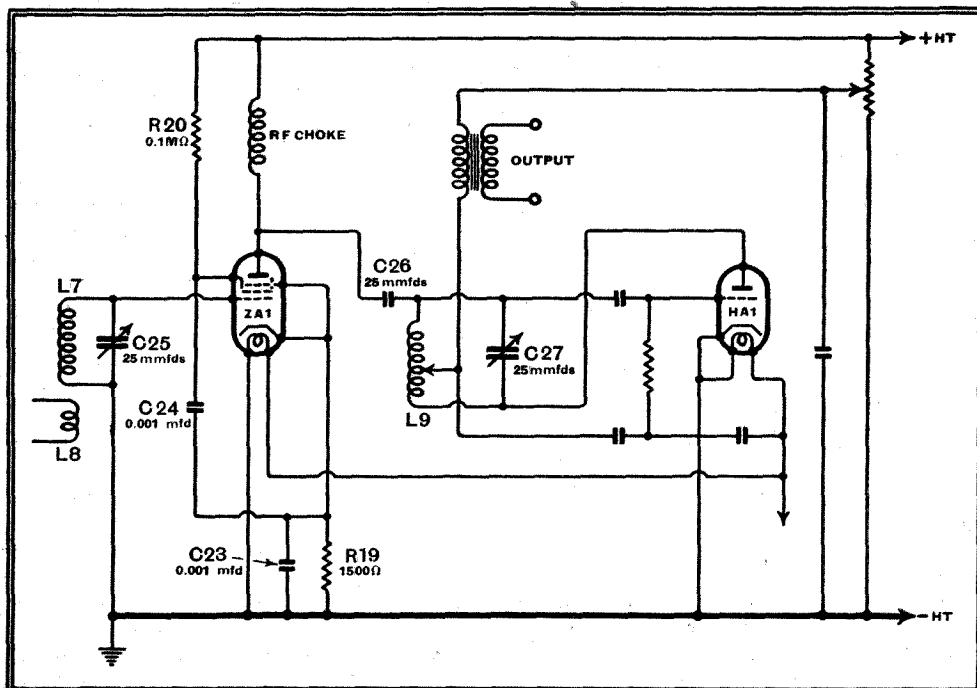

Fig. 8.—An Acorn pentode used as an RF amplifier followed by a triode of the same type arranged for ultra-short-wave reception.

Many other types of super-regenerative circuits using these valves could be devised. Suppressor injection of the interruption or "quench" frequency can be employed, and this method of operation would seem to have several advantages. Independent control of the various voltages is available with this scheme, and although little practical work has been done with this particular arrangement, it is one that is well worth further investigation.

As a frequency changer valve in conjunction with a separate oscillator the

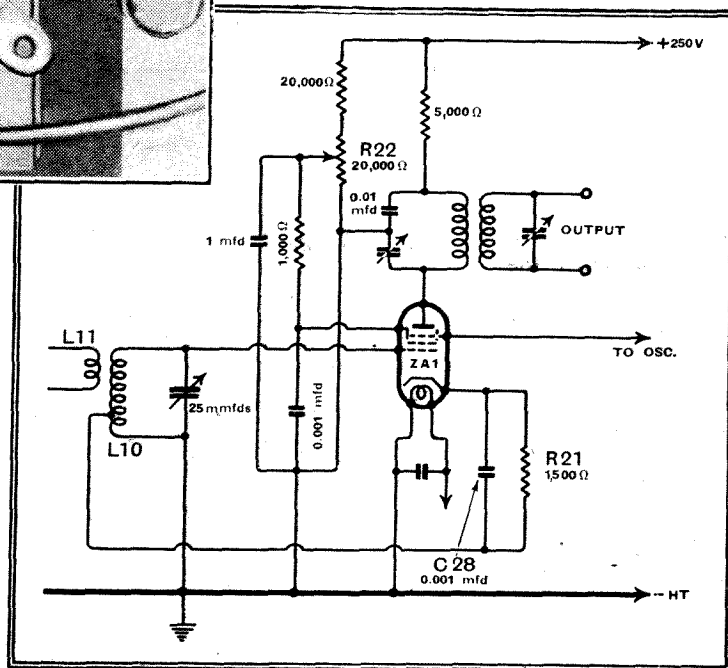

Fig. 9.—Frequency changer circuit for UHF reception using an Acorn pentode with RF regeneration and separate oscillator.

ZA1 will give good results, using the circuit shown in Fig. 9. To increase the stage gain, regeneration is produced by tapping the cathode into the grid coil, and it is controlled by variation of the screen voltage. If regeneration is not required, the ZA1 cathode may be returned to earth, and a further ZA1, using part of the circuit of Fig. 8, used as an RF amplifier. As before, the coils used for 50-60 Mc/s work should consist of about 8 to 10 turns of 1/2 in. diameter, the exact frequency coverage being obtained by altering the spacing of the turns—i.e., pulling the turns apart reduces the inductance and vice versa. It should be remembered that the usual amplifier using an IF of 460 kc/s is hardly suitable for use in an ultra-high-frequency superheterodyne; frequency instability of the transmitter and receiver will be emphasised, and satisfactory reception will be impossible. A high IF of 5 megacycles, having a band width of, say, 50 kc/s, will obviate this and at the same time enable high fidelity broadcast programmes on the ultra-high frequencies to be received.

Acorn valves are, of course, not required in the IF amplifier but only for the frequency-changer, local oscillator and RF stage if one is used.

# More About Magnetic Tuning

## SINGLE-KNOB CONTROL OF MULTI-CIRCUIT SETS

By L. de KRAMOLIN

**T**HE sensitivity and selectivity of the single-circuit receiver considered in previous articles can be improved by the provision of reaction applied through an additional winding on the RF core lying between the poles of the "tuning magnet." Adjustment of reaction from a distant control point can be carried out, as indicated in an earlier article, by varying either the grid bias, the anode voltage, or (when a multi-grid valve is used as a detector) the auxiliary grid voltage, by means of a potentiometer or other device. With such a receiver quite useful long-distance reception is possible under good conditions, but, naturally, for regular reception at considerable ranges a multi-circuit receiver is indispensable.

In constructing such a receiver the most straightforward thing to do is to give each circuit its full complement of tuning components, so that at the control point there will be as many adjustable resistances as there are circuits, each to be adjusted separately, like the condenser knobs on an old-fashioned TRF receiver. If the field currents for the various tuning magnets can thus be regulated individually the design of a multi-circuit receiver presents no special difficulties—at least as regards its remote control—compared with a single-circuit receiver.

If, however, single-knob tuning is to be effected by means of a more or less rigid mechanical coupling between the in-

lengths throughout the whole wave-range, while in a superhet receiver the connection between the various tuning elements must be such that as the tuning is changed the frequency of the input circuit must differ from the frequency of the local oscillator by a constant amount which is equal to the frequency of the intermediate-frequency circuit. Although this requirement would seem to be more difficult to fulfil than the "straight" receiver's requirement of equal frequencies, there are—as will be seen later—various considerations favouring the choice of the superhet principle.

In addition to the method of mechanical coupling

Fig. 2.—A similar circuit to that of Fig. 1, but with the "trimmer" resistances  $R_1$ ,  $R_2$ ,  $R_3$  connected in series with the electro-magnet windings

mentioned above, a coupling giving simultaneous control of the various magnetic variometers can readily be obtained by the arrangements shown in Figs. 1 and 2, where the variometers are connected in series or parallel to a common regulator

common regulating resistance, and B the common source of current. Additional resistances,  $R_1$ ,  $R_2$ , and  $R_3$ , are also provided.

In the "series" connection of Fig. 1 these resistances are introduced in parallel with their respective magnet windings, while in the "parallel" circuit of Fig. 2 they are in series with their magnet coils. In the former case they are of considerably higher resistance than their corresponding magnet windings, whereas in the latter case they are of considerably lower resistance. They play the part, in a magnetically tuned receiver, of the "trimmer" condensers in an ordinary receiver tuned by variable condensers. The discrepancies in tuning between the various individual circuits, due to differences in connecting-lead capacities and other factors, can be corrected by the separate adjustment of these resistances, which per-

*In our issues of February 24th and March 3rd, 1938, we described a system of tuning in which the inductance of a coil is changed by varying the permeability of its iron-dust core by means of an electro-magnet. The application of this system, which seems to offer interesting possibilities for remote control, is now considered in relation to multi-circuit receivers.*

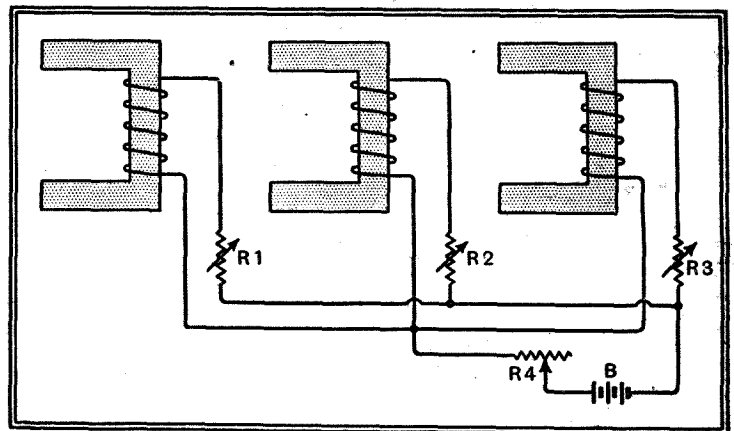
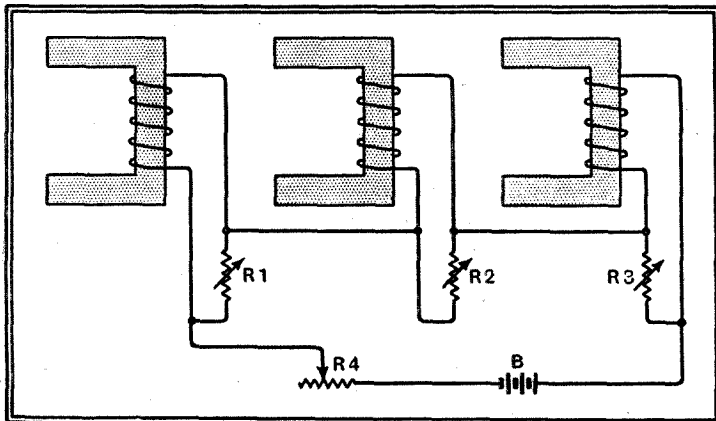

Fig. 1.—Skeleton diagram showing application of magnetic tuning to a 3-circuit TRF set. Main tuning is controlled by  $R_4$  which is in series with the fine adjustment rheostats  $R_1$ ,  $R_2$ ,  $R_3$ .

dividual magnetic-field regulators, then the ganging troubles arise which are common to all such multiple arrangements. In the case of a multi-circuit "straight" receiver, for instance, all the circuits must be kept aligned to exactly the same wave-

and a common source of magnetic-bias current. In these diagrams the "tuning" magnets of three variometers are shown; their high-frequency cores, with their oscillatory-circuit windings, are omitted for the sake of simplicity.  $R_4$  is the

mit the inductances of their corresponding tuning circuits to be varied individually. If necessary the capacities of the various tuning circuits can also be corrected by the use of variable condensers or the addition of "trimmers" to fixed condensers.

The arrangements shown in Figs. 1 and 2 thus correspond, in their action, to a system of three mechanically coupled rotating plate condensers, with the difference that the control element, the resistance  $R_4$ , simultaneously varies the inductances, instead of the capacities, of the oscillatory circuits. In the preceding articles of this series a difficulty in connection with the scale calibration of magnetic variometers was discussed, and it was pointed out that unless expensive special materials were employed for the magnetic circuit a certain back-lash effect due to the remanence of the ferro-magnetic materials had to be taken into account. It might be expected that this difficulty would become serious in the case of the simultaneous tuning of several circuits. Fortunately, however, the normal production processes yield sufficient uni-

**More About Magnetic Tuning—**

formity to render the different variometers so similar in their behaviour that the backlash is practically the same for them all and interferes very little with the alignment of the "ganged" circuits. In this respect the magnetic variometers are, in fact, no more troublesome than mechanically ganged rotating condensers.

However, in cases where very exact alignment is necessary it will happen, as it does with ganged condensers, that the exactness is not satisfactory over a wide frequency range; for, even if the tuning elements themselves are perfectly matched, the differences in connecting leads and other disturbing factors may well be enough to upset the overall alignment. To avoid this trouble we may adopt the well-known plan of limiting the waveband so that the deviations in question become negligible.

**Obtaining Accurate Ganging**

In the case of ordinary variable-condenser ganging, each condenser may be provided with slotted end-plates, and the whole wave-band (say, 200-600 m) to be covered by the tuning adjustment may thus be divided into seven narrow subdivisions, corresponding to the seven segments of the end-plates; over each narrow wave-band exact alignment can be obtained by the suitable bending of the corresponding plate segment. A similar arrangement for the case of magnetic variometers is shown in Fig. 3 for a two-circuit combination. The two tuning magnets  $M_1$  and  $M_2$  are connected in parallel across the battery with the regulating resistance  $R_1$  in series. In the lead to  $M_2$  there is another variable resistance,  $R_8$ , which is small compared with the winding resistance of  $M_2$ . The current from the active part of  $R_1$  is led direct to  $R_8$  and its magnet  $M_2$ , but reaches the magnet  $M_1$  only after passing through one or other of the separately set equalising resistances  $R_2 \dots R_7$ ; which of these resistances is in action is determined by the position of the sliding contact on  $R_1$ . In this way the total inductance range to be covered

Fig. 3.—A correcting arrangement giving extremely accurate alignment; it is analogous to the split end-vane device in ganged condensers.

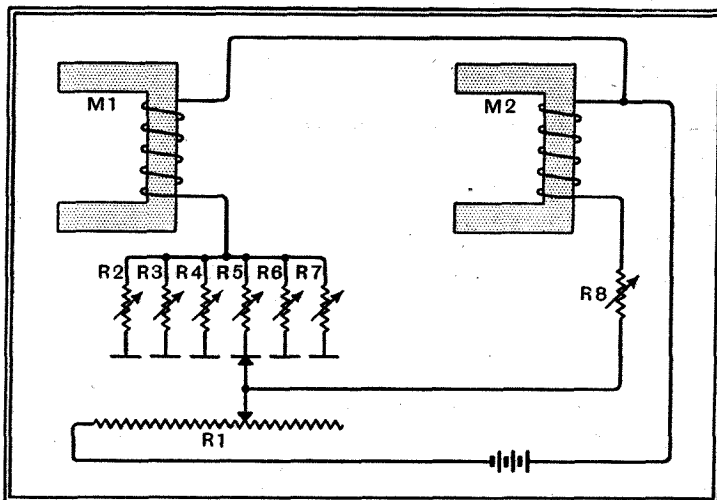

by the two variometers is divided, by the contact segments belonging to the resistances  $R_2 \dots R_7$ , into narrow sub-ranges which can be matched separately by the setting of these resistances; the result is that alignment errors over the whole

tuning-range are practically eliminated.

An arrangement according to Fig. 3 thus corresponds to two mechanically ganged condensers, one of which has an end-plate with five slits. As in the case of ganged condensers, it is not necessary to provide each tuning element with a separately adjusting correcting device; if there are  $n$  elements it is sufficient to provide  $n - 1$  correcting devices. The resistances  $R_2 \dots R_7$  can be of extremely simple type. A satisfactory form is found to be a small rod of ceramic material wound with bare resistance wire, as in Fig. 4, where the winding,  $W$ , is terminated at the two metal caps  $P_1$  and  $P_2$ . The adjustment is carried out with the help of a soldering iron and a little solder by short-circuiting fewer or more turns of the winding; if too many turns are cut out, this can easily be corrected by brushing away the hot solder with a wire brush, the winding being spaced widely enough to allow the bristles to pass between.

Such cartridge-fuse pattern pre-set resistances present the advantages of cheapness and high constancy. Moreover, if the main regulating resistance ( $R_1$  in Fig. 3) takes the form of one of the usual commercial variable potentiometers, where the resistance strip, on an insulating carrier, is bent into a circle and is rubbed by a concentrically mounted springy contact arm, these cartridge resistances can be mounted in holes (parallel to the axis) in the base of the potentiometer, so that their metal caps,  $P_1$  (Fig. 4) form a circle of contact studs concentric with the resistance strip. Then the rotating spring contact, as it moves along the resistance strip, makes contact also with one after the other of the metal caps, passing from one to the other—if the width of spring and the spacing of the caps are correct—without a break.

One objection to the arrangement shown in Fig. 3 is that a separate remote-control lead is necessary for every tuned

involved in which the receiver is to be controlled from any one of a number of control points, it may be desirable to economise in the extra connecting lines by an arrangement such as is seen in Fig. 5; this is particularly the case if the receiver is to cover so wide a range of frequencies that it will be necessary to carry out changes of waveband.

In the arrangement of Fig. 5 the same sub-division of a waveband into a number

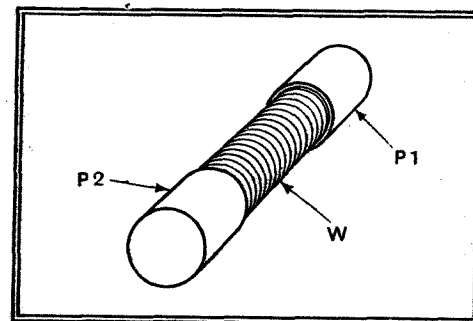

Fig. 4.—Construction of a correcting resistance for the circuit of Fig. 3.

of sub-bands for the sake of more accurate ganging alignment, is carried out, but in this case the switching over from one sub-band to another is accomplished at the receiver itself instead of at the control point. A remote-control switching mechanism is therefore necessary. Since, however, most receivers today have to cover so large a range of wavelengths that a waveband switch is an essential component in any case, this fact does not involve any great complication. It is true that the number of contacts on the wave-change switch must be increased, but this brings with it the following advantages in addition to the saving of a number of additional remote-control lines.

**Waveband Switching**

The resulting reduction of the frequency band which has to be covered by a variometer means either that the necessary magnetic-control energy can be reduced, or that the damping of the magnetically tuned circuit can be diminished. Thus, in order to cover with the least possible expenditure of energy a frequency range of 1:3, the RF core of a magnetic variometer has, as a rule, to be made with a permeability rather greater than that of ordinary RF cores. The latter, constructed merely from the viewpoint of keeping down losses as much as possible, have a ring core permeability of from 10 to 20 (by ring core permeability is meant the permeability of an RF core material as measured on a closed ring of that material), whereas for the RF core of a magnetic variometer a value of about thirty-five has been found to be desirable, for the reason mentioned above.

If, however, in the arrangement of Fig. 5 the frequency range of the individual wavebands is considerably narrowed (and their number correspondingly increased) for the sake of more accurate alignment, then either the magnetic-

circuit of the receiver. If there is to be only a short distance between the control point and the receiver, this objection is not a serious one. But if the receiver is to be situated a long way away from the control point, or if an extensive system is



**More About Magnetic Tuning—**

tuning energy consumption can be reduced (or the magnet dimensions decreased) by retaining the material of higher permeability, or else this material can be replaced by the more ordinary RF core material, with a consequent diminution of the circuit damping. In the latter case it is also possible to introduce an air gap between the tuning-magnet poles and the RF cores, so that the latter are not in direct contact with the former. This also produces a diminution of the circuit damping, leading to values similar to those obtained with good RF iron-cored coils.

The arrangement shown in Fig. 5 has a further advantage in that it provides a form of fine adjustment. In an ordinary condenser-tuned receiver there is, as a matter of course, a step-down gear between knob and condenser spindle, so that the knob must make a number of full revolutions before the spindle rotates through 180 degrees. This facilitates accu-

The drive for the wave-change switch may be provided by the leakage field of one of the tuning magnets. Thus in the diagram (Fig. 5) a lever, H, pivoted at A is mounted near the tuning magnet M<sub>1</sub>. It carries at its free end the ferro-magnetic armature X, which is acted on by the field of M<sub>1</sub>. The movements of the lever H are transmitted by the leaf spring Y to the ratchet wheel Z driving the spindle U, which carries the two triple contact arms V. These arms make contact progressively with the two sets of contact 11...16 and 21...26, to each of which is connected a pre-set adjustable condenser (or a fixed condenser of suitable value with a small trimmer condenser in parallel). These condensers are so graduated that in conjunction with the inductances L<sub>1</sub> and L<sub>2</sub>, respectively, they form tuned circuits whose frequency ranges (as the inductances are varied) just overlap. If the original receiver had two wave-

in action at the receiver is clearly indicated at the control point. Such a Maltese cross device must be provided with a stop to prevent it from being turned backwards.

An arrangement such as Fig. 5 provides an accuracy of alignment, an ease in adjustment (equal to that of any mechanical fine tuning), a low damping of the tuned circuits, and a simplicity in the matter of connecting leads to such an extent as to make it eminently suitable for the control of multi-circuit "straight" receivers; in fact, although these advantages apply particularly to the use of magnetic variometers, most of them would be found also if any other type of remote tuning were employed.

**TELEVISION PROGRAMMES**

**An hour's special transmission intended for the industry only will be given from 11 a.m. to 12 noon each week-day.**

Vision	Sound
45 Mc/s.	41.5 Mc/s.

**THURSDAY, JULY 7th.**

3, "Rogues' Gallery," a review of the songs of law-breakers. 3.30, British Movietonews. 3.40, 161st edition of Picture Page. 9, Cabaret. 9.20, Gaumont-British News. 9.35, 162nd edition of Picture Page. 10, News Bulletin.

**FRIDAY, JULY 8th.**

3-4.30, "On the Spot," a play by Edgar Wallace. Cast includes Arthur Gomez, Gillian Lind and Joan Miller. 9, "Speaking Personally"—Cecil Lewis. 9.10, Catch-as-catch-can Wrestling. 9.30, British Movietonews. 9.40, Cartoon Film. 9.45, "First Prize a Lady," operetta (Offenbach). 10.5, News Bulletin.

**SATURDAY, JULY 9th.**

3, Cabaret. 3.25, British Movietonews. 3.35, "Thread o' Scarlet," a play by J. J. Bell. 9, Cabaret, including Hildegard. 9.45, Gaumont-British News. 9.55, Music Makers. 10.10, News Bulletin.

**SUNDAY, JULY 10th.**

8.50, News Bulletin. 9.5, Ballet. 9.35, Film. 9.45, Irene Eisinger. 9.55, Cartoon Film. 10.5-10.30, Spelling Bee, III.

**MONDAY, JULY 11th.**

3, Contrasts. 3.15, British Movietonews. 3.25, "Bardell against Pickwick," scenes from Dickens' "Pickwick Papers." 3.55, Cartoon Film. 9, "Speaking Personally"—Rosita Forbes. 9.10, Cartoon Film. 9.15, "A Knock in the Night," play by George Graveley. 9.30, Gaumont-British News. 9.40, "The Last Hour," play by George Graveley. 10, News Bulletin.

**TUESDAY, JULY 12th.**

3-4.15, "The Case of the Frightened Lady," play by Edgar Wallace. Cast includes Walter Hadd, Cathleen Nesbitt and Frederick Piper. 9, C. H. Middleton: In Our Garden. 9.10, Cartoon Film. 9.15, "Ann and Harold," episode 1: Their First Meeting, story by Lewis Goodrich. 9.35, British Movietonews. 9.45, Contrasts. 10, News Bulletin.

**WEDNESDAY, JULY 13th.**

3, "Androcles and the Lion," an old fable renovated by George Bernard Shaw. Cast includes Guy Glover and Esmé Percy. 4-4.20, Preliminary O.B. from the Roehampton Club swimming pool. 9, Queenie Leonard and Richard Hearne in "For No Rhyme or Reason," and Lily Palmer and George Nelson in "Take Two Eggs." 9.30, Gaumont-British News. 9.40, Tennis Demonstration. 9.55, Music-Makers. 10.5, News Bulletin.

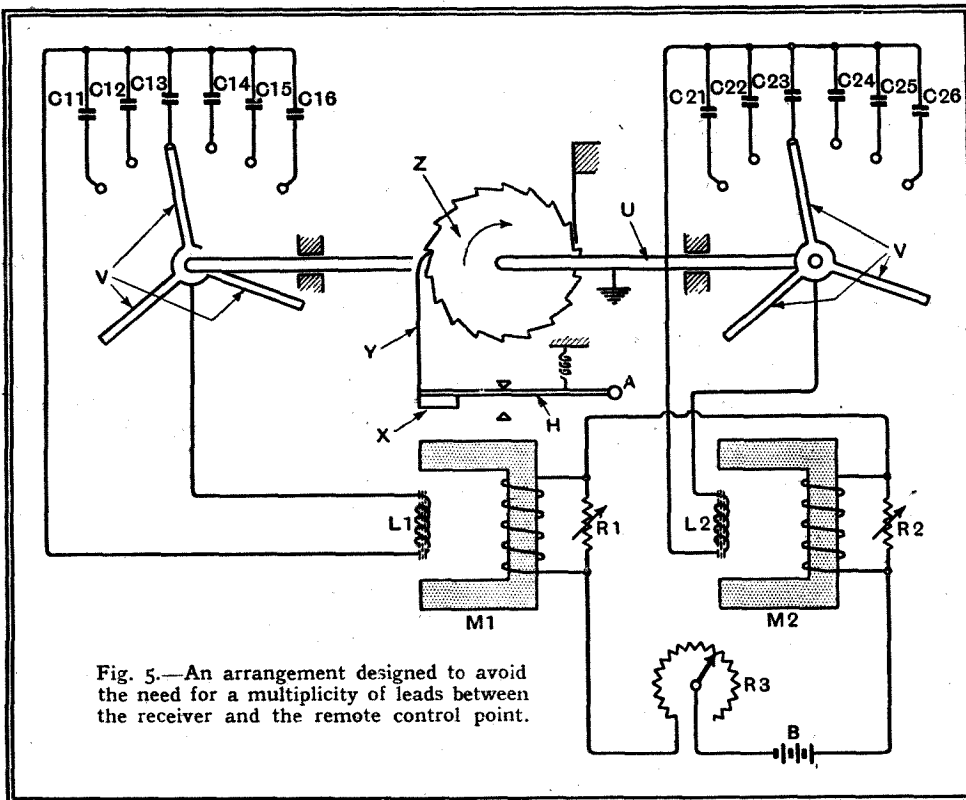

Fig. 5.—An arrangement designed to avoid the need for a multiplicity of leads between the receiver and the remote control point.

rate tuning. On the other hand, in an arrangement on the principle shown in Fig. 3 the knob of the ordinary circular potentiometer turns only through about three-quarters of a revolution to cover the whole waveband corresponding to that covered with an ordinary condenser, so that tuning is liable to be as difficult as it would be with a condenser unprovided with a step-down gear. Of course, this difficulty could be overcome by providing the potentiometer with such a gear. But the arrangement of Fig. 5 obtains the required effect in a purely electrical manner, because the normal wave-range is converted into five or six narrow sub-ranges, and the knob of the control resistance R<sub>3</sub> has, therefore, to be turned five or six times in order to cover the whole original band.

into four or five sub-ranges for the sake of better ganging, then each triple contact-arm must be provided with 2 x 4 or 2 x 5 contacts, distributed over a third of a circle if a triple contact-arm is used, or over 180 degrees if a double arm is employed.

At every complete revolution of the knob of the tuning control resistance R<sub>3</sub> a break in the current occurs as the contact-arm passes through the zero position. The lever H is released, and the ratchet wheel Z is moved on one cog to switch in a new waveband. If a Maltese cross or similar device is provided on the resistance R<sub>3</sub> by which this is made to give a visual indication of the number of times the zero point has been passed through, and, therefore, of the relative position of the distant ratchet wheel Z, the waveband