

The Wireless World

THE
PRACTICAL RADIO
JOURNAL
28th Year of Publication

No. 988.

THURSDAY, AUGUST 4TH, 1938.

Vol. XLIII. No. 5.

Proprietors : ILIFFE & SONS LTD.

Editor :
HUGH S. POCOCK.

Editorial,
Advertising and Publishing Offices :
DORSET HOUSE, STAMFORD STREET,
LONDON, S.E.1.

Telephone : Waterloo 3333 (50 lines).
Telegrams : "Ethaworld, Sedist, London."

COVENTRY : 8-10, Corporation Street.
Telegrams : Telephone :
"Autocar, Coventry." 5210 Coventry.

BIRMINGHAM :
Guildhall Buildings, Navigation Street, 2.
Telegrams : Telephone :
"Autopress, Birmingham." 2971 Midland (4 lines).

MANCHESTER : 260, Deansgate, 3.
Telegrams : Telephone :
"Iliffe, Manchester." Blackfriars 4412 (4 lines).

GLASGOW : 26B, Renfield Street, C.2.
Telegrams : "Iliffe, Glasgow." Telephone : Central 4857.

PUBLISHED WEEKLY. ENTERED AS SECOND
CLASS MATTER AT NEW YORK, N.Y.

Subscription Rates :
Home, £1 1s. 8d. ; Canada, £1 1s. 8d. ; other
countries, £1 3s. 10d. per annum.

*As many of the circuits and apparatus described in these
pages are covered by patents, readers are advised, before
making use of them, to satisfy themselves that they would
not be infringing patents.*

CONTENTS

	Page
Editorial Comment	89
Modern Iron-Cored Coils	90
Linearity and Negative Feedback	93
Home Recording — IV — Surface Noises and Playback Needles	95
Choosing the New Set	98
News of the Week	100
How a Receiver is Designed—XXI	102
Letters to the Editor	104
Random Radiations	106
Broadcast Programmes	106
Recent Inventions	108
Principal Broadcasting Stations	109

EDITORIAL COMMENT

Quality of Reception

Dangers of Sidetracking

TALKING the other day to a designs engineer, we were very interested in a point of view he put forward that in the present trend of development of receivers for broadcast reception it was necessary to keep in mind all the time the primary purpose of a broadcast receiver, lest the designer should be too much influenced by the many diversions which may tend to lead him astray from the main goal.

The purpose of the broadcast receiver is primarily to reproduce as faithfully as possible the performances at the microphone.

All sorts of devices are now available to the designer which are in the nature of refinements but which do not necessarily contribute anything to the improvement of quality of reception and may even mar the capabilities of the receiver unless they are most judiciously introduced. The link between transmission and reproduction at the loud speaker may be likened to a main road, and all the modifications such as AVC, push-button tuning, tone control, tuning indicators, and other devices may be regarded as branch roads which, however attractive in themselves, may tend to divert attention and result in neglect of the main highway.

The risk of this situation arising is probably greater to-day than at any time in the history of receiver development, because there is so much competition amongst manufacturers to introduce new features to their sets and at the same time to insure that no gadgets introduced by competitors are missing from their own receivers. The salesman will tell us that it is the new features in wireless sets which help to sell them to-day and that the public

seem more concerned to know whether these are incorporated than to have assurances as to the quality of reproduction of the instrument.

We do not for one moment suggest that these refinements and additions should not be introduced ; on the contrary they serve a most useful purpose in simplifying control and generally adding to the convenience and efficiency of receivers. But they are only worth while if their incorporation does not result in any compromise with quality of reproduction, which should always remain the main goal of the receiver designer.

Television Sets

No Compromise with Reliability

WE recently referred on this page to the responsibility resting with the manufacturers in any attempt made to popularise television reception by cheapening the receivers. We were urging the desirability of agreement amongst manufacturers to standardise their respective television models as far as possible so as to reduce costs without incurring a risk that unreliable instruments would be distributed to the public.

We believe, however, that manufacturers will find a means of producing television for the public at a much lower cost than at present, by employing a smaller tube and consequently a smaller picture. Such sets are, in fact, already being talked about and should they appear will do much towards popularising television, without being in any way inferior in the matter of reliability. Small sets of this kind would bring television within the reach of many who could not otherwise afford it, yet the larger sets will still be sought after by those who can afford them because of the pronounced advantages of the larger picture.

Modern Iron-Cored Coils

THE USE OF SIRUFER PRESSED IRON-DUST CORES

FOR some years iron-cored coils have been used in radio-frequency circuits and have achieved a considerable measure of popularity. As compared with the older and still widely used air-cored coils, one of their chief advantages lies in their considerably greater efficiency for a given physical size. This advantage is considerable in the commercial field where space is at a premium. It is, of course, only obtained when the iron-cored coil is properly designed, for

iron-dust cores produced by this firm are known under the trade name of "Sirufer." The data on these cores which is included in this article is available through the courtesy of Messrs. Siemens-Schuckert.

The quality of a coil is represented by the symbol Q which is numerically equal to the ratio of reactance to series resistance ($=\omega L/R$), and the higher the value of Q , the greater is the selectivity of the circuit of which it forms a part. For a given value of inductance the amplifica-

CONSIDERABLE development has taken place in iron-cored coils for use at radio frequencies and in this article some details are given of the types used in Germany. One of the greatest advantages of this type of coil is the ease with which an inductance trimmer can be obtained, and in many of the cores described provision is made for such adjustment.

frequency and which is made up of two parts, commonly known as the skin effect and the proximity factor. The first of these is a form of eddy-current loss which results in the current flowing chiefly in the outer layer of the conductor, while the second represents an additional loss due to the interaction between the different turns of a coil.

To keep the first component low, the wire diameter should be as large as possible; but to keep the second effect at a minimum stranded wire should be used with as fine strands as possible for a given wire section. In addition the self-capacity must be low and all dielectrics of as good quality as possible.

Coil Performance

The curves of Fig. 1 are representative of good air-cored coils of various winding styles. Curve 1 is for a single-layer coil of fairly large size which has a self-capacity of only $3.45 \mu\mu\text{F}$. Curve 2 shows the performance of a sub-divided slot winding with a Trolitul former; the self-capacity of $4.13 \mu\mu\text{F}$ is again low. Curve 3, for a cross or Universal-wound coil, shows a considerably poorer performance and a high self-capacity—about $12.6 \mu\mu\text{F}$. Much better results are obtained with an oblique winding, curve 4, and the best of all with an iron-cored coil, curve 5.

The losses in iron-cored coils are similar to those found in air-cored types, but there are additional components due to the core. The core introduces losses in three ways. There is firstly the hysteresis loss, which depends chiefly on the intensity of the

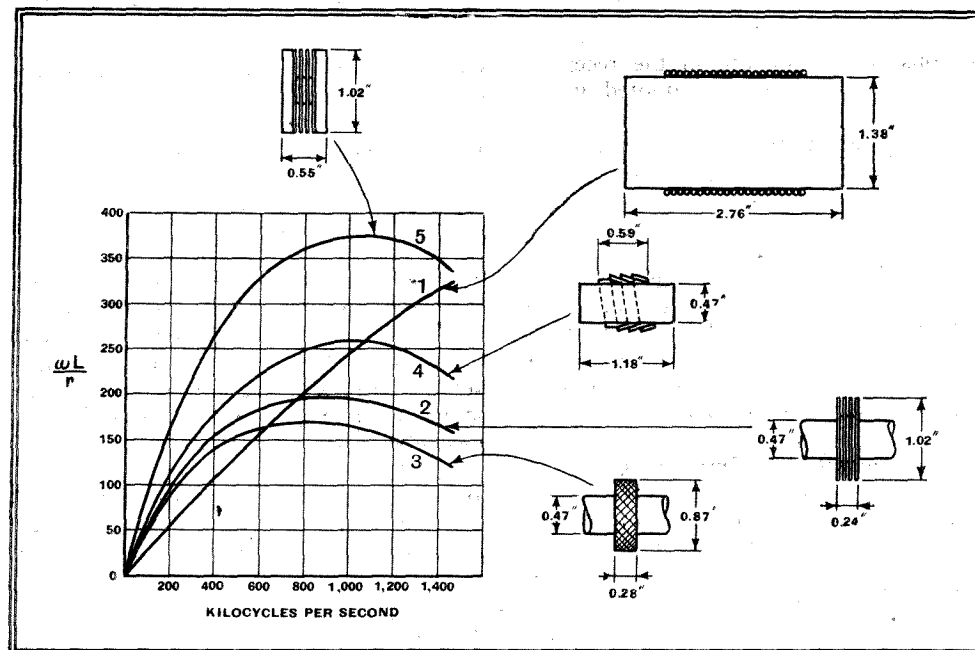

Fig. 1.—The curves show the efficiency (Q) of various types of coils. Curve 1 is for an air-core solenoid, while curve 2 shows the performance of a sub-divided slot-wound coil, again with an air-core. A cross-winding gives the results of curve 3, and an oblique winding gives curve 4. The improved results with a sub-divided slot-wound coil with a bobbin-type iron core are well brought out by curve 5.

when it is not it may be much worse than an air-cored coil.

In Germany a large amount of work in the development of iron-cored coils has been carried out by Siemens and Halske, who are represented in this country by Siemens-Schuckert of 30-34, New Bridge Street, London, E.C.4, and the pressed

tion obtainable from a valve and tuned circuit also increases with the Q of the coil.

The series resistance of an air-cored coil consists of several components. There is first the DC resistance, which is independent of frequency; secondly there is a component which varies as the square of

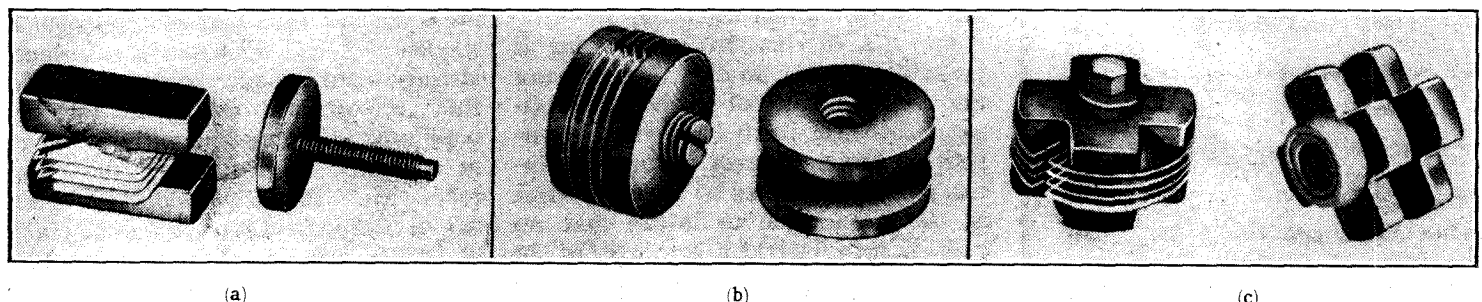

Fig. 2.—A typical series of iron-cores is shown in this photograph. At (a) there is depicted an H-core with separate inductance trimmer plate, and at (b) and (c) the bobbin and reel type cores. These have a centre-screw for inductance adjustment.

Modern Iron-Cored Coils—

field and the characteristics of the iron; it is proportional to frequency. The second way in which the core introduces losses is through the magnetic flux lagging behind the magnetic force which produces it. This is again proportional to frequency.

One big advantage of iron-cored coils lies in the ease with which it is possible to vary the inductance over a small range by a mechanical change in a part of the core. This is particularly valuable as it enables an inductance trimmer to be easily arranged which can be used for matching

coil. (b), is also available with the hexagon-type adjustment.

There are many occasions when high-efficiency cores of this type are unnecessary and a core proper without end-cheeks can then be adopted. The usual procedure is to wind the coil on a former in which a

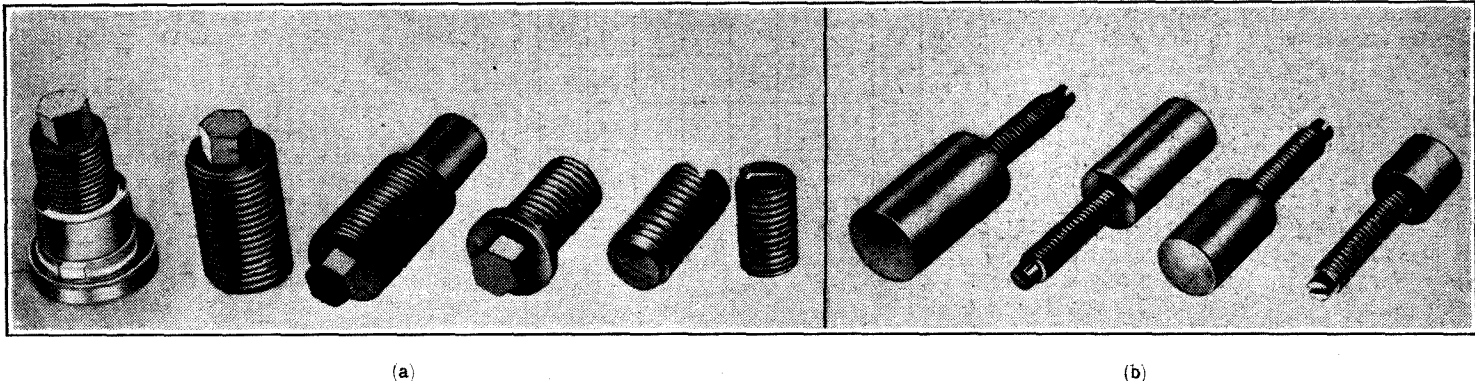

Fig. 3.—A group of simple cores for use with cross-wound coils is shown at (a); the cores are threaded so that they can be screwed into the coil former for inductance adjustment. Plain cores fitted with brass fixing screws are shown at (b).

The third source of loss is due to eddy currents in the core and these losses are proportional to the square of frequency, and represent the principal part of all the iron losses.

Since the iron-cored coil has all the forms of loss of the air-cored type in addition to its core losses, it may be asked how it can be better. If the normal losses were equally present in both types, of course, an iron-cored coil would inevitably be worse than an air-cored one. They are not, however. Because of the iron core much less wire is needed to obtain a given inductance than with an air core, and this alone means a big reduction in the copper losses. Consequently, the losses common to both types are greatly reduced with an iron core and with proper design the additional iron losses are smaller than the improvement, with the net result of a better coil.

The optimum permeability for a powdered-iron core depends on the operat-

the coils while they are in the receiver. The precise arrangement adopted varies with the type of core.

One of the earliest types of core was that shown in Fig. 2 (a). The core is of H shape and the effective permeability, and hence the inductance of the coil, is varied by moving the tuning disc in relation to the core. The disadvantages of this scheme are that only a small change of inductance can be secured, the change is not proportional to the alteration in the position of the disc, and the mounting of core and disc must be rigid.

Inductance Trimming

These difficulties are overcome in the bobbin and cross-reel type cores, Fig. 2 (b) and (c). As the name implies, the reel-core consists of a centre-core with end cheeks moulded in one piece of powdered iron. The inside of the core is threaded and a rod of powdered iron can be

suitable core is placed. Threaded cores are available which can be screwed into the coil if a thread is cut on the inside of the coil former. A number of these cores is shown in Fig. 3 (a), and in (b) appear plain cores with a threaded brass end screw. With both types the inductance is readily adjusted by screwing the core further into the coil. When this inductance adjustment is unnecessary, plain solid or hollow cores are used, or cores with one flange (mushroom-type). A selection of these appears in Fig. 4 (a), while in (b) are shown a number of cores made of an iron specially developed for short waves.

Apart from efficiency, the material used for the cores must have good mechanical strength in order to stand up to the stresses which occur during mounting and in the set itself. With Sirufer material this is achieved by the selection of suitable binding media as well as by shaping the cores correctly. Good thermal constancy is another requisite of the core. Mechani-

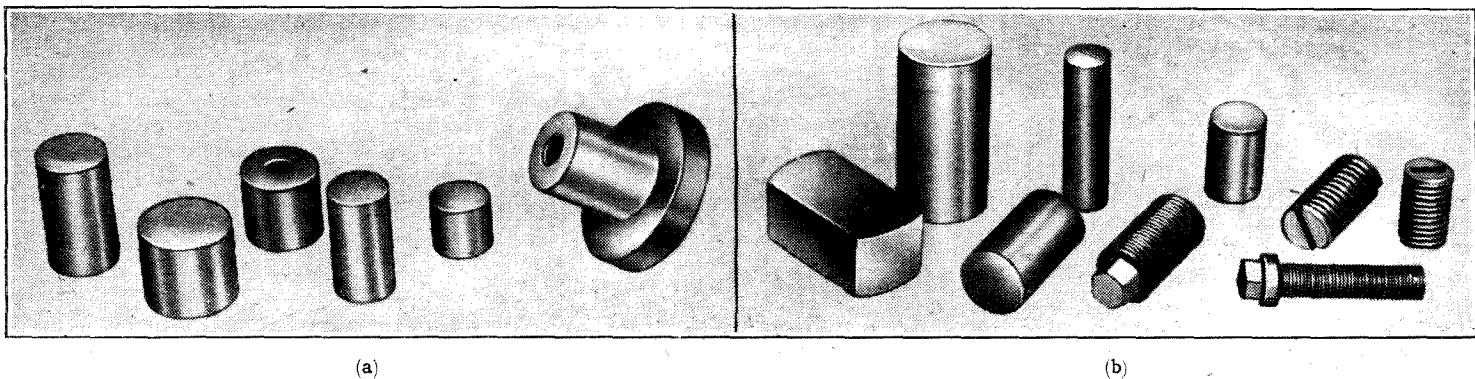

Fig. 4.—Where inductance adjustment is not needed plain or mushroom cores can be used as shown at (a). For short-wave work a number of special cores is available (b).

ing frequency and upon the kind of stranding of the wire, decreasing with frequency and with an improvement in the conductor. The precise effect is that while the iron losses increase with permeability, the copper losses decrease, and the best results are obtained when the two factors balance. For the medium waveband the optimum permeability is about 3 to 4.

screwed in for inductance adjustment. The cross-core, (c), is of similar construction; the end cheeks, however, are not circular but in the form of a cross. The centre-screw for inductance adjustment has a hexagon head for a spanner instead of a saw-cut for a screwdriver. This core is more convenient when many leads must be brought out of the coil. The bobbin

cal alteration of the core does not occur for temperatures up to 65 deg. C., and with certain cores up to 120 deg. C.

It is obviously important that the temperature coefficient should be low, otherwise day-to-day inductance variations will occur. With Sirufer iron it is exceedingly small and negative. A further requirement is that the permeability should not

Modern Iron-Cored Coils—

change with time. Actually the variation found over long periods is less than 0.1 per cent. The permeability should also be unaffected by a direct current flowing through the core. Tests with a bobbin-type core and a 200 μ H coil show an increase of permeability of 0.05 per cent. for a DC change of 10 mA. through the coil. Certain Sirufer coils are unaffected by tropical conditions.

Screening

Iron-cored coils have a much smaller stray field than air-cored types, and it is consequently possible to use a relatively smaller screening can without any great sacrifice in efficiency. The enclosed and semi-enclosed core types naturally have an advantage in this respect over the simpler bar-cores, and the effect of a screen is well brought out by the curves of Fig. 5. These show the Q-value of a coil with a roller-type core unscreened and fitted in cans of 48 mm. and 32 mm. diameter respectively. In general, it is advisable to

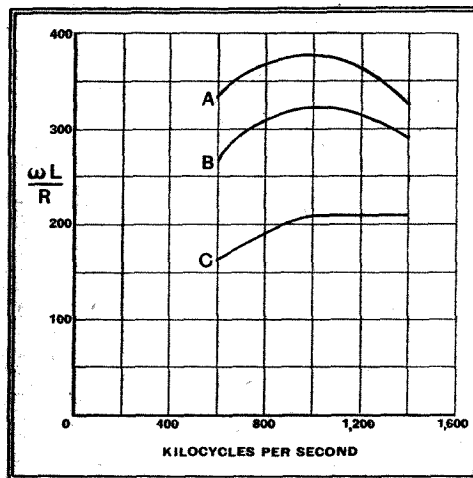

Fig. 5.—The effect of a screening-can on an iron-cored coil is brought out by these curves. Curve A shows the performance of an unscreened coil with roller-type core, while B and C show the effect of using cans of 48 mm. and 32 mm. diameter respectively.

maintain a clearance of at least 15 mm. between screen and core.

better and more interesting than its predecessor.

It is impossible to give any real idea of the book from a mere list of contents; it is sufficient to say that it is divided into parts dealing respectively with Astronomy (including mechanics and especially clocks), Chemistry, Engineering (or the production and utilisation of power), Biology, and Psychology. This whole outline of modern science is displayed against a social background; if one can attempt to summarise a thousand pages in a few lines, Professor Hogben's thesis is that science should not be viewed as a collection of abstruse theorems to be accepted without argument from implicit trust in their inventors (history shows that such theories rarely endure unmodified for more than a generation or two, and are often completely exploded in less than a hundred years); it is rather the sum total of experimentally determined facts, collected and intelligibly classified as in a card index, to which the theories are the "guide cards," and in the main useful, or potentially useful, for the improvement of the standard of life and for the increase of the comfort and security of mankind.

The facts of science are not to be believed as an act of faith, or from reverence for

AVC by Applause

IN a public-address system, where the orator faces his audience in person, he can wait for any applause or laughter to subside, or he can shout down that or any other interference, as he thinks fit. But if a loud speaker is being fed from a "talking film" in a cinema theatre, or is being used to relay a broadcast programme in a concert room or lecture hall, prolonged laughter or applause usually has the effect of "swamping" whatever is being said for the time being. Of course, it is possible to increase the volume, whilst the interference lasts, by manual control, but this is more or less of a makeshift.

A more ingenious idea is to utilise the "noise" produced by the audience as a means for controlling the output from the speaker, so that the latter automatically "rises to the occasion" and continues to make itself heard through the prevailing uproar.

The arrangement shown in the figure (Patent No. 485005) has recently been designed for this purpose. The loud speaker is energised, say, from a talking film, through an amplifier A. Suspended from some suitable point in the auditorium is a microphone M, which is used to provide an AVC voltage for supervising the output from the speaker. The sounds picked up by the microphone are fed to an amplifier MA, the output from which is rectified at D, and the resulting voltage fed through a variable resistance R to a biasing resistance R₁.

The microphone M will, of course, pick up the normal sounds emitted from the loud speaker, and since this should produce no "regulating" effect one way or other, it is necessary to use a balancing voltage. This is applied from the loud

"Shouting Down" the Audience

Method of controlling output of PA system by noise in auditorium.

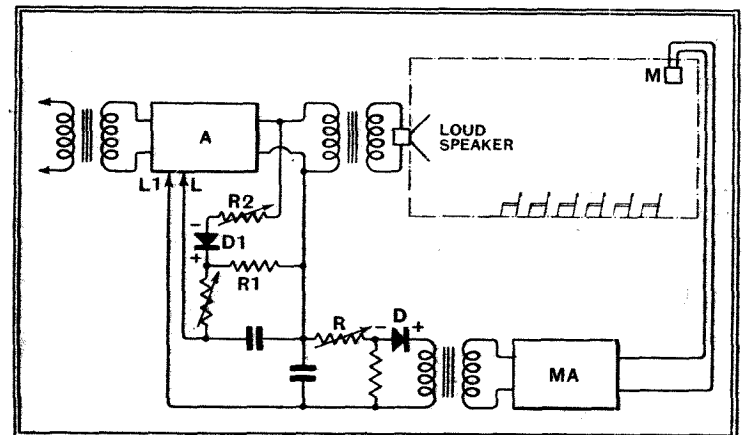

speaker through a shunt circuit containing a resistance R₂, detector D₁, and the common resistance R₁. The "balancing voltage" from the loud speaker is, in practice, made somewhat larger than the normal pick-up voltage from the microphone so as to avoid any tendency for the system to "sing" and so boost the loud speaker unnecessarily.

As soon as any prolonged laughter or applause occurs, the microphone voltage builds up across the resistance R₂ in excess of the "balancing" voltage, and applies an AVC bias through the leads L, L₁ to the grid of one of the valves in the amplifier A. The output from the loud speaker increases accordingly until the disturbance dies down, whereupon normal conditions are restored.

Science for the Citizen. By Lancelot Hogben. Illustrated by J. F. Horrabin. Pp. 1120 with 479 figs. George Allen and Unwin, 40, Museum Street, London, W.C.1. Price 12s. 6d.

THOSE who have read Professor Hogben's "Mathematics for the Million" will expect much from "Science for the Citizen," nor will they be disappointed, for it is even

traditional authority; they are based on the results of experiments which anyone can repeat for himself (given sufficient skill). Indeed, many of the experiments illustrated by Horrabin are seen to demand little specialised ability and the minimum of apparatus, so that they could be performed by any (and doubtless will be performed by many) intelligent schoolboys.

The reader will find that he is adopting the scientific habit of mind, he is shown how to think for himself (which is, or should be, the whole object of education), and he will learn that it is not necessary to believe, without thinking, everything he may read, whether it be an advertisement or a piece of skilfully camouflaged official government propaganda.

The whole book can be read and understood without any previous mathematical or scientific training; it is written for, and will be enjoyed by, "the man in the Tube," no less than by the trained scientist, who should read it for the knowledge he will gain of other branches of science as well as for its entertainment value. Even the politician could understand and profit by it, if he would, although, as Professor Hogben says, (with honourable exceptions) "English politicians are probably the most expensively uneducated class of people alive at the present day."

C. R. C.

Linearity and Negative Feedback

HOW AMPLITUDE DISTORTION IS REDUCED

THE improved frequency response which is obtainable with a negative feedback amplifier is well known, but the question of amplitude distortion does not seem to have received the same attention. The author was recently called upon to produce an amplifier with negligible amplitude distortion and phase shift at frequencies between 50 and 1,000 cycles. Preliminary experiments indicated that while ordinary straightforward methods gave a reasonable approximation to the conditions required, the results just fell short of the completely distortionless amplification which was demanded.

Attention was therefore directed to the use of negative feedback, for one of the catchwords of this system of amplification is that the gain obtained is substantially independent of the valves or even of the amplifier itself, and is merely a function of the percentage feedback. If this is the case, then theoretically it should be possible to use quite a bad amplifier and still obtain satisfactory results, and the question to be determined was whether this apparently ideal state of affairs could be achieved in practice or whether, as is usually the case, there was some unsuspected limitation lurking unseen.

It may be said at the outset that the experiments did bear out the theory but that, equally to be expected, there was a limitation which requires to be appreciated if the proper results are to be obtained. Let us examine very simply the theory of a negative feedback amplifier. If the normal amplification of the am-

plifier is A , and we feed back from the output to the input a small portion of the output voltage, say, β , the gain of the amplifier as a whole will be reduced (assuming that the feedback is negative, i.e., in such a direction as to reduce the amplification). Consequently, in order to obtain the same output as before the input must be increased by this amount βE , E being the output voltage. The effective input voltage becomes $e + \beta E =$

By J. H. REYNER, B.Sc., A.M.I.E.E.

DESCRIBING investigations made with the help of a cathode-ray tube into the extent by which amplitude distortion can in practice be reduced by means of negative feedback.

$$\frac{E}{A} + \beta E = E \left(\frac{1}{A} + \beta \right)$$

The effective gain of the amplifier therefore is:

$$\text{Gain} = \frac{I}{\frac{1}{A} + \beta} = \frac{A}{1 + \beta A}$$

This can be rewritten in the form

$$\text{Gain} = \frac{I}{\beta} \cdot \frac{1}{\left(1 + \frac{1}{\beta A} \right)}$$

and it will be clear that if the product βA is several times greater than one, the second term under the brackets becomes practically zero, and the gain of the amplifier becomes simply $\frac{I}{\beta}$

Now, this is the condition of affairs for true negative feedback working. The amplification obtained is simply the inverse of the amount of energy fed back. If $1/100$ th of the output voltage is fed back to the input then the amplification overall is 100, provided that the product βA is large compared with unity.

It is this proviso which constitutes the limitation already mentioned. Let us take, for example, an amplifier with a normal gain of 1,000. For the product βA to be large compared with unity, β must be of the order of 0.01 to 0.005. If β is 0.01, however, the gain of the amplifier is only 100, so that we have obtained our independence of valves and

circuit conditions at the expense of 9/10ths of the gain.

If it is permissible to increase the input, then this method is quite satisfactory, and the first test made was to verify whether the negative feedback really did behave in accordance with theory. A simple amplifier of the type shown in Fig. 1 was used. It consists simply of two resistance-coupled triodes, the circuit being normal in every respect with the exception of the fact that the customary by-pass condensers across the bias resistors had been omitted.

Actually this omission of the by-pass condenser in itself introduces a small amount of negative feedback round each stage, but the extent of this is comparatively small in view of the low values of the bias resistors. The bias on the second valve was really too low, resulting in appreciable overloading of this valve under normal working conditions, but for the purposes of the experiment this was an advantage, since it gave a readily observable distortion which should theoretically be cancelled out by the negative feedback.

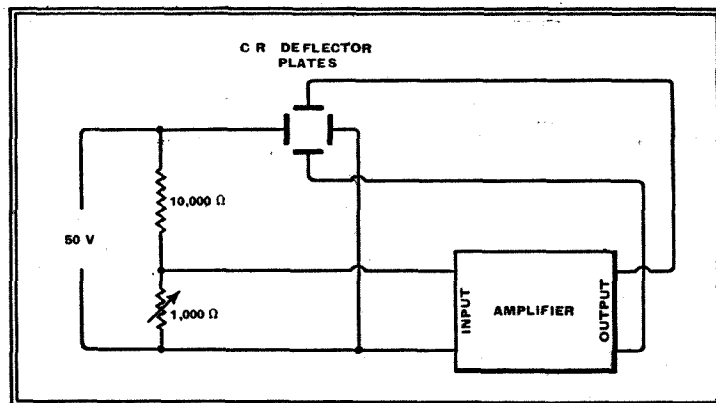

Fig. 2.—Circuit for producing phase ellipse.

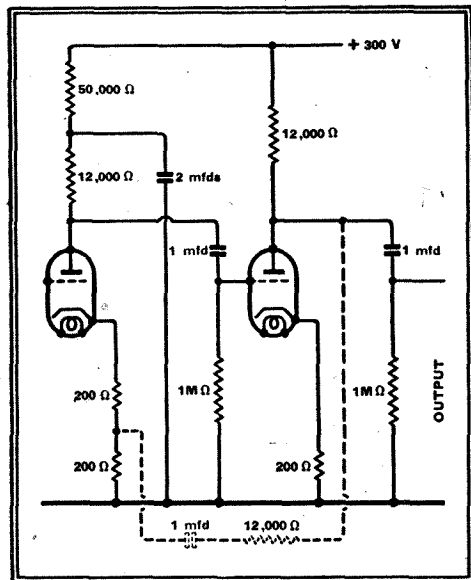

Fig. 1.—Circuit of experimental amplifier; negative feedback connections shown in dotted lines.

For the observation of the distortion a cathode-ray tube was set up to record the phase ellipse, as shown in Fig 2. An input of about 50 volts was applied to the X plates and a small fraction of this input was applied to the input of the amplifier and the output then applied to the Y plates. Under these conditions a distortionless amplifier of no phase shift will show a diagonal line on the screen. If this line is perfectly straight there is no amplitude distortion, whereas curvature at any part indicates departure from strictly linear amplification. If there is any phase shift between input and output, the spot does not follow the same course on its go and return paths but traces out an ellipse, the eccentricity of which is a measure of the phase shift. If there is a 90 deg. phase shift, the pattern on the screen is no longer a diagonal line but becomes a complete circle, and in fact a few minutes of phase shift (i.e., a small

Linearity and Negative Feedback—

fraction of one degree) can easily be detected by this method.

The heavy line in Fig. 3 shows the trace obtained from the amplifier of Fig. 1. It will be seen that there is no phase shift but that there is a very definite amplitude distortion shown by a marked curvature at one end of the line actually produced by the second valve running into grid current.

A small amount of negative feedback was then applied to the amplifier by connecting up the circuit shown dotted in Fig. 1. With the arrangement shown, β was approximately 0.0035, a value which made the product βA equal to 3 for the particular amplifier in question.

Though this is not really large compared with unity, it is approaching the division where this state of affairs is obtained, and the conditions give a fair approximation to true negative feedback. It was found that the input had to be increased practically ten times in order to obtain the same output, and the dotted line in Fig. 3 shows the trace on the tube with ten times the input and the negative feedback circuit in operation. It will be noted that though the output is actually slightly greater than before, the amplitude distortion has almost entirely disappeared. There is a very slight curvature still at the extreme bottom end of the line.

Harmonic Distortion

As a matter of interest, Fig. 4 is introduced to show the original waveform plotted out against a time base in the more usual form, and the flattening of the bottom halves of the waves can clearly be seen in the no-feedback condition corresponding to something like 15 per cent. of harmonic distortion, whereas with the feedback the waveform is a pure sine wave.

The fact that the gain had been reduced so heavily was a disadvantage for the particular circumstances. The normal solution would be to add a further stage of amplification giving a gain of approximately 10 or even more, since it is always possible to increase the feedback with still further improvement in the performance. With a further stage, of course, feedback would have to be introduced into the grid circuit and not in the cathode circuit in

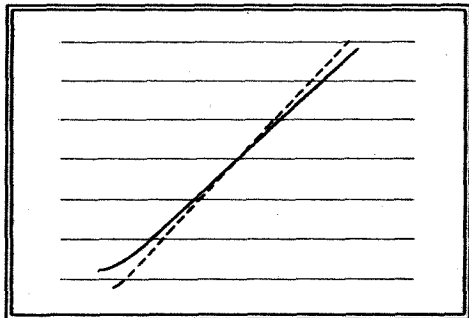

Fig. 3.—Improvement in linearity with negative feedback, as shown by traces on a CR tube. The full line represents normal conditions, while the dotted line shows improvement with feedback $\beta=0.035$; input increased ten times.

order to maintain the correct phase of the feedback, but in the particular circumstances it was desired to limit the stages to two if possible.

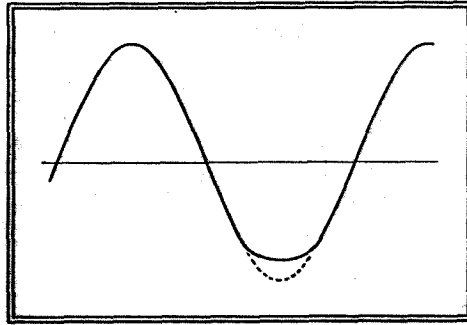

Fig. 4.—Waveform of Fig. 3, showing flattening of bottom peak. Dotted line shows true sine curve.

It was decided, therefore, to reduce the negative feedback slightly, thereby increasing the gain of the amplifier, and at the same time to improve the performance of the amplifier itself, so that the amount of correction required from the negative feedback would be lessened. This was done by increasing the bias on the second stage, not by increasing the cathode resistance itself but by feeding more current through the existing 200 ohm resistor by means of a shunt circuit from the h.t. line. Increasing the bias resistance would have reduced the amplification of the second valve because of the negative feedback around that stage alone, whereas by passing more current through the bias resistor the increased bias was obtained without this disadvantage.

The feedback was then reduced to 0.0017 approximately (i.e., about half its previous value) and the experiment repeated. It was found that although the amplifier was no longer a strictly negative feedback arrangement, since βA was not large compared with unity, being now about 1.5, yet sufficient correction was being introduced to ensure a practically straight line on the tube, now that the overloading on the second valve had been minimised, and actually the amplifier was left in this condition.

Conclusions

In brief, the experiment showed conclusively that if the amplifier is properly designed in the first place to comply with the true conditions for negative feedback, then the individual valves need not be particularly carefully chosen or even correctly operated, since any distortion will be almost entirely compensated for by the negative feedback.

No detailed tests were made during this investigation as to the frequency response of the amplifier other than checking that up to 1,000 c/s the phase distortion was still negligible. It is worth noting, however, that at the frequencies of the order of 4,000 c/s a considerable phase angle was observed. This was due to the fact that phase shift was taking place in the amplifier itself with the result that the phase angle of the voltage fed back was

no longer correct. This is a matter, however, which could easily have been compensated for in the feedback circuit itself, and was only because the amplifier was not running under conditions of full negative feedback.

Television Programmes

An hour's special film transmission intended for the industry only will be given from 11 a.m. to 12 noon each weekday.

Sound	Vision
41.5 Mc/s	45 Mc/s

THURSDAY, AUGUST 4th.

3-4.15, "Laburnum Grove," an adaptation of the play by J. B. Priestley.

9, "Sweet Jam," instrumental session directed by Eric Wild. 9.15, Gaumont-British News. 9.25, Cartoon Film. 9.30, "Exhibition," a panorama of exhibitions from Paris, 1797, to Glasgow, 1938. 10, News Bulletin.

FRIDAY, AUGUST 5th.

3, "Charivari"—the Panache Company in three items from their repertoire. 3.25, Gaumont-British News. 3.35, Cartoon Film. 3.45-4.5, "In the Dentist's Chair," the thriller by Anthony Armstrong.

9, Golf Demonstration, by Ernest Bradbeer. 9.15, British Movietonews. 9.25, Cabaret. 10, News Bulletin.

SATURDAY, AUGUST 6th.

3, Health and Beauty—demonstrations by Punella Stack and members of the Women's League of Health and Beauty, in the grounds of Alexandra Palace. 3.20, Cartoon Film. 3.25, Starlight. 3.35, British Movietonews. 3.45, "Sweet Jam" (as on Thursday at 9 p.m.).

9, "Laburnum Grove" (as on Thursday at 3 p.m.). 10.15, News Bulletin.

SUNDAY, AUGUST 7th.

8.50, News Bulletin. 9.5, Les Sylphides, in Ballet. 9.35, Film. 9.45-10.15, Television Spelling Bee, IV.

MONDAY, AUGUST 8th.

3, O.B. from Wembley of the European Swimming Championships. 3.20, Eric Wild and his Band. 3.40, O.B. from Wembley, continued.

9, "Is Life Worth Living?" an extravaganza by Lennox Robinson. The action takes place in Inish, a small seaside town in Ireland. 10.15, News Bulletin.

TUESDAY, AUGUST 9th.

3, O.B. from Wembley of European Swimming Championships. 3.20, "Rococo." 3.40, O.B. from Wembley, continued.

9, Starlight. 9.10, "Ann and Harold," Episode V. 9.30, Cartoon Film. 9.35, British Movietonews. 9.45, Eric Wild and his Band. 10.5, News Bulletin.

WEDNESDAY, AUGUST 10th.

3, O.B. from Wembley of European Swimming Championships. 3.20, Starlight. 3.30, Crime Clues. 3.40, O.B. from Wembley, continued.

9, Comedy Cabaret, including George Robey and Charlie Higgins. 9.40, Gaumont-British News. 9.50, Music Makers. 10, News Bulletin.

The Wireless Industry

A LEAFLET dealing with the Simmons vibrator-rectifier HT supply unit describes models for 2-, 4- and 6-volt accumulators. Copies are obtainable from the makers, Simmons Bros., 38, Rabone Lane, Smethwick.

W. T. Henley's Telegraph Works Company, Ltd., has declared an interim dividend on the ordinary stock of 5 per cent. (less income tax) to be paid on October 1st, 1938.