

The Wireless World

THE
PRACTICAL RADIO
JOURNAL
29th Year of Publication

No. 1027.

THURSDAY, MAY 4TH, 1939

VOL. XLIV. No. 18

Proprietors : ILIFFE & SONS LTD.

Editor :
HUGH S. POCOCK.

Editorial,
Advertising and Publishing Offices :
DORSET HOUSE, STAMFORD STREET,
LONDON, S.E.1.

Telephone : Waterloo 3333 (50 lines).
Telegrams : "Ethaworld, Sedist, London."

COVENTRY : 8-10, Corporation Street.
Telegrams : "Autocar, Coventry."
Telephone : 5210 Coventry.

BIRMINGHAM :
Guildhall Buildings, Navigation Street, 2.
Telegrams : "Autopress, Birmingham."
Telephone : 2971 Midland (5 lines).

MANCHESTER : 260, Deansgate, 3.
Telegrams : "Iliffe, Manchester."
Telephone : Blackfriars 4412 (4 lines).

GLASGOW : 26B, Renfield Street, C.2.
Telegrams : "Iliffe, Glasgow." Telephone : Central 4857.

PUBLISHED WEEKLY. ENTERED AS SECOND
CLASS MATTER AT NEW YORK, N.Y.

Subscription Rates :
Home and Canada, £1 10s. 4d. ; other
countries, £1 12s. 6d. per annum.

*As many of the circuits and apparatus described in these
pages are covered by patents, readers are advised, before
making use of them, to satisfy themselves that they would
not be infringing patents.*

CONTENTS

	Page
Editorial Comment	407
Auto Transformers	408
Single-knob Sensitivity Adjustment	410
Frequency Modulation Again ..	411
Cheap Valve Voltmeter	413
The Radio Compass	414
Television Programmes	416
Modern Insulating Materials—II	417
News of the Week	419
Murphy Television Receiver A56V:	
Test Report	422
Aircraft Wireless	424
Television Topics : Linear Saw-	
tooth Oscillator	425
Unbiased	426
The AVC Characteristic	427
Random Radiations	428
Recent Inventions.. ..	430

EDITORIAL COMMENT

Wire or Wireless ?

Feeding the Television Relays

IT would appear that the Radio Manufacturers' Association's offer to bear any financial loss consequent on extension of the television service to the Birmingham area has been generally misunderstood. In a supplementary statement subsequently issued by the Association the details are elaborated, and it is made clear that the offer is confined to reimbursing those concerned for the cost, in the event of the experiment proving unsuccessful, of a wireless link for supplying the proposed Midland transmitter with modulation from the London television headquarters.

It is rightly stressed in the R.M.A. statement that the transmitting station itself will in any case be required sooner or later, and so there is no real excuse for delay in beginning construction. The transmitter that would be built can in no sense of the word be described as experimental, and it would be equally suitable for operating with picture signals supplied either by co-axial cable or a radio link.

Sir Noel Ashbridge, Chief Engineer of the B.B.C., has expressed himself publicly as being in favour of cables for television extensions, as he considers that they provide a neater and more workmanlike solution of the problem, and, above all, one that does not occupy valuable space in the ether. Although it may sound like heresy to admit it in a wireless journal, this is an opinion with which one cannot disagree, at any rate as applied to the permanent system that will, we may be sure, eventually supply the whole of this country with a television service. But for experimental extensions in the early stages the wireless link seems to

have much in its favour ; its cost is considerably less than that of a cable and it is certainly more flexible.

In the opinion of the technical advisers of the R.M.A. there are no unsurmountable obstacles to the use of wireless, and this opinion is endorsed by Mr. Ralph R. Beal, Research Director of the Radio Corporation of America, who recently said : " R.C.A. engineers are confident that American cities will be linked by means of automatic radio relays, employing ultra-high frequencies. The practicability of such relays has been proved by exhaustive experiments."

If this country is to retain the lead it has gained something must be done quickly, and, from this point of view, the outstanding attraction of the wireless method of distribution is that it can be installed more quickly than cables.

Battery Portables

The "All-dry-cell" Type

ALTHOUGH America was slow in taking up the self-contained battery-fed portable receiver, she has, in one important detail, made amends for her tardiness. As described by a correspondent on another page, the latest American portables are equipped with dry-cell low-tension batteries.

We have for some time urged the use of this form of LT supply for broadcast receivers—and other apparatus—that is intended solely for intermittent and occasional use. Of course, over long periods of operation the accumulator remains the most effective and by far the most economical source of current, in spite of the improvement that has taken place in the better type of dry cell.

Auto Transformers

THEIR OPERATION EXPLAINED

By N. PARTRIDGE

THE auto transformer is a much maligned piece of apparatus. When recommending such an instrument, it is not at all unusual to be met by the retort: "Oh, I want a proper transformer, not a tapped choke." Remarks of this sort are nothing short of libellous. Not only is the auto directly descended from the greatly respected double-wound transformer, but it is an amazingly energetic offspring. It will handle more power, weight for weight, than its revered ancestor could contem-

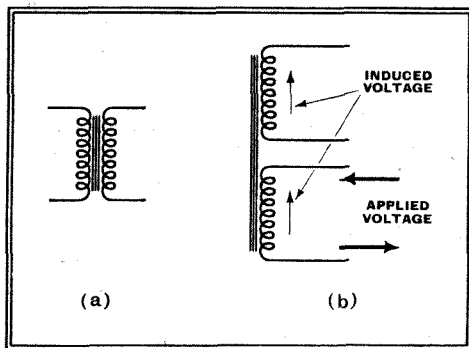

Fig. 1.—Two ways of symbolising a double-wound transformer; (a) is the more usual way but that of (b) serves better to follow the explanation given in the text.

plate without acquiring a feverish temperature and other symptoms of distress.

Fig. 1(a) shows the usual diagram representing a double-wound transformer. In order to make the ensuing discussion more readily understandable, we will redraw it in the form of Fig. 1(b). There is no reason why both windings should not be drawn on the same side of the core, and this proceeding involves less mental readjustment when we join the windings together and thus make an auto of it.

Suppose the primary, which we will assume is the lower winding in the diagram, is rated at, say, 100 v., 1 a., i.e., 100 watts. The DC resistance of this winding would be a matter of only 2 to 3 ohms. Yet, when 100 v. AC is applied (the secondary remaining open circuited) only quite a small current flows. On the face of it, Ohm's Law appears to be in error!

The explanation is that as soon as an alternating current passes round a coil it sets up an alternating magnetic flux in the iron core of the transformer. This in turn induces an opposing voltage in the coil which tends to prevent current from flowing. The state of affairs can be pictured by looking at the arrows in Fig. 1(b). The heavy external arrows indicate the applied voltage at any instant, while the

light arrow suggests the internally generated voltage. These two are pushing in reverse directions and almost cancel each other. The induced EMF is always slightly smaller than the applied voltage owing to losses and the inefficiency of the magnetic circuit, and, therefore, a small no-load current flows from the external supply.

It is not necessary for the reader to worry about the technicalities of how all these things come to pass, but it is extremely important to thoroughly understand that an opposing voltage is generated within the winding, and that it is this voltage that prevents a heavy current from flowing.

Since both the windings on our imaginary transformer are wound upon the same magnetic core, it is reasonable to expect that if a voltage is induced in one it will also be induced in the other. Such, indeed, is the case, as the application of a voltmeter to the open-circuited coil will readily prove. The induced voltage is found experimentally (and can be proved theoretically) to be proportional to the number of turns on the coil. In other words, a definite voltage is induced in each turn of the winding, and the total voltage exhibited by the coil will be the voltage per turn multiplied by the number of turns.

When the mains are applied to the primary of a transformer, everybody

Fig. 2.—The induced secondary current in a double-wound transformer flows in the opposite direction to the primary current.

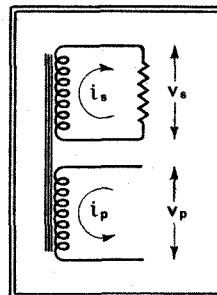

knows that the various secondaries become "alive." But we have just discovered a vital point that normal experience does not reveal, namely, the direction of the voltage. The induced EMF in the secondary is always in the reverse sense to that of the voltage applied to the primary. If the secondary circuit be completed through a suitable load, current will flow through the winding in such a direction as to oppose the magnetising effect of the small no-load primary current. As soon as this occurs the back voltage in the primary falls and the primary current consequently increases (see Fig. 2).

Were this a serial story it would be a suitable moment to terminate the episode at this juncture, with the secondary doing its best to demagnetise the core, and the

THE main features of an auto transformer are explained in this article and it is then shown that a considerable saving in cost can be effected when conditions permit the use of components of this kind.

primary speedily drawing excess current in a desperate effort to hold its own. However, the sequel must be divulged at once and, as is not unusual with these things, it is somewhat disappointing. The invariable result of the struggle is a draw. The excess primary current ends up by exactly balancing the demagnetising effect of the secondary current, and the small initial primary current that flowed in the no-load condition continues its monotonous occupation of producing an alternating magnetic flux in the core.

Primary Current

It will be noted that the primary current (on load) consists of two parts. Namely, the magnetising or no-load current and the load current. The former is only a small percentage of the latter in a well-designed component, and can be left out of one's calculations so long as its presence is not entirely forgotten. Henceforth we will ignore its existence.

The magnetising effect of a current passing round a coil is proportional to the current multiplied by the number of turns in the coil. Since, under load, primary and secondary always balance one another magnetically, it follows that

$$i_p T_p = i_s T_s \dots \dots (1)$$

where T_p and T_s are the turns on the primary and secondary windings, and i_p and i_s are the corresponding currents. It has already been stated that the voltages of the windings are proportional to the turns and, therefore, it follows that

$$i_p v_p = i_s v_s \dots \dots (2)$$

which is to say that the watts put into the primary equal the watts going out of the secondary. This condition would be substantiated if iron and copper losses were

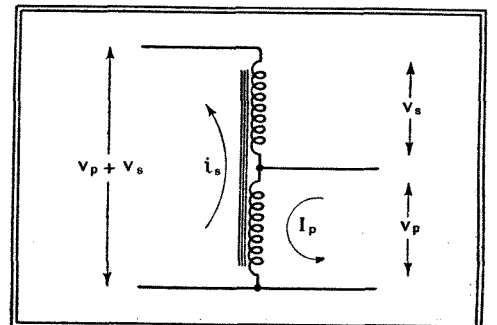

Fig. 3.—By connecting primary and secondary in series it becomes an auto transformer.

Auto Transformers—

non-existent, and it is approximately true in practical experience if the transformer is a good one.

Having understood the general principles of transformer action, it is easy to grasp what occurs when the windings are auto connected. Fig. 3 shows the transformer of Fig. 2, arranged in auto fashion with v_p and v_s the original primary and secondary voltages. Under the new scheme the total output voltage becomes $(v_p + v_s)$ since the windings are joined together with their induced voltages in the same sense. I_p and i_s represent the load current drawn from the mains and that passing through the secondary load. Note carefully that I_p is the current drawn from the mains and not necessarily the current passing through the primary section of the winding.

Current in Auto Transformer

A critical examination of Fig. 3 will reveal that while the upper section of the winding, i.e., the original secondary, carries the secondary load current (i_s), the lower section, i.e., the original primary, carries both the input load current (I_p) and also the secondary current (i_s). These two currents are in reverse directions and the true current passing through the conductors of the primary winding is $(I_p - i_s)$. If we can show that $(I_p - i_s) = i_p$ the transformer will function quite happily because the currents carried by the upper and lower

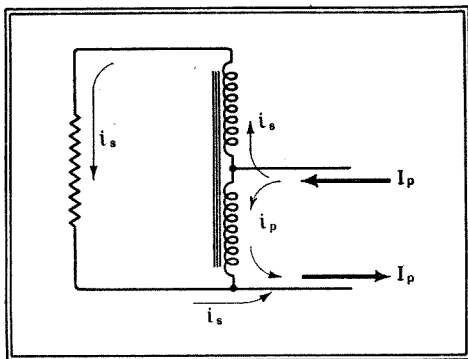

Fig. 4.—The current flow and voltages in an auto transformer are shown here.

sections of the winding will be the same as they were originally, although the output has been increased from $i_s v_s$ to $i_s (v_p + v_s)$ watts.

The proof is not very difficult. For a condition of equilibrium we know that a state of "magnetic balance" must exist between the two sections of the winding. The demagnetising effect of the secondary is proportional to $i_s T_s$ and the magnetising effect of the primary is $(I_p - i_s) T_p$. It follows that

$$i_s T_s = (I_p - i_s) T_p \dots\dots\dots (3)$$

Earlier it was shown that "magnetic balance" resulted when $i_p T_p$ equalled $i_s T_s$ (see equation 1). Thus by substituting in equation (3) we conclude that

$$i_p T_p = (I_p - i_s) T_p$$

and if both sides are now divided by T_p we achieve our object by proving that:—

$$i_p = I_p - i_s \dots\dots\dots (4)$$

A common sense method of visualising

what happens without fussing around with algebraical symbols is illustrated in Fig. 4. The load current drawn from the mains (I_p) splits into two parts when it reaches the transformer at the junction of the two windings. One part turns to the right and becomes the secondary load current (i_s), while the remaining part (i_p) goes to the left through the lower or primary winding. Hence $i_p = I_p - i_s$ as before. These two currents, i_p and i_s having completed their various journeyings, link up again on

wound. Note that when the transformation ratio is 2 : 1 the current through both sections of the winding is the same, and hence the same gauge of wire can be used throughout. This is the practice adopted for autos designed to operate between the 100 to 120 V and the 200 to 250 V ranges.

Example 3.—Input 230 V, output 4 V, 40 watts.

The input current is 40 divided by 230, which is 0.174 amp., and the output current is 10 amps. ($40 \div 4$). The current

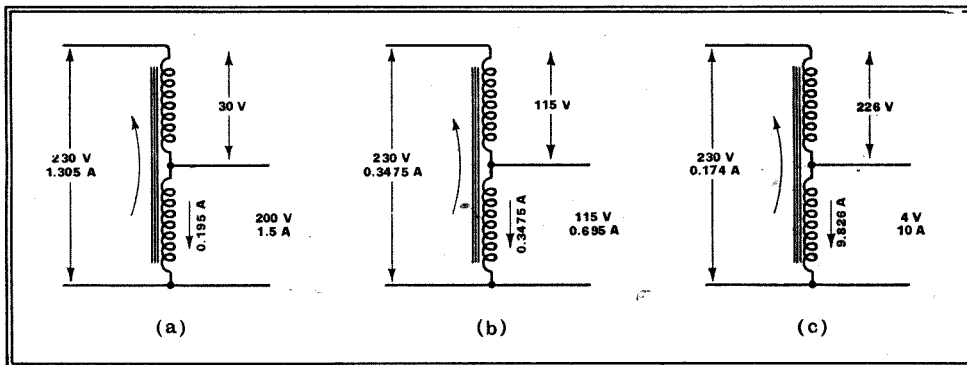

Fig. 5.—Three examples of auto transformer; the method of calculating current distribution is explained in the text.

leaving the transformer and proceed home to the local power station as one (I_p).

Having elucidated the problem of how an auto works, the solution should not be discarded in the manner of a finished crossword puzzle. The fact that i_p equals $I_p - i_s$ can be extremely useful and transformer manufacturers who know about it can often save a lot of money by its conscientious application. A few examples will make this clear.

Example 1.—Input voltage 200 V, output 230 V; 300 watts. The input current will be 300 divided by 200 which equals 1.5 amps, and the output current is 300 divided by 230 which equals 1.305 A. Current through the common portion of the winding becomes $1.5 - 1.305 = 0.195$ amp. (see Fig. 5 (a)). The apparent wattage of each section of the winding is: $200 \times 0.195 = 30 \times 1.305 = 39$ watts.

It follows that this 300-watt auto transformer could be assembled on a core that would accommodate only 40 watts if double-wound.

Example 2.—Input voltage 115V; output 230 V, 80 watts.

The input current will be 80 divided by 115 = 0.695 amp., and the output current 80 divided by 230 = 0.3475 amp. Current through the common portion of the winding becomes $0.695 - 0.3475 = 0.3475$ amp. (see Fig. 5 (b)). The apparent wattage of each section of the winding is: $115 \times 0.3475 = 115 \times 0.3475 = 40$ watts.

Again the core required will be one capable of handling 40 watts when double

through the common portion of the winding is therefore $10 - 0.174 = 9.826$ amps., and the apparent wattage of each portion of the winding is:—

$$226 \times 0.174 = 4 \times 9.826 = 40 \text{ (approx.)}$$

It is evident from the above calculations that the saving is greatest when the input and output voltages are of the same order, i.e. when the transformation ratio approaches unity. In fact, when the ratio is unity the transformer vanishes and is not wanted at all whatever the power! At the other end of the scale, Example 3 indicates that little advantage is to be gained by auto connecting when the ratio is large. A point that might well be mentioned here is that for the purpose of preliminary calculations it does not matter which way the auto transformer is working, i.e. stepping up or down. This will influence only the

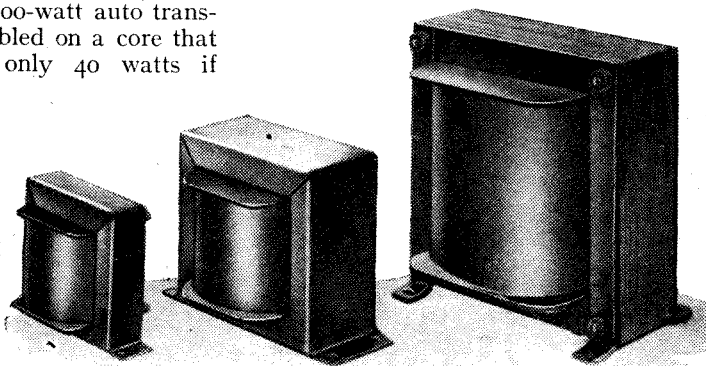

Fig. 6.—All these transformers handle the same wattage but the smallest and medium-size models are auto-wound. The largest weighs 29½ lb., the medium-size one 12 lb. and the smallest 3¼ lb.

small allowance that should be made in the final design for the voltage dropped in the windings.

The photograph shown in Fig. 6 brings out in a striking manner the economy that can be effected by the use of properly de-

Auto Transformers—

signed auto transformers. Each of the three transformers illustrated is rated at 500 watts and the complete electrical de-

The reader can verify his understanding of the foregoing by calculating from the information given in Fig. 7 what wattage could be accommodated on the two smaller

knob in an anti-clockwise direction the spindle B moves towards minimum, and at a point near minimum the pin P enters the slot S. Spindle A then starts to move. This is only possible due to the fact that the cam face C at this point ceases to lock with cam D, as indicated at (b). In diagram (c) spindle B has moved nearer to minimum and spindle A has completed half its travel. At the point when the pin is about to leave the end of the slot, spindles A and B have both reached minimum. Throughout these movements both spindles remain interlocked either by the slot and pin or the cam surfaces, and stops at minimum and maximum of control B prevent the pin P from leaving the slot S.

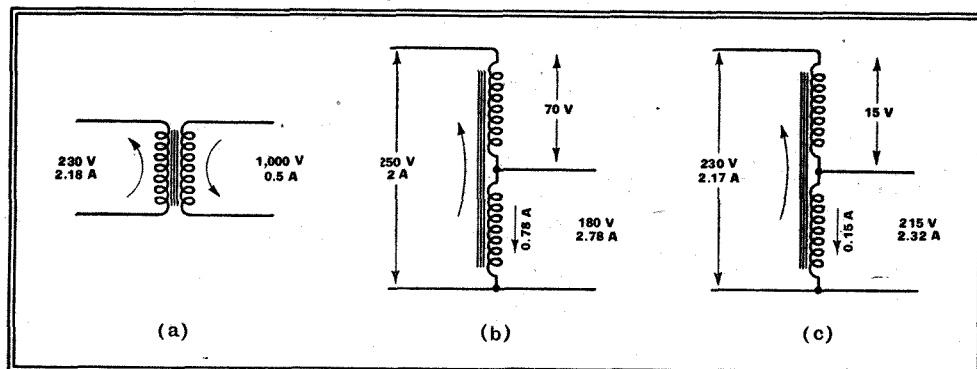

Fig. 7.—Voltages and currents of the three transformers illustrated in Fig. 6 (a) the large model, (b) the medium-size one and (c) the smallest.

tails are indicated in Fig. 7. Were the two smaller items double wound they would have been the same size as the large one.

transformers if they were double wound. The answer is approximately 140 and 33 watts.

Single-knob Sensitivity Adjustment

COUPLING DEVICE FOR CONTROL SPINDLES

IT is nearly always found necessary to provide two controls for simple TRF receivers to enable, on the one hand, excessive input from strong local transmitters to be cut down, and, on the other, to provide adequate sensitivity for the reception of very weak stations.

In the interests of simplicity, it is highly desirable that these two controls should be operated from the same knob. This can be achieved by means of:—

- (1) a three-electrode differential condenser;
- (2) a tapped potentiometer;
- (3) concentric knobs;
- (4) two controls ganged together.

Methods (1) and (2) have various technical disadvantages, and method (3) is not a complete solution. Method (4) may have the following disadvantages:—

- (a) Undue space may be taken up in attempting to couple two standard components.
- (b) To overcome disadvantage (a) it will be necessary to design special controls having a common spindle.
- (c) Unless components of special design are used both controls will operate simultaneously, whereas it is desirable that one should complete its travel before the second comes into effect. Further, the second should be brought near zero before the first commences to reduce the input.

A mechanism has been evolved which overcomes these three difficulties. It is simple in operation and takes up very little space.

It couples two spindles, mounted in parallel planes, in such a manner that the

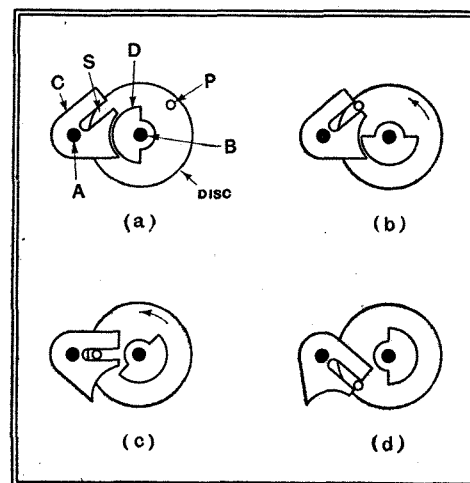

Showing different stages in the operation of the coupling mechanism described in the text. The coupling would be suitable for linking, say, an RF gain potentiometer and a reaction condenser in a simple "straight" receiver.

first control moves to maximum before the second advances considerably, and remains at maximum while the second continues on its travel towards maximum. On returning the second control to minimum the first control does not start to decrease until the second has almost reached a minimum value itself. The mechanism is shown in the accompanying sketch in four positions in order to make clear the principle of operation.

The two controls have spindles A and B respectively. On spindle A a cam is mounted, having a slot S. On spindle B a cam and disc are mounted. A pin P is fixed to the disc. The knob is mounted on the spindle B. At (a) both controls are shown at maximum. On rotating the

PROBLEM CORNER—18

An extract from Henry Farrad's correspondence, published to give readers an opportunity of testing their own powers of deduction:—

All Hallows School,
Berkhamssted.

Dear Henry,

During the hols. my people were having a refrigerator put in ready for the summer, and as it made quite a row in the domestic radio I thought I would have a shot at suppressing it. I wanted to use the smallest coils possible, but the current-carrying capacity question then arose. As I haven't an AC ammeter I tried working it out from the house meter, and although the coils I got should be all right I find they get quite hot. Would you mind checking over my line of thought, because I can't see anything wrong with it?

The meter is marked "900 revs per kWh," and the voltage is 240. When the fridge is on (and nothing else) it does two revs in exactly one minute. That would be 120 revs in an hour, so the watts ought to be $\frac{1,000 \times 120}{900}$, which I think is just over 133.

So the current ought to be $\frac{133}{240}$, which I make to be 0.55 amp. Seeing that the thing doesn't run continuously I should have thought coils advertised to carry half an amp would have been quite good enough, wouldn't you? Or have I slipped up somewhere?

Yours ever,
Tony.

Has he? And, if so, where? Turn to page 416.

"The Wireless Engineer"

THE properties and advantages of a new "all-glass" valve construction are given in the May issue of *The Wireless Engineer*, which is published at 2s. 6d. and is obtainable from booksellers or from the Publishers, Dorset House, Stamford Street, London, S.E.1. Among other articles in this issue is one in which the input impedance of self-biased amplifiers is discussed.

Editorial comment is made on an apparatus recently introduced in Germany for the direct measurement of the "quality" of coils. A monthly feature of *The Wireless Engineer* is the Abstracts and References section, compiled by the Radio Research Board, in which is given abstracts of the articles on wireless and allied subjects published in the World's technical press.

Frequency Modulation

ANTI-NOISE BROADCASTING AND HOW IT WORKS

Again

TWO years ago¹ I had something to say about the Armstrong frequency modulation system. It was not new even then, but it is only in the last month or two that it has attained the supreme rank of "front-page stuff," as the lay Press has it. I am not now attempting to compete with the well-known organs of journalism in the matter of picturesqueness of description or the wealth of imagination with which they decorate these highly technical matters, but perhaps the tendency for this enthusiasm to lead to a loss of proportion needs some corrective. For example, the solution of some great technical problem that has exercised the minds of the experts for a generation is much more likely to qualify for the status of "front-page stuff" if an unimportant by-product of the thing happens to cause tabby cats to turn light blue and refuse fish. To appreciate the really important features of a technical achievement it is generally necessary to know something about the subject, and the lay writer suffers from the handicap of being unable to assume even the desire for knowledge except of the most superficial kind.

The Basic Problem

My readers, on the other hand, probably know already that the problem in radio nowadays is not so much how to get the "signal" across as how to exclude "noise." "Noise" in this sense means interference due to a great variety of causes—atmospherics, disturbances caused by electrical appliances, other stations, valve and circuit fluctuations, and so on. It isn't an ideal term, I know, but the American "static" is far worse (*static* means "at rest"). Put concisely, signal/noise ratio is more important than signal strength. If it were not for noise, the range of even a low-power transmitting station would be almost unlimited. If

you have ever worked an extremely—one might perhaps say *excessively*—sensitive receiver you will have realised that almost every station in the world can be brought in, but only a few of them are worth having. On a thundery day it may be that only the local station is clear of noise; perhaps not even the local station.

Hitherto, the method of tackling this problem has been to use brute force. The power of the largest broadcasting stations, which used to be $1\frac{1}{2}$ kW, has gone up in turn to 5, 10, 25, 50, 100, 120, 150, and even 500, in the attempt to keep above the rising flood of noise. Of course, this tends to increase the interference trouble. Already one of the 500 kW fellows—Cincinnati — has been told to come down to a more reasonable level.

The main object of frequency modulation is to cut through the noise without excessive power. It has been demonstrated that a frequency modulation station of, say, 1 kW, gives as good a service as an amplitude modulation station of perhaps 20 kW or more. Why? Well, it is not at all easy to see exactly, but some idea can be got by considering how "noise" affects a receiver of the ordinary type. Looking at Fig. 1, (a) shows a typical sample of the waveform received from a broadcasting station. The sound is conveyed by variations in the *amplitude* of the carrier wave; in other words, it is amplitude-modulated. Most of the noises have waveforms something like (b); often much stronger than the transmitter's wave, but very short-lived. The effect of these sudden blows is to jerk the tuned circuits of the receiver into oscillation at whichever frequency they are tuned. The signal amplitude is therefore disturbed, and besides the broadcast programme one hears crackles and bangs.

Now contrast the reception of a frequency-modulated station. The receiver is of a special design, and is arranged to be unresponsive to variations in amplitude. So ordinary stations and noise are not heard. At least, not nearly so much.

The transmitter sends out a carrier wave of constant strength, and the sound is imposed on it by causing its frequency to vary to and fro around the normal frequency. The receiver is designed to translate these frequency variations back into sound.

That is a very rough and ready explanation.

By "CATHODE RAY"

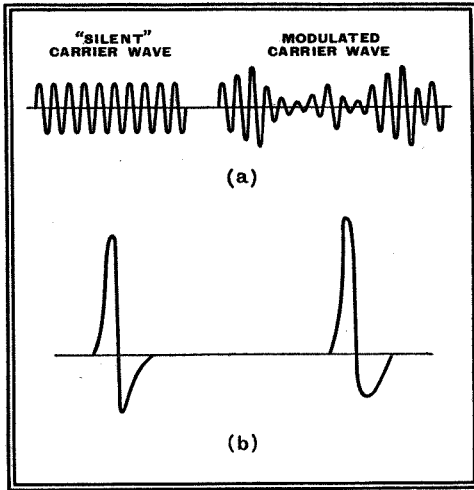

Fig. 1.—The waveforms of (a), an ordinary broadcasting station and (b) noise.

tion. Actually, there is very much more in Armstrong's system. It would be possible theoretically to convey a programme with only a small variation in frequency, but the discrimination against noise would then be small, too. To get the full benefit of the method the frequency is made to vary over a wide band—about 60,000 cycles each side of normal. That covers the space allotted to about a dozen ordinary broadcasting stations, so a frequency-modulated station has to be treated like a television station and pushed into the ultra-short wave department where a hundred kilocycles or so doesn't matter very much.

The Methods Compared

Those who have forgotten my previous article on frequency modulation, or never read it, may be a bit confused about the difference between these two methods of modulation, knowing that the common or amplitude modulation system also covers a band of frequencies. That is quite true. Any elementary textbook on radio explains how a variation in amplitude of a constant-frequency wave, as shown in Fig. 1 (a), is equivalent to the combination of a constant amplitude wave and waves of slightly different frequencies (the "sidebands"). But here is the distinction—in such a system the difference in

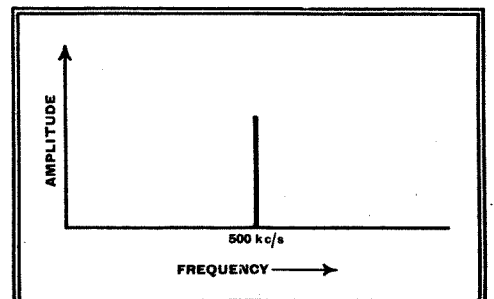

Fig. 2.—Amplitude/frequency diagram of a silent carrier wave transmitting at 500 kc/s.

¹ "Noise," January 15th, 1937.

"Frequency Modulation," July 16th, 1937.

Frequency Modulation Again—

frequency between the original carrier frequency and these sidebands is fixed by the frequency of the modulation; whereas in frequency modulation the frequency of the carrier wave itself fluctuates, to an extent that has nothing to do with the frequency of the modulation. It sounds very confusing in words, I'm afraid, but the idea is easy to grasp from simple diagrams representing the result of broadcasting a 1,000-cycle tuning note on a 500-kc carrier wave. In either system the unmodulated carrier wave would be represented as in Fig. 2—a single fixed frequency. In the common AM system the effect of varying the amplitude at a frequency of 1,000 c/s is to produce two more waves, differing 1,000 c/s from the carrier (Fig. 3). A strong sound is shown by (a), a weak one by (b). In FM the frequency of the carrier is varied to and fro 1,000 times a second (Fig. 4). The extent of the variation corresponds to the strength of the sound, so strong and weak are again shown by (a) and (b) respectively. Suppose now that the frequency of the modulation—that is to say, of the sound that is heard—is raised to 2,000 c/s; the effect in Fig. 3 is that the two outside vertical lines spread out twice as far from the centre line, whereas in Fig. 4 there is no visible change, but the line has to be imagined to vibrate to and fro twice as many times per second.

The above simple explanation is rather misleading, because it would lead one to suppose that a frequency-modulated

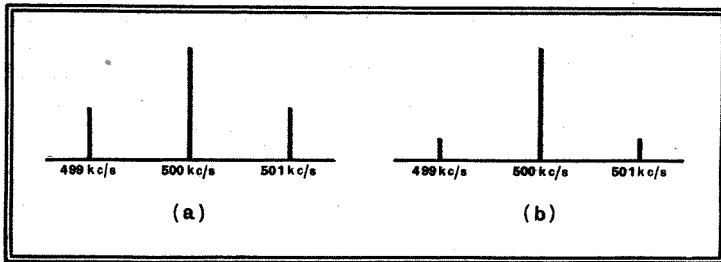

Fig. 3.—The same carrier wave as in Fig. 2 when modulated by a 1,000 c/s note, (a) strong, (b) weak.

station could be made to operate within a narrower band of frequencies than an A-M station. In fact, even the experts thought so at one time, until a certain Mr. Carson proved mathematically that the frequency band covered by a transmitter could never be less than twice the greatest modulation frequency; which put a permanent end to hopes of packing stations closer together in the frequency scale. However, that is not what Armstrong was after.

High-Power Tests

In his most recent demonstrations he used two ultra-short wave transmitters; one high-power station, 40 kW on 42.8 Mc/s (just about half-way between the Alexandra Palace sound and vision frequencies), and a low-power station, 0.6 kW, on the still higher frequency of 110 Mc/s (about $2\frac{3}{4}$ metres). The first ought to be pretty good, of course, being of far

higher power than any other ultra-short wave station in the world, though less than the average medium-wave "main" broadcasting station; and it has been received consistently at 275 miles distance. But at 50 miles even the low-power station gives results better than ordinary broadcasting stations a hundred times more powerful, at the same distance, the superiority being more marked the worse the conditions of noise prevailing at the receiving station.

Another advantage is that there is a further saving at the transmitter due to the very nature of the modulation. As the amplitude is kept constant the transmitter does not have to be designed to cope with the peaks of amplitude that occur in amplitude modulation, and which for a given average radiated power necessitate far larger and more expensive valves, power plant, etc. Then, for the same reason—constancy of amplitude—there is no objection to the use of "Class C" amplification in the output stage of the transmitter, giving a higher power efficiency than the methods that are generally necessary for really high quality in amplitude modulation. Still another point in favour of FM, so far as the transmitter is concerned, is that no drastic results follow if there is accidental

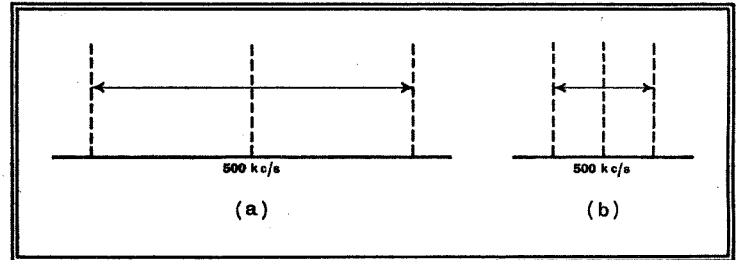

Fig. 4.—Diagrams, corresponding to Fig. 3, for a frequency modulation transmitter.

over-modulation. With the AM transmitters the control engineers have to be extremely vigilant in preventing the audio signal supplied to the transmitter for modulation from exceeding a certain amount. Not only would it cause distortion, but it might

lead to serious and expensive damage and breakdown. In a demonstration of the Armstrong system the modulation was increased up to nearly six times the normal limits, and there was not even noticeable distortion up to three times. Much smaller increases would be absolutely fatal in AM.

On the other side of the balance sheet, the system is far more complicated, and about 50 valves are used in the preliminary stages. That may sound a lot, but remember the 1,079-valve receiver I referred to a few weeks ago. And, although they are at the transmitting end, these preliminary valves can be small receiving types, and it would not be uneconomical to duplicate the whole system for guarding against breakdown. The original oscillation is at 200 kc/s (same as Droitwich long-wave station); and modulation is introduced at this stage, producing a small shift in phase, that is to say, a fraction of each cycle. The carrier fre-

quency is then multiplied time after time till it reaches 12,800 kc/s; it is whisked back to 891.6 kc/s by a frequency-changer stage as in a superhet; and then multiplied again until it reaches the final 42,800 kc/s. By the time all this has been done the modulation is 120,000 c/s wide (60,000 each side of normal). Then the power is amplified in several stages up to the full output.

At the receiver there is no constructional

advantage; in fact, it seems inevitable that it must be rather more complicated and costly than an AM receiver. From information available, however, it does not look as if the extra cost need be out of proportion to the increase in performance. This advantage in performance consists, first, as I said, of cutting out most of the noise. Listeners at the demonstrations were greatly impressed by the dead quiet background. The other thing that impressed them was the extremely high fidelity of the reproduction. This was made possible by working in the ultra-short waveband, allowing frequencies up to 15,000 c/s without the interference that would be inevitable at 50-mile range in the medium band. Of course, that is no monopoly of frequency modulation; any ultra-short wave station can be allowed to spread enough to take in the highest programme frequencies. But, with AM, the wider the band the more liable to noise,

Our cover illustration shows the aerial tower of Major Armstrong's experimental frequency-modulated station at Alpine, New Jersey. The radiating system, relatively insignificant in size as compared with the tower, can just be seen between the extremities of the upper and intermediate arms.

whereas the opposite applies to FM of the Armstrong brand; and a lot of the naturalness of reproduction was stated to be due to the complete absence of background. So FM can be said to improve the quality actually attainable under working conditions at a distance from the transmitter.

The one type of interference that has been found to break through—though much less badly than with AM—is car ignition, because, as ill-luck would have it, this is the type of interference that FM is least effective against, as well as being by far the most vicious on USW.

Well, it would be very nice to have some FM stations for the quality merchants to practise on, but the B.B.C. will have their hands full for some time to come develop-

Frequency Modulation Again—
ing the television service, and are not likely to put up stations that would be of no use to existing receivers. On the other hand, it seems hardly likely that such a worked-out invention will be allowed to lapse. One must certainly congratulate Armstrong and his co-workers on their achievement in the face of all previous

theoretical assumptions and established precedent.

By the way, seeing that the Alexandra Palace station is systematically received in U.S.A., is it not time that somebody reported the much more powerful Armstrong station over here? Given a suitable receiver, the FM characteristics ought to give good reception.

Cheap Valve Voltmeter

SIMPLE WIDE-RANGE MEASURING INSTRUMENT
USING A DIODE

TO the serious experimenter, a valve voltmeter of fairly wide voltage range and reasonable accuracy is a very necessary instrument. It has an enormous number of uses, for both audio- and radio-frequency measurements. Unfortunately, many voltmeters of a suitable type are expensive. With a view to producing a valve voltmeter of sufficient accuracy for the normal needs of the experimenter, and which may be easily constructed and calibrated, the instrument described below has been designed.

Perhaps the simplest voltmeter to construct is the leaky grid or anode-bend triode type. The anode current, or rather the change in anode current, is a measure of the AC voltage applied to the grid of the triode and usually this involves the use of a calibration chart or curve. Anyone who has used this type of meter knows that, although great accuracy can be obtained, the calibration curve can be a great nuisance and unless permanently fastened to the meter in some way, has a nasty habit of getting lost. In any event if great accuracy is not required and speed is important a direct reading meter saves a great deal of time.

The writers, therefore, have overcome these difficulties by designing a meter, having a reasonable input impedance, with which any alternating voltage from between 1 volt to 300 volts can be easily read directly on the scale of the meter.

To make the instrument as simple as

possible a 2-volt triode is used connected as a diode. A diode of the type used for rectification in superheterodynes, or for supplying AVC was not used, as it was found that the zero space current is too high.

The most expensive item in all instruments of this type is usually the meter used to read the current flowing through the diode. To obtain a fairly wide range at a reasonably high input impedance it

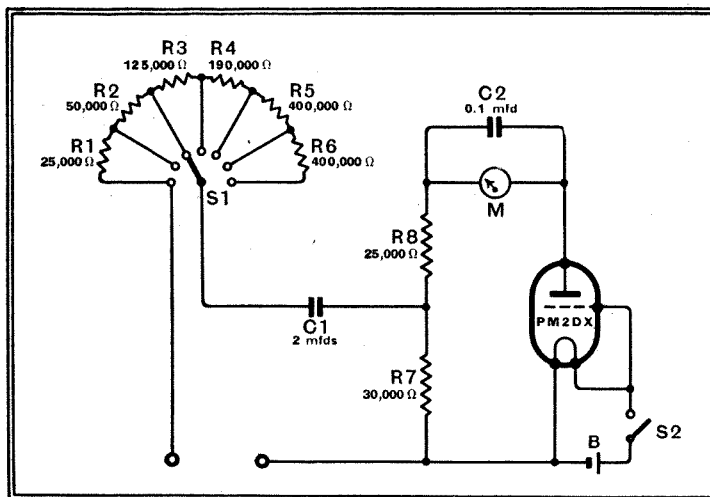

Fig. 1.—The voltmeter itself is of fixed range and a wide variety of input voltages is catered for by the input potentiometer, which is controlled by the 7-way switch S1.

was decided to use a meter having a maximum reading of 50 microamperes.

The particular instrument used is

The underside of the panel is shown here together with the LT accumulator.



An exterior view of the instrument.

obtainable at a low price and has the required accuracy; it is a Leslie Dixon 0-50 microammeter. The circuit diagram of the voltmeter is shown in Fig. 1 and the photographs show the completed instrument. It will be seen that it is self-contained and very compact.

A Mullard Type PM2DX valve is used, but any valve having similar characteristics may, of course, be employed. It will be noted from an examination of Fig. 1 that the control grid is connected to the positive end of the filament. This is done to reduce the standing space current. It was found that with the grid connected to the anode the space current was about 5 microamps, but with the connections as shown this value dropped to about 1 microamp.

The ranges of the meter illustrated are as follows: 5, 10, 20, 50, 100, 200, 300 volts maximum, using a seven position switch, but these may, of course, be altered to suit individual requirements. As the meter is scaled 0-50, no calibration curve is necessary and the voltage reading is obtained by multiplying by a simple factor. It was found that the readings were accurate to about plus or minus 5 per cent. using standard resistances.

Calibration, that is to say, checking the accuracy of the ranges, was carried out at 50 c/s using an Avometer, and it is felt that this is probably the best method.

The frequency characteristic of the instrument is good and the writers feel confident that in view of its extreme simplicity the time and money spent on its construction will be well repaid.

Apart from the general uses at radio-frequency the meter is suitable for all audio-frequency work and, of course, for checking valve heater voltages.

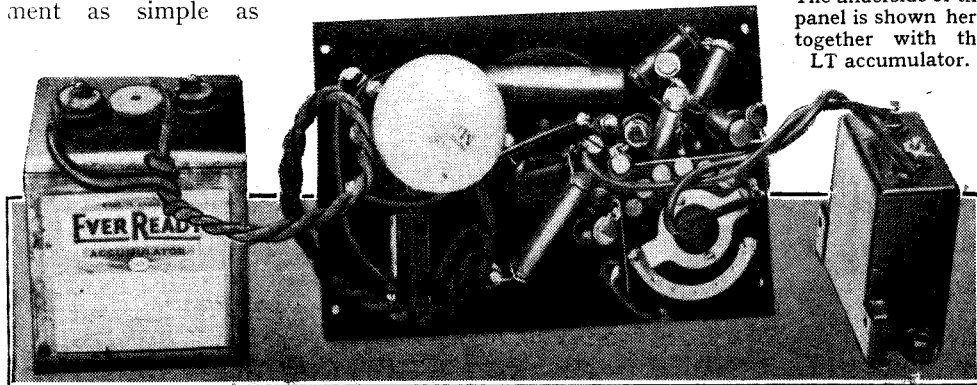

The Radio Compass

AN expression which has been used rather freely to describe any automatic method of direction-finding which claimed to be an improvement on the ordinary frame aerial appears at the head of this article. It was applied, for instance, to the early rotating beam transmitter which radiated first a "start" signal and then a timed sequence of impulses at successive points of the compass, so that a distant navigator could ascertain his bearings with the help of a stop-watch. As far back as 1920, the U.S.A.

Navy installed a receiving set which was officially called a radio-compass though, in fact, it was little more than a convenient form of the well-known frame-and-open-aerial combination that has the merit of indicating "sense" as well as direction.

More recently directional systems have been developed in which two overlapping beams (one modulated with dots and the other with dashes) mark out a definite path or "guideway" for air navigation. The machine is flown along the centre line of overlap, where the dots and dashes merge into a sustained or unbroken note. At first the pilot had to depend upon a pair of headphones to distinguish the

Elaborations of the Direction-finder Principle

starboard "dots" and the port "dashes" from the continuous note which told him he was keeping on his proper course. Subsequently, the headphones were replaced by visual indicators which showed him automatically the extent and direction of any deviation from the straight path. This kind of installation—also known as a radio-compass—is representative of the more modern type of instrument, which is usually designed for work in the air where quick results and automatic action are of the first importance.

Generally, it consists of a small frame aerial maintained in constant rotation at a speed sufficiently high to keep the indicator steady, whether the latter is a centre-zero meter possessing a certain amount of inertia, or a cathode-ray tube depending on

Fig. 1.—Simplified diagram of a single-frame radio compass.

a persistence-of-vision effect. In some cases the aerial is positively driven, whilst in others the effect of physical rotation is secured by a method of switching which leaves the aerial stationary.

When a single frame aerial is constantly rotated, at a speed of, say, five revolutions a second, the received signal strength rises to a maximum each time the plane of the aerial cuts across the line of the distant transmitter; this will occur twice in the course of each complete

DESCRIBING the principles of operation of specialised direction-finding instruments, largely used on aircraft, in which visual or aural indication of bearing (or deviation from course) is given more or less automatically and without the usual "searching" process.

revolution. Similarly, there are two points of minimum signal strength, where the phase of the pick-up is also reversed. The resulting current is therefore sinusoidal, with a low-frequency "amplitude" variation of 10 cycles a second, and so long as the machine keeps on a straight course towards the transmitter, the maxima and minima will always repeat themselves at the same points on the circle of rotation. In other words, both the frequency and phase of the signal current remain constant.

But if the machine changes course the point in the circle of rotation at which the aerial picks up maximum signal strength will follow suit. That is to say, the phase

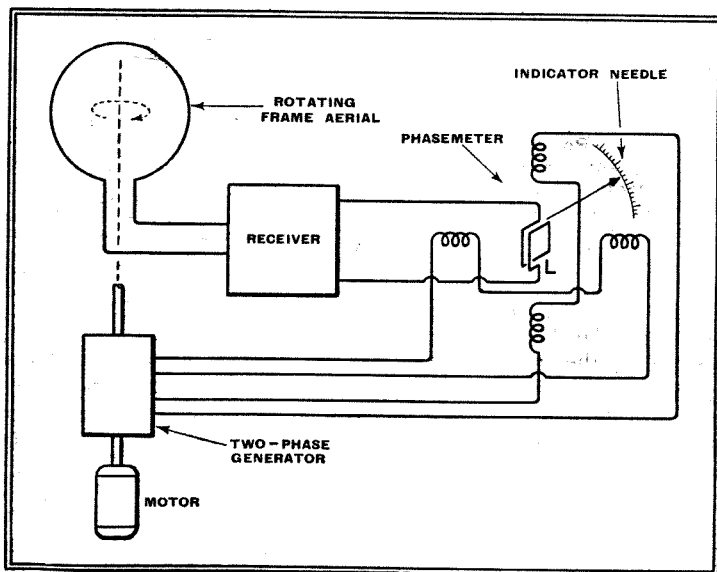

of the pick-up current shifts by an amount which depends upon the change in direction. This phase-shift, which can be measured by comparison with a second current of constant frequency and unvarying phase, then gives a direct indication of the new bearing of the distant transmitter.

As shown in Fig. 1, the frame aerial is driven by a motor through reduction gearing, and the local "reference" current is supplied from a two-phase motor mounted on the same spindle. After the phase of the reference current has been centred about the fore-and-aft line of the machine it is supplied to the field coils of the phase-meter or indicator, whilst the pick-up current from the aerial is fed through the receiver into the pivoted search coil L.

The reference current produces a constantly rotating field in which the coil L seeks to set itself so as to link with maximum flux at the moment when the signal

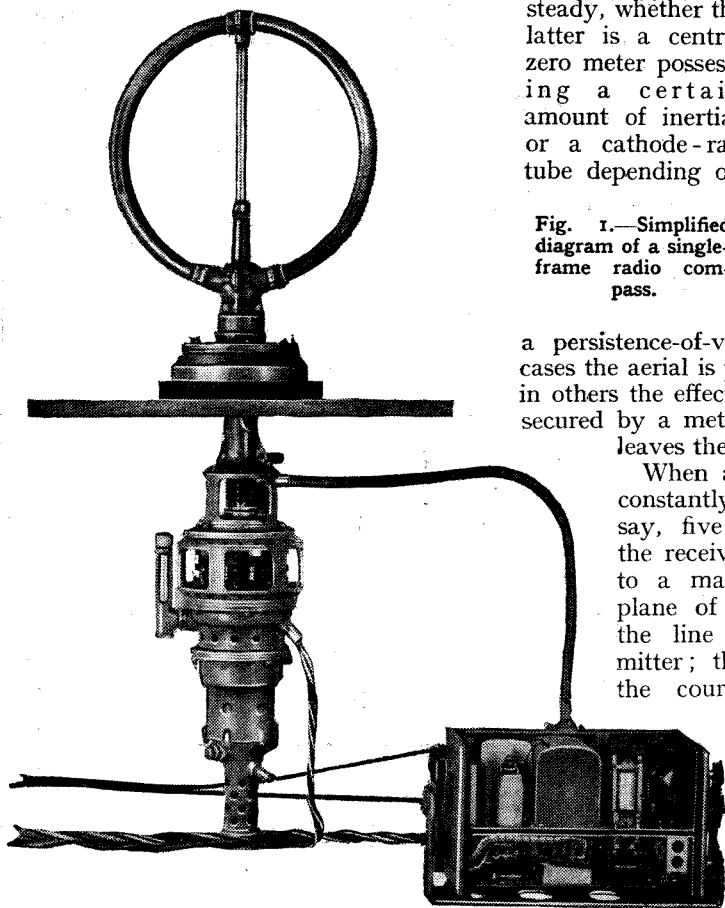

A direct-reading aircraft direction-finder produced by Standard Tele-phones and Cables.

The Radio Compass— current is greatest. If the transmitter is located along the fore-and-aft line of the machine, this will occur when the needle points to zero, but for any other position of the transmitter the coil L must move in one direction or the other to a point where both the flux and the current are in phase. The needle will then show the bearing of the transmitter relatively to the fore-and-aft line of the machine.

Fig. 2 (a) shows another direct-reading instrument in which the rotating frame F is combined with a vertical aerial A to produce the well-known "heart-shaped" curve of Fig. 2 (b). This gives only one point of maximum and one point of minimum signal strength, so that it is free from the

Fig. 2.—Rotating frame radio compass giving indication of sense. Diagram (b) explains its action.

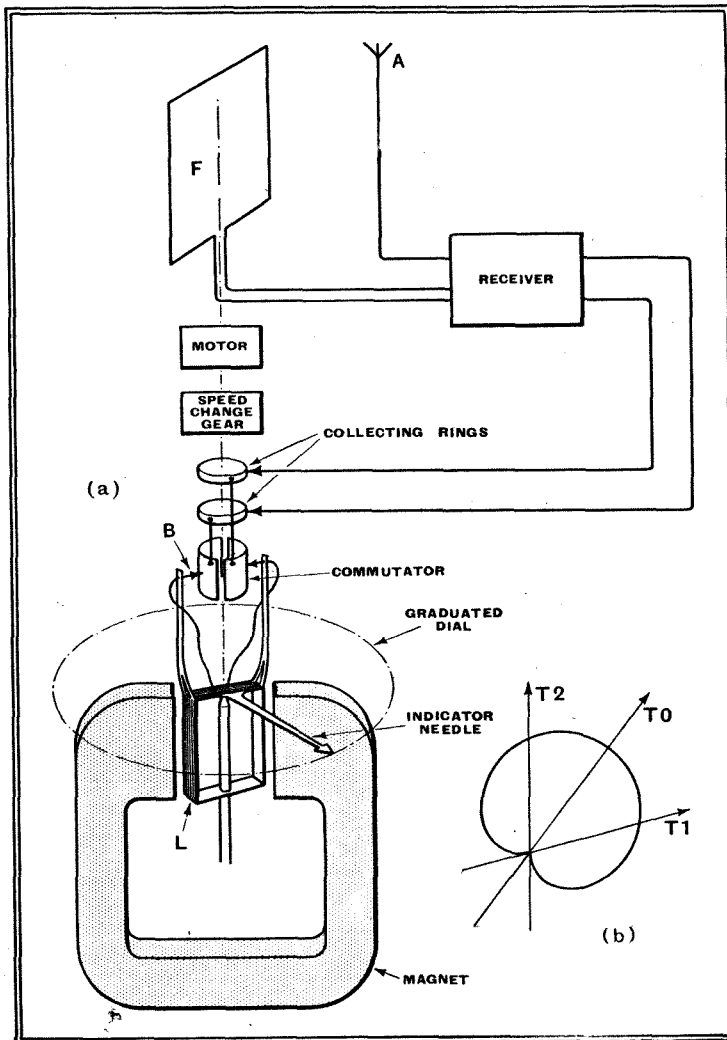

usual 180 deg. ambiguity of the single frame. The indicator is operated by reversing the pick-up current each time the aerial passes through the fore-and-aft line of the machine and balancing the currents collected on one side of the reversing switch against those collected on the other side.

The frame is rotated by a motor, which also drives the reversing switch or commutator (and its collecting rings) at double speed. The signal pick-up from both aerials is first combined in the receiver and the output is fed to the collecting rings of the commutator. The indicator needle is carried by a galvanometer coil L, which swings about a pivot between the poles of a magnet and is fed with current from the commutator through brushes B.

Operation of Indicator

If the beacon transmitter is situated along the fore-and-aft line of the machine, that is, in the direction marked T_0 in Fig. 2 (b), the commutator will collect exactly equal currents on both sides of the reversal point and the indicator needle remains at zero. But if the machine is heading in a different direction, such as T_1 or T_2 , the commutator (which is fixed relatively to the fore-and-aft line) no longer

collects equal currents. For the position T_2 the excess current will tend to rotate the coil L clockwise, whilst in the position T_1 the conditions are reversed. In both

In Fig. 3 the aerial system is kept stationary and the critical bearing line is ascertained by a method of switching—an arrangement which is particularly suitable for use when "homing" or flying directly on to a distant beacon. The frame aerial F is connected to the top grid of a pentode valve, and the output from this valve is combined with the pick-up from the vertical aerial A and fed to the receiver, where it produces a "heart-shaped" response. The two lower grids of the pentode are back-coupled at L so as to generate a local oscillation having a frequency of, say, 100 cycles a second. The output from the receiver is also fed back at L_1 .

Valve-controlled Switching

The local oscillation produces the effects shown in detail in Fig. 4, where curve 1 represents the RF signals picked up by the non-directional aerial A, whilst 2 and 3 show the signals picked up by the frame aerial on two opposite sides of its critical minimum position. The phase of the current in a frame aerial reverses as it passes through this point, so that whilst curve 2 is shown in phase with the non-directional signals, curve 3 is drawn in phase-opposition. Curve 4 is the low-frequency oscillation produced in the circuit L, and curve 5 shows how it is modulated, through the pentode valve, by the frame signals. The signals from the non-directional aerial A do not pass through the pentode, and therefore remain unaltered, but curves 6 and 7 show their effect on the signals received by the frame according as the latter points to one side or other of the critical bearing line. In one case the two signals reinforce each other, whilst in the other they are in opposition.

The meter M is adjusted by a potentiometer P until the needle points to zero, when the normal current from the middle grid (which forms the anode of the local-oscillator part of the valve) passes through the output resistance R. The needle will then be deflected to one side or other of

cases, however, the torque is such as to urge the needle towards the "maximum" position T_0 , that is, towards the line of the distant transmitter, so that the indicator shows the angle which this bearing line makes with the flight of the aeroplane.

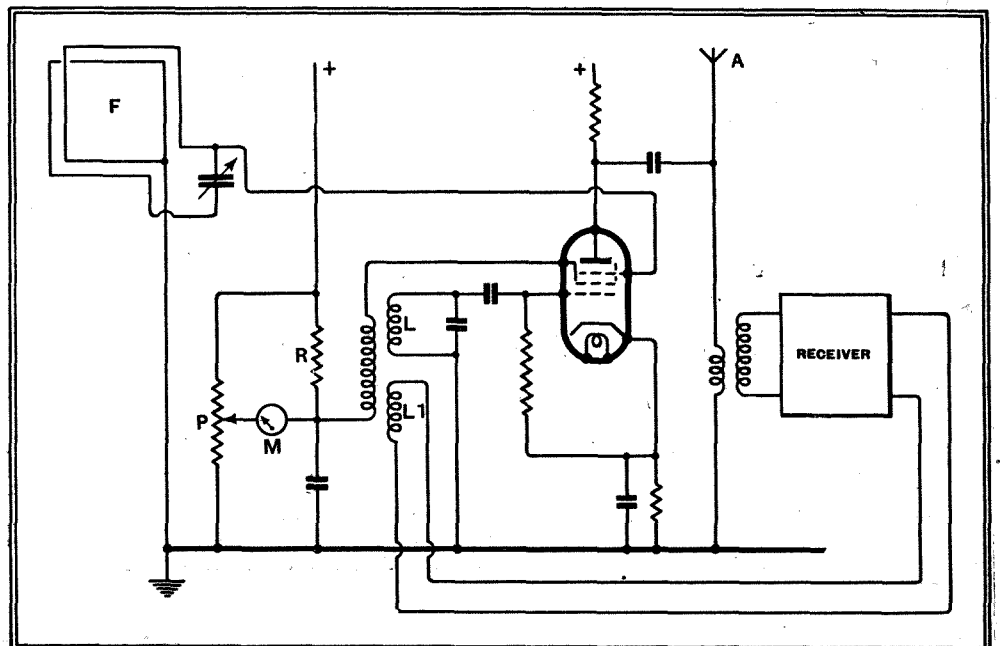

Fig. 3.—Homing compass with high-speed switching and fixed frame.

Radio Compasses—

the zero as the frame aerial is turned to the right or left of the critical bearing line.

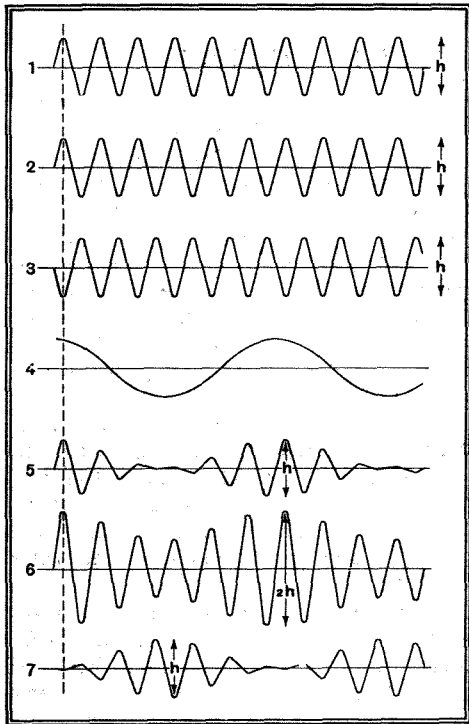

Fig. 4.—Effect of high-speed switch on received signals.

As the frame aerial is usually mounted on the fuselage so that it is fixed relatively to the fore-and-aft line of the aeroplane, the indicator will show automatically any deviation from the straight-line course when the machine is "homing" on to a

beacon station. Preferably, the signals are fed to two different pentode valves which operate in the manner just described to light up separate port and starboard glowlamps if the machine yaws to one side or other of its proper path.

In Fig. 5 two fixed frame aerials A, B, mounted at right-angles to each other, are used to secure a similar result. The strength of signal picked up at any instant by each aerial depends upon its setting relatively to the distant beacon, just as in the well-known Bellini-Tosi arrangement. As shown, both aerials are coupled to an

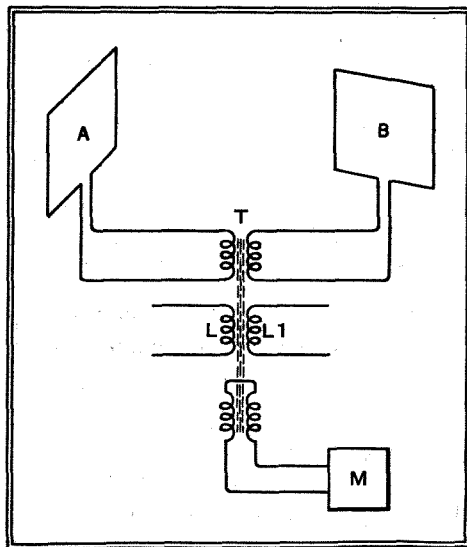

Fig. 5.—Non-rotating crossed frame compass.

iron-cored RF transformer T, to which a locally generated modulating current of,

say, 100 cycles, is supplied through coils L, L1. In this instance the local current must be fed in quadrature to correspond with the right-angled setting of the two aerials.

The local current varies the permeability of the iron core of the common transformer, and so modulates the incoming signal at that frequency before the latter is fed in phase to the meter M. Here the signal current is compared with the locally generated current, which is also supplied directly to the meter in order to serve as a reference. Any difference in phase between the two currents will then force the indicator needle to set itself, in the manner already explained, so as to indicate the bearing of the distant transmitter.

Electro-Acoustics. By Prof. Erwin Meyer. 117 pages, 84 illustrations, including 24 half-tones. G. Bell and Sons, Ltd. Price 10s.

THE title and list of contents (I. Physical and Physiological Foundations. II. Electro-Acoustical Measurements. III. Microphones and Loud Speakers. IV. Sound Recording Technique, and Electrical Music. V. Architectural Acoustics) suggest that this might be yet another standard textbook on a subject which, long neglected, is now reasonably well served by general textbooks for the student.

The contents list is certainly familiar, but the treatment, while it retains enough well-known theory to give continuity, makes frequent excursions into those fascinating byways which the originality of Dr. Meyer and his co-workers at the Institute für Schwingungsforschung, Berlin, and other investigators in Germany, have opened up.

There is a strong bias towards experimental methods and many useful hints for those engaged in acoustic measurements, particularly in connection with architectural acoustics. The principle underlying the measurement of velocity amplitude in gramophone records by optical methods is explained in detail, as are the analysis of sounds of short duration by the Gruzmacher grating and the Freystadt spectrometer.

On the subject of loud speakers there is some very useful information concerning baffles, which suggests that interference patterns may still exist even when the radiation from the back of the cone is absorbed; also a comparison of transient measurements at different parts of the frequency scale.

Electrical musical instruments are discussed with much interesting data on electrical pianos.

This is altogether a stimulating work and one which naturally supplements the recognised text-books on acoustics. F. L. D.

HENRY FARRAD'S SOLUTION

(See page 410)

YES, Tony has slipped up. As he mentions an AC ammeter, presumably the mains are AC, and he is wrong in supposing that watts in an AC circuit are equal to volts×amps. In an inductive load such as a refrigerator motor the actual power is only a fraction of volts×amps, this fraction being known as the power factor. Supposing the power factor to be 0.5, the current would be 1.1 amp, which would produce *four* times as much heat in the suppressor coils as the current Tony bargained for, because heat is proportional to the square of the current.

TELEVISION PROGRAMMES

Sound 41.5 Mc/s

Vision 45 Mc/s

THURSDAY, MAY 4th.

3, Stanley Holloway in "Eastern Cabaret," with Browning and Starr and Hari Sin Bey, compère. 3.45, 239th edition of Picture Page.

9, Edward Cooper and Patricia Leonard in "Order to View," No. 3. 9.45, Gaumont-British News. 9.55, 240th edition of Picture Page. 10.25, News.

FRIDAY, MAY 5th.

3-4.30, "On the Spot," the play by Edgar Wallace. Cast includes Arthur Gomez, Percy Parsons and Joan Miller.

9, "London Wall," a play by John van Druten. Cast includes Lewis Stringer, Barbara Couper and Nadine March. 10.30, News.

SATURDAY, MAY 6th.

12-12.45, The Departure from London of The King and Queen on their State Visit to Canada, the United States, and Newfoundland. Television cameras will be situated outside Buckingham Palace and at Waterloo Station.

3, A Gershwin programme by Eric Wild and his Band. 3.25, Cartoon Film. 3.30, Punch and Judy show by Frank Worth. 3.40, British Movietone news. 3.50, "In Our Garden,"—C. H. Middleton.

9, "Eastern Cabaret" (as on Thursday at 3 p.m.) 9.55, Gaumont-British News. 10.5, Wyndham Goldie in "Five at the George," a ghost play by Stuart Ready. 10.30, News.

SUNDAY, MAY 7th.

3, Pas Seul. 3.15, Cartoon Film. 3.20, "Early

Days," Film. 3.30, "Anna Janska, The Bolshevik Empress," by George Bernard Shaw. 8.50, News. 9.5, Friends from the Zoo. 9.20, Cartoon Film. 9.25-10.50, The Hungarian State Ballet from the Adelphi Theatre in "Hungarian Rhapsody."

MONDAY, MAY 8th.

3-4.30, "London Wall," (as on Friday at 9 p.m.)

9, Starlight—Peggy Wood. 9.10, Salute to America," a picture of life across the Atlantic. 9.45, Gaumont-British News. 9.55, Black and White Boxing Demonstration. 10.15, Bridge Demonstration by a team of International Women Players. 10.30, News.

TUESDAY, MAY 9th.

3, Renée Houston and Donald Stewart in Cabaret, with Charles Harrison and Afrique. 3.40, Gaumont-British News. 3.50, "Looking for a House." Pearl Binder describes her trials with the help of drawings.

9, O.B. from the stage of the Coliseum. 10, The Right Hon. R. B. Bennett, K.C.—Speaking Personally. 10.10, "A Game of Cut-Throat," a "telecrime." 10.35, News.

WEDNESDAY, MAY 10th.

3, "Order to View" (as on Thursday at 9 p.m.) 3.45, Cartoon Film. 3.50, British Movietone news.

9, Talk by Frank Lloyd Wright, the American architect. 9.10, Starlight—Ivor Moreton and Dave Kaye. 9.20, Cartoon Film. 9.25, Week ends in the Country. 9.45, Gaumont-British News. 9.55, "Castle in Spain," a programme of dances to music by Albeniz and Granados, with Sidonie Goossens, harp. 10.30, News.

Modern Insulating Materials

Part II.—CERAMICS: THEIR PROPERTIES AS INSULATORS AND DIELECTRICS

By L. HARTSHORN, D.Sc.

IT is well known that ceramics in the raw state take the form of a clay, which can be moulded to shape while wet, dried without change of shape (although usually with some shrinkage), and finally hardened or vitrified by heating to a very high temperature.

China clay or kaolin is a hydrated compound of alumina and silica. The clay used for the manufacture of ordinary porcelain is a fine-grained mixture of this material with quartz and felspar (which is a complex compound of potash, alumina and silica). The felspar acts as a flux by combining at the high temperature with a certain proportion of the other materials to form a glass, which softens at a much lower temperature than the other constituents and, therefore, serves to bind them together into a coherent mass. Thus the final product may be regarded as a mass of microscopically small crystals bonded together by thin films of glass.

It is interesting to note that these materials are the inorganic equivalent of the organic plastics: the one material consisting of an agglomeration of tiny mineral crystals bonded by thin glassy films, and the other particles of wood or cellulose fibre bonded by an organic resin. The analogy even extends to the method of fabrication, for ceramic components may be made by dry dust pressing as well as by the wet plastic process. Both materials owe their industrial importance in greater part to the fact that such moulding processes lend themselves so well to mass production. Large ceramic components can also be made by a process of casting.

The importance of the new ceramics to the radio industry is due to the wide range of their electrical properties. It is obvious that the electrical properties of ceramics will vary very considerably with the nature and relative proportions of their crystalline and glassy components. The recent successes of the ceramic technologist in producing materials which are so admirably suited to certain radio applications are due to the fact that he has succeeded in bonding certain mineral crystals having the desired electrical properties with the minimum quantity of glassy material.

Glasses, except those like fused quartz which are of very high melting point, are electrically inferior to these mineral crystals, and therefore the proportion of readily fusible glassy component must be kept small. It is, however, equally important that the material shall be impervious to water. The whole mass must be thoroughly bonded or "vitrified," and not porous. These conditions are evidently to some extent conflicting, and it is therefore

ONE of the most remarkable developments in insulating materials in recent years has been the increasing use of ceramics in the radio industry. Not only are these materials very stable mechanically, but they can be blended to give a wide range of dielectric properties

perhaps not surprising that nominally the same ceramic materials vary considerably in quality. Nevertheless, all the new materials mark a great advance on ordinary "electrical porcelain."

The new materials may be divided into groups according to their principal crystalline constituent. The first group is the

the main considerations, e.g., for coil formers. They are made from steatite (soapstone) or talc, both hydrated forms of magnesium silicate, with a small proportion of, say, kaolin and felspar (a potassium aluminosilicate) to form the glassy binder. Glasses containing the alkali metals are of relatively high power factor, since they contain sodium or potassium ions which give rise to electrolytic conductivity. Thus by the use of fluxes other than felspar the losses may be made even smaller. Examples of these materials are "Frequentite," "Calit," and "Calan." They have a dielectric constant of about 6, and power factors ranging from about 0.001 to 0.002 at frequencies of the order of 10 Mc/s.

It should be mentioned that ordinary electrical porcelain is also made from steatite, but the proportions of clay and felspar used in its manufacture are greater than those in the high-frequency ceramics. Manufacture is correspondingly easier, but the power losses are of a higher order. Steatite materials have also been used for many years for special experimental work in which insulation capable of withstanding very high temperatures is required. For such purposes the material is moulded approximately to the shape required and given a preliminary firing, after which it is strong enough for the final shaping by turning, drilling, tapping, etc. The component is then fired at a higher temperature to complete the vitrification.

For certain applications, such as coil formers used in the construction of constant-frequency oscillators, the smallness of the thermal coefficient of expansion is the main criterion, and for such work materials in which the main crystalline constituent is cordierite 2MgO , $2\text{Al}_2\text{O}_3$, 5SiO_2 have been found advantageous. These may be regarded as developments of the steatite materials, in which some of the steatite is replaced by alumina.

A completely different class of ceramics is that in which the principal constituent is rutile, a crystalline form of titanium dioxide, which is remarkable for its very high dielectric constant. It has been known for thirty years or more that the dielectric constant of rutile has the very

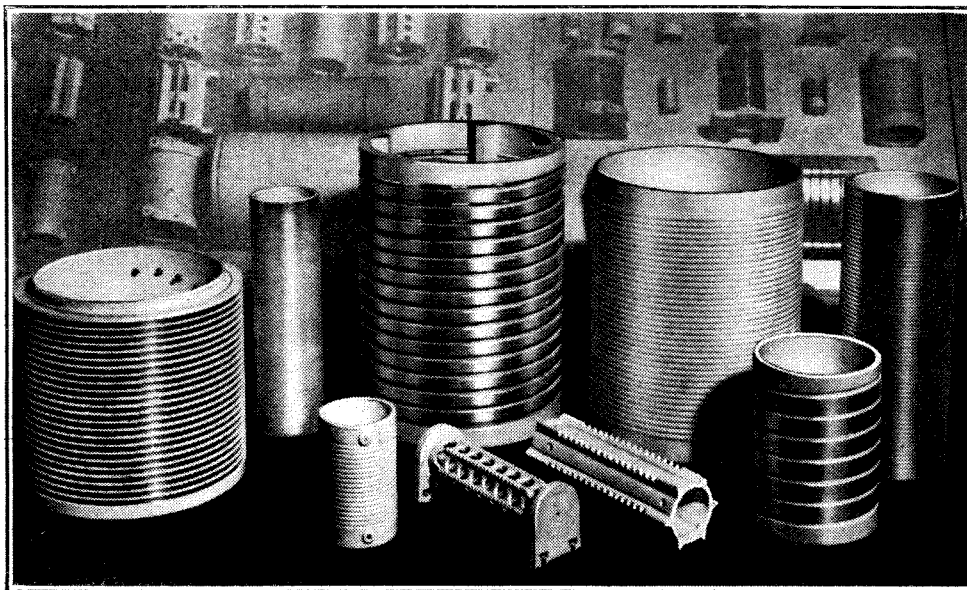

Fig. 4.—Coil formers made from "Calit," a ceramic material of the steatite group.

steatite group, in which the principal constituent is magnesium silicate. These materials are specially valuable where low dielectric loss (and, of course, great mechanical strength and permanence) are

constituent is rutile, a crystalline form of titanium dioxide, which is remarkable for its very high dielectric constant. It has been known for thirty years or more that the dielectric constant of rutile has the very

Modern Insulating Materials—

large value of 170 for fields in the direction of the axis of the crystal and about 90 in a perpendicular direction, but only quite recently has it been discovered that ceramics consisting mainly of rutile can be commercially produced, and that not only have they the high dielectric constant of rutile, but also a fairly low power factor at radio frequencies. They are, therefore, specially valuable for the construction of small fixed condensers. Unlike mica, such materials require no mechanical protec-

form a titanate. An example is "Tempa S." in which the principal crystalline constituent is magnesium titanate. This material has a dielectric constant of about 16, and when perfectly dry a power factor which may be as low as 0.0005 at audio-frequencies and 0.0001 at radio-frequencies. In addition its temperature coefficient of capacity is almost negligible.

When it is remembered that these remarkable electrical properties are combined with a very high degree of permanence of linear dimensions and excellent

Not that these two groups of materials are to be regarded as merely competitors. The flexibility of the resins is as valuable in its own way as the rigidity of the ceramics, and all radio experimenters will find many uses for both classes of material.

CLUB NEWS**Aldershot and District Radio Society**

Headquarters: 41, Grosvenor Road, Aldershot, Hants.
Hon. Sec.: Mr. H. Atthill, "Ardivarney," College Road, Farnham, Surrey.

The first general meeting of the society, held on April 6th, opened with a junk sale. Morse practice is held at each meeting, and, in addition, certain transmitting members are giving slow morse "over the air" at stated times. The club hopes to arrange a visit to the local telephone exchange and a visit to view the apparatus at the local cinema. A field day is also to be held.

The next meeting will be held in the first week of May.

Bethnal Green Radio Club

Headquarters: The Institute, 224, Bethnal Green Road, Bethnal Green, London, E.2.
Meetings: Tuesdays and Thursdays at 8 p.m.

Hon. Sec.: Mr. L. Bard, The Institute, 224, Bethnal Green Road, Bethnal Green, London, E.2.

The club devotes its Tuesday meetings to the theoretical side of radio engineering. Lectures are usually accompanied by a demonstration of apparatus. Thursday evenings are given over to practical constructional work. A Morse class is also held on Thursday evenings.

This club is additional to those given in the directory of wireless societies, published in *The Wireless World* of April 6th.

International Short-wave Club

Headquarters: R.A.C.S. Hall, Cavendish Grove, Wandsworth Road, London, S.W.8.

Hon. Sec.: Mr. A. E. Bear, 100, Adams Gardens Estate, London, S.E.16.

On April 21st Mr. M. Raymond gave a lecture and demonstration arranged by Baird Television, Ltd., a Baird Type T18 model being used for the purpose.

The society has erected a 50ft. mast on the roof of its headquarters. The mast is a wooden structure,

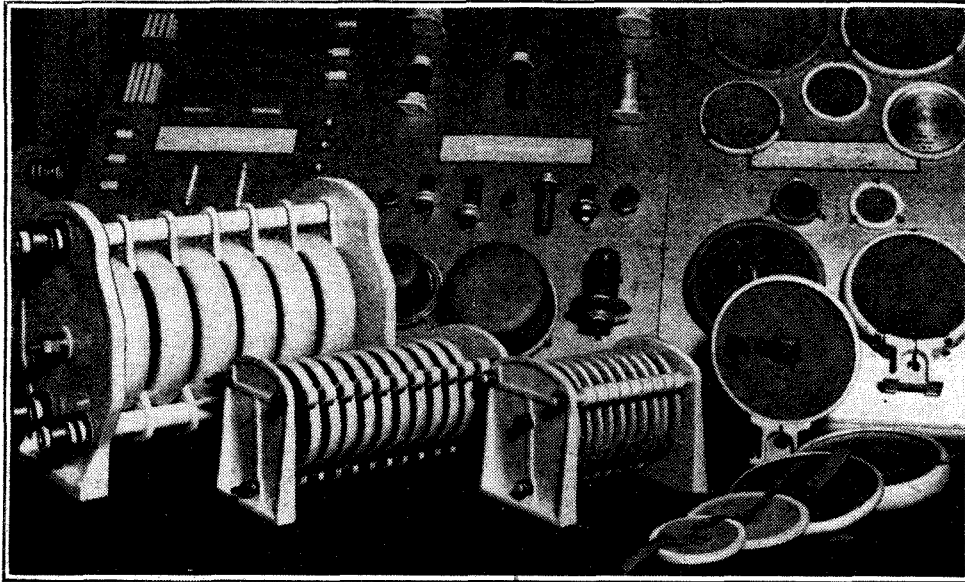

Photo: Courtesy United Insulator Co., Ltd.

Fig. 5.—Condensers made of ceramic material of the rutile group.

tion. It is only necessary to take a small disc of the material and deposit metal films on two opposite faces, and the condenser is complete.

The earlier materials of this kind had dielectric constants varying from 20 to 100 according to the proportion of rutile, but more recently the very high dielectric constants have been dispensed with in order to secure certain other properties. Constancy of capacity with rise of temperature is obviously of considerable importance, for variations in working temperature are often considerable, and it is important that these shall not cause appreciable changes of capacitance. The temperature coefficient of capacitance of a good small air condenser may be no more than 0.003 per cent. per 1 deg. C., but for materials consisting mainly of rutile the coefficient is negative and amounts to about 0.07 per cent.

Power Factor at RF and AF

For the steatite materials the coefficient is positive, so that by using mixtures of the two kinds, ceramics with a dielectric constant of about 10 and a negligibly small coefficient may be produced. Another disadvantage of the earlier ceramics of the rutile group was that the power factor, although very low at very high frequencies, tended to become high at lower frequencies. This disadvantage has been overcome in rutile ceramics by combining the titanium dioxide with an alkaline earth to

thermal properties, it will be clear that the various short-wave components now manufactured from these materials constitute a great advance on previous practice. There is, however, still one fly in the ointment, and that is that all the ceramics have an affinity for water. They may be no more porous than glass when properly vitrified, but they appear to have the power of absorbing an appreciable amount of water from the atmosphere. This does not greatly affect their properties at very short wavelengths, but is apt to be serious at the lower frequencies. In practice steps are taken to ensure that as far as possible the materials are used in the dry condition. Thus small condensers are almost invariably protected by a coating of some kind of varnish after drying.

Probably a great part of the moisture is held by the material in the form of a surface film, and it is therefore very important that the surface should be kept clean and not handled, for dirty water has a much greater conductivity than clean water. A few dirty finger-marks on the surface of the ceramic insulator of a standard laboratory condenser will often cause a serious deterioration of its properties, especially at the lower frequencies. The same is true of fused silica. If the ceramic industry is able to overcome this disadvantage it will probably be able to supply us with the ideal insulating material.

Meanwhile the polystyrene resins hold a decided advantage on this particular point.

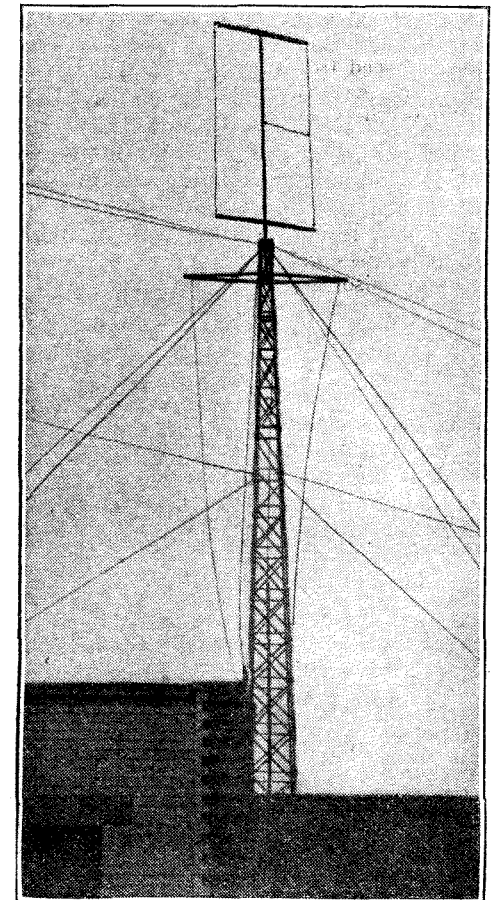

The new aerial system installed at the headquarters of the International Short-wave Club (London Chapter).

and provision is made for a television dipole and also for short-wave reception and transmission. Experiments in transmitting are at present being carried out on a dummy aerial circuit (call sign 2CLR) prior to going on the air.

NEWS OF THE WEEK

ECONOMISING IN METAL

New Methods of Set Construction

THE full effect of the German Four-Year Plan and the order to economise in the use of metals which have to be imported from foreign countries will be felt for the first time when next season's receivers are put on the German market.

One hundred and thirty metric tons of iron will be saved on every hundred thousand sets manufactured by the introduction of a new type of vertical presspahn chassis and some twenty-eight metric tons by the replacement of the iron loud-speaker cradle by one of wood.

Until now, twenty - five grammes of precious metal were required for superhet wave-change switch contacts, but in future only six grammes will be used. Instead of fitting small alloy rivets to the bronze contact spring of wavechange switches an ultra-thin coating is pressed on to it, and flat and pointed contacts are produced by simply pressing out part of the strip. Further to save metal the thickness of the covering has been reduced from 0.04 mm. to 0.01 mm. without, it is stated officially, ill-effects on the life of the switch!

As tin has to be imported, the amount used is to be reduced to a minimum by employing the welding process instead of soldering in all cases where this is possible, and also, by decreasing the percentage of tin in the solder to forty. The introduction of a new method of making coil cans by the cold-spray method will result in a saving of 74 per cent. in imported metals.

Further saving is effected by the use of artificial silk covered Litz and by substituting home-grown flax thread in the place of the cotton used for tying the ends of the coils.

It is stated in the official report that the changes will in no way lower the quality of receivers.

EMPIRE DAY PROGRAMME

MESSAGES of loyalty and devotion to the Crown from all parts of the United Kingdom will be heard on Empire Day, May 24th, in the programme arranged by the Canadian Broadcasting Corporation, beginning at 7.15 p.m., B.S.T., and concluding with the voice of the King speaking from Winnipeg at 8 p.m.

The honour of supplying a contribution in the name of England rests with a boy from the training ship H.M.S. Conway.

RADIOLYMPIA, 1939

Some Features : Televiewers' Corridor, Technical Section, Model Factory and Television Equipped Amphitheatre

THE chairman of the Radio Manufacturers' Association Exhibition Committee, Lt.-Col. G. D. Ozanne, outlined in a message to overseas buyers the main features of this year's Radio Exhibition, which is to be held at Olympia from August 23rd to September 2nd. It would appear that the Show is to surpass all others, for, he says: "It will reflect the predominant position which radio, after seventeen years of existence, has won for itself in the life of the nation and the individual."

Every effort is being made to bring before the public the advantages of 1940 receivers, and to impress upon listeners throughout Great Britain, what they are

to know that a technical section is being incorporated this year.

Last year's decision to drop the Radiolympia Theatre has been reversed, and what is to be known as the Amphitheatre equipped with television cameras will be built. It will be possible to relay shows given on the stage to television receivers on the stands as well as to a "televiewers' corridor."

A complete model factory, with moving conveyor showing the assembly and testing of receivers, is proposed for erection in the annexe. With the object of showing the part played by wireless in the Services, special features are being arranged by the Royal Navy, the Army and

LEARNING MORSE

Two Methods of Study

MANY readers have written asking how they can learn morse in the minimum of time in order to fit themselves for the various defence services for which this knowledge is required. There is, of course, no royal road to acquiring this knowledge, and it is solely a matter of steady and consistent practice, but much time can be saved by adopting the correct methods.

Much help in this direction can be obtained by a study of the recently published handbook "Learning Morse," and by constructing the morse practice set described therein. It cannot be too strongly emphasised that skilled operating is largely a question of knowing, and in-

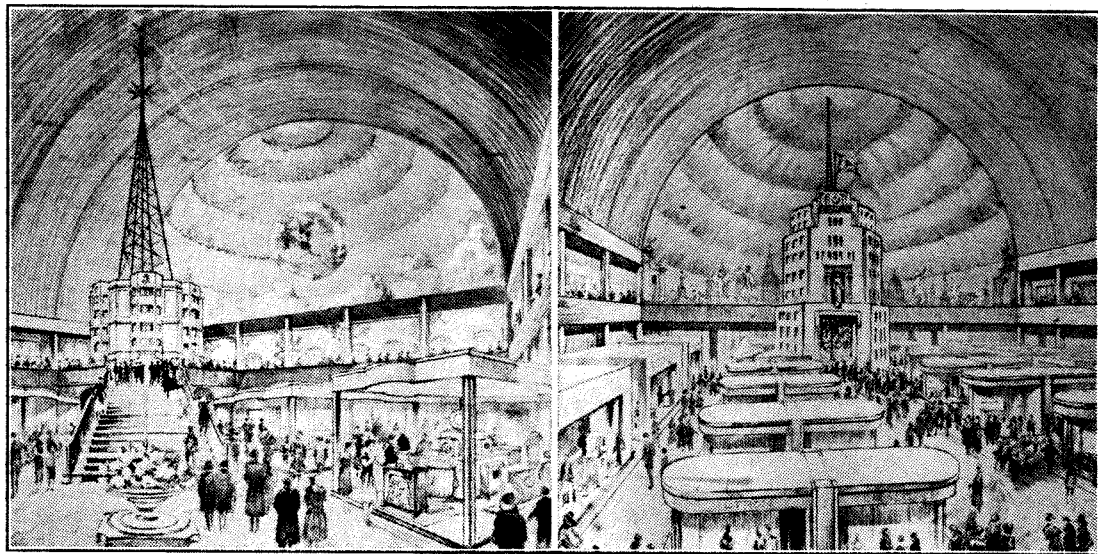

SYMBOLIC FEATURES of the Exhibition, at the east and west ends of the main hall, will be reproductions of part of Alexandra Palace, complete with replica of the television aerial, and Broadcasting House.

missing by using old and obsolete receivers. Readers of *The Wireless World* will be pleased

the R.A.F. A cinema, showing films of wireless interest, will be erected in the smaller hall.

C.B.S. TELEVISION

B.B.C. Adviser Sails for New York To-day

MR. GILBERT SELDES, Television Director of the Columbia Broadcasting System, and Mr. D. H. Munro, B.B.C. Television Productions Manager, sail for New York on the s.s. *Georgic* to-day.

Mr. Seldes has been in London since April 26th making a brief study of television production technique at Alexandra Palace, and Mr. Munro, as previously stated, is being lent to the C.B.S. for the purpose of assisting in the setting up of a New York "Alexandra Palace."

Speaking in New York recently on British television and

the arrangement whereby advice should be sought from the B.B.C., Mr. Seldes said:

"Munro is ranked among the world's foremost authorities in the field of television. Our joint observations and discussions will help us to find the methods which will prove useful and applicable to our American production and audience. England is far advanced in the matter of television production technique, but each country must develop its own methods, material and style of production. It is only background technique which remains universal."

stantly recognising, the rhythm associated with each letter. In the handbook, aids to memorising the code are so devised that the learner is automatically guided along the right path. "Learning Morse" is issued by the publishers of *The Wireless World*, and costs 6d. (by post 7d.).

The best method of acquiring proficiency is, naturally, to enlist the services of somebody who is already a proficient telegraphist, but this can seldom be done. It is not always convenient for two learners to get together for mutual assistance, although this should be done if possible. The lone learner can, however, do much by himself with the aid of a morse practice set.

Another useful aid to learning the code is the gramophone. A set of three instructional record-

News of the Week—

ings have been prepared by Mr. C. E. Masters, who is an Instructor of Signals to the R.A.F. Volunteer Reserve. These records contain messages at a speed as low as two words per minute and ranging up to 30 words per minute. The records cost 2s. 6d. each, or 7s. for the set of three, and can be obtained from Mr. Masters at Orchard House, Finchampstead Road, Wokingham, Berks.

B.B.C. REVENUE**Statement in the House of Commons**

THE Assistant Postmaster-General, Sir Walter Womersley, replied non-committally in the House of Commons last week to a suggestion that the B.B.C. should receive the whole of the revenue from wireless licences.

He said that from the total of £36,000,000 derived from receiving licences since the inception of the broadcasting service, the Post Office had retained about £4,000,000 to cover its expenses, the B.B.C. had been paid about £22,300,000, and the Exchequer had retained about £9,700,000.

Under present arrangements the amount accruing to the Corporation to cover all broadcast services represented about 81 per cent. of the total licence receipts, while the Post Office retained 9 per cent. for its expenses and the Exchequer received approximately 10 per cent.

NORWEGIAN STATIONS**Geographical Considerations**

WITH the recent addition of two new 100-kW Regional transmitters, the Norwegian state broadcasting organisation, Norsk Rikskringkasting, now controls a network of seventeen stations with an aggregate aerial power of 360 kW. Fourteen of these stations have been erected since 1933, when the broadcasting organisation was taken over by the State.

The comparatively large number of broadcasting stations in Norway is necessitated by the shape and nature of the country, which has also necessitated the extensive use of wire links, and the technical staff of the Norsk Rikskringkasting has become expert in long-distance line transmission. The longest HF cable is 2,160 km (1,350 miles), which relays the programme from Oslo to Vadso in North Norway.

The new 5-kW short-wave transmitter at Jeloy has, since May 1st and until further notice, ceased normal broadcasting, as it will be required for telegraphic purposes during the summer. Its place is being taken by the former 1-kW station at Jeloy.

GERMAN AMATEURS**Licensing Regulations**

THE position of German amateur transmitters has now been defined by the introduction of a new law. Any full German citizen may now apply for a transmitting licence provided he is over eighteen, a member of the official amateur organisation and that the police give their permission. He will, of course, have to pass a technical examination.

So far as listening is concerned the amateur is limited to broadcasting and amateur transmissions. Should an operator hear other services, he must keep the very existence of these services secret.

Transmission is restricted to telegraphy, and the maximum aerial power is 50 watts, except

in special cases, where 100 watts is permitted. Amateurs are allowed to transmit within the following bands: 3.5-3.6, 7.7-3.14-14.4 and 28-30 Mc/s.

The cost of a transmitting licence is the same as that of the receiving licence, Rm.2 per month, which licence also permits the use of any receivers belonging to the transmitter.

The operation or even the mere possession of a secret unlicensed transmitter renders the culprit liable to fifteen years' penal servitude. If the station is operated seditiously against the Party it is a crime of high treason, which is punishable by the death penalty or a long term of imprisonment according to the degree of malice.

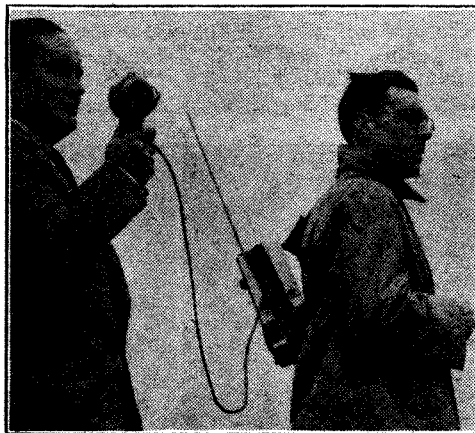

THIS KNAPSACK TRANSMITTER was used for the first time in a B.B.C. transmission during the English Amateur Golf Championship at Birkdale last Saturday. The equipment enables a commentator to move freely about at a sports meeting or in the street, while the low-power radiations from the portable transmitter are picked up by an O.B. van parked in the vicinity.

TELEVISION SOUND**Audio-Frequency Equipment at Alexandra Palace**

SOME interesting information about the sound accompaniment to television was disclosed in a paper by Messrs. Turnbull and Clark (Electric and Musical Industries, Ltd.), which was discussed last night at the Institution of Electrical Engineers.

It goes without saying that full advantage has been taken of the high carrier frequency to extend the range of audio-frequency response (the overall characteristic of the system is flat within ± 2 db from 40 to 10,000 cycles) but in the authors' opinion it is the extremely low harmonic distortion, particularly at the low-frequency end of the scale, which is the foundation of the superior sound quality from Alexandra Palace. Over the complete programme channel under normal working conditions the third harmonic at 40 c/s is only 0.66 per cent. and at 1,000 cycles, less than 0.15 per cent. This has been accomplished by the extensive use of triodes with high anode loads and negative feed-back in the amplifiers.

The microphones used are of the pressure and velocity types.

The former is the well-known E.M.I. moving-coil microphone with balsa wood diaphragm. The velocity microphone is a comparatively new design with a stretched, uncorrugated ribbon about 1 inch long and 0.0005 inch thick.

The intensity of the radio-frequency field surrounding the audio apparatus at A.P. has brought its own problems which have been solved by individual screening of all early stages in amplifiers and the inclusion of separate tuned RF filters in the heater, cathode, grid and anode leads of each valve.

EUROPEAN LISTENERS**Saturation Point Approaches**

STATISTICS issued by the International Broadcasting Union show that although the number of European registered licensees, now totalling 35,130,000, shows a substantial expansion, it is noticeable that the percentage rate of increase over the whole continent is slackening with the approach of saturation point.

On the accepted basis of three and a half listeners to each set,

the potential audience reaches nearly 123,000,000.

The following summary published in *The Birmingham Post* indicates the percentage rate of approximate increase in those countries where pronounced advances have been made in listening during the past year:

Poland	18 per cent.
Greece	30 per cent.
Lithuania	31 per cent.
Estonia	35 per cent.
Bulgaria	37 per cent.

Due to the inauguration of a new high-powered station at Ankara, the number of wireless licence holders in Turkey has been more than doubled during the year. Germany's estimated total, including Czecho-Slovakia, is 12,300,000. Italy by the annexation of Albania is not expected to derive more than 2,000 additional listeners—bringing her total to over a million.

The total number of wireless licences in force in Great Britain and France is now 8,968,600 and 4,957,886 respectively.

NEW YORK WORLD'S FAIR**Sound System in the British Pavilion**

AMONG the features of the British Pavilion at the World's Fair, which opened in New York last Sunday, will be the showing of films portraying conditions and life in England. The Department of Overseas Trade, who were responsible for the British Pavilion, have installed sound and picture projection apparatus manufactured by British Thomson-Houston.

The B.T.H. sound system uses soundheads which incorporate a drive, hitherto used only on recording cameras, in which the film is passed round a drum driven by electromagnetic means to ensure as smooth propulsion as possible, the minimum of film wear and constancy of film path at the point where the track is scanned by the optical system. Another feature is that the sound amplifier includes automatic volume expansion.

MAKING COMPLETE BROADCASTERS

EVERY senior member of the B.B.C. staff is being given an opportunity to become a technician. The summer course of the Staff Training Department includes certain lectures which can be attended by Corporation officials whether or not they are undergoing the course.

The technical lectures coming within this category give a complete survey of the essentials of radio transmission, ranging from elementary electricity and magnetism to the functions of a modern transmitter. Microphones, studio acoustics, mixing and control units, recording, television and short- and medium-wave transmission are all made the subjects of lectures.

214 METRES

Wavelength for a Hypothetical Station

HAVING secured a share in the wavelength of 214 metres for the hypothetical relay transmitter at Norwich, the B.B.C. is not likely to leave the wavelength vacant. The new Montreux Plan comes into operation on March 4th, 1940, and after that date the 214-metre wavelength will be a plum ripe for picking by any predatory transmitter in search of a niche in the ether, for the remaining stations sharing this wavelength are all very low powered.

If the Norwich relay cannot be completed by then, there is a distinct possibility that the wavelength will be temporarily adopted by another British transmitter. Nearby European stations will find the "number engaged."

HOW A VALVE WORKS

A Novelty at the World's Fair

TO show visitors to the New York World's Fair what goes on inside a triode valve and the effect of a magnetic field on a stream of electrons flowing through a vacuum, the engineers of the Westinghouse Electric and Manufacturing Company have built a triode 27 inches high and 7 inches in diameter. It is similar to a standard radio valve except that it has a filament and a grid on each side of the anode so that the action of the electrons is visible from both sides.

The surface of the anode is coated with a fluorescent material so that wherever electrons impinge on the anode a green colour shows. By changing the negative biasing of the grid the stream of electrons to the anode can be varied from zero to the maximum of which the valve is capable.

By placing a permanent magnet near the valve the electron stream can be deflected, thereby showing the effect of the magnetic field on the stream.

The circuit used is similar to that in an ordinary AF amplifier, AC at sixty cycles being applied to the grid. The valve output is connected to a loud speaker and the volume corresponds to the area of the green glow on the anode of the valve.

FROM ALL QUARTERS

New Empire Telegraph Service

A FURTHER stage in the progressive policy of Cable and Wireless for cheapening Imperial communications was introduced last Monday, when a new service of Empire social telegrams was inaugurated. It is now possible to exchange such telegrams within most parts of the British Empire at a flat rate of 5s. for twelve words, plus 5d. for each additional word. To mark the inauguration of the service, telegrams were despatched free on the opening day, May 1st.

News from China

WE are still open to receive, for forwarding to China, reception reports of the Chinese Central Broadcasting Administration's station at Chungking, Szechwan. This 35-kW Marconi station, which transmits under the call-sign XGOY on 25.21 metres (11.9 Mc/s) from 10.30 a.m.-4.30 p.m. and from 9.30-11.20 p.m. G.M.T., is also radiating a transmission from an aerial directed on North America on 16.85 metres (17.8 Mc/s) from 2 to 3.30 a.m. under the call-sign XGOX. News is now broadcast in English four times during the day at 2.50 and 11.20 a.m. and 2 and 10.50 p.m. G.M.T.

Licence Free

THE Danish State Broadcasting Organisation has issued an order which exempts foreign visitors from holding a Danish radio licence to cover the use of portable wireless sets or permanently installed receivers in motor cars or yachts.

Increase of Power

WHILE the Finnish medium-wave transmitter at Viborg is having its aerial power increased from 10 to 20 kW, a stand-by transmitter of 1 kW is operating in its place.

Producing an Electric Charge

SIR AMBROSE FLEMING, D.Sc., F.R.S., the ninety-year-old father of the thermionic valve, read his thirty-seventh paper to the members of the Physical Society last Friday. It dealt with a new method of creating electrification by silica powder falling on a perforated metal sheet, whereby the metal becomes electrified positively and the insulating powder negatively.

Swiss SW Link

WITH the inauguration of a new short-wave station Switzerland now has direct communication with the U.S.A. Hitherto she has been dependent upon relaying facilities via England.

South African Ground Stations

A FURTHER five aerodromes, bringing the total to twenty, are to be equipped by the South African Post Office with "Standard" transmitting, stand-by and DF stations. The transmitters are combined short- and medium-wave sets having outputs of 250 watts for telegraphy and 80 watts for carrier telephony. The change-over between four pre-set wavelengths is easily effected. The DF equipment in each case is a Standard Adcock Type R.4 direction finder with goniometer and receiver installed some 600 feet from the aerials.

Import Restrictions

IN accordance with an order issued by the Norwegian Department of Commerce, no complete wireless receiver or components of foreign makes may be imported without a special licence. This order does not apply to single loud speakers.

Change of Wavelength

BODO, the Norwegian long-wave transmitter, has changed its wavelength to 1,186 metres and Kristianssand has changed to 476.9 metres.

DF Lightship

THE lightship *Abertay*, recently launched for the Dundee Harbour Trustees, will be equipped with Marconi wireless telephone equipment for ship-to-shore communication, and a Marconi radio beacon transmitter.

Navigational Science

A PRIZE of £25 is offered by the Council of the Royal Society of Arts to any person who may bring to their notice an invention, publication, diagram, etc., which, in the opinion of the judges, is considered to be an advancement in the science or practice of navigation, proposed or invented by himself between January 1st, 1934, and December 31st, 1939. This prize is offered under the Thomas Gray Memorial Trust, which was established as a memorial to Thomas Gray, C.B., who was for many years assistant secretary to the Board of Trade (Marine Department). The objects of the trust are "The advancement of the science of navigation and the scientific and educational interests of the British Mercantile Marine."

The Australian Trend

THERE are 1,100,000 wireless sets in use in Australia and nearly 650,000 telephones for a population of fewer than 7,000,000.

Radio Relays

ACCORDING to a report issued by the Finnish Post Office relay systems appear to be unpopular in that country. The total number of subscribers to the system amounts to only 970.



HER MASTER'S VOICE (with apologies to H.M.V.). Zoe, an Alsatian belonging to the Alexandria (Sydney) police force, has been trained to act upon the wireless commands of her master which are conveyed to her by a small receiving set strapped to her back.

Legal Actions Broadcast: A New Method

THE B.B.C. is watching with interest an experiment now being carried out at Poste Parisien. Important trials are being broadcast, not direct from the police courts, but by reconstructions in the studio. Skilled reporters provide verbatim accounts of the trials and the "parts" of prosecutor, defendant and witnesses are taken by actors at the microphone.

Conversazione to I.E.E. Overseas Members

A CONVERSAZIONE and reunion of members of the I.E.E. from overseas is being arranged to take place in the Institution building, Savoy Place, London, W.C.2, on Tuesday evening, June 13th. Members from overseas who will then be in England and would like to be present are asked to communicate with the secretary immediately on their arrival in England.

By Any Other Name . . .

"MIKE" has long been the recognised abbreviation for microphone. In America the television camera is known as an "Ike" (Iconoscope).

Shocks for "Mikes" and "Ikes" ?

MR. S. C. H. DAVIS, of our sister-journal, *The Autocar*, is lending his ancient Léon Bollée car, of 1898 vintage, for the television O.B. from the Crystal Palace race-track on May 19th. Precautions will be taken to shield the microphones while the veteran vehicles are being started up. Emitron cameras have also to be protected against sudden shocks.

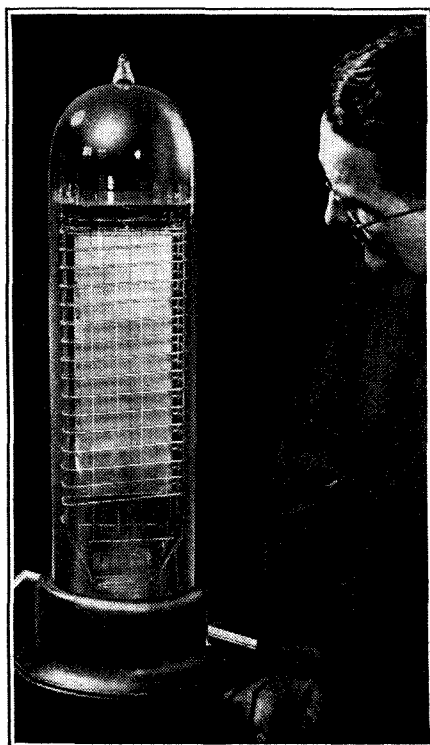

OUTSIZE IN RECEIVING VALVES, built to show visitors to the World's Fair how the electrons move.

Test Report

MURPHY A56V

Television Receiver (15 Valves + 3 Rectifiers) for Alexandra Palace Sound and Vision Only Price £30

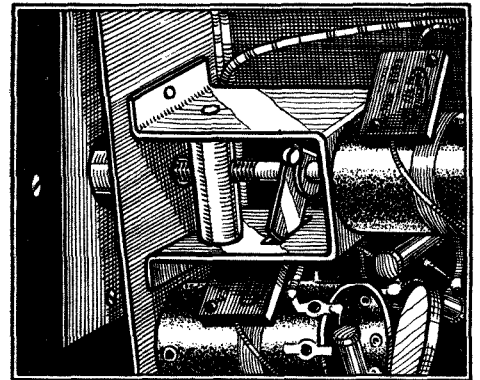

The adjusting screw for varying the inductance of the oscillator circuit is fitted with a tongue working in a slot which limits the movement to about three turns.

It is safe to say that the majority of prospective viewers already possess a good broadcast receiver, and if they have grown to know its little tricks of tuning and tone control and are satisfied with its quality of reproduction, they may not like the idea of having to accept a new instrument as make-weight in the new television set.

The Murphy A56V is as much a self-contained receiver as television is a self-contained service, and it can, if required, be installed in a different room from the existing broadcast set so that the two can be used simultaneously.

Murphy Radio have already had experience of building a television receiver (the A42V) without restriction as to cost. Most of the economies they have effected in the A56V are the result of the better valves which are now available and of the acceptance of a slightly smaller picture size.

Circuit.—The di-pole aerial feeder is tapped directly into the tuned aerial cir-

sary. The makers, through their service agents, are able to fit an accessory with the required attenuation when the receiver is installed.

Tuning is effected by varying the oscillator frequency. The triode section of the frequency-changer is arranged as a Colpitts circuit with inductance tuning by means of an adjustable metal plunger. The normal oscillator frequency is 40.75 Mc/s, giving intermediate frequencies for sound and vision of 750 kc/s and 4.25 Mc/s respectively.

The sound receiver is similar in general design to that of the A46 broadcast receiver, but has a wider bandwidth in the IF stage to take advantage of the good quality available from Alexandra Palace and to allow for a possible drift in the oscillator frequency. The double-diode-triode second detector supplies undelayed AVC to the IF valve and also acts as first AF stage before the output tetrode. Negative feed-back is incorporated in this stage.

Three stages of IF amplification are

break-through of the sound channel may be experienced. A diode rectifier follows the vision IF amplifier and feeds the single-stage vision amplifier, the anode of which is connected directly to the control grid of the cathode-ray tube. This ensures that the DC component will be retained under all conditions. The brightness control takes the form of a potentiometer in the cathode circuit of the cathode-ray tube.

Segregation of the synchronising impulses is effected by a double-diode valve fed from the cathode circuit of the vision amplifying stage.

Saw-toothed currents for the magnetic

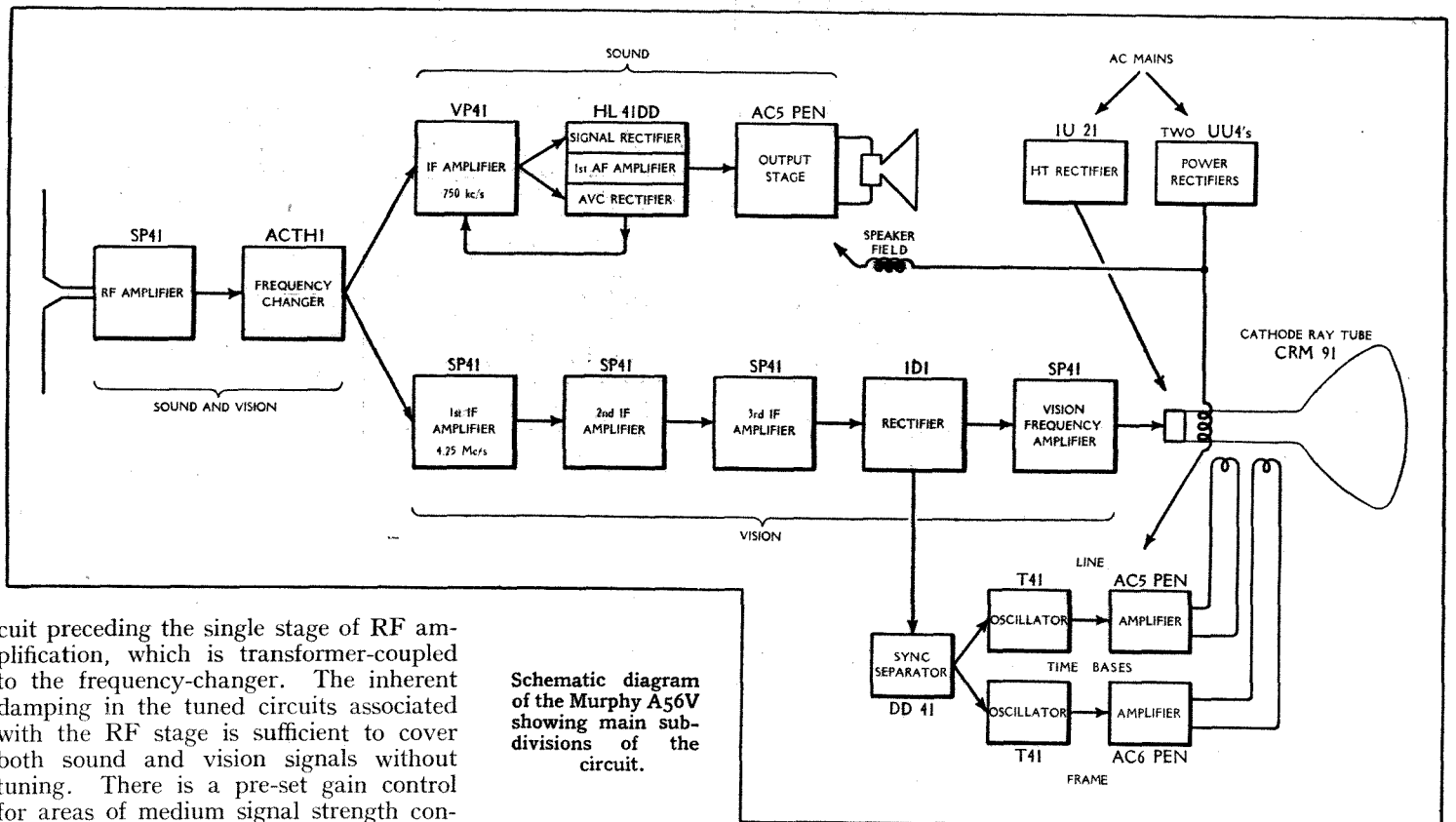

Schematic diagram of the Murphy A56V showing main subdivisions of the circuit.

cuit preceding the single stage of RF amplification, which is transformer-coupled to the frequency-changer. The inherent damping in the tuned circuits associated with the RF stage is sufficient to cover both sound and vision signals without tuning. There is a pre-set gain control for areas of medium signal strength consisting of a variable cathode bias resistance. In areas of strong signal strength this is hardly sufficient to prevent the formation of a vertical pattern on the picture due to cross-modulation between sound and vision channels, and an additional input attenuator becomes neces-

sary. The makers, through their service agents, are able to fit an accessory with the required attenuation when the receiver is installed. used in the vision receiver with a gain (contrast) control consisting of a variable cathode resistance in the first two stages. A tuned filter is connected in the cathode circuit of the first stage to introduce negative feed-back at the frequency at which

deflection of both line and frame time bases are generated by gas-filled triodes in conjunction with tetrode power amplifiers. An interesting method of ensuring linearity in the working stroke of the time bases has been devised and is dealt with

Murphy A56V—

in "Television Topics" in another part of this issue.

The power consumption of any television set is considerably greater than that of a broadcast receiver, and in this case two rectifiers with strapped anodes are used for full-wave rectification of the main power supply. After one stage of smoothing the current divides, one branch going through the loud-speaker field for extra smoothing, to the sound and vision receivers, the other through the focusing coil to the time bases. Suitable decoupling is provided to prevent interaction between the various circuits.

High tension of 4,700 volts for the anode of the cathode-ray tube is derived from a separate mains transformer and a half-wave rectifier valve with a cathode of large heat capacity to delay the application of the HT voltage until the remaining circuits have warmed up. To prevent damage to the screen after the set has been switched off and while a charge remains on the HT reservoir condenser, the mains switch is provided with contacts which increase the cathode bias resistance of the tube to limit the beam current. Once the set has been switched off it should not be switched on again until the HT rectifier

Principal controls of the Murphy A56V and view with chassis lowered into the horizontal position to show arrangement of valves and mounting of the cathode-ray tube.

range. The line and frame synchronising controls are not critical, and once set require no further attention.

Focusing is sharp and uniform up to the edges of the picture. The focusing control required much less attention than was expected in view of the fact that it is magnetic. By the time the valves had warmed up and the synchronising controls had been properly adjusted, the focusing coil current was sufficiently stable to hold its setting for the remainder of the transmission period.

too wide or too narrow. Normally a picture size of 7½ in. by 6 in. is obtained, and this is an admirable compromise for the range of viewing distances and the number of the audience which can be comfortably accommodated in the average living-room.

Constructional Details.—The end of the tube is framed in a moulded black rubber mask which is fitted over the tube itself. The chassis as a whole is hinged and in its normal position all components under the base are readily accessible. By removing two screws the chassis may be

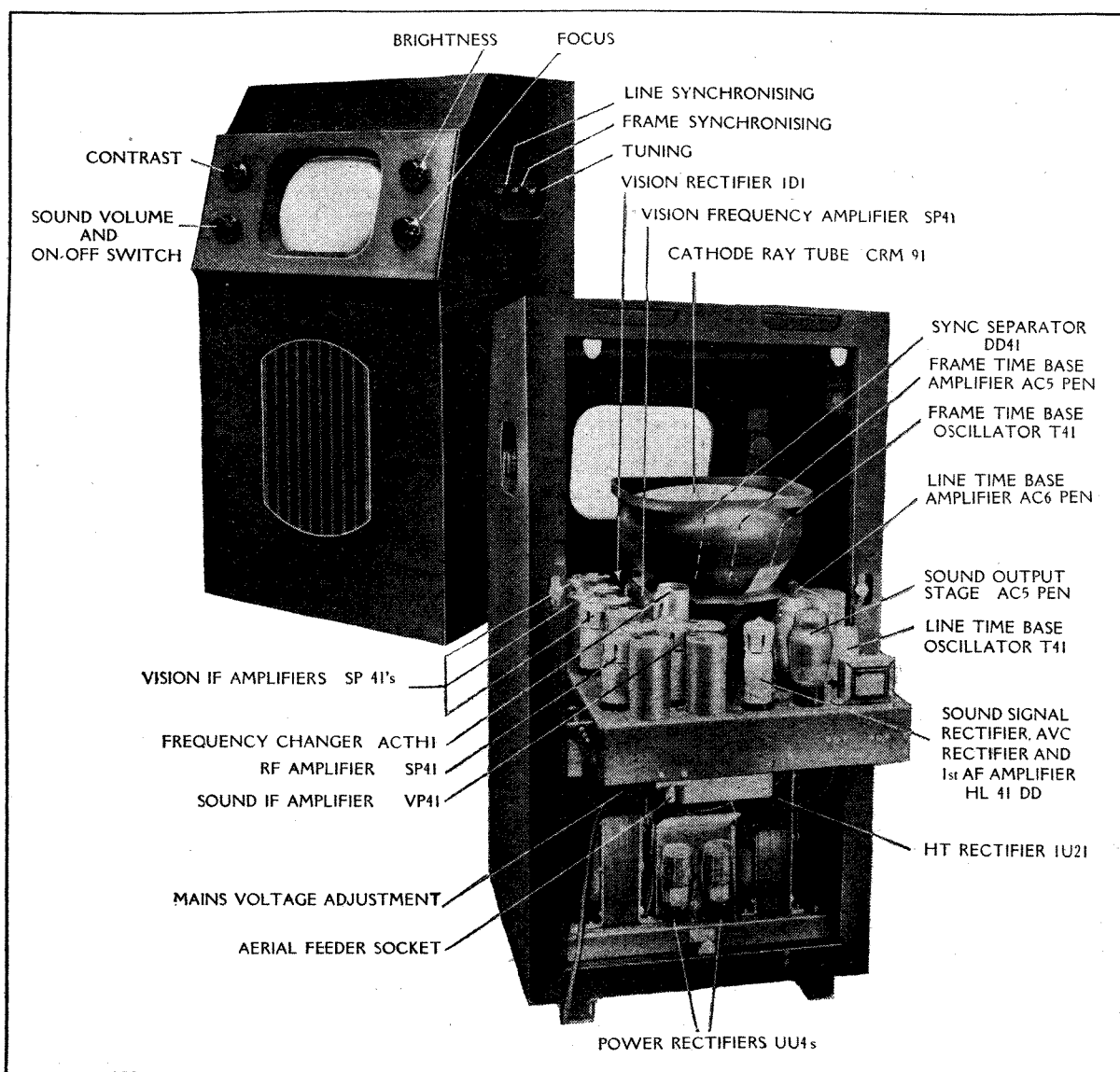

cathode has had a reasonable chance to cool down.

Performance.—The instrument was tested at a distance of six miles from Alexandra Palace on a di-pole aerial erected well clear of surrounding buildings. The signal strength was above the optimum for satisfactory operation and the makers supplied an input attenuator to eliminate the cross-modulation between the sound and vision signals.

We were very much impressed by the reserve of brightness in the picture, which enabled it to be viewed in comfort in daylight. The contrast control was well able to cope with the corresponding adjustment required of it, and all the controls of the instrument are notable for their wide

Definition is excellent and the breaking up of the lines into closely spaced dots due to some break through of the vision intermediate frequency is not at all objectionable and gives the effect of a half-tone reproduction.

A 10 in. moving-coil loud speaker of the type used in the Murphy A38 receiver is employed in the sound channel and quite easily reveals the superior quality associated with transmissions from the Alexandra Palace studios.

There are rather more than the usual number of tapings on the mains transformer as the set is more sensitive to changes of HT volts than an ordinary broadcast receiver. Errors of adjustment may be suspected if the picture is

lowered into a horizontal position for valve or tube inspection.

The cathode-ray tube passes through a hole in the chassis and the wiring of vision frequency and time base circuits is thereby reduced to a minimum. This method of construction enables a very compact cabinet to be designed as well as facilitating adjustment and servicing. All connections to the chassis, including those to the controls on the side of the cabinet, are flexible, and it is possible to work the set in the horizontal position.

Summary.—The A56V very happily fills the gap between the larger and more expensive combined television and radio receivers and the cheap table models with small tubes. In size, brightness and

Murphy A56V—

quality the picture is much nearer the performance of the former than the latter class of instrument. The controls are as easy to work as they are simple in appear-

ance. In relation to the circuit specification, the quality of components and the performance, the price is very reasonable, and appears to have been fixed in advance for future quantity production.

AIRCRAFT WIRELESS

Keeping Pace with Modern Aeronautical Developments

IN the days before broadcasting commenced, and in the early days of broadcasting itself, we were accustomed to listen for aircraft wireless mainly on a wavelength of 900 metres, but as in other spheres of wireless communication, aircraft has now "gone short wave." The necessity for long-distance communication is partly responsible for this, but there are other conditions peculiar to flying which have played an important part in the matter. These points and also a great deal of other interesting data concerning problems which beset the designer of aircraft wireless were discussed in a paper recently read before the Institution of Electrical Engineers by N. F. S. Hecht.

At one time the only aerial known aboard an aeroplane was the long trailing wire, usually of some 200 or 300ft. in length. There were always certain difficulties connected with this device, but none of an insuperable nature until really high-speed aircraft were developed. The result of speed was that the aerial was trailed almost completely horizontally instead of taking up the familiar downward curve. It thus lost practically all its vertical component, this resulting in a very serious reduction of range; in addition it became very liable to foul the aircraft structure.

The Aerial Problem

The above difficulties led designers to consider the question of fixed aerials stretched over or under the fuselage. As the latter formed the wireless counterpoise or earth, the effective height of the aerial was very restricted, being less than two feet in the case of small aircraft. The use of long and medium waves, therefore, became no longer possible with any degree of efficiency, although it should be mentioned that they are still employed to some extent and in certain circumstances by large aircraft and flying boats. In such aircraft medium waves are used up to about 300 miles, short waves being employed at greater distances, and it is quite a common arrangement for a trailing aerial to be employed for the short distance medium wave transmissions, a change being made to a fixed aerial for long-distance SW work.

In recent years the practice has been adopted of using dipoles connected through the usual matching transformers and transmission line. Frequently arrangements are made to use this type of aerial on medium waves by connecting the di-

poles so that they act as the two limbs of a T aerial. Aircraft aerials are subject to a great deal of vibration and, in addition, at high altitudes are liable to ice-formation. Both these factors are liable to cause breakages, and special measures are taken to counteract them. Ice-formation on insulators is another enemy to efficient wireless communication which has had to be tackled by designing protective cowls for these components, and by other measures.

Another serious effect of aerial vibration, apart from mechanical strain, is that, in the case of short-wave CW working, excessive frequency wobble is produced. Although mechanical measures such as shock absorbers were sufficient to relieve the ordinary physical strain, no great improvement in the matter of frequency wobble was brought about until self-oscillators and direct aerial coupling were abandoned in favour of the master-oscillator system, which designers, at one time, showed a great reluctance to adopt in view of the necessity of keeping down bulk and weight.

Interference Elimination

Noise is one of the bugbears of the air, and considerable research has been directed towards producing suitable designs of helmets containing microphones and earpieces. It is necessary that the helmets should be efficient for their purpose without bringing in their train other troubles not directly connected with wireless. Perhaps some idea of the difficulties that have had to be overcome will be had when it is stated that in certain aircraft the noise level at the operator's unprotected ear reaches a value of 135 phons or one million times that observed in the carriage of an express train. Some difficulty was experienced in preventing the microphone picking up and transmitting aeroplane noise along with speech. This was tackled by arranging to restrict the audio-frequency range to as great an extent as possible compatible with speech intelligibility. Actually it was found that if frequencies below 700 c/s and above 2,500 c/s were eliminated, speech intelligibility was still maintained satisfactorily and the transmission of unwanted noises greatly reduced.

With regard to purely electrical noise generated in the aircraft itself, it need hardly be said that all the well-known anti-interference measures are extensively used. Among the electrical noises pecu-

liar to aircraft are those due to the existence of bad electrical contact between rubbing parts such as cross-over points in straining wires, and such-like. In some cases the cure has been effected by careful bonding although, in the case of the wires already mentioned, insulating acorns have had to be used to keep them permanently apart.

Another point of interest is the provision of soft-iron cases for headphones in order to prevent interference with the magnetic compass. Prior to the adoption of soft iron, deviations up to about 20 deg., with the headphones at a distance of 18in., were experienced. Soft iron cases reduced this to 1 deg. at 6in. The soft iron cases are moulded into an insulated covering to prevent the wearer receiving a shock through some accidental connection with high voltage circuits, and for the same reason a mica disc is placed over the iron diaphragm.

Fire Precautions

Fire is an ever-present danger in aircraft, and remarkable care is taken to use adequately insulated cables and components, and to carry out very careful bonding. The accumulator circuits have been found to be the most likely source of fire owing to excessive surface leakage over acid-splashed areas, and much protective work has been done by the provision of unspillable and splash-proof accumulators and by fitting insulating separators between the latter and the containing crates. Lightning is, contrary to popular opinion, comparatively innocuous, and it has been found that little need be done beyond a careful "earthing" of the aerial when in a storm area.

Lowered atmospheric pressure at high altitudes is a frequent cause of trouble due to corona losses over the surfaces of insulators and at sharp points. Long leakage surfaces and the avoidance, as far as possible, of excessively sharp points are the remedies adopted. The lowered temperature of the upper atmosphere can, however, cause serious frequency drift due to contraction of certain components. Transmitting inductances are the chief offenders, and a goodly measure of improvement was obtained by the use of copper tubing shrunk on to heavy supports built up of a homogeneous material, but better results were had by the use of bi-metallic conductors, silver and copper being the principal metals used. The most obvious cure for this trouble is the employment of crystal oscillators, although it means the use of several of them in order to cover different wavebands.

In recent years the receiver has been coupled to the common transmitting/receiving aerial by means of a small condenser of high insulation. The transmitter is permanently connected to the aerial, and thus the aircraft transmitter can be automatically set to the frequency of the ground transmitter as the operator tunes in the signal from the latter. This ensures accurate setting of the transmitter, without the necessity of carrying a wavemeter.

Television Topics

LINEAR SAW-TOOTH OSCILLATOR

NOT the least of the difficulties encountered in the design of television equipment is the attainment of a linear saw-tooth waveform for scanning. Whatever form of time-base oscillator is employed it is usual to adopt a resistance-capacity charging circuit, and it is commonly arranged on the lines shown in Fig. 1. Here a gas-triode oscillator is shown, but other types can be used.

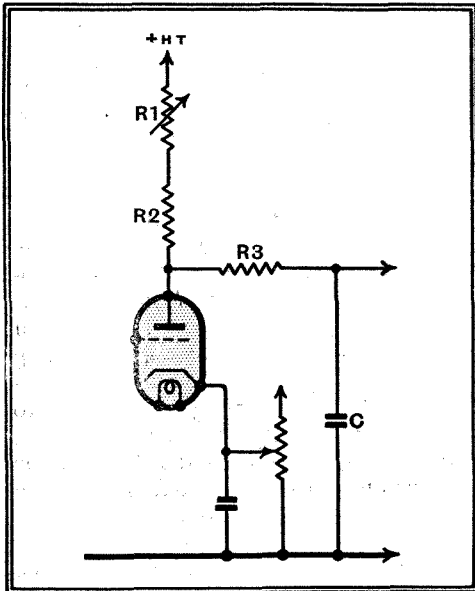

Fig. 1.—The conventional gas-triode saw-tooth oscillator.

When the valve is non-conductive the condenser C charges from the HT supply through R1, R2, and R3, and the voltage across it rises exponentially. The sync pulse at length arrives, and changes the grid potential in a positive direction; the valve becomes conductive, and the condenser discharges through R3 and the valve resistance. These are so low in value that the discharge time does not exceed about one-tenth of the charging time. R3, in fact, is only included to limit the discharge current to a safe value for the valve.

The voltage waveform across C is of the form shown exaggerated in Fig. 2(a), whereas it should be linear as in (b). In practice, exponential charging is satisfactory if the amplitude of saw-tooth voltage is small enough in relation to the HT voltage, for the initial portion of an exponential curve is nearly linear. It is desirable that the saw-tooth amplitude should not exceed 7 per cent. of the HT voltage.

There is usually no difficulty with electrostatic deflection, because the HT supply is of the order of 1,000 volts, and it is rare for more than 50 volts amplitude to be

needed. With magnetic deflection, however, the HT supply is generally only about 300 volts, so that no more than 20 volts amplitude of saw-tooth waveform can be secured.

Now this is generally too small. In the first place, the amplifier often needs a greater input, especially if negative feedback is used, and, secondly, saw-tooth oscillators usually operate much more regularly when giving a reasonably large output than when the output is small. It is not uncommon to find, therefore, that the oscillator is made to give an output of 30 volts or so, and that the curvature of the waveform is corrected by designing the following amplifier to introduce an equal and inverse curvature.

This is by no means as easy as it sounds, and a particularly interesting method of overcoming the difficulty has been adopted in the Murphy A56V and A58V receivers reviewed elsewhere in this issue. Correction is used, but it is obtained in the saw-tooth oscillator itself and not in the amplifier.

The arrangement for the line oscillator is shown in Fig. 3. It will be seen that it is the same as Fig. 1, but the charging condenser is split into two parts, C1 and C2, and an extra resistance R4 and condenser C3 are added. The output is taken across C2 and C3.

The operation is most easily followed by starting, with the condensers charged to their normal maxima, at the instant the gas-triode becomes conductive. All condensers then start to discharge for the fly-back. C1 and C2 in series discharge rapidly through R3 and the valve resistance, but C3 can discharge relatively slowly because of the high time-constant C3 R4. Actually, C1 and C3 are of the same order of capacity, and R4 is several hundred thousand ohms.

When C1 and C2 are discharged to their

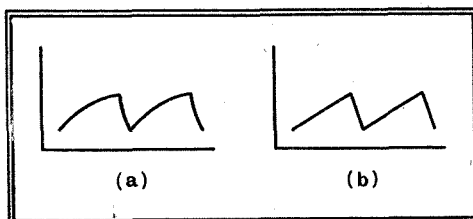

Fig. 2.—The usual exponential waveform is shown exaggerated at (a) and the ideal linear waveform at (b).

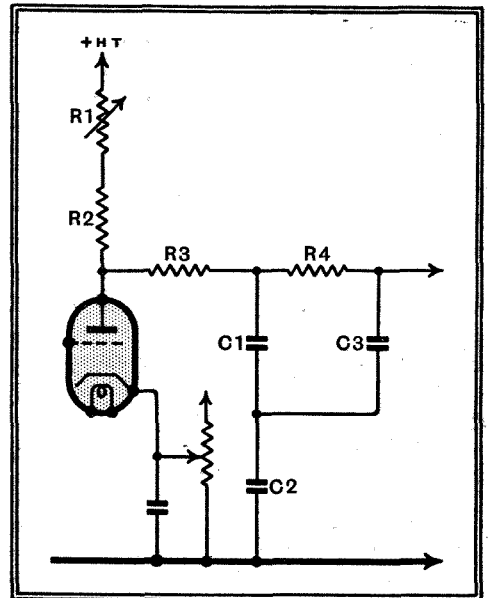

Fig. 3.—The oscillator circuit used in Murphy receivers is shown here.

normal minimum and the valve becomes non-conductive, C3 is by no means discharged. C1 and C2 then start to charge again through R1 and R2, but as the voltage across C3 is greater than that across C1, C3 still continues to discharge, and C1 takes its discharge current which thus helps to charge C1. The voltage across C1 is rising, and that across C3 is falling, and they at length become equal; the discharge of C3 then ceases. After this the voltage across C1 exceeds that across C3, with the result that C3 starts to charge again.

The result of this is that while there is a more or less normal exponential saw-tooth wave across C2, there is a semi-circular wave across C3, as shown in

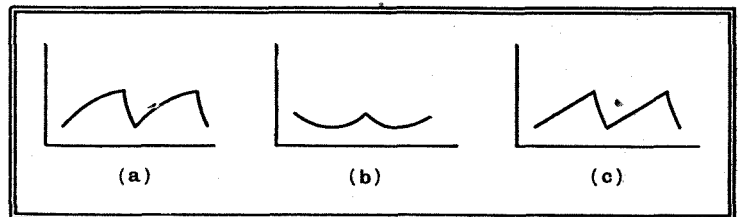

Fig. 4.—The usual exponential waveform (a) is obtained across C2 of Fig. 3 and the semi-circular wave (b) across C3. The output wave (c) is linear and is the sum of (a) and (b).

Fig. 4(a) and (b) respectively. The output voltage is the sum of the voltages across C2 and C3, and takes the linear form Fig. 4(c).

Of course, there are limits to the amount of correction it is possible to apply. There is still a maximum set to the output obtainable with reasonable linearity, but this is considerably higher than with the simple circuit of Fig. 1.

In the frame oscillator Murphy Radio use a similar circuit, but the values are so chosen that there is a large amount of over-correction. This is done to compensate for the distorting effect of the finite inductance of the output transformer in conjunction with the impedance of the deflecting coil. At frame frequency this is largely resistive.

UNBIASED

By FREE GRID

A Maritime Mishap

EASTER is now a thing of the past, and it is no fault of the P.M.G. that I'm not in the same boat. Boat is certainly the most appropriate word to use as it was actually in a boat that I nearly came to a sad and watery end. I am very keen on DF work and have been experimenting on and off for a very considerable period and enjoying the hospitality of a friend's yacht for this purpose. Needless to say, I used the Easter recess for the purpose of furthering my experiments.

I almost invariably use the carrier of the 500 kW. Moscow No. 1 station on which to test my gear, as this station is on the air for most of the twenty-four hours. I have spent several week-ends experimenting in the crowded waters of the Solent, achieving such a marked degree of success that I have been able to navigate blindfold, and have amazed some ships' captains by passing right under the bows of their vessel during the densest fog, and, in some cases, calling forth vituperation from them, as sailors are very superstitious folk and they probably mistook me for the Flying Dutchman, or some other ghostly visitant.

During the Easter week-end, however, I found myself all at sea in more senses than one as the carrier of the Moscow station gave bearings at almost all points of the compass, and before I knew where I was, I found myself ashore, and my name and address were being taken by a bucolic constable for allowing my bowsprit to col-



A collision on the King's Highway.

lide with a car on the King's Highway. It was only when I returned to London and talked the matter over with the Editor of this journal that I tumbled to what I feel sure was the cause of the trouble.

As you will have seen in *The Wireless World*, the G.P.O. are to use the Moscow wavelength for one of their wretched wired wireless transmissions, and, although this service has not started yet, experimental work undoubtedly has. Some time ago the G.P.O. announced that they proposed to

experiment in the Southampton area, and although this project was nipped in the bud at the time, it is obvious that some dirty work has been going on. Small as is the radiation of these overhead telephone lines there is no means of stopping it altogether, and it must be remembered that to get the Moscow carrier I was using a DF receiver of very great sensitivity indeed.

An International Conspiracy

I DARE say that, in common with myself, a great many of you suffer from extreme reluctance to get out of bed in the morning. It is, of course, a malady which affects both young and old and is especially virulent at this time of the year when we know that all the clocks are an hour fast, and that, by a Government subterfuge, we are all being forced to get up an hour earlier than usual. However, the malady has become so acute with me this year that I consulted a doctor upon the matter, and to my surprise he informed me that his surgery is daily crammed with patients who are suffering from the same complaint.

By pure chance I believe I have got on the track of the cause of it all, and have incidentally unearthed an international conspiracy of the first magnitude to increase the burden of our lot. I happen to have staying with me a retired ship's captain who, through sheer force of habit, insists on shooting the sun and stars at all hours of the day and night in order to ascertain his position. To his surprise, no less than my own, he made the startling discovery that my house was not always in the same place, a considerable variation in longitude being noticeable at different periods of the 24 hours.

Naturally, I questioned the accuracy of his calculations and made a point of calling into consultation some yachtsmen of my

acquaintance. They at first derided the captain's statements and ascribed them to the effects of strong drink, but, later, when they reluctantly consented to check them over with their own sextants they made the amazing discovery that not only my house but those in every other locality were oscillating violently from east to west. As everybody knows, in order to determine longitude it is necessary to have a precise knowledge of the time, but, in these days

of wireless time signals and frequency-controlled AC mains clocks, this presents no difficulty.

Now, it is the very fact that the question of accurate time is in such an apparently unassailable position that has made me doubt it. By careful observations I have discovered that all our watches and "clockwork" clocks are gaining heavily in the daytime and losing at night. Even so, I might have accepted the explanation that ordinary clocks are notoriously erratic, but, as far as I can find out from the fitful bursts of sunshine we get in this country, our sundials are also varying from hour to hour, and I am only waiting for sunnier days to come along to confirm my theory that there is an international conspiracy afoot to get more work out of us by the simple expedient of slowing down the frequency of AC mains—and, therefore, the clocks which they control—in the daytime and speeding them up at night, so giving us longer working hours and shorter sleeping time.

After all, the AC mains clock is so ubiquitous nowadays that it is simple for



An amazing discovery.

a thing like this to be done. At present this is only a theory, but I am hoping that you will assist me in gathering the necessary evidence to expose this vast time-robbing conspiracy to which, of course, the authorities who are responsible for the wireless time signals must be party.

An Unscrupulous Selling Dodge

THIS Budget business is all very vexing to a person of a methodical turn of mind like myself. During the few days preceding it I had been at great pains to discover, through certain sources known to me, whether any wireless taxes were to be imposed. As a result of the information I received—and for which, incidentally, I paid a tidy sum of money—I laid in a considerable stock of valves and HT batteries, which I learned were to be the subject of excise duties. It now appears that the rumour was deliberately promulgated by certain unscrupulous valve and battery manufacturers. The result is that I have a considerable stock of batteries and valves for which I can have no possible use for some time to come. I do not mind the valves so much, as, after all, they will keep, but it is very different with batteries. I met with a blank and uncompromising refusal when I approached the dealer from whom I had bought them, asking him to take them back into stock.

The AVC Characteristic

AN AID TO RECEIVER TESTING

By M. G. SCROGGIE, B.Sc.,
A.M.I.E.E.

WHEN testing a receiver by means of a signal generator to find out if all is well, it is usual to check the sensitivity at various frequencies, and perhaps also the selectivity. It does not seem to be generally realised, however, that one of the most informative tests is taking an AVC curve. Perhaps this is because when taken by the commonly prescribed method it is *not* very informative. The official instructions are to adjust the output of the signal generator, modulated the usual 30 per cent., to 1 volt (which is impossible with many good generators), and to set the volume control of the receiver so that a quarter of the rated maximum output is delivered. Leaving the volume control at this position, the signal is then successively reduced and the corresponding outputs noted. Fig. 1 is a curve taken in this way.

There is nothing in such a curve to show what the output of the receiver is with a given signal strength and volume control setting. The latter is unspecified. No indication is given of the correctness or otherwise of the AVC delay voltage. For the sensitivity at that frequency it is necessary to look up other data. The lower part of the curve is often difficult to measure owing to the smallness of the output. But before making other

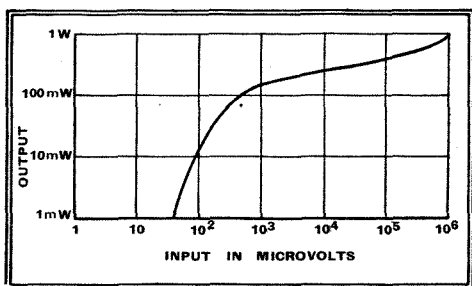

Fig. 1.—Typical AVC characteristic as measured at a frequency of 1,000 kc/s by the descending signal strength method.

criticisms it would be better to explain the method used with complete satisfaction by the writer throughout the last six years. It is carried out in the reverse order. The volume control is turned right over to maximum. If any output is shown, due to internally generated "noise," before the generator is connected, the amount is noted. Next the signal is applied, beginning from zero. The strengths in microvolts required to give outputs of 1, 3, 10, 30, 100, etc., milliwatts is recorded. To be midway

between 1 and 10 on a logarithmic scale the intermediate point should really be $\sqrt{10}$, but in this sort of work 3 is near enough for the error to be immaterial. Weak signals are measured with the volume control at maximum, which is the easiest and most accurate condition. It also corresponds to working conditions; and it automatically covers the sensitivity test, another piece of information omitted from the official scheme.

If the test were continued to the end with the volume control at maximum, in most receivers the results would be vitiated by overloading of the output stage. To avoid this, when an output somewhere in the region of a quarter of the nominal maximum is reached it is reduced to one-tenth by adjustment of the volume control. If necessary this is repeated, perhaps more than once, at higher inputs. This process, although it

corresponds much more closely to the way the receiver is actually used, appears to provide the only possible argument for advocates of the other method of test, on the supposition that it involves more work than moving the range switch of the output meter. In practice this argument has no weight, because by moving the range switch one stud back with one hand and simultaneously keeping the deflection constant by moving the volume control with the other, the adjustment is a matter of perhaps 2 seconds. And instead of giving a vague result, the volume control setting is definitely known throughout the test, and the signal level can be traced through the receiver and the figures used for checking the correct operation of all the stages. Thus there is actually economy of effort.

The results for the receiver concerned in Fig. 1 might be entered like this:—

Output : mW measured	Output : mW plotted	Input : μ V
2	2	0
3	3	14
10	10	22
30	30	30
100	100	47
300 } 30 }	300	70
100 } 300 } 30 }	1,000	120
	3,000	270
100	10,000	1,800
300	30,000	360,000

The two places where brackets are used are, of course, the points at which the volume control was readjusted.

The figures in the second column show the output power that would be given if overloading of the audio-frequency section did not take place.

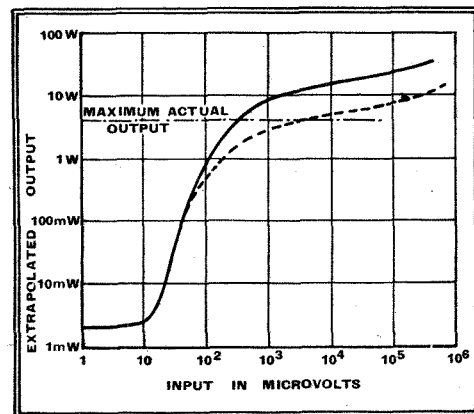

Fig. 2.—AVC characteristic, again taken at 1,000 kc/s, obtained by the ascending signal strength method. Valuable information on the design is revealed, including the desirability of reducing the delay voltage to alter the characteristic to the position shown by the dotted line.

When plotted they give Fig. 2. Although superficially very similar to Fig. 1 resulting from the alternative method of test, the only information that can be derived from Fig. 1 is that the AVC takes control at about 30 μ V input and above that is quite up to average effectiveness for a normal type of receiver with 3 controlled stages; whereas the following additional information is given by Fig. 2:—

(1) The output power corresponding to any signal strength and volume control setting. For example, a 10-millivolt signal modulated 30 per cent. and with the volume control set at one quarter voltage (one sixteenth in power) would give an output of about 1 watt. Modulated 60 per cent., and neglecting distortion, the output would be 4 watts, but as the nominal output for this receiver is 3½ watts there would be some overloading. The remaining threequarters of the volume control would merely intensify the overloading. The only signals for which volume control maximum could be tolerated are those that are so weak as to be below the point where AVC operates. Therefore, the greater part of the volume control range is useless, due to excessive AVC delay voltage. A more satisfactory result would be given by dropping the flat part of the curve to the dotted position.

(2) The approximate decrease in delay voltage required is given by the square root of the power ratio between the full and dotted lines. In Fig. 2 the power is to be reduced to about a third, so if the

The AVC Characteristic—

present delay voltage is 6 it should be reduced to $\frac{6}{\sqrt{3}}$, or 3.5. This calculation is more accurate with high level detection, where the delay voltage is considerably greater and more nearly equal to the peak voltage at the detector.

(3) A check is given on the design. Suppose the audio amplifier requires 2.5 volts peak to give full output: that corresponds to $\frac{2.5 \times 100}{30} = 8.3$ volts IF peak (modulated 30 per cent.) applied to a perfect detector, or $\frac{8.3}{0.8} = 10.4$ volts, assum-

ing 80 per cent. detector efficiency. The AVC voltage corresponding to that output should, therefore, be a little less than 10.4 minus the delay voltage.

(4) The sensitivity can be seen to be 35 μ V for 50 mW output. If there are three AVC-controlled stages and an AF stage, this is not very good at 1,000 kc/s.

(5) The lower part of the curve is obtainable, because it is measured at volume control maximum, unlike the other method of test (Fig. 1) in which it was necessary to cut down the power to one-seventieth throughout the whole range of signal strength. It is often not convenient to measure outputs smaller than about 1 mW., and even if the meter is sensitive enough there is a likelihood of error due to hum. The lower part of the curve is of special interest when testing a receiver with QAVC. If the slope is not practically vertical, due to instant throwing off of the muting, there is a likelihood of weak-signal distortion.

(6) The 2-mW noise output is recorded. This is definitely excessive for the type of

New McMichael Receivers

THE same cabinet has been adopted for the Model 391 and Model 398 AC and battery 4-valve superheterodynes. It is larger than the average table model and the specification includes many features not to be found in the low-priced categories. The "Clear-curve"

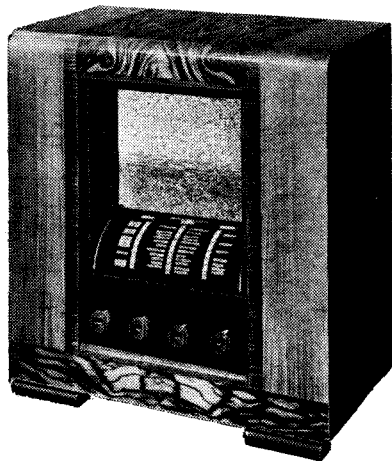

tuning scale has been designed for easy reading from any angle, and an improved four-position tone control combines variable selectivity in the IF circuits with controlled negative feedback in the AF stages. The price of the Model 391 is £12 5s., and of the Model 398 £11 5s., less batteries.

set that it appears to be, and in conjunction with the poor sensitivity suggests insufficient aerial coupling.

For these reasons, then, and from extensive practical experience, the second method of test is strongly recommended. The resulting characteristic contains so many clues to the performance of the receiver that it is well worth including as a routine test in the laboratory at least. For large quantities it might be quite practicable to rig up an automatic cathode-ray tester, which if operated at a fixed cyclical speed would, in addition, show up abnormalities in the AVC time constant as a departure from the normal separation of upgoing and downcoming curves.

Random Radiations

By "DIALLIST"

U.S.A. Television Starts

BY the time that you read this, at least one regular service of television broadcasts will have started in the United States, for the N.B.C. had long been planning to make its bow by televising the opening of the World's Fair at New York. When I say "a regular service" I'm thinking only of the 441-line, 50-frame system, which will be the standard in the U.S.A.; actually, services of a more or less experimental kind with varying number of lines and frames have been carried on for some little time in different parts of the country. The Don Lee station, W6XAO, has, for instance, been running daily 300-line broadcasts on 45 Mc/s (vision) and 49.75 Mc/s (sound) for several months at Los Angeles. This station is quite a giant amongst the smaller plants, for its vision output is rated at a whole kilowatt; there are not a few which range between 15 and 125 watts.

A Useful List

Though I knew that plans had been made to start television broadcasts in America, I'd no idea that there were so many stations contemplated or already in being until I saw the list in the May *Radio News*. It contains 19 stations already licensed and three which have applied for permits. Some of these, however, are of minute power output, whilst others, classed as portables, are apparently meant to provide the radio link for television O.B.s. Still, if we eliminate these and allow only the stations to rank whose vision output rating is one kilowatt or more, the list remains quite an imposing one. Here it is: W3XEP (30 kW), Camden, N.J.; W2XBS (12 kW), New York; W2XB (10 kW), Schenectady, N.Y.; W3XE (10 kW), Philadelphia; W2XAX (7.5 kW), New York; W1XA (3 kW), Bridgeport, Conn.; W6XAO (1 kW), Los Angeles, Cal.; W9X2V (1 kW), Chicago; W2XDR (1 kW), Long Island City, N.Y. I haven't included the 1.5 kW W9XG of West Lafayette, Indiana, because its wavelength of 150 metres doesn't appear to indicate high definition.

The wavelengths (yes, they are shown as wavelengths and not as frequencies) appear-

ing in the list are all very much shorter than ours. For most of the higher-powered stations the vision and sound channels are in the neighbourhood of 6½ and 4 metres respectively. The 10-kilowatt W2XB, though, is to use channels close to 4½ metres for both sound and vision. To the portable stations and radio links still shorter wavelengths are assigned. W3XAD is to work on about 2½ metres, W2XBT on 3 for vision and 1½ for sound, W3XP on 1½ and W2XD on 1.4. It will be extraordinarily interesting to see what kind of service areas these very short wavelengths give.

Funny if it Weren't So Sad

WE'RE making a little progress in the anti-interference campaign; but it's slow, regrettably slow. In 1937 a standard specification was published for apparatus that could be considered as not interfering with wireless reception. It was then announced that a mark would be registered and placed on apparatus that conformed to the standards. Now, nearly two years later, the mark has been registered, and a very pretty design it is. But only "in due course" (and you know what that means!) will apparatus sporting the mark become available. Time, it is said, must be allowed for manufacturers to dispose of their existing stocks; in other words, vast numbers of interference-producing apparatus must be unloaded on to the public and installed by it in its homes before the campaign can begin! The whole business would be laughable if it wasn't so sad. Why in the name of fortune have the manufacturers built up these stocks when they knew two years ago that the mark was coming along?

Portables Booming in U.S.A.

SOME months ago I reported, if you remember, that America had discovered the portable wireless set, which was then being advertised over there as the latest and greatest discovery in radio. I now hear from a friend in America that the portable has definitely caught on in the States. It didn't do so years ago when an accumulator had to be used for filament heating. I don't quite know why, though possibly Americans, used to mains receivers, couldn't be bothered with an LTB or "A battery," as they call it, which required periodic recharging. The introduction of the low-consumption filament in battery valves, which now makes it possible to use a single dry cell in place of the accumulator, has changed all that. If the LTB runs down, replacements can be obtained anywhere, and it is only a matter of a couple of minutes to have the old one removed and another put into the set in its stead. I can quite understand the point of view of those who would not touch the portable when it required an accumulator, but welcome it with open arms (and purses) now that it can get all that it needs from dry cells. There is something so beautifully neat and clean about the almost foolproof dry cell.

Always Useful

Not that I object myself to an accumulator in a portable set—provided, of course, that it is either unspillable or of the jelly-acid type. Ever since there were portables (and they go back a good few years now) I've always had one by me and I wouldn't be without it. In my home I have aerial and earth points in three rooms. I suppose I ought to have taken leads to the bedrooms as well; but one so seldom wants wireless

in a bedroom in the ordinary way that it didn't seem worth while. It's simpler and far less trouble, anyhow, to rely on the portable to bring the programmes into bedrooms in times of illness and convalescence. And then when you're going away for a holiday a light and compact portable is easily taken with the rest of the luggage. You're quite sure too, that it will work when you get to your destination, whereas you can't be certain that a mains set will, even though it be of the AC/DC type. Before now I've struck such unexpected snags as supplies with a voltage of 100 or so, to say nothing of noisy DC mains or AC with a periodicity of 25 cycles.

The Wavelengths

IT doesn't look as if the channels allotted at the Montreux Conference would have any very adverse effects on the service areas of our home stations. Two channels show increases in wavelength: Droitwich goes up from 1,500 to 1,511 metres and the London, Northern and Scottish Nationals from 261.1 to 262.9 metres. All of the other wavelengths are shorter, the biggest drops being suffered by the West Regional and Penmon (373.1 to 344.4 metres), the London Regional (342.1 to 327.5 metres), Northern Ireland (307.1 to 285.4 metres) and the Midland Regional (296.2 to 276 metres). But wavelength decreases should be more than offset by the promised increases in power; in fact, they may in one way prove beneficial by compelling the B.B.C. to get down to its programme of improving and rebuilding stations sooner than it would otherwise

have done. It's perhaps a little hard on the radio industry that it has been decided to introduce the new plan next March. Set makers will have to decide whether to print the names on their tuning dials in the old positions this autumn and include free issues of new dials in the spring, or to anticipate the Plan by arranging their dials according to its provisions when their new models appear.

Europe's Listeners

THE figures showing the numbers of licensed radio listeners in all European countries which were recently published by the I.B.U. make interesting reading. They show that for the whole continent the increase during 1938 was actually very nearly as great as in the previous year. There is naturally some slowing up in the rate in countries such as France and our own, which are in sight of the saturation point. But against that may be set the notable speeding up of the expansion of listeners' numbers that occurred in Italy (25 per cent.), Finland (27 per cent.), Romania (25 per cent.), Estonia (35 per cent.) and Turkey (110 per cent.). The fact that Turkey's listeners more than doubled their numbers was no doubt due to the opening of the high-power long-wave station at Ankara. Wireless in Italy seems at last to have turned the corner, though the 25 per cent. increase means an addition of only 200,000 to her listeners. At the end of the year Italian licences still totalled less than one million, despite the fact that the country has for some time had one of the largest and most efficient broadcasting systems in Europe.

Accessories and Components

WILLIS WORLD CLOCK

THE junior model of the Willis World Clock, which shows at any instant the time in the principal countries and on any of the standard meridians, is now available in skeleton form for incorporation in receiving

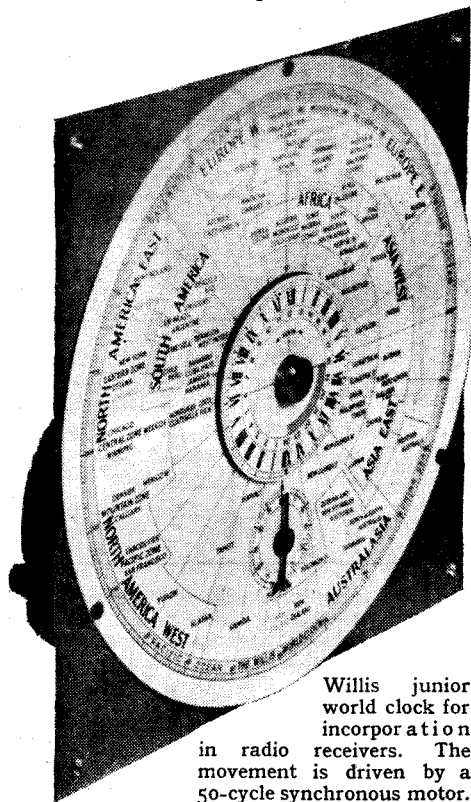

Willis junior world clock for incorporation in radio receivers. The movement is driven by a 50-cycle synchronous motor.

sets. The hour dial revolves anti-clockwise and carries a red sector showing the part of the world which is broadcasting its evening programmes. A subsidiary hand gives the time to the nearest minute.

The makers are J. H. Willis and Co., Ipswich Road, Norwich, and the price of the movement without case is £1 18s. 2d.

TAYLOR SIGNAL GENERATOR

THE specification of this instrument includes most of the features to be found in the more expensive standard signal generators. It has a frequency coverage of 100 kc/s to 46 Mc/s divided into six ranges calibrated in frequency. On five of the ranges, i.e. up to 23 Mc/s, the fundamental of the RF oscillator is used and on the sixth the first harmonic.

Variable internal modulation at 400 c/s up to 50 per cent. is provided, and a switch enables an external source of AF to be used. The 400 c/s internal supply is also available for testing amplifiers and the modulation control then functions as an output volume control.

The metal case measures only 12in. x 8in. x 6in. External leakage is negligible for all practicable purposes. A screened output lead is supplied and a special lead having the characteristics of a dummy aerial is available at an extra charge of 7s. 6d. The 400 c/s output is taken from a telephone jack, and a pilot lamp is fitted to show whether the power supply is reaching the instrument.

The RF output is controlled by a continuously variable attenuator marked "Microvolts" 0-10, and a separately

screened multiplier increases the output in decade steps up to 0.1 volt. There are intermediate stops which should be ignored between the marked settings. No calibration chart is supplied, but the output

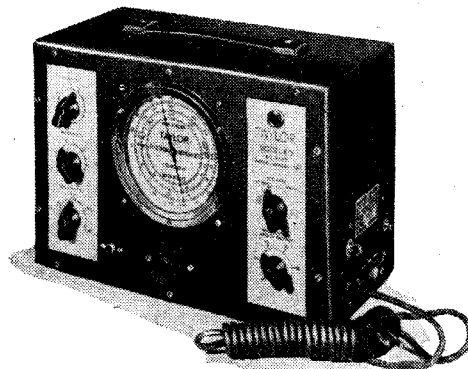

Taylor Model 60 all-wave signal generator.

approximates to the settings of the attenuator except on the "F" range, where the harmonic is much weaker.

A check on the AF output showed the maximum voltage on open circuit to be about 1½ volts. Most of the variation is in the first half of the volume control. The pitch is constant when the oscillator is used as a source of AF, but varies about a semitone over the range of the control when modulating the RF circuit.

The RF calibration is within the reading accuracy of the scales, which are from 2¼ to 3½ inches in diameter. The 400 c/s waveform is good and the instrument can be recommended for circuit alignment and the comparison of receiver performance. At 10 guineas it is not expensive. The makers are Taylor Electrical Instruments, Ltd., 77-77a, Queen Victoria Street, London, E.C.4

RESISTANCES FOR CATHODE-RAY CIRCUITS

ALTHOUGH not new, the multiple resistance elements made by Erie Resistor, Ltd., Carlisle Road, The Hyde, London, N.W.9, are being put forward as possible substitutes for the lengthy and often exposed string of resistors usually fitted in television receivers to discharge the high voltage smoothing condensers.

The resistor illustrated measures 2½ inches overall and is only 1¼ inches in diameter. It has a resistance of 20 megohms and will withstand 5,000 volts without flash-over.

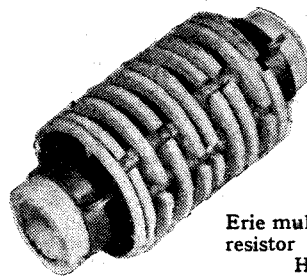

Erie multiple high voltage resistor for cathode-ray HT circuits.

The resistance elements are in the form of rings which are separated by flanged ceramic formers and connected non-inductively. Any number of units may be assembled up to a total length of 18 inches and the elements are of two types: Size A, 1¼ inches diameter, 1,000 volts per ring, 3½ watts per inch length; and Size B, ¾ inch diameter, 600 volts per ring and 1½ watts per inch length.

Their compactness and safety will commend them to manufacturers who realise that ordinary broadcast receiver standards of insulation are in the nature of a makeshift when applied to the high-tension side of television receivers.

Recent Inventions

The British abstracts published here are prepared with the permission of the Controller of H.M. Stationery Office, from Specifications obtainable at the Patent Office, 25, Southampton Buildings, London, W.C.2, price 1/- each.

ELECTRON-MULTIPLIERS

THE ordinary type of electron-multiplier has a very high output impedance—approaching infinity—so that it is impossible to deliver power efficiently from it to, say, a loud speaker or other low-impedance load.

According to the invention, this difficulty is overcome by making the last target electrode so that its emissivity is not uniform, but varies in a predetermined manner from point to point of its surface. This has the effect of making the characteristic curve of the device less steep and of providing a long straight-line "slope" over which the device can be operated.

As shown in the figure, the main electron stream passes from one target electrode T to the next in a series of curved paths, the current being increased in intensity at each stage by secondary emission. The last target T₁ is not uniformly emissive, as are the others, but a part of it (shown clear in the inset diagram) is coated with a more highly emissive material than the parts shown shaded.

Under working conditions the

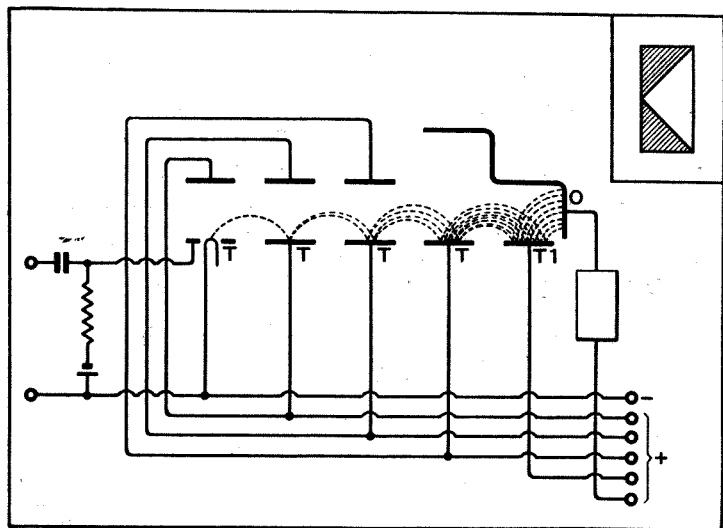

Decreasing the output impedance of an electron multiplier by means of a special construction of the final target electrode (shown in the inset).

stream will either fall mostly towards the right-hand side of the target, where the emissivity is greatest, or else mostly towards the left-hand side, where the emissivity is less, according to the output voltage on the collecting electrode O. In this way the effective impedance is made dependent upon the "sensitivity design" of the target T₁.

Marconi's Wireless Telegraph Co., Ltd., and G. B. Banks. Application date July 15th, 1937. No. 498843.

DIRECTIONAL AERIAL SYSTEMS

TWO spaced aeri-als, coupled in opposition to a common receiver, will pick up maximum signal strength from a transmitter which is in line with them, but will give minimum signal strength if the transmitter is situated at right-angles to this line. The well-

known Adcock aerial consists of two such pairs of spaced aeri-als arranged crosswise.

According to the invention, three or more such pairs of aeri-als are arranged symmetrically around the circumference of a circle, each pair being coupled to the corresponding field winding of a radio-goniometer, or to the similarly arranged deflecting plates of a cathode-ray indicator. This improves the sensitivity of the aerial system, and therefore adds to its effective range, and is used as an alternative to increasing the aerial height—which is undesirable in the case of an aerodrome installation. The operation of the system in direction-finding is also less dependent upon the accurate balancing of each pair of aeri-als, particularly as regards phase.

Standard Telephones and Cables, Ltd., and C. F. A. Wagstaffe. Application date July 9th, 1937. No. 498417.

Brief descriptions of the more interesting radio devices and improvements issued as patents will be included in this section.

coupling is tightened up, or as the tone-controls C and L are brought into operation. The shutters slightly reduce the volume of sound, but are stated to keep the higher and lower frequencies in the correct proportion to produce a

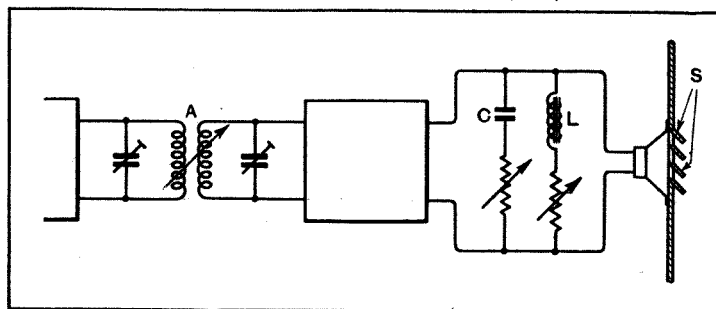

Combined electrical and acoustic tone-control.

pleasing effect, free from disagreeable overtones.

N. V. Philips Gloeilampenfabrieken. Convention date (Germany) May 10th, 1937. No. 499108.

PRODUCING SYNCHRONISING IMPULSES

THE invention relates to means for producing synchronising impulses at the end of each scanning line in a television transmitter. Although the method is of general application, it is illustrated in connection with a rotating disc scanner D and a cinema film F.

Light from an aperture O in the

MAKING MOSAIC-CELL SCREENS

A BUNDLE of fine aluminium wires, equal to the number of picture-points required on the screen, and coated with aluminium oxide, is firmly bound with metal rings, and is then cut up into thin slices, each of which forms the basis of the screen.

To complete its preparation, the surface of each slice is first etched so that the ends of the wires are slightly eaten away, leaving a corresponding number of small cups or recesses, surrounded by the projecting edges of the original insulating layer. The cupped wires

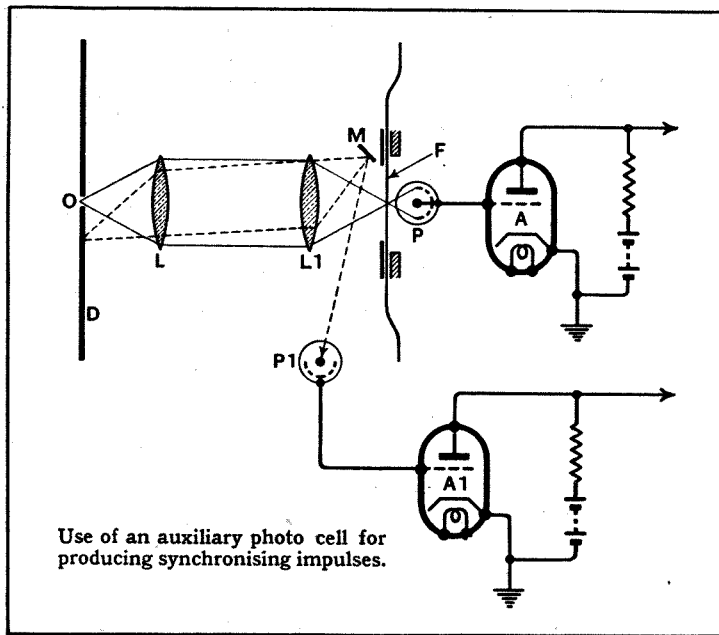

Use of an auxiliary photo cell for producing synchronising impulses.

rotating disc is focused on to the film by means of lenses L, L₁, and passes through the film to energise a photo-electric cell P, which is coupled to the signal amplifier A. As the ray reaches the end of each scanning line, it falls on to an inclined mirror M, from which it is reflected along the dotted line path on to an auxiliary photo-electric

are then made photo-sensitive by treatment with silver and caesium vapour. The aluminium oxide insulation may be further covered with a layer of graphite, which serves to screen the wires electrically from one another.

Radio-Akt. D. S. Loewe. Convention date (Germany) June 16th, 1936. No. 498672.

The Wireless World

THE PRACTICAL RADIO JOURNAL
29th Year of Publication

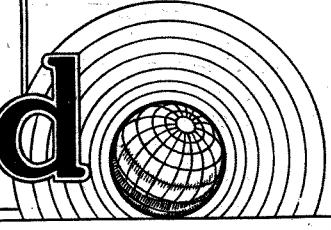
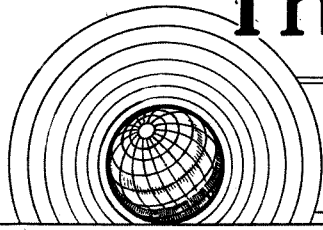

No. 1028.

THURSDAY, MAY 11TH, 1939.

VOL. XLIV. No. 19.

Proprietors : ILIFFE & SONS LTD.

Editor :
HUGH S. POCOCK.

Editorial,
Advertising and Publishing Offices :
DORSET HOUSE, STAMFORD STREET,
LONDON, S.E.1.

Telephone : Waterloo 3333 (50 lines).
Telegrams : "Ethaworld, Sedist, London."

COVENTRY : 8-10, Corporation Street.
Telegrams : Telephone :
"Autocar, Coventry." 5210 Coventry.

BIRMINGHAM :
Guildhall Buildings, Navigation Street, 2.
Telegrams : Telephone :
"Autopress, Birmingham." 2971 Midland (5 lines).

MANCHESTER : 260, Deansgate, 3.
Telegrams : Telephone :
"Iliffe, Manchester." Blackfriars 4412 (4 lines).

GLASGOW : 26B, Renfield Street, C.2.
Telegrams : "Iliffe, Glasgow." Telephone : Central 4857.

PUBLISHED WEEKLY. ENTERED AS SECOND CLASS MATTER AT NEW YORK, N.Y.

Subscription Rates :
Home and Canada, £1 10s. 4d. ; other countries, £1 12s. 6d. per annum.

As many of the circuits and apparatus described in these pages are covered by patents, readers are advised, before making use of them, to satisfy themselves that they would not be infringing patents.

CONTENTS

	Page
Editorial Comment	431
Electric Gramophone	432
Proposed New Amateur Code	436
Tubular Condensers	437
Television Programmes	438
Problem Corner	438
Frequency Doublers	439
Something New in Car Aerials	440
Orchestral Pitch	441
The Montreux Plan	442
Frequency Modulation in America	443
News of the Week	447
New Tone-Control Circuit	449
Letters to the Editor	450
Paper Records	451
News from the Clubs	451
Unbiased	452
Random Radiations	453
Recent Inventions	454

EDITORIAL COMMENT

B.B.C. "Official"

Public Reaction to Broadcast News

THE responsibility of British broadcasting towards the listener is, by virtue of peculiar circumstances, probably greater than that of any other agency through which news is conveyed to the public. The peculiar circumstances are that, however much the B.B.C. may try, it cannot remove from the public, and particularly listeners abroad, the deeply rooted idea that every statement in the nature of news made by the B.B.C. is either directly or indirectly expressing the opinion of our Government. The feeling exists almost universally that no matter what the news item may be, it has at least received the approval of some responsible Government official before it is transmitted.

We suspect that it is precisely with the object of trying to correct this impression and to emphasise the non-official nature of B.B.C. news that the Corporation so often includes irresponsible items ; but we think that some better means should be devised to achieve this object. The only effect of the present method is to cast a reflection in the minds of the public on the policy and capabilities of the Government.

Voice of the State

It is by no means easy to imagine how the combined opinion of listeners that the voice of the B.B.C. is the voice of the State can be changed, unless it is by constantly referring in B.B.C. news to the source of statements made. The fact that the news almost invariably follows a number of

purely official announcements tends to strengthen the opinion of the listeners that the news itself is officially approved.

If the B.B.C. confined its general news information to quotations from the morning and evening papers and indicated carefully with which paper the information originated, we believe that this would, to a very large extent, remove the present misconceptions. It would then be possible to add to the news so quoted other statements which if they were official in character could be expressly so described.

We believe that it is of the utmost importance that steps should be taken to remedy the present unsatisfactory position and to relieve the B.B.C. of the necessity of broadcasting transparently foolish items in a vain attempt to get rid of the official atmosphere now pervading its news broadcasts.

The "A" Code

Proposed Amateur Abbreviations

WE commend to the notice of all amateur transmitters the suggestion for a substitute for the "Q" code, put forward elsewhere in this issue. The "Q" code was originally devised for the marine service, and its compilers have quite rightly never made any attempt to provide abbreviated expressions for facilitating the exchange of experimental data between amateur transmitters.

If, as we hope, the present suggestion is received with favour the details of the code should be widely discussed, and, most important of all, the international aspect must not be forgotten. The temptation to provide abbreviations for every contingency must be resisted, as a code of this kind loses half its usefulness if it cannot be memorised in full.

HIGH QUALITY REPRODUCTION AND NEW IDEAS IN OUTWARD FORM

Electric

THE apparatus to be described is the result of a good deal of thought devoted to devising means for getting the best reproduction from gramophone records and therefore may appeal to readers of *The Wireless World*. Persons who have inspected it generally start off by considering it fantastic that eight valves should be devoted to gramophone purposes only,

ALL are agreed as to the extreme inconvenience of conventional apparatus for electrical gramophone reproduction, but few serious attempts have been made to evolve something better. Here at last is a "chair-side" amplifier that seems to provide a satisfactory solution to the problem.

can be treated more artistically by hand.

An essential requirement is that one must not be obliged to leap up every few minutes to change records or adjust the volume or tone. This means that the turntable and controls must be easily carried or wheeled to the chair side. The usual way of doing this is by means of a "playing desk" or its equivalent, consisting of a turntable, pick-up and volume control. Mains and pick-up leads are, of course, necessary links with the mainland. Having gone thus far, one might as well include the amplifier, for no extra leads are needed; in fact, one probable source of trouble is avoided by

available for a number of purposes for which a good radio-gramophone or the equivalent might not be sufficiently portable.

As it is taken for granted that the reproduction is to be of the highest possible quality, and sufficient in quantity for domestic needs, and perhaps a little more, the equipment is bound to be fairly heavy, and easy movement to the most comfortable chair is best achieved by putting it on wheels or castors. Then, to ensure that it is not banished to some remote part of the house as a cumberer of the ground during times of disuse, the best policy is to make it in such a form as will be accepted as a useful piece of furniture. Its position near the easy chair is further assured by clothing it in fabric (to match, if possible) rather than in easily damageable polished wood. This idea was encouraged by the discovery that even oak finish was over 50 per cent. more expensive than padded tapestry on deal, as well as being far less sightly and serviceable. The design shown here takes the form of an occasional seat or table when shut up; when open, the pick-up and controls are conveniently accessible from a low chair, and there are spaces for selected and used records respectively each side of the main

substituting loud-speaker leads for pick-up leads, the latter being very liable to introduce hum. Another point is that a satisfactory form of tone control is much more easily arranged when the amplifier is accessible. And if the apparatus is self-contained it is

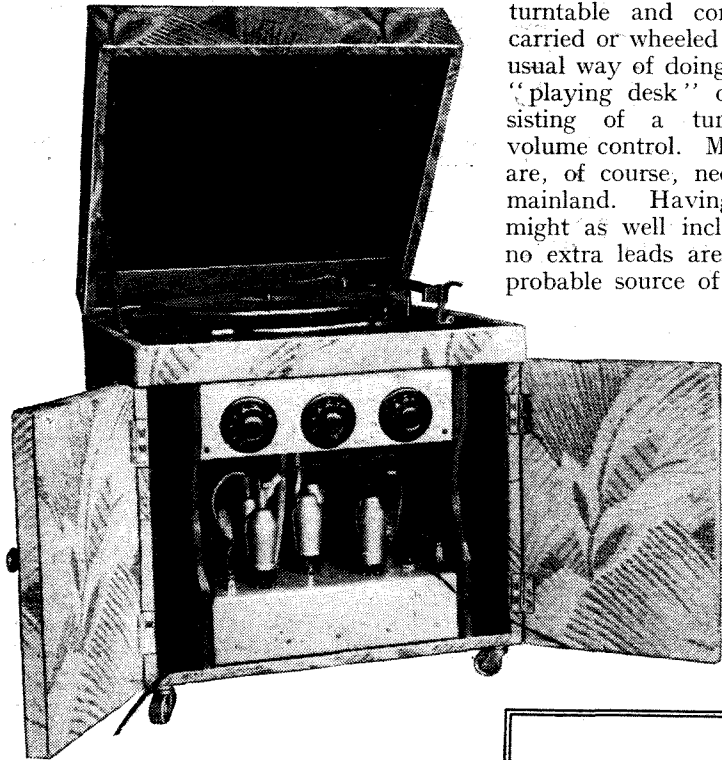

but by discussing the design step by step it is hoped to show that there is method in this madness.

First of all, it may be necessary to explain why the prevailing practice is not followed of combining gramophone with radio. The writer is not greatly enamoured of automatic record-changers, partly because of their tendency to utter various scratching and clicking sounds during the changing-over process, and partly because of the necessity for thinking out in advance the whole programme to be played. The advantages of the auto-changer seem to be mainly in providing a continuous service of sound which is supplementary to something else (such as dancing or drinking beer) and therefore is not listened to critically. In view of the fact that the disc record suffers greater potential limitations of quality than radio transmissions, its chief justification is the ability to call at any time on works of music performed by selected executants, and which merit attentive listening. In these circumstances records

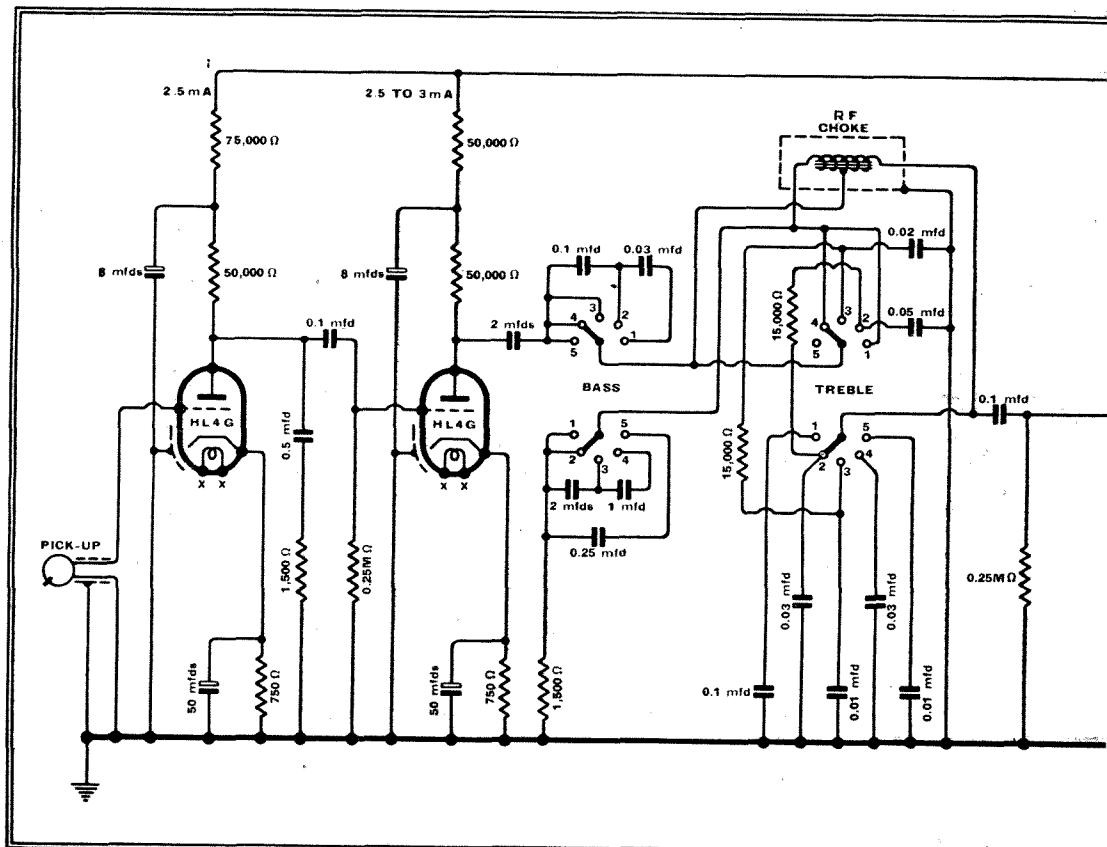

Fig. 1.—Complete circuit diagram of amplifier and tone control.

Gramophone

By
M. G. SCROGGIE,
B.Sc., A.M.I.E.E.

compartment. When not in use for this purpose these spaces are handy for storing the rather lengthy flexes that have been fitted for taking care of all contingencies.

As it is intended that the doors should be open when in use as a gramophone, it was not considered that any special provision need be made for ventilation. In case any readers are attracted by this cabinet, it may be mentioned that a very satisfactory job was made up to the writer's design by H. G. Dunn & Sons, Ltd., of Bromley, Kent, upholstered in selected tapestry, padded, at an inclusive cost of just over £4, and the firm is in a position to produce duplicates to order.

Choosing the Pick-up

There is nothing special about the turntable, which is a standard type driven by AC induction motor. The pick-up, however, called for more care in selection. The Telefunken T.O.1001 was finally chosen, because by adopting a sapphire point fixed in a diminutive armature it has been possible to avoid the usual needle resonance within the recorded range of frequencies, and hence not only to achieve a frequency characteristic that is substantially level throughout that range, but also extreme lightness and freedom. It is a vast convenience not to have to bother about needles, and a great comfort to know that record wear is negligible. A

little trouble was experienced with the first sample, which tended to engender certain obscure rattling sounds, but the replacement has been free from this defect. It is worth while taking some trouble to mount the pick-up accurately as instructed, and this is facilitated by the lining washers supplied. The sapphire point, which is almost microscopic, is ingeniously protected by a spring roller device, but it is advisable to take care in letting it down on any records that are chipped at the edges.

Coming now to the amplifier itself, the objects have already been mentioned, as regards quality and quantity, but the tone control, perhaps, needs to be emphasised. In the Telefunken pick-up no attempt is made, probably wisely, to compensate for the restriction of bass in the recording, amounting to as much as 15 db. at 50 c/s. Also, the sustained output right up to and beyond the top limit of recorded frequency causes the amount of scratch reproduced from most records by means of an amplifier with a flat characteristic to be unbearable. There seems to be a tendency to record the upper frequencies with a slightly rising characteris-

tic, which allows some reduction in scratch to be obtained while preserving the overall characteristic level; but generally it is necessary to sacrifice some "top" to obtain a reasonably silent background. Moreover, records differ very considerably in their balance of tone; so altogether a comprehensive tone control system is essential for getting the best out of them.

The bass compensation ought really to be regarded as over and above any adjustment available by means of the tone control, because it is only when the bass has been lifted 15 db. at 50 c/s that the overall characteristic (inclusive of the record itself) is flat. As this rise is as much as can be accomplished in any one

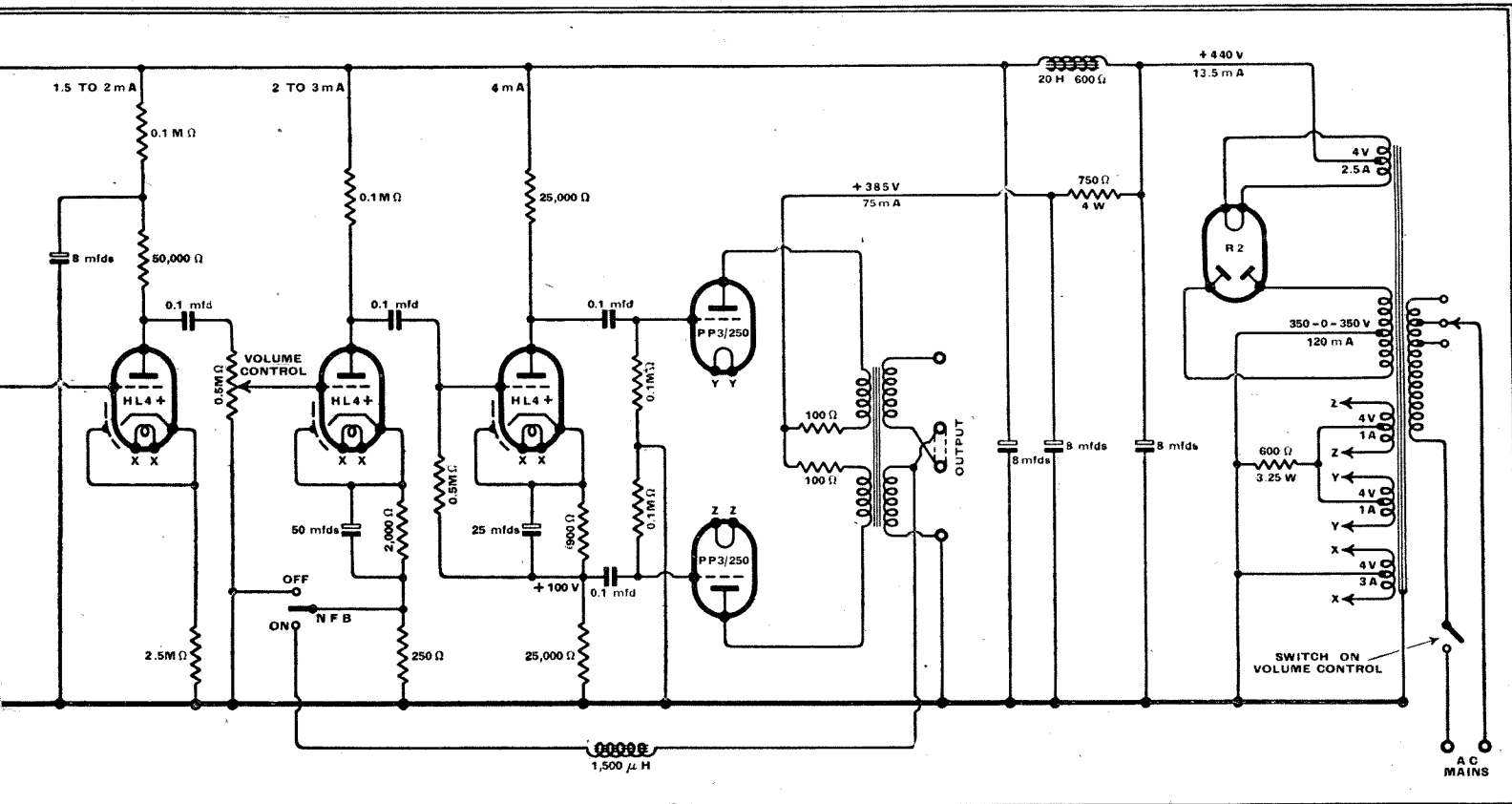
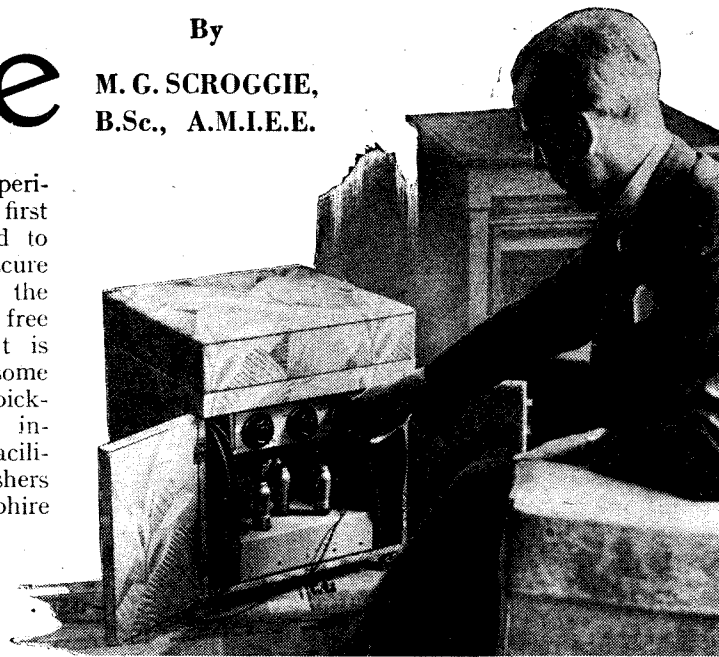

Electric Gramophone—

stage without the use of oscillatory circuits, it is best to do it separately from the tone control proper.

Leaving the subject of tone control for the moment and looking at the other end of the amplifier, there is the output stage. Modern tetrodes are attractive by reason of their power efficiency; but for the highest quality it is necessary to use negative feedback, which eliminates their other advantage of smaller drive voltage than triodes. Moreover, the efficiency and quality depend to a considerable extent on the load impedance being approximately right. Not only is it very convenient to be able to connect various loud speakers, singly or in combination, without having to think too hard about load matching, but the impedance of any one speaker varies largely with frequency. And although it is argued that tetrodes (properly used) distort no worse than triodes, nobody appears to have shown that they are any better. So, as the writer has been driven to the conclusion that the greater power output of multi-electrode output valves is largely illusory so far as the highest quality work is concerned, he conservatively stuck to triodes. As an output of about 7 watts was considered to be ample, a pair of PP₃/250 valves are

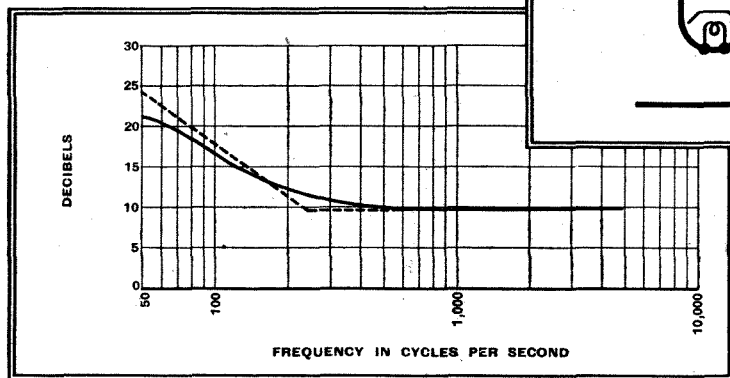

used. This is the actual measured output on the secondary side under the conditions of use; the theoretical output is slightly more.

Negative Feedback

Push-pull is justified on purely economic grounds, quite apart from its value in reducing the unpleasant components of distortion and difficulties of decoupling. Without it a much more expensive output transformer and smoothing system would be required. The use of negative feedback with triodes may be more surprising, especially as it is not for tone control purposes. As can be seen from the circuit diagram, it is optional and without it there is a reserve of amplification. Normally it is used, however, and reduces residual hum, renders the output even less dependent on load impedance, and cleans up the performance generally. There would be no point in applying the feedback over the output stage only, as it would be likely to cause more trouble than it cured, by increasing the signal level in the previous stage. It has, therefore, been

taken back to a point where the signal level is so small that even when increased it still comes well within the power of the preceding stage to handle without appreciable distortion. This also makes it possible to include the output transformer, too, as the low secondary voltage is enough for feedback. The amount of feedback actually used divides the amplification by slightly more than 4, equivalent to a loss of 12½ db.

To simplify the application of negative feedback over several stages, to minimise the opportunities for picking up hum, and to serve the interests of high fidelity and cheapness, resistance coupling throughout was adopted. This immediately raised the question of the phase-inverter. The method described by O. H. Schmitt (*Journal of Scientific Instruments*, March, 1938)¹ was given a trial, but the Cocking "concertina" circuit was finally preferred, because it remains balanced even

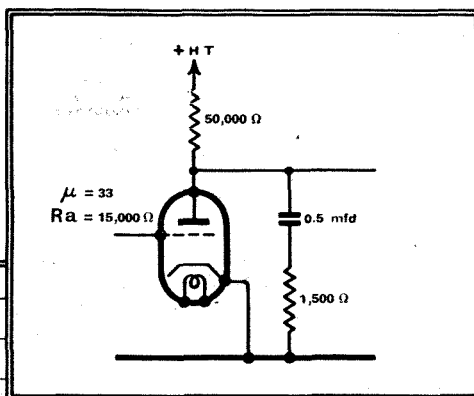

Fig. 2.—Frequency characteristic of the first stage, showing bass compensation. The dotted line indicates the theoretical requirement.

if the valve ages, it is less tricky to design and adjust, its gain is about 50 per cent. higher for two valves, owing to its feedback it is extremely linear, and although the available output is less it was found possible by careful design and the use of choke decoupling (avoiding large voltage drop) to get rather more than enough to drive the output stage. The cathode is 100 volts more positive than the heater, and as the Tungstram HL4+ valve is exceptional in being rated up to 150 volts difference, as well as requiring only 2.4 watts for the heater, it was selected for this and all preceding stages.

The phase inverter stage requires 43 volts (peak) to drive it; a straightforward preceding stage gives a gain of $\times 27\frac{1}{2}$, and, allowing for the negative feedback (which is conveniently introduced into its cathode circuit), calls for $7\frac{1}{2}$ volts at its grid.

Coming back now to the subject of tone control: one possible method is to insert frequency-discriminating circuits in the negative feedback line so as to reduce feedback at those frequencies which it is

¹ Since writing this, it has been dealt with in *The Wireless World*, April 13th, 1939.

desired to boost, and vice versa. This method was rejected because, although it is quite useful for moderate amounts of control, it does not lend itself to a steady rise of 6 db. per octave over as much as 2½ octaves, and greatly increases the risk of oscillation that is present when large amounts of negative feedback are attempted. So the method adopted is the well-known one of varying the coupling impedance in a stage of amplification. To obtain the required 6 db. per octave (which is the rate of bass loss in recording) it is necessary for the amplification of the stage to be directly proportional to the coupling impedance, and therefore the latter must at all frequencies be small compared with the valve anode impedance, which means that at some frequencies it must be very small. At such frequencies the valve amplifies only slightly, if at all; its amplification being reserved for those frequencies one desires to boost. Because of its very high anode impedance, a pentode is the best type of valve for large amounts of tone control; but in the present case two triodes were used, because one could be devoted to compensating for bass loss, leaving the other free for tone control proper.

Coupling the Pick-up

Now, for absence of linearity distortion a triode really ought to be worked with a comparatively high external impedance, and as the coupling impedance for tone control is very low at some frequencies, the expedient is sometimes adopted of increasing the valve impedance by connecting a resistance in series. This method makes it difficult to maintain the rise in amplification uniform over a sufficient range of frequency, so cathode-ray tests were made to find the maximum signal that could be handled under low-load impedance conditions without appreciable distortion. As expected, this was fairly low (about 0.3 volt input). The output of the Telefunken pick-up, which has an impedance of 100 ohms, is about 0.1 volt peak on normal records. A 1:20 ratio transformer is recommended for use with it to increase the output; but a valve is cheaper, and has the advantage of not needing the careful screening that is necessary to prevent a transformer at this low-level stage from picking up hum. Although the signal level is low when the pick-up is applied straight to the valve, the low impedance makes it very easy to avoid hum. And the extra gain makes the amplifier suitable for alternative use with a needle-armature pick-up or a microphone.

Because tone control of the type chosen must be carried out at a low-signal level to avoid distortion, it is evident that it must be dealt with right at the start, and the first stage is devoted to compensating for bass loss in the record. At middle and high frequencies the coupling impedance is effectively the 1,500-ohm resistance, as the impedance of the 0.5-mfd. condenser in series is negligible, and the anode and grid resistances of 0.05 and 0.25 megohm respectively merely reduce

Electric Gramophone—

the effective coupling resistance to a negligible extent. At these frequencies the amplification is approximately $\times 3$. But at low frequencies the major part of the coupling impedance is the reactance of the 0.5-mfd. condenser, which progressively increases as the frequency diminishes, and

After putting in the power rectifier, the full tale of valves is thus made up; and as they are all of comparatively cheap kinds and of a minimum number of types, no further apology seems necessary. Although it would be quite satisfactory for all valves previous to the output stage to be of the HL4+ type, the first two

and two degrees of cut on the other. Actually "Flat" is arranged to give a slight boost, to supplement the efforts of the first stage. The treble control presented more difficulty, because it was desired to be able to introduce a sharp cut-off at certain frequencies in order to combat scratch. At the same time it is most essential to avoid any tendency to a preliminary resonant peak, which is shock-excited by scratch frequencies and degrades the performance to that of inferior types of pick-up with their armature resonances.

Testing the Tone Control

As pure calculation of filters to a given performance is exceedingly tedious in all except idealised cases, the final adjustment was experimentally done with the help of cathode-ray apparatus improvised to show the frequency characteristic instantaneously on the screen. The effect of any adjustment could thereby be seen at once instead of only after a lengthy process of plotting separate points. As this apparatus was made up from what happened to be at hand, instead of being purchased ready-made for a mere few hundred pounds, it may be of interest, and the arrangement is shown diagrammatically in Fig. 3. A motor-driven variable condenser, made up from an old gramophone motor and other odd parts, happened to be left over from previous experiments with "ganging oscillators," and was, therefore, available, complete with synchronising contact, made once per revolution. The output of a beat-frequency oscillator was thus variable over a band of a few thousand cycles. The position of the band itself was, of course, variable by the normal frequency control. The motor

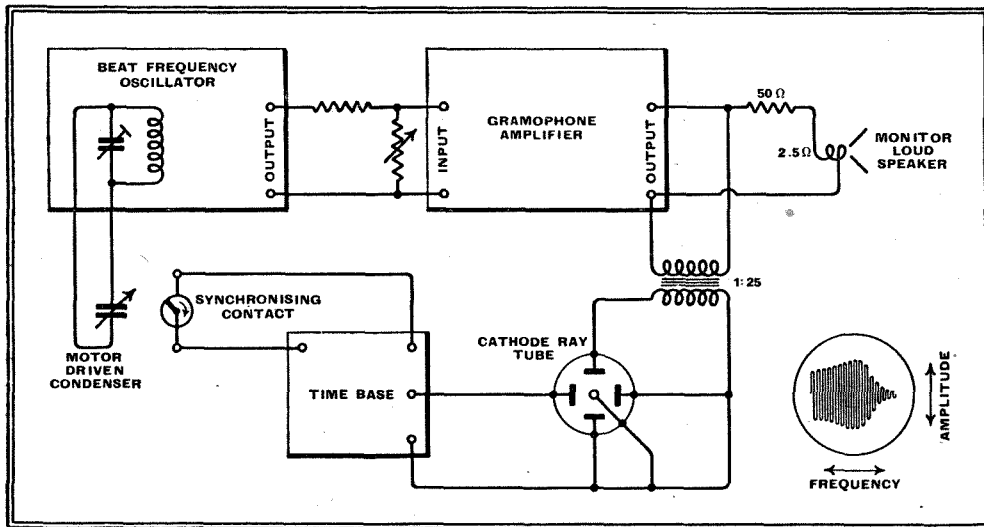

Fig. 3.—Diagram of apparatus used for studying the characteristics of the treble tone control. The inset shows the type of result obtained on the oscilloscope screen.

the amplification also increases in proportion until the anode resistance (effectively in parallel) exerts an appreciable shunting effect. Of course, the change-over, at 250 c/s, is not sharp, but, as can be seen from Fig. 2, the compensation is fairly close to the theoretical (and probably closer still to the inverse of the actual recording characteristic).

The second stage is similar, except that, instead of a fixed tone-compensating circuit, there is a variable tone-control system which will be described in detail presently. The normal gain of this stage (due to another 1,500-ohm coupling resistance) is again 3, so the normal maximum peak voltage given is about 0.9. To bring this up to the $7\frac{1}{2}$ volts required by the pre-phase-inverter stage, and to allow a little in hand, another stage is obviously necessary. As the full gain of a stage is needlessly large, it is reduced by the omission of the biasing resistor by-pass condenser.

Regulating Volume

Volume control has not yet been provided. To avoid overloading, the best place for volume control is as soon as possible—usually directly between pick-up and amplifier. On the other hand, for avoiding any noise, due to the volume control itself or to tone control switching, or any fault that might develop in the early stages, the later the better. As in the present case the maximum possible input is only slightly more than enough to overload the output stage with no reduction at all, it is quite safe to place the volume control in front of the fourth stage. It would, of course, be no use putting it anywhere beyond this, as the negative feedback would counteract it.

(HL4g) are actually of the same characteristics but modified by bringing the grid to a top cap and the metal coating to an independent pin. This confers minor benefits in further reducing any tendency to hum, and in making it possible to cut out the first stage immediately by clipping the input lead to the second valve top. This is useful, among other things, for non-gramophone purposes, for which the bass compensation is in general not needed.

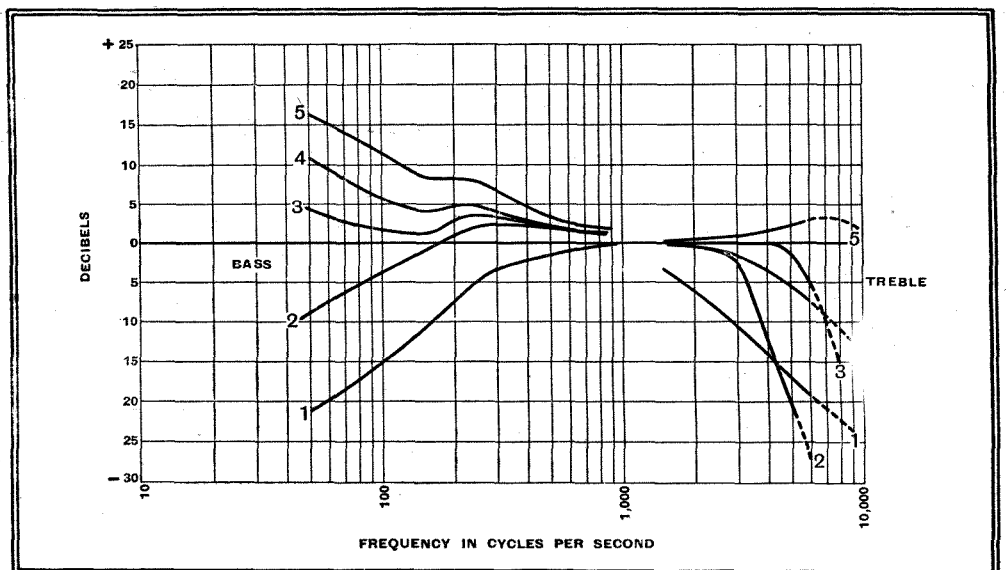

Fig. 4.—Measured frequency characteristics at different settings of the tone controls, inclusive of record, pick-up, amplifier, and output transformer. The characteristic of the record is level from 250 to 6,000 c/s, and falls 6 db per octave from 250 to 50. The sharp cut-off characteristics (2 and 3 on the treble side) are not so satisfactory aurally as 1 and 4.

The tone control system gives independent bass and treble control with five alternatives for each. The bass control is marked "Flat" in the centre position and gives two degrees of boost on one side

and time base were adjusted to run in synchronism at as slow a speed as possible—something like 10 c/s.

The system finally arrived at, and shown in the complete circuit diagram (Fig. 1),

Electric Gramophone—

consists of simple resistors and condensers except for a tapped choke made by centre-tapping a Varley screened iron-core RF choke (BP26). Some difficulty might be experienced in exactly duplicating this component, as the position of the tap is not very definite; but that matters little, because although the results (shown in Fig. 4) conform admirably to what was aimed at, they have served to demonstrate by the test of listening that for the best compromise between scratch and high quality, the sharp cut-off type of characteristic is less successful, even when free from appreciable resonances, than the steady droop. This is fortunate, because the latter is so much easier to calculate and construct, and for gramophone purposes the writer advises substituting the more conventional variations of treble tone for the two sharp cuts, 2 and 3. Rising characteristics—except perhaps for one very slight one—are not necessary or desirable if the system is to be used only with the Telefunken pick-up, but several degrees of fall, including a really drastic one, are helpful.

The frequency characteristics shown in Fig. 4 were taken with the help of the Decca EXP.55 standard frequency record, which is restricted uniformly below 250 c/s and therefore conforms to a theoretical rather than a practical characteristic; that is to say, one in which the level and falling parts meet in a sharp angle at 250 c/s rather than a smooth bend. This accounts for the irregularity in this region in Fig. 4. The dotted portions above 6,000 c/s have been filled in with the help of data from the cathode-ray apparatus. Apart from this, the curves are overall as far as the load—the record, pick-up, tone-control, amplifier, and output transformer characteristics being included. It should be noted that even with the most drastic treble reduction (No. 1) the note is brighter than when using some types of pick-ups with no tone control.

The Smoothing System

Finally, referring to a few miscellaneous features of the design, the absence of choke smoothing for the output stage will be noted. This greatly simplifies the problem of avoiding hum pick-up with a sensitive amplifier on the same chassis as the power system. The rectified output, 440 volts, is too much for the PP₃/250 valves, and the 750-ohm resistor serves the double purpose of smoother and voltage dropper.

The output transformer is wound with two identical secondaries, so, by connecting them in parallel or series, optimum load resistances of 2 ohms and 8 ohms are provided for. A number of loud speakers, each having several times these impedances, can be fed in parallel without any appreciable variation in the output from one speaker as the number in circuit is varied; and, unlike other types of output valve, triodes give even better quality when the load impedance is above normal.

The 100-ohm resistors in the primary side are for connecting a 0.5 voltmeter across for checking the static balance of

the output valves. The dynamic balance is ensured by using a common biasing resistor, un-by-passed.

The 1,500- μ H coil (actually a small iron-cored long-wave coil) in the feedback line was inserted because it was found that under certain dynamic conditions (such as a large amount of line capacity across the load) there was a tendency to momentary spurious oscillation.

The skirts of the tone and volume control knobs have grooves filed in them as markers and also to enable them to be operated by touch alone. The control panel is faced with matt white ivory. The power transformer is a Partridge T350/120.

The Goodman "Infinite Baffle" loud speaker, although specifically not recommended by the makers for gramophone purposes owing to its extended and rising high frequency response, actually gives very satisfactory results in conjunction with this set when a falling treble characteristic is selected. This type of speaker has the advantage (apart from good gen-

eral quality) of giving really low bass in a reasonably portable form—it is contained in an 18-inch cube. The whole equipment is, therefore, easily transportable in a small car for giving "sound" wherever wanted. The writer has used it very successfully in amateur dramatics, the audience being greatly impressed with the improvement over what is usually served up as music on such occasions.

Although the deficiencies of bad records can be "hushed up" by discreet use of the tone control, it is, of course, necessary to make a careful selection in order to demonstrate the capabilities of the apparatus. Lists of good quality recordings were published in *The Wireless World* some time ago, and the only one repeated here is a set of three which is attractive because it is of tuneful and varied music, brilliantly played and well recorded, inexpensive, covers a wide range of tone, and consists of short pieces necessitating no carry-over from one side to the next—the ballet suite "La Boutique Fantasque," recorded on H.M.V. 2846-8.

Proposed New Amateur Code

SAVING TIME AND REDUCING INTERFERENCE

A NEW and comprehensive code, expressly designed for the use of amateur transmitters, has just been submitted to the Radio Society of Great Britain.

This code comprises a series of over seventy 3-letter signals, planned to convey practically all the technical information, weather data, etc., that amateurs have occasion to exchange in the course of their transmissions.

The draft code has been drawn up by a Suffolk amateur, G3XT, of Stratford, near Saxmundham, who, though comparatively a newcomer to the ranks of transmitting amateurs, has had over fourteen years' experience of listening on the amateur bands, and is, therefore, conversant with amateur requirements as regards a signal code.

Simplicity and Speed

It is claimed that the use of the new abbreviations, each of which begins with the letter A (a letter that is quick and easy to key in Morse), will effect an enormous saving of time, as it enables any typical amateur message to be sent, accurately and explicitly, with approximately one-half the amount of signalling incurred under the existing system. The originator suggests that, by eliminating superfluous signalling, the new "A" code, if adopted, should do much to reduce the present interference on the amateur bands.

An important advantage of the proposed abbreviations is that they are ex-

ceptionally easy to memorise, as the last letter of each signal (with a few unavoidable exceptions) is the initial letter of the subject covered. "ATR?" for example means "What is your receiver?" "ATW" means "Please wait," "ASA?" means "What type of aerial are you using for transmission?" and so on.

Meteorological Data

A section of the code is devoted to weather data and conditions of reception. This affords a ready means of indicating, briefly but accurately, the prevailing weather and reception conditions on the band at the time of the QSO. The enquiry signal "AWX?" (meaning "What is the weather in your locality?") can be answered by abbreviations such as "AWR" meaning "The weather here is rainy," while more detailed information can be given if desired with the aid of the abbreviations AWB, AWT and AWV, referring to barometer readings, temperature and visibility respectively.

"AWA" meaning "Conditions of reception here are good," and "AWI," "Conditions improving," are among the signals intended to be used in reporting on the state of the band at any given time.

As the new code is sufficiently comprehensive to cover the whole field of amateur transmitting activities, it has been suggested that it could, if adopted internationally, supersede the present International Q Code as far as everyday amateur use is concerned.

Tubular Condensers

THEIR BEHAVIOUR AT RADIO FREQUENCIES

By F. R. W. STRAFFORD (Research Dept., Belling and Lee, Ltd.)

EXAMINATION of a rolled paper-dielectric condenser would suggest that it might have appreciable inductance; an obviously undesirable property for a component to be used for by-passing RF currents. After considering the various forms of construction, the author of this article reaches the conclusion that condenser inductance is negligible compared with that of the connecting leads. Useful information on the choice of by-pass condensers is given.

ATUBULAR paper-dielectric condenser is constructed by taking a long strip of special paper of appropriate thickness, to each side of which is attached a metal foil whose width is usually less than that of the paper. This assembly is wound into a tight roll and connections are taken out from each end of the roll. The whole assembly is usually impregnated with insulating compounds, waxes, etc., and enclosed in a cylindrical container of card-

board or similar material, the ends being sealed. Before the term "non-inductive" was applied to fixed condensers it was usual to connect to the foils at a single point only, somewhere on the length.

In a modern non-inductive tubular condenser this single-point connection is avoided by arranging the foils to overlap the edge of the paper so that during the winding process the edge of each foil is short-circuited back upon itself. Thus when the connection is made to the foil it may be regarded as connecting every point along the edge of the foil by a short route. Perhaps Fig. 1 will make this clear.

A Fallacy Exposed

Now in considering radio receiver condensers of this type up to, say, 0.1 mfd. in capacity the reduction of inductance

due to the connection method of Fig. 1 (b) may be considerable, but in practice the self-inductance of the condenser, whether connected by either method, is small compared with the inductance of the wires used for connection purposes, even when their length is reduced to, say, half an inch.

At first sight the reader might doubt this statement—an attitude excusable until certain somewhat obscure points are explained. It is a fact that we have a fairly long foil, perhaps six feet or more in length, rolled into a spiral, which makes us think of our textbook teaching on the enormous increase of inductance obtained by winding a conductor into a helix or spiral.

In the case of the tubular condenser it does appear at first sight that the same sort of thing will happen, but this can be disproved by the following argument.

Fig. 2 (a) depicts a conductor which may be in the form of a wire or a flat strip bent back upon itself with its inner faces nearly touching. Now if the ends A and B are the connections to the source of voltage the current flow as shown by the arrows is in opposition in each leg of the arrangement. Hence the magnetic flux is very nearly cancelled. For perfect cancellation the wires or foil would have to be infinitely thin and infinitely close to one another.

If zero magnetic flux threads this circuit there must, by definition, be zero inductance in that circuit and when the flux is very small the inductance is small.

If the loop is wound into a spiral or helix, Fig. 2 (b), there is no reason to expect the inductance to increase to any appreciable extent, since there is very little increase in flux linkage.

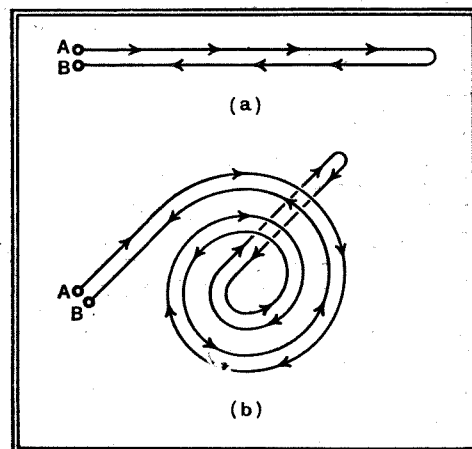

Fig. 2.—Diagram (a) shows a conductor bent back on itself; winding the same conductor into a helix, as in diagram (b), has a negligible effect in increasing inductance.

Fig. 3, and we now present the circuit of an unrolled paper condenser, in which each capacity may be referred to as the capacity per unit area of foil.

When an alternating potential is applied across A and B current will flow down each condenser circuit so that at any pair of opposite points along the foil, say at X and Y, the current will be equal and opposite. Hence the inductance will still be very small, in fact practically the same as when the loop was closed as in Fig. 2 (a). Similarly the same argument applies with regard to rolling the resultant circuit into a spiral—the inductance is inappreciably changed.

The foregoing should make it quite clear that there is no reason to expect large values of self-inductance in tubular condensers, particularly as the foils are usually separated by one- or two-thousandths of an inch, thereby providing an extremely closed form of loop and one through which very little magnetic flux can thread.

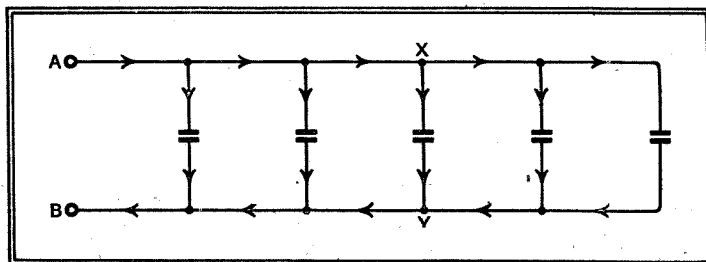

Fig. 3.—The equivalent circuit of an unrolled paper condenser

Neglecting resistance effects in the condenser and its connecting leads, the equivalent circuit of a tubular fixed condenser (or any other fixed condenser for that matter) will be as shown in Fig. 4. C is the capacity of the condenser, L is the inductance of the foils on the condenser,

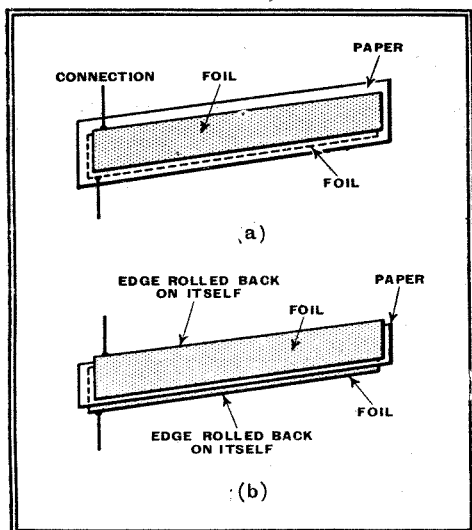

Fig. 1.—The two principal methods of condenser construction compared. Diagrams (a) and (b) show respectively the "inductive" and non-inductive types (both unrolled).

board or similar material, the ends being sealed. Before the term "non-inductive" was applied to fixed condensers it was usual to connect to the foils at a single point only, somewhere on the length.

In a modern non-inductive tubular condenser this single-point connection is avoided by arranging the foils to overlap the edge of the paper so that during the winding process the edge of each foil is short-circuited back upon itself. Thus when the connection is made to the foil it may be regarded as connecting every point along the edge of the foil by a short route. Perhaps Fig. 1 will make this clear.

Now in considering radio receiver condensers of this type up to, say, 0.1 mfd. in capacity the reduction of inductance

Tubular Condensers

and L_1 is the combined inductance of the two connecting leads, including the mutual inductance between them.

Careful measurements backed by calculations show that the inductance of the condenser itself is very small compared with the inductance of any connecting leads of useful length from the practical point of view. This statement holds even when the condenser is not wound in the so-called non-inductive manner, but is connected as shown in Fig. 1 (a).

It is obvious that there will be a frequency at which the inductance and capacity will resonate, and in these circumstances the impedance of the condenser between its two connecting extremities will be governed purely by the series resistance which is, of course, made up by the high-frequency resistance of the connecting leads, the resistance of the foils and the dielectric loss resistance referred in series with the condenser.

Aid to Choosing Values

A family of curves of this resonant frequency for a range of condensers, and for lengths of leads up to 16 centimetres

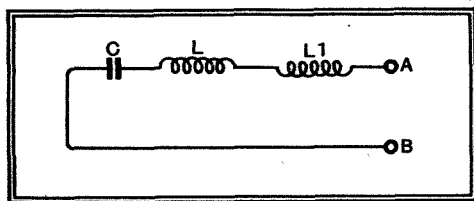

Fig. 4.—Equivalent circuit of a fixed condenser (neglecting resistance).

per head, has been prepared and is shown in Fig. 5. These curves should be very useful to designers of radio circuits and filters in that it gives the frequencies at which condensers of certain values and particular lengths of connecting leads commence behaving as inductances. In other words, a condenser should not be used at a higher frequency than the resonant frequency indicated for its particular capacity and lead length.

Instability in amplifiers employing several stages can often be traced to failure to take this fact into account, and as a general rule a condenser should not be employed at a frequency greater than half its resonant frequency as indicated from the curves.

On the other hand, if one is designing a circuit to handle one particular fre-

quency it might be desirable to so adjust the value of capacities and lead lengths to form filter circuits of the rejector type to work at the resonant frequency of the circuit, for by this means the effective

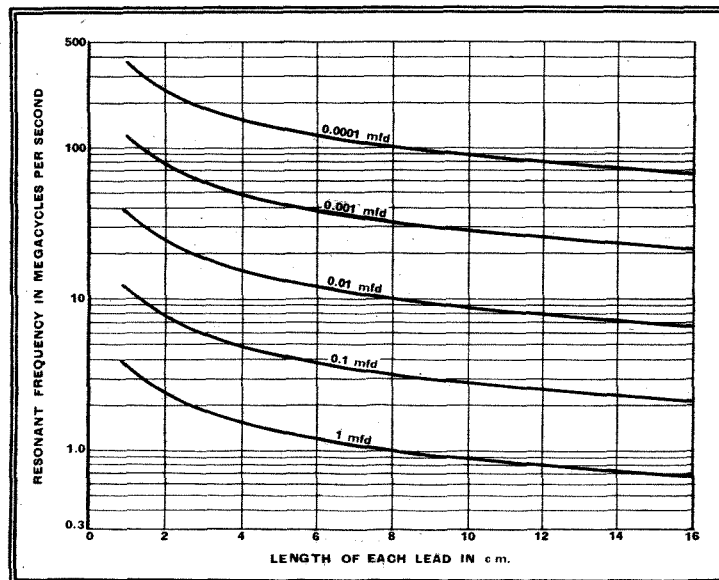

Fig. 5.—A useful guide to the choice of by-pass condensers: graph showing the resonant frequency of various capacities with 20-SWG leads of lengths up to 20 cm.

shunting value of the condenser is very much lower than would have been obtained by the calculated reactance, neglecting resistance and resonance effects.

Television Programmes

Sound 41.5 Mc/s

Vision 45 Mc/s

An hour's special film transmission intended for demonstration purposes will be given from 11 a.m. to 12 noon each weekday. The National or Regional programme will be radiated on 41.5 Mc/s from approximately 7.45 to 9 p.m. daily.

THURSDAY, MAY 11th.

3, Joan Miller and Polly Ward in "Pest Pilot." 3.30, Gaumont-British News. 3.40, 241st edition of Picture Page.

9, Renée Houston and Donald Stewart in Cabaret. 9.40, British Movietonews. 9.50-10.20, 242nd edition of Picture Page.

FRIDAY, MAY 12th.

3, Charlie Kunz. 3.10, "Foundations of Cookery," talk by Marcel Boulestin. 3.25, British Movietonews. 3.35, Wyndham Goldie in "Five At The George," a ghost play by Stuart Ready.

9, Trudi Binar—Starlight. 9.10, "Derby Secrets," No. 4—Film. 9.20, Marcel Boulestin. 9.35, Gaumont-British News. 9.45, "The Advantages of Paternity," a comedy by Horton Giddy. 10.15-10.25, Olga Coelho in Brazilian folk music.

SATURDAY, MAY 13th.

3, The Jacquard Puppets. 3.15, Gaumont-British News. 3.25, Cartoon Film. 3.30, "Spreading The News," a comedy by Lady Gregory.

9-10.30, Charles Heslop in "The Torchbearers," a satirical comedy by George Kelly.

SUNDAY, MAY 14th.

3, "The Conductor Speaks"—Sir Adrian Boult. 3.20, "Derby Secrets," No. 5—Film. 3.30, Yvette Guilbert—French disease. 3.40, O.B. from the Chelsea Flower Show. The cameras will be accompanied on their tour of the exhibits by C. H. Middleton, F. H. Grisewood and Elizabeth Cowell.

8.50, News. 9.50-10.30, Sybil Thorndike in "Sun Up," the play by Lula Vollmer. The scene takes place in a cabin in the mountains of North Carolina, June, 1917.

MONDAY, MAY 15th.

2.40, Chelsea Flower Show, O.B. 3, "Hungarian Rhapsody"—the Hungarian State Ballet from the Adelphi Theatre. 3.30, Gaumont-British News. 3.40, Film. 3.50, Eric's Wild Time. 3.55, Cartoon Film.

9, Carson Robinson and his Pioneers in Cabaret. 9.35, British Movietonews. 9.45, "Our Rough Island Story." 10.5, Charles Heslop—"In the Barber's Chair," No. 6. 10.15, Cartoon Film. 10.20-10.30, Basil Rodgers, the negro tenor with Henry Bronkhurst at the piano.

TUESDAY, MAY 16th.

3, Richard Hearne with Lily Palmer and George Nelson in "Take Two Eggs." 3.15, British Movietonews. 3.25, "In the Barber's Chair." 3.35, "The Advantages of Paternity" (as on Friday at 9.45 p.m.).

9, "Take Two Eggs" (as at 3 p.m.). 9.15, Peggy Wood—Starlight. 9.25, Cartoon Film. 9.30, Tennis O.B. from the Empire Pool, Wembley. Donald Budge, Ellsworth Vines, Bill Tilden and Nusslein in singles and doubles. 10-10.30, "The Deacon and the Jewess," a play by H. F. Rubinstein.

WEDNESDAY, MAY 17th.

3-4.30, "The Torchbearers" (as on Saturday at 9 p.m.).

9, C. B. Cochran's "Night Lights" from the Trocadero. 9.40, British Movietonews. 9.50, Sunday in the Country. 10.10, Cartoon Film. 10.15, Isabelita Alonso in Spanish Songs and Dances. 10.25-10.35, "Bridge without Sighs," in verse and cartoon by Reginald Arkell and Harry Rutherford.

PROBLEM CORNER—19

An extract from Henry Farrad's correspondence, published to give readers an opportunity of testing their own powers of deduction:—

Dear Mr. Farrad,

I hope you will forgive me for writing, but I am rather worried about our wireless. I remember you helped my husband in some difficulty he had with it a few months ago. Now he is away for a few weeks on business, so I have been taking advantage of that to do the spring cleaning. Of course, we had to move the wireless into another room for a day, but I was very careful and did it myself. There is nothing very complicated to do, because we use a "mains aerial plug," and I made sure that it hadn't come out. But the reception is nothing like so good as it was, and I am afraid John—my husband—will want to know what is the matter. I got a man to examine it, but he said it was perfectly all right; so now I am writing to see if you can suggest something, for which I would be very grateful.

Yours very truly,
Mary Frickton.

What did Henry Farrad suggest? See page 442.

Frequency Doublers

WHY THEY ARE USED AND SOME TYPICAL CIRCUITS

By H. B. DENT (G2MC)

IT is now almost universal practice in amateur transmitting circles to employ a master oscillator with the frequency stabilised by a piezo electric crystal in order to ensure that the transmissions shall be kept within the allotted band of frequencies. The oscillations generated by this stage need not be on the working frequency of the transmitter, which may be either two, four or eight times, or a similar multiple, of that of the master oscillator.

This is often a matter of convenience at working frequencies of 7 Mc/s or lower, and is only adopted if

facilities are required for operation on two or more wavebands, but frequency multiplication becomes an almost essential part of the equipment when transmission is effected on 10 and 5 metres and crystal control is employed. Crystals can, of course, be obtained for direct control of a 10-metre oscillator, but they do not operate on the fundamental frequency of the crystal, but on a harmonic of it.

These crystals are very useful in portable ultra-high frequency transmitters, but for a fixed station it is often better to employ a more robust crystal. Seven megacycles is about the highest frequency for which a crystal can be ground and which is sufficiently robust for normal use, even if it is possible to obtain crystals for fundamental operation on 14 Mc/s.

It was explained in a recent series of articles on the design of an amateur transmitting station that an RF output at twice the crystal frequency can be obtained

from the oscillator stage, and it was also mentioned that with only two valves in the transmitter sufficient RF power for short-distance communication could be effected on the fourth harmonic of the crystal frequency, i.e., in the 28 Mc/s amateur band.

THE amateur wavebands are harmonically related, and so it is possible, by applying the principles of frequency doubling, to use a single quartz crystal to control transmissions on several frequencies.

The efficiency of the output stage operated in the manner described was, however, not very high, being of the order of 30 per cent. only, as compared with 50 to 60 per cent. when it was used as a Class "C" ampli-

fier. At 56-60 Mc/s the efficiency is even lower.

In a fixed station and where economy in valves does not have to be considered the best practice is to multiply the frequency of the master oscillator until the desired operating frequency is reached and the output can then be applied to a power amplifying stage of the Class "C" variety.

In the case of a five-metre transmitter in which a 7-Mc/s crystal is used the frequency must be multiplied eight times to reach the operating wavelength. It has been explained that with the triode oscillator circuit an output at comparatively high power is available at the second harmonic, so that this leaves only a four-fold increase before the final amplifier.

It would be possible to quadruple the crystal frequency in the first stage, but the power in the fourth harmonic will be about one watt only; nevertheless, this might be sufficient to operate a doubling stage for a 10-watt final amplifier. This matter is actually being further investigated in view of the convenience it would afford in building a portable five-metre transmitter for field-day use.

The difficulty encountered in a five-metre transmitter is that owing to the comparatively low input impedance of most

valves at these high frequencies quite a lot of driving power has to be provided to operate an RF amplifier under Class "C" conditions.

For a 50-watt output stage fitted with some neutralised triode valves the writer finds it necessary to provide about eight watts to drive the valve to full output, though considerably less will suffice if the frequency is changed from 57 to 28.5 Mc/s. It will thus be seen that the power has to be kept at a high level in the frequency doubling stages in order to avoid the need for a pre-amplifier before the final stage.

It is a good plan to increase progressively the size of the valves in the transmitter so that as the frequency is raised the power in the succeeding doubler stages also increases despite the fact that the efficiency may show a falling off at the higher frequencies.

Any circuit which in theoretical form looks like an RF amplifying stage, such as that shown in Fig. 1, can be used as a frequency doubler merely by tuning the

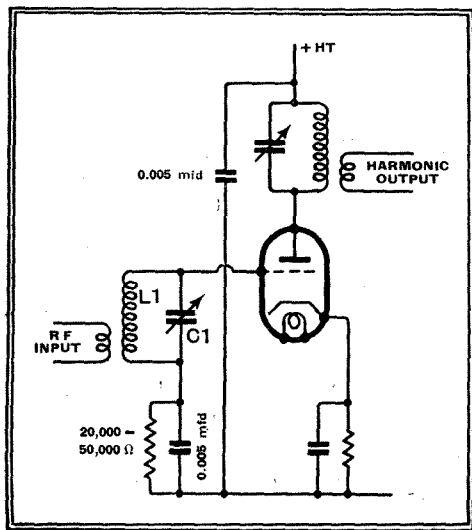

Fig. 1.—A simple frequency doubling circuit in which the anode circuit is tuned to twice the frequency of the grid circuit.

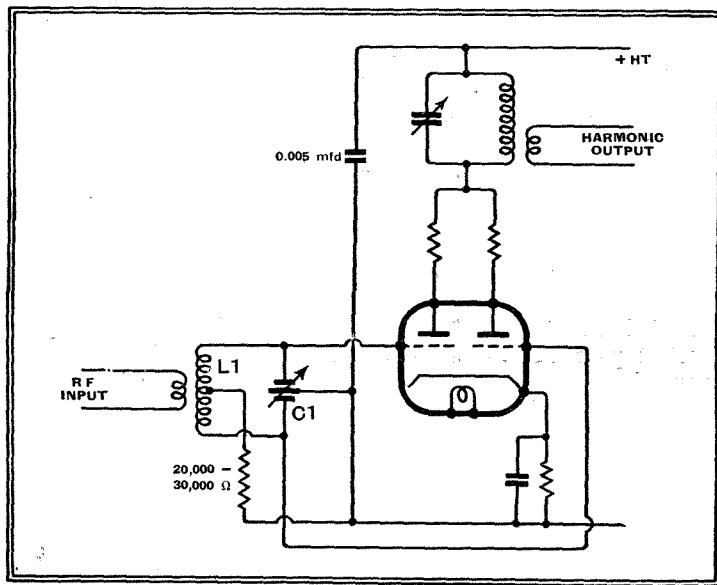

Fig. 2.—A push-pull doubler suitable for frequencies up to 28 Mc/s.

anode circuit to twice the frequency of the grid circuit and by applying sufficient input to drive the valve into grid current.

Alternatively, the grid circuit can be biased to twice or three times the "cut off" value. In either case the anode circuit should have a high L/C ratio, using only just sufficient capacity to tune to the required frequency.

Another arrangement that functions well as a frequency doubler is that shown in Fig. 2, for which either two valves, or a double triode such as the Mullard TV03-10, can be used. In the form shown it is quite satisfactory for doubling up to

Frequency Doublers—

28 Mc/s output. If, however, the anode circuit be modified and arranged as in Fig. 3, the RF output at the higher frequencies is improved, which is probably

Another precaution that should be taken is to connect anti-parasitic resistances of between 5 and 20 ohms close to each anode as shown in the circuits.

A vertical screen between the grid and anode circuits sometimes cures instability, but only when the self-oscillation is at either of the two operating frequencies; it will not cure parasitic oscillation.

A circuit which is proving very satisfactory as a frequency doubler from 28 to 56 Mc/s and which provides sufficient output to load fully a 50-watt neutralised triode operated as a Class "C" amplifier is shown in Fig. 4.

The valve used is the Tungram OS12/501 and its input which is at 28.48 Mc/s is provided by a push-push stage doubling from 14.24 Mc/s.

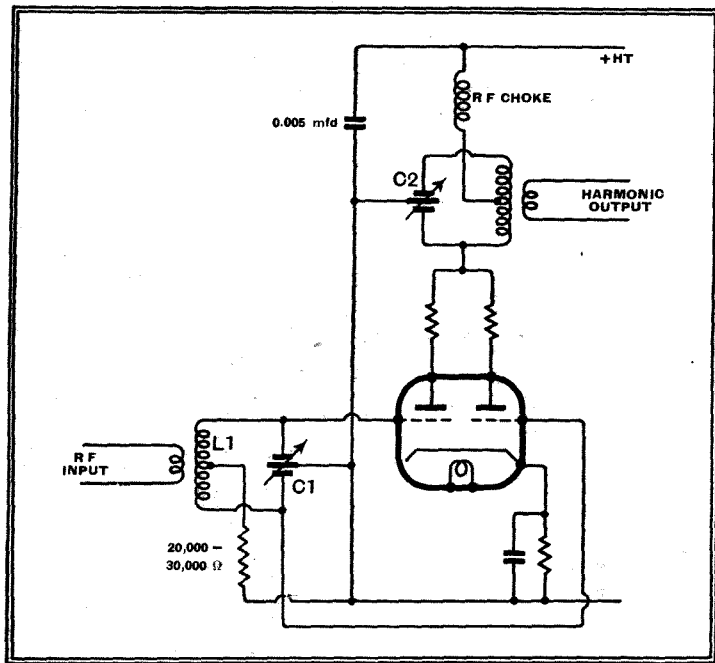

Fig. 3.—Method of modifying the circuit of Fig. 2 for operation up to the highest amateur frequencies.

due to the fact that a better impedance match is effected between the valve, the circuit and the load.

The only difference is that a split stator condenser is used in the anode circuit and HT is applied through an RF choke to the centre of the coil.

In this circuit the grids are connected in push-pull, but the anodes are in parallel. It is essential to use a split stator condenser for C1 in circuits of Figs. 2 and 3, while the condenser must be mounted so that the shortest possible connections can be made between the two grids of the valve and the fixed vanes of the condenser. The earth lead should take the shortest possible path from the moving vanes of C1 to the cathode of the valve and it must be of large diameter.

Unless these precautions are taken the stage may go into self-oscillation, but such oscillations will not necessarily be at the input or output frequencies, but at a very high parasitic frequency, dependent on the length of the leads between condensers C1 and C2 and the valve and the earthing leads of C1 and C2 in Fig. 3.

The OS12/501 is connected as an RF pentode as this was found to give the best results in the writer's case; the valve has just under 200 volts on the screen grid. The screen current is about 15 mA and the anode current is 60 mA at 350 volts, with the anode circuit loaded, while the grid is biased to -120 volts. There is also a grid resistor, R1, of 10,000 ohms to provide a little extra grid bias

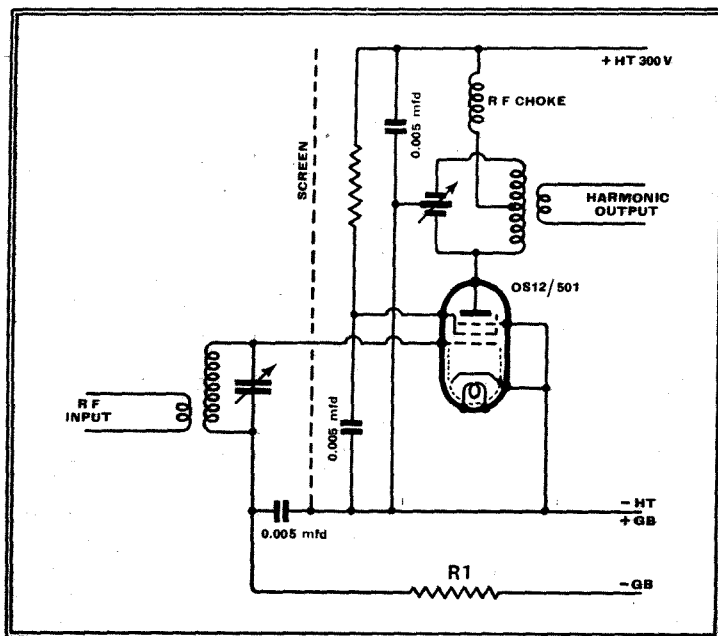

Fig. 4.—A recommended circuit for use on all the short and ultra-short amateur wavelengths.

from the rectified RF input. A very rough measurement shows that about 8 watts can be drawn from the anode circuit on 56.96 Mc/s though it may actually be

more owing to the difficulty in obtaining reliable measurements at these high frequencies.

This stage will drive a power amplifier with a comparatively low input impedance at the working frequency and give 20 mA of grid current. The grid bias for this valve is also -120 volts, while there is a grid resistor of 5,000 ohms in addition.

If this valve were used as a frequency doubler on lower frequencies, such as 7 to 14 or 14 to 28 Mc/s, lower screen and anode potentials could be used as the grid impedance of the amplifying valve would be higher and less driving power needed. This will, of course, result in a saving in HT current. No trace of instability has been encountered, though as a precautionary measure the grid and anode circuits were isolated by a vertical screen as shown in Fig. 4.

Owing to the relatively small input power needed for the OS12/501 (the makers give this as 0.3 watt; the highest frequency is not stated, but it is apparently quite high as a ceramic base is fitted), it would appear to have great possibilities as an RF power amplifier on five metres. This matter is certainly well worth investigating.

Something New in Car Aerials

THE problem of an efficient aerial for the car radio set is one that has engaged the attention of inventors ever since car radio itself first made its appearance. There can be little doubt that for efficiency, one of the best arrangements that could be employed would be a vertical rod rising from the roof, as not only would it be a better collector of signals, but it would be comparatively remote from the ignition system.

A vertical rod of the type mentioned is an obvious impracticability where cars have to pass under low archways or bridges, and, although many devices have been put forward, including rods which can be lowered manually, none has been entirely satisfactory. A new device developed in the laboratories of the Telefunken Company does, however, seem to fill the bill. It is, in effect, nothing more or less than a thick-walled rubber tube which is tapered and rather resembles a rolled umbrella, mounted vertically on the roof.

Inside this rubber tube is secured a flexible aerial wire. When any overhead obstruction is encountered, it pushes over the whole contraption to a position parallel with the roof. Immediately the obstruction is passed the rubber tube springs into its normal vertical position once more. Arrangements are made whereby the tube is fastened to the roof in an exceptionally simple manner. An insulating bush projects slightly from the roof, and the lower portion of the tube, which is completely hollowed out, is pulled over this bush in the same manner as the rubber covering on the handle of a cricket bat.

This arrangement has obviously still greater possibilities in the case of a vehicle fitted with a U.S.W. transmitter.

NEW ADDRESS

IN connection with the review on page 429 of the last issue of the Model 60 signal generator made by Taylor Electrical Instruments, Ltd., it should be noted that the new address of the company is 45, Fouberts Place, London, W.1.

Orchestral Pitch

A CATHODE-RAY METHOD OF MEASUREMENT DURING A CONCERT

FROM September 27th to December 31st, 1938, a series of about 530 observations was made regarding the tuning of musical instruments and orchestras as observed in radio programmes. For this purpose a new, sturdy, entirely AC mains-operated measuring instrument was constructed containing a string kept in vibration by electrical means whose frequency was accurately adjustable between 400 and 470 c/s. By comparison with a chronometer and a synchronous motor the relative and the absolute calibration could be carried out to a precision of 0.2 c/s.

The method of observation was as follows: A frequency band of roughly 400-470 c/s was filtered out of the incoming music voltage. (For comparison, it may be noted that for $a=440$ c/s we have a flat = 415 c/s and a sharp = 466 c/s.) The voltage allowed to pass in this frequency region was applied to the "grid" of a cathode-ray oscillograph, so that the spot was only visible when a note within this frequency band was present in the music. At the same time the alternating voltage developed by the vibrating string was applied to the deflection plates of the cathode-ray oscillograph in such a way—by a 90-degree phase shift between the two pairs—that a circle was described by the spot with an angular frequency equal to that of the measuring apparatus. A part of this circle was therefore only visible when approximately the same frequency was present in the music as that of the reference frequency.

By **BALTH. van der POL, D.Sc., and C. C. J. ADDINK**

(Natuurkundig Laboratorium, N. V. Philips' Gloeilampenfabrieken Eindhoven, Holland).

THE efforts which are being made to establish a new international standard of pitch should be materially assisted by these scientific measurements made during the course of recent broadcast performances.

When there was slight difference between these two frequencies the arc of the circle visible on the screen turned either to the left or the right at a frequency equal to the difference between the music frequency and the frequency of the measuring apparatus. The latter was then adjusted in such a way that when during the music the arc became visible it was also almost stationary. The frequency a of the music could thus be read on the dial of the measuring apparatus. In this way the frequency of the note a , originating, for

instance, from an organ stop, could be measured accurately to within ± 0.2 c/s, whilst, owing to the continuous fluctuation in the tuning, an accuracy of ± 0.5 c/s could be attained for orchestral instruments.

Analysis of the Mengelberg Concert on October 27th, 1938.—On this occasion

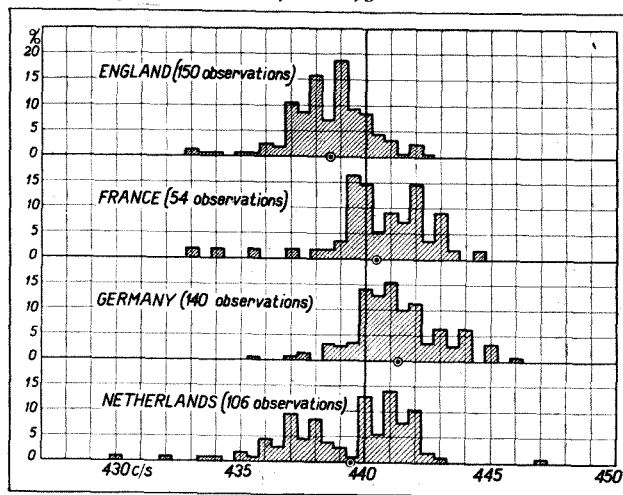

Graphs showing the "scattering" of pitch in the broadcast programmes of four countries from Sept. 27th to Dec. 31st, 1938. The vertical scale represents the percentage of occurrence of the various frequencies.

Beethoven's first piano concerto was played. During the tuning of the orchestra the predominating tuning was 441 c/s, whereas the piano was at 440 c/s; the orchestra had a tendency in the *tutti* to take the a 2 c/s higher, but it dropped 2 c/s again when the piano set in. After the interval a Brahms' symphony was played. During the tuning of the orchestra 443 c/s was noted, during the first part of the concert 444 c/s (horn) was found, whilst four minutes later 441.5 c/s was found as the mean value of all the instruments. During the second part of the symphony 442 c/s was found for the horn; afterwards a mean value of 442.5 c/s was found. The average for the string instruments in the third part of the symphony was 442.5 c/s, whilst at the climax towards the end the horns gave a predominating value of 443 c/s.

Concert given by the Municipal Orchestra, Birmingham, October 27th, 1938 (oboe concerto with orchestra—and piano—of Bach).—The tuning of the string instruments before commencement of the performance was 440 c/s; during the performance the value found for the piano was 435.5 c/s. During ensemble the orchestra dropped to the tuning of the piano. Later the orchestra, without the piano, rose to 438.5 c/s; at that moment the tuning of the oboe was 439 c/s. It was, furthermore, found that generally the wind instruments suddenly dropped about 2 c/s at the end of a long sustained note. Also, particularly, singers seem rather un-

PERMANENTLY TUNED INSTRUMENTS (pianos, organs, etc.).				
	Number of observations	Mean frequency (c/s)	Max. observed frequency (c/s)	Min. observed frequency (c/s)
England ...	75	438.0	442 (piano, Nov. 9th)	433 (concert-organ, Dec. 16th)
France ...	40	439.9	443.5 (piano, Sept. 28th)	430 (organ St. Eustache, Dec. 29th)
Germany ...	58	440.8	445 (piano, Nov. 22nd)	435.5 (harp, Dec. 7th)
Netherlands ...	53	437.9	443 (V.A.R.A. organ, Dec. 5th)	430 (organ St. Vitus' Church, Hilversum, Dec. 23rd)
ORCHESTRAS				
England ...	75	439.0	442.5 (string sextet, Dec. 27th)	434 (harp trio, Dec. 28th)
France ...	14	442.0	444.5 (orchestra, Dec. 15th)	441 (orchestra, Dec. 28th)
Germany ...	82	441.5	446 (string orchestra, Dec. 23rd)	438.5 (orchestra (amusement), Oct. 24th)
Netherlands ...	53	440.6	447 (V.A.R.A. "Kingler trio" Nov. 4th)	436 (V.A.R.A. "Fantasia," Dec. 28th)

PERMANENTLY TUNED INSTRUMENTS AND ORCHESTRAS (total for both together).

	Number of observations	Mean frequency of all observations (c/s)	Max. observed frequency (c/s)	Min. observed frequency (c/s)
England ...	150	438.5	442.5	433
France ...	54	440.4	444.5	430
Germany ...	140	441.2	446	435.5
Netherlands ...	106	439.3	447	430

Orchestral Pitch—

certain in the matter of accurate tuning.

The foregoing analyses show that the method of measurement employed has the advantage both of accuracy and rapidity of measurement; a constant tone of a duration of $\frac{1}{2}$ second generally suffices to make the frequency measurable.

In the accompanying table we give the results of measurements as regards the extreme and the average tuning observed at performances in England, France,

Germany and the Netherlands. Separate data are given for permanently tuned instruments and orchestras. The mean frequencies of all observations are: England, 438.5 c/s; France, 440.4 c/s; Germany, 441.2 c/s; and the Netherlands, 439.3 c/s.

Finally, in the series of graphs the ordinates present the percentage of occurrence of the frequencies given by the abscissæ, thus yielding a general impression of the scattering of the data.

The Montreux Plan

SOME ASPECTS OF THE NEW CONVENTION

ALTHOUGH the full text of the Wavelength Plan, which was evolved at the Convention Européenne de Radiodiffusion, Montreux, which ended on April 15th after nearly seven weeks' duration, has not yet been published by the U.I.R., *The Wireless World* is now able to give some interesting facts gleaned from the Plan.

The European Zone which is embraced by the Plan has as its borders in the north and west the normal European boundaries. In the east it is marked by the 40th meridian of longitude, and in the south by the 30th parallel of north latitude. Thus it includes part of Asia Minor and all the Mediterranean coastal countries.

It is now learned that all the participating countries signed the Convention, but the following five signed with reservations:—Luxemburg, Iceland, Turkey, the U.S.S.R. and Greece. This means that Luxemburg, which has been allocated the 218.2-metre wavelength, which it is to share with two Estonian and a Greek station, will probably continue as a pirate on the long-wave band. Iceland is discontented over the fact that she has to share 1,453 metres (206.5 kc/s) with Turkey and the U.S.S.R., and may therefore use an alternative. Turkey, too, is disgruntled over the same matter.

Although the representatives of the telegraph administrations and broadcasting organisations of the various countries have signed the Convention, it still remains for the Governments concerned to ratify the undertakings through the usual diplomatic channels to the Swiss Government.

The Convention will continue to apply to all matters relative to broadcasting in Europe until such time as a new Plan is evolved, which can be effected by ten of the contracting Governments expressing to the Swiss Government their wish for a revision.

Although it is not yet known what attitude will be adopted regarding wavelengths by the five countries who signed with reservations, it is interesting to see who, according to the Plan, will be our neighbours. Droitwich (198.5 kc/s), whose power it is proposed to raise from 150 to 200 kW, will have on the one side Deutschlandsender (189.5 kc/s), whose

power is to be raised from 60 to 200 kW, and on the other Ankara (120 kW), Reykjavik (100 kW) and Minsk (50 kW) sharing 206.5 kc/s.

As has already been pointed out the geographical position of Great Britain makes it possible for her to share wavelengths with other countries which would be impracticable for central European states. On the medium-wave band, therefore, we have only two exclusive frequencies, namely, London Regional (916 kc/s), the power of which is to be increased from 70 to 120 kW, and Midland Regional (1,087 kc/s). The channels on either side of London Regional are to be shared by Lwów (50 kW) and a projected 1-kW Spanish station and by two Germans, Graz (15 kW) and Klagenfurt (5 kW). Midland Regional has on one side Bratislava, the power of which may be raised to 120 kW, and on the other Heilsberg (120 kW), Lisbon (20 kW) and Alexandria I (5 kW). The main points about the nine non-exclusive channels allocated to Great Britain are that they are, without exception, shared with stations of lower power.

Directional Aerials

For the first time in the allocation of shared wavelengths directional aerials have been taken into consideration. In all, some thirty stations have been allocated wavelengths with the stipulation that they use aerials directed in a certain quarter or alternatively use an aerial which reduces the indirect wave in a certain direction.

The only British stations affected by the directional aerial stipulation are Start Point and the projected relay transmitter at Norwich. Start Point, of course, already has an aerial which reduces radiations to the south, and Norwich must use an aerial reducing radiations to the N.E. and S.E.

Among the stations which are to use directional aerials the following are of interest:—Toulouse P.T.T., 825 kc/s (363.6 metres), must use an aerial reducing radiations to the N.E.; the 17 kW Saarbrücken transmitter (1,321 kc/s), the power of which it is proposed to raise to

120 kW, must reduce radiations to the S.S.W.; and Radio-Normandy, which has been allocated 1,420 kc/s (211.3 metres), the Yugoslavian common wave, must reduce radiations to the E.S.E.

Certain stations have been notified that if they are informed by a coastal station that their transmissions are affecting ship-to-shore traffic they must cease transmission at once. The frequencies so classified are 260 kc/s (1,154 metres), which is shared by four Norwegian stations (Bergen I, Hemnesberget, Oslo, and Trøndelag); 355 kc/s (845 metres) Bergen II; and 518 kc/s (579 metres) shared by three Germans (Innsbruck, Nürnberg, and Salzburg) and two Norwegians (Vest-Telemark and Hamar).

Power Limitations

If the following stations wish to increase their projected day or alternatively night power they must use aerials reducing radiation in certain directions:—Madona (50 kW), Latvia; Smolensk (10 kW), U.S.S.R.; Odessa (10 kW), U.S.S.R.; Fredrikstad (1 kW), Norway, and Helsinki I (60 kW night power), Finland.

Power limitations have been imposed by the Convention. As was proposed long-wave stations will be permitted to use 500 kW by day and 200 kW at night. Medium-wave stations are divided into three categories: Between 192.3 and 200 metres, 10 kW; between 200 and 230.8 metres, 30 kW; and between 230.8 and 1,250 metres, 120 kW. Stations operating on a national common wave are limited to a power of 5 kW, whilst the aggregate power of stations working on such a wavelength must not exceed 10 kW. There are two types of international common wave, on one of these power is limited to 2 kW and on the other to 0.2 kW.

In the official Plan there are very, very many blanks in the columns showing the maximum day and night power, which apparently means that the stations will not recognise a definite maximum.

With such a gargantuan task before the Conference as that of accommodating a further 103 stations, bringing the total number to 373, in the already overcrowded medium- and long-wave bands, the general result is surprisingly satisfactory. Listeners must now "wait and see" what happens when the Plan becomes operative at one minute past midnight G.M.T. on the night of March 3rd-4th, 1940.

HENRY FARRAD'S SOLUTION

(See page 438)

ASSUMING that "the man" was correct in pronouncing the set in order, the most probable cause of inferior results lies in the fact that reception by mains aerial often depends to a considerable extent on which way round the mains plug is inserted. Mrs. Frickton would not know anything about this, and would not have paid particular attention to the matter. Henry Farrad, therefore, suggested that she try reversing the plug.

Frequency Modulation in America

ANTI-NOISE BROADCASTING UNDER TEST

NEARLY a dozen frequency modulated broadcasting transmitters with power ratings up to 50 kilowatts are at present under construction in the north-eastern states of the U.S.A. All of these employ the methods of Major Edwin H. Armstrong. The stations are owned by various organisations, but in each case the management is well experienced in broadcasting and has turned to frequency modulation only after studying the results of extensive field tests. This is accordingly not a mushroom growth. It may instead be a first step towards a re-organisation of American (and possibly European) broadcasting methods to attain advantages which justify the cost of new receivers—receivers which are deaf to most electrical noise and not susceptible to the commoner sorts of fading, but capable of reproducing with extreme fidelity all that which goes into the transmitting microphone. Your correspondent is painfully aware of a tradition that we Americans are given to bragging. Therefore, he has been at some pains in the following paragraphs to avoid any claims which have been contradicted by published matter or by statements of the various engineers interviewed, these men being chosen for the deliberate purpose of obtaining adverse views.

The Armstrong method of frequency modulation was announced about four years ago. It is based upon the concept that a radio receiver can be protected from most electrical noises if it can be made to ignore voltage changes at the grid of the first valve. Of course, the noises arrive at that grid as voltages. However, if the receiver is made deaf to voltage changes it also becomes deaf to ordinary broadcast signals, since these contain the desired sounds only in the form of changing voltages; that is, the radio-frequency energy stream (carrier), before it left the sending station, was moulded or modulated so that its voltage varies from instant to instant "in a sound-frequency manner." Since these variations are not apparent to a voltage-deaf receiver resort is had to a transmitter which sends forth *constant* carrier energy. The sounds are then imposed upon the carrier-stream in the form of variations in its *frequency*; that is, by "wobbling" instead of "moulding." The extent of the wobble represents the loudness of the sound to be conveyed, the rapidity of the wobble represents the sound pitch. Now, by giving the receiver the ability to perceive frequency changes it again becomes useful, though still deaf to voltage changes—among which reside the noises. The process is not perfect, of course, but in daily practice it approaches the ideal so closely

OUR American correspondent has been given special facilities for investigating the working of frequency modulation by Major Edwin H. Armstrong. We are also indebted to Major Armstrong for having "vetted" the manuscript of this article.

that Armstrong receivers can operate virtually noiselessly when run "wide open" for the purpose of bringing up weak signals which, with ordinary transmission and reception, would be spoiled by noise. This statement will be made more specific in a later paragraph.

Objections were instantly raised to the original Armstrong system, whose history has indeed been one of critical re-examination by Major Armstrong himself and by

BY OUR NEW YORK
CORRESPONDENT

other investigators. The matter is not simple and there are honest differences of opinion. However, much of the original doubt has been removed. The boggy of a transmitter "requiring a band width of 150 kilocycles" has turned out to be rather baseless for reasons to be explained later. Somewhat similar reasons exonerated the Armstrong receiver from the noise acceptance traditionally inherent in broad-band receivers. The so-called "prohibitive complexity" of the Armstrong receiver has been whittled down until there is a perfectly practical 6-valve type—though the 12- and 15-valve types are naturally better. However, the toughest of the traditions remained in the form of a sturdy conviction that Armstrong transmission was a short-range affair, not of

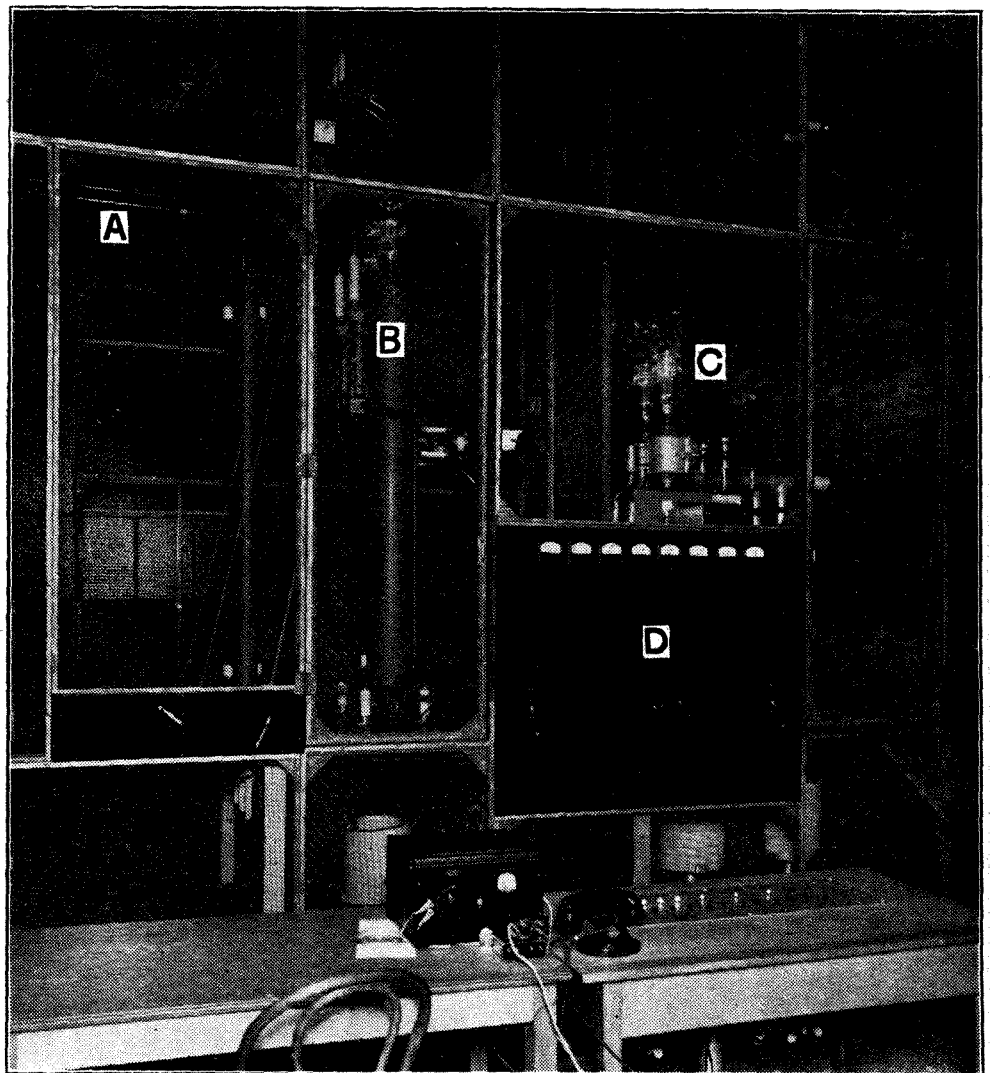

The last two stages of the W₂XMN transmitter. A, input line from earlier stage. B, push-pull driver stage. C, push-pull output stage. D, meters for the two final stages; their needles remain quite stationary during operation.

LAYOUT OF THE 40-kw FREQUENCY-MODULATED TRANSMITTER

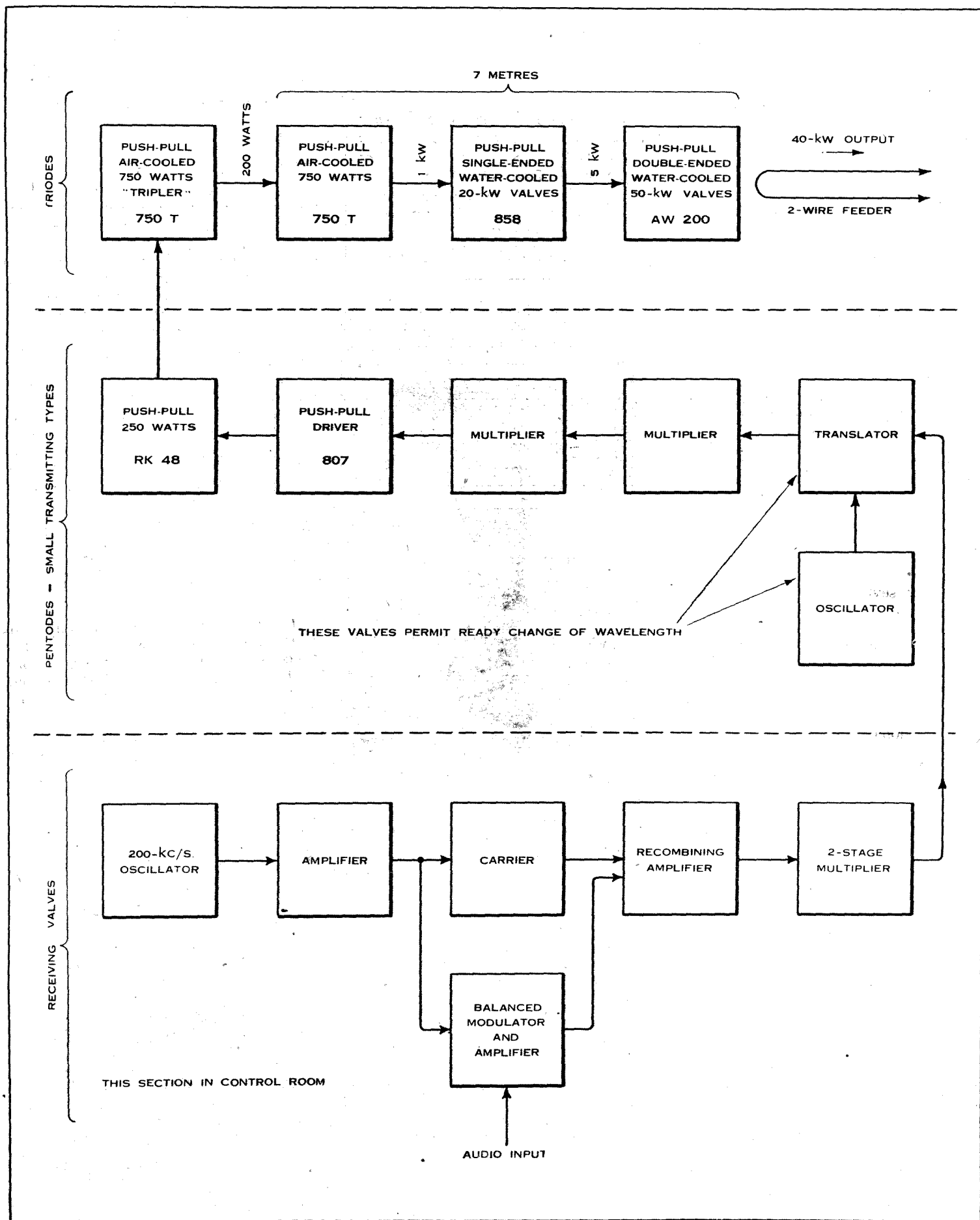

This block diagram shows the functions of the various stages of the experimental Armstrong station at Alpine, New Jersey

Frequency Modulation in America—

serious concern to a practical broadcaster—this despite the evidence in the original descriptive paper of 1935.

It became necessary to make a full-scale demonstration, and this is being done daily by the new 40-kilowatt Armstrong-modulated station W2XMN at Alpine, New Jersey, about fifteen miles from the centre (Columbus Circle) of New York City. This station, working at a wavelength of approximately 7 metres, and employing a 40-kilowatt transmitter, is being compared with several other 50-kilowatt stations, each being the head station of a broadcasting chain. They are the rather elderly WEAF of the National Broadcasting Company Red network, working into a "T" antenna at 660 kc/s; WJZ (N.B.C. Blue network) operating with a modern vertical radiator at 760 kc/s; WABC of the Columbia Broadcasting System, at 860 kc/s; and WOR of the Mutual System, with a directional array aimed along the coast at 720 kc/s. Four of these five stations have very large radial earthing systems: W2XMN has none and needs none; also it has a further advantage conferred by 40-Mc/s operation—strong concentration of radiation into the horizontal plane is possible with a reasonably compact aerial array of "turnstile" type. The power gain at Alpine without resorting to a directional system is about five times. This is accomplished by fourteen dipoles, of which seven are in a vertical north-south plane, the other seven in a vertical east-west plane. The vertical mast forming the axis of the turnstile is supported between the top two cross-arms of a 400ft. tower standing at the top of the 500ft. cliff which forms the west bank of the Hudson River. The ability to utilise such a location is peculiar to frequency modulation. Were a conventional station to be located here no ground net could be provided. Even a 7-metre station working with 40 kilowatts might be impractical, if modulated in the usual manner, because of the overloading of nearby receivers. With the Armstrong system, however, receiver overload is hardly a problem. The transmitter of W2XMN is exceptionally simple in appearance. As shown by the block diagram most of the stages are quite small. The tuned circuits of the two watercooled stages are of the tubular variety, hence less formidable than the usual coil-and-condenser combinations.

Technical Features

Most striking of all, every meter stands quite still; there are no amplitude variations. This permits running all the valves (except a few cheap receiving tubes) in pure Class "C" telegraph fashion, materially raising the efficiency, which approaches 50 per cent., even for the large final-stage tubes. Offhand, one is surprised that no broadening resistors appear on the tuned circuits—it is hard to escape the "great band width" idea—but after all the band width is well under half of 1 per cent. of the carrier. The station goes

on the air with less than the normal hang-fire, and there is, of course, complete absence of the usual complaints from the power supply system since all the magnetic cores carry steady loads. The only disturbance is due to the air blasts cooling the glass seals of the final stage.

The line-of-sight range of the W2XMN



The small aerial can just be seen between the upper arms of the tower of the Armstrong station at Alpine.

antenna is about 35 miles, hence the main interest is in effects beyond that distance. At Bridgeport, Connecticut, 45 miles distant, the measured field-strength varies from 100 microvolts per metre upward. The 100-microvolt location is at the plant of the General Electric Company, where electrical shop noise is severe; moreover, a nearby steep hill is constantly being climbed by buses and trucks. Although the W2XMN signal here is 1/20th of the strength considered necessary in a quiet residential district for conventional modulation, virtually no noise has ever been heard on W2XMN except during two brief fades. No selective fading has been perceived. Several of the 50-kW stations cited before suffer from severe selective fading; all are subject to noise and interference, while ordinary fading is common.

Through the courtesy of Major Armstrong your correspondent spent an evening at Sayville, L.I., 50 miles from W2XMN and about the same distance from W2XCR, the 600-watt, 110-Mc/s

Armstrong-system station of C. R. Runyon. The field of W2XCR has not been measured, but it is improbable that the signal at Sayville is ever as strong as 20 microvolts per metre—that is to say, 1/25th the value regarded as suitable for good reception with conventional modulation in quiet rural locations. On the evening of the test, conditions were such that a signal of 500 microvolts would have been utterly useless. Using an up-to-date high-fidelity receiver, it was possible to make very little use of the 50-kW signal of WABC at 55 miles, and then only by severe use of the tone control. Selective fading of WABC was bad. Even the 50-kW WEAF at 24 miles was frequently blotted out by crashes. Switching to the 42-Mc/s signal of W2XMN instantly and completely blotted out the atmospherics, though the signal field-strength was perhaps 90 per cent. less. Moreover, the fidelity of reproduction was very much better. Switching to the 110-Mc/s, 600-watt signal of W2XCR accentuated the contrast, for the atmospherics were still completely absent and there was no sign of fading. When the station was not modulating, it was possible to find a "background" at maximum receiver sensitivity, though this was not the usual uproar, but a light sound as of a very small steam leak. This is characteristic. Motor cars passing the house produced a mild patter, audible only if there were no speech, and then only for a few seconds.

Long-range Reception

The potentialities of the transmitter at W2XMN is by no means exhausted at distances of 50 miles. At East River, Connecticut (85 miles), the carrier is strong, and very fair speech has been derived from it with makeshift receivers unsuited to the job. At points near Philadelphia (about 100 miles) the W2XMN signal has, by the testimony of numerous observers, been consistently fadeless and noiseless, although WOR and WABC (both nearer) are at times severely affected. At Schenectady, N.Y., roughly 120 miles from the station, much listening has been done by employees of the General Electric Company. Very good results are usually obtained despite the intervention of the numerous spurs of the Catskill Mountains.

American Broadcasting Stations Using Armstrong Modulation Now in Operation or Under Construction

STATION	OWNER	AERIAL POWER
Alpine, N.J.	E. H. Armstrong	20-40 kW.
Washington D.C.	Jansky and Bailey	1 kW.
Mount Washington, N.H.	Yankee Network	2 kW.
New York, N.Y.	J. V. L. Hogan	1 kW.
Storrs, Conn.	D. A. Noble	100 watts
Rochester, N.Y.	Stromberg-Carlson*	2 kW.
Meriden, Conn.	Doolittle Radio Corp.	1 kW.
Schenectady, N.Y.	General Electric	10 kW.
Pittsburgh, Pa.	Westinghouse	10 kW.
Springfield, Mass.		1 kW.
Worcester, Mass.	Yankee Network	50 kW.
Yonkers, N.Y.	C. R. Runyon	600 watts

* Licence applied for.

It thus appears that W2XMN has a service area which is at least comparable to the best of our present conventional stations, even when conditions are favourable.

Frequency Modulation in America—

Under adverse conditions W2XMN is superior.

It is difficult to comment on fidelity of transmission when the basis is simple listening and the same speaker is not used on both signals. However, it is fair enough to say that the Armstrong receiver and its speaker gave forth a product I have not heard equalled by any other radio receiver.

This is by no means due solely to the use of high-quality audio circuits, though it is quite true that these are "flat" to 16,000 cycles (sender, receiver, and loud speaker). Normally, such systems are useful only at very short ranges or under exceptionally favourable conditions. But here was quite another matter—a half-kilowatt station 50 miles away, an evening so noisy as to ruin conventional reception, yet in the living-room at Sayville there was undisturbed *silence* when the microphone at Yonkers was cut off. There were no valve noises, there was nothing at all but the patter of rain on the window. It was astonishing. Nor did listening with the ear to the loud-speaker grille disclose much more. It was by long odds the quietest radio circuit your correspondent has listened to, despite its broad response.

Realistic Reproduction

The perennially difficult piano, the sound of pouring from a bottle into a glass, the tearing of paper, all were reproduced extremely well. The lighting of a safety match "came through" surprisingly well. Finally, the circuit was made two-way by

telephoning to Yonkers—we speaking by wire, and Mr. Runyon by radio. The illusion that Mr. Runyon was in the room was very strong.

It may be argued that interference is eliminated principally by the use of 7 metres, not by the method of modulation. This is partially correct, but 7-metre interference is an actuality, and 7-metre motor car interference is extremely real. There is also fluctuation noise, which in some conventional 7-metre receivers is very bad, its source being principally the thermal agitation in the first coil of the set. (At shorter wavelengths the gain of the first valve is poor, and the shot noise in its anode circuit may rise above the input coil noise.) In any method of transmission a sufficiently strong carrier will swamp noise—any special merit must hinge on ability to do this with a weak carrier. In some measurements made by the General Electric Company, and reported to an informal gathering at Columbia University on March 22nd by G. W. Fyler and J. A. Worcester, it was found that for one particular receiver tested on a signal generator which could be modulated by either method the threshold of improvement of the signal/noise ratio (for fluctuation or receiver noise) was reached with a weaker carrier when frequency modulated. For any particular carrier strength the signal/noise ratio was more favourable by 20 to 25 db. when using Armstrong modulation. This is an inherent advantage, but its magnitude depends among other things upon the width of the frequency swing and also upon the type of noise encountered.

(To be concluded.)

- 9 Trimmers, 30-60 mmfds. **Bulgin SW122**
- 1 Trimmer, 3,000 mmfds. **Bulgin CP7**
- 1 Double Trimmer, 150-550 mmfds. **Polar 55**
- 1 Set of Coils, PA1, PA2, PA3, PHF1, PHF2, PHF3, PO1, PO2, PO3 **Wearite**
- Fixed Condensers:**
 - 1 0.0001 mfd., mica **T.C.C. "M"**
 - 1 0.0002 mfd., mica **T.C.C. "M"**
 - 2 0.0003 mfd., mica **T.C.C. "M"**
 - 1 0.0005 mfd., mica **T.C.C. "M"**
 - 1 0.001 mfd., mica **T.C.C. "M"**
 - 1 0.002 mfd., mica **T.C.C. "M"**
 - 2 0.01 mfd., mica **T.C.C. "M"**
 - 1 0.05 mfd., tubular **T.C.C. 341**
 - *18 0.1 mfd., tubular **T.C.C. 341**
- Resistances:**
 - 3 300 ohms, $\frac{1}{2}$ watt **Dubilier F $\frac{1}{2}$**
 - 6 500 ohms, $\frac{1}{2}$ watt **Dubilier F $\frac{1}{2}$**
 - 1 10,000 ohms, $\frac{1}{2}$ watt **Dubilier F $\frac{1}{2}$**
 - 2 50,000 ohms, $\frac{1}{2}$ watt **Dubilier F $\frac{1}{2}$**
 - 1 75,000 ohms, $\frac{1}{2}$ watt **Dubilier F $\frac{1}{2}$**
 - 1 100,000 ohms, $\frac{1}{2}$ watt **Dubilier F $\frac{1}{2}$**
 - 2 1 megohm, $\frac{1}{2}$ watt **Dubilier F $\frac{1}{2}$**
 - 1 9,000 ohms, 3 watts **Dubilier F3**
 - 1 10,000 ohms, 2 watts **Dubilier F2**
- *1 Volume Control, 0.25 megohm, tapered **Reliance "SG"**
- 4 Valve holders, octal type **Clix X218**
- 1 IF transformer, variable selectivity, 465 kc/s **Varley BP124**
- 1 IF transformer, 465 kc/s **Varley BP124**
- 6 Terminals, ebonite shrouded, A, E, PU (2) **Belling-Lee "B"**
- Output (2) **Bryce 5C2**
- 1 Connector, 4-way **Goltone R36/4MR**
- 1 Cable, 4-way **Bulgin S92**
- 1 Switch, rotary type, SPDT **Bulgin S114**
- 1 Switch, rotary type, DPDT **Peto-Scott 632FE**
- 1 Switch assembly comprising:
 - 3 switches, 3-way, SP **Peto-Scott 632FE**
 - 3 switches, 3-way, SP with earthing plates, locator and 8-inch rod
- 1 Length screened sleeving **Goltone**
- 3 Valve screens, octal type **Peto-Scott**
- 1 Shaft coupler, $\frac{1}{4}$ -inch **Bulgin 2005**
- 3 Grid clips, octal type **Bulgin P96**
- Tuner Chassis **Peto-Scott**
- Receiver Chassis, with brackets **Peto-Scott**
- Miscellaneous: **Peto-Scott**
 - 8 lengths systoflex, 3 ozs. No. 20 tinned copper wire. Screws: 5 doz. 6BA $\frac{1}{4}$ in. r/hd., 2 doz. 4BA $\frac{3}{8}$ in. r/hd., all with nuts and washers; 1 doz. extra 4BA nuts for mounting switches.

In Next Week's Issue**THE WIRELESS WORLD****DC Mains Super****A Three-band Receiver for DC Operation**

DESIGNED especially for use with *The Wireless World* DC Quality Amplifier, this new receiver is a superheterodyne covering the important wavelengths in the bands of approximately 16-45 metres, 200-550 metres, and 1,000-2,000 metres. One RF and one IF amplifier are used with a triode-hexode frequency-changer, and a diode detector and AVC source. No AF amplifier is provided here, since the detector output is intended to feed into the DC Quality Amplifier.

There are two signal-frequency tuned circuits to afford good second-channel rejection, and the RF stage ensures a good signal-noise ratio. In the interests of quality of reproduction a simple form of variable selectivity is provided.

Tested with the amplifier the receiver gave outstandingly good quality of reproduction, and yet possessed adequate sensi-

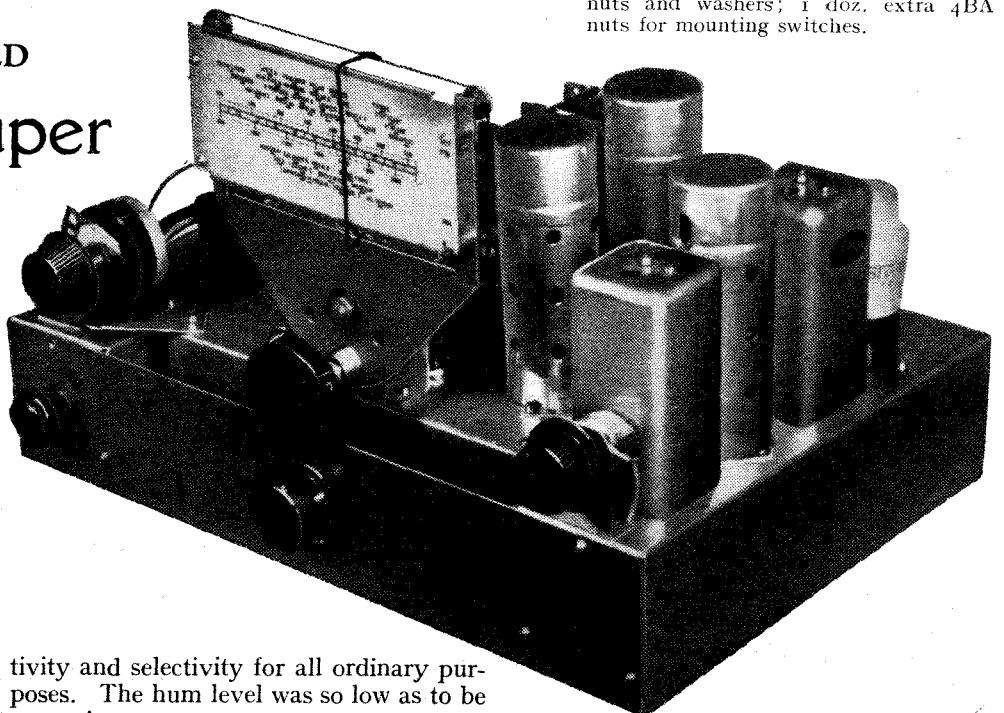

tivity and selectivity for all ordinary purposes. The hum level was so low as to be non-existent.

LIST OF PARTS

- 1 Condenser, 3-gang, 0.0005 mfd. **Polar C1703**
- 1 Dial, ratios 10:1 and 50:1 **Polar "Micro Horizontal Drive"**

Valves:

- 2 KTW63, 1 X65, 1 D63 **Osram**

*Two 0.1 mfd. condensers and the volume control can be transferred to the receiver from the DC Quality Amplifier.

NEWS OF THE WEEK

HOT-AIR GENERATORS

Power Supply for Battery Sets

A RECENT German development is the introduction of three types of hot-air generators which provide sufficient power for operating battery receivers using two-volt valves. These generators run off a simple petrol or methylated spirit lamp using one litre of petrol

Philips 338B battery superhet or similar receiver and is priced at approximately £17, although under German export arrangements the price would be considerably less. The medium-sized model supplies six watts, whilst the largest, priced at Rm.360 (approx. £30) gives

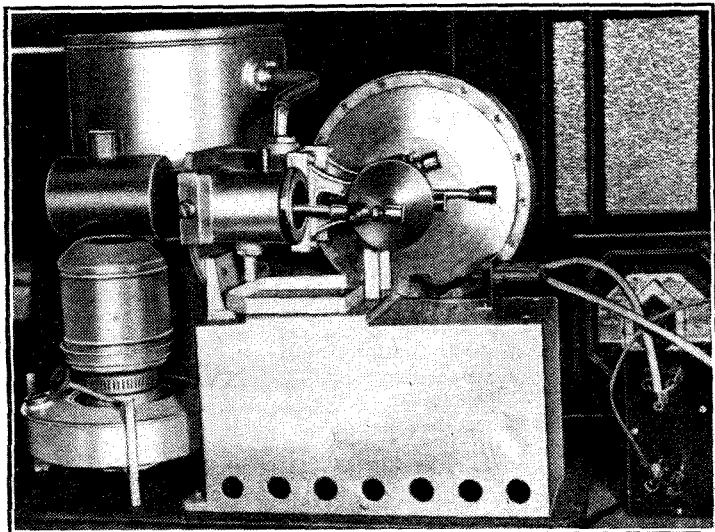

THE HOT-AIR MOTOR, showing the burner, which has been manufactured in Germany by P. Heinrici, for operating battery receivers.

for a period of ten hours' continuous working or one litre of methylated spirits for nine hours' working. A burner for charcoal or peat is also obtainable, so that the generator could be used where petrol or methylated spirit is unobtainable.

The smallest model provides just sufficient current for a

12 watts, which is sufficient for charging a six-volt accumulator such as that required to operate a receiver using a vibratory converter.

In the case of the two smaller models, two-volt accumulators are required for the filament supply of the receiver, and they are connected for trickle charging by the generator.

U.S. ARMY MANŒUVRES

Directed Through Networks of the N.B.C.

THE General Staff of the United States Army, headed by General Malin Craig, conducted a remarkable broadcast from the National Broadcasting Company's Radio City studios during the early part of the month.

Through the use of more than a hundred thousand miles of wireless networks the manœuvres of army units in all parts of the U.S.A. were directed from the temporary headquarters in the New York studio. Replies to the broadcast orders were heard from 73 microphone positions, which included those in Hawaii, Alaska and Panama.

The Programme served to de-

monstrate the remarkable potentialities of wireless in war-time.

CONCERT PITCH

Debate on International Standard

AS a result of extended deliberation under the sponsorship of the British Standards Institution, British interests have united in sending the following resolution to the Secretariat of the International Standards Association:

"That the International Standard of Musical Pitch shall be based on an absolute frequency of 440 c/s for the note A in the treble clef."

Other countries have also made their proposals, and a meeting of the I.S.A. Concert Pitch Committee with representatives of some ten different nations is being held at Broadcasting House, London, to-day and to-morrow. It is confidently expected that an International agreement of the figure to be adopted will be arrived at.

An article on the exact measurement of musical pitch appears elsewhere in this issue.

TWENTY-FIFTH ANNIVERSARY

THE American Radio Relay League is celebrating its twenty-fifth anniversary this month. The League was formed in 1914, when communication by radio was carried on by means of roaring spark transmitters, which had a distance range by direct sound almost as great as the radio oscillations produced. Hiram Percy Maxim and Clarence D. Tuska inaugurated the movement as a means of keeping all amateurs in touch with one another, and by relaying communications from station to station to overcome the handicap of short range. From 237 members in September, 1914, the League has progressed to its present position, when it represents 51,000 amateurs in the United States and possessions.

WHAT VIEWERS THINK

Results of First Television Questionnaire

THE B.B.C. has made a preliminary analysis of the results of the television questionnaire, to which over 4,000 viewers sent in completed forms.

The results are encouraging, for they show that a large majority think that the programmes provided are satisfactory and improving and that the present balance of programme material is well in line with viewers' preference.

Plays and variety programmes direct from theatres, news reels, "Picture Page" and light entertainment are popular with at least 90 per cent. of viewers. Outside broadcasts come next, followed by full length plays, cartoon films and talks.

More than half the answers affirmed that the present length of the evening programme (1½ to 2 hours) was sufficient, although they would like it to begin earlier.

It was found that 91 per cent. of the forms had come from those who owned television sets for entertainment only and not for business, and it appears that the average number of people who watch television fairly regularly on each set is four.

TRAIN TRANSMITTER

Relays by Sixteen Stations En Route

A UNIQUE series of broadcasts is being carried out from the Union Pacific Exhibition train, as it makes its way from Los Angeles to Kansas City.

The train has been equipped by General Electric with a 50-watt transmitter which works on a wavelength of about 150 metres, using the call sign



THE GENERAL STAFF of the American Army is seen conducting a public demonstration which was broadcast through 107 N.B.C. stations. General Malin Craig, Chief of Staff, is seen conversing with Mr. David Sarnoff, President of the R.C.A. and Colonel, U.S.A. Signal Corps Reserve.

News of the Week—

WOEG. Relays are being undertaken by sixteen medium-wave stations in cities through which the train is passing.

WOEG has a range of approximately twenty miles, and since the 80-year-old locomotive can pull the train at only 35 miles an hour, relays of nearly half an hour are possible as big cities are approached.

The 200-ft. transmitting aerial has been strung along three of the coaches, projecting 2ft. above their roofs.

ANOTHER MOUNTAIN
TELEVISION STATION

GERMANY'S second mountain-top television station, on the summit of the Feldberg, 2,720ft. above sea level, is now complete. It is situated roughly 20 miles north-west of Frankfurt, and will provide the large industrial populations of such towns as Frankfurt, Coblenz, Hanau and Offenbach with television.

The transmitter and also the aerial are housed in a wooden tower, as is the case at the

H.M.V.'s NEW LONDON
SHOWROOMS

SHORTLY before midday on Monday, Sir Thomas Beecham pressed a switch in a portable control box and the new showrooms of His Master's Voice, at 363, Oxford Street, were formally declared open with a flood of music from loud speakers all over the building. It may be remembered that the previous showrooms on this site were destroyed by fire eighteen months ago, but the magnificence of the new building more than compensates for the memory of that unhappy incident.

More than 50,000 yards of cable were used in the equipment of the new premises, and 210 sound and television receivers in the numerous listening rooms, and in the first floor showroom, could be demonstrated simultaneously. Sixty television receivers can be fed from the tilted wire aerials which are about thirty feet long and composed of a number of short lengths of wire inclined to the roof at an angle of sixty degrees.

The personal recording studio, in charge of Mr. E. G. Huntley, enables the public to make their own records in identical surroundings to those in which commercial recordings are made. The cost of this service ranges from 10s. 6d. a session. The innovation should be useful to artistes, but the showrooms as a whole with their display of wireless receivers, television receivers and household appliances, as well as the large service department in the basement, should be of value not only to the public, but to the prestige of the wireless industry.

CO-ORDINATING THE
GERMAN INDUSTRY

AN order has been issued by Field Marshal Göring placing the entire German electrical and radio industries under the command of the Inspector for the Communications of the Armed Forces.

The work of the two industries and particularly that of the radio industry, is to be co-ordinated under the new head so that urgent requirements of the armed forces can be met. Furthermore, arrangements will be made whereby additional demands in an emergency arising out of sudden developments in the political or commercial situation will not overwhelm the industry.

As the whole field of electro-technics is still in the stages of development, it is understood that the authorities intend to leave the industry a certain amount of freedom to maintain its progress, but the demands of rationalisation will have to be met.



RECEPTION AT 100 MILES. This illustration shows an untouched image of the Alexandra Palace television transmission received at the Isle of Wight.

IN THE FAR EAST

Broadcasting in Manchukuo

DURING the past six years, broadcasting in Manchukuo, which is operated by the State Telephone and Telegraph Company, which also controls the entire news agency system, has undergone extensive developments. In 1933 there were only three small stations and barely 8,000 licensed listeners (0.04 per cent. of the population). There are now ten stations with a total power of 125 kW and approximately 100,000 listeners. Three of the stations are in Dairen, five in Hsinking, and one each in Mukden and Harbin. The station Hsinking II has a power of 100 kW.

The number of languages spoken makes broadcasting, as in India, extremely difficult, for the population consists of five main groups, Japanese, Koreans, Manchurians, Chinese, and Mongols, and fourteen announcers are now employed for the five-language service. The work of the broadcasting organisation is strenuous, for broadcasting fulfils the function of an elementary school for the largely illiterate population.

Close connection is maintained with the advanced broadcasting system of Japan, and sponsored programmes in favour of Japanese goods are permitted.

Brocken, the reason for the latter being to prevent the formation of ice on the dipoles with the resultant impairing of efficiency. Three houses with four flats in each have been built in Königstein, a small town at the foot of the mountain just ten miles from Frankfurt, to accommodate the staff for which there is no room in the tower.

When the cables connecting the station to the studios in Amerika House, Berlin, are completed, the station will begin operation. Public television booths will then be opened in towns within the service area, and eventually receivers will be put on the market.

OLYMPIC GAMES RELAYS

THE Olympic Broadcasts Committee of Finland is busy making preparations for a large number of running commentaries on the games to be held next year, and a special Radio Bureau has been formed. It has so far been decided to commence with the erection and wiring of fifty-two microphone booths for foreign commentators. Orders are being placed for new O.B. vans and sound-on-film recording equipment. The latter is especially important as the number of long-distance telephone lines for relaying purposes is limited.

FROM ALL
QUARTERSRemotely Controlled Television
Cameras

An interesting refinement of the N.B.C.'s mobile television unit, which is closely similar to the two units employed by the B.B.C., is a remote-control circuit for focusing the cameras from the producer's panel in the mobile control room.

Forest Fires

It is understood that an experimental transmitter is to be erected by the Forestry Commissioners on one of the highest points of the 2,850ft. Moel Siabod mountain, which overlooks Bettws-y-Coed, the Caernarvonshire beauty spot, in an endeavour to deal more speedily with forest fires. The watchman, who will be able to see about 100 miles on a clear day, will transmit a warning message which will be picked up at various centres equipped with fire-fighting appliances.

Radio Tirana

FOLLOWING the complete reconstruction of Radio Tirana, the station will take its place in the regular programme arrangements of other Italian stations.

Foreign Listening in Germany

REPORTING on market investigation, one of the German specialist papers states that the marked increase in the radio industry during recent months is due to the interest in listening to the news of home and foreign stations.

Eskimo Operators

RADIO-COMMUNICATION facilities in Greenland have expanded considerably during the past year. At the moment the country possesses twenty-three radio stations which handled 17,000 messages during 1938. The first batch of four native operators qualified for their licences recently and four other Eskimos are taking the radio course which was opened by the Danish Colonial Office at the beginning of the year.

Ultra-Low Power

A DANISH short-wave amateur, OZ-DR-479, has constructed a portable 1.2-watt, 112-Mc/s transmitter-receiver from which R6-S9 reports have been obtained over a distance of nearly 20 miles.

R.S.G.B. Trophy

To Mr. H. F. Wareing, W9NY, of Milwaukee, U.S.A., goes the R.S.G.B.'s International Five-metre Trophy for 1938. Mr. Wareing succeeded in making forty-two contacts with stations more than 200 miles away.

Fifty Million Dollars for Nothing!

THE advantages of licence-free reception is being stressed by the American broadcasting organisations in current publicity material. Newspapers are invited to "splash" the following: "Read the radio log in your newspaper—fifty million dollars' worth of radio entertainment—free. That's American radio!"

New Tone-Control Circuit

OBTAINING BASS AND TREBLE LIFT

By J. E. VARRALL

THE most common tone-control circuits are the "top-cut" condenser filter and the "bass-cut" series condenser filter. These circuits are simple and effective, and today most sets are fitted with a resistance condenser shunt across some coupling circuit to give top-cut. Few sets, however, have the facility for top and bass boost, and in a high-fidelity receiver this is a very desirable feature. Top boost is useful to correct for sideband cutting in the RF amplifier, and bass boost to correct the deficiency in bass in gramophone records. It is also useful for correcting "scale distortion" when listening at a sound intensity below that experienced by a listener at the scene of the relay (for this, a tone-compensated volume control is a useful adjunct).

Boost circuits may be divided into resonant and non-resonant types. A resonant circuit, tuned to the frequency

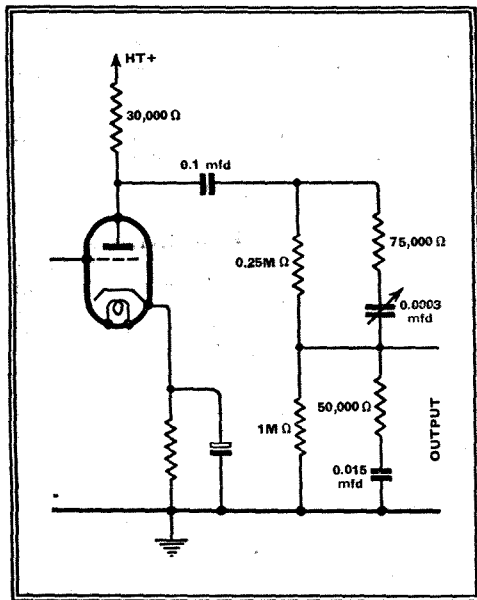

Fig. 1.—This diagram shows a normal tone-control circuit using condensers only.

at which maximum lift is required, may be made to increase the response considerably (20 db is a common figure) by virtue of its high impedance at resonance.

It suffers from the disadvantage of liability to shock excitation by transients, which may set up damped oscillations at the natural frequency of the circuit. Non-resonant circuits are less common, and suffer from the disadvantage of a very limited amount of gain. A gain of 10 db is obtainable with such a circuit in a range of about 4 octaves, i.e., the response at 50 c/s can be made about 10 db above that at 800 c/s. Such a circuit is shown in Fig. 1. Against the disadvantage of limited gain must be offset the advantages of its non-

A SIMPLE tone-control system, which enables both bass and treble response to be increased, is described in this article. Since coils are not used the possibility of hum pick-up is largely eliminated.

Fig. 2.—When two voltages in opposite phase are applied as shown here the output V_3 depends on Z_1 and Z_2 and can be made zero.

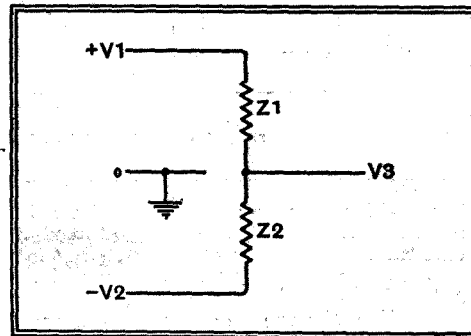

resonant nature, simplicity and absence of inductances, with their liability to pick-up hum. The limited gain of this circuit may be overcome by applying correction to two or more successive stages, but a simpler and more flexible arrangement has been used with success by the author.

Two impedances, Z_1 and Z_2 , are placed across a source of supply, the two ends of which are in opposite phase (Fig. 2). If Z_1 and Z_2 are made of the same phase angle, and $\frac{Z_1}{Z_2} = \frac{V_1}{V_2}$, V_3 will be zero, i.e., a nodal point will appear at the junction of Z_1 and Z_2 . Further, if Z_1 is made to decrease with increasing frequency, and Z_2 to increase with decreasing frequency, the balance will be destroyed, and a finite value of V_3 will be obtained for high and low frequencies. This condition is fulfilled by the simple filter of Fig. 3, the opposite phase supply being obtained from a wire-wound potentiometer in the cathode lead.

The Practical Circuit

With the slider of the cathode potentiometer at the live end it may be possible to obtain a voltage node at the output lead, at the frequency at which $\frac{Z_1}{Z_2}$ is a maximum. The degree of suppression at this frequency will be governed by the accuracy of balance of impedances; since nearly perfect balance is obtainable, very large response variation over the frequency band is possible. The range over which suppression is effective will be dependent on the values of C_1 and C_2 . If C_1 is made small and C_2 large, the entire mid-frequency band will be attenuated, and a lift obtained at each end. If C_2 is

made smaller, and C_1 larger, the response begins to increase while still in the mid-frequency band due to the variation of Z_1 and Z_2 for medium frequencies.

If very large attenuations are required the circuit becomes critical in adjustment. Large attenuation is not usually needed in normal tone-control circuits, however, and response variations of over 20 db are obtainable without critical adjustment.

The response curve for a stage using a normal medium impedance triode with a nominal stage gain of 20 is given in Fig. 4. The triode should not be of more than 10,000 Ω AC resistance or the varying impedance of the tone-control circuit will alter the voltage fed to the network. Curves A_1, A_2, A_3, A_4 are for $C = 0.0003$ mfd., $C_2 = 0.015$ mfd., $R_1 = 75,000 \Omega$, and for different settings of the cathode potentiometer. Reference to these curves shows that if the cathode potentiometer is used as a volume control a decrease in middle band response of about 15 db results in a negligible decrease at 50 c/s and a decrease of about 5 db at 10,000 c/s. This

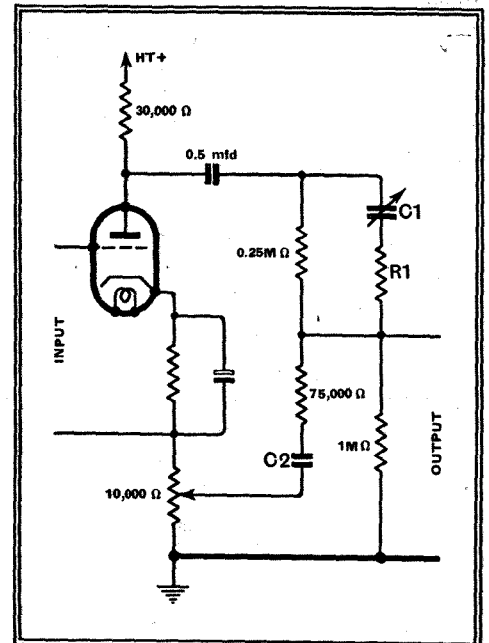

Fig. 3.—The new tone-control circuit; the response is varied by the cathode potentiometer.

compares favourably with the curves for ear sensitivity at different intensity levels. The cathode potentiometer can therefore be used as a tone-compensated control.

New Tone Control Circuit—

Curve B is obtained by short-circuiting R_1 and curve C by changing C_2 to 0.01 mfd. (the increased attenuation shows the importance of correct phase balance at the frequency of minimum gain).

This circuit, using as C_1 a variable 0.0005 mfd. condenser, and as C_2 condensers of 0.01, 0.015, 0.03, 0.05 and 0.5 mfd., selected by a switch, and as R_1 75,000 Ω , has been found very satisfactory, and capable of giving a large number of different response curves.

It should be pointed out that as it is upon the gain over the middle register that the apparent volume depends, a simultaneous adjustment of the ordinary volume control and the cathode potentiometer of Fig. 3 is necessary if a change in response is needed without any alteration in volume. As it appears in Fig. 3,

the cathode potentiometer varies apparent volume as well as changing the response.

It should not be overlooked, also, that neither of the input terminals is earthy. Consequently, the preceding coil must be a floating pick-up or diode detector, or a transformer coupling. The input can be applied between grid and earth, of

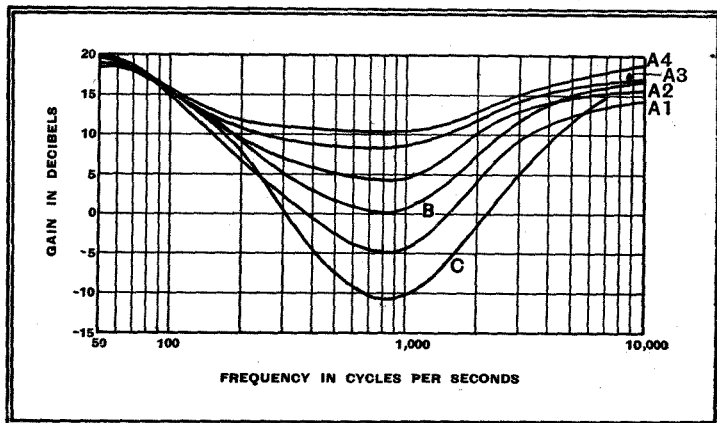

Fig. 4.—The response curves obtained are shown here. A_1 to A_4 are for $C_1 = 0.0003 \mu F$, $C_2 = 0.015 \mu F$ and $R_1 = 75,000$ ohms with different settings of the cathode potentiometer. Curves B and C are respectively with $R_1 = 0$ and $C_2 = 0.01 \mu F$.

course, but there is then a big drop in gain because of the negative feed-back on the cathode-resistance.

the low volume required from the set for these results, and I am convinced that on speech most people set the volume control far too high.

The correct setting of the volume control is rather critical, but is easier to find on speech than music. If all high-quality studio transmissions could be made at the required intensity, one could set the volume control for natural speech and leave it there for music, instead of having to fiddle about with the control repeatedly during an evening's listening.

G. A. BRIGGS,

Wharfedale Wireless Works.

Brighouse, Yorks.

Designing a School Receiver

I AM planning a school wireless set which must satisfy the following requirements:—

1. It must be so arranged that the progress of the signal through the set can be readily followed, stage by stage.

2. It must be such that boys of the VI form can assemble it.

3. It must produce good signals and be something a non-scientific headmaster can show with pride to visitors as "made by our enthusiasts of the VI form."

I should appreciate the comments of your readers on the following proposed way of meeting the above requirements:—

(a) The set should be arranged on a board or set of boards, each unit being glass-covered to keep out the dust.

(b) The circuit should be Colebrook's RF, detector and tone correction stage (one board), followed by your resistance capacity amplifier (another board). This second part to be used for playing records.

(c) The inductances should be wound by the boys.

(d) All joints should be soldered.

(e) All valves should be 4-volt indirectly heated.

(f) Heater current to come from large-capacity accumulators. (No difficulty on this point here.)

(g) High-tension supply from accumulators also.

(h) Output to be about 12 watts.

Items (f) and (g) cut out all complications of rectifiers and their smoothing circuits. Later on a rectifier unit and smoothing circuit could be made as a separate unit and demonstrated on the set.

Your readers' comments on these suggestions would be appreciated by

"ASSISTANT MASTER."

Henry Hall in Germany

REGARDING the letters that are appearing in *The Wireless World* on foreign relays and quality, I am afraid that I, for one, cannot totally agree with the views expressed by the writers of these letters.

It must not be forgotten that the performance of Henry Hall's Band for the German transmission was from a music hall and not from a studio, and it is evident that the acoustics of the building favoured the transmission very considerably. This transmission was not so well balanced as it might have been as it exhibited a preponderance of brilliancy with a lack of body, necessitating correction for this excessive brilliancy.

When "Quality Lover" turns to his explanation of the inferior quality of the B.B.C. transmissions, I am of the opinion that they are not guilty of using "carbon microphone technique" for musical transmissions. I find that the difference in the

Letters to the Editor

The Editor does not necessarily endorse the opinions of his correspondents

Secondary Emission

AFTER reading the interesting article by "Cathode Ray" on secondary emission, it occurred to me that my fellow-readers would be interested to hear of another branch of electronics where the release of secondary electrons proves most interesting (and, incidentally, troublesome). I refer to the design of X-ray tubes to operate at pressures ranging from 60 to 100 kilovolts for diagnostic work, and up to much higher pressures for treatment work. It will be at once seen that these relatively high operating voltages produce correspondingly high electron velocities; so high, in fact, that the velocity of the secondary electrons released by primary bombardment of the anode is sufficient to produce X-radiation by their impact with whatever part of the tube they strike. The X-radiation produced by the secondary bombardment is, of course, of a much longer wavelength, having been produced by lower velocity electrons. This radiation is termed soft, being readily absorbed, and is usually filtered out from the main beam by metal filters, etc.

In diagnostic work a percentage of soft radiation is desirable to show up the tissue detail in the radiograph, hence the amount of filtration is somewhat limited, and as the X-radiation produced by the secondary emission electrons may be generated in various parts of the tube, depending on the general geometry of the electrodes, the main beam of the tube will suffer distortion due to interference from secondary radiation.

The second trouble experienced from the emission of secondary electrons is due to

the fact that very high negative charges build up on the glass wall of the tube, due, of course, to the bombardment from secondary electrons, sometimes of the order of 30 to 40 kilovolts, leading to puncturing of the envelope. The high negative charge also produces considerable biasing action on the performance of the tube.

No attempt has been made to go into even the surface details of this piece of mechanism, though it is hoped that these few lines will prove interesting and constructive.

A. G. LONG,

Research Department, Newton and Wright, Ltd.

London, N.3.

Reproduction Level

WITH reference to the article entitled "New American Quality Receiver" (March 23rd) and the letter from Mr. J. R. Hughes in your issue of April 13th, I should like to say that I heartily endorse the remarks of Mr. Hughes regarding natural volume for natural reproduction. The finest receiving equipment is not worth listening to at an unnatural output level.

It is quite easy to obtain the required volume for domestic listening from an amplifier with an undistorted output of 2-3 watts. I recently made some interesting tests at home with a first-class noise meter which registers sound in phons. It was found that when the output of the set on speech was regulated to equal the intensity of actual conversation, most lifelike reproduction was obtained. I was surprised at

quality of the B.B.C. transmissions from day to day is sometimes most marked and obvious to me when listening. As a matter of fact, some of the B.B.C. transmissions suffer from excessive "top" which also requires correction, while the opposite has also been found true.

These are the conclusions that have been arrived at after listening to as many varied musical transmissions as is possible, through the medium of a reproducer that clearly "shows up" the Effects Department of the B.B.C., whose treatment of transients leaves nothing to be desired.

Reverting to the correspondents, I am afraid that they cannot be such "lovers of quality" if their views are any criterion of their reproduction. R. C. HARRIS.

London, N.4.

Early Morning Reception : Shaver Interference

I GET comparatively little trouble from vacuum cleaners, except on short waves, but the chief offender here is the proud owner of a new electric shaver; the interference this causes is terrific even at 50 yards with a road between. Luckily, I only get the trouble in the morning, but even then I am prevented from hearing any VK's or ZL's on 14 Mc/s. I am hoping the shaver develops a short or that the owner decides to grow a beard. No legislation seems to be forthcoming for the prevention of these abuses. W. H. PIERCE.

Beckenham, Kent.

Mr. P. K. Turner

IN fairness to the new Hartley Turner Radio Co., to my friends in wireless circles, and to myself, I should like to explain that I gave up all my interests in the old company—Hartley Turner Radio, Ltd.—in the summer of 1938, and have no connection at all with the new firm.

Windsor, Berks.

P. K. TURNER.

Synthetic Reverberation

Electro-optical Principle Utilised by C.B.S.

A SYNTHETIC reverberation device recently demonstrated by Dr. P. C. Goldmark, chief television engineer of the Columbia Broadcasting System, will be widely used in creating a concert-hall effect from within any broadcasting studio.

Construction of the apparatus is based on the electro-optical principle. It is built into a single rack, and its most important feature is a disc, 20 inches in diameter, rotating at a speed of about 400 revolutions a minute. The outer rim of the disc is coated with phosphorescent material.

To use this disc for synthetic reverberation, the sound is converted into electrical energy which in turn is transformed into light. A special high-pressure mercury vapour quartz lamp is used as a source of light, and a quartz lens system projects a sharp image on the disc. This light image impressed on the revolving disc's phosphorescent surface produces on it bars of light of varying intensity. Intensity of light is synchronised with the intensity of sound signal fed into the apparatus.

This light image of the sound, temporarily "engraved" on the disc, is then picked off the disc by photo-electric cells placed around its circumference. The process is complete when the secondary sound image is picked up and superimposed on the original sound.

A great deal of optical research was carried out by Dr. Goldmark and his associates in

order to evolve a method of transferring the maximum amount of light from the modulated light source on to the disc, and from the disc to the photo-cells. In order to ensure stable operation of the mercury vapour lamp serving as a light source, a cooling system was developed. It is automatically controlled by the lamp current and functions in such a way that when current in the lamp increases, and pressure in the lamp is built up, the cooling process commences. When the lamp current passes beyond a certain maximum point, the cooling automatically stops.

Paper Records

New Russian System

A RUSSIAN inventor, Skvortsov, several years ago originated a method of sound recording on ordinary paper, but he died before completing the experimental work. Further work by Russian engineers has developed the system to the point where it is ready for commercial production. A recording has already been made of an actor, Abdulov, reading one of Mark Twain's stories.

Normal methods of sound-on-film recording and reproduction are employed, but the novelty is the printing and duplicating of the sound tracks on cheap paper. The perfected instrument consists of an automatic mechanism for unrolling the paper ribbon, with the usual lenses and photo-cell for reproduction, coupled to an amplifier and loud speaker. This instrument has been christened a paper phonogram. The actual ribbon is 35-mm. wide and 150 to 170 m. in length, but these figures can be modified. Under mass production it has been estimated that a paper-phonogram record providing one hour's play-back would cost about one-fifteenth of the price of an equivalent time on gramophone records.

Between 3,000 and 4,000 play-backs of a paper-phonogram reel are stated to be possible, and millions of positives can be printed from the negative. Within 24 hours of an original performance, paper-phonogram records can be supplied to the public. Another application is the insertion of these records in newspapers and periodicals to supplement the printed matter.

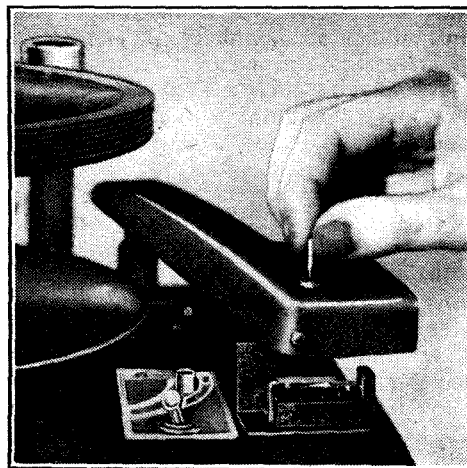

Needle loading from the top and automatic needle ejection are features of this RCA crystal pick-up. The needle is inserted in a hole at the top of the head and the point comes to rest against the bracket below, while the normal screw retainer is adjusted. To remove the needle, the screw is loosened and the pressing of a lever withdraws the retaining bracket to reveal a container into which the used needle drops.

The Wireless Industry

WESTINGHOUSE have just issued a third edition of their descriptive pamphlet No. 11H (Westinghouse Rectifiers for Telecommunication). There are three sections dealing with power supply for telegraphy and telephony, other circuit applications in telegraphy and telephony and power supplies for radio communication.

F. W. Lechner and Co., Ltd., 5, Fairfax Road, London, N.W.6, announce the introduction of 2-, 3- and 4-gang potentiometers and a wire-wound "Tropa" model for use under tropical conditions. Also a range of heavy duty rotary switches and switches with "Frequentia" insulation.

"Drydex" HT and LT batteries are now available for the Philco Model P429 receiver. The 1½-volt LT battery costs 2s. 6d. and the 45-volt HT units 3s. 9d. each. A complete unit, Type H.1157, giving 90 volts HT and 1½ volts LT and fitted with a 4-way socket is available priced 10s.

National Radio and Television Service Co., 126, Elthorne Road, Holloway, London, N.19, have developed a replacement cone assembly to be known as the "National Metacentre." It costs 27s. 6d. and can be adapted to fit most of the larger "hand made" moving-coil loud speakers.

News from the Clubs

Radio, Physical and Television Society

Headquarters: 72a, North End Road, West Kensington, London, W.14.

Meetings: Fridays at 8.15 p.m.

Hon. Sec.: Mr. C. W. Edmans, 15, Cambridge Road, North Harrow, Middlesex.

On April 21st a representative of Partridge, Wilson and Co., Ltd., lectured on "Rectifying Equipment." The lecturer brought a large quantity of apparatus with him.

On April 26th several members attended a meeting of the Golden Green Society, at which Mr. Maurice Child described his 40-metre DF gear.

Recent lectures have been given on "Rectifier Equipment," "Thermo-electric Instruments" and "Television Time Bases." A transmitting evening was also held recently at which several DX stations were contacted. Several members now have full transmitting licences.

Slough and District Short-Wave Club

Headquarters: 35, High Street, Slough, Bucks.

Meetings: Alternate Thursdays at 7.30 p.m.

Hon. Sec.: Mr. R. J. Sly, 16, Buckland Avenue, Slough, Bucks.

At the last meeting on April 27th a general discussion was held on the conditions on the amateur band.

At the next meeting, to be held this evening (May 11th), there will be a lecture entitled "High Voltage Electrical Phenomena."

Watford and District Radio and Television Society

Headquarters: Carlton Tea Rooms, 77, Queen's Road, Watford, Herts.

Hon. Sec.: Mr. P. G. Spencer, 11, Nightingale Road, Bushey, Herts.

At the next meeting, which will be held at 8 p.m. on May 18th, there will be an auction sale of members' surplus apparatus.

Wirral Amateur Transmitting and Short-Wave Club

Headquarters: Beechcroft Settlement, Whetstone Lane, Birkenhead, Cheshire.

Meetings: Last Wednesday evening in the month at 7.30 p.m.

Hon. Sec.: Mr. J. R. Williamson, 13, Harrow Grove, Bromborough, Cheshire.

At the annual general meeting held on March 29th it was stated that the total membership is now forty-five, an increase of eleven over last year.

Southend and District Radio and Scientific Society

Headquarters: Strand Chambers, High Street, Southend-on-Sea, Essex.

Meetings: Alternate Fridays at 8.15 p.m.

Hon. Sec.: Mr. J. M. S. Watson, 23, Eastwood Boulevard, Westcliff-on-Sea, Essex.

It has been arranged that the Society shall cooperate with four other clubs in arranging field days during the summer. The Southend Society will arrange a field day on May 14th, and also a field night on September 16th-17th. On June 11th a field day will be arranged by the Romford Society, the Welwyn Club being responsible for the July 9th event and the Brentwood Society for that of August 20th. The final field day will be held on October 15th and will be arranged by the Ilford Society.

UNBIASED

Piracy on the High C's

I SEE that certain musicians of what may be termed the "so superior" class are on their hind legs once more denouncing people who listen to symphony concerts by wireless, instead of coming along to the actual concert hall and so increasing the gate money. Music reproduced by mechanical means is, we are told, at best but a poor travesty of the real thing. Mechanical means! Ye Gods! What on earth is a piano, or any other musical instrument but a device for reproducing music by mechanical means? I am not to be put off by people who would argue that a piano is not a reproducer of music, but a primary producer of it. It is, of course, nothing of the kind, but is merely a device to enable a man to reproduce certain combinations of sound written down by the composer.

It will be seen, therefore, when the question is thoroughly examined, that all music is reproduced by mechanical means, and so this fatuous argument against broadcasting which the so-called musical highbrows are once more putting forth, is without substance. It is true that there are plenty of very poor wireless sets about—far too many of them, in fact—but so also are there plenty of indifferent violins. A first-class wireless set, however, is entitled to rank equally with a first-class violin. Neither is perfect, although naturally the violin and other musical instruments, having had several centuries start are, as yet, still somewhat ahead of the wireless set.

This brings me to another question.

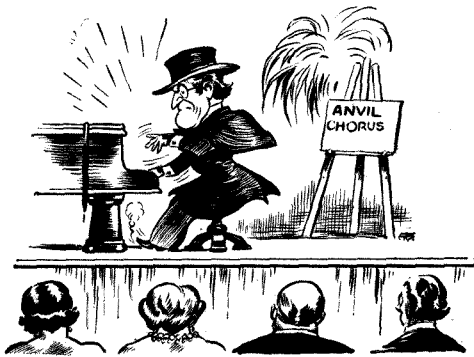

Not Paderewski.

What actually is the difference between a pianoforte recital as given by me and one given by Paderewski? That there is a difference I will certainly admit. But it has nothing to do with the fact that Paderewski possesses some "mystic" powers which I lack. There is nothing mystical or supernatural about it; it is simply due to the fact that, although we both press the correct piano keys, Paderewski does so with just the correct

degree of pressure and the correct time intervals necessary to produce certain effects from the piano, and I do not. If properly analysed, Paderewski's playing could all be reduced to an exact degree of lb. per square inch and milliseconds of time. It is, in fact, all a question of elementary physics.

Let us, therefore, have done with all this palpable nonsense of the "so-superior" musicians I have mentioned, who are decrying home listening. Let the cold clear light of science shine on it, and all this pseudo-musical mysticism vanishes into thin air. Actually I very much doubt whether these anti-radio musicians themselves believe in all the diatribes they utter against broadcasting. I am coming more and more round to the opinion that in this commercialised age, the real cause of their worries is exactly the same as that which inspires football magnates to be so bitter in their views on television, namely, fear of a substantial falling-off in their gate money if they don't try to check this piracy of their profits.

Tellies or Talkies?

SEVERAL readers have written to me criticising my attempt to reform the cinemas by inducing them to provide alternative programmes by means of a screen at each end of the building. The chief objection lodged against my proposal is that the slope of the cinema floor would, for obvious reasons, prevent it being possible to have a screen at either end. I must be credited with a little common sense and, if I had my way, I would march in with my army of occupation and sweep away sloping floors and other archaic ideas which the cinema has borrowed from the theatre.

To enable people in the back seats to see more clearly without a sloping floor, I would put the screen several feet higher than it is at present, and to prevent front-seat patrons having too oblique a view, I would tilt the screen slightly forward. Each seat would be built on the lines of a dentist's chair so that people could adjust it to the correct angle for avoiding a crick in the neck, all adjustments being carried out by built-in electric motors controlled from the arm of the chair.

You may well ask, as the Editor did, what has all this to do with wireless? My reply is that the cinema magnates have asked for it by their frightened plea that television, if unrestricted, will bankrupt them in two years. There will be no question of television bankrupting them if they will put their house in order and modernise their establishments, and I am, therefore, doing what is after all only my duty in endeavouring to get them to see

By FREE GRID

what is really leading them to Carey Street, and to leave television alone.

To continue, therefore, with my proposals, I would have an arrangement whereby, on pressing the appropriate button, each patron's "dentist chair" would sink beneath the floor into a well-

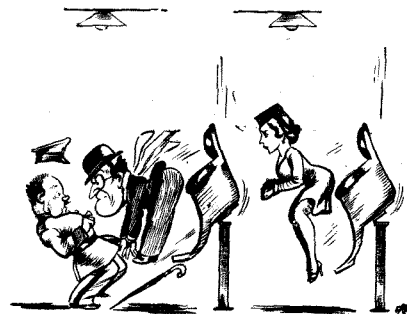

Automatic ejection.

lighted subterranean chamber, all loading and unloading being done in comfort down below. An attendant would load people into their seats under the floor, and at the same time would set a time switch which would automatically cause each seat to descend and eject its occupant when he had seen the pictures round once, and, in this way alone, cinema proprietors would soon recoup their capital expenditure on my proposed scheme, as they would more than double their present turnover of patrons.

Incidentally, I may point out that my idea would completely abolish the detestable practice of the person at the end of the gangway having to keep jumping up and down like a jack-in-the-box every time somebody in the row of seats wants to go in or out. It would also enable people to wear headphones without the annoyance of other people tripping over the leads. To prevent light shining into the auditorium from the subterranean chamber through the aperture in the floor when a seat was down below, a shutter would automatically slide over the hole, all subterranean-chamber lights being automatically switched off at the moment when a seat was actually passing through the floor.

If the cinema magnates refuse to accept my proposals then, of course, they can ruin themselves in their own way. No doubt, even if television did cause people to acquire a distaste for films they would still patronise the old cinema buildings as, even nowadays, some people seem to go there merely to eat and chatter, and, in fact, do anything but look at the pictures. It is doubtful whether many people would even notice that pictures were no longer being shown.

Random Radiations

An "Inert" Adventure

A WEEK or two ago I wrote of the inert dry cell, or the "cell, electric, inert," to give it its Army designation, wondering whether it still existed. It does, as a rather amusing little adventure that befell me the other evening proved. I was taking a class of signallers belonging to a Territorial unit that has not been in being for very long. After telling them how to get to work, I handed out a batch of brand new field telephone instruments and instructed the class to put in the dry cells—a pair in series—and connect them up. All the instruments with a single exception were found to be in working order. One was completely dead. It was brought to me to look over, and at first I couldn't find anything amiss. The connections seemed to be all right and there was no obvious reason why the thing shouldn't do its stuff. For some reason or other, I pulled out the cells and there was the explanation staring me in the cold printing on their cases; one was a dry cell; the other, an inert. As the latter hadn't been dosed with water, it wasn't pulling its weight. Somehow or other it had strayed in amongst a boxful of ordinary cells.

Just the Thing

It was good to see Mr. Stanley G. Rattée's letter commenting on my remarks about inert cells. I haven't met him for a long time now, though he is one of the old stagers of wireless. I entirely agree with his suggestion that an HTB made up of inert cells would find a ready market amongst those who have acquired battery sets with an eye to A.R.P. So long as they are not filled with water, inert cells can be stored almost indefinitely; a battery of this kind would therefore be the very thing for the job. And I don't see why large inert cells should not be used for heating the filaments of the new 1.5-volt low-current valves. If the set intended for the dugout could be put away, batteries and all, with the certainty that it could be made to function as soon as it was wanted (let's hope it never will be!) by the simple process of running a little water into the filling holes, a lot of worry would be saved. Dry batteries unfortunately can't be relied on if they're kept in store for more than a few months on end.

Saucer Records

WRITING from Frimley, a reader tells me of some queer experiences with gramophone records. Some time ago he ordered a set of a certain make containing a recording of a famous symphony. When they arrived he proceeded to play them over by means of a crystal pick-up and *The Wireless World* Quality Amplifier. All went well as far as the end of the second movement; but when the third began there came a sudden agonising drop in the pitch. On examination the record proved to be shaped rather like an upside-down saucer. Such was its convexity that it didn't get a proper grip of the spindle and so was driven much too slowly. He returned the faulty record, and, soon after, received another in its place. This turned out to be almost, if

By "DIALLIST"

not quite, as bad as the first, and again a return was made. When they came to look over their stock, the manufacturers had to admit that all examples of this record were faulty. A new pressing had to be made, and it was seven weeks before a satisfactory record turned up.

They Will Slip Through

What my reader can't understand is that a misshapen batch of records should have escaped the vigilance of all testers and have been passed into stock. It is rather surprising; but there is always the possibility that the records were flat enough when they passed from the factory into the stockroom *via* the test department. They may have warped through being badly stored. One would have thought, though, that such a serious deformation could hardly have escaped notice when they were passed out for sale. Still, it's astonishing what faults can slip through the best designed and most carefully run test department. To those who say that nothing defective should ever get through a good test room I always say: Pay a visit to the Mint; watch the vast number of tests to which every coin is subjected at each stage of its making. You'll feel convinced that no really misshapen coin, or any that was much below or above the standard weight could possibly pass into circulation. Then go to the Mint's museum and look at the displays of coins with the most glaring faults that have been returned by the banks.

A Television Surprise

SOME of the answers given by viewers in reply to the B.B.C.'s questionnaire on television have come as a surprise to me, though I don't think that there's much doubt that the opinions expressed must represent the views of the majority of owners of television receivers. I quite expected that viewers would reverse the opinion expressed by listeners on the subject of women announcers. Listeners would not have them at any price; viewers prefer them. The reason isn't far to seek. Women's voices don't somehow fit in with the purely oral news bulletins; but they go very well with television's light fare. And the B.B.C. very wisely chose television announcers who are a delight to the eye as well as to the ear. What does surprise me is that O.B.'s take second place to variety and light entertainment in general in the estimation of viewers. I'd have said that O.B.s would very easily head the poll.

Changing Opinions?

That just shows how easily one can form an erroneous estimate, even though it is founded on the opinions expressed by a goodly number of television owners. Quite a few of my friends have vision receivers, and certainly I've found far more enthusiasm amongst them for races, boxing matches and other sporting and public events than for variety as television enter-

tainment. It's not impossible that there has been a gradual change of opinion in recent months owing to the improved (and still improving) standard of televised light entertainment. At one time it was rather sorry stuff, and some who have owned receivers for a goodish time may have formed such a poor opinion of it that they ceased to turn it on. Now that it is of so much better quality they are discovering its merits and deciding that it deserves first place amongst the diversions offered by television.

American CR Tubes

VARIOUS American manufacturers, I notice, are beginning to advertise cathode-ray tubes for constructors of vision receivers. Both they and the firms which specialise in "kits" are obviously expecting amateur experimenters and home constructors to begin in a small way, for most of the tubes announced are quite little fellows. The 3-inch screen seems to be the size that they expect to be most in demand, though several 5-inch tubes are available, those who announce them do so rather with bated breath; they are spoken of as just the thing for the man who intends to build something outstanding in the way of receivers. I wonder whether American manufacturers will eventually find as some of ours have done that their best sellers prove after all to be the vision receivers with the larger screens. You'd imagine that the midget set selling at a modest price would find a ready market; it goes pretty well, but in many cases the man in the street feels that it's better worth his while to pinch and scrape a bit in order to be able to buy a receiver with a screen measuring at least 7 inches by 5. It will be interesting to see what kind of prices the big American valve concerns ask for their cathode-ray tubes.

Murphy B69

THIS is a battery superheterodyne which has been developed on the same lines as the "70" series of mains receivers described in our April 20th issue. It represents the maker's estimate of the minimum specification for the reception of broadcasting on short, medium and long waves, and employs a superheterodyne circuit with triode hexode frequency-changer, pentode IF amplifier, double-diode-triode detector, AVC rectifier and first AF amplifier and a single pentode output valve.

Improved quality of reproduction and efficiency have been achieved by the inclusion of a permanent magnet of unusual size in the loud speaker. The HT consumption is 10 mA on medium and long waves, 12 mA on short waves, and the total LT current is 0.45 amp.

The cabinet is similar in design to that of the A70, but there is no provision for optional tuning units. The price is £9. Space is provided for any standard 120-volt HT battery, and a moulded tray prevents acid creeping from the accumulator.

Recent Inventions

Brief descriptions of the more interesting radio devices and improvements issued as patents will be included in this section.

SCANNING SYSTEM

THE electron stream in a cathode-ray tube is usually controlled by the electrostatic field set up between two parallel deflecting plates, the direction of the control field being at right angles to the movement of the stream and therefore having no decelerating effect on the stream. By contrast, it is now proposed to control the stream by reflecting it from an equipotential surface set up inside the tube. The effect is first to slow up the stream as it approaches the equipotential field, and there to reverse it in direction.

As in the case of ordinary light, the angle of incidence of the electron stream is equal to the angle of reflection. Accordingly, as the contour or inclination of the equipotential surface is varied, the angle through which the stream is reflected will follow suit, and the stream can thus be made to travel over a fluorescent screen. In practice, a steady equipotential field is first created by applying suitable biasing potentials to a pair of parallel electrodes, and the stream is then deflected by varying the voltage on one of the electrodes at scanning frequency.

O. Klemperer. Application date May 1st, 1937. No. 498511.

FREQUENCY MULTIPLIERS

THE figure shows a two-valve circuit which is stated to be capable of delivering as much as 10 watts of energy at a frequency corresponding to the tenth harmonic of the input frequency. The first pentode generator V is stabilised by a piezo-electric crystal Q having the same frequency as a "tank" circuit L, C, and is coupled to the grid of a

second valve V₁ through a condenser. The output from the second valve is back-coupled through a circuit L₂, C₂ (tuned, say, to the tenth harmonic of the fundamental frequency of the crystal Q) to the pentode output circuit L₁, C₁.

The effect of this coupling is comparable with the action of two pendulums, one swinging ten times faster than the other, the slow one giving an impulse to the fast one each time the two come into phase. The circuit L₂, C₂ corresponds to the fast, and L₁, C₁ to the slow, pendulum, the transfer of energy being from the anode of V to the grid of V₁. The multiplied frequency is drawn off at the output terminals T.

Marconi's Wireless Telegraph Co., Ltd. (assignees of J. L. Reinartz). Convention date (U.S.A.), April 23rd, 1937. No. 499088.

DIRECTION-FINDERS

THE figure shows an aerial system designed to minimise the so-called "night effect" in direction-finding. The two main frame aerials A and A₁ are spaced apart, with both windings set parallel to each other, and are mounted for rotation about a common shaft S. The two aerials are coupled in phase-opposition through coils L, L₁ to a common receiver R, the output from which is applied to one pair of deflecting plates in a cathode-ray indicator tube T.

Mounted on the shaft S is a third or auxiliary frame aerial B, the pick-up from which is applied separately through a receiver R₁ to the second pair of deflecting plates in the cathode-ray tube.

The arrangement gives a simplified indication both of the direction and "sense" of incoming

or separate pairs of lamps may be fixed in position at the sides of each slip, and lit up as required.

The station-pointer is moved along a horizontal base, parallel to the strips, by a cord-and-pulley mechanism operated by the control knob. Or a "shadow" thrown by a light at the rear of the glass scales may serve as a pointer.

Marconi's Wireless Telegraph Co., Ltd. Convention date (U.S.A.) June 30th, 1936. No. 497951.

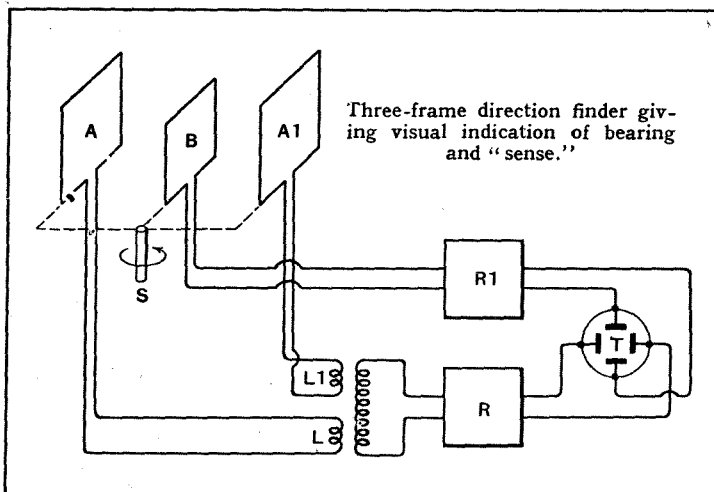

signals. For instance, the trace on the fluorescent screen of the cathode-ray tube will be a straight line in the normal "maximum" position of the aerials, i.e., when the pick-up on the frame B is greatest, and that from the two frames A and A₁ cancels out. As the aerials are rotated into other settings, the trace formed on the fluorescent screen will vary from an ellipse to a circle. The "sense" of the signals is indicated by observing the movement of the trace as the shaft S is swung to right or left, the correct bearing being that on which the trace moves with the shaft and not against it.

Telefunken Ges. für drahtlose Telegraphie m.b.h. Convention date (Germany), June 12th, 1937. No. 498995.

TUNING INDICATORS

A MULTI-BAND receiver is fitted with a tuning indicator in the form of a series of transparent strips of glass, each marked with its appropriate station scale. The various strips are mounted one behind the other, lengthwise, in slots in the same pair of end-supports, so that they form a practically continuous surface, though each is separated from the other by a thin strip of opaque material.

The particular indicating strip selected is lit up by a pair of lamps which shine their light through the slots made in the end-supports. A single pair of lamps may be used, in which case they are moved into position by suitable gearing operated by the wave-change switch;

"WATCH-DOG" SETS

RELATES to an installation of the kind used at sea to give automatic warning of the receipt of the S O S call or other emergency signal. According to the invention, the set is constantly and automatically supervised by a so-called "cycling" device, which serves to produce locally a weak signal similar to that for which the receiver is "watching."

So long as the installation is in proper order the arrangement is such that the "alarm" proper cannot be actuated by the local "test" signals. But should any part of the installation develop a defect, then the alarm is automatically rung by the test signals, as a warning to the wireless operator that the "watch" is no longer reliable. Between the testing periods, the receiving circuits are, of course, ready to respond to any genuine emergency call. In other words, the alarm can only be sounded (a) on the receipt of a genuine long-distance call, or (b) when the local "testing" signal shows that the receiver is out of repair and requires attention.

Wallace and Tiernan Products, Inc. Convention date (U.S.A.) June 20th, 1936. No. 499028.

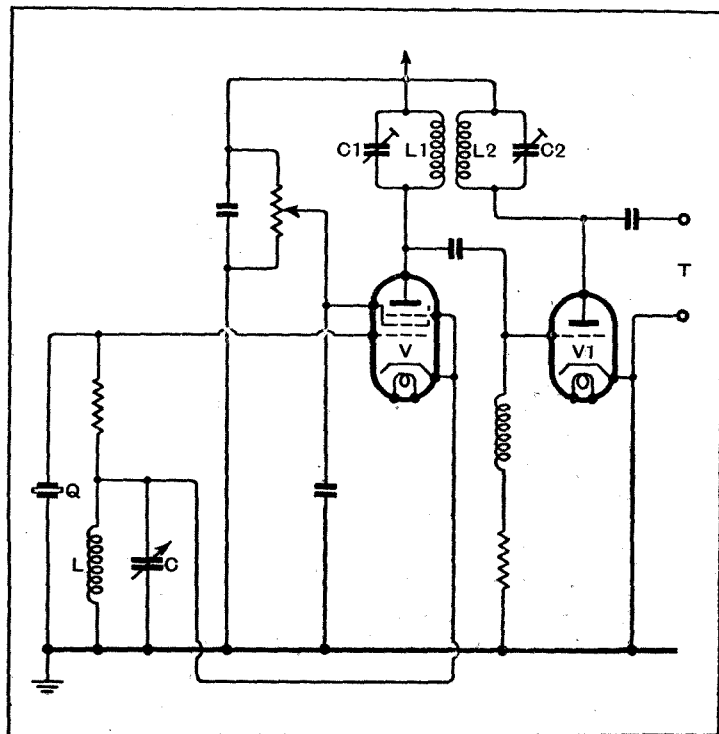

Frequency multiplying circuit for operation at the higher harmonics.

The British abstracts published here are prepared with the permission of the Controller of H.M. Stationery Office, from specifications obtainable at the Patent Office, 25, Southampton Buildings, London, W.C.2, price 1/- each.

The Wireless World

THE
PRACTICAL RADIO
JOURNAL
29th Year of Publication

No. 1029

THURSDAY, MAY 18TH, 1939.

VOL. XLIV. No. 20.

Proprietors : ILIFFE & SONS LTD.

Editor :
HUGH S. POCOCK.

Editorial,
Advertising and Publishing Offices :
DORSET HOUSE, STAMFORD STREET,
LONDON, S.E.1.

Telephone : Waterloo 3333 (50 lines).
Telegrams : "Ethaworld, Sedist, London."

COVENTRY : 8-10, Corporation Street.
Telegrams : "Autocar, Coventry." Telephone : 5210 Coventry.

BIRMINGHAM :
Guildhall Buildings, Navigation Street, 2.
Telegrams : "Autopress, Birmingham." Telephone : 2971 Midland (5 lines).

MANCHESTER : 260, Deansgate, 3.
Telegrams : "Iliffe, Manchester." Telephone : Blackfriars 4412 (4 lines).

GLASGOW : 26B, Renfield Street, C.2.
Telegrams : "Iliffe, Glasgow." Telephone : Central 4857.

PUBLISHED WEEKLY. ENTERED AS SECOND CLASS MATTER AT NEW YORK, N.Y.

Subscription Rates :
Home and Canada, £1 10s. 4d. ; other countries, £1 12s. 6d. per annum.

As many of the circuits and apparatus described in these pages are covered by patents, readers are advised, before making use of them, to satisfy themselves that they would not be infringing patents.

CONTENTS

	Page
Editorial Comment	455
New Communication Receiver ..	456
Dry-cell LT in U.S.A.	459
"The Wireless World" DC Mains Super : Circuit Arrangement..	460
Problem Corner	462
Television Programmes	462
Cathode-Ray Amplifier Tester ..	463
Letters to the Editor	466
News of the Week	467
Frequency Modulation in America (concluded)	469
Invicta New Junior Portable: Test Report	471
Television Topics : Saw-tooth Current Waves	473
New Apparatus	474
Random Radiations	476
Direct Recording Blanks	477
Recent Inventions	478

EDITORIAL COMMENT

The Post Office Relays *Is the Position Satisfactory ?*

WHEN the Post Office some considerable time ago proposed the development of a relay service in Southampton as a starting-off point before extending such a system on a national scale, the project met with so much opposition that the Post Office abandoned the idea of carrying it out in that location. More recently the Post Office has announced the intention of developing their own relay system on a national scale as a service in addition to, or in competition with, the privately owned relay systems whose licences the Post Office has now renewed for a further term of ten years.

The question has recently been asked: Why should the radio industry, which contributed so actively to opposing the Post Office scheme for Southampton, now apparently acquiesce in the present Post Office proposals? In our view the suggestions made in connection with Southampton and those now put forward are so fundamentally different that the whole outlook on the proposition has changed.

In the case of Southampton the proposal was to supply the broadcast programmes at audio frequency, which in all probability would have necessitated the use of a particular type of loud speaker and terminal apparatus at the listener's end, and would have made a wireless receiver unnecessary to anyone satisfied with a choice of the two or three alternative programmes which the service could provide. Under the new scheme, with programmes supplied at radio frequency, a normal type of wireless receiver becomes a necessity, and in consequence the radio industry not only has nothing to fear in the way of a falling-off in demand for sets, but the Post Office has given firm assurances that there will be no attempt made to market apparatus for the purpose, but the listener will purchase his equipment through the usual channels.

If the Post Office had developed relays on an audio-frequency basis there would have been every justification for fearing

that broadcast listening would have had a most serious set-back and it would ultimately have interfered with the freedom of the individual to receive programmes at will. The cost of wireless receivers would also have increased as a result of a reduction in demand; so that receivers might again have become a luxury commodity as they were in the early days of broadcasting.

Now the position has, we think, been satisfactorily cleared up, and the only question which it seems necessary to ask is whether, except for the purpose of meeting special emergency, the expenditure of the Post Office on a relay distribution is justified. It will only give three or four of the same stations which are already available under normal conditions of reception, and the only advantage which the Post Office scheme can claim, as far as the listener is concerned, will be greater freedom from electrical interference and perhaps a higher standard of quality. This latter advantage would, of course, justify the scheme in the opinion of a great many listeners, but only time will show how far the standard of quality will be improved.

Gas and Electricity *The Influence of Wireless*

IN a recent annual report of a gas corporation a very frank admission was made that the demand for a mains supply of electricity for a wireless set has frequently been a factor in the ousting of domestic gas lighting, and a reference was made to the future possibility of obtaining wireless reception by means of gas-operated appliances.

However effective gas equipment of this kind might prove to be in time to come, we think that electricity has so long a start that any gas appliance, whether for operating the receiver directly or used for generating electricity for the receiver—which latter we presume to be the arrangement in question—would have a very uphill struggle to retard the ousting of gas where electricity is sought for operating the modern broadcast receiver.

New

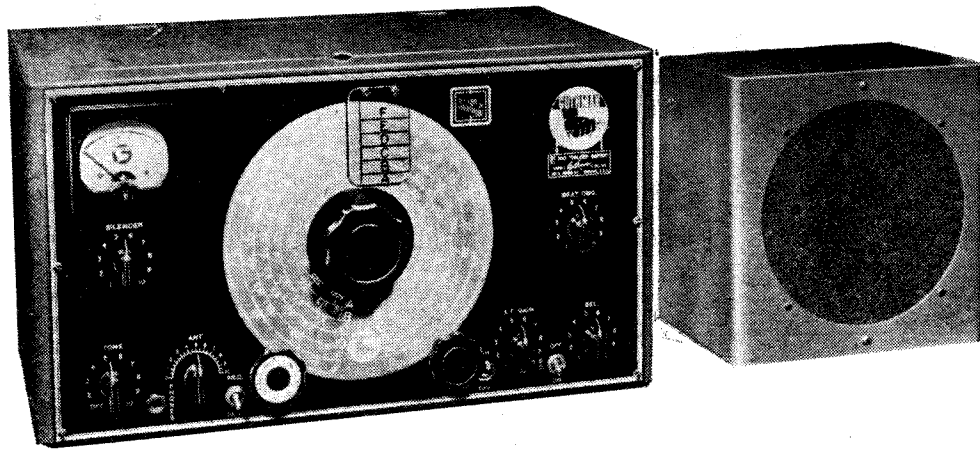

IN this article there appears a description of an American communication receiver which is especially interesting in view of the use which is made of regeneration. It is obtained at signal-frequency and also at intermediate frequency, and as a result very high sensitivity and selectivity are obtained with a simple circuit

By **McMURDO SILVER** (Edwin I. Guthman and Co., Inc., Chicago)

THE use of regeneration to obtain high sensitivity and selectivity is one method of approaching the engineering goal of high efficiency combined with minimum cost and complexity. In a carefully designed receiver it permits the elimination of several undesirable characteristics and enables the attainment of results directly comparable to those given by more complex methods. Ever since the high-performance possibilities of the double-regenerative super-

heterodyne known as the Jones "Super-Gainer" were revealed to amateurs in 1935 the writer has been amazed that no factory-built communication receivers have utilised this idea. The reason probably is that such receivers have closely followed broadcast receiver design technique, to which regeneration, in the U.S. at least, is anathema, since Mrs. John W. Public can't be taught how to use it.

Knowing what can be had from an easily operated double-regenerative receiver, the writer recently designed a communication receiver along these lines. The performance came up to his fondest expectations, and even exceeded them in regard to the signal-noise ratio.

By using a regenerative frequency-

changer, regenerative IF amplifier, diode second detector, pentode AF and tetrode output stages, very high sensitivity and selectivity can be obtained with a very good signal-noise ratio. In the "Silver-Super" here described the signal-noise ratio actually measures from 25:1 and 50:1; specifically, at an input of one microvolt absolute the signal output is 50 milliwatts, of which the noise component is between only 1 and 2 milliwatts!

This same technique also provides continuously variable selectivity, which, at the turn of a knob, can be adjusted to anything between the extremes of 12 kc/s and less than 1 kc.—necessary for single-signal CW telegraph reception. Another advantage lies in the fact that through this

Fig. 1.—The complete circuit diagram of the receiver is shown here. Signal-frequency regeneration is obtained with the aid of C1 and C2, and IF regeneration by slightly augmenting the grid-anode capacity of the 7A7 IF valve.

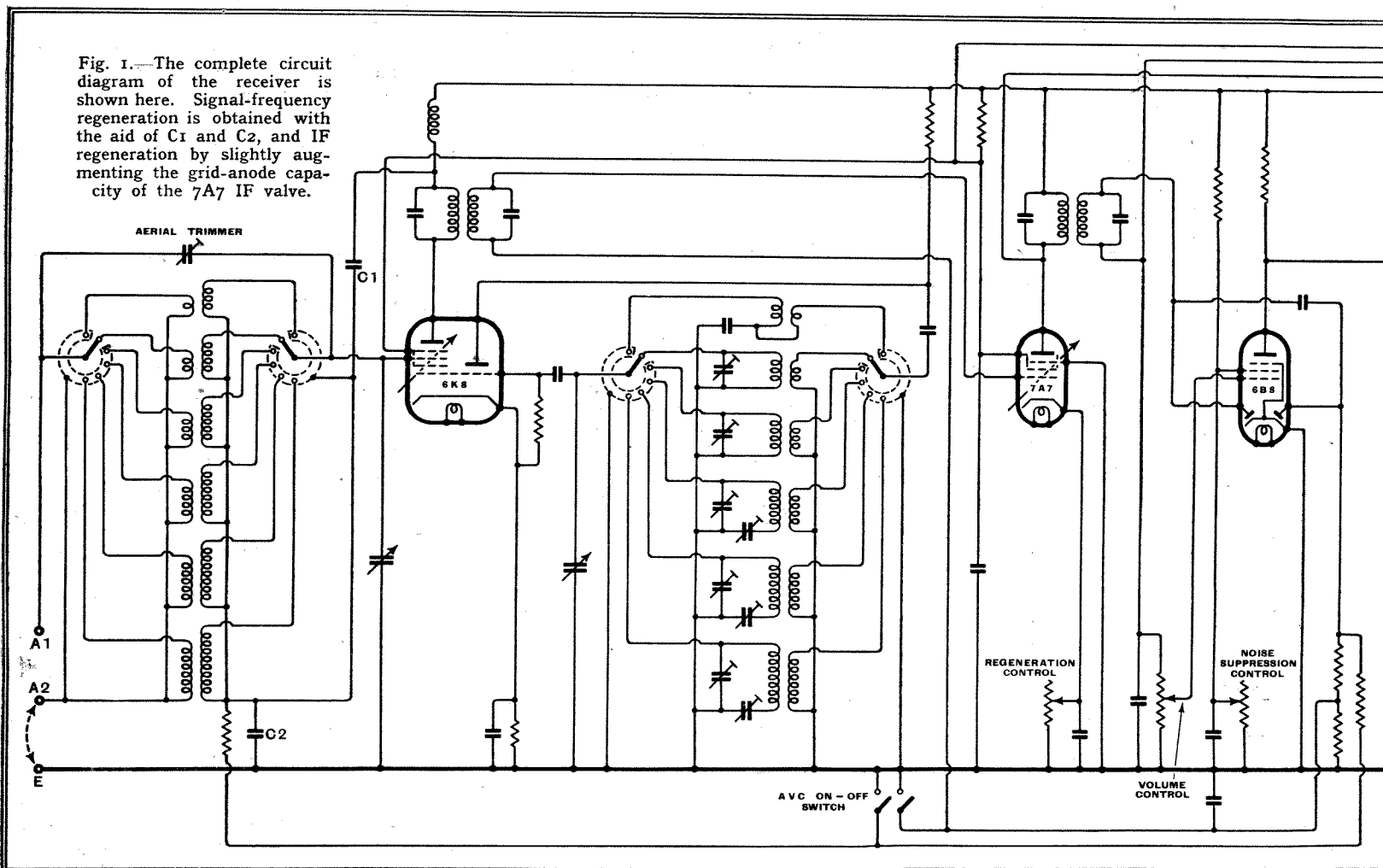

Communication Receiver

A SUPERHETERODYNE WITH DOUBLE REGENERATION

technique practically all of the difficulties encountered in the home construction of a modern communication receiver are eliminated, and it becomes a simple matter to "align" such a receiver at home without any test oscillators or test gear whatsoever; received signals alone are sufficient when one or more IF transformers are factory pre-aligned.

Another advantage of double-regenerative superheterodynes, or of any receiver using regeneration, is one which is very important where service check-up is at a premium, as in the case of expeditions. In any receiver depending upon "repeater" gain through a multiplicity of valves and components, progressive slow

deterioration of the parts seriously impairs results. In a regenerative receiver such slow deterioration merely means that the regeneration control must be advanced a little farther. This may seem to be a pointless argument if high-quality parts are used, but it is not, for, no matter how good any part may be, the possibility of deterioration, if not actual failure, is always present. So important has this factor been to a significant expedition of scientific investigation shortly sailing for far-distant points that the "Silver-Super" won selection almost "hands down," particularly after its performance had been checked against conventional receivers.

The receiver here described has a 6K8

regenerative frequency-changer, regenerative 7A7 "loctal" all-glass IF amplifier, 6B8 diode detector, AVC, first AF stage and noise limiter, and 7C5 beam power valve. As accessories, beside the fundamental purpose of signal amplification, a 7A7 is used as a beat oscillator to give single-signal CW reception, a 6SF5 single-ended triode for S-meter operation, a VR150 automatic HT voltage regulator, and, of course, a power supply rectifier—in this case an 80.

The wavelength range selected as essential to present-day amateur operation was 5 to 625 metres—specifically 480 kc/s to 61 Mc/s. Such a range in a single receiver covers every amateur band at present amenable to conventional engineering treatment, the broadcast band, and the 600-metre commercial band. Such a range automatically demanded a high LC ratio, and with the sensible tuning condenser value of 140 μF automatically broke up into six bands each of about 2.2:1 frequency ratio. Each band uses individual coils, with all unused coils shorted out of circuit and with every coil mounted directly on wave-change lugs for short leads. Ceramic switch insulation was discarded because of mechanical difficulties, and the new "X2B" insulation was selected instead.

RF Regeneration

No RF amplifier was even considered, since gain and image rejectivity at the higher frequencies could not be obtained to any worth-while degree with any simple single stage. Instead, regeneration was employed in the frequency-changer. The circuit diagram of Fig. 1 shows how this was obtained, not as a variable function, but as a fixed gain contribution.

With a 6K8, having the cathode connection common to the mixer and oscillator sections, cathode regeneration could not be employed, since it would involve highly undesirable mixer-oscillator coupling. The use of a reaction coil would involve extra switching operations and would also reduce the high-frequency range of each wave band. So a new method was devised. An RF choke in the anode circuit of the mixer provided an RF impedance, some of the voltage across which could be coupled back to the grid circuit. This idea is really very simple and works out very nicely. The choke itself had to be designed to present the needed RF impedance over the entire range of 480 kc/s to 61 Mc/s, and in designing it several interesting facts were discovered. In appearance it is just an ordinary 10 mH RF choke, except that it is wound on a ceramic dowel and the

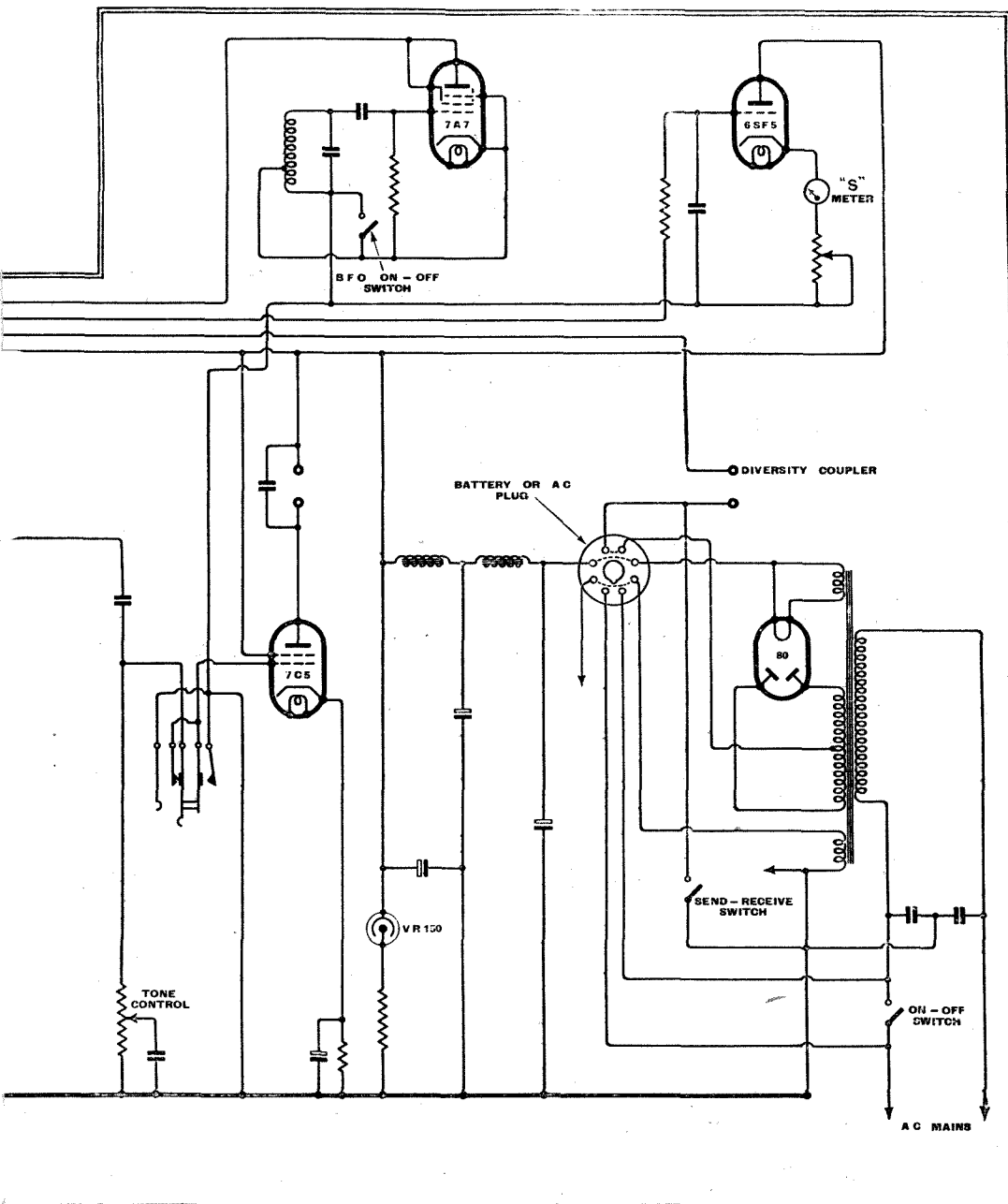

New Communication Receiver—

coil is very narrow. The fact that it works at 5 metres as well as at 500 is due to the careful choice of the physical size and shape, the wire size and insulation, as well as the winding pitch. The RF voltage across this choke is tapped off in the desired amount through the condenser C1 and fed back to the low potential end of the grid circuit—to the AVC return. The ratio of feed-back capacity C1 to C2 determines the degree of regenerative feed-back. Since high-impedance aerial primaries are employed, which prevent different aerial characteristics from reacting upon the first tuned circuit, no question of "dead spots" occurs, and this regenerative feed-back may be made fixed. Thus mixer regeneration introduces no extra control, critical or otherwise, yet gives more gain and selectivity at the higher frequencies than could a non-regenerative RF stage. Because it sharpens up tuning, a manual aerial trimmer condenser is provided. It is not critical in setting, but is a simple way of getting the very maximum out of the mixer as well as a means of eliminating five or six internal trimmer adjustments. The full experience gained in the design of a precision frequency meter of extraordinarily high-frequency stability was

willing to turn on heaters an hour or two before the start of operation if by so doing warm-up drift is eliminated, as it is in the "Silver-Super."

IF Regeneration

The IF amplifier uses one of the new all-glass 7A7 "Loctal" RF pentodes. This tube has no base, socket pins being set right into its glass "stem"; has low inter-electrode capacity; practically no lead inductance; is fully self-shielded, and has higher gain than the older 6K7 or even the new single-ended 6SK7 tubes. It is fed by a high-Q permeability tuned 455 kc/s IF transformer, which, using silver-plated-on-mica tuning condensers, has all the stability of air-tuned transformers with smaller size and higher gain. A second similar transformer couples this 7A7 to the diode second detector. Regeneration is obtained by slightly augmented grid-anode capacity at the 7A7 socket and by very high IF transformer coil Q. It is controlled by cathode bias variation, with normal operation just below critical regeneration, which occurs at optimum bias.

Any attempt to regenerate ordinary 455 kc/s IF transformers results in a frequency shift of something like 2-10 kc/s,

the usual frequency shift with regeneration variation. Actually, the IF amplifier is never operated in an oscillating condition for CW reception. Regeneration is used only to get gain and crystal selectivity, and the separate beat-frequency oscillator tube is used for CW. This allows the IF selectivity to be made so sharp that when the beat oscillator is offset 1,000 c/s, so that the loudest beat of 1,000 c/s is at IF resonance, the second audio beat (audio image) 2,000 c/s away is practically inaudible. Single-signal CW reception is thus obtained, while a bit less regeneration gives phone selectivity which is a joy and a delight in cutting through QRM.

The diode second detector and AVC circuits are essentially conventional, except for choice of optimum circuit constants and splitting of the AVC voltage to the mixer and IF valves in the best proportions for AVC. An AVC on-off switch is, of course, provided. To be really useful the S-meter should not be in an amplifier anode circuit or it will not register on signals which are below the AVC delay bias. So a 6SF5 single-ended triode is used as a valve-voltmeter to read signal voltage appearing across the diode load resistor upon the scale of the calibrated S-meter in its anode circuit. A variable cathode resistor allows initial

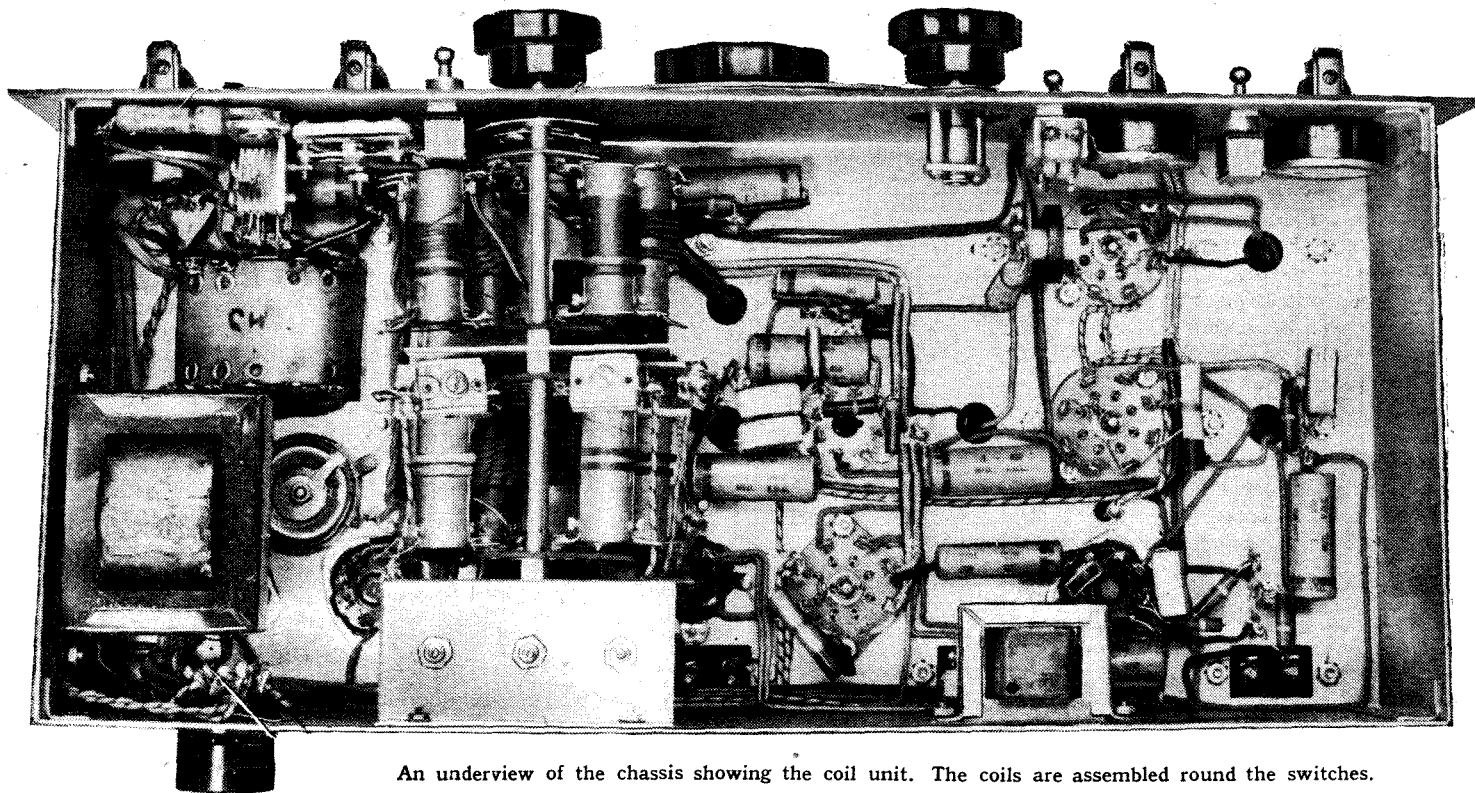

An underview of the chassis showing the coil unit. The coils are assembled round the switches.

brought to bear on the oscillator circuit, with the result that it is very stable indeed. Two further assurances of such stability were incorporated. One is a VR150 automatic voltage regulator tube, and the second is a send-receive switch which cuts voltage to all valves—even HT voltage to the filter itself. This arrangement allows valve heaters to be run continuously at low power cost—less than 30 watts is consumed by all heaters—so that the usual "warm-up" drift is entirely absent. Even the penuriously minded operator will be

enough to lose a signal entirely as regeneration is varied. The remedy lies, among other tricks of the transformer engineer, in using very loose primary to secondary coupling in the regenerated transformers. This also desirably increases selectivity, but reduces gain. This last is of no practical consequence, however, since regeneration gives all the gain that can be used. If the receiver builder will remember this point the next time he builds a regenerative IF amplifier, and uses transformers specifically designed for such use, he can escape

"setting up" of the meter scale for correct readings.

By using a diode-pentode for the detector and AF stage instead of the usual diode-triode, a noise limiter, which is as effective as it is simple, becomes possible. The pentode of the 6B8 is used as an AF amplifier, its grid being fed from the arm of the potentiometer forming the diode load. This pentode has the characteristic that its "saturation" is controlled by its screen voltage; that is, the strength of the signal it can pass is

New Communication Receiver—

governed by its screen voltage. Nothing is easier than to provide a screen voltage rheostat, with the result that screen voltage can be set so that the pentode will just pass as loud a signal as may be tuned in, but no more. Thus it cannot pass noise crashes louder than the signal. The net result of this limiting action is to

tery and vibrator, or generator HT supply, can be connected by another plug. It also brings out to this plug the send-receive switch and the on-off switch, so that both function on either AC or battery operation. Plenty of space is left in the back of the set cabinet for a vibrator or generator HT supply—even for a complete dry battery supply—not to mention

tion receiver is any better than the controllability of its operating functions, front panel control has been made quite complete. The large satin-chromium tuning dial is 7 $\frac{3}{4}$ in. in diameter, with six accurately calibrated wavebands occupying 324 degrees of its circumference, with the high-frequency bands at the outside where the effective dial scale length is greatest—21 $\frac{3}{4}$ in., to be exact. Around this outer dial edge is a 500 division scale which is directly readable to one part in 5,000 against the 0-10 decimal indicator scale. This, plus the great effective dial scale length, provides what might be called "spread band" tuning in that each frequency range is unusually widely spread out for a main dial. For those desiring it an 0-200 division, 4 in. diameter band-spread dial is available which is driven from the main dial shaft through a 12:1 positive, no-backlash, gear train. Easily mounted and with its band-spread dial "peeking out" at the upper right of the main dial, it gives over eleven feet of dial scale for each 2.2:1 frequency band with, through its own 0-10 decimal indicator, a direct readability to 1 part in 21,600. Dial drive is direct through its centre knob for fast band-skipping, or 15:1 vernier through the large knob at its lower right, properly placed for long hours of fatigue-free tuning. Other controls are noise limiter, tone, headphone jack, antenna trimmer, send-receive, wave-change, vernier tuning, AVC on-off, audio gain, BFO on-off, IF gain, selectivity, and BFO pitch control. The panel is finished in silver on etched-black, and in its grey enamel steel cabinet with hinged cover the set presents an appearance which is unusual among communication receivers; in fact, the stark and strictly utilitarian appearance that has come to be associated with this type of set has been entirely avoided.

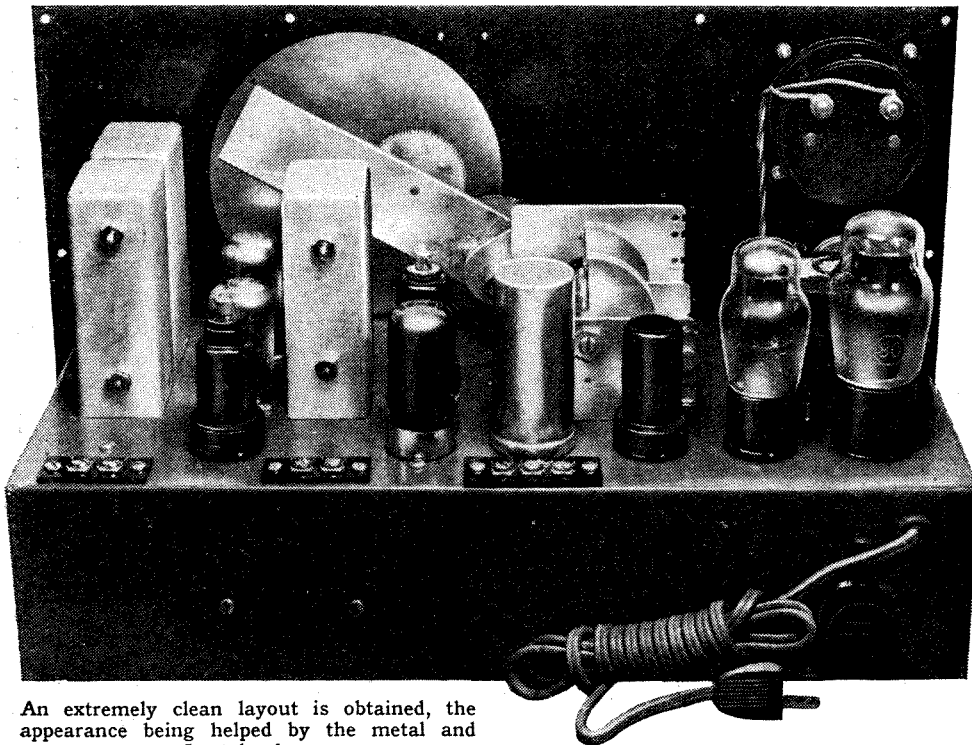

An extremely clean layout is obtained, the appearance being helped by the metal and Loctal valves.

allow noise to be held down to the signal level—and in operation this sounds as if the noise had been completely eliminated. This whole operation could have been made automatic, but this is undesirable because then the system becomes such a perfect "hole-puncher" that a local noise will completely shut off reception until it ceases. This is the true measure of the effectiveness of any of the so-called "hole-punching" noise-eliminating systems.

A headphone jack is included in the 6B8 anode circuit after the tone and volume controls. This provides a nice audio discrimination against heavy low-frequency noise, for the high pentode anode resistance in effect "tunes" the phones so that they do not respond to the low tones, which are useless for either CW or intelligible phone reception. They are there on the speaker, however, which is where they belong for the reception of music. The 7C5 audio stage is so conventional as not to deserve special comment.

The power supply is worthy of notice, not because it uses a power transformer, large high-inductance filter choke and plenty of 450-volt can-sealed dry electrolytic filter capacity, but because it allows either battery or AC operation of the same receiver. An 8-pin socket with dummy plug strapped across for AC operation allows the power circuits to be broken by pulling out the dummy plug. This opens the rectifier + HT lead and the heater circuit, to which batteries, or a 6-volt bat-

one of the writer's recently invented "Diversity Couplers," the addition of which turns the "Silver-Super" into a full-fledged anti-fading dual diversity receiver.

Upon the premise that no communica-

Dry-Cell LT in U.S.A.

FROM OUR NEW YORK CORRESPONDENT

THE dry-cell valve has had a hectic life in America. Originally there was a contest between a Westinghouse triode and a General Electric triode. The former had a coated filament which ran at 0.25 ampere, 1.1 volts; the latter used a thoriated filament at 0.06 ampere, 3.3 volts. Westinghouse believed in connecting dry cells in parallel, General Electric preferred them in series—in either case the filaments gave up the ghost when the rheostat was turned up too far. The 3.3-volt tube begat a fragile RF tetrode; the 1.1-volt tube had no offspring.

We went next to "air" cells and 2-volt tubes, mostly of the 0.06-ampere sort, including a pentagrid converter whose oscillator section rebelled at the notion of working on 0.12 watt of filament power. This tube was accordingly made to go by adding another triode externally, causing one engineer to refer to it as the "tube with the outboard mutual conductance." This and similar incidents caused the 2-volt series to diverge until there are 0.06,

0.12 and 0.24-ampere filaments. If always turned on by rheostat instead of switch, and that under the supervision of a dependable voltmeter, these tubes do very well indeed. In honour of long service they were recently renamed. The little "30" triode is now the "1H4-G" and so on down the line. This line, incidentally, includes a general purpose triode, an RF tetrode, sharp and remote cut-off RF pentodes, several pentagrid converters, a diode-triode, a diode-pentode, several loud speaker pentodes, single and double Class "B" loud speaker triodes and even a low-mu loud speaker triode. We had thought the matter settled.

Now we have a 1.4-volt series of dry-cell tubes to be fed from a single cell without the use of a regulating rheostat of any sort.

These valves are in tubular glass bulbs with octal bases, and comprise RF and AF pentodes, a pentagrid frequency-changer and a diode-triode. Filament current is 0.05 or 0.1 amp.

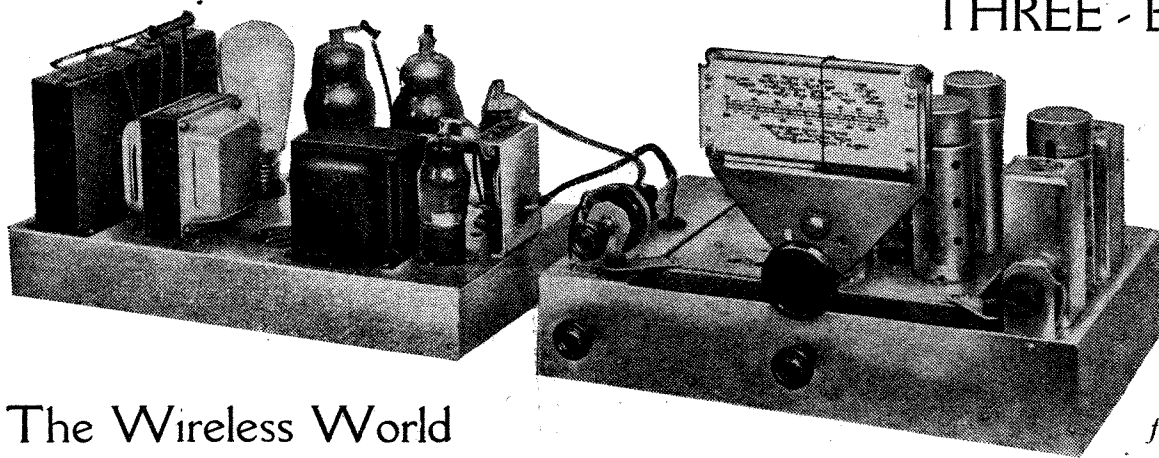

THREE - BAND RECEIVER FOR THE DC QUALITY AMPLIFIER

The Wireless World

DC Mains Super

AMONG the series of articles on receiver design which appeared last year in *The Wireless World* considerable space was devoted to the design and construction of a high-quality amplifier for DC mains operation.¹ This amplifier has two KT31 valves in push-pull in the output stage; they operate with negative feed-back and deliver an output of 5 watts. The penultimate stage is a triode-connected KTZ63 (or 6J7) operating as a phase-

¹ *The Wireless World*, February 24th, 1938.

splitter, and the first stage is an H63 (or 6F5) amplifier.

The design of DC mains apparatus differs from AC chiefly in the output stage, since the main limitation of the DC supply is its low voltage. The early stages of a receiver differ from AC practice only in that the valve heaters are connected in series instead of in parallel and that a few extra by-pass condensers are necessary. It is, therefore, usually a very simple matter to modify the design of the early part of an AC set for DC operation.

APPARATUS for DC mains operation differs from AC equipment chiefly in the output stage, and the early circuits are always substantially the same. There are, however, minor points of difference which are well brought out in this receiver. It is a superheterodyne designed for use with the DC Quality amplifier.

In response to numerous requests, however, the details of a receiver designed especially for use with the DC Quality Amplifier is given in this article, and it will be instructive to see how closely it follows normal AC practice. A general-purpose receiver has been selected as the example and it covers the usual medium and long wavebands in addition to covering the

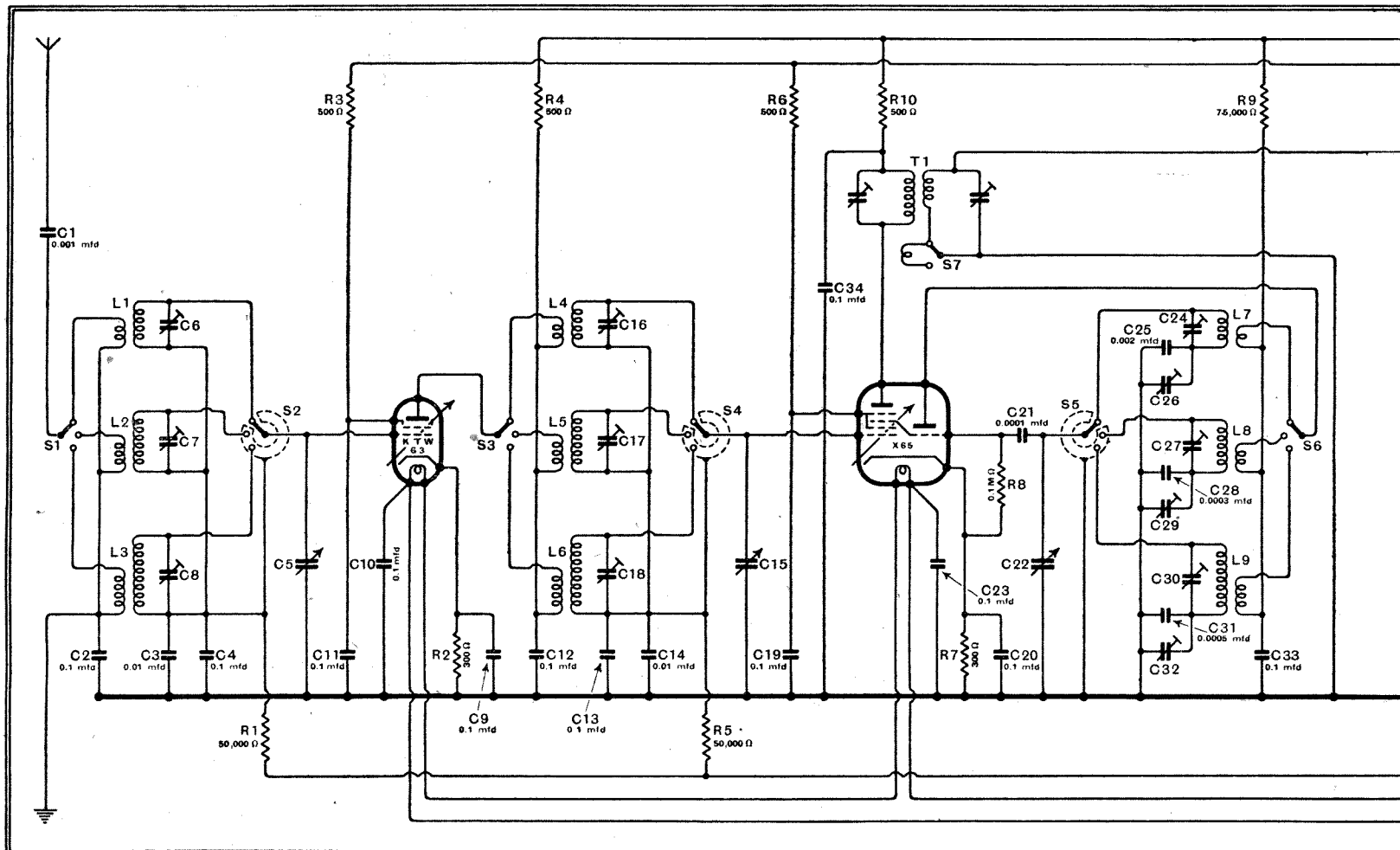

most useful portion of the short waves in one band.

The circuit diagram is shown in Fig. 1, and it will be seen that there is one RF stage, frequency-changer, one IF stage, and a diode detector and AVC source. The output of the detector is taken to the DC Quality Amplifier, from which the power supply is also derived.

The valves used have their heaters connected in series with those of the amplifier, consequently they must consume the same current—0.3 ampere. The heater voltage rating does not matter much, but the lower the voltage chosen the less will be the voltage between heater and cathode of the valves towards the positive end of the chain. This is some slight advantage and we accordingly adopt 6.3-volt valves.

Referring to Fig. 1, the general arrangement of the circuit will be seen to be quite straightforward and conventional. The RF valve is a KTW63 (or 6K7) which is self-biased by the 300-ohm resistance R2 shunted by the 0.1 μ F condenser C9. The screen is fed from the 100-volt line and decoupled by R3 and C11.

The switch S2 selects the appropriate coil—L1, L2, or L3—for the band desired, while S1 changes the aerial connection. Parallel trimmers C6, C7 and C8 are provided and tuning is carried out by the section C5 of the gang condenser. AVC is applied to the valve through the tuning coils, the filter R1 C3 being provided. C3 is given a value of 0.01 μ F for short

waves, but is shunted by the 0.1 μ F condenser C4 to provide a more effective bypass on the longer wavelengths.

Similar circuits are used for the coup-

ling of the anode circuit of the RF stage is obtained with R4 and C12.

The frequency-changer is a triode-hexode—the X65—and AVC is applied to it through the filter R5 C14; as in the case of the RF stage, the 0.01 μ F condenser C14 is shunted by C13 of 0.1 μ F. The screen of the triode-hexode is fed from the 100-volt line and decoupling is provided by R6 and C19. Grid bias is obtained in the usual way from the cathode resistance R7, which is shunted by C20.

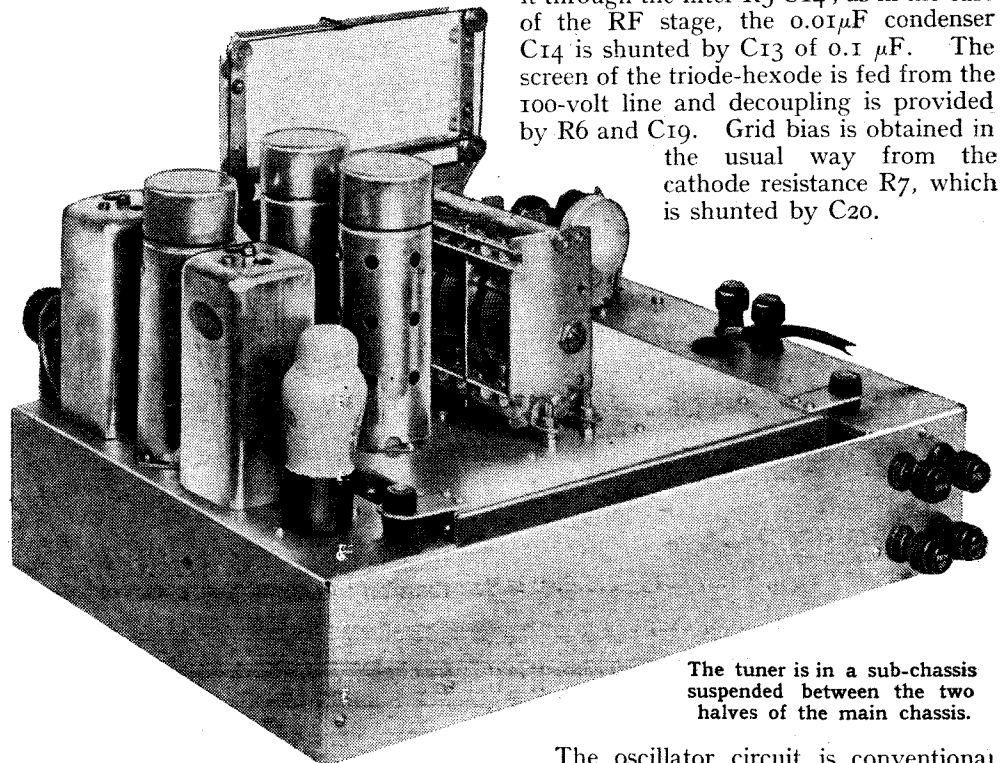

The tuner is in a sub-chassis suspended between the two halves of the main chassis.

ling between the RF and frequency-changer valves, the coils being L4, L5 and L6, with the trimmers C16, C17, C18 and the tuning condenser C15. Decou-

The oscillator circuit is conventional. The parallel trimmers C24, C27 and C30 are provided, as well as adjustable padding condensers on each band. On short waves the padding capacity comprises C25 and C26 in parallel, while for the medium waveband C28 and C29 are effective. On long waves, C31 and C32 are the relevant condensers.

The intermediate frequency is 465 kc/s and the first IF transformer, which couples the FC and IF valves, is of the variable selectivity type. The coil coupling is fixed mechanically. The two main windings provide the normal coupling for high selectivity, but a third winding which is tightly coupled to the primary can be thrown into circuit by S7 to increase the total coupling for low selectivity. This system is very simple and in practice works very well.

The IF stage is another KTW63 (or 6K7), but is not controlled from the AVC system. This is to reduce the possibility of distortion through overloading the IF valve when receiving strong signals.

Following the IF valve comes the detector, for which the D63 (or 6H6) diode is used. The two anodes and cathodes in this are strapped so that the valve operates as a single diode. IF filtering is provided by R14 and C39 and the load resistance is the volume control R18.

The alternating potentials across this resistance constitute the AF output and any desired fraction of them can be taken off through the coupling C43 R19 to the first AF valve in the amplifier. The steady voltage across R18 is used for

Fig. 1. This diagram shows the complete circuit of the receiver portion. Isolating condensers C1, C2, C41 and C42 are connected in the aerial, earth and pick-up leads.

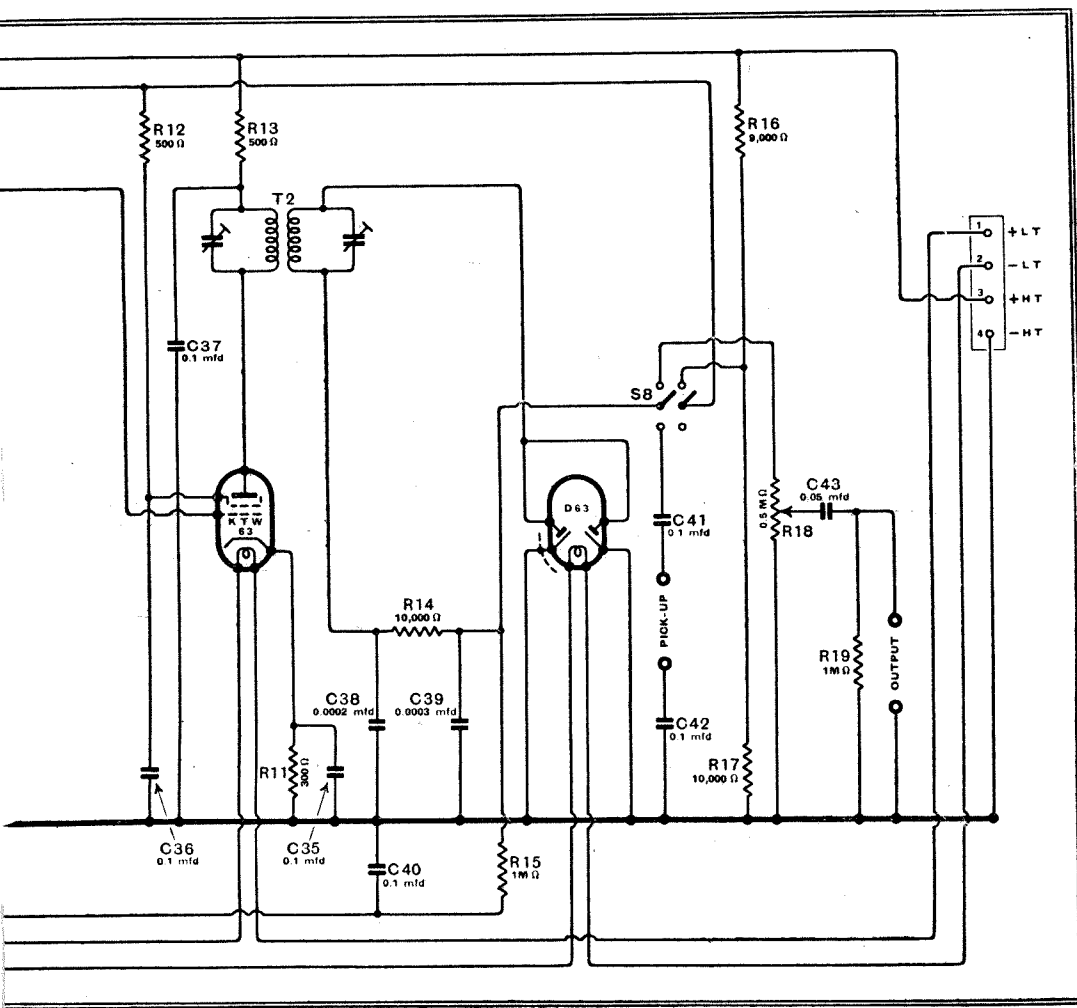

DC Mains Super—

AVC purposes and is taken off through the filter R15 C40, the purpose of which is to remove the AF signal from the AVC line.

The switch S8 is for the change over from radio to gramophone and on the latter breaks the screen supply to the first three valves. The screen supply is taken from the voltage divider R16, R17.

The differences from AC practice, apart from the heater supply, are merely those brought about by the fact that the cir-

LIST OF PARTS

1 Condenser, 3-gang, 0.0005 mfd., C5, C15, C22
Polar C1703

1 Dial, ratios 10:1 and 50:1
Polar "Micro Horizontal Drive"

9 Trimmers, 30-60 mmfds., C6, C7, C8, C16,
C17, C18, C24, C27, C30

1 Trimmer, 3,000 mmfds., C26
Bulgin SW122

1 Double Trimmer, 150-550 mmfds., C29, C32
Polar 55

1 Set of Coils, PA1, PA2, PA3, PHF1, PHF2,
PHF3, PO1, PO2, PO3
Wearite

Fixed Condensers:

1 0.0001 mfd., mica, C21 T.C.C. "M"
1 0.0002 mfd., mica, C38 T.C.C. "M"
2 0.0003 mfd., mica, C28, C39

1 0.0005 mfd., mica, C31 T.C.C. "M"
1 0.001 mfd., mica, C1 T.C.C. "M"

1 0.002 mfd., mica, C25 T.C.C. "M"
2 0.01 mfd., mica, C3, C14 T.C.C. "M"

1 0.05 mfd., tubular, C43 T.C.C. 341

*18 0.1 mfd., tubular, C2, C4, C9, C10,
C11, C12, C13, C19, C20, C23, C33,
C34, C35, C36, C37, C40, C41, C42
T.C.C. 341

Resistances:

3 300 ohms, ½ watt, R2, R7, R11
Dubilier F½

6 500 ohms, ½ watt, R3, R4, R6, R10,
R12, R13
Dubilier F½

1 10,000 ohms, ½ watt, R14
Dubilier F½

2 50,000 ohms, ½ watt, R1, R5
Dubilier F½

1 75,000 ohms, ½ watt, R9
Dubilier F½

1 100,000 ohms, ½ watt, R8
Dubilier F½

2 1 megohm, ½ watt, R15, R19
Dubilier F½

1 9,000 ohms, 3 watts, R16
Dubilier F3

1 10,000 ohms, 2 watts, R17
Dubilier F2

*1 Volume control, 0.25 megohm, tapered, R 18
Reliance "SG"

4 Valve holders, octal type
Clix X218

1 IF transformer, variable selectivity, 465 kc/s
T1
Varley BP124

1 IF transformer, 465 kc/s, T2
Varley BP122

6 Terminals, ebonite shrouded, A, E, PU (2),
Output (2)
Belling-Lee "B"

1 Connector, 4-way
Bryce 5C2

1 Cable, 4-way
Goltone R36/4MR

1 Switch, rotary type, SPDT, S7
Bulgin S92

1 Switch, rotary type, DPDT, S8
Bulgin S114

1 Switch, assembly
Peto-Scott 632FE

comprising: 3 switches, 3-way, SP, 3
switches, 3-way, SP with earthing plates,
locator and 8-inch rod, S1, S2, S3, S4, S5,
S6.

1 Length screened sleeving
Goltone

3 Valve screens, octal type
Peto-Scott

1 Shaft coupler, ¼-inch
Bulgin 2005

3 Grid clips, octal type
Bulgin P96

Tuner Chassis
Peto-Scott

Receiver Chassis, with brackets
Peto-Scott

Miscellaneous:
8 lengths systoflex, 3 ozs. No. 20 tinned
copper wire. Screws: 5 doz. 6BA ¼in.
r/hd., 2 doz. 4BA ¾in. r/hd., all with
nuts and washers; 1 doz. extra 4BA
nuts for mounting switches.

Valves:
2 KTW63, 1 X65, 1 D63
Osram

*Two 0.1 mfd. condensers and the volume
control can be transferred to the receiver from
the DC Quality Amplifier.

uits are not insulated from the mains. It must never be forgotten that with a DC mains set the circuits are inevitably in direct connection with the supply mains.

It is, therefore, necessary to insert the condensers C1 and C2 in the aerial and earth leads to prevent short-circuiting the mains. It is also advisable similarly to insulate the pick-up, and this is done by C41 and C42.

The heaters are connected in series, the detector being at the negative end of the chain, and by-pass condensers C10 and C23 are joined to chassis from the heaters of the RF and FC valves in order to prevent any RF voltages from being developed on these heaters. Such voltages would be likely to cause modulation hum.

Certain minor changes are necessary in the amplifier in order that the receiver may be used with it. Actually, C1, C2 and R1 in the amplifier are removed and transferred to the receiver, where they become C41, C42, and R18. This is done as it is more convenient to have the volume control on the receiver chassis than on the amplifier.

The grid of the H63 is taken straight to one input terminal and the other is joined to chassis. A 4-way connection block is fitted and two of its terminals taken to - and +HT, while the other two are used for the heater supply. The heater lead between the H63 and the KTZ63 is cut and the two ends taken to the terminal block. No other change is needed, for the barretter is still capable of controlling the additional valves.

(To be concluded.)

PROBLEM CORNER-20

An extract from Henry Farrad's correspondence, published to give readers an opportunity of testing their own powers of deduction:—

All Hallows School,
Berkhamsted.

Dear Henry,

I have been making up a gramophone turntable and control panel for a show we are doing here, and thought I would paint stroboscope stripes round the turntable, like the B.B.C., for keeping the speed right. But I don't seem to be able to get the thing to work at all as it should. Can you see what's wrong (you always can!). I've been over it heaps of times. The proper speed is 78 r.p.m. and as the mains frequency is 50 a second, and therefore 3,000 a minute, there ought to be 3,000/78, or 38½, white stripes around the turntable. Actually, I've put on 38, which ought to be near enough, because it corresponds to 79 r.p.m. But it just doesn't do!

No, our lamps are *not* run off DC! I have good reason to remember that, because old Crabbie gave me one of his sarcastic impots for waving a knife about at table years ago to make sure. He couldn't be made to see that it was in the interests of science. And it is a genuine 50 cycles, because we are on the Grid now.

Yours ever,
Tony.

Why didn't the stroboscope work? Solution on p. 472.

**Television
Programmes**

Sound 41.5 Mc/s

Vision 45 Mc/s

An hour's special film transmission intended for demonstration purposes will be given from 11 a.m. to 12 noon each weekday. The National or Regional programme will be radiated on 41.5 Mc/s from approximately 7.45 to 9 p.m. daily.

THURSDAY, MAY 18th.

3, "The Chance of a Lifetime," a sporting romance by John Pudney. 3.35, British Movietone. 3.45, 243rd edition of Picture Page, introducing scenes from the "Dorchester Floor Show."

8.30, Tennis O.B. from the Empire Pool, Wembley. Donald Budge, Ellsworth Vines, Bill Tilden and Hans Nusslein in singles and doubles. 9, Flotsam and Jetsam in Cabaret. 9.35, Gaumont-British News. 9.45-10.15, 244th edition of Picture Page.

FRIDAY, MAY 19th.

3, O.B. from the Crystal Palace of Veteran Motor Cars. 3.20, Gaumont-British News. 3.30, Cartoon Film. 3.35, "A Game of Cut-Throat," with Leon M. Lion and Waldo Wright.

9, "For those in Peril," a drama of the sea by Edward Poor Montgomery. 9.25, British Movietone. 9.35, "Smiling at Grief," a play by Walter Hudd. 10, Cartoon Film. 10.5, "Birds"—Film. 10.15-10.40, "The Lover," a play by C. Martinez Sierra.

SATURDAY, MAY 20th.

2.50, Motor Racing O.B. from Crystal Palace. 3.5, Scenes from the Grosvenor House Cabaret. 3.25-4.35, Motor Racing O.B. continued.

9, Adelaide Hall in "Dark Sophistication," a Coloured Cabaret from the Old Florida Club. 9.30, Tennis O.B. from Wembley (as on Thursday at 8.30 p.m.). 10-10.35, "The Chance of a Lifetime" (as on Thursday at 3 p.m.).

SUNDAY, MAY 21st.

3, Music Makers. 3.10, "London Wakes Up"—Film. 3.30, "The Deacon and the Jewess," a play by H. F. Rubinstein.

8.50, News. 9.5, Mendelssohn's Violin Concerto in E Minor played by Szigeti with the B.B.C. Television Orchestra. 9.30, "The Plough that Broke the Plain"—Film. 10-10.40, "Blind Man's Buffet," a Food Bee conducted by Marcel Boulestin. The blind-folded victims will endeavour to name the edibles which are placed in their mouths.

MONDAY, MAY 22nd.

3-4.25, Sybil Thorndike in "Sun Up," the play by Lula Vollmer.

9, John Carr's Jacquard Puppets. 9.10, "Derby Secrets"—Film. 9.20, "Lonesome Like," a play by Harold Brighouse. 9.50, Gaumont-British News. 10-10.30, The Vic-Wells Ballet in Act III of the "Sleeping Princess."

TUESDAY, MAY 23rd.

3, "For Those in Peril" (as on Friday at 9 p.m.). 3.25, Gaumont-British News. 3.30, Derby Pre-View; O.B. from Epsom Downs. 3.35-4.10, "The Lover" (as on Friday at 10.15 p.m.).

9, "Intimate Cabaret." 9.15-10.30, Boxing O.B. in which it is hoped to televise the Harvey-Farr fight.

WEDNESDAY, MAY 24th.

2.30, The Derby. O.B. from Epsom of the 156th renewal of the Derby Stakes. 3.10, Naughton Wayne in Cabaret, with Billy Costello (Popeye the Sailor). 3.40, Cartoon Film. 3.45, Vanity Fair—modern dress design.

9-10.30, D. A. Clarke-Smith in "The Great Adventure" by Arnold Bennett.

Cathode-Ray Amplifier Tester

A COMPACT PORTABLE INSTRUMENT FOR DIAGNOSING AMPLITUDE DISTORTION

By C. B. GUEST

DEVELOPED primarily for testing cinema amplifiers, this instrument provides the means of tracing faults by inspection of a pattern and with the minimum of preliminary adjustment.

THE testing of a faulty amplifier, the fault being, say, in the nature of slight distortion, has always been troublesome by meter methods. A meter in the anode circuit of the power stage is useful in indicating overloading, but is of very doubtful value in locating the source of the distortion

can be examined. Needless to say, slight departures from the proper waveform cannot be determined without a reference wave superimposed on the tested wave, an obviously difficult thing to do. The impracticability of determining small amounts of distortion in the waveform of music and speech will need no explanation to those who have listened to a note while comparing its trace on the CR tube.

The equipment to be described has the advantage of being independent of waveform and giving a direct indication of the linearity or otherwise of the input-output characteristic throughout the whole of a cycle. The principle on which this works is dependent upon two frequencies, differing by a ratio of at least 60 to 1, applied to the amplifier under test. The low frequency, say 50 c/s, is of comparatively large amplitude, the high frequency, say 3,000 c/s, being small relative to the low frequency. The high frequency is superimposed on the low frequency as in Fig. 1.

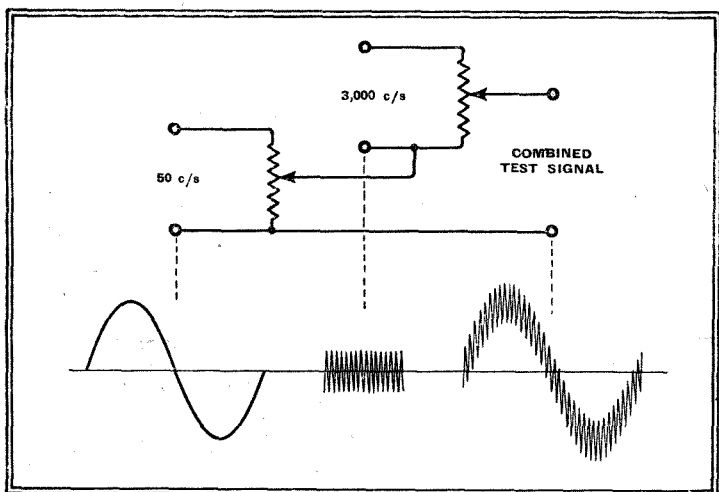

Fig. 1.—The test signal consists of a 3,000-cycle note impressed on a 50-cycle wave.

which is causing the change of current. For instance, supposing our amplifier has a valve which runs into grid current long before it is entitled to do so. How are we to prove it? Then again, there is parasitic oscillation which may occur for only a fraction of the cycle of operations. The list of possible unknowns is endless, and they often require a considerable amount of mental juggling to track to their lair.

Need for Simplicity

Without a doubt the most useful tool available both for research and the servicing of amplifiers is the cathode-ray tube, but conventional circuit arrangements, excellent as they are for use in the laboratory or on the service bench, do not always meet the requirements of portability demanded for outdoor work. Now most cathode-ray tubes need a minimum input of about 30 volts to give even a small image, and it is not easy to build a really light portable test equipment of straight-line characteristics. Then there is usually a time base to adjust before a waveform passing through the amplifier

plied to the amplifier under test. The low frequency, say 50 c/s, is of comparatively large amplitude, the high frequency, say 3,000 c/s, being small relative to the low frequency. The high frequency is superimposed on the low frequency as in Fig. 1. In carrying out a test on an amplifier the amplitude of the test signal is increased until the full working range of the valves is covered. Since amplitude distortion, with which we are most concerned, is merely a departure from a straight line, or change in slope of a line, then at the point of maximum positive sweep on a valve or amplifier with a curved characteristic the amplification of the superimposed high frequency will be



greater than that at the point of maximum negative sweep, giving an output waveform resembling Fig. 2 (a). The next step is to filter out the low frequency, leaving only the high-frequency component, Fig. 2 (b), to be passed on to the horizontal sweep of the cathode-ray tube, the vertical sweep of which is obtained from the same source as the low-frequency sweep to the amplifier, in our case the 50 c/s mains supply.

It will be noted that the success of this system is dependent upon the smallness of the amplitude of the high-frequency sweep

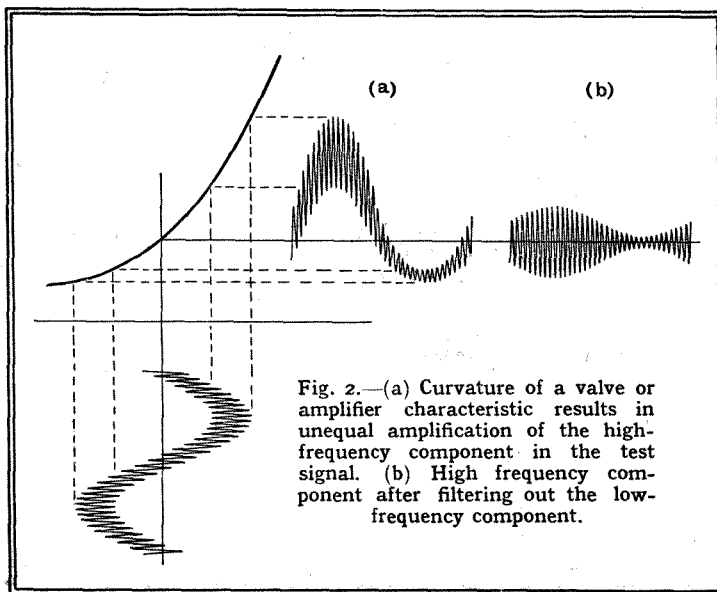

Fig. 2.—(a) Curvature of a valve or amplifier characteristic results in unequal amplification of the high-frequency component in the test signal. (b) High frequency component after filtering out the low-frequency component.

Cathode-Ray Amplifier Tester—to the amplifier under test. The reason for the 60:1 frequency ratio will also be apparent, for this has the effect of dividing the cathode-ray vertical sweep into 60 different parts, each giving a measure of the slope at its own point.

A study of the few examples given in

equipment is the RCA A13 which, although small, has been entirely satisfactory. The image is magnified by a lens mounted on the front of the panel, and not the slightest difficulty has been experienced in viewing the image. It has the further advantage of a built-in metal shield, which is of importance in portable

by-pass the high frequency component. The oscillator valve is one half of a 6A6, the other half being used for the horizontal sweep amplifier. It should be noted that small amplitude distortion of the sweep amplifier is not of great importance, since we are utilising only the outline drawn by the sum of the peaks of the high-frequency sweep.

The mains transformer is wound with No. 42 SWG enamelled wire, which makes a very compact transformer, but it is advisable to use a somewhat heavier gauge of wire. The rectifying valve is a 1-V half-wave, and with the tiny 15-henry choke and 8 + 8-mfd. dry electrolytic smoothing condensers produces about 280 volts HT. No tapping is provided on the mains side of the transformer, and the equipment appears to function happily on anything between 220/260 volts.

Hints on Operation

A point of considerable importance centres around the high-pass filter input to the sweep-amplifying valve. This is series tuned, and the input load is therefore approximately that of the resistance of the coil, which is but a few hundred ohms. If the test is applied to a high-impedance circuit then due regard must be paid to this load. However, in most cases it will only be necessary to insert a resistance in series with the input to the filter of 5,000 ohms or so. In the case of individual valve tests, the high-frequency amplitude is so small that the low load is no disadvantage. A switch is provided which opens the filter circuit when this is not required.

In conclusion, it may be pointed out that, although the primary duty of the equipment is the locating of audio amplifier troubles, its usefulness does not terminate here. Numerous other appli-

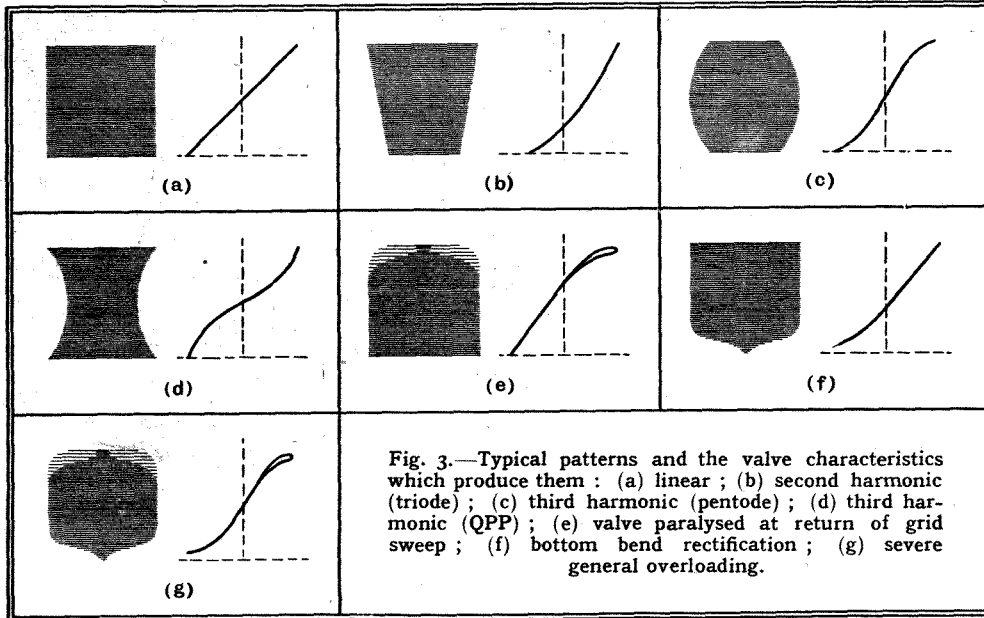

Fig. 3 will give a working idea of the effects produced by different curves. Weird and wonderful are some of the patterns produced by gross overloading, and a lot may be learnt about effects which may never have been expected. One point worth noting is that if one both listens to the sound and looks at the picture, then in every case it will be found that the picture indicates distortion long before it can be detected by ear.

The cathode-ray tube used in this

equipment, and is modest in its voltage requirements.

The high-frequency oscillator is of the usual type with the coils in a metal case. The secondary of the oscillator is stepped down in a ratio of 10:1, and is in series with an 0.05-mfd. condenser and 5,000-ohm potentiometer. The condenser is to prevent the low frequency from circulating in the oscillator coils and modulating it. Likewise a 0.05-mfd. condenser is fixed across the low-frequency potentiometer to

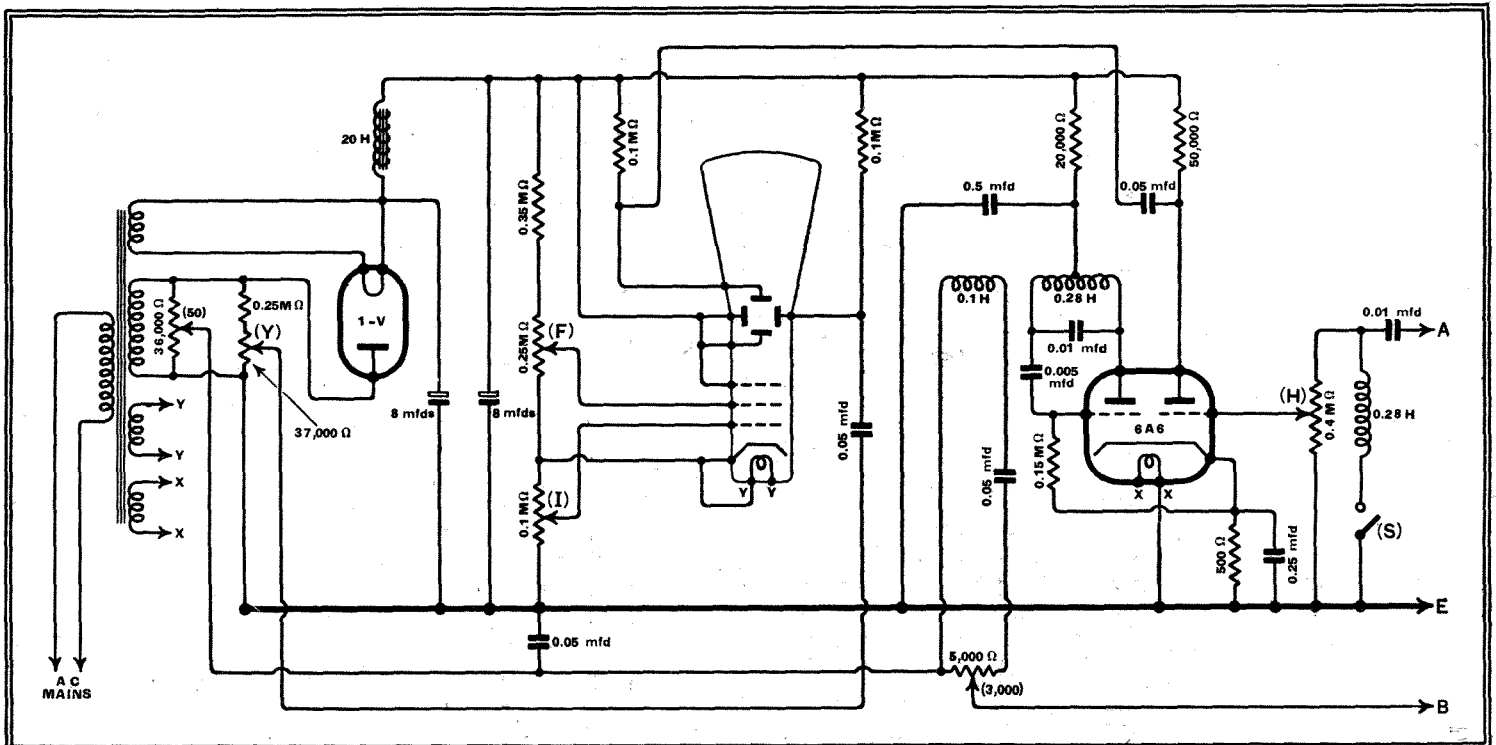
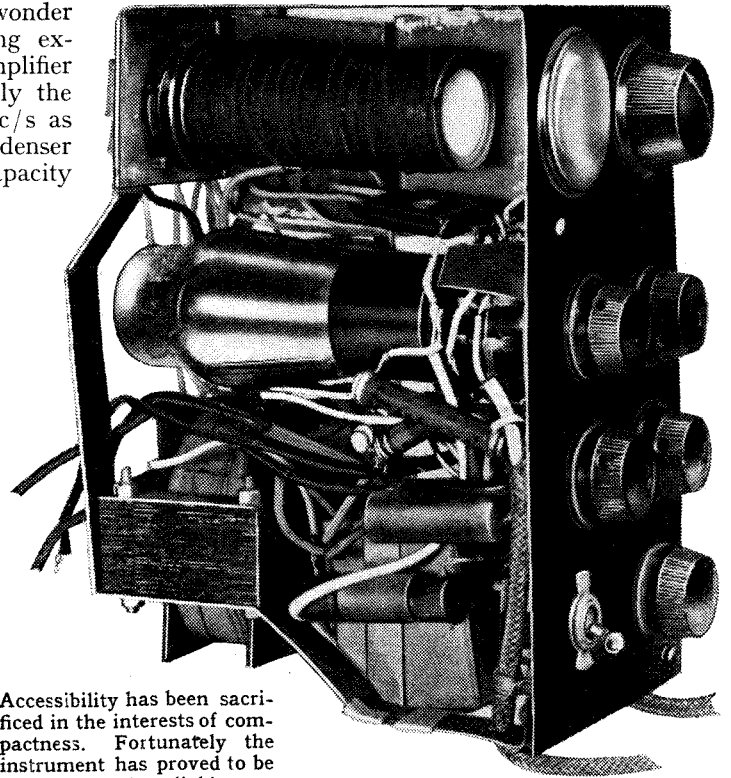

Fig. 4.—Circuit diagram of the portable cathode-ray amplifier tester. Lettering in brackets refers to the controls shown in Fig. 5.

Cathode-Ray Amplifier Tester—
 cations are possible, for instance, inter-
 valve and output transformers may be
 examined provided that due consideration
 be given to the value of the primary cur-
 rent and voltage required to load the
 transformer under test, which may easily

experimenter to "wonder
 why." One interesting exper-
 iment on a valve amplifier
 is to filter out not only the
 50 c/s but the 3,000 c/s as
 well, by fitting a condenser
 of about 0.001-mfd. capacity



Accessibility has been sacri-
 ficed in the interests of comp-
 actness. Fortunately the
 instrument has proved to be
 completely reliable.

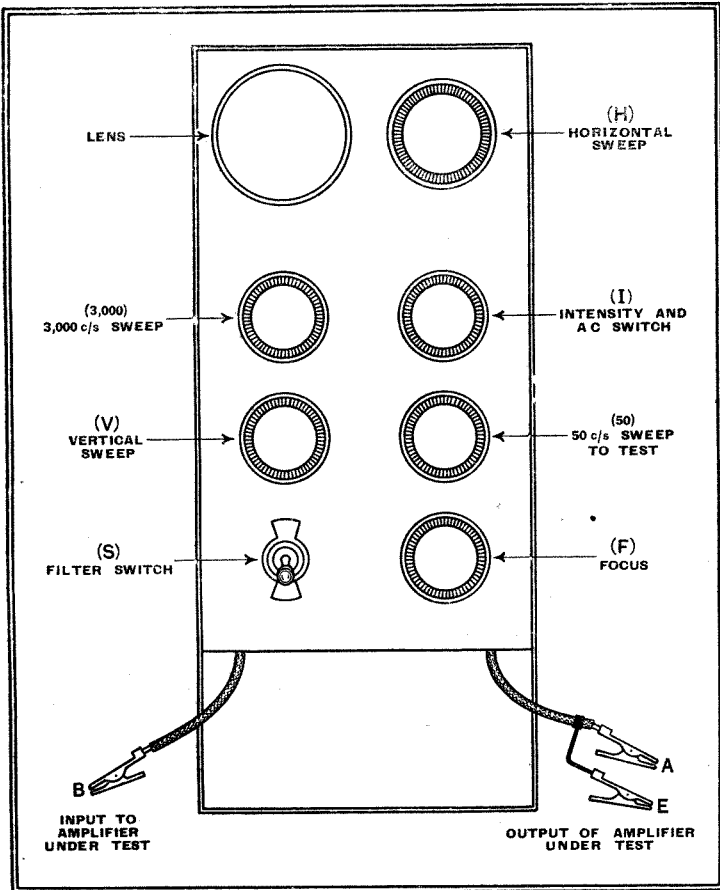

Fig. 5.—The arrangement of the controls on the front panel.

exceed the rating of the midget mains
 transformer fitted to the equipment.
 However, if tests of this kind are contem-
 plated, then a much
 larger or a separate
 50-cycle sweep trans-
 former is desirable.
 Under normal work-
 ing conditions out-
 put transformers are,
 of course, tested in
 conjunction with the
 valve or valves to
 which they are con-
 nected, preferably on
 a resistance output
 load which is, unlike
 the loud speaker,
 constant at all audio
 frequencies. Under
 laboratory conditions
 of test some weird
 and wonderful pat-
 terns often appear
 which challenge ana-
 lysis and offer ample
 opportunity for the

in some cases may indicate, at various
 points, a failure to amplify the harmonics
 at all.

in series with the in-
 put to the cathode-
 ray internal amplifier
 filter, which now
 mainly passes on the
 third and higher har-
 monics of the 3,000-
 c/s frequency. It is
 reasonable to expect
 that the picture
 drawn will resemble
 the parent 3,000-c/s
 picture, but often it
 is much different and

Much may be learnt about individual
 valves which can be both enlightening and
 instructive.

Finally, to the writer, a cinema en-
 gineer, speed in locating trouble is often
 a vital factor, and the test equipment
 described was originally designed for this
 purpose; it has proved its value where
 other methods would have been unsatis-
 factory.

News from the Clubs

Golders Green and Hendon Radio Scientific Society

Headquarters: Regal Cinema, Finchley Road, Hampstead, London, N.W.2.

Hon. Sec.: Lt.-Col. H. Ashley Scarlett, 60, Pattison Road, Hampstead, London, N.W.2.

Mr. D. N. Corfield recently lectured on "The Application of the Cathode-Ray Tube to Measurement." Waveform comparison and analysis were demonstrated. The lecturer also demonstrated an electronic switch which enabled the input and output waveforms to be superimposed.

The 80-metre DF competition organised by the Society will take place near St. Albans on May 21st. All interested are invited to write to the Hon. Secretary.

Tufnell Park Radio Club

Headquarters: 33, Pemberton Terrace, Tufnell Park, London, N.19.

Meetings: Tuesdays and Fridays at 8 p.m.

Hon. Sec.: Mr. J. G. Wright, 78, Gladsmuir Road, Highgate, London, N.19.

On May 5th Mr. King gave a lecture and demonstration of a well-known make of commercial superhet. On May 9th another member demonstrated an ultra-short wave converter.

The following programme of Friday-evening talks by members has been arranged. In each case the talk will last from 9.30 to 10.15 p.m.

May 19th.—"Propagation of Wireless Waves."

May 26th.—"Reception of Wireless Waves."

June 2nd.—"Short-Wave and Anti-Interference Aerials."

June 9th.—"The Amateur Bands."

June 16th.—"Valves for Short-Wave Working."

June 23rd.—"The Interpretation of Meter Readings."

June 30th.—"Hints and Tips on Learning Morse."

Sale and District Radio Society

Headquarters: St. Mary's School, Barker's Lane, Sale, Lancs.

Meetings: Thursday evenings.

Hon. Sec.: Mr. S. C. O. Allen, 31, Ennerdale Drive, Ashton-on-Mersey, Lancs.

A series of lectures has been arranged on the fundamental principles of electricity and magnetism with reference to radio communication. Two members of the Society hold full transmitting licences and three have artificial aerial licences.

This club is additional to those given in the "Directory of Wireless Societies," published in *The Wireless World* of April 6th.

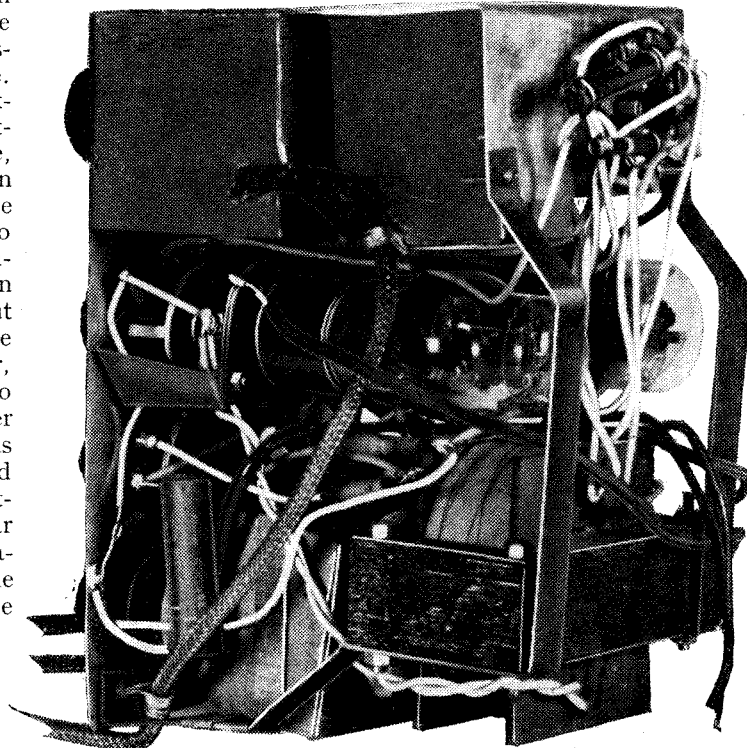

Rear view of chassis. The mains transformer is unusually small and is wound with 42SWG wire.

Letters to the Editor

The Editor does not necessarily endorse the opinions of his correspondents

Talkie Quality

I AM afraid I do not agree with "Dial-list's" Swindon correspondent on what he calls, in your issue of April 27th, the "villainous quality" of the sound reproduction in cinemas.

As an ex-sound and maintenance talkie engineer, I doubt very much whether the control of sound in an auditorium is left to the already overworked projectionist (here I agree with him)—particularly in large cinemas.

Surely there still remains the automatic volume control system whereby the manager, assistant manager, or someone responsible can control the volume from the auditorium.

In my experience, most cinemas found time to run through the feature films and noted the bad spots. Scratches on a film cannot be avoided, but oil is another matter, and this shows the projectionist does not attend to his apparatus properly.

I agree that the projectionist cannot judge the correct amount of volume needed for the auditorium by the sound in the "box," but a cinema properly run should have someone in the auditorium to check the volume.

In conclusion, I maintain that the average quality of sound reproduction today in at least first-class cinemas is of a high standard, and "villainous quality" is an unheard-of thing.

M. L. DIXON.

London, W.C.

Reproduction Level and "Scale Distortion": A Reply from America

WE read the letter of Mr. J. R. Hughes relative to the article on our receiver, printed in *The Wireless World* of April 13, 1939, with a great deal of satisfaction. It is not too often that a correspondent grasps the fundamentals behind a design as thoroughly as Mr. Hughes has. I think that we see eye to eye with one another technically, and I will even go so far with him, from a practical point of view, as to agree that reproduction at the original level, all other things being as near perfection as is possible, represents higher fidelity than reproduction at any other level. Beyond this, however, we differ, and our absolute conviction of the impracticality of his stand is the basis for our satisfaction in his letter, for if he is wrong here he has only proved our point.

Our contention is that the average music-lover in this country would be promptly dispossessed by his landlord or hailed into court by his neighbours if he persisted in operating his reproducer at concert volume. This situation is created by a combination of circumstances such as crowded living conditions, poor building construction in so far as sound-proofing goes, a lack of musical appreciation on the part of the average man, or at least a determination on his part to select his own music and the time when he will hear it. This situation, although perhaps regrettable in part, is actual and must be faced, we think, not only by the average American, but also by a great many Englishmen.

We have solved this problem to the extent of making it possible for the listener

to hear the deep bass and high overtones of music in the proper proportions to the middle register at no matter what loudness he must or wishes to listen. As this indicates, our set, having more power output than the average, is capable of reproducing concert volume in the average living-room if the user wants it. Further, by adjustment of the controls he may secure compensation not only for the average ear characteristics at the volume level which he selects, but also for individual ear defects, room acoustics, recording or transmission limitations, etc., as well, and arrive at a result which gives him his music the way he wants to hear it, whether that requires a flat curve or any other possible curve lying between the limits shown by the two curves printed in the article.

Relative to how a person will want to hear his or her reproduced music sound, it might be well to point out that the reduction in volume, in a well-designed concert hall, will depend not only on where the person sits, but also on the acoustical time constant of the hall. In any event, it will be small when compared with the reduction usually necessary for reproduction in the home.

For further information we suggest reading an article in the *Atlantic Monthly* for January, 1935, by the well-known composer and director, Leopold Stokowski, entitled "New Vistas in Radio."

In conclusion, let us say that we feel we have designed a radio and gramophone which gives tone balance and high-fidelity reproduction at concert volume as well as the most faithful reproduction at reduced or home level, which is not possible with any other commercial instrument. We believe it represents a great advance in the art.

L. G. PACENT,

H. C. LIKEL,

Pacient Engineering Corporation.

New York, U.S.A.

Single-wire Feeders

I AGREE with Mr. Redfearn's remarks in your issue of April 27th; a twin-wire current-fed aerial is more suitable for the novice. However, my article was not intended to be a discussion on aerials.

I should like to point out at the same time that, although a voltage-fed aerial was shown in Fig. 1, the inscription underneath stated that the aerial could be either an end-fed (voltage-fed) or a Windom, but even when a Windom is used and matched it will radiate harmonics, due to the fact that it acts as a long-wire radiator to these unwanted harmonics.

A. G. CHAMBERS (G5NO).

Coventry.

Condenser Impedance

HAVING carried out experiments on the impedance of condensers at high frequencies, and published some data¹ on the capacity for minimum impedance at any frequency, I was very interested in Mr. F. R. W. Stafford's article on this subject, and welcome his more comprehensive data taking into account leads of various lengths.

¹ *The Wireless World*, September 29th, 1933, and November 20th, 1936, *Radio Laboratory Handbook*, p. 321.

To make this information suitable for the purpose intended (i.e., for design) it is necessary, however, to specify the disposition of the leads. It would seem to be the natural thing to run them as straight as possible, joining the points between which the approximation to zero impedance is desired. Calculating the inductance at 100 Mc/s of straight lengths of 20 SWG wire of double the lengths given in Mr. Stafford's Fig. 5 (which refers to each lead), the capacity required for resonance is far less (e.g., for 8 cm. leads at 100 Mc/s, 14 μ F instead of 100 μ F), and I can only conclude that the inductance was calculated for parallel leads in Mr. Stafford's data, but as the distance apart is not specified I cannot confirm this.

My own data excluded external leads, and referred only to the inductance of the condenser itself, which I had found by experiment to be approximately equal to that of a straight piece of wire joining its terminals. Assuming these to be in. apart, the optimum capacity at 100 Mc/s is 100 μ F, whereas the equivalent in Mr. Stafford's data (a pair of leads each 1.25 cm. long) is 1,000 μ F.

Although it is impossible to cover all possible wiring conditions exactly by simple data sheets, I feel that if supplemented by more definite information on the conditions assumed, Mr. Stafford's graph would provide a higher order of approximation.

Bromley, Kent. M. G. SCROGGIE.

Proposed New Amateur Code

WITH reference to the announcement on page 436 of your last issue, we feel it desirable to point out in fairness to your readers who may be members of the Radio Society of Great Britain that the proposed new Code was first submitted to the Society as recently as May 4th last. On receipt, the author was informed that the Code would be placed before the Council for consideration at its meeting on May 9th.

The Council agreed, in view of its interest, to study it individually prior to the next meeting, which will be held early in June.

J. CLARRICATS,

London, S.W.1. Secretary-Editor,
The Radio Society of Great Britain.

Inert Cells

MY observations with respect to inert cells, published in your issue of April 27th, have resulted in my receiving a "purely friendly protest" from Mr. R. A. Gascoine, who suggests that my memory is at fault concerning the 1916 experiments. He claims that the apparatus was his and the results obtained should be credited to him.

In lodging his claim he refers to the matter as a "trivial affair," but, all the same, the last thing I desire to do is to assume as my own something to which others believe me to be not entitled.

From long association with Mr. Gascoine I have no doubt of his sincerity in the matter and crave his indulgence, as well as that of your readers, for what appears to have been a misstatement of fact.

STANLEY G. RATTEE.

London, E.C.4.

NEWS OF THE WEEK

MARCONI RESEARCH

Features of the Company's Annual Report

IN the course of his report at the annual meeting of the Marconi Wireless Telegraph Company, Mr. H. A. White, the chairman, stressed the importance of research, which has been the life-blood of the Company whose future, he said, depended primarily on the continuation and expansion of the work.

The erection of a new main building for research laboratories, and the enlargement of the Marconi College at Chelmsford, where students of nineteen nationalities were at present working, were the joint cause for a major part of the increase in the value of the Company's fixed assets, which had risen from £297,589 at the end of 1935 to £549,420 at the present time.

Opportunities for Research

"As a general rule," said Mr. White, "the student coming to us without actual research experience does not become a productive member of the staff until he has completed at least two years of service after the six months' probation period at the Marconi College."

"There is no foundation," he continued, "for the assertion frequently heard in these days that there is nothing more to discover in the field of high-frequency engineering for wireless purposes. There are, on the contrary, immense opportunities for research, including, for instance, the investigation of the lowest band of ultra-short waves from 1 to 3 metres, and of micro waves measured in centimetres and perhaps ultimately in millimetres."

NAVIGATION MADE TOO EASY

Limiting Use of Wireless in Ocean Racing Yachts

IN order not to place an undue handicap upon racing-yacht owners who are unable for financial reasons to install the expensive transmitting equipment which gives their more wealthy opponents an advantage over them, the Royal Ocean Racing Club has issued a special regulation. It prohibits the use of wireless for the transmission of signals or messages in order to obtain assistance in determining position or obtaining weather reports or forecasts.

It would seem that the rule also tends to maintain the standard of skill required in navigation. Although yachts engaged in ocean racing will no longer be allowed to ascertain their position by calling two coast stations and obtaining cross bearings, the use of wireless for the

Certain observations of Mr. White's with regard to exports are of particular interest. He stated that during the last twelve years more than eighty per cent. of the Company's sales have been to foreign countries. This proportion has decreased considerably during the last year or two, but the home market does not in normal times offer sufficient scope, so that it is of vital importance to the company to maintain its export business.

Recent Marconi Inventions

During the year under review, 274 British patent applications and 874 applications in oversea countries were filed in addition to a large number of applications in other countries by subsidiary and associated concerns. The total number of Marconi patents now in force at home and abroad approximates to 6,500.

Television Mass Production

"The Marconi-E.M.I. Television Company was formed in 1934 by Electric and Musical Industries, Limited, and ourselves," said Mr. White, "on a fifty-fifty basis for the production and sale of television transmitters and of apparatus accessory to them and, as was to be expected, it has not yet earned any profits in this pioneering activity."

He wound up this part of his report by stating that the sale of television receivers was rising in the London area with such rapidity that radio manufacturers are preparing for mass production in the very near future.

reception of direction finding and meteorological signals is unaffected by this new rule.

BRITISH TELEVISION IN U.S.A.

ENGINEERS are installing Baird big-screen television apparatus in several famous Broadway cinemas in New York. The entire equipment has been shipped from England and will be placed in operation as soon as the installation is completed. The National Broadcasting Company will seize any opportunities to televise the King and Queen during their visit to New York, and hundreds of people will appropriately be able to see Their Majesties by means of British receivers if present plans materialise.

AMERICAN TELEVISION

Transmitting Frequencies

ALTHOUGH nineteen bands for American television stations are provided in the new assignments by the Federal Communications Commission few of them are at present in use or, for that matter, likely to be in the near future.

None of the receivers at present on the American market provides for more than the first five television bands in the accompanying table of allocations; they are those from 44-90 Mc/s. The present position, therefore, regarding the bands between 96 and 108 Mc/s is somewhat indefinite, and there is apprehension as to their possible usefulness for transmitting for home reception. The bands from 156 Mc/s have been chosen as the most suitable for relaying transmissions. One of them, for example, will shortly be used for transmission between New York City and Schenectady, about 120 miles away.

American Transmitting Frequencies

Mc/s	44-50	Television
50-56	Television	
56-60	Amateur	
60-66	Government	
66-72	Television	
72-78	Government	
78-84	Television	
84-90	Television	
90-96	Government	
96-102	Television	
102-108	Television	
108-114	Television Relay	
114-120	Government	
120-126	Television Relay	
126-132	Government	
132-138	Television Relay	
138-144	Government	
144-150	Television Relay	
150-156	Government	
156-162	Television Relay	
162-168	Government	
168-174	Television Relay	
174-180	Government	
180-186	Television Relay	
186-192	Government	
192-198	Television Relay	
198-204	Government	
204-210	Television Relay	
210-216	Government	
216-222	Amateur	
222-228	Government	
228-234	Government	
234-240	Television Relay	
240-246	Government	
246-252	Government	
252-258	Television Relay	
258-264	Government	
264-270	Television Relay	
270-276	Government	
276-282	Television Relay	
282-288	Government	

Government assignments are actually slightly narrower to provide guard bands. All television bands accommodate a sound and vision channel.

Some of the receivers provide for reception on two bands only; they are those used by the N.B.C. transmitter, W2XBS, in the Empire State Building, New York City, and the C.B.S. transmitter, W2XAX, a few hundred yards away in the Chrysler Building. The frequencies used by W2XBS are: vision 45.25 Mc/s and sound 49.75 Mc/s. The C.B.S. transmitter, W2XAX, uses 51.25 Mc/s for vision and 55.75 Mc/s for sound.

After a long controversy as to the best method of using the 6-Mc/s bands it has been decided in favour of the normal transmission of sound and the use of a type of semi-single-side-band vision signal. For reasons mainly to do with filtering losses the side-band towards the low-frequency edge of the channel is not attenuated at once, but a relatively sharp cut-off is provided near the edge of the channel, starting about 0.75 Mc/s from the vision carrier.

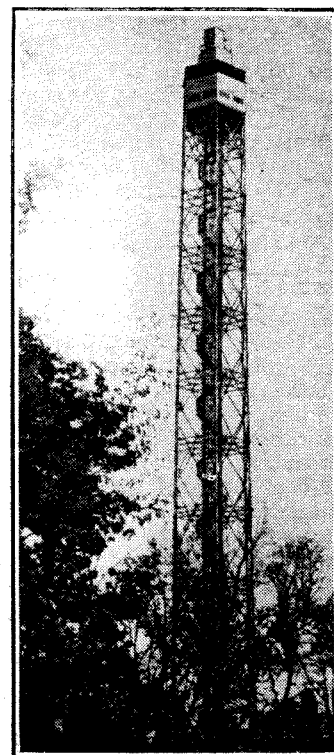

UP ALOFT. The transmitter of the Milan ultra-short-wave station is installed at the top of the Littoria Tower.

ULTRA-SHORT WAVES IN ITALY

ITALY'S second ultra-short-wave transmitter has recently been installed by the E.I.A.R. in Milan, where use has been made of an existing tower, known as the Littoria Tower, in the North Park. The most interesting feature of the station is that the transmitter has been installed in a building erected at the top of the tower. This, of course, avoids the losses encountered when using a long transmission line from the transmitter to the aerial.

The aerial, which consists of six vertical aluminium tubular di-poles of a quarter wavelength, surmounts the transmitter building. The station, which is at present transmitting the second Italian programme from 4 to 6.30 p.m. G.M.T. on 43.79 Mc/s (6.85 metres) with a power of 400 watts, will ultimately be used for television. It is with this in view that the present experimental transmissions are directed.

REAL SERVICE

FOLLOWING the offer of the Rola Company (Aust.) Pty. to repair free of charge loud speakers damaged in the bush fires, the Australian journal *Radio and Electrical Retailer* states that many applications for this service have been received. Although some of the speakers received were but tangled wrecks, in every case Rola was able to effect a repair.

Examination showed that the

News of the Week—

heat in some cases was so great that the brass screws were melted into a shapeless mass. To bring this about, approximately 1,500 degrees Fahrenheit would be necessary, and although steel is supposed to lose its magnetism at 1,000 degrees F. all the permanent magnets still retained their properties.

ARGENTINE'S RADIO PLANS

ELONGATED countries like Norway, Sweden, the Argentine and Chile have tended to build a great number of low-power broadcasting stations in order to cover the country, and to-day the Argentine possesses no fewer than fifty broadcasting stations, about 75 per cent. of which are of purely local importance, half of them being under 10 kW, while 25 per cent. are scarcely 1 kW. Most of them belong to private societies.

Like Sweden, the Argentine, too, is now changing to higher-powered stations. Instead of fifty stations there will probably be thirty-one, six of them being in the capital, Buenos Aires. Four of those in the capital are to have a power of 50 kW and the remaining two 10 kW each. The power of the regional stations will be determined by local conditions and requirements.

Short-wave stations for overseas broadcasting are also envisaged. Revenue would still be sought by sponsored programmes, but all the undertakings would, as far as possible, be united in one national corporation.

THE SCIENCE MUSEUM

IN the annual report of the Advisory Council of the Science Museum, which has just been issued, mention is made of the interesting acquisition of one of the original manuscripts, dated 1888, of Heinrich Hertz, whose work laid the practical foundations of radio communication. This important document, which describes his work on the propagation of electro-magnetic waves, was presented by his widow, Frau Elizabeth Hertz, now resident in England.

The successful television exhibition held in the Museum last year has provided the nucleus of a permanent collection which has been set out in a small gallery adjoining the radio communications section, although it is pointed out that the space is inadequate for this important branch of wireless.

It is recorded that the number of visitors to the Museum in 1938, exclusive of readers in the Science Library, was 1,137,635, which is over 130,000 less than the previous year.

FLYING DOCTOR RADIO SERVICE

THE excellent work that is being carried on by the Flying Doctor Radio Service under the auspices of the Australian Aerial Medical Services, formerly the Australian Inland Mission, is reported by Mr. E. J. T. Moore, who is the official nominee of the I.R.E. (Australia) on the Board of the A.A.M.S.

The main station of the service, situated at Broken Hill, is linked by wireless to eighteen outposts, at each of which the sets are operated by pedal generators. During a recent period of four weeks the Flying Doctor was actually in the air for fifty hours.

SET METERS FOR LISTENER RESEARCH

RADIO set meters are being used to gauge "listener reaction" in America, according to Mr. R. J. E. Silvey, head of the B.B.C. Listener Research Section, who has just completed a tour of the United States.

A meter has been devised which, when fixed to a set, registers the hours during which it has been switched on and the frequencies upon which it has operated.

**FROM ALL
QUARTERS****Civil Defence Research**

DR. E. V. APPLETON, the well-known physicist, who is secretary of the Department of Scientific and Industrial Research, has been appointed chairman of a committee of eminent scientists appointed by the British Government to supervise researches into civil defence measures.

New T.C.C. Director

MR. E. W. DOREY, A.M.I.E.E., who has been associated with the Telegraph Condenser Company for eighteen years, has been appointed a director of the firm. He will be in charge of the general sales organisation.

Television Lectures

A COURSE of four lectures on television is to be given by Mr. H. J. Barton-Chapple at the Polytechnic, 309, Regent Street, London, W.1, on Thursdays from 7.30-9 p.m., commencing on June 8th. The fee for the course is 6s.

The Four Rs

"**C**LEVELAND, Ohio, has a director of education who pins his faith to the 'Four Rs' as the foundation of learning, which he bases on Readin', Ritin', Rithmetic and Radio."—*The Journal of Education*.

Floating Signal School

H.M.S. *Chrysanthemum*, the convoy sloop which is now permanently berthed off the Victoria Embankment, London, ahead of **H.M.S. *President***, will house the signal school of the R.N.V.R.

I.W.T. OFFICERS

THE continued progress of the Institute of Wireless Technology, as manifested by the increase in applications for admission to membership, was stressed at the thirteenth annual general meeting of the Institute held on April 28th, when the following officers were elected for the year 1939-40:

President, Sydney A. Hurren; Hon. Treas., George Lea; Council, Frank Boyce, Horace A. Brooks, B. Tunbridge Hogben, William E. Miller, H. A. G. Howse, Leslie H. Paddle, Gerald P. Sayers and Timothy F. Williams.

It is interesting to note that it will be Mr. Hurren's third year of office as president.

RADIO-CONTROLLED CARS

TWO cars controlled by wireless crashed head-on at the Cowley Works of Morris Motors last week. The collision was staged before the directors and research engineers to test two methods of construction. The cars were started 150 yards apart, and on the first run missed each other. At the second attempt the desired result was achieved. The cars met at 30 miles an hour. One of them was wrecked, but the other, a new model, sustained only superficial damage.

Radio's Part in Jutland Battle

How radio helped both sides in the battle of Jutland will be brought out in a new naval play, "Jutland," by Captain Taprell Dorling, D.S.O., R.N. ("Taff-rail"), to be broadcast on the National wavelengths on June 2nd. Although the radio equipments of both fleets were remarkably efficient, "Jutland" will show how slender was the amount of wireless information received from patrolling aircraft. On the other hand, intercommunication between ships reached a high standard.

Sir Louis Sterling

The directors of Electric and Musical Industries announce that they have with regret accepted Sir Louis Sterling's resignation from the position of Managing Director which he has held for the past seven and a half years. The Company was formed in 1931 to amalgamate the Gramophone Company (H.M.V.) and the Columbia Graphophone Company.

Interference-free Electrical Apparatus

BELLING AND LEE have been accepted by the British Standards Institution as an approved testing authority under the Radio Interference-Free marking scheme which was outlined in *The Wireless World* of April 13th.

Licences Fall

A DECREASE of 5,259 in the number of wireless licence holders during last month is indicated by the total number in force at the end of April which was approximately 8,962,850. This is believed to be the first case of a decrease in a month's figures since 1927. The past year's increase was 358,450.

"Camera caddies" at Golf Match

PLANS are nearing completion for the B.B.C. to televise a golf match from Combe Hill on June 1st. One mobile unit will be used, and the three cameras will be strategically placed to cover at least eight or nine holes. Between shots an army of "camera caddies" will heave the co-axial cable to different parts of the course. The Emitron cameras can now operate at distances up to a thousand feet from the scanning van.

Portable Transmitter

LISTENERS with a critical ear may be able to gauge the changes in signal strength as Henry Longhurst, broadcasting his description of the Amateur Golf Championship at Hoylake, Liverpool, on May 26th, traverses the greens and bunkers with the new B.B.C. knapsack transmitter.

News in Afrikaans

A TRANSLATION in Afrikaans of the weekly B.B.C. news for Empire listeners is now broadcast on Sundays in the short-wave programme at 7.30 p.m., B.S.T. The bulletin in English directed to South Africa is normally radiated at 7 p.m., B.S.T.

B.B.C. Audiometer Tests

THE B.B.C. is now using an audiometer in St. George's Hall to gauge the strength of applause for individual items. The first application of this almost infallible device is in connection with the "I Want to be an Actor" series. The audiometer is operated for fifteen seconds at the conclusion of each turn and the total volume of sound recorded affords a fair basis of comparison.

Italy After Montreux

THE E.I.A.R. seems quite satisfied with the Italian wavelengths allocated at Montreux. At present she operates in the medium band twenty-four stations on fourteen frequencies, four of which are exclusive. Next spring, when the plan becomes effective, she will be operating thirty-six stations on fifteen medium wavelengths, six being exclusive. The additional stations are all low-powered relay transmitters.

Touring Guide

A PROFUSELY illustrated 48-page touring guide is included free with each issue of the special touring number of our sister journal, *The Motor Cycle*, on sale to-day, May 18th. No fewer than thirty-three specially designed maps printed in two colours are contained in this guide, which has been specially prepared to introduce tourists to the most beautiful parts of Great Britain.

Learners

FOR those of our readers who are contemplating learning to drive a car we would recommend the third edition of "*The Autocar Guide for the 'L' Driver*," which explains in simple language what the beginner must be able to do in order to pass the driving test. The booklet is obtainable from booksellers price 1s., or from the publishers, Dorset House, Stamford Street, London, S.E.1, price 1s. 2d. post free.

Frequency Modulation in America

ANTI-NOISE BROADCASTING UNDER TEST

(Concluded from last week's issue)

THOUGH greatly decreased in size and number of adjustments, the set at present used for receiving frequency-modulated transmissions is fundamentally like its 16-foot ancestor. It remains a superheterodyne. A high-gain tuned radio-frequency stage is followed by the usual frequency-changer, an IF system of very high gain, a second detector and an audio system. However, one of the later IF stages is a "limiter" stage, prevented from responding beyond a certain amplitude, and the detector is preceded by a circuit designed to convert frequency swings into amplitude swings. In its simplest form the limiter IF stage is merely a pentode with reduced DC voltages, so chosen that its maximum performance is reached with 3 to 10 microvolts of carrier applied to the input circuit of the set. A signal increase of 10,000/1 then produces little increase of voltage at the succeeding valves, though there still remains the possibility of cross-modulating the incoming signal for extreme overload. The 3- to 4-stage IF systems thus made possible accounts for the ability of the receiver to utilise weak signals.

The detector is usually a balanced pair of diodes fed in such a way that the carrier affects them equally, but changes in frequency disturb the balance by an amount proportional to the extent of the frequency swing. In the original Armstrong receiver this was done by feeding each diode from a series-resonant tuned

IN last week's issue the results of receiving tests made on the experimental American frequency-modulated broadcast transmissions were described. This article deals with the special type of receiver necessary, and also discusses such matters as transmitter efficiency and details of modulation.

circuit in series with a resistor which preserved linearity. The two circuits were resonant on opposite sides of the carrier frequency and spaced widely enough to bracket the maximum swing. In the General Electric M-125 receiver there is used instead a circuit resembling the "discriminator" circuit used by the same firm in automatic frequency control systems. Here the two diodes are fed from the ends of the secondary of a 3-megacycle IF transformer, this secondary being coupled to its primary both magnetically (balanced) and by capacity (connected to the centre-tap of the secondary). At resonance the system is balanced and the two diodes receive the same voltage, though in opposite phase. Any departure from resonance produces phase shifts which upset the balance and feed unequal voltages to the diodes, whose rectified output feeds the audio system. The merit claimed for this system is greater sensitivity.

BY OUR NEW YORK
CORRESPONDENT

The audio system, loud speaker and cabinet demand the treatment normal to any true high-fidelity receiver. In the case of the Armstrong receiver there is used an audio system almost perfectly flat to 16,000 cycles. Degenerative feed-back and ballasting are used to remove various undesirable effects. The output tubes can deliver an undistorted output of 25 watts to a pair of speakers in a columnar baffle designed to load the "woofer" or low-pitch speaker. In the G.E. receiver audio degeneration (overall) is used with R. & C. ballasting at suitable points in the amplifier, which eventually feeds a maximum undistorted output of 15 watts to a 10-in. parabolic-diaphragm speaker with an exceptionally massive baffle-cabinet well braced and vented. The system is down only 5 db. at 15,000 cycles and has negligible harmonic distortion.

AVC and "Limitation"

Since the detector works at essentially constant level it cannot become a source of AVC voltage. A good limiter may compress amplitudes by as much as 100 db. Accordingly, AVC is derived from the limiter tube, but it is not certain that this feature will be retained.

According to the General Electric Company: "The cost of a frequency modulation receiver as compared to an amplitude receiver of equal quality is probably about

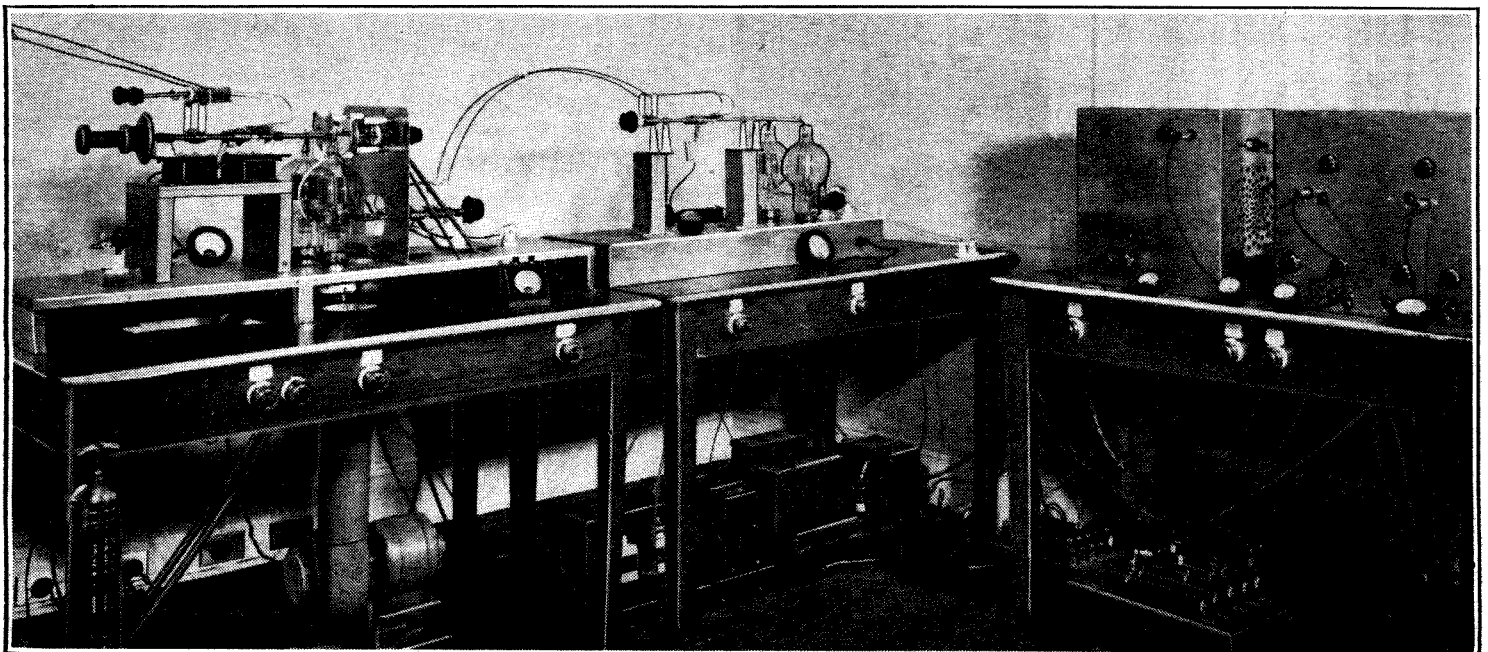

The power amplifying stages of the Yonkers station. On the right are the earlier amplifying stages, in the centre the push-pull driver and, on the extreme left, the push-pull output stage, which delivers 600 watts at 110Mc/s. The output valves are air-cooled by a blower under the bench.

Frequency Modulation in America—

the same. In general, however, the cost of the frequency-modulation receiver will be higher since the fidelity will ordinarily greatly exceed that of the amplitude-modulation receiver, requiring additional expense in the audio and reproducing system."

For equal power and frequency the cost of the frequency-modulated transmitter may not differ greatly from that of an amplitude-modulated transmitter. The ability to operate at steady load effects savings sufficient to pay for the added low-power stages.

It has already been stated that the valves operate more efficiently for the same frequency. Thus the W2XMN transmitter, still working on 7 metres, might be modified, as in the following table, using the same final valves as at present.

Modulation method	Valve capacity	40-Mc/s carrier output	Carrier possible at low frequency
Low level freq. mod.	(kW.) 2 × 50	(kW.) 40	(kW.) 100
Low level amp. mod. and Class B final ...	2 × 50	10	25
High level amp. mod.	2 × 50 plus 2 × 50 for modulators.	40	100

Note.—This theoretical tabulation is not altogether fair to the Armstrong system in practice. Whereas W2XMN has met with no service failures during 5-hour runs at an output of 40 kilowatts, other transmitters using output valves of the same type have encountered difficulty in maintaining very much smaller carrier powers at about the same frequency with amplitude modulation.

Both the second and third systems are less efficient in the use of power, and produce unsteady loads on the power line. The second system produces less output. The third system requires more large valves.

Simply as a matter of review, the Armstrong method of frequency modulation is that of splitting a low-frequency carrier (say 200 kc/s) into two streams so that one may continue as an unmodified carrier while the other stream is passed through a balanced modulator and inductive amplifier before the two channels are recombined in a resistive load. The balanced modulator as usual delivers only side-frequencies, having balanced out the original carrier. The inductive amplifier produces phase shifts in the side-frequencies, proportional to the amplitude of modulation, and these phase shifts are subsequently much increased by passing the modulated carrier through many frequency multiplications. Various devices for preserving linearity need not here be mentioned. Some intentional nonlinearity is allowed to remain for the purpose of securing exaggerated high-pitch modulation and thereby better over-riding of residual noise. This is compensated at the receiver.

Maximum Permissible Swings

Over-modulation does not have as definite a meaning as in amplitude modulation, but for optimum performance the deviation or swing used should be that for which both sender and receiver were designed. In any case, the swing should

be materially wider than the audio channel, i.e., a 15,000-cycle audio channel requires a swing of 4 to 10 times 15,000 cycles on either side of the carrier frequency.

Various investigators agree that for fluctuation or "ground" noise the improvement in signal-noise ratio is

$$1.7 \frac{\text{frequency deviation}}{\text{audio band width}}$$

and also that for "impulse" noises, such as ignition, most static and many power-line noises, the improvement is

$$2 \frac{\text{frequency deviation}}{\text{audio band width}}$$

However, there is less perfect agreement as to the range in which these effects take place, that is, the ratio of carrier-to-noise required before the action begins. From what has previously been said it is apparent that the threshold, if any, is low. There is at least agreement that noise reduction has definitely set in when the limiter valve has "taken hold," and this takes place in various of the present receivers with carrier input (to the receiver) of from 2 to 10 microvolts. Any given value of field strength is more easily attained with frequency modulation, since peak power is used constantly.

The Armstrong receiver derives an advantage from another effect. The accompanying oscillogram (a) is that of an atmospheric crash in the form it had assumed upon reaching the loud speaker or output transformer of a conventional General Electric K-80 receiver. The oscillogram (b) is produced in the same receiver by discharging a condenser into one of the tuned circuits.

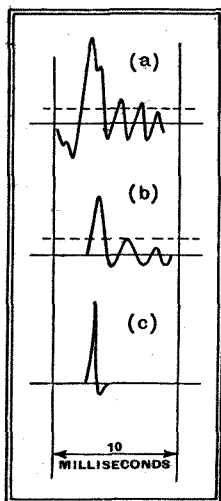

The resemblance clearly shows that in both cases the original disturbance shocked the receiver-tuned circuits into oscillation. Oscillogram (c) shows the waveform of an atmo-

Oscillograms of impulse interference: (a) and (b) are to the same scale.

spheric crash about two minutes later with the oscilloscope connected across an approximately critical series resistor in the aerial, the receiver being removed. All three oscillograms are typical for this particular thunderstorm.

The dotted lines represent the approximate level of the amplitude-modulation peaks due to voice modulation on a carrier which, prior to modulation, delivered about 1,600 microvolts to the receiver input. The waveform (c) can be eliminated more completely if attacked by an amplitude limiter before its form factor becomes altered by conversion into an oscillation such as (b) or (a). In the normal amplitude-modulation receiver this is a difficult condition because of the "fly-

wheel" effect of the high-Q circuits essential to normal selectivity with good gain. In a broad-band system this difficulty is materially lessened and (for any sort of modulation) the limiter becomes more effective. However, it is especially so for amplitude modulation, since there is no possibility of peak-cutting distortion, and therefore the gain ahead of the limiter is normally kept high enough to ensure limiter action.

If station W2XMN is taken as typical, the off-hand impression is that the channel width required for Armstrong modulation is some 20 times that occupied by an amplitude-modulated station.

Possibilities of Sharing Channels

This is a great mistake. It is to be remembered that W2XMN and W2XCR both transmit high-fidelity signals. The comparable amplitude-modulated transmitter would require a channel 40 kilocycles wide, in which it would place two side-bands about 16 kc/s wide, leaving a 4-kc/s guard-band at either edge. Thus for the same fidelity (noise not considered) the amplitude-modulated station requires 1/5th the band width, not 1/20th. Nor could amplitude-modulated stations be spaced more closely without sacrifice of fidelity—one need only listen to the nearest good receiver to discover that. On the other hand, for frequency modulation not only is closer spacing permissible, but two stations can operate on the same frequency with *much less* "hash area" than is found for amplitude modulation.

These somewhat surprising statements have both theoretical and experimental proof. First as to the requisite spacing of two FM stations *not* working on the same frequency. Referring back to the early public discussions by Major Armstrong, it will be recalled that he pointed out an advantage of wide-band or large-deviation frequency-modulation due to the fact that the beat-frequencies generated in conjunction with noise-frequencies remote from the carrier position were either self-cancelling in the detector or inherently inaudible, hence that a wide swing permitted most of the operation to take place in regions incapable of contributing noise (other than high level impulses which can still contribute to some extent by cross-modulation), thus doubling the band width quadruples signal-over-noise in terms of power. Now if two FM stations delivering comparable signal strength are centred with a supersonic separation between their carrier positions, many of the resultant beat-frequencies are eliminated by approximately the process above referred to, while others are eliminated by the effect mentioned in the next paragraph.

Where two FM stations are operated on the same channel there ensues an effect which comes as a pleasant surprise. It is this: if one signal is of more than double the field strength of the other—that is, 6 db. superior to it—that signal takes possession and the other disappears. Messrs. W. E. Fyler and J. A. Worcester reported an experiment done with a 50-watt trans-

Frequency Modulation in America—mitter at the General Electric plant in Schenectady, New York, and a 150-watt transmitter at Albany, 15 miles away over

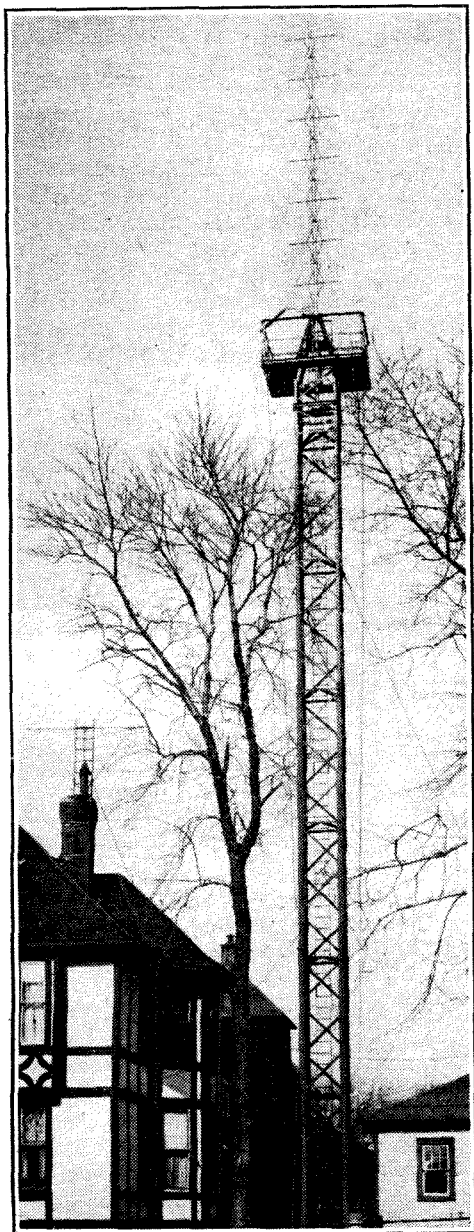

The "turnstile" aerial at W2XCR, formerly W2AG, at Yonkers, N.Y. It comprises 14 sections and is supported by a roof-tower.

open country. Both transmitters operated on 41-Mc/s and could be modulated by either method.

Tests were then made with a portable receiver at various points along the road between the two stations. With amplitude modulation there appeared the familiar effect that the station spoils far more territory than it uses. Of the 15 miles of road 13 were occupied by a dismal garble. With Armstrong modulation the effect was altogether different; for nearly 13 of the 15 miles there was no interference at all. The remaining 2 miles showed a mixture of the two stations, but not in the usual way. As the receiving car proceeded the stations popped in by turns as one or other attained the requisite 6 db. superiority due to the standing wave pattern inevitable at 40 Mc/s. By stopping the car it was possible to find a cross-over point so

sharp that one station or the other could be selected by pushing the aerial over an inch.

The difference lies in the fact that for conventional amplitude modulation one station must attain a superiority of 30 to 40 db. (say 250 times) before it can swamp the other. In the large area where garbling exists it is difficult for a listener to escape the effect, since an aerial capable of providing so large a directional discrimination is too complex for household use—and at wavelengths of more than 10 metres becomes very costly. On the other hand, the smaller area of interference of the FM system is due to level differences easily counteracted by an aerial with one director or reflector. If one were content simply to listen to one of the two stations no directionality at all would be needed even in this area except for the fact that the standing-wave pattern moved from time to time, giving an effect like that of the aerial movement above described. For a considerable distance on either side of this area the dipole plus director or reflector (or at the most both) suffices to select either station at will. At points nearer to one station or the other one is merely in the normal state of the present-

day listener, but with fading reduced in an exceptionally good degree.

At the April 10th meeting of the Washington Section of the Institute of Radio Engineers, Mr. I. R. Weir, of the General Electric Company, reported on a further test of the same kind, made by observers in two cars driving from an experimental 200-watt Armstrong transmitter at Albany, N.Y., towards the 40-kilowatt W2XMN transmitter 120 miles away. The transmitters were on the same frequency. From Albany to Hudson, N.Y. (30 miles), the Albany 200-watt sender blocked off W2XMN, which remained unheard up to that point. At Hudson, which is well into the hills, W2XMN began to break through, being heard on the south side of each hill, while the north side still produced the G.E. 200-watt transmitter. The effect was similar to that in the Schenectady-Albany test previously cited, that is, the stations alternately took possession of the receiver. A few miles farther south W2XMN "took over" permanently and Albany's signal was heard no more. It is to be noticed that the cross-over region seems to be too close to W2XMN, but this is accounted for by massive highlands to the south towards W2XMN.

Test Report

INVICTA NEW JUNIOR PORTABLE

Four-valve Superheterodyne Battery Receiver

Price £7 15s. (including batteries)

ALTHOUGH taking up no more space than the early type of battery portable with a straight circuit, this receiver has a full superheterodyne circuit which gives considerably greater range and selectivity for an expenditure of only a few more milliamps of HT current.

The provision of a superheterodyne circuit carries with it the advantage of being able to employ automatic volume control, which is of great value in a portable where the directional properties of the frame aerials may produce considerable variations of the input voltage. With

automatic volume control one need not be so careful over the placing of the set, but at the same time the advantages of a frame aerial from the point of view of cutting out interference are not lost. If anything, the "minimum" is sharpened by the action of AVC.

Circuit.—The input, from the frame aerials is taken to the grid of an octode frequency changer. The next stage is a variable mu pentode operating at 465 kc/s. The coupling transformers have silvered mica fixed condensers and are adjusted at the works by moving the position of the iron dust core. The double-

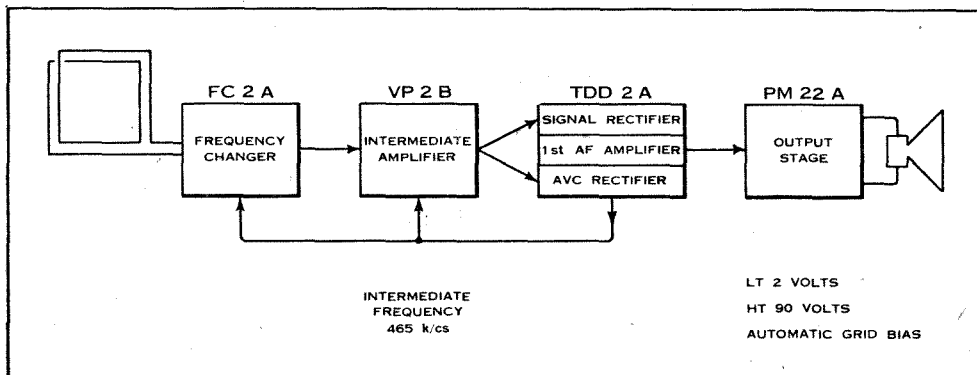

Schematic circuit diagram of the Invicta New Junior portable.

Invicta New Junior Portable—

diode-triode valve which follows is connected in the usual way with one diode for signal rectification and the other for AVC. The bias derived from the latter diode is applied to both the IF and frequency-changer valves. The volume control takes the form of a potentiometer input to the triode amplifying portion of the second-detector stage, which is transformer coupled to the pentode output valve. A resistance in the negative HT lead provides bias for the output stage, and the delay voltage for AVC.

Performance.—The measured LT current was 0.5 amp., and the total HT current 14 mA from the 90-volt battery.

use of the directional properties of the frame.

The most notable feature is the ease with which these results are obtained. Whereas with a straight receiver a very good performance can be obtained by skilful use of the reaction control, in this set the work is all done by the circuit, and the volume control is the tap which turns on the finished results.

The Celestion loud speaker, which, incidentally, has a really sensible output transformer as far as size is concerned, gives efficient conversion of the output available from the last valve. Provided the volume control is not turned up too far on the local station, the quality is per-

WAVERANGES	
Medium	- - 200—550 metres
Long	- - 800—2,000 metres

ected being one of the reasons for the compactness of the chassis. As a result there is ample space for batteries, and the LT battery is of 18 ampere hours capacity. This is of the unspillable type, but it should be examined after coming back from charging to see that there is no acid on the outside, as it is rather near to the tuning condenser vanes and the oscillator coil can.

The collapsible carrying handle is well placed from the point of view of balance of weight, and the cabinet is fitted with a turntable. The total weight is 21¼ lbs.

Summary.—The makers have achieved a very efficient performance with simplicity, and hence potential reliability in the design and layout of the chassis. In conclusion, we would commend the circuit diagram and list of component values which are pasted on the inside of the back panel of the set for the use of servicemen.

HENRY FARRAD'S SOLUTION

(See page 462)

TONY has overlooked the fact that a lamp run on a 50 c/s supply flickers every half-cycle, that is to say, 100 times per second. Therefore, he should have put on 77 stripes. The time taken by the turntable to rotate through a distance equal to that from one stripe to the next would then be a hundredth of a second when running at the correct speed, and the stripes would all have shifted exactly one place round when next most brightly illuminated and hence would apparently stand still, according to the principle of stroboscope action.

The Wireless Industry

SOLUTIONS for silvering mica and ceramic dielectrics are the subject of a booklet entitled "Liquid Silver" issued by Melton Metallurgical Laboratories, Seymour Road, Slough, Bucks.

A new edition of the leaflet dealing with rotary converters for radio, television and PA equipment has been issued by the Electro Dynamic Construction Co., Ltd., St. Mary Cray, Kent. It includes a three-page list of prices of complete power supply units for all the leading makes of receivers.

Mack Radio Stores, Elphinstone Street, Camp, Karachi, India, would like to receive catalogues and price lists from manufacturers of wireless components.

The suppression of interference from DC and other commutating machines at the source is dealt with in Rado Interference Bulletin No. 60 issued by Belling and Lee, Ltd., Cambridge Arterial Road, Enfield, Middlesex.

Mr. W. E. Wilkins, B.Sc., A.M.I.E.E., the Northern representative for Westinghouse metal rectifiers, has changed his address to Agden Lane Farm, Agden, Lymm, Warrington.

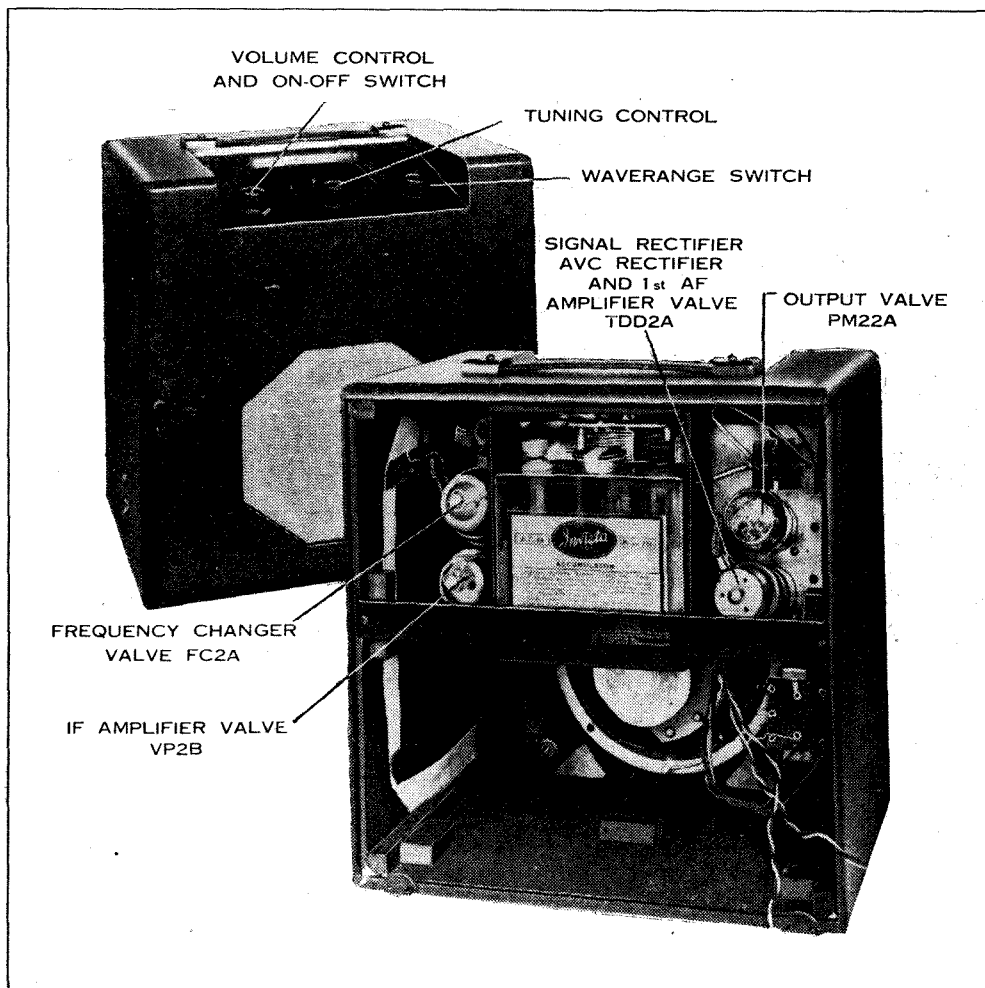

Although the chassis houses a superheterodyne circuit, it is remarkably compact and leaves plenty of room for batteries.

Although this is appreciably greater than the average HT consumption for a simple straight set, there can be no doubt as to the additional return in the matter of performance.

The number of stations received on both the medium- and long-wave bands is comparable with that to which most people are accustomed with their four-valve superheterodyne table models, and the selectivity is also practically the same. In other words, the London Regional transmitter at a distance of fifteen miles does not spread more than 1½ channels on either side of its normal setting, and the Deutschlandsender could, under favourable conditions, be received clear of Droitwich and Radio-Paris by making

fectly clear and is not marred by any attempt to produce an artificial bass resonance. On all stations other than the local the volume control may be disregarded, as the range of AVC is sufficient to prevent overloading.

Constructional Features.—Separate frame aerials are mounted on opposite sides of the cabinet. They are of interesting design, and the turns are self-supporting. It would appear that the coils are first of all wound as a short cylindrical single layer, and then folded over at the corners to produce a flat edgewise coil.

By careful disposition of the components it has been found possible to dispense with screening for the IF transformers, the economy in space thus

Television Topics

SAW-TOOTH CURRENT WAVES

MAGNETIC deflection of the electron beam necessitates a saw-tooth current through the deflecting coil. Such current may be generated by connecting the coil to a source of constant potential. The resulting current rises slowly for the scanning stroke. If the potential supply is disconnected so that the current may cease for the flyback, the coil begins to oscillate freely (with the circuit capacity or the self-capacity of the coil). If this operation is interrupted after the completion of one half-oscillation and the coil is

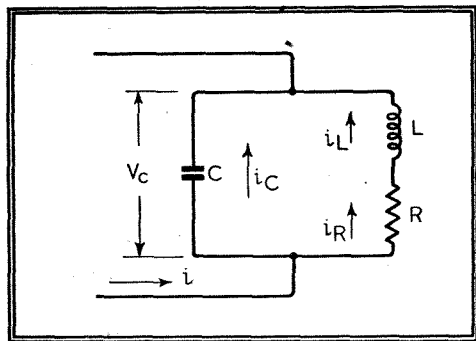

Fig. 1.—This diagram shows the basic circuit of the deflecting coil; R represents the coil resistance and C the circuit capacity.

connected again to the potential supply, the current rises again in a linear way. The free half-oscillation, therefore, represents the short saw-tooth stroke.

With such a generator of saw-tooth currents it is important that at the moment when the half-oscillation is released by the linear rise, the exact conditions of connection are present (equal absolute value of the current and equal first-time differential quotient). If this is not the case, balancing oscillations occur. These must be avoided because they cause interference on the picture.

In deflection circuits for television purposes the winding capacity of the coils is so small that for the frequencies in question the damping given by the ratio L/C of the coil practically suppresses the balancing operations. If a coil of this kind has to be fed through a cable with the saw-tooth current, it is possible that the additional output capacity of the cable may alter the ratio L/C in such a way that the coil is only damped comparatively slightly and that the desired current curve is falsified by balancing operations. Additional damping of the coil is not always possible in view of the current stroke to be applied, and, on the other hand, an extension of the short backward oscillations is also rarely permissible.

In Fig. 1 is shown the coil L in series

with its ohmic resistance R, and parallel to both is the distributed winding and lead capacity C. Through the coil L a saw-tooth-shaped current (i_L) has to flow, and the question is what current i has to be supplied to the arrangement so that no balancing oscillations are possible.

Fig. 2(a) shows the curve of the required coil current. The linear current rise passes the value zero at the moment of time t_0 . At the moment of time t_1 the linear curve is released by the sine half-oscillation. (Both operations follow each other with equal di/dt .) The maximum value is not reached at t_1 , but a little later at t_2 . In accordance with the fact that the coil oscillations are damped, the negative maximum amplitude is drawn smaller than the positive amplitude. The negative maximum value is reached at t_4 , and at t_5 the linear rise starts again, which passes again the zero axis at t_6 .

The potential existing at the coil L may be easily constructed from this current curve; it is the differentiated curve (Fig. 2(b)). The potential V_c of the condenser C is the sum of the potentials at the coil L and at the resistance R. The latter is proportional to the curve (a), and for the sum of the coil potential and resistance potential shown in Fig. 2(c) the proportionality factor R is taken as 1. From the curve of the potential present at the condenser the current causing this poten-

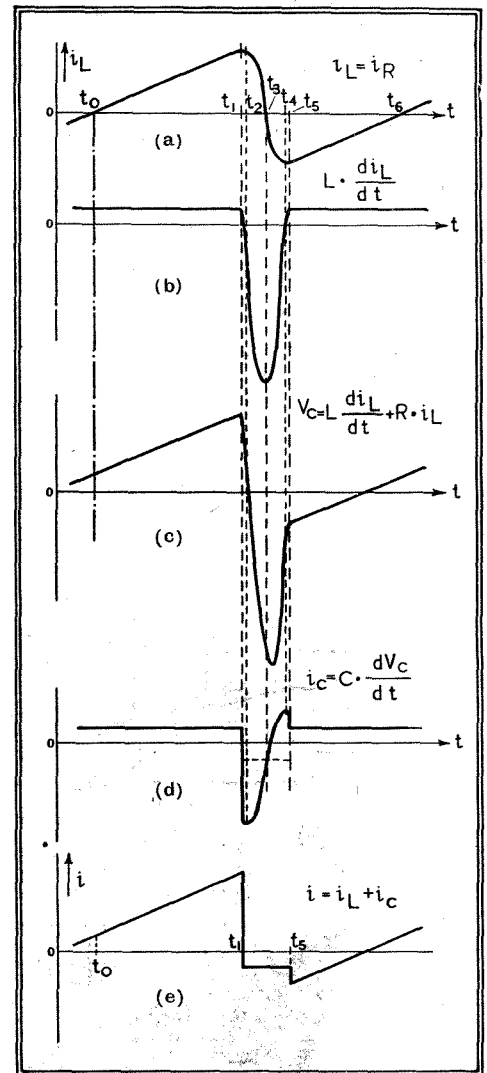
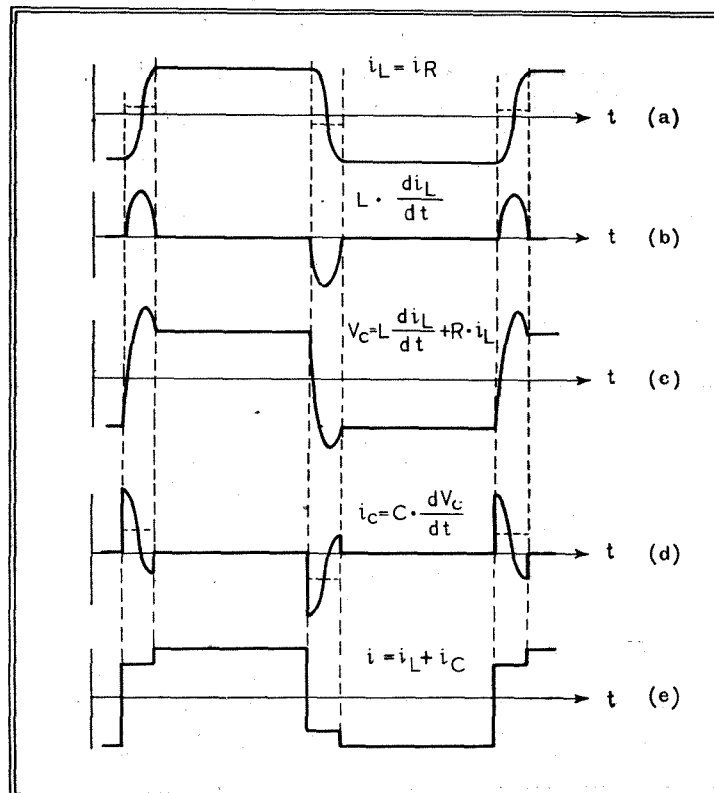

Fig. 2.—The method of determining the relation between the coil and input currents is shown here. (a) represents the desired coil current, (b) the voltage across the coil, and (c) the voltage across the condenser; (d) shows the condenser current and (e) the line current.



tial curve can be obtained by another differentiation (Fig. 2(d)). It is to be observed that in (c) the negative maximum value of the condenser potential is not reached at t_3 , but only a little later. Accordingly, in (d) the current value zero is passed after t_3 . The curve of the condenser current i_c is exactly equal, but in a reflected sense, to the first postulated coil current, which is

Fig. 3.—These diagrams are similar to those of Fig. 2, but for the case where a rectangular coil current is desired.

Television Topics—

obvious because the current always swings backwards and forwards between L and C. This equality does not, however, hold

is not limited to saw-tooth currents. As a further example may be considered the case where a rectangular current has to flow through the coil L as in Fig. 3(a).

This leads in a similar way to the curves of Fig. 3(a-e). Here, again, a step-shaped current i is produced which causes the coil to oscillate in the desired way without balancing operations. As the coil oscillations are damped they take place in Fig. 3(a), not around the zero axis of the current, but around the parts of the axis which are shown in dashed

Fig. 4.—These diagrams illustrate the steps in obtaining a circuit to give a voltage waveform which is the same as the current wave of Fig. 2 (e).

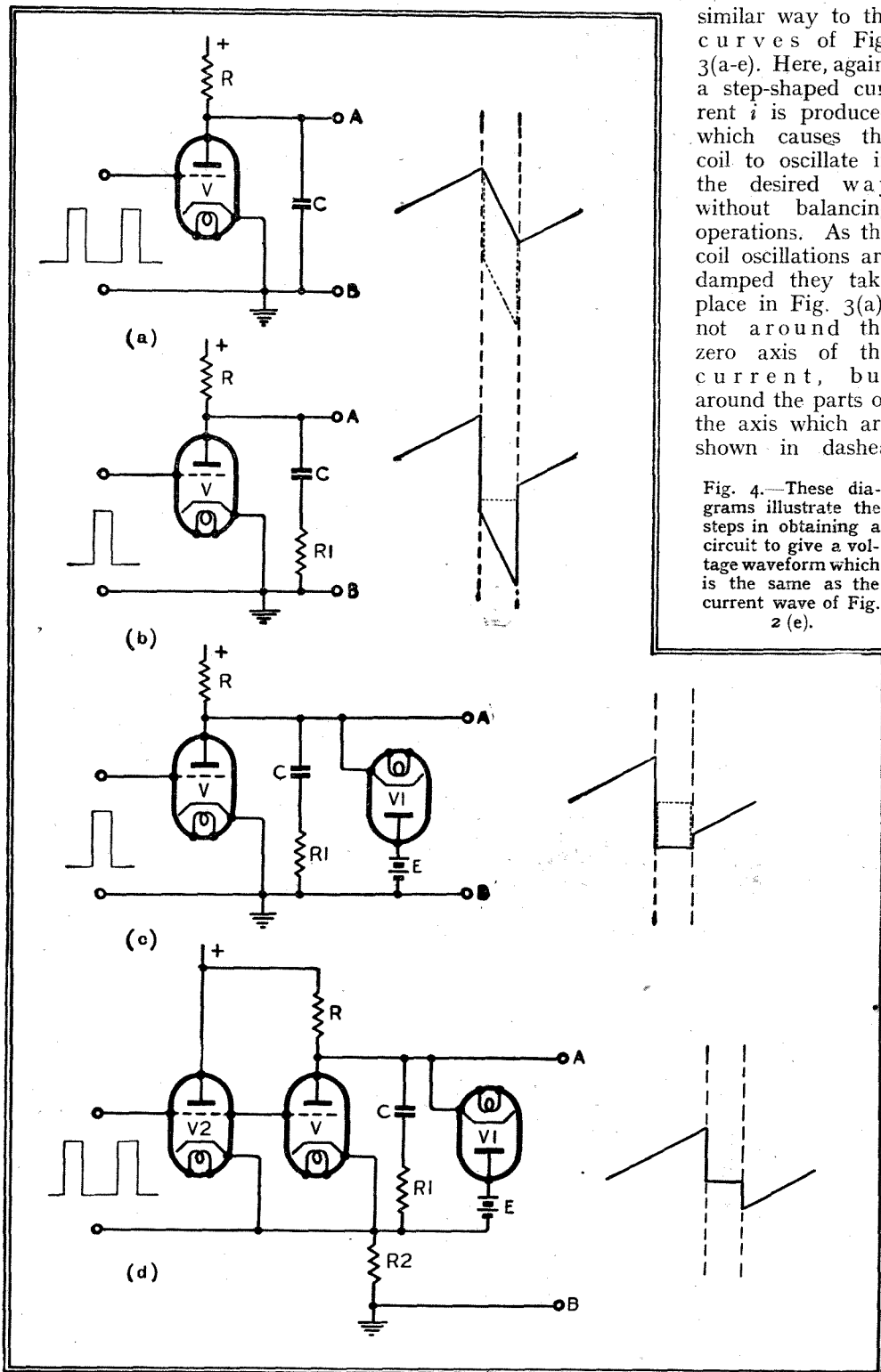

In Next Week's Issue

CATHODE - RAY OSCILLOSCOPE.
How to make a simple general-purpose oscilloscope for operation with a 2½-in. tube.

AERIAL MASTS. Problems of mechanical design; choice of types; strength and other properties of materials.

DC MAINS SUPER. Constructional details.

the valve V, which is controlled by positive impulses on the grid. A saw-tooth potential is developed across C.

If a resistance R_1 (b) is connected in series with the condenser a potential is present at the terminals A and B, which consists of a saw-tooth and a superimposed impulse as shown on the right. If a rectifier V_1 with a potential supply E is connected in parallel with the condenser C and the resistance R_1 (c), the result is that the impulse is cut off horizontally parallel to the t axis. If, during the impulse, a positive impulse is added to the existing impulse we obtain the required step-shaped potential curve which, if used as a control potential for a pentode, produces the desired step-shaped current curve. In Fig. 4(d) the circuit of Fig. 4(c) is raised by the potential drop across a resistance R_2 connected in the cathode lead of a discharge valve V_2 , which is controlled by positive impulses in a similar way to the valve V. In Fig. 4(a-d) (right-hand side) the potential curve existing between the terminals A and B is shown, and the potential which is obtained at the next stage is indicated by dotted lines. This method of determining the circuit characteristics necessary has been developed by the Telefunken Co.

New Apparatus

"OMCO" DUMMY ANTENNA

THE adjustment of amateur transmitters is generally carried out on an artificial load resistance consisting of a standard

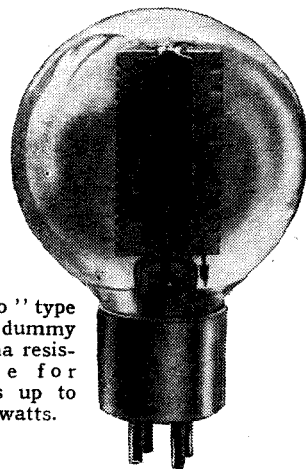

"Omco" type D.100 dummy antenna resistance for powers up to 100 watts.

tungsten- or carbon-filament lamp. The resistance is usually doubtful and the impedance at RF unknown. Such a simple device is therefore unsuitable where measure-

good for the zero axis shown in Fig. 2(d), but for the dash-dot axis for which the current value zero is passed at t_3 . The dash-dot axis follows from the necessity for the areas enclosed by the current curve to have the same proportions, determined by the damping, as in the curve of Fig. 2(a). If the currents of Figs. 2(a) and (d) are added together, we get the current i which is required by the whole arrangement. This current is shown in Fig. 2(e) and is of step shape.

This method of determining the current

lines. In accordance with the damping, the curve in Fig. 3(b) is somewhat asymmetrical. In spite of this, the condenser current (Fig. 3(d)) has a half-oscillation which is the same but in a reflected sense as the coil current.

The generation of the necessary current curves may readily be carried out, and the necessary steps are shown in Fig. 4 for the case of a saw-tooth coil current. At (a) a condenser C is charged from the HT supply of the discharge valve V through a resistance R, and is discharged through

ments of output power and efficiency are required.

To meet this difficulty the "Omco" dummy antenna has been developed. The resistance element is an opposed two-layer coil of fine wire widely spaced on a mica former and enclosed in a gas-filled bulb mounted on a 4-prong base which fits the standard American-type valve holder.

By a careful choice of material for the wire and adjustment of the residual inductance in relation to the distributed capacity it has been found possible to render the resistance independent of both frequency and load up to 15 Mc/s and 100 watts. In practice it may be used without appreciable error up to at least 22 Mc/s. Two types are available, with resistances of 73 and 600 ohms. The former has an inductance of 0.33 μ H and the latter of 1.1 μ H. The distributed capacity is the same in both types, namely, 5 micro-mfd.

The price is £1 and retail supplies are obtainable from Webb's Radio and G5NI (Birmingham), Ltd. Trade enquiries should go to Electronic Engineering Services, Ltd., Swakeleys Road, Uxbridge, Middx.

(December 22nd and 29th, 1938). The mains transformer (EP45), which is in

The new Varley beat-frequency oscillator coil is fitted with a fine adjustment which is adaptable for front-panel control.

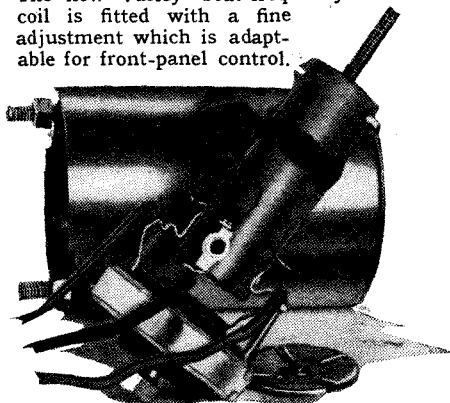

skeleton form with leads for direct connection in the circuit, has an electrostatic

shield between primary and secondary and gives 90 mA at 300-0-300 volts, 2 amps. at 4 volts, and 3 amps. at 6.3 volts. The primary is tapped 200, 220, and 240+10 volts.

The smoothing choke (DP56) is also fitted with loose connecting leads, and gives an inductance of 30 henrys at 90 mA with a DC resistance of 800 ohms. The price of the choke is 12s., and of the mains transformer 22s. 6d.

Marconi and Osram KT44

A NEW valve intended primarily for use in magnetic time-base circuits has been released. It is the Marconi and Osram KT44, and has characteristics similar to the well-known KT66. Its heater rating, however, is 4 volts 2 amperes, and it has a 7-pin base with a top-anode connection. It is priced at 15s.

Film Industries 6/15/PP Amplifier

THIS compact and low-priced 15-watt amplifier is supplied in kit form with blue prints and full instructions for wiring. The chassis is of channel section, and is constructed of 16 SWG steel with all holes drilled ready for assembling the components.

There are two input circuits with a centre-tapped fader, and the output transformer has tapings giving output impedances of 4, 8 and 16 ohms. The first stage is a resistance-capacity coupled triode with a shunt resistance-capacity tone control across

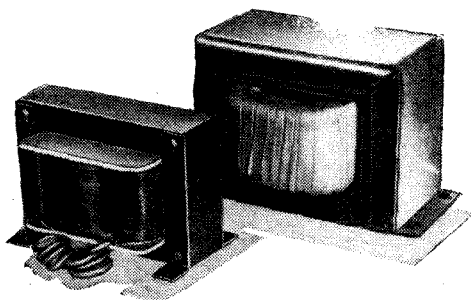

Varley mains transformer and choke for the Three Band AC Super.

RECENT VARLEY PRODUCTS

THREE components of interest to readers of this journal have recently been submitted by Varley. The first is a new beat-frequency coil assembly designed for receivers of the communication type. It is made in two values to beat with IF stages working at 465 kc/s or 1,600 kc/s, and is intended for use in an electron-coupled oscillator with a screen-grid or RF pentode valve.

Coarse adjustment of frequency is effected by a bottom-capacity trimmer screw, and fine adjustment by an inductance trimmer passing through the top of the can. A range of 10 kc/s is given for 180-degree rotation of the latter control, and a shaft adaptor and mounting bracket for front of panel control is available, price 6d. The 465 kc/s coil costs 6s. 6d., and the 1,600 kc/s coil 5s. 6d.

The other two components have been produced for the power supply circuit of *The Wireless World* Three Band AC Super

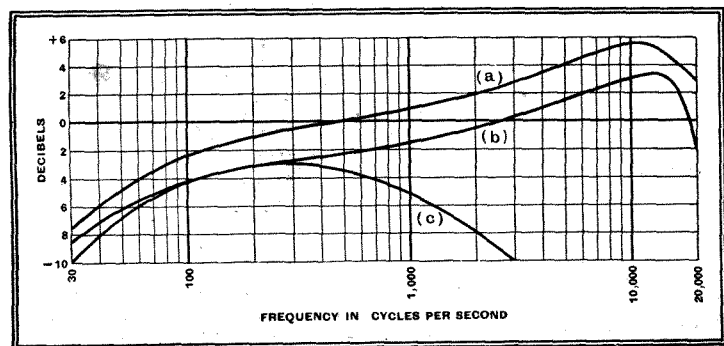

Frequency response of the Film Industries 6/15/PP amplifier with the tone control (a) in the maximum, (b) midway and (c) minimum high-note positions.

its anode circuit. The second stage, also a triode, is transformer-coupled to two 6N6G double-triode output valves operated in Class B push-pull. High-tension current is derived from an MU14 rectifier with one stage of smoothing. A fuse

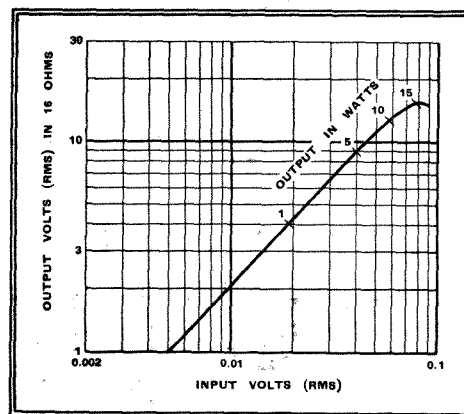

Input-output curve of the Film Industries amplifier at 400 c/s. Output resistance 16 ohms.

is included in the HT circuit as well as in the mains leads. The mains transformer is adjustable for AC mains between 200 and 250 volts.

The group of three frequency characteristics taken with the tone control in the minimum, maximum and midway positions indicate that the flattest response will be found somewhere in the first half of the range of tone control. The rising character-

istic at maximum high-note response is useful, and will no doubt be appreciated for PA work where clarity of diction is important.

An output of 15 watts is reached with some overloading apparent on the cathode-ray tube. Departure from pure sine wave is discernible when the level passes 5 watts. Full output was reached for an input of 0.08 volt.

The amplifier should prove useful, among other things, for modulating amateur telephone transmitters, and has, in fact, already demonstrated the good quality of reproduction it is capable of giving under these conditions.

The makers are Film Industries, Ltd., 60, Paddington Street, London, W.1, and the price is £9 9s.

15-watt amplifier built from a kit of parts.

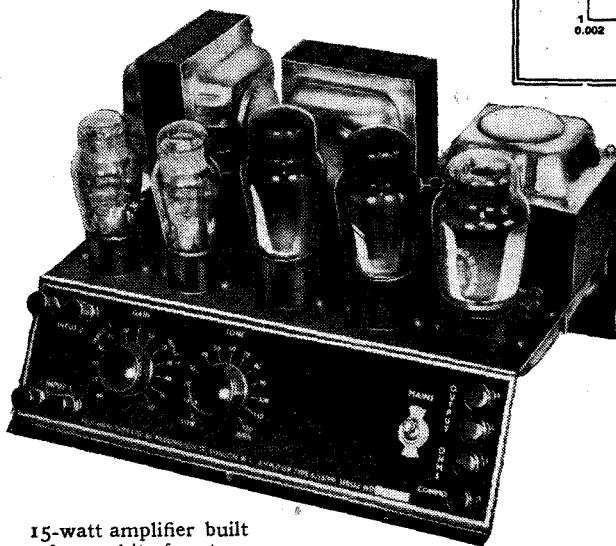

Random Radiations

Not So Easy

AT a friend's house the other evening my eye was caught by a new "all-wave" receiver standing in the place previously occupied by something that, to say the least of it, wasn't exactly up to date. "Hullo," I said, "you've gone in for a new set, I see." He told me that he'd had to, as the reproduction of the old one had become so awful that he couldn't stand it any longer. I had been wondering for many months how he could stand it at all! "Do you make much use of the short-wave range?" I asked. His reply was that he'd tried it once or twice, but hadn't found much except for the Empire transmissions and one or two Europeans, and had decided that the tuning was a bit too difficult for him. He thought that the set must be capable of bringing in short-wave stations in countries farther away, he'd like to be able to bring some of them in at times; but he didn't feel up to doing the niggling and fiddling with the tuning knob that appeared to be called for.

Worth Thinking Over

At his suggestion I tried the receiver. It wasn't one of the small, cheap "all-wave" sets. By to-day's standards the price paid for it wasn't a low one, and it was obviously good value for money. On the medium and the long waves it was a distinctly good performer and quite easy to handle. But when I turned to the short-wave range I found myself in deep waters. To a sketchily calibrated scale, some six inches in length and covering about 12.5 megacycles, add a thick pointer and a not-so-slow-motion drive not entirely free from backlash, and the process of tuning in a distant station becomes almost as exasperating as doing one of those horrible puzzles which call on you to separate inseparable keys or to shake steel balls into inadequate holes. I did manage to get hold of a number of distant stations, but it wasn't easy. I asked my friend if he wouldn't gladly have paid an extra pound for simpler tuning arrangements on the short waves. He most certainly would, and as there must be many like him, I pass on the hint to set manufacturers.

The Rustlers

ARE you annoyed by the paper rustling in which some announcers and some speakers indulge when they are before the microphone? I must say that I am. Lately we seem to have had a good deal more of it than for some time past. Possibly announcers have been agitated by seeing larger crops of fearsome foreign names than usual on the typewritten sheets before them. Possibly we have had more than the normal quota of speakers new to the microphone and suffering from fright thereof. I don't know; but I'm sure that paper rustling has increased for some reason or other. Years ago I made the suggestion that the news bulletins, at any rate, should be typed on some fine washable fabric such as cotton or linen instead of paper. I still think it would be a good idea; but if it's not practicable, the paper manufacturers, if asked, would doubtless put their heads together to produce a rustle-pooof paper intended specially for broadcasting purposes. With

By "DIALLIST"

so many stations in the world to-day, all giving such quantities of news items and talks, the demand should be considerable.

The Real Enemy

I'VE always believed firmly that television's greatest enemy in the London area is not the cost of the apparatus necessary for receiving it, or the shortness of the programme hours, or the comparative smallness of the domestic screen. The real foe is interference, particularly that produced by car ignition systems. Go into the average dealer's shop and witness a demonstration of television. At intervals, depending on the density of the traffic stream in the neighbourhood, the images on the screen are all but blotted out by a snowstorm, whilst noises that are anything but pleasant are torn from the loud speaker. The demonstrator explains that that's merely a passing car, which he can't help; the would-be purchaser reflects that motor cars are not unknown in the neighbourhood of his house. He is told, possibly, that it will be "quite easy" to get rid of the interference at his home. If it's so easy, he cannot help wondering why the dealer hasn't rendered his demonstration room immune!

A Big Problem

From articles and letters that have appeared from time to time in *The Wireless World*, one surmises that, though some cars may not have their performance seriously affected by some interference-suppression systems, there is as yet no system that will adequately (and satisfactorily) cope with all cars. It's a very unsatisfactory position, and it's high time that the car manufacturers and the radio industry went into a huddle to tackle this serious problem by co-operative effort. Here we are, on the one hand, spending immense sums to develop the broadcasting of entertainment on the ultra-short waves, and, on the other hand, producing vast quantities of motor-driven vehicles so designed that each one that takes the road is doing its bit towards making the use of these waves more difficult. Given a fair chance, the ultra-short waves might play an even more important part in human affairs than the medium and long. But if they're not given that chance they may become in time all but useless.

Creeping

PERHAPS I'm wrong, but I don't notice much improvement in the matter of oscillator creeping in the moderately priced class of receiver. I was using one recently which wouldn't hold even the local stations! If, for example, I adjusted it carefully to resonance with the London National at the beginning of the nine o'clock news bulletin, the announcer's S's sounded like the release of soda-water from a syphon before he was half-way through his reading. This wasn't a press-button set, though I'd had sets of that kind that were almost as bad. Another set would creep from one station to another on the short waves, if left to itself; in fact,

to hold a transmission you had to be constantly juggling with the tuning knob. One would have thought in these days of button-tuning the problem of oscillator creep would be receiving plenty of attention. Creep is preventable, of course; but to do so puts up costs, and that, I suppose, is the reason why it is found in so many of to-day's sets.

W6XBE in S.A.

FROM Johannesburg comes a letter telling me of R8 reception of W6XBE, the new General Electric short-wave station. Its writer is surprised at his success. As the station's beam for the transmission that he heard was directed on Asia, he suggests that some lateral refraction must have been taking place for it to be heard so strongly in South Africa. I don't think so. W6XBE is on Treasure Island, San Francisco. I haven't had time to work out the Great Circle course, but, so far as I can see by looking at a terrestrial globe, a continuation of the path between San Francisco and Southern Asia would pass not a long way from Johannesburg. In the ordinary way, I learn, American broadcasting stations on the short waves are not well received in that city. I predict, though, that my correspondent will be able to receive this beamed transmission from W6XBE on most days when conditions are not unfavourable. By the way, the time at which he heard the broadcast that he reports was a little before 15.00 GMT. The frequency was 9.53 Mc/s.

Water Wears Away a Stone

YOU can't help feeling sorry for the fellows who come round trying to sell vacuum cleaners; theirs is a hard job, and I'm afraid that one is apt to be a bit short with them. I always try to be as gentle with them as I can when they manage somehow or other to penetrate the outer defences to my den. The other day, though, I couldn't help asking one of them whether the one that he was demonstrating was guaranteed not to interfere with wireless. He professed to think that it was innocuous, so I got him to turn it on and then switched on the set, with the usual results. "My wife does want a new one," I said, "but I've sworn an oath not to buy anything that causes interference. Tell your people that you've lost a possible sale because yours does." If readers would take the same line the makers of these appliances would soon begin to do a bit of useful thinking. Similar reports from representative after representative would eventually have their effect.

Non-interfering!

Just as I'd written that last paragraph a card was brought in to me with the information that its owner was very anxious to see me, as he had something special to display. A vacuum cleaner man! As he pencilled on the card "Does not affect wireless sets," I saw him. He was most anxious that I should make a practical test, so I switched on a set, bidding him put his cleaner together. He finished assembling the bits and pieces, plugged in and switched on. A

noise like that made by a squadron of aeroplanes all but drowned the London Regional programme! "There you are," said he. "W-w-where?" I gasped. "You see," he explained, "it does not stop the set working." He had apparently the idea that interference meant something that put the set right out of action! As kindly as possible I disillusioned him. Then I led him to a distant room, switched on a set there and let him hear what his infernal machine could do at long range—the second set is 80ft. from No. 1 and connected to another aerial. At that moment my next-door neighbour came in to ask if I could

render first aid to his receiver, which had gone mad and was emitting horrible noises. The vacuum cleaner merchant left, a sadder and (I hope) a wiser man.

Not the Food of Love

THE other evening, when I was endeavouring to do some work, my ears were assailed by appalling strains of mangled music. The noise sounded rather like that which used years ago to be produced at times when some enthusiast was proudly demonstrating to a friend the marvellous volume of which his set (five "R"

valves and a horn loud speaker!) was capable. At first I thought that one of my neighbours had installed some atrocity and was giving it a trial "all out" run. Then I realised that a fair was being held in a field about a quarter of a mile from me. The modern showman has discarded the steam organ in favour of pick-up, turntable and a public-address amplifier with rather awful results. His clients like a lot of noise, so he turns the volume control right up and lets things rip. A distant steam organ did not sound beautiful; but it was sweetness itself in comparison with an overloaded PA outfit blaring out jazz!

DIRECT RECORDING BLANKS

Compiled by Donald W. Aldous

In the May 19th, 1938, issue of "The Wireless World" a Table of direct play-back blanks for sound-recording was published, which was prepared by the present writer. Below is a revised version of this Table of blanks which are all readily obtainable in this country. Details of foreign blanks are not included, but a list of the names and addresses of the principal blank manufacturers abroad is appended.

Abbreviations: SS = Single-sided. DS = Double-sided.

Name	Type		Diameter	Prices Retail Each.	Manufacturer or Main Stockists.	
	Base	Surface Coating				
Decelith...	Unbacked (flexible).	Non-inflammable material.	Polishing fluid only	8in. (DS)	2s. 0d.	Will Day, Ltd., 19, Lisle Street, W.C.2.
				10in. "	2s. 6d.	
				12in. "	4s. 0d.	
Electradix ...	Aluminium alloy	—	Before cutting a lubricant may be applied, e.g., paraffin oil or olive oil, or "Vaseline."	6in. (DS)	3s. 3d. (doz.)	Electradix Radios, 218, Upper Thames Street, E.C.4.
				10in. "	7s. 0d. "	
G. C. Master ...	Zinc	Cellulose acetate	None	10in. (SS)	1s. 8d.	G.C. Electrical Recording Co., Ltd., 181, Wardour Street, W.1.
				12in. "	2s. 8d.	
				10in. (DS)	2s. 6d.	
				12in. "	4s. 0d.	
				13in. "	4s. 9d.	
Neo-Cire ...	Metal	Cellulose compound	Electrolytic, as these blanks are primarily intended for use as masters when solid stock pressings required.	11in. (SS)	4s. 0d.	V. G. Manufacturing Co., Ltd., Gorst Road, Park Royal, N.W.10, and Makers' Agents, Agents, Ltd., High Holborn House, High Holborn, W.C.1.
				13in. "	5s. 0d.	
Phono-Disc ...	Aluminium ...	Non-fluid chemical lubricant impregnated in surface of aluminium.	None	6in. (DS)	5s. (doz.)*	Phono-Disc Ltd., 65, Bolsover Street, W.1.
				10in. "	10s. "	
				12in. "	20s. "	
Presto	Aluminium ...	—	Usual cutting lubricant, if desired	6in. (DS)	Prices not available price schedule under revision.	A. C. Clifford, 17, Wigmore Street, W.1.
				8in. "		
				10in. "		
				12in. "		
				16in. "		
Presto	Aluminium Thick (Green Seal)	Cellulose compound	Preserving fluid, known as "Disclube" is available.	6in. (DS)	"	"
				8in. "		
				10in. "		
				12in. "		
				16in. "		
Presto	Aluminium Thin (Orange Seal)	" " "	" " " " " "	6in. (DS)	"	"
				8in. "		
				10in. "		
				12in. "		
Pyrat	Cardboard ...	Cellulose compound	—	6in. (DS)	8d.	V. G. Manufacturing Co., Ltd., Gorst Road, Park Royal, N.W.10, and Makers' Agents, Ltd., High Holborn House, High Holborn, W.C.1.
Pyrat	Zinc	Cellulose compound, plus black varnish	None, although a hardening or polishing fluid may be used if desired.	8in. (DS)	10d.	
Pyrat	Aluminium ...	" " "	" " " " " "	10in. (DS)	1s. 6d.	
Simplat	Unbacked, flexible.	Gelatinous composition (non-flam.)	Chemical treatment, i.e., hardened and polished by fluids containing formaldehyde and waxy oils respectively.	10in. (DS)	3s. 0d.	V.G. Manufacturing Co., Ltd., Gorst Road, Park Royal, N.W.10.
				12in. "	4s. 0d.	
				14in. "	6s. 0d.	
				16in. "	8s. 0d.	
Supercut ...	Aluminium ...	Cellulose acetate (Black coloured).	Chemical treatment, if desired, and very light oil applied before and after cutting will prolong useful playing life.	10in. (SS)	2s. 8d.	M.S.S. Recording Co., Ltd., 83, The Green Kew, Surrey.
				12in. "	3s. 0d.	
				13in. "	5s. 0d.	
				10in. (DS)	3s. 6d.	
				12in. "	4s. 6d.	
				13in. "	7s. 0d.	
W.D.	Metal	Cellulose acetate	Polishing fluid only	8in. (DS)	2s. 0d.	Will Day, Ltd., 19, Lisle Street, W.C.2.
				10in. "	3s. 0d.	
				12in. "	4s. 6d.	

* (Phono-Disc) Smaller quantities are not supplied at proportionate prices.

FOREIGN BLANK SUPPLIERS.

- 1) Allied Recording Products Co., 126, West 46th Street, N.Y.C., U.S.A.
- 2) Cellutone Record & Mfg. Co., Los Angeles, California, U.S.A.
- 3) Mirror Record Corporation, 58, West 25th Street, N.Y.C., U.S.A.
- 4) Presto Recording Corporation, 242, West 55th Street, N.Y.C., U.S.A.
- 5) Rangertone Inc., 201, Verona Avenue, Newark, New Jersey, U.S.A.
- 6) Recoton Corporation, 178, Prince Street, N.Y.C., U.S.A.
- 7) Sound Apparatus Co., 150, West 46th Street, N.Y.C., U.S.A.
- 8) Svenska Radioaktiebolaget, Abströmekgatan, 12, Stockholm, Sweden.
- 9) Universal Microphone Co., Ltd., Recording Division, Inglewood, California, U.S.A.
- 10) Wiener Gelatinewaren Industrie, XVII/3, Hernalser, Hauptstrasse, 130, Vienna.

Recent Inventions

RELAYING TELEVISION SIGNALS

TO maintain the correct balance as between the high and low frequencies in a transmission line for relaying television signals, attenuation losses are compensated by deliberately increasing the amplitude of the high-frequency components at the input to the line, and then reducing them to their proper proportion at the output end of the line.

At the input, the signals are subjected to a process of double modulation and are passed through "distorting" circuits which make the desired frequency discrimination, the process being reversed as the currents are delivered from the far end of the line to the local amplifiers. The overall or resultant distortion is thus reduced to zero, both as regards phase and frequency.

Standard Telephones and Cables, Ltd.; K. G. Hodgson; and W. N. Roseway. Application date July 21st, 1937. No. 499317.

TUNING CONTROL

WHEN a receiver is fitted with automatic tuning control, it is difficult to tune in to a weak station that happens to be adjacent to a strong station, because the ATC action tends to "pull" the circuits into tune with the dominant station. One way of overcoming this difficulty is to provide a switch for cutting-out the ATC action when searching for a relatively weak signal.

The figure shows a convenient arrangement in which the ATC is maintained operative for relatively

Brief descriptions of the more interesting radio devices and improvements issued as patents will be included in this section.

strong signals, but is automatically cut out of action when tuning the set to a weak signal. In the latter case, for instance, the normal AVC bias gives the IF valve V a low impedance, so that sufficient current flows through the cathode resistance R to energise a relay K. The lower pair of contacts C are thus closed to short-circuit the ATC voltage across the leads L. Tuning is then completed by hand control.

For a strong signal, the impedance of the valve V is increased by the AVC bias, the relay K is de-energised, and an upper contact C1 is closed to energise a winding W. This puts a braking action on the movement of the tuning spindle S through a disc D, and so warns the operator to release the tuning knob T, so that the ATC voltage can complete the tuning.

E. K. Cole, Ltd., and A. W. Martin. Application date September 18th, 1937. No. 501934.

LARGER PICTURES

RELATES to a cathode ray television receiver of the kind in which an image of the televised picture is projected through a screen of variable transparency on to a large viewing screen mounted outside the tube.

As shown, the electron stream from the gun G is made to scan a screen S in the usual way. Instead of being fluorescent the

screen S is composed of a transparent substance capable of developing static charges under the action of a scanning stream. Mounted immediately behind it is a shallow disc-like chamber C filled with paraffin oil containing a large number of iron particles in solution.

Normally the iron particles arrange themselves indiscriminately, and in this condition they block the passage of a ray of light

be used for the "robot" control of an unmanned aeroplane.

The indicator is fed with signal voltage picked up on a frame aerial and combined alternately in and out of phase with the pick-up from a non-directional aerial. This gives a reversed cardioid curve, the necessary phase-changing being effected by a motor-driven switch.

Marconi's Wireless Telegraph Co., Ltd.; and T. A. Vallette. Application date September 4th, 1937. No. 501550.

MOSAIC SCREENS

A KNOWN method of producing television signals is to project a picture on to a mosaic screen

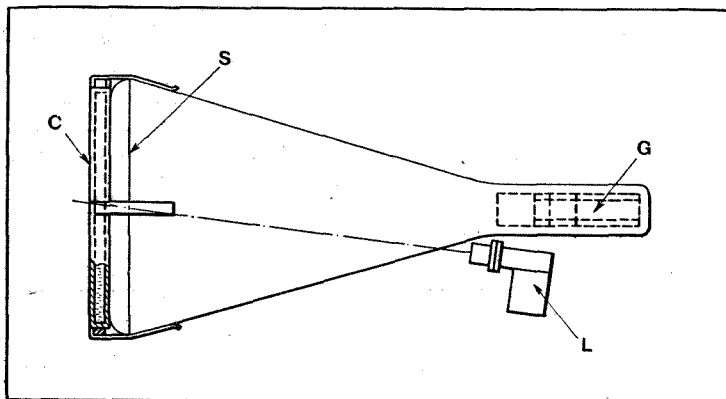

Projection-type cathode-ray tube for large television pictures.

from a powerful lamp L. But under the action of the scanning beam—which sets up local static charges on the screen S—the iron particles are aligned "end-on" to the screen, and so permit the free passage of light from the lamp L to an extent varying with the intensity of each picture point.

This allows an image of the picture to be projected from the lamp L, through the paraffin, on to a large-sized viewing-screen which can be mounted outside the tube.

F. J. G. Van den Bosch. Application date September 3rd, 1937. No. 501816.

DIRECTION FINDERS

IN an automatic direction-finder for "homing" on to a beacon station, the bearing-line is indicated by the point of intersection of two separate pointers which move over a dial marked with a series of radial lines diverging from a common centre. When the machine is flying "on course," the pointers intersect on the centre-line, the pointers gradually travelling down and along it as the machine approaches the transmitter.

This avoids having to use any critical degree of AVC to compensate for varying field strength in the course of the flight. The same kind of indication is given along an inclined radial line, when the beacon station is to port or starboard of the machine. Used in conjunction with a compass, the arrangement gives a reliable indication of wind drift. It can also

be used for the "robot" control of an unmanned aeroplane. The indicator is fed with signal voltage picked up on a frame aerial and combined alternately in and out of phase with the pick-up from a non-directional aerial. This gives a reversed cardioid curve, the necessary phase-changing being effected by a motor-driven switch.

According to the invention, this distortion effect is prevented by constructing the mosaic screen so that it has a variable instead of a uniform sensitivity, both as regards photo-electric response and the production of secondary electrons. The screen usually consists of a silver plate with an oxidised surface, and the required effect is obtained by shading-off the degree of oxidation from the centre towards the edges of the plate.

W. Heimann. Convention date (Germany) September 10th, 1936. No. 502024.

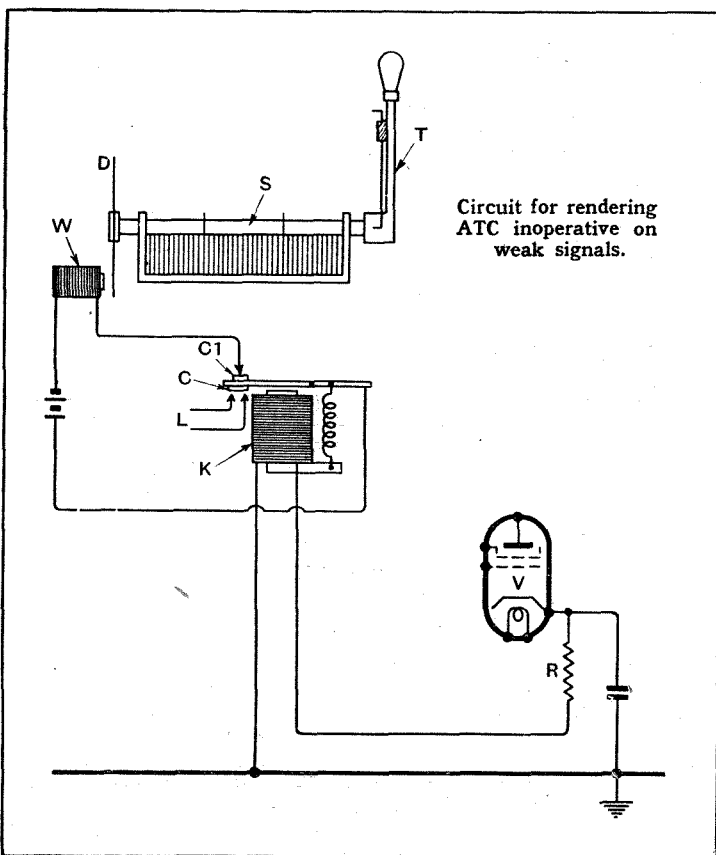

The British abstracts published here are prepared with the permission of the Controller of H.M. Stationery Office, from specifications obtainable at the Patent Office, 25, Southampton Buildings, London, W.C.2, price 1/- each.

The Wireless World

THE
PRACTICAL RADIO
JOURNAL
29th Year of Publication

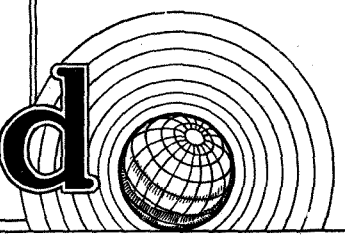
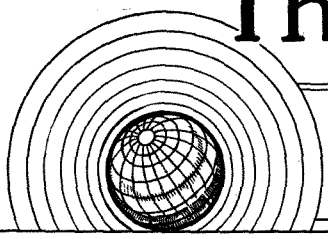

No. 1030.

THURSDAY, MAY 25TH, 1939.

VOL. XLIV. No. 21.

Proprietors : ILIFFE & SONS LTD.

Editor :
HUGH S. POCKOCK.

Editorial,
Advertising and Publishing Offices :
DORSET HOUSE, STAMFORD STREET,
LONDON, S.E.1.

Telephone: Waterloo 3333 (50 lines).
Telegrams: "Ethaworld, Sedist, London."

COVENTRY: 8-10, Corporation Street.
Telegrams: "Autocar, Coventry." Telephone: 5210 Coventry.

BIRMINGHAM:
Guildhall Buildings, Navigation Street, 2.
Telegrams: "Autopress, Birmingham." Telephone: 2971 Midland (5 lines).

MANCHESTER: 260, Deansgate, 3.
Telegrams: "Iliffe, Manchester." Telephone: Blackfriars 4412 (4 lines).

GLASGOW: 26B, Renfield Street, C.2.
Telegrams: "Iliffe, Glasgow." Telephone: Central 4857.

PUBLISHED WEEKLY. ENTERED AS SECOND CLASS MATTER AT NEW YORK, N.Y.

Subscription Rates :
Home and Canada, £1 10s. 4d. ; other countries, £1 12s. 6d. per annum.

As many of the circuits and apparatus described in these pages are covered by patents, readers are advised, before making use of them, to satisfy themselves that they would not be infringing patents.

CONTENTS

	Page
Editorial Comment	479
Aerial Masts : Practical Hints on Design and Construction	480
Cathode-ray Oscilloscope	483
Problem Corner	486
Television Programmes	486
Footless Valves	487
News of the Week	489
AF Transformers Simplified	491
"The Wireless World" DC Mains Super : Construction and Adjustment	493
McMichael Model 382 : Test Report	496
Club News	497
Unbiased	498
The B.B.C.'s German News Bulletins	499
Letters to the Editor	500
Random Radiations	501
Recent Inventions	502

EDITORIAL COMMENT

Suppression of Television Interference "We've Got to be Prepared"

THE British Standards Institution has recently issued a "Specification for Radio-interference suppression for Automobiles and Stationary Internal-combustion Engines." This is the fifth technical specification dealing with radio interference to be issued by this Institution. The preparation of all these publications represents an enormous amount of time and effort devoted not only by the Institution itself but by the representatives of the numerous co-operating organisations.

In issuing this new specification, the B.S.I. states that "it must not be inferred from the publication of the specification that all motor cars will immediately be fitted by the makers with suppression devices. In the event of relevant legislation coming into force, however, the guidance given in the specification will be of considerable assistance to the industry, and in the meantime car owners and designers will find much in the specification to interest them."

Wasted Effort

It seems to us an extraordinary state of affairs that so much work should have been undertaken before there was any guarantee that it would ultimately serve a useful purpose. At present it is to be regarded as of "interest" to car owners and designers but it will only become of practical value "in the event of relevant legislation coming into force."

We have often expressed the view that it would be expecting too much to hope that manufacturers generally would go to the trouble and cost of

fitting suppressing devices to interfering sources unless it becomes compulsory to do so, nor do we think it fair that any manufacturer should be asked to take such action on a voluntary basis whilst his competitors may decline to do so.

If suppression is to be effective it must be made compulsory, yet the years go by and no progress in this direction is apparent. As time goes on the complexity of the problem of legislation increases.

Is it not time that the matter should be reviewed to see if it is not possible to introduce some simple form of legislation which will render interference in principle illegal without waiting for the evolution of an ideal and comprehensive statute? We should then justify the work of the B.S.I. on the principle that "we've got to be prepared."

B.B.C. Statements

Quote the Authority

ON another page we print a letter from a correspondent who, though not completely in agreement with our views, expressed in a recent issue, on B.B.C. news bulletins, is clearly with us in believing that the source of Government-inspired statements should be given. In this matter we would indeed go farther than our correspondent, and urge that the origin of every statement should be made clear. This rule should apply even to the admittedly trivial and often innocuous items that are often broadcast in such a way as to suggest that they emanate from the B.B.C. itself. The fact that the Corporation appears sometimes to assume the responsibility of admonishing its listeners has surely done much to incalcate in simple minds the idea that it is speaking with Government authority.

Aerial Masts

PRACTICAL HINTS ON DESIGN AND CONSTRUCTION

By R. H. WALLACE

WHEN one has taken considerable trouble in the erection of mast and aerial, it is very disappointing to find the whole brought down by some extra-strong gale, yet there are many points to be considered if this is to be avoided. In the present article only the more ordinary types of receiving aerial and mast will be considered, and the formulæ and calculations will be omitted, enough data being given to enable reasonable alterations to be made to the typical designs set out, while at the same time the various factors affecting the strength and endurance of the mast will be indicated.

The first step in the actual design of an installation is a decision on the type and dimensions of the conductor; this may seem to be the wrong end to start at, but, in fact, it is only when this has been done that it is possible to evaluate the horizontal pull on the mast, which must be known before the necessary strength of the top section in particular, and the structure as a whole, can be determined. Since the more ordinary types are here being discussed, there will in general be one or two wires only, the total length being limited by the G.P.O. regulations and by the space at one's disposal. There will not usually be more than 70ft. or so of single, or about half this length of double, conductor, so that the weight and wind loading will be about the same for the two. This length is accordingly the longest that will be considered, and it can be taken that where double wire is used it will be precisely equivalent to twice the length of single wire so far as the effect on the pole is concerned.

Choice of Wire

The size and material of which the conductor is made do not admit of much variation, as for such short spans the strength of hard-drawn copper wire is more than sufficient. This will, therefore, be the obvious choice on the grounds of its superior conductivity. The minimum cross-sectional area is fixed by the tensile stress it may be called on to bear, which should not be allowed to exceed 30,000 lb.

per sq. in. The stresses are dependent on several factors, one not often recognised as important by the amateur being actually the most likely to cause failure, namely, the stress due to the weight of the wire. Some readers may call to mind the well-worn maxim, "No power on earth, however great, can stretch a cord, however fine, into an horizontal line which shall be absolutely straight. The stress increases very rapidly as the sag becomes small, and, unless a sufficient amount of this is left when erecting, the wire may break should temperature changes or ice formation cause additional stress.

A good practice is to leave a sag of from two to four per cent. of the span, the smaller figure if the erection be performed

WHILE most readers are likely to possess a good knowledge of the electrical properties of aerials, it is probably true to say that comparatively few have full knowledge of mechanical design and construction. This article treats of this aspect of the subject, and deals with the erection of both steel and wooden masts. Detailed constructional information is given for masts of various heights and diameters.

on a cold, frosty day, and the latter if the day be warm. With a sag of two per cent. the pull on the supports will be about six times the actual weight of the wire. This is not an over-cautious figure; indeed, if this were all, the design would be a very simple matter. Actually, if this figure alone were taken into consideration when designing the mast, then it would almost certainly collapse when sleet and frost produced a coating of ice on the conductor. The weight of such a coating is not easy to estimate, but, fortunately, we can profit by the experience of others with transmission and telephone lines. These are usually designed on the assumption that they may have to bear an additional loading equal to that due to a radial thickness of $\frac{1}{4}$ in. of solid ice. Coatings much

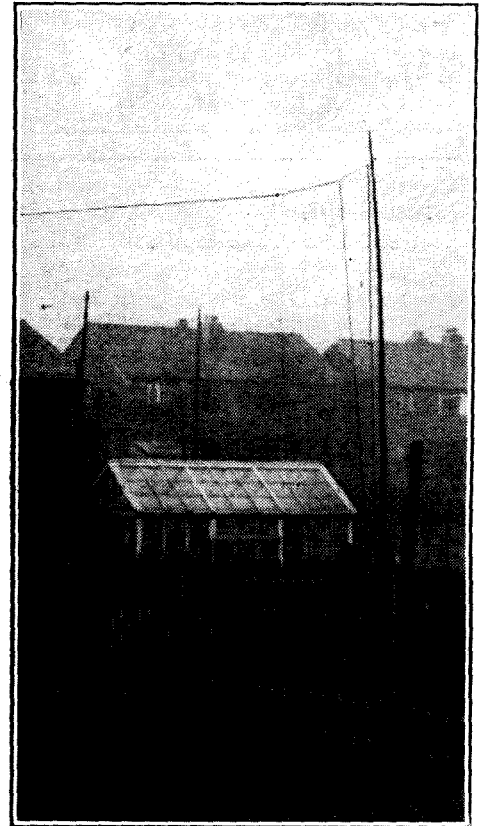

The effect of using an unduly thin mast without guys to counteract the wire pull is clearly visible in the case of the foreground mast.

thicker than this do occur, but they are rarely as dense as solid ice, and this figure makes all the allowance that is necessary. This extra loading due to ice may make the pull on the mast several times greater than before, and the necessary allowance must be made, together with those for the other stresses. It should be noted, however, that by increasing the sag sufficiently it is possible to reduce the stress to any desired value above the weight of the wire, but this is hardly worth while, as the side pressure on the mast due to gales may reach as high a figure as the stress due to ice loading at two per cent. sag.

Wood or Steel?

Table I, showing the pull due to a sag of this amount, with different spans, and for two common sizes of wire, is included to show the great effect this factor has on the design of the mast. Calculations show that, for a span of 70ft., the tensile stress approaches the safe maximum for 7/26 copper wire; there is, however, no reason why this should not be used, though the use of 7/22 will give a greater factor of safety, and is recommended by the writer for all spans over 40ft. It should be noted that the use of insulated wire will result in the stress under ice conditions becoming much greater than is the

TABLE I

Horizontal Pull with Various Spans of Copper Wire with a sag of 2 per cent. (in lb.)

Size of wire	Span of Conductor					Remarks
	30ft.	40ft.	50ft.	60ft.	70ft.	
7/22	3.1	4.1	5.2	6.2	7.3	Normal.
7/22	22.8	30.6	39.2	45.8	53.6	With $\frac{1}{4}$ in. radial thickness of ice.
7/26	1.3	1.7	2.1	2.5	2.9	Normal.
7/26	19.6	26.4	33.6	39.4	46.2	With $\frac{1}{4}$ in. radial thickness of ice.

Aerial Masts—

case with bare wire, as, among other things, the diameter is larger. In practice it has been found that the use of 7/26 insulated wire cannot be advocated for spans over 30ft., and it is, in the writer's opinion, just as satisfactory to use bare wire.

In this article attention is being confined to tubular steel masts and their wooden equivalents, and the first point to be decided is which to use. There is not any overwhelming advantage possessed by one or the other, and the question has to be settled mainly on the score of relative cost and availability. The wooden pole is cheaper and often more easily available, it has grown to withstand much the same sort of stresses as are now required of it, and has a naturally correct taper; also its ability to bend through considerable angles without damage is in its favour. On the other hand, wood has undoubtedly a shorter life than a properly protected steel mast, and larger factors of safety have to be allowed in the case of the former, since the presence of defects of uncertain magnitude is always probable. The steel mast is capable of an indefinite life if properly protected, and there is less uncertainty about its strength, nor will this be likely to depreciate greatly during its life, as is the case with wood. Steel tubes are not readily available in the lengths which are likely to be required, however, and there is the problem of jointing to be considered; also tapered tubes are not within the realm of economical manufacture for this purpose, and two or more diameters will have to be used, since the bending moment increases as the base of the pole is reached.

Methods of Staying

Self-supporting masts have the merit of neatness, and, if properly erected, are very attractive, but they have the disadvantage that they need to be much stronger, and also there is no means of counteracting the pull of the wire, with the result that they can never be quite straight at the top. The greatest difficulty lies in their erection and in the maintenance of vertical alignment. In general, they are more costly and more difficult to erect, but there are many circumstances where their other good points outweigh these drawbacks, and they may be adopted with success.

A compromise between the entirely unstayed and the fully guyed mast can be made by using spreaders at the middle of the pole, guy wires being attached at the top and brought over these to the foundation of the mast. This arrangement avoids the necessity of a large piece of ground, and, since in many cases it is desired to take advantage of the full length of garden available, enables the use of a longer aerial without having to fix stays on other people's property.

The pull on the top is not the only stress the mast has to bear; it must be strong enough not to break in erection, when the weight is largely borne by the section

nearest the base, while there is the wind pressure on the pole itself to be allowed for, besides that on the wire. Calcula-

domestic sort, the service stresses will be greater than those encountered in the course of erection, so that if it is strong

TABLE II
Recommended Maximum Lengths of "Steam Quality" Tube, free and with various Spans of 7/22 copper wire at 2 per cent. sag, and with 1/4 in. radial thickness of ice.

Nominal size of tube, in.	Outside diam. of tube, in.	Maximum length in feet	Tube lengths with aerial spans as under					Length of lower tube in feet (see note)
			30ft. in feet	40ft. in feet	50ft. in feet	60ft. in feet	70ft. in feet	
1	1.309	17	8	6 1/2	5 1/2	4 1/2	4	—
1 1/4	1.650	22	13 1/2	11 1/2	10	9	8	—
1 1/2	1.892	24	16	14	12	11	10	—
1 3/4	2.116	25	18	16	14 1/2	13	12	—
2	2.347	26	18 1/2	17	16	15	14	12
2 1/4	2.587	28	—	—	—	—	—	13
2 1/2	2.960	32	—	—	—	—	—	14

Note.—Length when carrying the maximum length of tube 1/4 in. smaller in diameter.

tions show that, in the sizes likely to be used for receiving installations of the

enough to bear the former under the worst conditions, there will be no likelihood of failure. It might be added that the weather conditions envisaged in the designs that follow are those probable in the British Isles, but it must not be forgotten that there are some places where these assumptions will not be valid and would result in too low a factor of safety.

Jointing Steel Masts

The wind pressure, at normal heights, may be as high as 50 lb. per sq. ft. of projected section, but an allowance is usually made for round objects by taking half of this, and since the above conditions are very exceptional it will be sufficient if the maximum pressure on a round spar is taken as 15 lb. per sq. ft. This makes the total side-thrust on a pole, 30ft. high and 2in. in diameter, equal to 75 lb. weight, a very considerable value indeed, and one that cannot be neglected.

In the design of a steel mast one is usually restricted to the standard sizes obtainable from stock, and it may be useful to give some indication of these; seamless tubes are expensive and not normally available, and the most convenient source of supply is those welded tubes, which are made for gas, water and steam, and are used for plumbing installations and the like. Those intended for carrying steam usually have thicker walls than gas or water pipes. Standard fittings, such as coupling sockets, caps, flanges and various pieces for joining several tubes together, are readily bought, and from these can be assembled most of the necessary types of mast; at a slight additional cost these may all be had in a galvanised finish, which is well worth while even if the whole is to be painted, and is essential if this is not the case.

The jointing, which will be necessary at least once in the height, may be done either by driving one tube into the other so that they overlap about 6in., using a piece of sheet metal to make the fit correct, or by the use of screwed couplings. The latter method is easier, but has the disadvantage that the section of the tube at the joint is reduced by the threading, and it is therefore necessary to use one thickness greater in order to allow for this. In either case it is wise to sweat over the joint

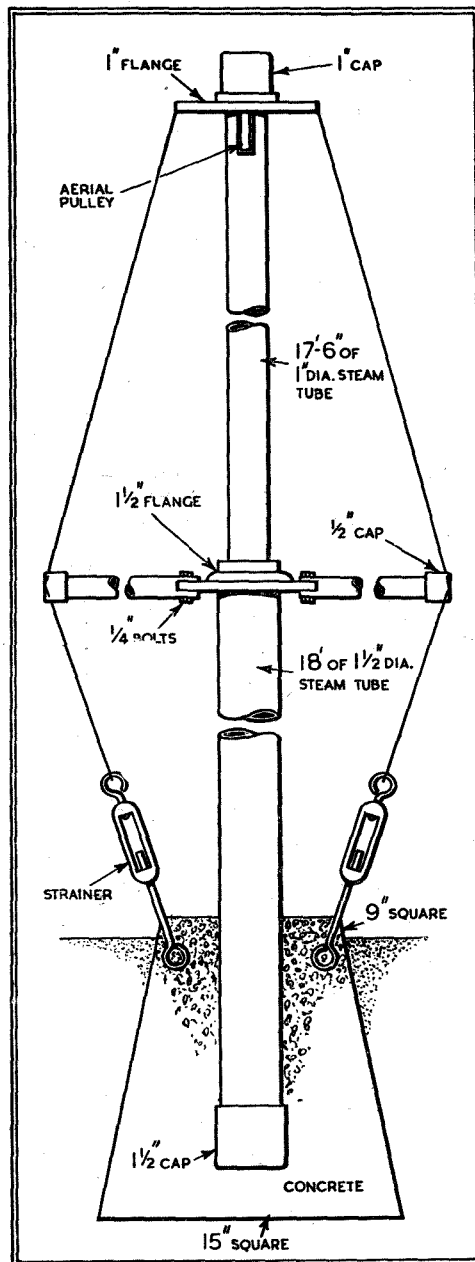

A compromise between the unsupported and the fully-stayed mast can be made by stretching stays of 7/20 SWG galvanised steel wire from the top of the mast to the base, passing en route through a slot cut in the outer end of spreaders attached radially to the centre of the mast. Three spreaders and stays, spaced at an angle of 120 degrees to each other, are used.

Aerial Masts—

with solder so that no moisture can gain admittance and cause corrosion and subsequent failure. This is especially necessary with galvanised tubes, where there exists the possibility, in certain circumstances, of electrolytic action. This may be prevented by a coat of paint. Steam and water tubes are sometimes not readily obtainable galvanised, and these should have at least one coat of good paint over the somewhat indifferent coating put on by the manufacturers. This painting should naturally be done after assembly of the mast and before erection.

The full calculations necessary to ascertain the stresses in the mast and guys are out of place here, and, instead, tables are given which will facilitate the adoption of designs other than the standard. Table II gives the maximum recommended lengths of the various sizes of steam tube, both without any pull due to the wire and also with different spans of 7/22 copper. The probable wind pressures on pole and wire with the additions for ice loading have been taken into account and a reasonable factor of safety allowed. These figures refer to an unsupported mast, and give the permissible length of the top section. To cover the requirements of the lower parts the last column is included; this shows the length of tube which can safely support the full length of a top section $\frac{1}{2}$ in. smaller in diameter than itself, *i.e.*, if the top part is 1 in. nominal, then the next one should be $1\frac{1}{2}$ in., and the length may be 12 ft. Similarly, if three sections are required, then the lowest of them may be a 12 ft. length of 2 in. diameter. It should be noted that the part in the ground is not included in the above, and this may be added to the bottom tube without increasing the stress.

Securing the Base

Where lengths greater than those thus shown are needed, it is clear that stays will have to be used; also, if more than two sections are included it is wise to run guys to each junction. In these cases the lengths may safely be increased to the figures given for a free tube of the appropriate size. The amount of the tube that should be below the ground is a great deal affected by the nature of the latter; it is smallest for good clay and greatest for sandy soils. It is also dependent on the size of the mast, and is greater for steel than wooden poles, as the latter have a smaller diameter at the base. A very usual allowance is a depth of setting equal to one-fifth of the height above ground; somewhat less than this may be permitted for guyed masts in good soil, but where the unsupported and small-base types are used, the full amount should be allowed. Even for wood masts in poor ground this will be insufficient, and a concrete foundation, at least six inches square at the top, should be provided to distribute the pressure better. Unless these precautions are taken the mast will, sooner or later, begin to lean, and there are few things more unsightly than this. Alternatively,

in the case of wood poles, kicking blocks may be used. These are blocks fitted crosswise to the mast at the butt and just below ground level so that they help to take the bending action of the wire-pull, and thus prevent movement. For steel masts which are not guyed in the conventional manner, it will be necessary to use a concrete base, and in soft soil it would be a wise precaution even with a well-stayed mast; it has, too, the advantage that it protects the base of the tube from corrosion.

Where normal guying is adopted the wires must be anchored in the ground and, though this may be done by driving stakes into the earth and attaching the stays to these, a much better way is to fasten them to plates or boards buried in the soil at a depth of, say, 4 ft.; at this depth a plate 1 ft. square will hold any pull that is likely to be experienced. In order to ensure that the guys are tight it is

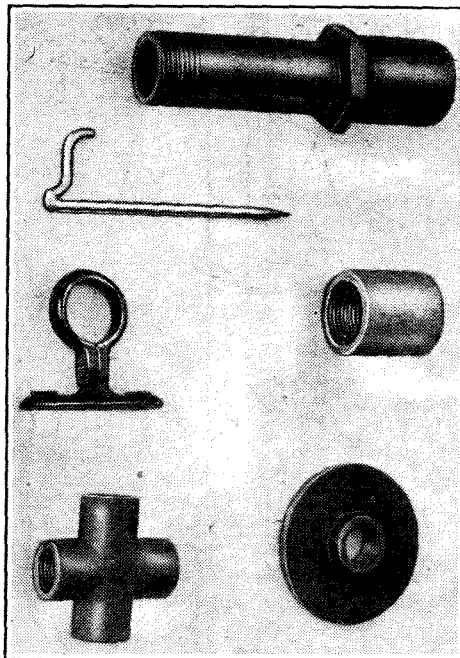

Fittings for masts showing tube with coupling sleeve and locking nut, wall hook, cap, clip for screwing on wood, crosspiece and flange.

best to fit screwed strainers a short distance above ground; the slack may then be taken up with precision. For the small-base type of construction it is necessary to fix the stays near, but not to, the base of the mast, and since this type will have a concrete foundation, it is easy, when pouring the latter, to arrange to embed suitable hooks, or the lower end of each strainer, therein. When attaching the guys to steel masts a standard flange is useful. This may be drilled to take the aerial pulley also, and then screwed on to the top of the pole before fitting the cap. Where stays have to be fixed to the joint of the tubes this is also the neatest way of doing the job. A flange is also useful at the bottom of the mast to increase the area where this would otherwise sink in soft ground. If a concrete foundation is not used the bottom of the tube should be closed with a cap to lessen corrosion.

In Next Week's Issue

SHORT-WAVE COILS. Design and constructional data for efficient windings.

VOLTAGE-CURRENT RELATIONSHIPS. Simplifying points in AC theory that often cause confusion.

TRANSMITTER MEASUREMENTS. Constructional details of a valve voltmeter and methods of using it.

Where it is required to fit spreaders at the centre of the mast, this may be done by the use of a flange having lengths of, say, $\frac{1}{2}$ in. tube fixed to it as shown in the diagram. As these are always in compression there is little tendency for them to slip even if the bolts shown are omitted, but these are an additional precaution and are recommended; a cap should be fitted to the ends of these pieces of tube and a groove filed in this to locate the wire. In the case of wooden masts such struts should be at least $1\frac{1}{2}$ in. square and may be secured to the pole by small rectangular brackets, such as are used to support shelves.

The number of guys may vary from the single one, used where it is desired merely to counteract the bending of the top section in an unsupported mast, to four or more, but the writer advises the use, where possible, of three, set at an angle of 120 degrees to each other and with the aerial wire opposite to one of them. By the adoption of this construction the mast is fully stayed and does not depend on the aerial, which may break, to offset wind pressure. The stays should be strained a little when erection is complete, but not to an excessive amount, or the whole system will be too rigid; if they are so tight that they "sing" nicely at a low pitch the stress will be about right. This also gives a means of ensuring that all are equally loaded as, being the same length, they should give the same note.

(To be concluded.)

BOOKS RECEIVED

Building a Television Receiver at Home. Pp. 112. Published by Bernard Jones Publications, Ltd., 37-38, Chancery Lane, London, W.C. Price 2s. 6d.

Constructional details are given in this booklet of television receiving apparatus for 1-in., 4-in., and 12-in. tubes of the electrostatic type. The contents are reprinted, with revisions, from *Television and Short-wave World*.

Radio Marketing Trade Annual, 1939. The information contained in this book of reference is grouped under three main headings: Directory, Technical, Commercial and Legal. It contains a list of wireless firms, a "Who's Who," business information for dealers and others, while, in the technical part of the book, there is a new television servicing section. The annual costs 5s., post free, and is published by *Radio and Electrical Marketing*, 29, Bedford Street, Strand, London, W.C.2.

Cathode-ray Oscilloscope

SIMPLE UNITS EMPLOYING A 2½in. TUBE

THE modern trend is more and more towards the use of the cathode-ray tube for testing purposes, and an oscilloscope is undoubtedly an extremely versatile and robust piece of apparatus. Its great advantage is that it gives a two-dimensional response so that it indicates the combined effect of two voltages.

For many purposes the cathode-ray tube with its power supply is sufficient, but for others a linear time-base is necessary. The apparatus described in this article is consequently built in two units, thus giving a maximum of flexibility. Before discussing the applications of the apparatus, it is advisable to have some idea of what it is, and we shall accordingly deal with this first.

The circuit of the CR tube unit is shown in Fig. 1. The tube used is the Osram 4081 with a diameter of 2½in. The screen colour is green. It is a two-anode tube with an indirectly-heated cathode, and all four deflector plates are brought out for external connection.

The HT supply is provided by a full-wave rectifier in the conventional manner, the reservoir condenser C1 having a capacity of 8μF. Owing to the low current consumption it is possible to dispense with a smoothing choke and to use a

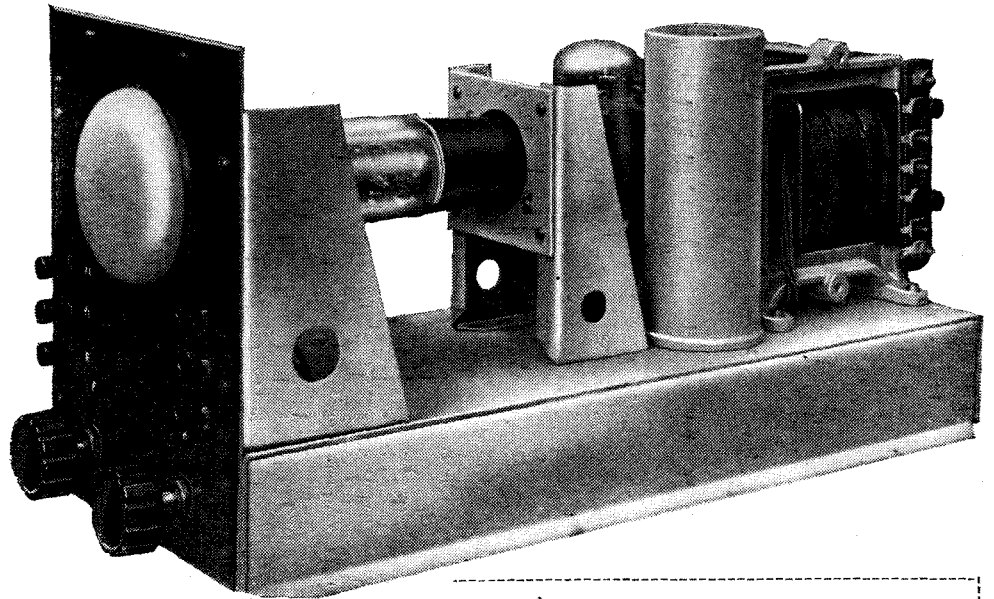

A view of the tube unit; the mains equipment is at the rear.

Fig. 1. — This diagram shows the circuit of the tube unit with its HT supply.

THIS versatile equipment meets the basic applications of the small CR tube for test purposes. It is easy to build and, being arranged in unit form, construction need only be carried as far as the particular requirements demand. Many industrial applications of the CR tube preclude the use of a ready-built unit and trouble may be saved by working to this clearly set out design.

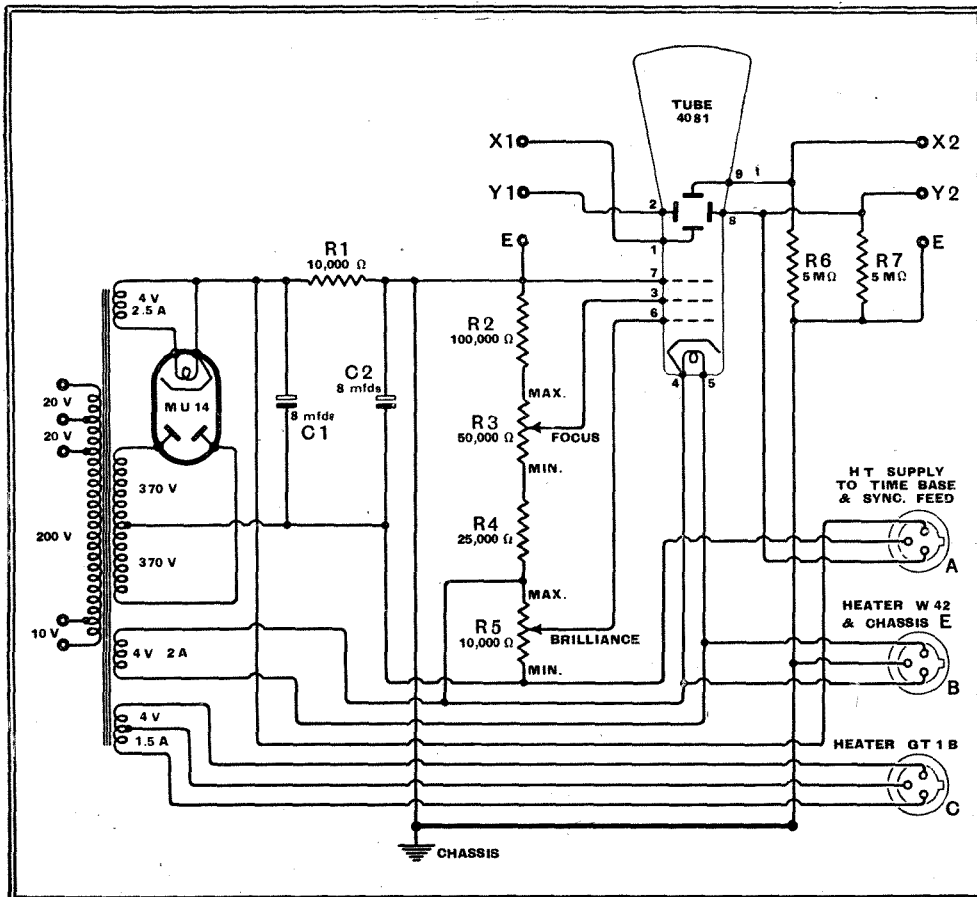

10,000-ohm resistance R1 instead. The smoothing condenser C2 is 8μF.

Positive HT is taken directly to the second anode of the tube, and the other electrodes are connected to tapings on a potentiometer across the HT supply. This comprises R2, R3, R4 and R5. The first anode is fed from the slider on R3 since the potential required is critical for focusing. R3 thus forms the focusing control. The cathode is connected to the junction of R4 and R5, and the grid is taken to the slider on R5, so that it is negative with respect to the cathode. The bias is adjustable to form a brilliance control.

The HT supply is taken to an output socket so that it can be fed to the time-base unit if this is employed. Heater windings are also provided on the mains transformer for this unit.

It is important to note that the *positive* HT lead is earthed to the chassis. This is done because the deflector plates must be returned to the second anode, and they are at earth potential since they must be available for connection to external circuits.

Two of the deflector plates are taken to the terminals X1, Y1, and the other two are taken to the terminals X2, Y2, and are

Cathode-ray Oscilloscope—

also connected to the second anode through the 5-megohm resistances R6 and R7. In use there must always be a conductive path between X₁, Y₁ and E. Normally these three terminals are connected directly together, and if they are not, then resistances must be interposed between X₁ and E and between Y₁ and E.

The output of the rectifier is some 400 volts, and the potentiometer across the HT supply takes 2.2 mA. The first anode potential is variable from about 50 volts to 160 volts, and up to 22 volts bias is available. The second anode potential with respect to cathode is 378 volts.

The deflection sensitivity is approximately 0.397 mm. per volt or 0.156 in. per volt. For a deflection of one inch some 64 volts is thus needed, or for one centimetre 25 volts. This is for a steady potential applied between X₁, X₂ or Y₁, Y₂. With an alternating potential the deflection depends on the peak-to-peak voltage which is 2.828 times the RMS value for a sine waveform. In terms of RMS voltages, therefore, the sensitivity is 2.6 volts per inch and 8.9 volts per cm.

These figures are, of course, approximate only, for they will vary somewhat with different tubes and depend on the precise second anode voltage. It is, however, an easy matter to calibrate the tube with a battery and voltmeter.

To do this connect X₁, Y₁ and E and join Y₂ to E. Switch on, and when the tube has been given time to warm up advance the brilliance control gradually. A fuzzy spot will appear in the centre of the screen. Then adjust the focus control for the smallest and most sharply outlined spot. While doing this it may be necessary to reduce the brilliance. With a stationary spot great care should be taken to avoid excessive brilliance, otherwise the screen may be burnt.

Having obtained the focused spot, connect a battery between X₂ and E. The spot will move horizontally to left or right, depending on the polarity of the battery. Measure the amount of the displacement and also the battery voltage. Repeat, this time using the Y₂ plate; the spot will now move vertically. The sensitivity is approximately the same in this direction, but may not be exactly so.

Connected in this way the tube can be used as a voltmeter of high input impedance, and it is as accurate at audio- and low radio-frequencies as it is to steady

potentials. At the highest radio frequencies errors may occur, but not within the commonly used range.

It is worthy of note that while the application of a steady potential to the deflector plates merely results in a shifting of the position of the spot, the application of an alternating potential results in the appearance of a line. The length of this line, which is due to the spot moving rapidly to and fro, indicates the peak-to-peak value of the applied voltage.

While the ability of the tube to function as a voltmeter is useful, it would not alone justify its use, and in most cases both sets of deflector plates are employed. When alternating potentials are applied to both sets of plates, the position of the spot at any instant depends on the instantaneous values of both potentials, and with the usual repetitive waveforms a pattern appears on the screen.

One particularly useful application lies in the determination of distortion. The

amplifier under test is fed from the usual fixed frequency source, and the output is applied to one pair of plates, say between Y₂ and E. The source must be of fairly high voltage and only a fraction of it applied to the amplifier, for it must also be connected to the other pair of plates, say, between X₂ and E. Alternatively, a separate and distortionless amplifier can be used between the source and the X-plates.

If the adjustments are made so that the voltages on the X and Y plates are equal, and the amplifier is free from distortion, a straight line inclined at an angle of 45 degrees to the vertical will appear on the screen. Inequality in the voltages will be shown as a change from this angle.

Amplitude distortion results in the line being no longer straight, and phase distortion makes it turn into an ellipse. In an extreme case where the voltages are 90 degrees out of phase the trace becomes a circle.

The tube can also be used for comparing frequencies. A known frequency, such as a potential from the 50 c/s mains, is applied to one set of plates and the unknown to the other. From the resulting figure the ratio of the frequencies can be deduced, provided that the ratio is such that a stationary figure is obtained. The figures obtained are known as Lissajous' figures, and are given in most textbooks dealing with cathode-ray apparatus.

One case where this may be very useful is in the calibration of a beat-frequency

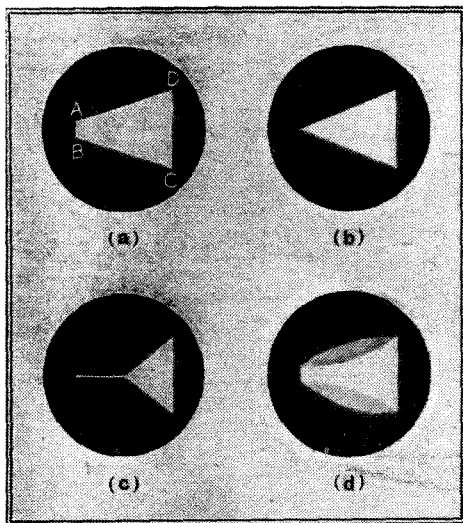

Fig. 2.—Modulation depth can be determined with the CR tube as explained in the text. Modulation less than 100 per cent. produces a picture such as (a), while 100 per cent. modulation gives (b). Over-modulation gives the effect of (c), and phase shift of (d).

List of Parts**TUBE UNIT**

- 1 Mains transformer, 370-0-370 v. 40 mA.
4 volts 2.5 amps, 4 volts 1.5 amps
C.T., 4 volts 2 amps Haynes TB64
- 1 Condenser, 8-8 mfd., electrolytic, common negative lead, case isolated, C1, C2 Dubilier 9203E
- Resistances:
2 5 megohms, ½ watt, R6, R7 Dubilier F½
1 10,000 ohms, 1 watt, R1 Dubilier F1
1 25,000 ohms, 1 watt, R4 Dubilier F1
1 100,000 ohms, 1 watt, R2 Dubilier F1
- 1 Potentiometer, 10,000 ohms, wire wound, R5 Haynes
- 1 Potentiometer, 50,000 ohms, wire wound, R3 Haynes
- 3 Connectors, plug and socket Bulglin P73
- 1 Valve holder, 5-pin W.B.
- 1 Valve holder, 9-pin W.B.
- 2 Knobs, black, ¼-in. hole, 2 grub screws
- Aluminium Chassis, comprising baseplate, 2 side pieces, front plate and engraved paxolin panel, 2 large brackets, 2 small brackets, small plate for tube holder, fitted with grommets and insulated terminals Haynes
- 6 Feet Flex, triple 5-amp
- Miscellaneous:
Screws, wire, sleeving.
- Valves:
MU14, Tube 4081 Osram

TIME BASE AND AMPLIFIER

- 1 Mains Transformer, 375-0-375 v., 4 volts 2.5 amps, 4 volts 1 amp Haynes T2714
- 1 Volume control, 1 megohm, R5 Dubilier "A"
- 1 Volume control, 0.5 megohm, R9 Dubilier "A"
- 1 Volume control, wire wound, 25,000 ohms, R13 Haynes

- 1 Volume control, wire wound, 50,000 ohms, R11 Haynes
- Condensers:
1 0.0001 mfd., mica, C10 Dubilier 691
1 0.002 mfd., mica, C15 Dubilier 690
1 0.01 mfd., mica, C14 Dubilier 690
4 0.02 mfd., mica, C4, C6, C9, C11 Dubilier 680
- 1 0.1 mfd., tubular, C13 Dubilier 4603S
- 2 0.5 mfd., tubular, C12 (two in parallel) Dubilier 4608S
- 1 Triple 1 mfd., paper block condenser, C3 Dubilier BE379
- 2 8-8 mfd., electrolytic condensers, common negative lead, case isolated, C1, C2, C7, C8 Dubilier 9203E
- 1 25 mfd. electrolytic condenser, C5. Dubilier 3016
- Resistances:
1 300 ohms, ½ watt, R17 Dubilier F½
1 350 ohms, ½ watt, R6 Dubilier F½
1 5,000 ohms, ½ watt, R14 Dubilier F½
2 10,000 ohms, ½ watt, R7, R8 Dubilier F½
- 3 25,000 ohms, ½ watt, R2, R10, R12 Dubilier F½
- 4 100,000 ohms, ½ watt, R3, R4, R15, R16 Dubilier F½
- 1 25,000 ohms, 1 watt, R1 Dubilier F1
- 2 Valve holders, 5-pin W.B.
- 2 Valve holders, 7-pin W.B.
- 1 Switch, 4-way (or 5-way) with condenser-holding plate and 2 spacers Peto-Scott
- 5 Knobs, black, ¼-in. hole, 2 grub screws
- Aluminium Chassis, comprising baseplate, 2 brackets, front plate and engraved paxolin panel with insulated terminals Haynes
- Miscellaneous: Screws, wire, sleeving.
- Valves:
1 MU14, 1 MSP4, 1 W42, 1 GT1B Osram

Cathode-ray Oscilloscope—

oscillator, for with a little care and ingenuity it is possible to carry out an accurate calibration based on the 50 c/s mains. Using the CR tube as an indicator a direct calibration against the mains is possible up to about 500 c/s. From this a separate oscillator can be fixed exactly at 500 c/s, and then used to take the calibration up to 5,000 c/s. Another fixed oscillator can then be calibrated and the main calibration extended indefinitely.

As an indicator of modulation depth in a transmitter the tube is particularly useful. The modulated RF output is applied to one pair of plates, and the AF output of the modulation amplifier to the other pair. The result is a figure which depends on the modulation depth.

With perfect modulation the figure takes the form of Fig. 2 (a) and the modulation depth is given by $\frac{CD - AB}{CD + AB} \times 100$. With 100 per cent. modulation AB is zero and the figure is a triangle (b). When the

modulation exceeds 100 per cent. the figure is a triangle with a line extending from the apex (c). A phase difference between the modulation and the modulation voltage will modify the figure to the form shown at (d).

give the horizontal deflection, and the waveform under examination is applied to the Y-plates. The pattern on the tube is then that which would be obtained by plotting as a graph the voltage variations against time with linear scales. A direct picture of the waveform is obtained.

The circuit of the time-base unit is shown in Fig. 3, and it also includes an amplifier for the waveform to be observed. The saw-tooth oscillator is operated from the tube HT supply in the tube unit, and the mains equipment in this unit is provided solely for the amplifier.

Additional smoothing of the time-base HT supply is provided by the 10,000-ohm resistances R7 and R8 in conjunction

The amplifier and time-base unit is of similar size to the tube unit.

Although the CR tube unit alone is very useful, there are many cases where a linear time-base is desirable. This is an oscillator delivering an output voltage which rises steadily with time until a certain maximum is reached, when it falls back very rapidly to its initial value and starts to rise again, and so on.

The output is applied to the X-plates to

with the 8- μ F. condensers C7 and C8. The saw-tooth oscillator is a gas-triode with a 300-ohm resistance R17 in its anode circuit to limit the anode current to a safe value. The charging condensers are C12 to C15, the required value being selected by the switch S1.

In order to obtain a linear waveform a charging valve is used, the W42; it is

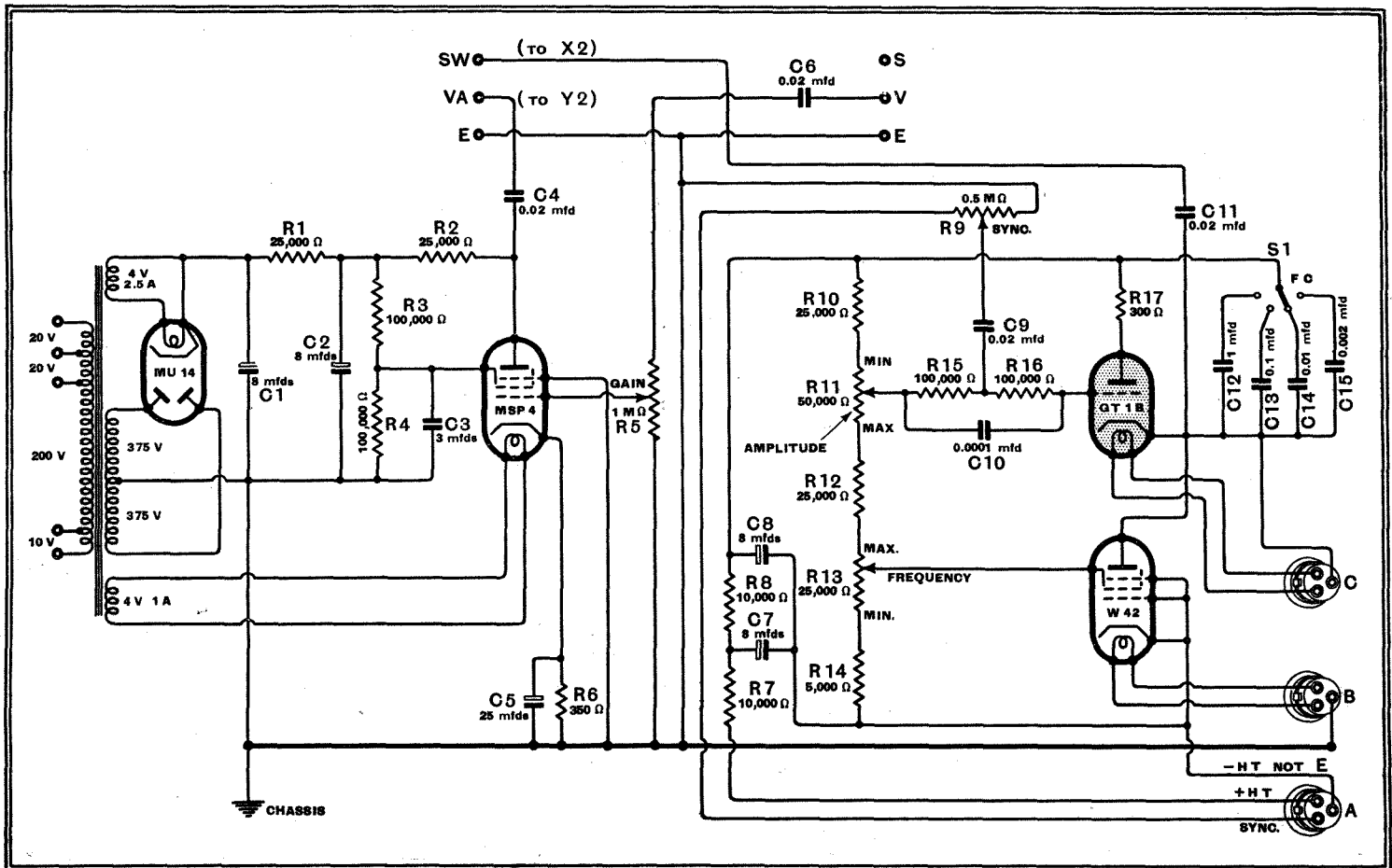

Fig. 3.—Circuit diagram of the time-base unit incorporating an amplifier for the observation of waveform.

Cathode-ray Oscilloscope—

operated with zero grid bias, and has its anode joined to the cathode of the gas-triode. The screen is fed from a voltage-divider across the HT supply, and its voltage is adjustable by R13. This is the main frequency control. The saw-tooth frequency is adjustable in steps by S1 and precisely by R13.

The grid of the gas-triode is also taken to the voltage divider, and the setting of R11 determines its grid bias, and hence the amplitude of the sweep. Synchronising is obtained by applying a portion of the voltage to be examined to the grid of this valve, and this is done with the aid of R9.

In operation the gas-triode is non-conductive, and the charging condenser, say C12, charges from the HT supply through the charging valve. The rate of charge depends on the screen potential of this valve. As it is a pentode, the anode current, which constitutes the charging current, is substantially independent of anode voltage. The voltage across C12 consequently rises at a uniform rate.

At length the voltage is sufficient to operate the gas-triode. The gas ionises and the valve becomes conductive and very rapidly discharges C12. The cycle then recommences. When the generator is synchronised a portion of the work voltage is applied to the grid. The change of

grid voltage in a positive direction, occurring just before the gas-triode would normally strike of itself, causes it to fire at a definite point of the signal cycle every time, with the result that successive traces are superimposed and a steady picture is obtained.

The amplifier is provided so that a reasonable deflection can be secured with a small input and is extremely useful in many applications. An RF pentode is used with an input gain control. It is biased by R6, shunted by the 25 μ F. electrolytic condenser C5, and the screen is fed from the voltage divider R3 R4. Resistance coupling to the tube is adopted.

As it is inconvenient to operate the amplifier from the same HT supply as the tube, because the supply for the latter has its positive earthed, separate mains equipment is provided. Resistance smoothing is again adequate, and is provided by R1 in conjunction with C1 and C2.

When using the amplifier it is important to note that it reverses the phase of the "signal" voltage. This means that if a certain waveform produces a pattern on the tube when the amplifier is not used and it is then inserted, the pattern will be upside down. In most cases this does not matter, but if it is forgotten misleading results may occasionally be obtained.

(To be concluded.)

PROBLEM CORNER-21

An extract from Henry Farrad's correspondence, published to give readers an opportunity of testing their own powers of deduction:—

90, Fays Way,
Vectorford.

Dear Henry,

We have been having a bit of an argument, and as it has reached a deadlock I am hoping you will be able to clear it up. It cropped up while discussing how to arrange for several loud speakers to be worked from one output transformer. Suppose A represents a secondary winding cor-

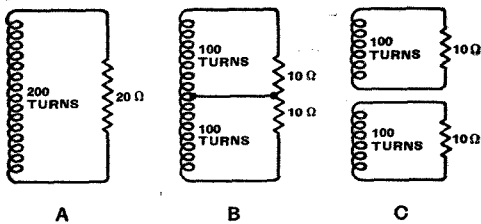

rectly designed to supply a load of 20 ohms as shown, and for the sake of argument let the number of turns be 200. Then according to the well-known rule that the ratio of turns is proportional to the square root of the ratio of impedances, it looks as if a 100-turn winding ought to be correct for supplying a quarter of the load resistance—5 ohms.

But now suppose that a centre tap on the winding is joined to a centre tap on the load, as at B, it ought (according to the Wheatstone bridge principle) to make no difference, because it joins two points that are at the same potential. But now we have 10 ohms across 100 turns. In fact, the two

halves of the winding could be separated, as shown at C, and this disagrees with the rule mentioned above.

There must be a fallacy somewhere, I suppose, but none of us can see just where it lies.

Yours sincerely,
Fred New.

How can the above result be reconciled with the "square-root-of-the-impedances" rule?—Solution on p. 501.

**The New Murphy
Portable**

Superheterodyne Circuit with an RF Stage

THE first Murphy receiver designed for quantity production was a battery portable and now after nearly 10 years the firm has introduced a new model, the B81.

First consideration has been given to performance and to judge from the specification

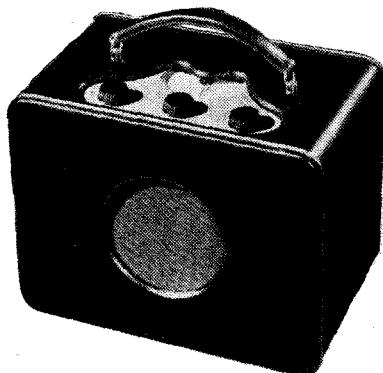

A black rexine case with green trimmings has been adopted for the B81 Murphy portable.

this should be of a high order. Adequate volume for an economical use of HT current is assured by the use of a QPP stage and a most unusual feature is the inclusion of an RF stage before the frequency-changer in the five-valve superheterodyne circuit. This should give sensitivity comparable with a four-valve table model on a medium-sized aerial and better signal-to-noise ratio than is usually available in portable receivers.

The entire chassis is mounted on rubber supports and quick-fitting rubber straps hold the batteries in place. The weight is about 25 lb. with batteries, and the price (less batteries) £8 15s.

Television Programmes

Sound 41.5 Mc/s

Vision 45 Mc/s

An hour's special film transmission intended for demonstration purposes will be given from 11 a.m. to 12 noon each weekday. The National or Regional programme will be radiated on 41.5 Mc/s from approximately 7.45 to 9 p.m. daily.

THURSDAY, MAY 25th.

3, "Lonesome Like," a short play by Harold Brighouse. 3.30, Gaumont-British News. 3.40, 245th edition of Picture Page.

9, 246th edition of Picture Page. 9.30-10.45, Boxing O.B. from Harringay Arena. The World's Welterweight Championship; Armstrong v. Roderick.

FRIDAY, MAY 26th.

3, Adelaide Hall in "Dark Sophistication," the coloured cabaret from the Old Florida Club. 3.30, British Movietonews. 3.40, "Smiling at Grief," a play by Walter Hudd.

9, Naunton Wayne in Cabaret. 9.30, Cartoon Film. 9.35, "Looking for a House," Pearl Binder describes the successful outcome of her trials. 9.45, Gaumont-British News. 9.55, Vanity Fair—modern dress design. 10.10, Film. 10.20-10.30, Music Makers—Dorothea Aspinall, pianoforte.

SATURDAY, MAY 27th.

3, C. H. Middleton, "In Our Garden." 3.15, Gaumont-British News. 3.25, Cartoon Film. 3.30, The Vic-Wells Ballet present the third act of "The Sleeping Princess."

9-10.30, "Behind the Schemes," by G. H. Grimaldi. The action takes place in the publicity office of "The Daily Quiver," Fleet Street.

SUNDAY, MAY 28th.

3, The Hotchkiss Marionettes. 3.15, Cartoon Film. 3.20, Cartoons by Harry Rutherford. 3.30, Mabel Constanduros in "Zoo and You." 3.40, Marcella Salzer in a One-Woman-Entertainment. 3.55, British Movietonews.

8.50, News. 9.5-10.35, Edmund Knight in "First Stop North," a new play by Nicholas Phipps.

MONDAY, MAY 29th.

3, Ray Ventura et ses Collegiens. 3.35, Gaumont-British News. 3.45-4.10, Polo O.B. from Hurlingham.

9, "Fantastic Garden," No. 3. 9.30-10.30, "The Fighting Texan"—Film.

TUESDAY, MAY 30th.

3-4.30, D. A. Clarke-Smith in "The Great Adventure," by Arnold Bennett.

9-10.30, "The Insect Play," by Karel Capek; adapted by Nigel Playfair and Clifford Bax.

WEDNESDAY, MAY 31st.

3-4.30, "Behind the Schemes" (as on Saturday at 9 p.m.).

9, Cabaret Cruise, with Commander A. B. Campbell. 9.45, British Movietonews. 9.55, Sunday in the Country. 10.15, Cartoon Film. 10.20, Pouishnoff, playing Grieg's pianoforte concerto in A minor with the B.B.C. Television Orchestra. 10.50, News.

Footless Valves

NEW TUNGSRAM RANGE FOR SHORT WAVES

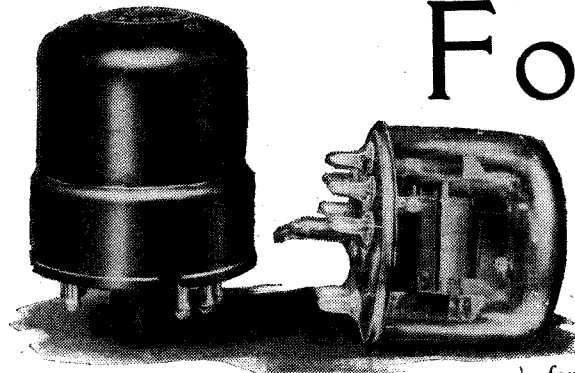

VALVE development proceeds very rapidly nowadays and the changes are more often than not in the mechanical form in order to obtain increased efficiency on short waves. One of the latest trends—the abolition of the pinch and top cap—is described in this article.

ONE of the greatest disadvantages of the conventional form of valve construction is the length of the internal connecting leads between the base pins and the electrodes. The promixity of these leads adds very considerably to the interelectrode capacities, and their length makes their inductance appreciable at high frequencies.

The inductance of the cathode lead is probably the most important, for it makes proper decoupling of the circuits impossible. One serious result is that on short waves the input resistance of the valve is considerably lower than would be the case if the electron transit time were the only factor to be taken into account. The inductance of the screen-grid lead is also disadvantageous, since it makes the effective capacities rise with frequency.

Recent valve development has lain very largely in the direction of reducing the length of the internal leads, and considerable improvement in valve performance has resulted. This process was carried to its logical conclusion some years ago in the well-known acorn, in which the very small electrode clearances also greatly reduced electron transit time effects.

While the acorn is the only suitable type of valve for some applications, it is too difficult to manufacture and too fragile for general use. Recent development, therefore, has had for its aim the attainment of electrical characteristics approaching

those of the acorn combined with a mechanical construction which is not inferior to that of ordinary valves.

This was first approached by adopting conventional forms of construction, but reducing the length of the valve and using a special form of base to reduce the length of the internal leads. One example of this development is the well-known "E" series with the side-contact base.

The next stage was to abandon the use of the glass pinch for supporting the electrodes and to substitute for it a glass ring of the same diameter as that of the circle of base pins. This ring forms part of the glass wall of the bulb, and not only gives a considerable reduction in the length of the leads, but the leads themselves are much more widely spaced in the glass support. This results in a reduction of the inter-electrode capacities and at the same time gives greater mechanical rigidity. In addition, it makes it possible to bring both anode and grid connections out to the base, instead of having to take one of them to a top-cap, because there is now room to introduce internal screening between the leads.

This in itself is by no means an unimportant development, because it permits a considerable reduction in the length of the connecting leads external to the valve. The top-cap has long been a nuisance in receiver design.

Valves of this type with an all-glass construction have been described in *The Wireless World*, and the practice has been to retain the usual vertical electrode assembly.¹ In Germany, however, Telefunken have produced a range of valves with the electrodes arranged horizontally and use an all-metal construction with glass beads for insulating the leading out wires.² The horizontal construction is claimed to give increased rigidity, because the electrodes can readily be anchored at each end.

A new range has now been introduced by Tungoram. The valves are in some ways similar to the Telefunken, for they have a horizontal electrode assembly and have the same arrangement of the base pins, but they are of all-glass construction with an external metal cover for screening and protection.

The base is a modified octal, but with a larger pin circle to increase the spacing; the pins are provided with a waist to give a locking action in the socket.

In this way mechanical rigidity and easy assembly are combined with the desirable electrical properties of the footless valve, and at the same time the advantage of the well-tried evacuation technique of a glass valve is retained.

The makers claim that in a comparison

¹ *The Wireless World*, February 16th, 23rd, 1939.

² *The Wireless World*, November 10th, 1938.

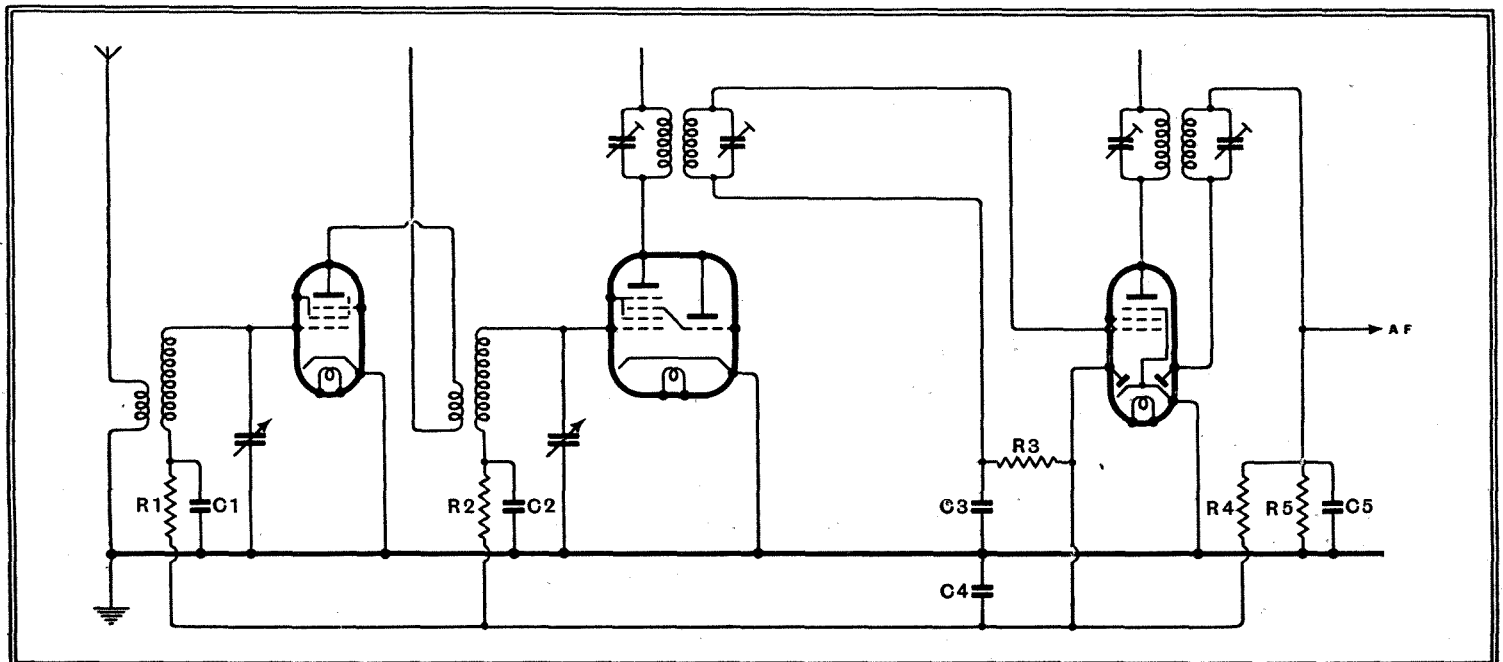

Fig. 1.—This diagram shows the simple arrangement which can be used with the valves. Initial grid bias is not essential.

Footless Valves—

of these new valves with the usual types with a pinch construction the following advantages are gained:—

Lower inter-electrode capacities and reduced internal lead length, giving improved performance on short- and ultra-short-waves.

Grid and anode connections at the same end, thus reducing external lead lengths.

Greater mechanical rigidity (every electrode has a three- or four-point suspension instead of the usual two-point).

Smaller physical dimensions.

Greater reliability because of the simpler construction.

Reduced leakage, due to the absence of the pinch and the use of fewer mica spacers, thus giving quieter operation.

The valves so far produced in this range are a variable-mu RF pentode EF11, a straight abrupt cut-off RF pentode EF12, a duo-diode-RF pentode EBF11, a triode-hexode frequency-changer ECH11, an output pentode EL11N, and a rectifier AZ11. Further valves to be produced are a cathode-ray tuning indicator EM11, and an AC/DC output pentode and rectifier CL11N and CY11.

The EF11 is rated for 250 volts and 100 volts anode and screen potentials, and at the normal bias of -2.2 volts the anode and screen currents are 6 mA. and 2 mA. respectively. When the screen potential is fixed, a bias of 17 volts is needed to reduce the mutual conductance from its normal value of 2.2 mA/v. to 0.022 mA/v. If the screen is fed from the 250-volt line through a dropping resistance of 75,000 ohms, however, 45 volts bias is needed to obtain this value of mutual conductance. The valve can thus be arranged to have either a short or a long grid base, as desired. The maximum cathode current is 10 mA. and the input and output capacities are $6.1 \mu\mu\text{F.}$ and $6.5 \mu\mu\text{F.}$ respectively with a grid-anode capacity of $0.002 \mu\mu\text{F.}$ The straight RF pentode EF12 has similar general characteristics, but the mutual conductance is 2.8 mA/v.

The Triode-hexode

The triode-hexode ECH11 is rated for 250 volts anode and 100 volts screen potentials on the hexode section with currents of 2.3 mA. and 3 mA. at 2 volts grid bias. With fixed screen potential, 13 volts bias is needed to reduce the conversion conductance from 0.65 mA/v. to 0.00325 mA/v., whereas if the screen is fed through 50,000 ohms a bias of 21 volts is necessary to bring the conversion conductance down to 0.0016 mA/v.

The triode section, which is used as the oscillator, should have a 50,000-ohm grid leak, and with the correct amplitude of oscillation the grid current is 200 $\mu\text{A.}$ The anode should be fed through 30,000 ohms from the 250-volt line and it takes a current of 3.3 mA. This section has a mutual conductance of 2.8 mA/v. with an amplification factor of 20.

The hexode section has input and output capacities of $5.3 \mu\mu\text{F.}$ and $9.1 \mu\mu\text{F.}$

respectively; the triode grid-cathode capacity is $4.3 \mu\mu\text{F.}$, the anode-cathode capacity $2.5 \mu\mu\text{F.}$ and the grid-anode capacity $1.5 \mu\mu\text{F.}$ The capacity between the hexode grid and anode is $0.001 \mu\mu\text{F.}$, between the hexode grid and the triode grid $0.2 \mu\mu\text{F.}$, and between the hexode grid and heater $0.001 \mu\mu\text{F.}$

The characteristics of the pentode section of the EBF11 duo-diode-RF pentode are very similar to those of the EF11. The anode and screen currents are 5 mA. and 1.8 mA. respectively, however, and if a dropping resistance is used for the screen supply it should have a value of 85,000 ohms.

The particular feature of this valve is the extremely low inter-electrode capacities. The input and output capacities are $4.9 \mu\mu\text{F.}$ and $6.2 \mu\mu\text{F.}$ respectively with a grid-anode capacity of less than $0.002 \mu\mu\text{F.}$ The diode capacities are D1-cathode $2.3 \mu\mu\text{F.}$, D2-cathode $2.7 \mu\mu\text{F.}$ and D1-D2 $0.5 \mu\mu\text{F.}$ The capacity between

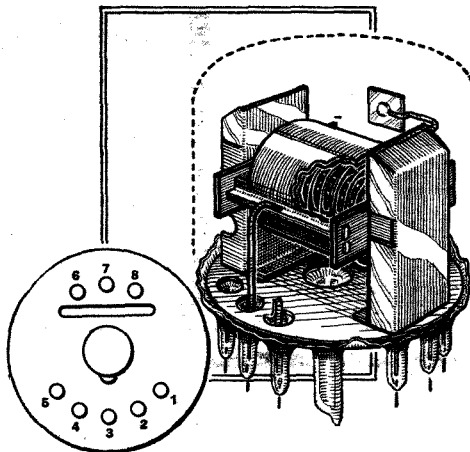

A sketch of the electrode system of an RF pentode is shown here, together with the arrangement of the base pins.

the pentode anode and either diode anode is less than $0.015 \mu\mu\text{F.}$ and between the pentode grid and either diode anode it is less than $0.001 \mu\mu\text{F.}$

These four valves all have heaters rated at 6.3 volts 0.2 ampere, but the output pentode EL11N takes 0.9 ampere at this voltage. The similar CL11N will have a heater rated at approximately 40 volts 0.2 ampere.

The EL11N is rated for 250 volts anode and 275 volts screen potentials with 6 volts grid bias, the currents being 36 mA. and 4 mA. respectively. The bias resistance should be 150 ohms and the load impedance 7,000 ohms. The output is given as 4.5 watts for 10 per cent. total harmonic distortion and the input as 4.2 volts RMS. The mutual conductance is 9 mA/v. and the AC resistance 50,000 ohms.

The AZ11 rectifier has a 4-volt 1.1-amp. filament and is of the full-wave directly-heated type. At 300 volts RMS input

the maximum output current is 100 mA., but at 500 volts input it is rated at 60 mA. only.

The base connections for these valves are given in the accompanying table, and it will be noted that the metal shell is internally connected to the cathode pin. Partly because of this, and partly to reduce the length of the external common cathode connection to the valve, the use of cathode bias is not recommended in the early stages.

Bias by means of a resistance in the negative HT lead can be used, but is usually inconvenient. The makers recommend the omission of any initial bias and that the circuit be arranged in the form shown in Fig. 1, where R1C1, R2C2, R3C3, R4C4 are the usual AVC filters. In the EBF11 one diode is used as the detector with R5 for the load resistance and C5 for the by-pass condenser. The other diode is connected after R4 to give a small measure of delay on AVC.

Owing to the fact that the diode passes current up to about -1 volt anode potential, the normal no-signal anode potential is about -0.9 volt, and the controlled valves consequently have a slightly negative grid potential which prevents their cathode currents from becoming excessive. On any normal signal, of course, bias is provided by the AVC system.

This method of operation considerably simplifies the receiver, and its only disadvantage is some reduction in the initial sensitivity. This may not always be considered a disadvantage, however, for the effect is that of a QAVC action.

The EF11, EF12, EL11N and CL11N are provisionally priced at 10s. 6d.; the ECH11 and EBF11 at 11s. 6d.; the AZ11 and CY11 at 9s., and the EM11 at 8s. 6d.

The "Princely" Portable

Model 905M, for Operation from Mains or Batteries

THE valves used in this receiver, which is available in this country through the Princely Radio and Television Corporation (of Gt. Britain) Ltd., 5 and 6, Clipstone Street, London, W.1, are of the latest 1.4-volt type, and when used as a battery set the LT is derived from dry cells. The HT battery is divided into two 45-volt units.

There are four valves in the superheterodyne circuit, with a fifth as rectifier when the set is connected for mains operation.

The Model 905M costs £10 17s. 6d., and there is a model (904B) for battery operation only at £8 18s. 6d.

The Electric Gramophone

IN the article in the May 11th issue under the above heading reference was made to the Varley BP26 Nicore HF choke. For the convenience of readers who are contemplating the construction of this equipment, Varley, Cambridge Row, Woolwich, London, S.E.18, are arranging to manufacture a special centretapped choke at a list price of 5s.

Special models of the push-pull output transformer range are also being produced, with split primary windings, at the standard price of 18s. These will be known as the types DP46SP, DP47SP and DP48SP.

BASE CONNECTIONS

Pin	1	2	3	4	5	6	7	8
EF11	—	H	H	—	A	SG	G	C, M, Sup.
EBF11	A	H	H	DA	DA	SG	G	C, M, Sup.
ECH11	A	H	H	OG	OA	SG	G	C, M
EL11N	—	H	H	—	A	SG	G	C, Sup.
AZ11	—	F	F	—	A	A	—	—

NEWS OF THE WEEK

HIGH-POWER TRANSMITTERS

Decision of the F.C.C.

SOME interesting sidelights on the refusal of the Federal Communications Commission to renew the 500-kW licence of the Crosley Radio Corporation's station WLW, as announced in *The Wireless World* of March 2nd, are revealed by our American correspondent.

Originally a 50-kW station, WLW's power has been 500 kW for nearly five years under the experimental licence granted by the F.C.C. Since the commencement of the high-power transmissions there has been almost continual controversy on the advisability of the granting of the licence—the only one in existence.

At 500 kW WLW's field at Connecticut, about 700 miles away, was said to be precisely that arrived at in the theoretical calculations which prompted the request for the increase of power. Advocates of high-power transmitters desired to have perhaps a dozen similar stations in the States to work in broad clear channels for the purpose of high-fidelity transmission in the hope of covering the entire nation.

Service Areas

This system, our correspondent says, was suggested as possibly capable of replacing the present tangle of hundreds of stations each spoiling more territory than it covers.

Perhaps the best argument of the opposition was that in a country more than 2,500 miles wide even a reasonable number of 500-kW stations could not be certain of producing dependable service areas covering all States. It is, however, difficult to say definitely what consideration finally governed the F.C.C.'s decision.

It is perhaps of interest to mention that the Federal Communications Commission of the United States Government is composed of political nominees who acquire their appointments after examination by a committee from the Congress, and are therefore not necessarily radio engineers.

Whether an aerial power of 500 kW is desirable or not, it is still fairly easy to conclude that technical considerations alone did not sway the F.C.C. in its decision to refuse the renewal of WLW's 500-kW licence. However, high-power transmitters have apparently passed from the American radio picture.

TELEVISION INTERFERENCE

British Standards for Suppression

AS the result of co-operative effort on the part of the Society of Motor Manufacturers and Traders, the B.B.C., the Electrical Research Association, and the G.P.O., the British Standards Institution has issued a specification which deals with the suppression of radio interference caused by ignition systems.

This new specification relates to the suppression of interference of various kinds, including that caused by the sundry electrical equipment of cars. It is primarily concerned with the protection of reception at points not in the immediate vicinity of the sources of interference, and the degree of suppression required has been specified with this end in view.

The causes and characteristics of the interference have been exhaustively investigated by the B.S.I. Committee, and certain methods of suppressing the interference to an adequate extent without appreciable detriment to the operation of the machinery involved have been arrived at and are described and illustrated in the specification.

The publication of this specification must not be taken as inferring that motor cars fitted by the makers with suppression devices will soon be on the market. In the event of relevant legislation coming into force, however, the guidance given in the specification should be of considerable assistance to the motor car industry, and in the meantime car owners and designers will find much to interest them in the specification B.S. No. 833-1939. This can be obtained from the British Standards Institution, 28, Victoria Street, London, S.W.1, price 2s. 2d. post free.

PROPAGATION OF RADIO WAVES

Amateurs Help in Investigations

BETWEEN the Quinquennial International Telecommunications Conferences, the last of which was held at Cairo in February, 1938, are held technical conferences which are officially known as Comité Consultatif International des Radiocommunications meetings. In preparation for the next C.C.I.R. meeting, which is to be held in Stockholm during 1940, a committee has been set up by the G.P.O. to investigate the problems emerging from the last meeting, held in Bucharest.

Great Britain is responsible for three questions at the Stockholm meeting. In the current issue of *The T. & R. Bulletin* it is pointed out that one of the questions to be discussed, that on the propagation of radio-electric waves, provides the amateur with an opportunity of making a practical contribution to the next C.C.I.R. meeting.

Data relating to horizontally polarised waves is wanted by the R.S.G.B., which has again been invited to send representatives to serve on the G.P.O. Committee. Information covering amateur observations on all frequencies above 28 Mc/s will be appreciated, and in particular practical data dealing with work on frequencies around 60, 120, and 240 Mc/s.

A Technical Sub-Committee has been set up by the R.S.G.B. to correlate the information submitted by members, and the data provided is asked to be put under eleven general headings, which are tabulated in *The T. & R. Bulletin*.

The amount of information procurable on the propagation of the ultra-high frequencies will doubtless be lessened by the recent decision of the G.P.O. not to issue further licences for transmission above 56 Mc/s.

NEW RADIO TELEPHONE

Post Office Experiments Between Great Britain and Norway

THE growth of telephone communication between the United Kingdom and Norway has taxed the submarine cable beyond its capacity. In order to avoid the rather formidable expense involved by the laying of a new cable, a series of experiments is being carried out to investigate the practicability of a beam radio-telephony service between the Orkney Islands and the west coast of Norway. Daily transmissions from a G.P.O. experimental station have been successfully received by the Bergen Radio engineers.

Our correspondent states that the Norwegian Post Office is likely to construct a similar beam telephony transmitter, and Mr. Flanagan, a G.P.O. radio engineer, recently arrived in Bergen to inspect a site at Ulrikken close to that town.

CONCERT PITCH

World Standard Fixed

AT the recent Conference called by the British Standards Institution at Broadcasting House, it was decided that the international standard of musical pitch should be fixed at 440 c/s per second for the note A in the treble clef. The Conference was attended by experts of five nations and subject to the approval of their recommendations by members of the International Standards Association, the standard will be universally adopted.

It is suggested that musicians should be able to receive the note by wireless and by telephone. It was the International Broadcasting Union which urged the I.S.A. to endeavour to bring about an international agreement.

7-Mc/s BROADCASTING

A Protest from British Amateurs

THE Radio Society of Great Britain has registered a protest with the G.P.O. regarding the unjustified and illegal opera-

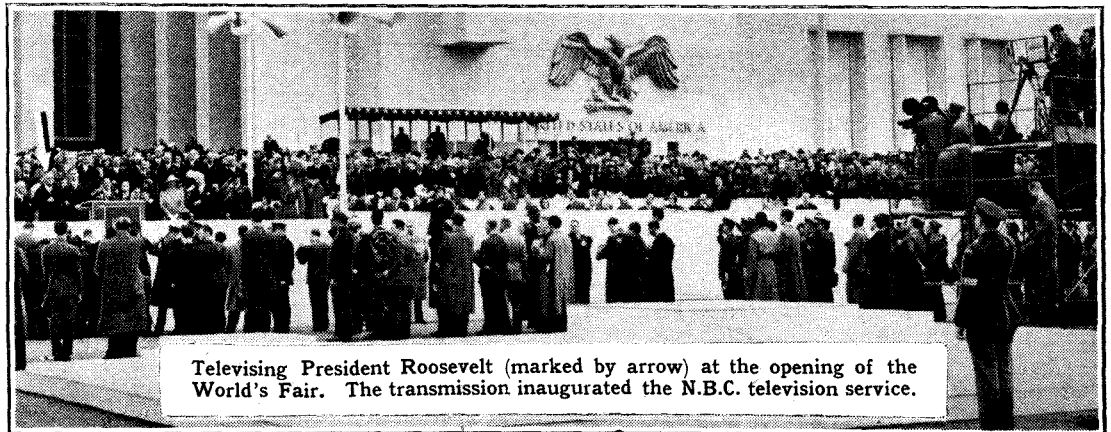

Televising President Roosevelt (marked by arrow) at the opening of the World's Fair. The transmission inaugurated the N.B.C. television service.

News of the Week—

tion of the French colonial station, Paris Mondial, on 7.28 Mc/s. The reason that prompted this protest, and that recently lodged by the A.R.R.L. with the American authorities, is that whilst the Cairo Telecommunications Conference agreed that from September 1st, 1939, broadcasting stations could transmit on frequencies between 7.2 and 7.3 Mc/s, Paris Mondial is already using 7.28 Mc/s.

The importance of the 7-Mc/s band to amateurs is stressed by the R.S.G.B., and the bi-annual occupancy figures of transmitters in this country using the band show that whereas in the second half of 1935 there were 716 amateurs transmitting on this frequency, the number in the same period last year was 1,263.

"AERADIO" TRAINING SCHOOL

AT Wallington, Surrey, about one mile from the Croydon Airport, Marconi's Wireless Telegraph Company has opened an air-radio training school, the chief instructor at which is himself a qualified operator and engineer.

In addition to the practical and theoretical training required for the Aircraft Wireless Telegraph Operator's Certificate, instruction is provided for the signalling sections of pilots' and navigators' examinations, embracing Morse lamp signalling, radio direction finding, blind-approach guidance, etc.

As there are no fixed sessions instruction is arranged to suit students' individual requirements, and subject to the existence of vacancies students may be enrolled at any time.

The school is under the local management of the manager of the Marconi Aircraft Wireless Establishment, Wandle Road, Hackbridge, Surrey, to whom applications for admission should be addressed.

40-METRE D.F. COMPETITION

SOUTHALL RADIO SOCIETY captured the first and second prizes in the 40-metre open direction finding competition which the Golders Green and Hendon Radio Scientific Society organised in the St. Albans-Harpenden area last Sunday, May 21st. The transmitter, which was operated by Mr. Corfield, G5CD (P) of the organising society, took up four different positions.

More than 60 members of the various participating wireless clubs spent a very enjoyable day. Mr. Rapsey was the winner, with Mr. Swan a close second, whilst third place was taken by Mr. Black, of the Golders Green Society.

**FROM ALL
QUARTERS****Television and the Cinema**

LAST Thursday the Postmaster-General received a deputation which included representatives of the Cinematograph Exhibitors' Association and the Kinematograph Renters' Society to discuss the effect of the development of television on the cinema industry. The deputation undertook to submit a written statement of their considered views on the subject, which the P.M.G. promised to bring to the notice of the Television Advisory Committee.

Anti-German Broadcasts

A PIRATE broadcasting station which has been transmitting anti-German propaganda in Belgium was discovered by the police last week in a house at Berchem, near Antwerp.

Pictures by Wireless

THE new system of picture transmission by wireless, now operating between Montreal and London, and New York and London, provides for the transmission of an 8½×4½ in. picture in less than eight minutes, a third of the time previously taken. As a result, finished pictures of the King and Queen's landing in Canada began to arrive at the offices of Cable and Wireless in Electra House, Moorgate, within a few minutes of the event.

Sabotage

THE Arabic and Hebrew broadcasts on the Palestine White Paper, due to have been given from Jerusalem at 8 p.m. on May 17th, were not heard. It is reported in *The Times* that a breakdown was caused by the cutting of the telephone wires between the Jerusalem studio and the Ramallah transmitter. The staff went to Ramallah and the programme was resumed at 9.30 p.m.

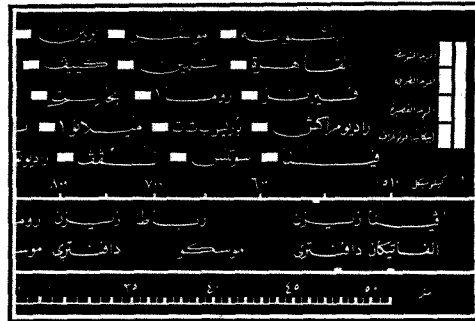

GERMAN ENTERPRISE. Perhaps the secret of the expansion of the German radio industry's overseas market lies in the care taken to provide every facility for the listener abroad. Part of the tuning dial of a Telefunken receiver in Arabic is illustrated.

B.B.C. Foreign Service

AN extended service of B.B.C. transmissions for listeners in Latin-America will start on July 3rd. The programmes, which are to take place from 11.25 p.m. to 2.20 a.m. (G.M.T.) daily, will be announced in Spanish and Portuguese. They will be radiated on GSO in the 19-metre band and GSC in the 31-metre band.

The B.B.C. in Europe

MR. H. R. CUMMINGS, former London representative of the League of Nations Secretariat, has taken up the post of B.B.C. Public Relations Officer for Europe. He was in the Wireless News Department of the Ministry of Information in the Great War, and the News Department of the Foreign Office. He joined the Secretariat in 1920.

Political Intrigue

News of political intrigue and wireless comes from the port of Piræus, Greece, where an Athenian architect erected a mortuary chapel to the memory of his deceased wife. Headed by the Bishop of Athens, a procession bearing the corpse made its way to the chapel, where subsequently the architect spent long periods of mourning shut up with the coffin. The police became suspicious, and during the mourner's absence conducted a thorough search. It was revealed that the coffin contained a complete short-wave transmitter, which was being used for nefarious political purposes. The mourner's meditations were curtailed abruptly.

I.E.E. Wireless Section

THE Committee of the I.E.E. Wireless Section has made the following nominations to fill the vacancies which will occur on the committee at the end of September: Chairman, E. B. Moullin, M.A. (Oxford University); Vice-chairman, Dr. R. L. Smith-Rose (N.P.L.); ordinary members, W. L. McPherson, B.Sc. (Eng.), (Standard Telephones and Cables), J. A. Ratcliffe, M.A. (Cambridge University), and M. G. Scroggie, B.Sc. (a consulting radio engineer and frequent contributor to *The Wireless World*).

Amateur Awards

WILSON E. BURGESS, of Westerley, U.S.A., will be presented with the William S. Paley amateur radio award for 1938. He receives this distinction for his work during the hurricane which swept large areas of New England. When power was cut off and telephone lines wrecked he kept a battery-operated transmitter working, and was for forty-six hours the only link between Westerley and the outside world.

The Hiram Percy Maxim award for 1938 goes to Owen J. Dowd, of Brooklyn, New York. The prize is awarded to the amateur under twenty-one years of age whose radio work is voted by his confrères to be the most outstanding of the year.

Car Radio Banned

A NEW regulation has been included in the Calcutta Motor Vehicle Rules by which wireless and gramophones are not to be permitted in motors in the city.

National Field Day

THE seventh annual National Field Day organised by the R.S.G.B. will be held on June 3rd and 4th. A complete list of the stations, totalling over 100, which will be operating in 28 districts, is given in the May issue of *The T. & R. Bulletin*. In each district, with the exception of one, there will be transmissions in the 1.7-, 3.5-, 7-, and 14-Mc/s band.

Extending Television

FOLLOWING the Manchester address by Mr. C. O. Stanley, Chairman of the R.M.A. Television Development Committee, in which he stressed the need for television facilities in the provinces, the Hon. Lionel Berry referred to the harmonious contact which his company, Allied Newspapers, had always had with wireless manufacturers. "We have not said 'television is coming to the North,'" he continued, "we have been careful, while advocating television, not to mislead the public by wild, rash statements."

At Imperial Airways

AMONG those affected by the extensive reorganisation of the staff of Imperial Airways is Sqdn. Ldr. E. F. Turner, former Radio Superintendent. He will now become Communications Officer, in which capacity he will be responsible for all the Company's wireless and telephone equipment, as well as the meteorological services. Sqdn. Ldr. Turner was a Signal Officer in the R.F.C. and R.A.F. from 1915 to 1935. He joined the staff of Imperial Airways in 1936.

Cost of World Convention

THE World Radio Convention, held at Sydney from April 4th to 14th, 1938, cost just over £6,300, of which sum £2,500 was granted by the N.S.W. Government. The actual cost to the organisers, the Institution of Radio Engineers (Australia), was a little over £100, the bulk being provided by contributions.

Australian I.R.E.

THE growth of the Institution of Radio Engineers (Australia), which commenced its present activities in May, 1932, is given in a recent Proceedings of the Institution. This shows that, whereas in March, 1933, the number of members was 108, the membership at the end of November last year was 441.

Enthusiasm Carried Too Far

RAIDERS drove up to a wireless dealer's shop in Spencer Street, E.C., shattered the window with a coal-hole cover, and carried away a television set. Are stolen peeps the sweetest?

Miscellaneous Advertisements and Whitsun

ALTERATIONS in our printing arrangements are necessitated with the approach of the Whitsun holidays, and miscellaneous advertisements intended for the issue of June 1st must, therefore, be received not later than first post to-morrow, Friday, May 26th.

AF Transformers Simplified

COMPARISONS WITH OTHER TYPES

By N. PARTRIDGE, B.Sc., A.M.I.E.E.

AS the author of this article points out, the belief seems to have grown up that speech-frequency transformers have little in common with power or similar types designed for constant operating conditions. A knowledge of the many points of similarity that actually exist is a great help towards a proper understanding of transformer operation.

TRANSFORMERS as employed for radio purposes fall into two well-defined groups: (a) mains or power transformers and (b) audio or speech transformers. The two types have drifted farther and farther apart until nowadays each possesses its own technical jargon and it has become traditional to treat them as distinct and separate.

This duplicity of theory is liable to puzzle the novice and to make him wonder if there is or is not a basic principle governing transformers as a whole. How is it that in the one case voltage ratios are so important, while in the other the square root of the impedance ratio takes priority? Why is the no-load current never mentioned in connection with audio transformers and primary inductance totally ignored in the power type? What is the difficulty about bass response when a power transformer can be designed to work on 25 c/s without the slightest trouble?

The relationship between the mains and audio branches of the transformer family is a little analogous to that existing between the imaginary Smiths of Eastown and the hypothetical Smythes of Westown. In reality both are very human individuals, guided by the same emotions and striving towards the same end. The apparent difference is to be found in the technique of living and is entirely superficial as far as the zoologist, anthropologist, or whatever - ologist studies these things, is concerned.

For example, our Smythes might indulge in an apéritif before dinner, whereas our Smiths would undoubtedly prefer half a pint at the local hostelry prior to their equivalent of the aforesaid meal. Note how unlike are the technical terms! Nevertheless, a few simple experiments with apéritifs and half-pints will reveal certain points of similarity to the scientific

enquirer. Likewise the procedures of "indulging in" the former and "having one" of the latter possess much in common.

Mains and audio transformers are fundamentally the same, but the widely different applications have made it convenient to approach design problems in technically different ways. Allowing a brief interval subsequent to the "half-pint" experiments, we will proceed to show how the two modes of thought may be correlated.

Electricity for power and lighting is distributed by means of a constant voltage system. This does not necessarily imply that one's supply voltage is, in fact, rigidly constant, but simply that all the houses in one district have the same mythical number stamped upon their meters. Should this be, say, 230 V, then we make a special point of buying lamps, cookers, etc., that

the kilowatt-hour, and therefore the cost per hour or per day will be proportional to the watts. It follows that the current practice of rating things in volts and watts, such as a 230-V, 60-watt lamp or a 210-V, 3-kW fire, is very convenient and is sufficiently simple to be of use to the non-technical public.

All apparatus taking constant watts at a stated voltage must draw a fixed current which can be calculated by dividing the watts by the voltage. Thus the 230-V, 60-watt lamp will pass 0.26 amp. and it might well be called a 230-V, 0.26-amp. lamp, which is electrically just as specific. Again, the lamp has got a resistance or impedance which is found by dividing the voltage by the current and is, in this case,

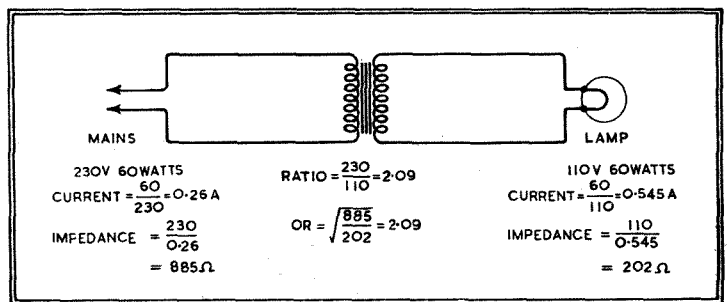

Fig. 1.—Illustrating the functioning of a power transformer working under constant operating conditions.

885 ohms. Hence we might call it a 230-V, 885-ohm lamp, or perhaps a 0.26 amp., 885-ohm lamp or, indeed, a 60-watt 885-ohm lamp. Any one of these specifications is complete in itself and all of the others can be derived from it. Table 1 sets out the watts, volts, current and impedances of several typical pieces of domestic apparatus.

In order to get back to transformers, we will assume that Mr. Brown has had a 110-V, 60-watt lamp bequeathed to him and that he wishes to use it in his home, which is connected to the 230-V, 50-cycle system. Any ordinary individual can see that a transformer with a 230-V primary and an output of 110 V, 60 watts will do the job admirably. The ratio of the transformer would be $230 \div 110 = 2.09$ to 1 step-down, and from a knowledge of small transformers the no-load current would be about 0.06 amp.

Designing by "AF" Rules

But suppose Mr. Brown is not an ordinary individual. Imagine him to be an ardent designer of audio-frequency gear, whose life is one long round of decibels and impedances. Referring to Table 1, it will be seen that an impedance of 202 ohms, i.e., that of a 110-V, 60-watt lamp, has got to be matched to, or made to behave like, 885 ohms, i.e., impedance of a 230-V, 60-watt lamp (see Fig. 1). Therefore Mr.

TABLE 1

Appliance	Watts	Volts	Amps	Ohms
Lamp... ..	60	100	0.600	167.0
		110	0.545	202.0
		200	0.300	666.0
		230	0.260	885.0
		250	0.240	1,040.0
Lamp... ..	100	100	1.000	100.0
		110	0.910	121.0
		200	0.500	400.0
		230	0.435	528.0
		250	0.400	625.0
Bowl Fire ...	500	100	5.00	20.0
		110	4.54	24.2
		200	2.50	80.0
		230	2.17	106.0
		250	2.00	125.0
Radiator ...	2,000	100	20.0	5.0
		110	18.2	6.05
		200	10.0	20.0
		230	8.7	26.4
		250	8.0	31.3

are constructed to operate on 230 V. Hence one of the first things a purchaser wishes to know is that the nominal voltage of the equipment in view agrees with that of his supply. The next thing is, how much will it cost to run? Power is sold by

AF Transformers Simplified—

Brown might absentmindedly say that the transformer ratio should be

$$\sqrt{\frac{885}{202}} = \sqrt{4.38} = 2.09$$

and, extraordinary as it may seem, he will get the correct answer. Actually there is nothing extraordinary about it, because the voltage ratio and the root of the impedance ratio are one and the same thing. The two calculations are just two different ways of arriving at the same answer.

Having determined the transformer ratio, Mr. Brown will probably ponder upon the frequency of the supply. Being as low as 50 c/s, the transformer must have a good bass response. The upper register is unimportant, so he can afford to make the primary impedance, say, four times that of the load (885 ohms), and the required primary inductance comes out at around 12 H, which is the same as that of a 230-V mains transformer drawing 0.06 amp. no-load current.

Our newly acquired friend gets accurate results even if he does go a long way round the houses to get them. But why should he choose so cumbersome a scheme when our own volts-watts mode of working is so delightfully simple? The answer is that an optimum load or a loud speaker cannot usefully be rated in volts and watts.

Consider a 15-ohm speaker engaged upon the task of emitting a typical radio programme. Between items there is silence and, therefore, no audio-frequency volts across the speech coil and no audio-frequency current through the winding. A little later massed trombones and tympani may be rendering Wagner, and there will be an abundance of volts and amps. around the speech coil. Clearly the speech volts, current and watts delivered to the speaker will vary from instant to instant throughout the entire transmission. There is only one thing that can, with justification, be regarded as constant and that is the nominal impedance of the speech coil, namely, 15 ohms.

The above reasoning applies equally to

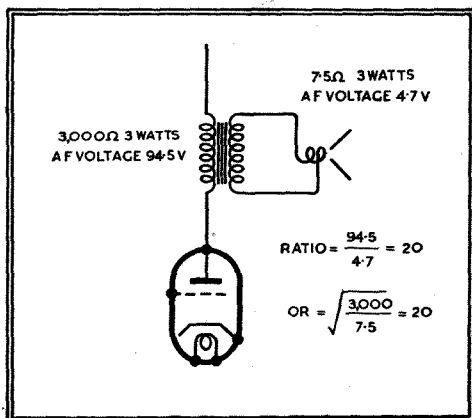

Fig. 2.—This diagram, representing a speech-frequency transformer in an output stage, should be compared with Fig. 1.

pick-ups, sound-heads, microphones, speech lines, valve anode circuits, etc. One is compelled to talk in terms of impedances instead of volts and watts. Thus we say that a certain valve has an op-

timum load of 6,000 ohms. Sometimes the maximum output, perhaps 5 watts, may be added. But the latter is strictly a statement of maximum power and does not compare with the watts specification of a lamp which relates to the power taken continuously.

Table 2 is the equivalent of Table 1, but deals with optimum loads and speakers instead of household appliances. The first group of volts and amps shows the voltages and currents that would result if a steady 3 watts were being dissipated. The

Once again the same answer is obtained, whichever of the two methods of working are used. It should be noted, however, that in order to use the simple volts ratio we had to devise Table 2, which involved a lot of juggling with Ohm's Law and several arithmetical processes. Mr. Brown's idea of taking the root of the impedance ratio avoids this inconvenience and gives the answer in one step.

A good transformer, mains or audio, should have a high efficiency, and the watts put into the primary should be substan-

TABLE 2

Impedance Ohms	3 Watts		6 Watts		9 Watts		12 Watts	
	Volts	Amps.	Volts	Amps.	Volts	Amps.	Volts	Amps.
10,000	173.0	0.0173	246.0	0.0244	300.0	0.0300	347.0	0.0346
8,000	155.0	0.0193	219.0	0.0274	268.0	0.0336	310.0	0.0386
6,000	134.0	0.0224	190.0	0.0316	232.0	0.0388	268.0	0.0448
4,000	109.0	0.0275	155.0	0.0386	189.0	0.0476	219.0	0.0550
3,000	94.5	0.0317	134.0	0.0447	164.0	0.0549	189.0	0.0634
2,000	77.5	0.0387	109.5	0.0548	134.0	0.0670	155.0	0.0774
1,000	55.0	0.0545	78.0	0.0770	95.0	0.0948	110.0	0.1090
30	9.4	0.32	13.4	0.45	16.4	0.55	18.9	0.64
15	6.7	0.45	9.5	0.63	11.6	0.77	13.4	0.90
10	5.5	0.55	7.8	0.77	9.5	0.95	11.0	1.10
7.5	4.7	0.64	6.7	0.90	8.2	1.10	9.4	1.28
4	3.5	0.86	4.4	1.36	6.0	1.50	7.0	1.72
2	2.45	1.22	3.46	1.73	4.25	2.12	4.9	2.44

remaining columns give similar information for powers of 6, 9 and 12 watts.

An example or two will make clear what this table is about. Suppose a push-pull pair of valves has an anode-to-anode load of 10,000 ohms. If a steady voltage is fed to the grids of these valves and the volume adjusted so that an output of 3 watts is obtained, then the audio-frequency voltage across the 10,000-ohm load will be 173 V and the audio-frequency current will be 0.0173 amp. Similarly, if the volume is increased until the output reaches 9 watts the figures will become 300 V and 0.030 amp. Corresponding values for 6 watts and 12 watts are shown in the table to be 246 V, 0.244 amp. and 347 V, 0.0346 amp. respectively. The lower impedances mentioned in the table correspond to those frequently employed for speakers. Thus a 15-ohm speaker fed with a steady 6 watts will draw 0.63 amp. at 9.5 V and a 2-ohm speaker 1.73 amp. at 3.46 V.

Having held up the programme in order temporarily to fix the volts, current and watts we may as well see if our elementary ideas of voltage matching hold good. Suppose we try to match a $7\frac{1}{2}$ -ohm speaker to a valve requiring a load of 3,000 ohms. At 3 watts the corresponding voltages are 4.7 V and 94.5 V, hence a transformer with a primary wound for 94.5 V and a secondary output of 4.7 V should be correct, *i.e.*, the ratio would be $94.5 \div 4.7 = 20:1$ (see Fig. 2). At a volume corresponding to 6 watts the values are 6.7 V and 134 V, which again give a ratio of 20:1. And still the same ratio is arrived at by taking the figures given for 9 or 12 watts.

The more orthodox calculation for determining the output transformer ratio would be:—

$$\sqrt{\frac{3000}{7.5}} = \sqrt{400} = 20$$

tially equal to the watts given out from the secondary. Hence all a transformer does is to increase or reduce the voltage and current in such a way that the product of the two, *i.e.*, the watts, remains unaltered. The apparent impedance of the primary and the impedance across the secondary can be calculated from Ohm's Law (volts divided by the amps.) and the root of the ratio of these impedances always comes out to be the same as the voltage ratio, which in turn is the same as the reciprocal of the current ratio. When converting one voltage to another the transformer ratio is most easily calculated direct from the voltage ratio, when working in currents it is best determined from the reciprocal of the current ratio, and when dealing with audio circuits, where neither voltage nor current is constant, the quickest method in the long run is to employ the root of the impedance ratio.

Conclusions

The foregoing revelation does not entirely reduce the audio-frequency transformer to the level of the power transformer. Neither does it suggest that they are equally simple to manufacture. The power transformer works on a fixed frequency and at a constant flux density, *i.e.*, constant voltage. It is not difficult to design a transformer to operate at 10 cycles or at 20,000 cycles, but it is rather a task to make it work well at both of these frequencies. Again, flux density has a strong bearing upon iron loss and iron distortion. The output transformer must be satisfactory in this respect at any density from the maximum downwards and at any frequency. The power transformer can be regarded as a special case of the output transformer in which the frequency and primary voltage are fixed.

The Wireless World DC Mains Super

CONSTRUCTION AND ADJUSTMENT

THERE is nothing difficult in the construction and wiring of the receiver, for all parts are reasonably accessible, and the details are shown in the drawings which accompany this article. Care should be taken to see that the switches are mounted correctly in the tuner. This is chiefly a matter of ensuring that the centre rotating discs carrying the contact studs are all in the same relative positions before inserting the operating shaft. This point should be watched, since it is possible for the shaft to be inserted with the switch discs turned 180 degrees from their correct positions. Naturally, the contact studs do not then fall on the contact arms.

Check this carefully while assembling the components, for it is then easy to put it right if a mistake has been made. If it is only discovered when the coils and wiring are in place a lot of dismantling will be needed.

The coils are identifiable by their

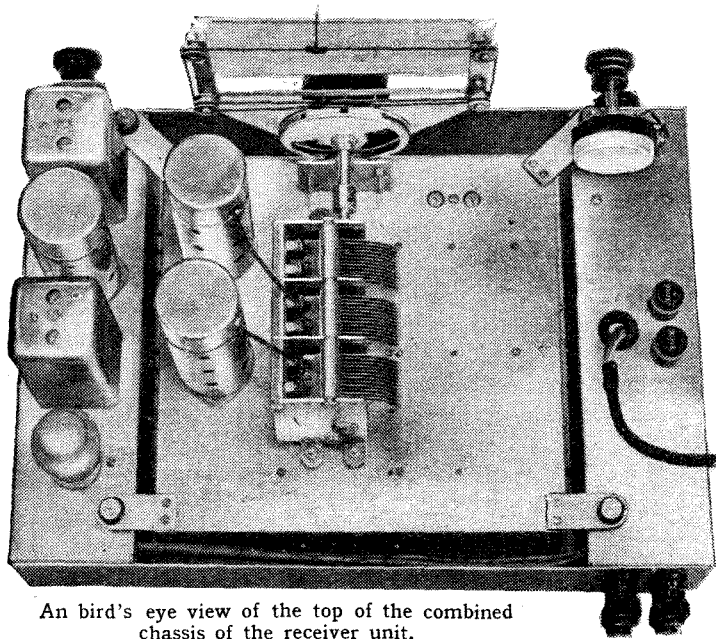

An bird's eye view of the top of the combined chassis of the receiver unit.

appearance, but the long, medium and short-wave coils also bear the numbers 1, 2, and 3 respectively, stamped on the brass mounting strips. The aerial coils are unmarked otherwise, the RF transformers carry a red spot on the former,

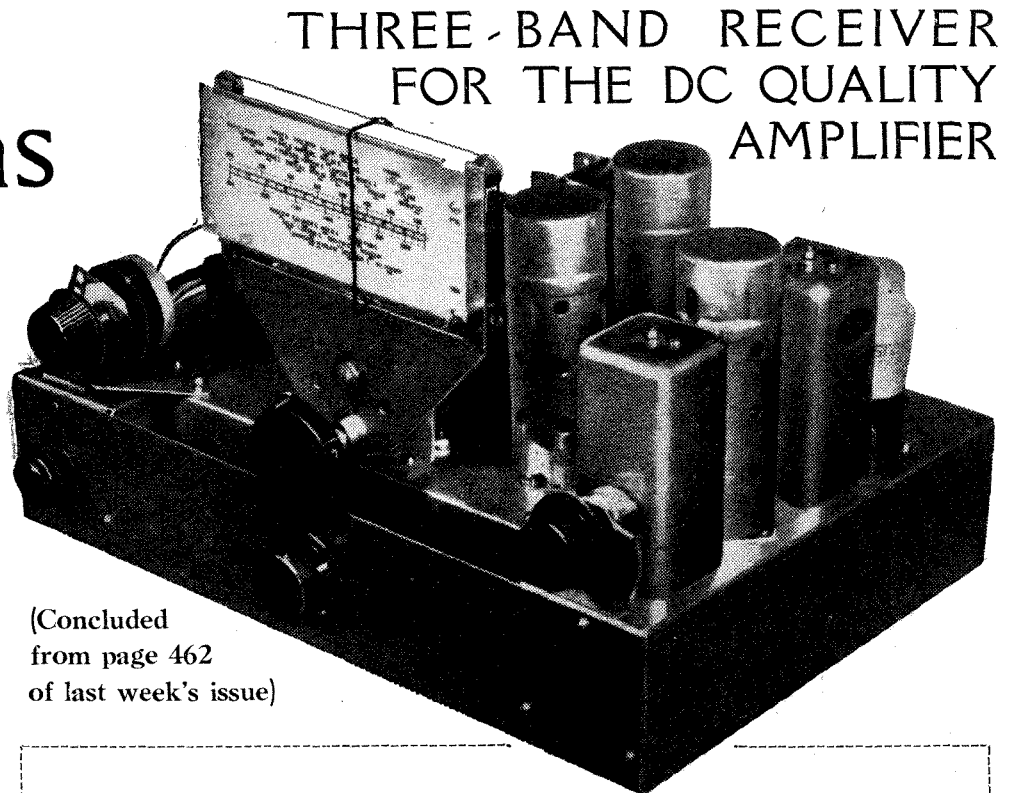

(Concluded from page 462 of last week's issue)

In this article details are given of the construction and adjustment of this DC mains set. A description of its performance is also given when tested in conjunction with the DC Quality Amplifier.

and the oscillator coils a blue spot. In every case the long pair of solder tags is for the tuned winding. For the medium and short-wave coils, the grid end of the coil is remote from the primary winding and can readily be traced to its tag; the identification of the other tags then follows from the drawings.

On the long waveband it does not matter which of the long tags is used for the grid connection.

It must be remembered when using the apparatus that the chassis and all metal parts are live to the mains. Adequate insulation must thus be provided both from earth and from accidental contact. When the apparatus is installed in a cabinet, do not forget to see that the grub screws in the control knobs are adequately sunk so that they cannot be touched.

In order to avoid hum pick-up a screened lead should be used for the AF connection between the receiver and the amplifier, and "chassis" terminals are provided on each unit for connection to the screening. The connection should not, of course, be longer than necessary, but a yard length has been used.

The initial adjustments needed are only the usual and are best made with a modulated test oscillator. This oscillator should be set to 465 kc/s and its output clipped to the grid of the IF valve. The two trimmers in T2 are then to be adjusted for maximum output. The oscillator output is then transferred to the grid of the frequency-changer and the two trimmers in T1 similarly adjusted for maximum response—of course, with the switch S7 set for high selectivity. Then check over all four IF trimmers carefully.

Ganging

Next connect the test oscillator to the aerial and earth terminals and set the waveband switch for the medium waves. If the oscillator is capable of a fairly large output, as most are, set it to 1,500 kc/s (200 metres) and the gang condenser to its minimum capacity. Short-circuit the medium-wave oscillator coil by a short lead terminating in crocodile clips and connect a low range voltmeter across R2. With the test oscillator at full output, tune to it by the trimmers C7 and C17. As the circuits come into resonance the meter reading will fall slightly if the oscillator output is adequate.

Then set the oscillator to 1,400 kc/s and tune the receiver to it by the gang condenser and readjust C7 and C17 at this frequency. Then remove the short-circuit from the set oscillator and reduce the output of the test oscillator considerably. Follow this by adjusting C27. Its setting will be very critical.

The next steps are to reapply the short-

The Wireless World DC MAINS SUPER : Wiring Diagram

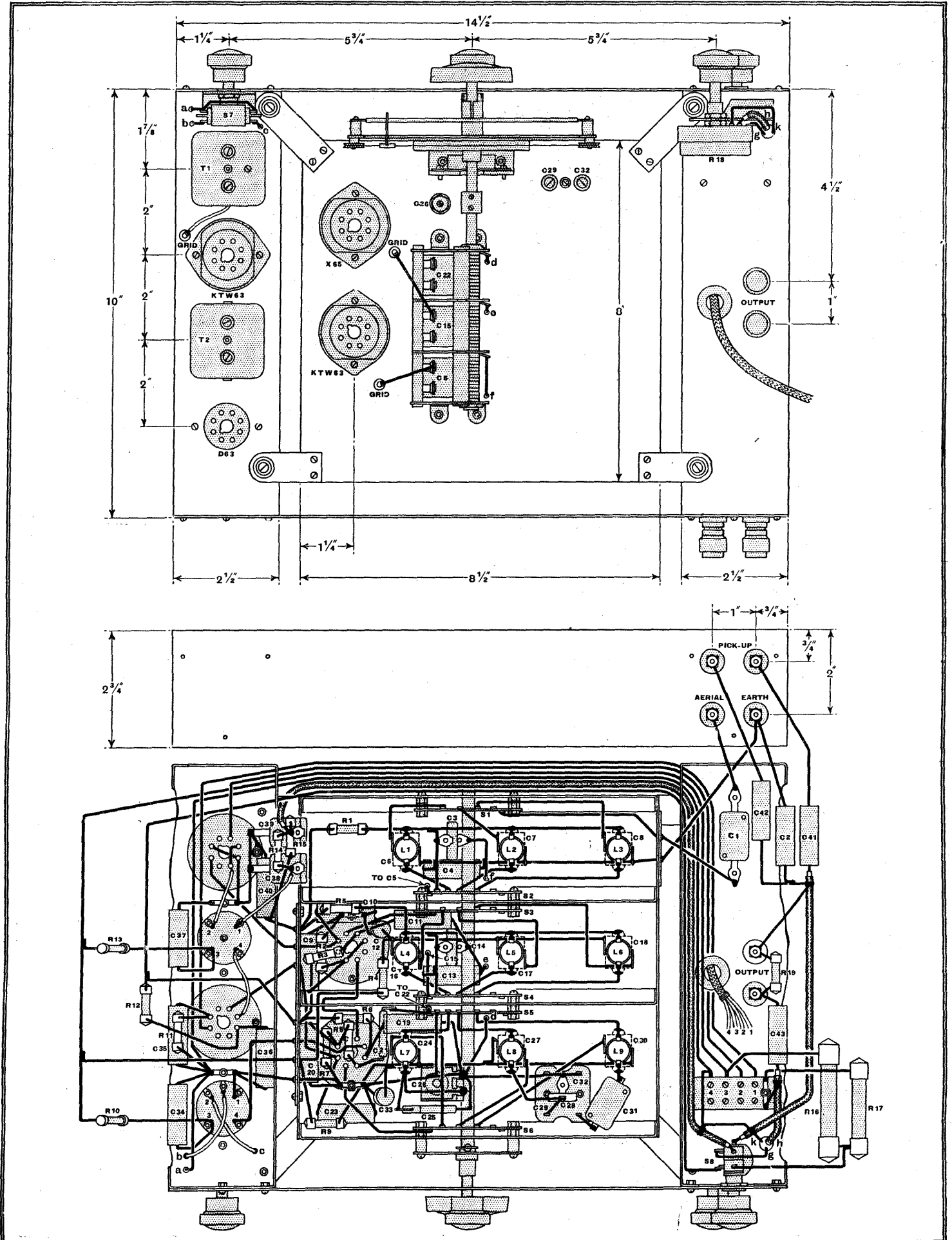

The identification of the components is readily carried out with the aid of the reference letters and the circuit diagram printed last week.

DC Mains Super—

circuit to the set oscillator, to set the test oscillator to full output at 600 kc/s and to tune the set to it by the gang condenser, again using the voltmeter as an indicator. Then remove the short-circuit, reduce the output of the test oscillator, and adjust the padding condenser C29. A return to 1,400 kc/s should then be made for a probable slight readjustment to C27.

On the long waveband the procedure is exactly the same, but the trimmers are C8 and C18 for the signal-frequency circuits and C30 and C32 for the oscillator. The first three are adjusted in exactly the

tuning control so that its frequency coincides with the receiver tuning. There will be two settings and one will give a stronger signal than the other. They will be found round about 12-15 Mc/s (20-25 metres).

Choose the stronger setting, and then adjust C6 and C16 for maximum signal strength. Next bring the test oscillator over to the other weaker setting and note whether it corresponds to a lower or a higher frequency than the stronger. If the weaker setting is at a higher frequency (lower wavelength) of the test oscillator than the strong one, all is well.

high standard of reproduction. The quality, in fact, was up to the best AC standards and far superior to most DC equipment.

On the mains employed in the tests hum was inaudible. There is no reason why hum should be expected in any district, but DC mains undoubtedly do vary greatly and it is impossible to be certain that hum will be absent in every case. Individual treatment is sometimes necessary with a DC supply.

The receiver covers the usual medium and long waves and is capable of receiving most worth-while transmissions on

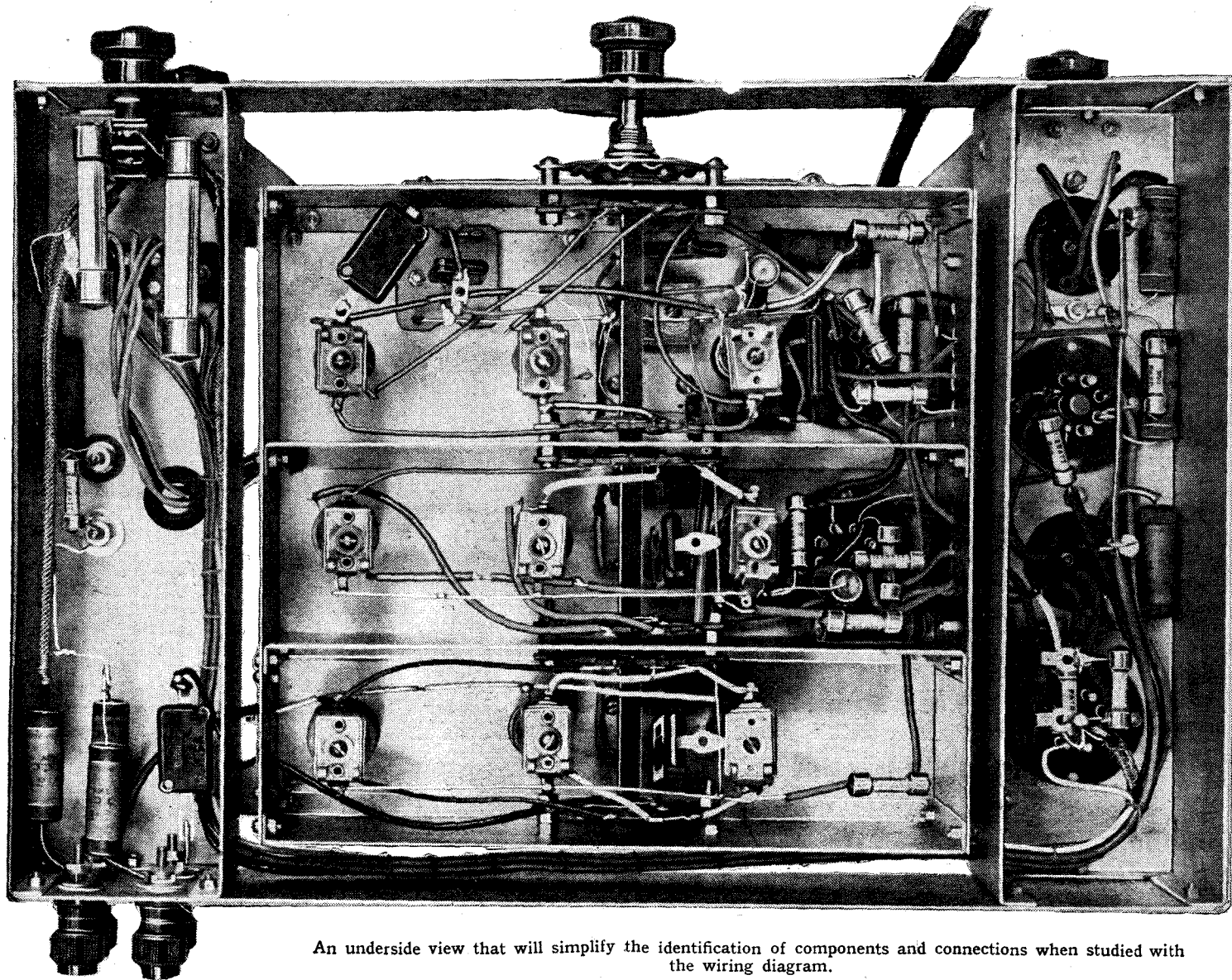

An underside view that will simplify the identification of components and connections when studied with the wiring diagram.

same way as the medium wave ones, but at 260 kc/s instead of 1,400 kc/s. Then C32 is adjusted at 170 kc/s.

This procedure is theoretically possible also on short waves, but in practice rarely works very well. Set the gang condenser with the vanes about one-quarter enmeshed, and screw up C6 and C16 about half way. Then adjust C24. Even if no signal is found, there will usually be a point at which some hiss or local interference becomes audible. This affords an opportunity to adjust the signal circuits roughly.

Then connect the test oscillator to the aerial and earth terminals and swing its

If it is at a lower frequency, however, the receiver has been lined up on the wrong beat. Increase the capacity in C6 and C16 and reduce that in C24, while retuning by the main control to keep the signal. Then carry out the adjustments in the manner already described.

The padding condenser C26 should be adjusted at the other end of the band, while rocking the tuning control backwards and forwards. It is not usually very critical, however, and is generally nearly fully screwed up.

On test the receiver was found to give a very good account of itself, being sensitive and selective, while capable of a very

these bands. When interference conditions permit, advantage can be taken of the variable selectivity to improve the quality to a really high standard, but for general distant listening the use of high selectivity is advised.

The aerial is not unimportant and an outdoor aerial of reasonable efficiency is to be recommended, not necessarily because the receiver will not give a good signal with a poor aerial, but because the signal-noise ratio is always better with a good one.

On short waves the band of about 16-45 metres is covered so that the more important stations are included. Tuning here

DC Mains Super—

is quite critical and the control should be rotated quite slowly or all but the strong signals will be passed over unnoticed. At suitable times, signals on the 16-metre, 19-, 25-, and 31-metre broadcast bands can usually be found, as well as the 20- and 40-metre amateur bands. In between these bands there are hosts of commer-

cial transmissions employing CW or ICW morse, or "scrambled" speech.

In conclusion, it should be pointed out that two errors occurred in the circuit diagram in last week's issue. The padding condensers C31 and C32 were shown in parallel instead of in series, and the two leads to the centre and top contacts on the left-hand side of S8 should be reversed.

is connected across the volume control to increase the cut top. Finally, in the fourth position ("Foreign") the top cut is left as it is and the bass boost removed by once again applying negative feedback at all frequencies.

Negative feedback is taken from the secondary of the output transformer and introduced into the grid circuit of the triode first AF amplifier via a tapping on the volume control. The effect is to increase the ratio of bass response at low volume levels and so to compensate for the subjective raising of pitch.

As in most receivers with motor tuning it is necessary to verify the setting of the waverange switch before (or after) pressing one of the station buttons, but in all other respects the mechanism has been rendered foolproof by a comprehensive switching system. Automatic frequency control is made inoperative when the manual tuning button is pressed and also while the motor

Test Report**McMICHAEL MODEL 382**

Table Model AC Superheterodyne (8 Valves + Rectifier) and
Tuning Indicator
Price 18½ guineas

IN designing this receiver the makers have first of all established a radio performance adequate for present receiving conditions and have then concentrated on refinements in the controls and automatic tuning arrangements which will improve the ease of handling without affecting performance. In particular, quality of reproduction has been carefully nursed throughout the circuit, and the performance in this respect is outstandingly good. An efficient motor tuning mechanism gives push-button selection of eleven stations.

Circuit.—The valves in the direct line of amplification from aerial to loud speaker comprise a triode hexode frequency-changer with band-pass input on medium and long waves, pentode IF amplifier, diode-triode signal rectifier and first AF amplifier and a beam tetrode output valve.

The control voltage for the tuning indicator is taken from the diode load resistance and an untuned third winding on the output IF transformer goes to the auxiliary IF amplifier supplying the AVC and automatic tuning (AFC) circuits. The use of this extra valve as a separate IF amplifier instead of as an RF stage before the frequency-changer has the advantage that signals below the AVC delay level which may be of

good programme value are still capable of operating the AFC circuits. Of equal importance is the complete isolation of the AVC diode from the signal circuits and the consequent elimination of AVC distortion.

The AFC discriminator is the conventional balanced diode arrangement and the control bias is applied to a separate screened pentode valve which alters the reactance of the oscillator section of the frequency-changer valve in the appropriate direction to correct the tuning of the incoming signal.

A very effective tone control system incorporating both selectivity in the IF stage and negative feedback in the AF circuits has been adopted. There are four positions. In the first ("Fidelity") the band-width in the IF amplifier is increased by tighter coupling in the input transformer, and negative feedback incorporating tone correction which increases low-note response is introduced in the AF circuits. For the remaining positions the selectivity is returned to maximum and the second ("Normal") setting gives negative feedback at all audio frequencies, *i.e.*, less bass as well as a reduction of top from the increased selectivity. In the third ("Bass") position, one correction is re-introduced in the feedback restoring the relative lift in the bass and a by-pass condenser

WAVERANGES

Short	- -	18.6—50 metres
Medium	- -	200—550 metres
Long	- -	850—2,000 metres

is running during automatic tuning. In this way, "trailing" of a powerful local station which might take charge up to the point where the motor came to rest is avoided. If two buttons are pressed simultaneously the contacts are so arranged that only one takes effect and the motor cannot "lock."

Performance.—Among the many attractive features of this set we would put first the quality of reproduction. A cabinet on the large side for a table model, a 10-inch loud speaker and a powerful output stage all contribute to the impression of console rather than table model quality. In the "Fidelity" position of the tone control switch the set does not require any special type of programme to show off its paces, a

sure sign that the frequency range is wide and free from resonances. Both bass and treble show a considerable extension beyond the limits usually set in commercial receivers, and it is interesting to see that the makers regard the now almost forsaken band-pass input circuit as a worth-while refinement. The volume is unusually full, and there is little doubt that the output tetrode is giving the 5 watts at which it is rated with the minimum generation of harmonics. The tone compensated volume control works well, and maintains a good foundation of bass at low levels, and the four-position tone control with its multiple functions in various parts of the circuit is a great improvement over the simpler types.

The set makes no pretence to a "hot stuff" performance, but, never-

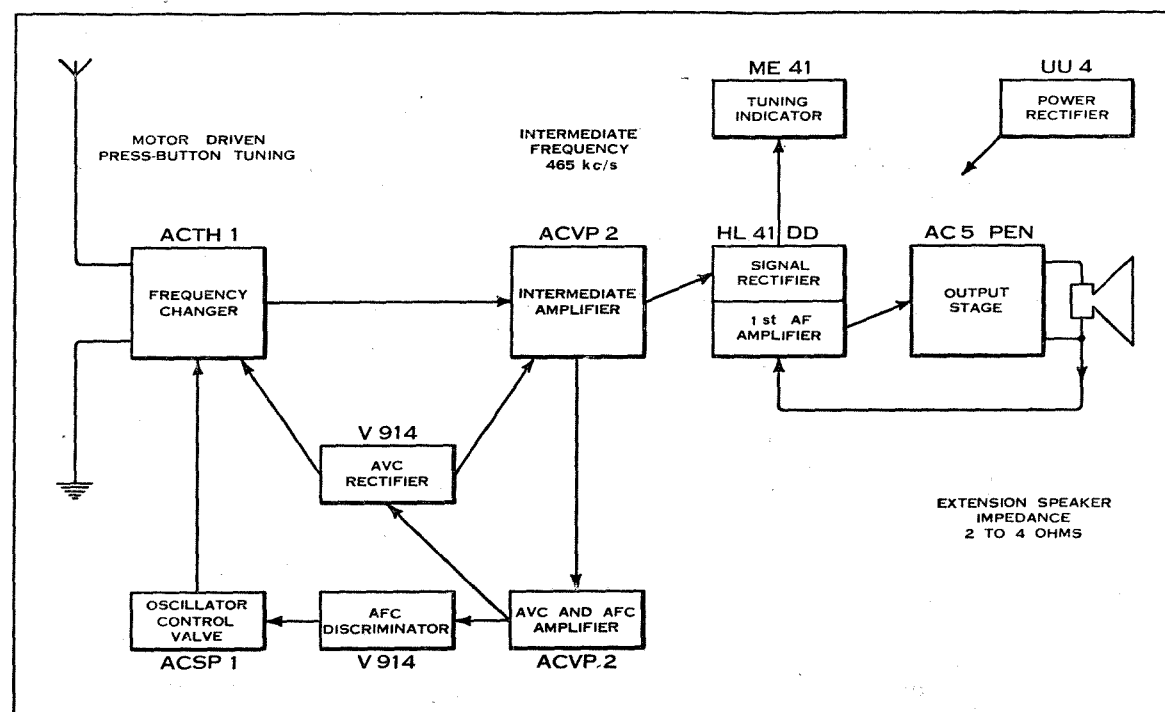

Schematic circuit diagram of the McMichael Model 382.

McMichael Model 382—

theless, brings in everything worth listening to with unobtrusive efficiency and the minimum of background noise. This is especially true of the medium and long waves which are clear of self-generated whistles, and sufficiently selective to satisfy all normal requirements. London Regional at a distance of 15 miles spreads the usual $1\frac{1}{2}$ channels each side of its normal tuning point, and

of the scale to another, and the small centre knob final manual adjustment with a high reduction ratio. If the "scanning" control is operated while the set is under automatic control, a loud hum from the receiver warns the user "not to touch."

Summary.—This receiver gives a refreshing change from the stereotyped performance of the small table model superheterodyne. The extra cost is more than

cycle field day. There have also recently been talks on USW and DF apparatus. Several field days are to be held during the summer.

Maidstone Radio Society

Headquarters: 244, Upper Fant Road, Maidstone, Kent.
Meetings: Tuesdays at 7.45 p.m.

Hon. Sec.: Mr. P. M. S. Hedgeland, 8, Hayle Road, Maidstone, Kent.

A party of members spent an enjoyable evening at the Medway Society's "hamfest" on May 10th.

On June 3rd and 4th Mr. S. A. G. Cook will be operating his portable transmitter as an unofficial NFD station. A DF field day will be held on June 18th.

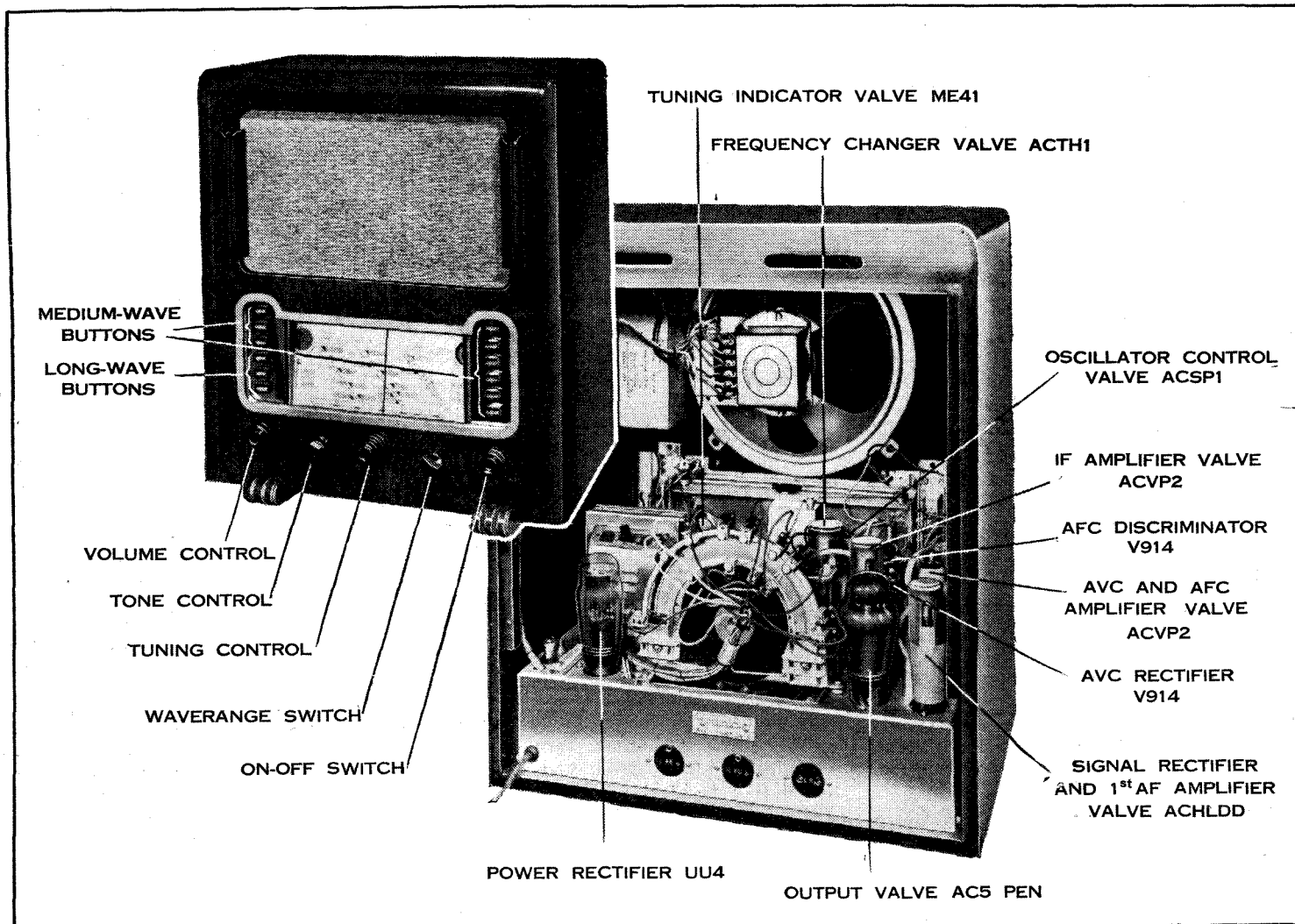

Layout of valves and controls in the McMichael 382. As sent out from the works three buttons are set for long and eight for medium-wave stations. The bottom right-hand button changes the circuits for manual operation.

on long waves the Deutschlandsender programme can be well received with the tone control in the "Normal" position.

The good entertainment value of the receiver owes much to its efficient amplified AVC system, the advantages of which are nowhere more apparent than on the short-waves. Instead of flitting from station to station we found much more incentive to settle down to the enjoyment of full length programmes.

Constructional Details.—The chassis is a straightforward engineering job without gadgets, and is finished to the standard which McMichael have always set themselves. The cabinet design is simple and dignified with a large rectangular tuning scale bordered by two vertical rows of push buttons. Indicators show the settings of the waverange and volume controls, and a pilot light coloured to match the tuning indicator shows when the controls are set for automatic tuning. The tuning indicator is illuminated only when the "Manual" button is pressed.

A concentric two-speed tuning control is fitted, the outer ring of which gives motor "cruising" or "scanning" from one part

justified by (1) the exceptionally good quality of reproduction, (2) the general smoothness and ease of handling imparted by a good motor tuning device backed by efficient AFC and AVC systems.

Club News

Edgware Short-wave Society

Headquarters: Constitutional Club, Edgware.

Meetings: Wednesdays at 8 p.m.

Hon. Sec.: Mr. F. Bell, 118, Colin Crescent, Hendon, London, N.W.9.

Three more members have now obtained transmitting licences, making a total of 18 fully licensed members of the club. Several other members are applying for licences. At the debate held on May 10th on "Phone v. CW" it was agreed by all that CW and phone should occupy separate parts of the amateur waveband, CW having two-thirds of the available ether space.

Future activities include a lecture by Dr. Smith on "Telcon Cables," a 5-metre field day and the R.S.G.B. field day.

Hoddesdon and District Radio Society

Headquarters: Blairgowrie, Station Road, Broxbourne, Herts.

Meetings: Second and fourth Wednesdays in the month at 8 p.m.

Hon. Sec.: Mr. T. Knight, Caxton House, High Street, Hoddesdon, Herts.

On May 10th Mr. Jackson, of Bishop's Stortford, gave a talk on television and demonstrated his home-constructed receiver. On May 21st there was a 1.7-mega-

Medway Amateur Transmitters Society

Headquarters: The Navy Wives' Club, Dock Road, Chatham, Kent.

Meetings: Tuesdays at 8.15 p.m.

Hon. Sec.: Mr. S. A. C. Howell, "Veronique," Broadway, Gillingham, Kent.

The "hamfest" held on May 10th was attended by amateurs from many parts of Kent. G2IG gave a talk on television, and G6WY dealt with the use and misuse of the amateur bands.

The transmitter is now complete and it is hoped that the Society's licence will be granted very soon.

Salisbury and District Radio Society

Headquarters: St. Mary's School, Barkers Lane, Sale, Lancs.

Meetings: Thursday evenings.

Hon. Sec.: Mr. S. C. O. Allen, 31, Ennerdale Drive, Ashton-on-Mersey, Lancs.

At the last meeting a letter was read from Sir Edward Grigg, the M.P. for the Altrincham division, replying to the recent resolution passed by the Society calling for an extension of the television service to the north. Sir Edward promised to do all he could to support the resolution.

Slough and District Short-wave Club

Headquarters: 35, High Street, Slough, Bucks.

Meetings: Alternate Thursdays at 7.30 p.m.

Hon. Sec.: Mr. K. A. Sly, 16, Buckland Avenue, Slough, Bucks.

At the last meeting the main item of interest was a demonstration by a member of high-voltage electrical phenomena. Three members have enlisted in the Territorial Army, including Mr. R. J. Sly, who has, therefore, been forced to resign the position of hon. secretary. A successful junk sale has been held. The next meeting will take place this evening (May 25th).

UNBIASED

A Raw Recruit

I AM, as you well know, always willing and ready to help readers in their wireless troubles to the best of my ability, and nothing pleases me more than to see my breakfast table stacked high with technical queries, although I may say that these feelings are not always shared by Mrs. Free Grid, more especially when, as sometimes happens, the whole pile topples over on her as she is consuming her morning portion of filleted frogs, a new reducing diet which I am told is all the rage in certain circles at present.

There are, however, limits to my patience, and sometimes I must admit the queries irritate me very greatly, as many of them betray a crass ignorance of the elementary principles of radie to a degree which I could hardly believe possible in these enlightened days. One letter which I found in my postbag the other morning betrayed exceptional lack of knowledge, and although it was not of a technical nature it revealed such amazing ignorance of the ways of the world of wireless in general that I feel constrained to mention it to you.

Briefly, my correspondent told me that he was engaged in the construction of a new receiver, and had duly ordered all the components, most of which had arrived, but that he was completely hung up in his constructional work by the fact that a

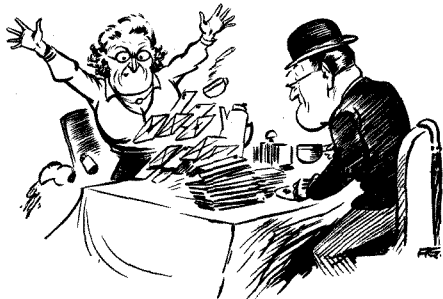

Toppled over on her.

certain tuning condenser had not yet turned up. "It is now ten whole days since I ordered this component," he wrote, "and not only has it failed to arrive but I have not received one word of explanation from the manufacturers concerning this unheard-of delay. I trust, therefore, that you will not only write to this manufacturer on my behalf but will give due publicity to this monstrous state of affairs in the pages of *The Wireless World*."

I think I need hardly say that I was amazed at the contents of this letter, and it was not until I came to the postscript that I was vouchsafed an explanation. "I think I ought to mention," my correspondent wrote, "that I am a newcomer to wireless." This, of course, explains everything. "To know all is to forgive

all," as the old wisecrack has it, and I freely forgive him.

My correspondent has a lot to learn yet of the weird ways of our wireless manufacturers. Ten days, indeed! Perhaps it will help him if I tell him that I am still awaiting delivery of a marvellous new crystal which I saw favourably mentioned in the editorial columns of *The Wireless World* as far back as 1926. "Ananite," it was called, and when I ordered it I was told that the demand exceeded the supply with the result that the whole factory output was sold for some time to come and I might, therefore, have to wait a considerable time for delivery. I am still waiting!

A Fishy Story

I DARESAY that most of you noticed the picture published recently in this journal (p. 421, May 4th) of a dog with a small receiver and loud speaker strapped to his back. However far the dog strays from home, its owner has only to speak into the microphone of his home-built transmitter and he can summon the animal home. According to the reading matter underneath the picture, the dog and its owner reside in Sydney, but as the four towns of this name are situated many thousands of miles apart, and the writer very skilfully omitted to say which one he meant, I was prevented from sending a telegram of protest to the authorities of the place concerned.

If this sort of thing is allowed to go unchecked abroad it will not be very long before it spreads to this country, and we shall have a new source of interference to contend with. It was not for some considerable time that it dawned on me that several of the cats wandering about my neighbourhood and belonging to a rather vinegary-looking spinster carried suspicious-looking bundles on their backs, bundles which I had always taken to be merely superfluous clothing which some spinsters insist on inflicting on their unfortunate pets.

Needless to say, I lost no time in impounding one of the cats which I found wandering about in the neighbourhood and quickly removed its bundle of clothing, expecting to find a miniature battery portable and loud speaker. To my surprise, however, I came across something very much more serious which puzzled me for a long time. It was nothing more nor less than a miniature flea-power USW transmitter. I use the expression flea-power in a purely figurative sense, of course, in order to convey an idea of the smallness of the power employed and not to indicate that, by some ingenious system, power was obtained from the fauna in the cat's fur.

I was very puzzled for a long time, and

By FREE GRID

even more so when I found out by listening in on my USW receiver that a long dash was being sent out automatically every few seconds. I lost no time in impounding all the other similarly clad cats in the neighbourhood and it was due, I suppose, to the fact that some tittle-tattling neighbour must have seen me that eventually I found a policeman on my doorstep.

It appears from the explanations that were given that the transmitters were the property of a scientific investigator who is lodging in the spinster's household, and is carrying out DF research work in connection with A.R.P. The cats have been chosen because they are first-class nocturnal wanderers, and it was just this sort



Suspicious-looking bundles.

of thing that was wanted to enable the investigator to check up on his DF experiments. For the life of me I cannot think what DF has got to do with A.R.P.; in fact, it all seems very fishy to me, almost as much so as the state of my laboratory after my feeding the cats on their favourite diet during their few days' enforced stay with me.

After 17 Years

I AM delighted to learn that after all these years of radio exhibitions it has been decided that this year there shall be a technical section. Apparently the matinee idols are still to be retained on the ordinary stands in order to give the women and children something to look at while father is having a quick one in the technical section. I fully realise that we do not want the technical part of the show jammed up with people who have come merely to see the fat lady and other sideshows, but if the technical section is to be made a *sanctum sanctorum* of men, as I learn, it will only lead our womenfolk to think that the technical experts whom we go to consult about our mixer problems are brassy blondes, more used to drink-mixing than frequency-mixing.

The B.B.C.'s German News Bulletins

ARE THEY RECEIVABLE ON THE "VOLKSEMPFÄNGER"?

AS the average German broadcast receiver is well known to be of lower sensitivity and selectivity than its British counterpart, most readers will have wondered whether the B.B.C.'s broadcasts in the German language have been successful in "getting over." A correspondent in Germany has, therefore, been commissioned to make a test under ordinary conditions with the two most popular German sets.

SOME doubt has been expressed in certain quarters as to whether the B.B.C.'s news broadcasts in the German language are really serving their purpose in putting the British point of view before the German man-in-the-street. It is not a question of whether the text of the bulletins is suited to the particular psychological make-up of the ordinary German citizen—that is another matter rather outside our province—but whether they can be heard at all having regard to the simple type of receiver commonly used by many of the inhabitants of Germany. It was in order to answer this question that a special correspondent of *The Wireless World* was commissioned to conduct certain receiving tests in Germany, the results of which we detail herewith.

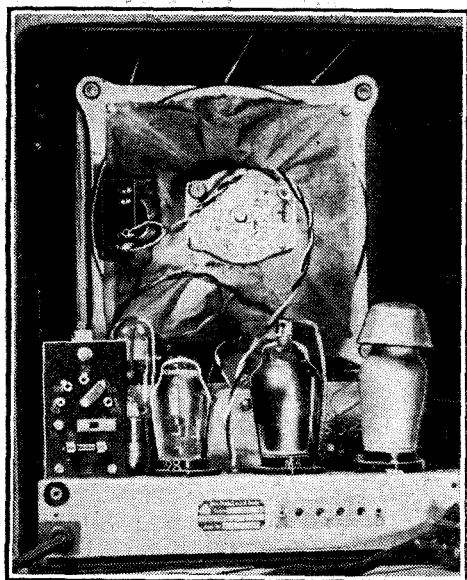

The Volksempfänger, shown here, has many refinements not found in the Kleinempfänger, including a separate output valve.

Probably everybody has heard of the Volksempfänger or "People's Receiver," and the reason why it was put on the German market, namely, to bring wireless reception within the limited means of the great majority of the population. From the fact that it was found necessary to market this cheap receiver, which for mains operation costs only £3 15s., it may be safely assumed that there was a crying need for it, or, in other words, that many

The Volksempfänger and the Kleinempfänger compared. Both are straight-forward detector AF receivers.

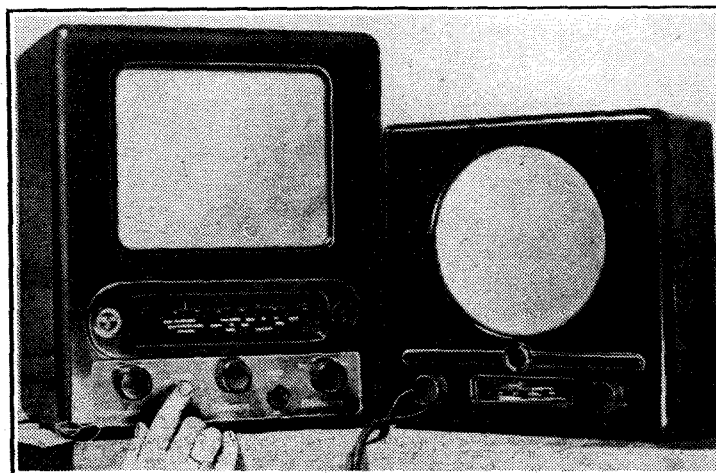

Germans could not, or would not, pay any more. That this assumption is more than justified is proved by the fact that it has been necessary to produce a still cheaper receiver, which is called the Kleinempfänger, or "little receiver," and can be obtained for thirty-five shillings.

Now it needs very little effort of the imagination to realise that, at the prices mentioned, the Volksempfänger and the Kleinempfänger must be very simple instruments indeed, without any pretensions to sensitivity and selectivity, but nevertheless adequately fulfilling the purpose for which they were mainly intended, namely, to enable the population to listen in to the political pronouncements of the German authorities. These are, of course, always simultaneously broadcast by all stations on important occasions, thus enabling them to be heard even by the owners of the Kleinempfänger, which is intended to be very little more than a local-station receiver. These receivers, being of the simple regenerative detector-AF type, cannot be used for foreign-station listening without a certain amount of juggling with the reaction control.

The Sets on Test

There are, of course, a large number of ordinary superhets sold every year in Germany, but there is rather a big gap between the £3 15s. Volksempfänger, and the cheapest superhet which costs nearly £11, and, although there is evidence to show that an astonishing number of the German working class do possess these more sensitive receivers, there must be a far greater number who do not, otherwise the Volksempfänger and the Kleinempfänger would not be necessary. Within their obvious limitations, these sets are effective enough from the sensitivity and selectivity points of view, but they are, of necessity, far behind the ordinary superhet in these respects.

With regard to the actual tests, both sets were tried out in a Berlin flat, using an indoor aerial; conditions which are fairly representative of those under which town-

dwellers in Germany have to use wireless. The Kleinempfänger, although surprisingly sensitive, failed to bring in any British station during normal broadcasting hours. An outdoor aerial would probably have remedied this so far as actually hearing British stations was concerned, but the background from the local transmitter, which was rather annoying even when using the indoor aerial, would have rendered reception impracticable, without careful adjustment of an external wave-trap. After the German stations had closed down, Droitwich and one medium-wave transmitter were the only worthwhile transmissions heard from this country.

The Volksempfänger, as might be expected, did somewhat better. The North Regional station was received during the time that the German stations were on the air, but our correspondent points out that,

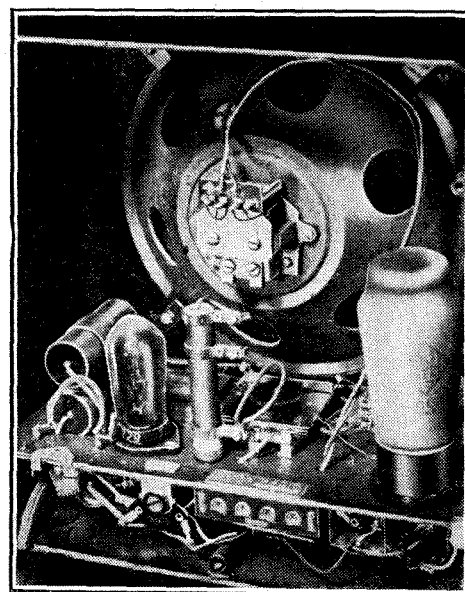

Fig. 3.—The Kleinempfänger employs one multiple valve and a mains rectifier.

on any set, the reception obtainable from this station varies greatly from day to day. Late at night the London and Northern Ireland Regional stations were heard. Droitwich was also picked up, but this station's transmissions were, as they

The B.B.C.'s German News Bulletins—

usually are, marred by considerable Morse interference.

The important point to remember is, however, that tuning was done by somebody who has had considerable experience in using many types of wireless receiver for several years past, although, on the other hand, our correspondent reports that the necessary tuning was well within the capabilities of the average completely non-technical citizen. He also states that, as might be expected in the case of these cheap sets, the various stations do not always come in at the same spot on the dial but vary with the adjustment of the reaction control.

Bearing all these facts in mind, therefore, we have to ask ourselves whether the average German citizen would bother to

tune in the British transmissions? The ordinary British listener of to-day certainly would not do so in the same circumstances, but we must remember that the average German is far more painstaking than ourselves and, in addition, has not been pampered with a surfeit of superhets and push-buttons as we have. Also it must not be forgotten that there is a considerable number of country-dwellers in Germany who, by reason of their remoteness from a powerful local transmitter, and their facilities for erecting a good outdoor aerial, would have little difficulty in receiving the British transmissions.

Even making these allowances, however, we are reluctantly drawn to the conclusion that the B.B.C. broadcasts do not "get across" to the bulk of the German population as well as they might do.

erected in the Midlands will not by any means be the last. I would therefore suggest that there is no time to be lost in examining a form of communication of which little is yet known in this country.

HOWARD HEATON,

Radio Correspondent,
Sunday Mercury, Birmingham.

Voice of the State

I HAVE read with interest your remarks in *The Wireless World* of May 11th, and regret you should find yourself advocating a form of censorship. As things stand, the B.B.C. provides the only news service without partisan politics. A Press review, although desirable, would not adequately replace the present news service.

You allege that the average man thinks that the B.B.C. speaks for the Government, but are not you yourself labouring under a worse misconception? The Government under the British Constitution is *not* the State. Furthermore, the B.B.C., to my mind, is, and rightly, the voice of the State.

Its job is to speak for every section of society in this country and to provide an unbiased foreign news service on the spot, not six or twelve hours late in the shape of a Press review. The average man does not want the B.B.C. to become the voice of the Government, as is the case in the totalitarian States.

If confusion does exist, it would be a simple matter to broadcast official communications separate from general news.

Uxbridge, Middx. JOHN GREGORY.

Letters to the Editor

The Editor does not necessarily endorse the opinions of his correspondents

Condenser Impedance

I WAS very glad to notice Mr. M. G. Scroggie's letter in your issue of May 18th concerning my article in the preceding number.

A careful check on the calculated inductance of straight wires did not indicate the discrepancy in the resonant frequencies as suggested by Mr. Scroggie, but a further search revealed that the formula used included a printing error which accounted for the discrepancy. I must apologise for this unforeseen error and hasten to append herewith a cor-

Revised graph showing the resonant frequency of various capacities with 20-SWG leads of lengths up to 20 cm.

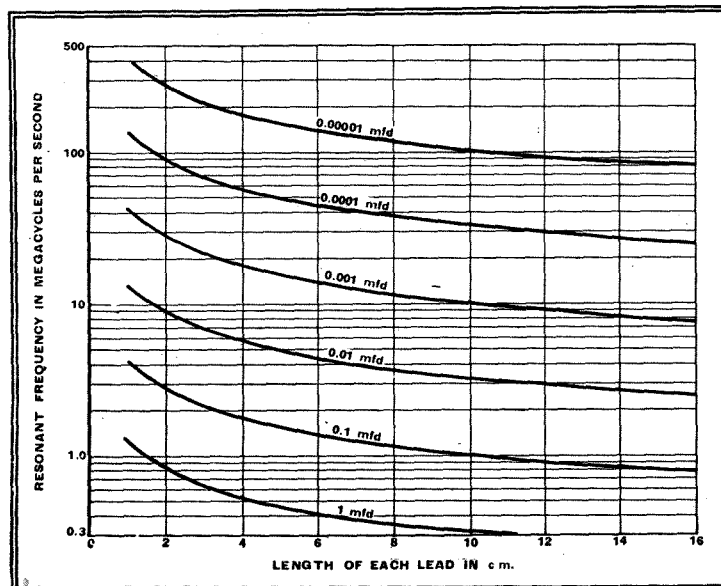

While the operation of frequency-modulated broadcasting stations may not be practicable at the present time, an immediate use for this system suggests itself. I refer to the provision of a radio link between Alexandra Palace and the television trans-

mitted family of curves with which I trust Mr. Scroggie will agree.

For his and readers' information they are computed on the base of negligible mutual inductance between the wires, which are assumed to lie along the longitudinal axis of the condenser itself. The main object of the article was to point out that the so-called non-inductivity of a tubular condenser is unimportant, since the connecting leads themselves are by far the greatest contributors to this property.

F. R. W. STRAFFORD.

Enfield, Middx.

Relaying Television: Use of Frequency Modulation

THE articles by "Cathode Ray" and by your New York Correspondent on frequency modulation or, as it is sometimes called, phase modulation are of great interest.

mitter which it is proposed shall be erected in the Midlands immediately the Television Advisory Committee have concluded their deliberations.

There are many advantages in using frequency as opposed to amplitude modulation for this purpose. The installation and running costs are likely to be minimised owing to the low power and greater range of the former type of transmitter. Secondly, the quality is likely to show a considerable improvement, due to the absence of atmospheric and interference. Thirdly, the greater range might easily reduce the number of relay stations or "repeaters" required between any two points.

It may be said that there is no record of frequency modulation having been used for television purposes and that there is not sufficient time available to develop it. To this I would reply there is probably ample data available in America for the asking; and, further, that the television station to be

Shaver Interference

YOUR correspondent in *The Wireless World* of May 11th, Mr. W. H. Pierce, has my sympathy. I am keen on ultra-short wave reception and I use a Philips 362A. Recently I was given an electric shaver, and it certainly caused a lot of interference. I have since found that a 0.01-mfd. condenser across the points completely eliminated all interference.

My razor was fitted with a small condenser, but it is not connected across the points.

If my next-door neighbour was using an electric shaver I should volunteer to fit a condenser free. It would be well worth it.

Southampton. J. A. YEARSLEY.

Designing a School Receiver

I SUBMIT the following comments on the design for a school receiver as proposed by "Assistant Master" in your issue of May 11th:—

(a) Arrange each section of the set on separate metal baseboards. (I have used with success thin sheet metal, either aluminium or zinc, fitted to wood bases $\frac{3}{16}$ in. thick, the thin metal being easy to work by hand, either drilling or punching.) As ventilation is necessary, the glass covers would have to be removed when the equipment is used, or, alternatively, the front and top could be of glass, with metal gauze (for free air circulation) for the sides.

(b) The circuit suggested should be very suitable, especially for high-quality reproduction, and the tone-control stage most desirable. For the resistance capacity-coupled amplifier *The Wireless World* one, described in the issue of April 3rd, 1936, should form a suitable basis.

(c) As the accuracy desired is not always easy to obtain, except in well-equipped workshops devoted to the manufacture of radio apparatus, it would be more desirable

to purchase the inductances than to wind them.

(d) Good soldered joints should be made where possible.

(e) The valves should be 4-volt types, all indirectly heated, except the power valves in the audio-frequency output stage, which might be directly heated 4-volt types.

(f) Heater current obtained from large-capacity accumulators is quite suitable.

(g) High tension from large-capacity cells is very good, if attention is paid to them. Interference (mains-borne) is greatly reduced by their use.

(h) The output suggested would enable good-quality reproduction to be obtained, without working the equipment near "full-out" position. Also, several loud speakers could be used, with adequate volume per speaker, if this was required, as it sometimes may be.

The use of metal baseboards (not chassis) not only leaves the set open for inspection and demonstration as desired, but also cost is reduced, and construction is easier for persons not accustomed to this kind of work.

The tone-control unit described in *The Wireless World* of January 6th, 1938, should be a suitable type. KEN. G. PAYTON.

West Bromwich.

Paper Records

SIR JOHN FALSTAFF said: "I can find no remedy for this consumption of the purse." His wail must be echoed by many nowadays who like to have good gramophone records. The announcement about "Paper Records" in your issue of May 11th gives one hope. They seem to be just what the doctor ordered. Let us hear more of the "Paper Phonogram." It ought not only to provide the remedy Falstaff sought, but do much more, to wit: (1) cure needle scratch; (2) allow a full bass; (3) and full-range treble; (4) save the exasperating changing of records and needles in the longer pieces of music and for speech recording.

Think also of the gain to schools, lecturers and for instructional purposes of all sorts. W. McKECHNIE (Lt.-Col.).

Hastings.

Random Radiations

By "DIALLIST"

Concert Pitch

WELL, one thing at any rate has at last been standardised the world over, and the B.B.C. can claim a large share of the credit. At a conference between experts forming a committee of the International Standards Association, held recently at Broadcasting House, it was decided that the "A" of the treble clef, used by orchestras as a tuning note, shall have a frequency of 440 cycles a second. Up to now different countries have had their own standards, varying from 435 to 442. With the A at 440 c/s, middle C becomes 262, D 294, E 331, F 350, G 392, and B 495. Once the standardised tuning comes into force, as presumably it will almost immediately, those with good ears will be able without trouble to assign an exact frequency to loud speaker and cabinet

resonances that they track down. Resonance hunting has always been rather fun; it will be still more interesting with a standard pitch for concert transmissions. I wonder, though, whether the next series of measurements made with the cathode-ray oscillograph of Drs. van der Pol and Addink¹, will show that orchestras are strictly keeping the new pitch!

Whiskrospherics

MY deepest sympathy goes out to Mr. Pierce, of Beckenham, Kent, who reported in a recent issue of *The Wireless World* that a neighbour's electric razor was completely blotting out morning reception of the 14 Mc/s Australian and New Zealand stations. I have heard that the motors used in razors are very difficult to suppress. One wonders why those who make the things didn't have a bit of research done before putting them on to the market with a view to seeing whether an innocuous motor couldn't be evolved. Couldn't a small induction motor be designed to do the job quite well? One thing I do know is that the use of interference-causing motors is having some adverse effect on sales. Several people who refuse, in the interests of wireless, to have radiating appliances in their homes, have told me that they have sent them back after trial. My own good deed, as a practical contribution to the anti-interference campaign, was to turn down my better half's suggestion of giving me one for a birthday present.

Adverse Conditions

A PITY—wasn't it?—that bad radio conditions accompanied the relay from Quebec of the landing of the King and Queen from the *Empress of Australia*. I hadn't been listening to it long before I began to congratulate myself that it wasn't my job to work the controls at the receiving end. That must have been a ticklish business, for there was a nasty little morse signal that kept on drifting in and out. Luckily the fading and the various forms of interference were not bad enough to spoil the relay. When the signal went right out just as the commentator announced that the King and Queen were about to step on to the gangway, I feared the worst. Luckily it came back again in time and we were able to hear the cheering and the twenty-one gun salute as His Majesty's foot touched Canadian soil. Later I tuned in direct the N.B.C. commentary on the 15-Mc/s band. It was weak, fading badly and also suffering from the unwelcome visits of a morse signal. What a nuisance those morse transmissions are on the higher-frequency short-wave bands! There don't seem to be many of them as a rule; but as sure as eggs are eggs if there's one about it will be on the station that you most want to hear.

¹ "Orchestral Pitch," by van der Pol and Addink, *The Wireless World*, May 11th, 1939.

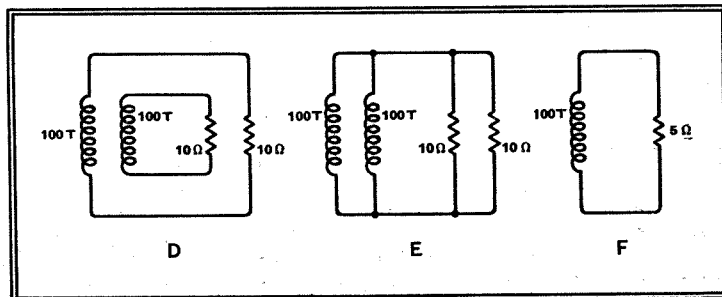

More Power to Their Elbows

THE R.M.A., I observe, has appointed a small committee of its members to conduct a campaign against interference. I am all in favour of small committees: with larger ones it's always difficult to "cut the cackle and come to the 'osses"; small ones can get things done. I hope that this committee will take the line that the best way to get rid of undesirable things is to strike at their roots. With that end in view they might well launch their campaign by bringing home to manufacturers and others connected with the radio industry the folly (to put it mildly!) of turning out domestic electrical appliances that produce interference and then of urging wireless shops to sell them. It's of little use for the man-in-the-street to be encouraged at one moment to do his bit against interference if at the next he is urged to buy and to use in his home apparatus that is certain to cause it in his own house, and very likely in those of his neighbours as well. Nor will other manufacturers give much heed to any protests that the R.M.A. may make unless it can show that it has already cleaned up its own stables.

Theatres of the Future

THE present position of television in the ciné theatre programmes, in which it provides more or less brief interludes between films, rather reminds one of what used to be done in the early days of the cinematograph. Those whose memories stretch back into the early nineteen hundreds may remember that before there were any regular ciné theatres, the "bioscope" was often used to provide one or more turns in music-hall programmes. Television entertainment is a bit better than that and on the big screen it is not just a turn. I shouldn't be surprised if the television theatre, with full-length programmes, is one day as common as the ciné theatre is now.

HENRY FARRAD'S SOLUTION

(See page 486)

FRED NEW'S equivalent rearrangements from A to C are quite sound so far as they go, but they do not go far enough. C can be redrawn as D here, and as each winding generates the same voltage there is no reason why their ends should not be joined (E). So far as anybody knows, the two 100-turn windings may be wound close together, perhaps in the same outer covering. In fact, they may just be two strands in one piece of flexible wire, so can now be regarded as one and the same winding, having 100 turns. Meanwhile the two 10-ohm loads, being in parallel, are equivalent to one 5-ohm load. So finally we arrive at F, which justifies the square root rule, for compared with A there is a quarter the load

impedance across half the number of turns.

The fallacy consisted in considering the two halves of C separately. One half, with 10 ohms across 100 turns, is, of course, not equivalent to any of the arrangements A-F.

Recent Inventions

The British abstracts published here are prepared with the permission of the Controller of H.M. Stationery Office, from Specifications obtainable at the Patent Office, 25, Southampton Buildings, London, W.C.2, price 1/- each.

TELEVISION SCREENS

IN order to intensify the output from a cathode-ray tube, it has been proposed to use a relay arrangement in which the light produced on a fluorescent screen is subsequently projected on to a light-sensitive screen, preferably of the mosaic-cell type, so that the resulting electric image forms the source of a new stream of electrons.

The Figure shows the construction of a double screen used for this purpose. It consists of a group of small glass or quartz rods R, which are laid side by side in parallel formation and bound together by waterglass. The near end or face A of each rod is coated with fluorescent material F, whilst the opposite end B is covered with light-sensitive material M, so that collectively they form a mosaic screen.

In this way the fluorescent light

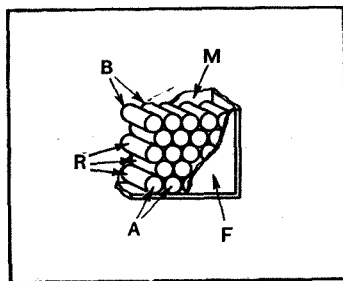

Method of increasing the intensity of the visual output of a cathode-ray tube.

produced at F by the impact of the original stream of electrons is conveyed to the mosaic cells B by total internal reflection inside each of the rods, and the usual dispersion losses are minimised.

Baird Television, Ltd.; V. A. Jones and K. A. R. Samson. Application date July 29th, 1937. No. 499785.

RADIOGONIOMETERS

A CONVENIENT arrangement is described for finding the "sense" as well as the direction of a distant beacon station on a radiogoniometer. After the bearing line has been ascertained in the ordinary way, it is usual to apply the pick-up voltage from a vertical or non-directional aerial, so as to convert the figure-of-eight curve given by the frame aerial into a cardioid curve. The latter, having only one critical "minimum," instead of two, then serves to show on which side of the bearing line the distant transmitter is located.

According to the invention, the usual search coil of the radiogoniometer is replaced by two "crossed" coils. One of these is used when the bearing line is being taken, and is then switched out and replaced by the second coil (which is coupled to a vertical aerial) for "sense" determination. The control switches are conveniently mounted on the hand wheel used for rotating the search coil, the phase of the aux-

iliary "vertical" aerial being reversed by a press ring of the kind used on the steering wheel of a motor car for sounding the horn.

C. Lorenz Akt. Convention date (Germany), May 14th, 1937. No. 499708.

RECEIVING ULTRA-SHORT WAVES

A RECTIFYING circuit for handling very short waves is designed to avoid any perceptible damping effect on the tuned input circuit. With very short waves, the transit time taken by the electrons to pass from the cathode to the control grid sets up an out-of-phase relationship with the incoming signals, and so produces a grid current which tends to damp the selectivity of the tuned RF circuit.

According to the invention, a two-grid valve V is operated on the Barkhausen-Kurz principle of a negative anode and positive grid. The tuned input circuit LC is connected across the cathode and anode, the latter being negatively biased through a resistance R. The grid nearer the anode is positively biased through a resistance R₁, and the rectified signals are tapped off from a resistance R₂ connected to the second grid. The resistance R₂ presents a considerable impedance to the rectified current.

The only damping effect which can occur is that due to the absorption of the energy required to accelerate the electrons flow-

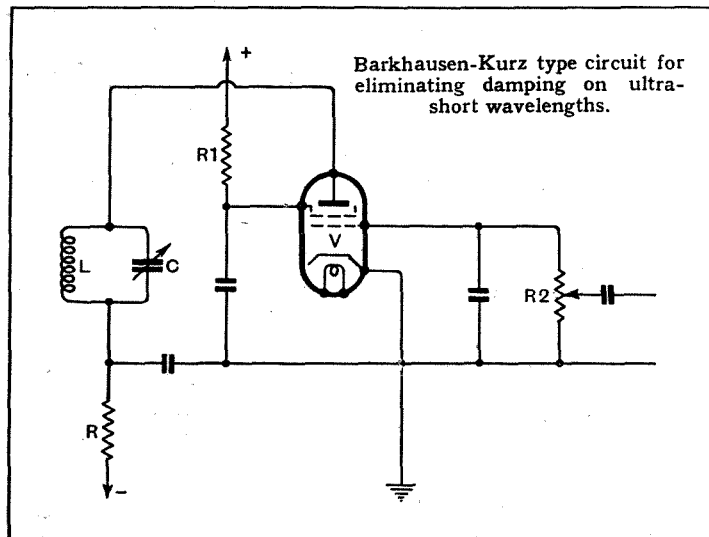

ing through the valve, and this is extremely small.

N. V. Philips' Gloeilampenfabrieken. Convention date (Germany) July 10th, 1937. No. 501850.

USW FILTER CIRCUITS

A HIGH-FREQUENCY "transmission line" such as a pair of parallel or coaxial conductors,

a quarter-wave long, presents a high impedance to frequencies corresponding to that wavelength, as well as to odd multiples of it.

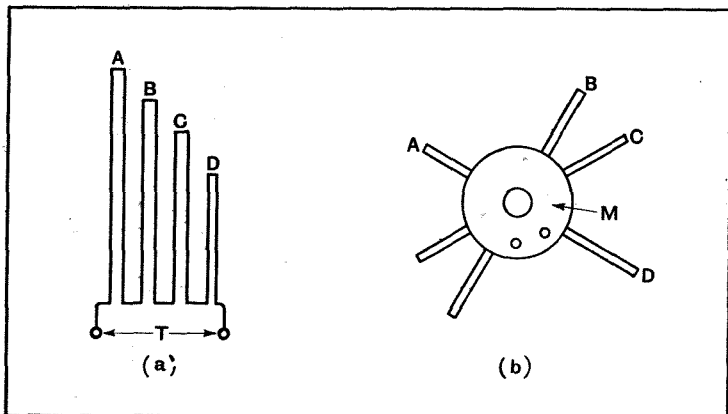

Use of quarter-wave coaxial or parallel conductors as rejectors for waveband filtering.

This principle is utilised to construct a filter circuit covering a selected band of wavelengths.

As shown in Figure (a), a number of quarter-wave units A, B, C, D are connected in series across a pair of terminals T. Each is short-circuited at the far end, and each acts as a resonant choke or rejector circuit at the frequency for which it is designed, so that the combined unit serves as a waveband filter. A similar arrangement of half-wave elements

MUTING CIRCUITS

A MUTING circuit is used to keep a receiver silent until a worth-while signal, of predetermined threshold strength, removes the bias and brings the loud speaker into operation. The object of the invention is to carry out this operation in a more clear-cut manner than usual.

For this purpose, a glow-discharge tube is inserted in series with the impedance across which the incoming signal builds up the voltage required to remove the muting bias. At the threshold point, the signal voltage reaches a strength sufficient to cause the discharge tube to strike. This removes the muting bias in a clean and effective manner, and allows the incoming signal to be promptly reproduced.

Marconi's Wireless Telegraph Co., Ltd. and O. E. Keall. Application date, July 28th, 1937. No. 499774.

SHORT-WAVE GENERATORS

ANY variation in the mains supply voltage to an ultra-short-wave generator valve tends to make the frequency of the output fluctuate. The invention is concerned with ways and means of preventing this.

It is pointed out that such frequency variations are due to changes in the space charge set up around the control grid of the valve. A rise in the voltage applied to the cathode, for instance, results in increased emission and a higher density of space charge. On the other hand, an increase in the positive voltage on the grid nearest the control grid tends to draw away the accumulated electrons, and so lowers the space charge.

A circuit arrangement is described in which one of these effects is made to counterbalance the other, thus keeping the capacity between the control grid and cathode constant at all times. This stabilises the generated frequency in spite of variations in the supply voltage.

NV. Philips Gloeilampenfabrieken. Convention date (Germany) March 8th, 1937. No. 499546.

with open ends can be used for alternating currents when no D.C. component is present. Fig. (b) shows a practical arrangement in which the different units A, B, etc., are mounted to project radially from a pair of clamping discs M.

Belling and Lee, Ltd., and F. R. W. Stafford. Application date July 21st, 1937. No. 499590.