

The **Wireless** **World** ^{6^D}
THE PRACTICAL RADIO & TELEVISION JOURNAL

Thursday, June 1st, 1939

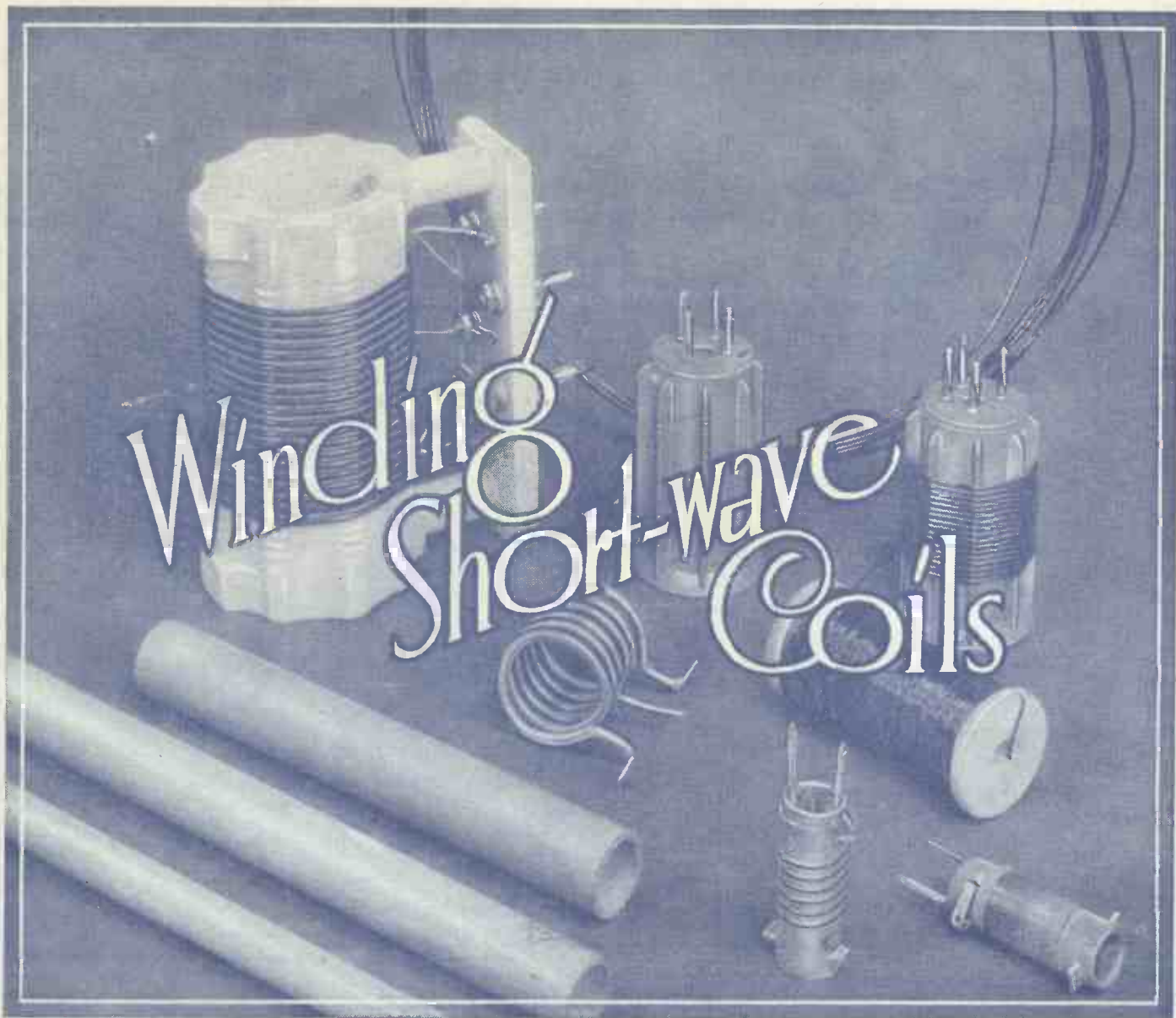

SIXTH EDITION—REVISED AND ENLARGED

**HANDBOOK of
TECHNICAL INSTRUCTION
for
WIRELESS TELEGRAPHISTS**

by **H. M. DOWSETT**
(M.I.E.E., F.Inst.P., M.Inst.R.E.)

This standard handbook, completely revised and enlarged, is planned primarily for the use of wireless operators, whether prospective or actual. It is virtually a complete theoretical course for students wishing to qualify for the Postmaster-General's Certificate of Proficiency

CONTENTS INCLUDE:

The Electric Charge and the Condenser—The Condenser in Practice—Direct Current and Ohm's Law—Scalar and Vector Quantities and Curve Plotting—Primary Batteries—Accumulators—Magnetism—Electro Magnetism—Self-Induction—Dynamo Electric Machines—Measuring Instruments—Switchboards and Switchgear—Alternating Current Effects, and Vector Diagrams—Alternating Current Fundamental Formulae—Alternating Current Generators—Alternating Current Motors and Transformers—Damped Oscillations—Commercial Types of Spark Transmitter—Aerials and Radiation—Simple Receiver Circuit and Crystal Detector—Thermionics and the Various Applications of the Valve—Depth Sounding—Valve Transmitters—Wavemeter and Transmitter Adjustment—Theory of Valve Receiver Circuits—Valve Receivers—Short Wave Aerials and Apparatus—Marine Direction Finders—Marine Audio Relay Service—Distress Call Apparatus—Lifeboat and Emergency Outfits—Trawler Apparatus—Maintenance of Marine Radio Installations and Possible Faults.

*618 pages, including Comprehensive
Index and 578 Illustrations.*

NOW ON SALE

PRICE 21/- By post 21/9

Foreign Postage 22/-

Obtainable from leading booksellers or direct from the Publishers:

ILIFFE & SONS LTD., DORSET HOUSE, STAMFORD STREET, LONDON, S.E.1

The Wireless World

THE
PRACTICAL RADIO
JOURNAL
29th Year of Publication

No. 1031.

THURSDAY, JUNE 1ST, 1939.

VOL. XLIV. No. 22.

Proprietors : ILIFFE & SONS LTD.

Editor :
HUGH S. POCOCK.

Editorial,
Advertising and Publishing Offices :
DORSET HOUSE, STAMFORD STREET,
LONDON, S.E.1.

Telephone : Waterloo 3333 (50 lines).
Telegrams : "Ethaworld, Sedist, London."

COVENTRY : 8-10, Corporation Street.
Telegrams : "Autocar, Coventry." Telephone : 5210 Coventry.

BIRMINGHAM :
Guildhall Buildings, Navigation Street, 2.
Telegrams : "Autopress, Birmingham." Telephone : 2971 Midland (5 lines).

MANCHESTER : 260, Deansgate, 3.
Telegrams : "Iliffe, Manchester." Telephone : Blackfriars 4412 (4 lines).

GLASGOW : 26B, Renfield Street, C.2.
Telegrams : "Iliffe, Glasgow." Telephone : Central 4857.

PUBLISHED WEEKLY. ENTERED AS SECOND
CLASS MATTER AT NEW YORK, N.Y.

Subscription Rates :

Home and Canada, £1 10s. 4d. ; other
countries, £1 12s. 6d. per annum.

*As many of the circuits and apparatus described in these
pages are covered by patents, readers are advised, before
making use of them, to satisfy themselves that they would
not be infringing patents.*

CONTENTS

	Page
Editorial Comment	503
Voltage-current Relationships	504
Light Amplifier	506
Problem Corner	506
Winding Short-wave Coils	507
American Loctal Valves	508
Cathode-ray Oscilloscope (Con- cluded)	509
Television Programmes	512
Transmitter Measurements	513
News of the Week	515
Aerial Masts (Concluded)	517
Unbiased	520
Readers' Problems	521
Letters to the Editor	522
Random Radiations	522
Recent Inventions	524

EDITORIAL COMMENT

Co-operative Service Guarantees

A Scheme from Denmark

ALTHOUGH we have not heard so much lately of the misdeeds of the unqualified (and often unscrupulous) service man who battens on the ignorance of the average broadcast set user, everyone knows that he still flourishes in our midst. As often as not his victims deserve little sympathy, as they are attracted into his clutches by specious promises of work to be done for nothing or else at an obviously un-economic rate. We are more concerned here with the bad effects of his misdeeds on the reputations of the many genuine service men who are trying hard to perform what is admittedly a difficult task, and one requiring a high degree of intelligence and knowledge, with the utmost efficiency.

Guaranteed Repairs

A scheme that should do much to enhance the standing of the service man, and at the same time react to the benefit of the public, is reported on another page by our Scandinavian correspondent. It appears that the Danish association, Radioteknisk Forening, has instituted a plan whereby it becomes responsible as a body for the quality of service work done by its members as individuals, and also for the fairness of the charges made. A guarantee label, affixed to the set after the repair has been done, bears the name of the association, to which presumably the customer will address any complaints that may arise in the event of his being unable to obtain satisfaction from the service man who carried out the work.

It would appear that this guarantee label might well fulfil purposes other than that for which it was primarily devised. In the first place the scheme should help to inculcate what may be described as a pride of craftsmanship, as the service man who uses it automatically tends to identify himself with his work and so to accept a personal responsibility for its excellence. Further, the scheme should tend to foster an *esprit de corps* among service men; anyone affixing a label to defective work would know that he ran the risk, not only of damaging his own reputation, but of lowering the standing of all his confreres in the Association.

Weeding Out the Unfit

Perhaps most important of all, a scheme such as that under discussion would have the effect of helping a strong and well-organised service association to weed out the inefficient and slipshod workers from its ranks. Obviously, if the association is liable to incur a monetary liability in respect of any members whose work is consistently unsatisfactory, it is in its own interest to terminate their membership. This natural bar to inefficiency would operate even more powerfully—and perhaps more fairly—than a stiff qualifying examination for membership of an association.

The confidence of the public in wireless servicing is unfortunately not so high as it might be, and we stress this matter because we believe that it is highly desirable from every point of view that the fullest confidence should be established. We shall watch the working of the Danish innovation with the greatest interest, and suggest that the possibility of modifying it to suit the conditions prevailing in this country is worthy of consideration.

Voltage-current Relationships

POINTS IN AC THEORY CLARIFIED BY THE OSCILLOGRAPH

By N. PARTRIDGE, B.Sc., A.M.I.E.E.

IT is common knowledge that condensers and chokes give rise to phase shift when used in audio-frequency circuits. That a choke and a condenser, used in conjunction, can be tuned to resonate at any required frequency is also generally accepted. But to get right down to fundamentals, do we all honestly understand just what these casual observations really signify? Without worrying about the mathematical aspect, let us take an oscilloscope and try to collect some clear ideas about the matter.

As a preliminary step we must see how the peculiar patterns produced by the oscilloscope may be interpreted, and here, the freehand curve of Fig. 1 will be use-

ful. The wavy line may represent an alternating current or a voltage. The straight line through the centre is the zero and points above it indicate a current or voltage in one direction (say positive), while points below it denote a current or voltage in the reverse direction (say negative). Time is to be imagined as marching along this line from left to right. Starting from the point A, the current (or voltage) rises in a positive direction, then falls to point B. From here it rises in a negative direction, and then falls again to point C. After this the process of alternate positive and negative pulses is repeated all over again. The complete story is told between A and C, the remainder of the curve being only a repetition of the same thing.

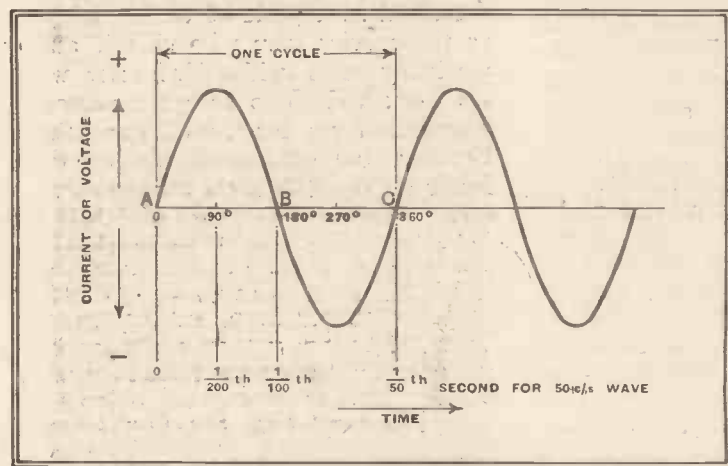

Fig. 1.—The nature of an alternating current or voltage.

This "complete story" is known as a cycle. It is, as the name suggests, a complete cycle of events, and the frequency tells us how many times per second this cycle of events is repeated. If the frequency of the observed wave were, say, 50 cycles per second, the distance from A to C along the zero line would represent

WITH the help of a series of oscillograms, several thorny points with regard to the relationships between voltage and current in various AC circuits are made clear.

current; when the voltage reaches a maximum so does the current. On the whole, it is a rather uninteresting demonstration. The next photograph (Fig. 2 (b)) shows a similar pair of curves taken with a condenser instead of a resistance (see Fig. 3 (b)). The larger curve (V) repre-

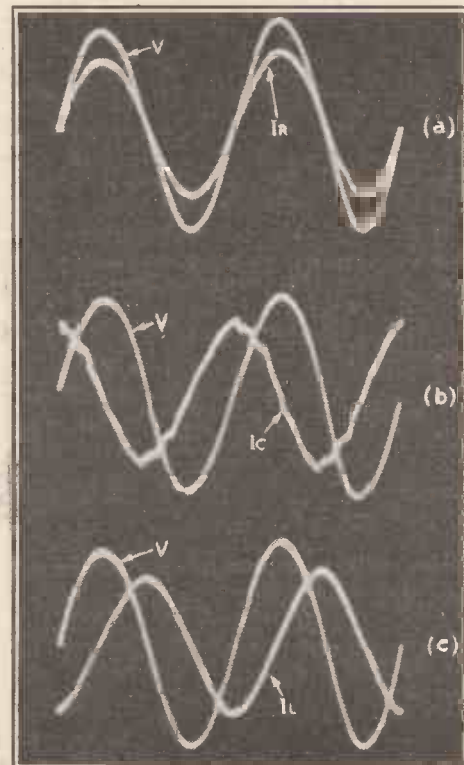

Fig. 2.—Relationships between current and voltage in simple circuits containing resistance, capacity or inductance.

sents the voltage as before, while the dented curve (I_C) is a trace of the current wave form. The rather second-hand appearance of the latter has been brought about by one of those unforeseen snags that go to make life more amusing. The supply voltage has a very small high-frequency harmonic content, probably due to tooth ripple in the alternator. The impedance of a condenser is inversely proportional to frequency, and, therefore, the harmonic will pass through more easily than the relatively low-frequency fundamental. The ripple in the current curve is only a magnified version of a corresponding ripple in the voltage curve too

small to be noticeable. This minor imperfection must be overlooked for the purpose of the present discussion. The major difference between Fig. 2 (a) and Fig. 2 (b) is that the current curve (I_C) has shifted a quarter of a cycle to the left, and is, therefore, ahead of the voltage curve (V)

Exhibit No. 1, which is Fig. 2 (a). This shows the voltage (V) and current (I_R) relationship in a pure resistance. The circuit from which these curves were obtained is shown in Fig. 3 (a). The oscillogram confirms what one would expect from a knowledge of Ohm's Law. The current is at all times proportional to the voltage. When there are no volts there is no

Fig. 3.—Circuit arrangements from which the various oscillograms were obtained.

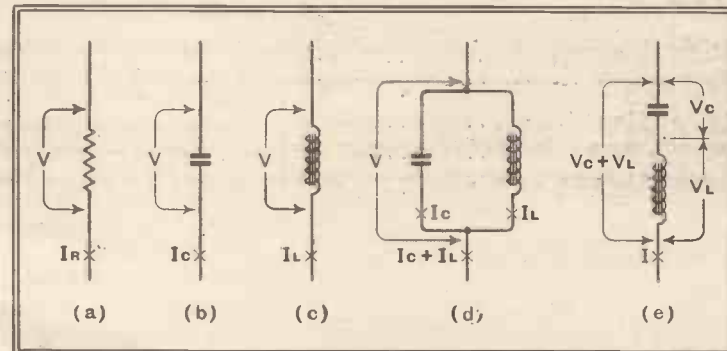

current; when the voltage reaches a maximum so does the current. On the whole, it is a rather uninteresting demonstration. The next photograph (Fig. 2 (b)) shows a similar pair of curves taken with a condenser instead of a resistance (see Fig. 3 (b)). The larger curve (V) repre-

Voltage-current Relationships—

by 90°. Our next job is to elucidate the mystery of its having got there.

When a constant voltage (DC) is applied to a condenser, current flows into it until the condenser is fully charged, then current ceases to flow, although the voltage may be still applied. A short-circuit across the condenser terminals will reduce the volts to zero, and, at the same time, cause a discharge current to flow. Changing the voltage across the condenser produces a charging or discharging current, while a steady voltage results in no change of charge and, therefore, no current.

In Fig. 2 (b) we can observe this process of charging and discharging taking place in time with the alternations of the voltage. Consider the condition a quarter of a cycle from the left of the oscillogram, i.e., where the current is zero and the voltage is at a maximum. The voltage is changing from a rising to a falling state, and for an instant between the two conditions it is constant. The condenser at this instant maintains a steady charge, and, therefore, current flows neither in nor out. For the next half-cycle the voltage falls, first to zero, then to a negative maximum. The condenser is consequently first discharged and then charged up in the reverse direction, hence the negative loop of the current curve. The quicker the change of voltage the more rapid will be the change of charge held by the condenser. Where the voltage curve is steepest as it crosses the zero line we find the greatest discharge current; i.e., a negative maximum to the current curve.

We are now at the negative peak of the voltage, and for an instant the voltage can again be regarded as constant. The cur-

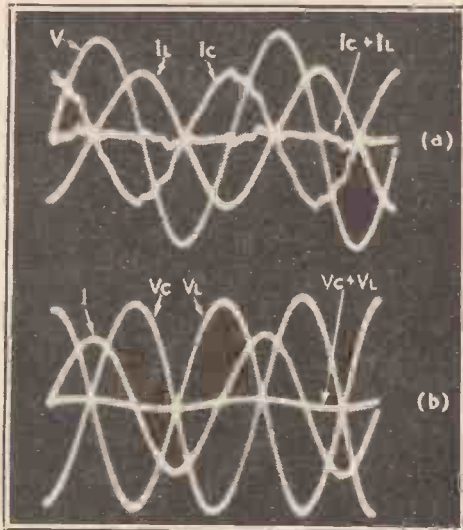

Fig. 4.—Oscillograms of voltage-current relationships in more complex circuits.

rent, therefore, falls to zero. For the following half-cycle the voltage returns to zero and then rises to a positive peak. During this time the condenser must be discharged and then charged in the original direction, a process resulting in the positive half-cycle of current which ends up at zero as the voltage reaches its maximum and instantaneously constant value.

Since the process has been reduced to one of charging and discharging the condenser, it is reasonable to assume that no power is being used up. Energy is absorbed by the condenser when it is charged, but during the following discharge it gives the energy back again. The truth of this can be seen from the oscillogram. Starting from the extreme left, for the first quarter-cycle the current and voltage curves are both positive. This indicates that power is being supplied to the condenser from the mains. The subsequent quarter-cycle has a positive voltage, but a negative current; therefore, power is being returned to the mains from the condenser. The exchange of energy from mains to condenser and vice versa is repeated four times in every complete cycle.

Inductive Circuits

So much space has been given to chasing the condenser current up hill and down dale that the corresponding curves obtained by substituting an inductance (Fig. 2 (c)) can have but brief mention. The current (I_L) this time has shifted to the right of the voltage curve, i.e., it lags by 90°. Again, no power is dissipated because the same exchange of energy from mains to the inductance and back again occurs as with the condenser, but with one important difference. During the quarter-cycle that power is being absorbed by the condenser, power is being given out by the inductance. Where the condenser curves are both of the same sign, the inductance curves are of opposite sign. This follows, since the condenser current (I_C) is a complete half-cycle out of phase with the current through the inductance (I_L).

Looking at the two oscillograms of Fig. 2 (b) and (c), the current curves are the inverse of each other. Tip the condenser current curve upside down, and it gives the current curve obtained from the inductance. This is very interesting because it looks as though the two currents would cancel each other if drawn from the same source of supply.

It is quite a simple matter to examine this possibility experimentally. The circuit diagram is shown in Fig. 3 (d), and all we require of the two components is that they shall each pass the same current when separately connected across the supply. The oscillogram of the various currents is given in Fig. 4 (a). The condenser current (I_C) is substantially the same as the choke current (I_L), but always in the reverse direction. The sum of the two (I_C and I_L) would be zero were it not for the irrepressible harmonic, which we are justified in ignoring.

This idea of a substantial current passing through both components while none comes from the supply is suggestive of magic; nevertheless, it is amenable to reason. When the voltage is first switched on a little packet of energy is taken by the circuit. From then on the choke and condenser play shuttlecock with it. When the choke gives out energy the condenser takes it in; when the condenser gives up the energy a quarter of a cycle later, the choke

receives it back again, and so on. It is not altogether correct to say that no power is drawn from the supply because a little energy is lost in the resistance of the choke winding and in the dielectric of the condenser. If these losses could be eliminated, literally no current or power would be dissipated. Then if the game were once started it would go on for ever, and the supply could be disconnected, since its only purpose was to provide the starting impulse.

In order to produce the above phenomenon the choke and the condenser must draw identical currents when individually connected to the AC source. This is the same thing as saying that they must have the same impedance at the frequency of the supply. And both these statements are equivalent to saying that the condenser and choke must be tuned to the frequency in question. A tuned circuit is nothing more or less than one in which the capa-

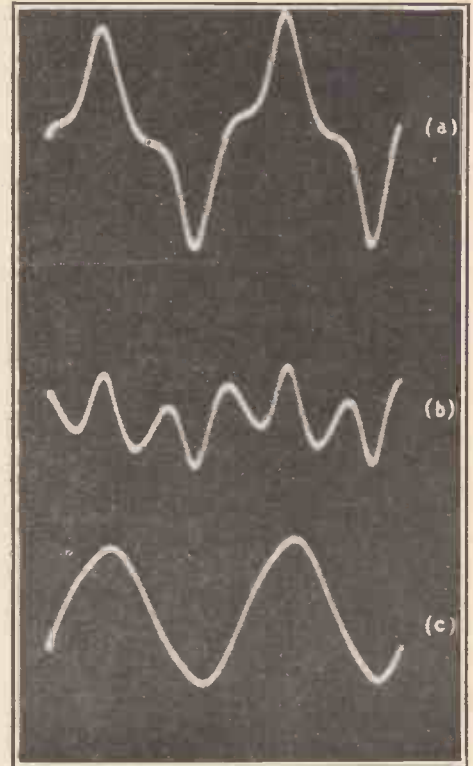

Fig. 5.—Waveforms with superimposed harmonics.

city takes in and gives out little parcels of energy of exactly the same magnitude as those needed by the inductance. The upshot of this is that the two partners (capacity and inductance) match each other perfectly and pass the energy back and forth without loss.

So far we have applied the same voltage to the components, but, by connecting them in series, we can assure the same current passing through both. The circuit of Fig. 3 (e) illustrates how this is done. The current must be in phase with itself throughout the circuit, and, therefore, the current in the condenser will be in phase with the current through the choke. Instead of keeping the voltage as a standard of reference, as in Fig. 2 (b) and (c), the condition now is that the current has become the standard. By moving Fig. 2 (c)

Voltage-current Relationships—

along until the current curve comes directly beneath that of Fig. 2 (b), it can be seen that the voltages are thereby pushed out of phase. They are equal and opposite.

The voltage oscillograms are illustrated in Fig. 4 (b). The large waves represent the voltages across the choke and condenser, while the almost straight line indicates the supply voltage. Being the sum of two equal and opposite voltages, the latter is practically zero. The analogy between the parallel and series circuits is very apparent. In the former the two currents add up to zero, while in the latter the two voltages combine to give the same answer.

The foregoing study is inclined to produce mental fatigue, and, in the manner of a not-too-serious schoolboy, one is tempted to end up by "larking about" with the apparatus available. Fig. 5 (a) shows a voltage waveform that is made up of a 50 c/s fundamental plus a considerable harmonic content. By juggling with the tuned circuit it should be possible to sort out the harmonics and separate them from the 50 c/s fundamental. This time deliberately instead of accidentally, as in the case of the intruding tooth ripple earlier on.

Filter Circuit

A parallel-tuned circuit draws no current from the supply, and, therefore, behaves like an open circuit at the particular frequency to which it is tuned. At higher frequencies the capacity passes more current and the choke less, so that the two no longer balance each other, and, therefore, the impedance falls below infinity. The arrangement of Fig. 6 gives hope of achieving our object. The circuit

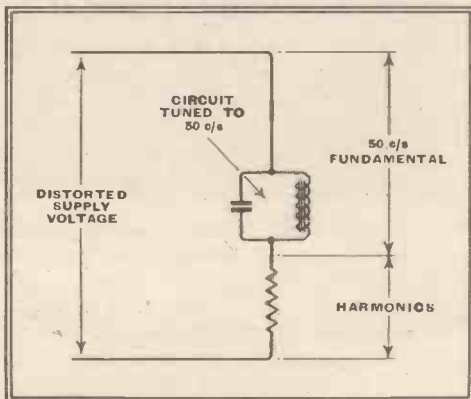

Fig. 6.—Circuit for separating harmonics from the fundamental frequency.

tuned to 50 c/s should prevent any current of this frequency from passing, but will allow the harmonics to go through. There is reason to anticipate that the voltage developed across the resistance will be almost entirely harmonics of 50 cycles. Fig. 5 (b) shows what was actually found. The third harmonic is the largest, but the fifth and seventh are also present, and are the cause of the irregular nature of the wave.

Fig. 5 (c) shows the voltage across the

tuned circuit. It is practically a pure 50-cycle wave with only a suggestion of harmonic left. Since the three curves of Fig. 5 are all to the same scale, the two lower ones should add together to form the original wave. Some readers might like to try it for this week's homework, in which case the Editor will probably excuse them from attempting the "Problem Corner" question!

Light Amplifier

REGENERATIVE PHOTO-CELL

THE point at which incident light is first converted into signal current by photo-electric action is one of the weakest links in the chain of television. The Iconoscope tube, with its "storage" screen of mosaic cells, goes some way towards restoring the balance, whilst the electron-multiplier offers still

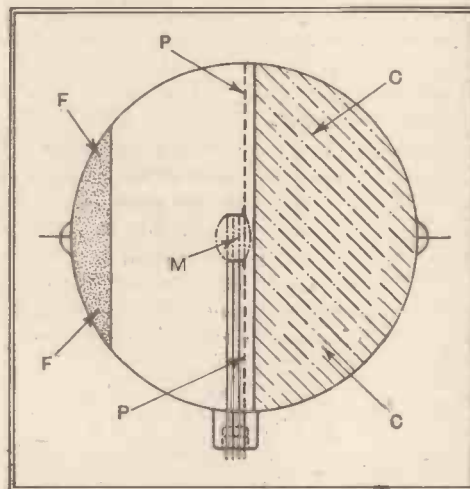

The principle of regeneration applied to a photo-electric cell in conjunction with an electron multiplier.

further possibilities. Another promising scheme is to apply the principle of reaction to "boost" the output from a photo-electric cell. For instance, the electrons liberated by the impact of light upon a photo-sensitive cathode can be focused upon a fluorescent screen, and the light from the latter "fed back" on to the sensitive cathode, where it serves to increase the strength of the original stream.

The accompanying drawing (from Patent 499661) shows a "back-coupled" photo-electric cell of this kind used in combination with an electron-multiplier, the latter serving to emphasise the regenerative effect. The cell contains a photo-electric cathode C which is arranged opposite to a fluorescent screen F, an electron-multiplier M being placed midway between the two and in line with a transparent screening partition P. Light falling on the cathode C liberates primary electrons, which are attracted by the positive

voltage on the first electrode of the multiplier M and pass from it through a series of "permeable" target-electrodes, each biased more positively than the last.

The emerging stream, now considerably amplified by secondary emission, produces a more intense light than usual on the fluorescent screen F. This light "reacts" back on the sensitive cathode C to liberate more electrons, and so build up the current strength still further until it is taken off from the last or output electrode of the multiplier M. To prevent the current from building-up to saturation a "quenching" frequency is applied to the screen electrode P, together with an EMF of carrier frequency.

PROBLEM CORNER-22

An extract from Henry Farrad's correspondence, published to give readers an opportunity of testing their own powers of deduction:—

"Radiovilla,"
Hackbridge.

Dear Mr. Farrad,

Thank you for the tip about the dynatron oscillator; it is working very nicely now with a tapped battery. Meanwhile, here is another little perplexity that I have come across in working on the 56 Mc/s amateur band. For adjusting the tuning of a certain circuit over a small band in the region of this frequency it was inconvenient to have the very small variable condenser close up against the coil; I hadn't got a small enough condenser anyway. But I knew that when a certain capacity is tapped across part of a coil it is equivalent to a smaller capacity across the whole coil. I did this, using a condenser with a capacity of 0.000025 mfd. I reckoned this would be equivalent to about 5 micro-microfarads across the whole coil. But the funny thing is that when this condenser is connected, instead of the frequency going down, as it ought, it goes up!

The leads are nearly 6 inches long, unfortunately; but I have spaced them well apart—about 3 inches actually. Can you tell me why the condenser acts apparently as a negative capacity? And another thing—although the whole of this tuning arrangement is thoroughly "low loss," it makes it very difficult for the circuit to oscillate at all.

Yours sincerely,
Ray Lea.

Henry Farrad's solution is given on p. 514.

The Wireless Engineer

IN the June issue of our sister journal, *The Wireless Engineer*, which is on sale to-day, June 1st, price 2s. 6d., is the first part of an article which investigates the static and dynamic characteristics of pentode and tetrode output valves with a view to minimising in their design the distortion in the output stage of a receiver. Another article in the same issue gives some theoretical and experimental considerations of the requirements governing the production of power when using triode oscillators for ultra-short wavelengths.

A monthly feature of *The Wireless Engineer* is the Abstracts and References section, compiled by the Radio Research Board, in which is given abstracts of articles on wireless and allied subjects published in the World's technical press.

Winding Short-wave Coils

POINTS IN DESIGN AND CONSTRUCTION

FEW amateurs wind their own medium- and long-wave coils nowadays; with ganged circuits and the modern construction of coils the ability of the amateur to wind them himself is somewhat limited. With short-wave coils a different position arises as, even on the lower frequencies, coils consist of only a few turns of wire, and, although matching is still necessary, the coils can be cheaply and simply constructed at home.

Let us consider a short-wave resonant circuit as shown in Fig. 1 (a). This consists of a coil or inductance L and a condenser C. Actually, the circuit is not quite as simple as this, since the wire which forms the inductance L has a resistance R_L , and since a perfect condenser is never obtainable, except perhaps of the quartz-insulated type, the condenser has a certain resistance R_C . Also, the coil has a self-capacity C_0 which resonates with the coil inductance L at the natural frequency of the coil itself. Thus the circuit becomes as Fig. 1 (b). Normally, the natural frequency of the coil is much higher than the operating frequency range of the complete LC circuit and so C_0 , which normally consists of 3 to 5 mmfds. capacity, can be combined with C and forgotten except when the total minimum capacity in parallel with the inductance is considered.

The step-up or "goodness factor" of a coil or condenser is known as its Q value, which is always greater than unity. The

Q value of a coil is equal to $\frac{\omega L}{r}$ or $\frac{1}{\omega C r}$ for

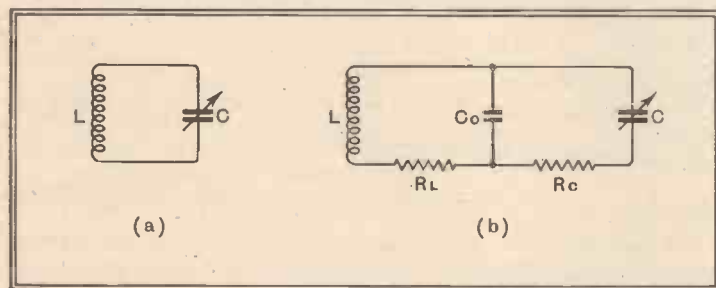

Fig. 1.—An oscillatory circuit and its equivalent in practice.

a condenser. When a condenser of Q_C is placed in parallel with an inductance of value Q_L , the effective total Q, that is Q_T , is equal to the inverse of the sum of the reciprocal values, or:—

$$Q_T = \frac{1}{\frac{1}{Q_C} + \frac{1}{Q_L}}$$

However, provided condensers of good insulation are used, with a minimum of insulating material, the factor R_C in Fig. 1 (b) may be neglected and considered as part of R_L , since it is very small with ceramic type condensers or air-dielectric condensers with ceramic insulation, at any

By

DAVID R. PARSONS, Grad.I.E.E.

rate at frequencies below 15 Mc/s. Thus, provided high quality condensers are used, we can say that the efficiency of a short-wave tuned circuit depends largely on having a "high Q" coil.

High Q coils are necessary in oscillators for efficiency and stability, and in RF amplifiers they are absolutely essential for gain and selectivity. Highly technical papers have appeared on the subject of coil design but very little advice has appeared in a form suitable for general readers. Thus, the following notes on short-wave coil design may be found very useful.

Provided reasonable care is taken in the selection of a former, no difference is noted between the Q of an air coil and a similar one wound on a smooth former, i.e., one with no grooves.

If grooves are required for mechanical reasons, ribbed formers should be used or the grooves should be of a depth not exceeding $\frac{1}{3}$ to $\frac{1}{2}$ the diameter of the wire. On no account should deeply grooved formers be used.

If shallow grooved formers are used, the Q reduction with bakelite is about 10 to 15 per cent., reaching nearly 30 per cent. with cardboard or wood.

The diameter of coils should be as great as possible, and the ratio $\frac{l}{D}$ (length/diameter) should preferably be less than unity, a ratio between 0.5 and unity being usually

the best. Naturally, the length will be governed by the inductance required, but with large-diameter wire such as 16 or 18 SWG, the Q is practically independent of winding length.

Wire diameter should be as great as possible, though gauges below 16 SWG are not normally used, chiefly because of winding difficulties. Gauges between 16 to 22 SWG are generally preferred.

The spacing between turns may be equal to the diameter of the wire. Actually a small increase in Q is noticeable when the spacing is 25 per cent. greater than the wire diameter, but there is little practical

advantage in exceeding this figure.

Bare copper wire is best, but after a time oxidation occurs and, due to skin effect, the RF resistance of the coil increases considerably. Consequently, enamel wire is preferable in all cases as the surface cleanliness of the wire is maintained and the enamel has negligible effect on the Q of the coil.

With stranded wire, the losses in insulation become considerable, and thus the advantage of stranding the wire is lost. Iron-cored coils are also not advisable on short waves, since the reduction in copper made possible by their use is naturally small, and the iron loss is high.

If a coil has a diameter D, then any coil can be placed over it should have a diameter at least equal to 2D. With such a screen, its Q will be reduced by about 5 to 10

per cent., while its inductance reduction will be 10 to 15 per cent. The latter can, of course, be allowed for when the coil is originally designed.

The ends of the coil should be at least a coil diameter away from the ends of the screen.

When coils are not screened but placed near a metal chassis as shown in Fig. 2, the dimension d should be at least equal to the diameter D of the coil. As d is decreased, the Q falls slowly at first and is not halved until d is about 1/10th of D, although the inductance change will be considerable.

Suppose, for example, we required to wind a short-wave coil having an inductance of 1 microhenry and a $\frac{1}{2}$ -inch diameter paxolin former is available. 20 SWG is probably the smallest gauge an amateur can handle unless a small winding mandril is available. 20-gauge enamelled wire has a diameter of 0.038 inch.

For maximum Q, spacing between turns

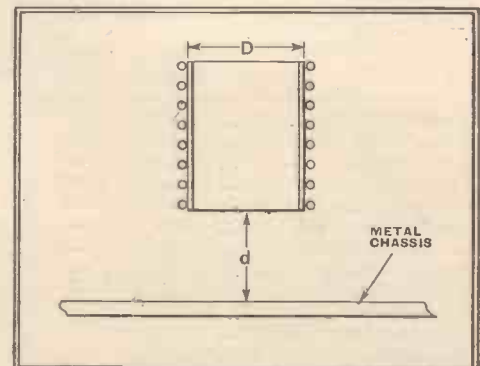

Fig. 2.—Spacing between coil and screen should be at least equal to coil diameter.

THIS article contains much useful information on such important factors in coil design as ratio between length and diameter, choice of former, wire gauge and covering and the effect of screening

Winding Short-wave Coils—

is equal to $1.25 d$, where d is the diameter of the wire used. Therefore spacing should be $\frac{0.038 \times 5}{4}$, or 0.0475in. The turns per inch will be $\frac{1.000}{0.0475}$, or 21.1. The effective

diameter D of the coil is equal to the coil former diameter plus diameter of wire, or 0.500in. + 0.038in.; that is, 0.538in.

Using the *Wireless World* Abac No. 19 for coils of 0.2 to 20 microhenrys, we have $\frac{l}{D}$ ratios of 0.88, a satisfactory value, and the total turns will be $21.1 \times 0.538 \times 0.88$, or 10 (approximately).

Since the spacing is 0.0475in. we can use another length of wire as a dummy winding for spacing purposes; 20 SWG is 0.046 inch diameter, so a length of this wire may be wound alongside the actual coil wire and removed afterwards.

The smallest screening can in which the above coil should be mounted would have a diameter of 1in. and the ends of the coil should be at least 1 inch away from any steel chassis. Such a screen will reduce the inductance to about 0.85 to 0.9 microhenry, but if we had known a 1-inch screening can was to be used we could have based our calculation on a value of 1.15 μ H and the final inductance would be approximately 1 μ H.

form, for their electrical properties are identical with, or very similar to, other valve types.

Some of the Loctal valves have 0.15A filaments. The variety is sufficient to permit their exclusive use in a midget receiver with series-connected heaters and no transformer. The smaller current and the higher voltage drops in the heaters of the rectifier and output valves of this series make it unnecessary to drop voltage in a resistance external to the receiver. Thus the usual flexible cord resistor can be dispensed with. This resistor may not have caused any fires, but it certainly looks dangerous and has never been approved by the insurance underwriters who are the final authorities in America on the safety of household electrical appliances.

In addition to the Loctal valves a new series of valves has appeared with the subscript GT. These are merely glass valves in a straight-sided tubular form. There are thus the following electrical equivalents: 6K7 (metal), 6K7G (glass), 6K7GT (tubular glass), and the near equivalents 6SK7 (single-ended metal) and 7A7 (single-ended glass Loctal).

American Loctal Valves

CHARACTERISTICS AND DIMENSIONS

THE "Loctal" valves recently introduced by Hygrade-Sylvania and Philco have a new base—of the octal variety—which differs from the ordinary octal base. Although the pins will fit present octal sockets, the pin connections are different, and although the centre locating pin has the usual key to ensure correct insertion, it is grooved near the tip to engage a spring catch or lock in its own special type of socket. The current-carrying base-pins are set in the thickened glass base of the valve and supported entirely by it. The metal shell, of which the locating peg is a portion, has clearance holes through which the contact pins pass. The glass shells of the Loctal type are rather small, and to agree with the present tendency all Loctals are single-ended.

Could we but undo the past here in America, we should certainly have fewer valves with octal bases, and certainly not two sorts of octal base. Perhaps then we should not so soon have come to the end of our alleged system of valve designations, which appears to have been abandoned in the Loctal series. Previously an initial "6" has meant "operating filament voltage between 6 and 7," but in the Loctal series such valves have type designations beginning with a "7" instead of a "6," presumably because the system is at best

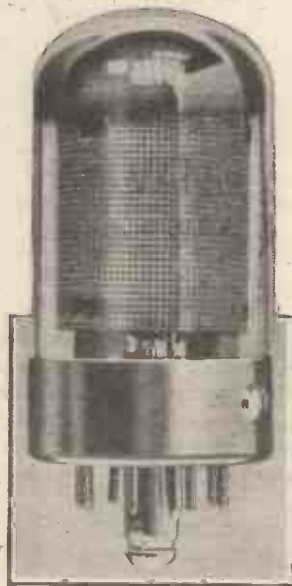

This view of the 7A7 clearly shows the locking groove on the centre pin.

vague, and the "6" combinations are so nearly used up that we are encountering such type numbers as "6AC5-G," "6J7-GT." The old system of arbitrary numbering was no worse.

The Loctal valves, however, are good. Their advantage lies in a desirable physical

The Elements of Radio Communication.

By O. F. Brown, M.A., B.Sc., and E. L. Gardiner, B.Sc. 2nd edition. Pp. 551+vii. Published by Oxford University Press, Amen House, Warwick Square, London, E.C.4. Price 16s.

THIS book is an elementary text-book and it opens with an introductory and historical chapter. High-frequency alternating currents are then dealt with, after which oscillations and radiation are treated.

Valves are discussed in some detail, and such modern forms of electronic apparatus as the electron multiplier, the gas-triode, and the cathode-ray tube are included. Chapters on transmission, detection and amplification follow, and there are long chapters dealing with receiving circuits and selectivity. Propagation and directional reception are not omitted, and the book concludes with a chapter on television.

Although formulae are occasionally introduced, the book is largely non-mathematical. The operation of wireless apparatus is well explained and the book is unusually free from errors. The authors intend it to cover the syllabus of the City and Guilds Grade 1 examination, and to assist the student have provided a set of examination questions at the end of each chapter. Answers are not provided, however. W. T. C.

CHARACTERISTICS OF THE LOCTAL VALVES.

Type No. Valve.	1231 R.F. Pentode	7A6 Duo-diode	7A7 R.F. Pentode	7A8 Octode	7B5 Output Pentode	7B6 Duo-diode-triode	7B7 R.F. Pentode	7B8 Heptode	7C5 Output Tetrode	7C6 Duo-diode-triode	7Y4 Rectifier	35A5 Output Tetrode	35Z3 Rectifier
Heater volts	6.3	6.3	6.3	6.3	6.3	6.3	6.3	6.3	6.3	6.3	6.3	35.0	32.0
Heater amps.	0.45	0.15	0.3	0.15	0.4	0.3	0.15	0.3	0.45	0.15	0.5	0.15	0.15
Anode volts...	300	—	250	250	250	250	250	250	250	250	350	110	250
Screen volts	150	—	100	100	250	—	100	100	250	—	—	110	—
Grid bias	—	—	-3	—	-18	-2	-3	—	-12.5	0	—	-7.6	—
Anode current (mA)	10.0	—	8.6	3.0	32.0	1.0	8.5	3.5	45.0	1.3	60.0	35	100.0
Screen current (mA)	2.5	—	2.0	2.8	5.5	—	2.0	2.7	4.5	—	—	2.8	—
Mutual conductance (mA/V)	5.5	—	2.0	0.6	2.2	1.1	1.7	0.55	4.1	1.0	—	5.5	—
AC resistance (Ω)	700,000	—	800,000	—	—	90,000	700,000	—	—	100,000	—	—	—
Input capacity ($\mu\mu$ F)	8.5	—	6.0	7.5	—	3.0	5.0	10.7	—	2.4	—	—	—
Output capacity ($\mu\mu$ F)	6.5	—	7.0	9.0	—	3.0	7.0	7.5	—	3.0	—	—	—
Grid-anode capacity ($\mu\mu$ F)	0.015	—	0.005	0.15	—	1.5	0.005	0.15	—	1.4	—	—	—
Load resistance (Ω)	—	—	—	—	7,600	—	—	—	5,000	—	—	2,500	—
Power output (watts)	—	—	—	—	3.4	—	—	—	4.25	—	—	1.4	—

Cathode-ray Oscilloscope

SIMPLE UNITS EMPLOYING A 2½ in. TUBE

(Concluded from page 486 of last week's issue)

IN many applications of the CR tube a linear time-base is needed, but as it is not always required it is included in a separate unit from the tube. When using the units together they are connected by plugs and sockets, as shown in the drawings. In most cases X₁, Y₁, and E on the tube unit will be joined, and X₂, Y₂, and E joined respectively to SW, VA, and E on the time-base unit, while the signal to be examined is applied between V and E. If the amplifier is not required Y₂ and VA are disconnected and the signal applied between Y₂ and E; in general, it will be necessary to insert a condenser in series with the lead to Y₂ in order to prevent any steady potential in the signal circuit from giving a steady deflection.

When first setting up the gear, set the gain control R₅ at minimum and the amplitude and frequency controls R₁₁ and R₁₃ about half-way. In the tube unit, set R₅ for maximum bias, that is, for minimum brilliance. Switch on and allow time for the valves to warm up. Then advance the brilliance control. If all is in order a horizontal line should appear, and the focus control can then be adjusted for maximum sharpness. No greater brilliance than is necessary should be used.

Adjust the amplitude until the line extends nearly across the tube. Apply a signal, and with the sync control at minimum turn up the gain control until the

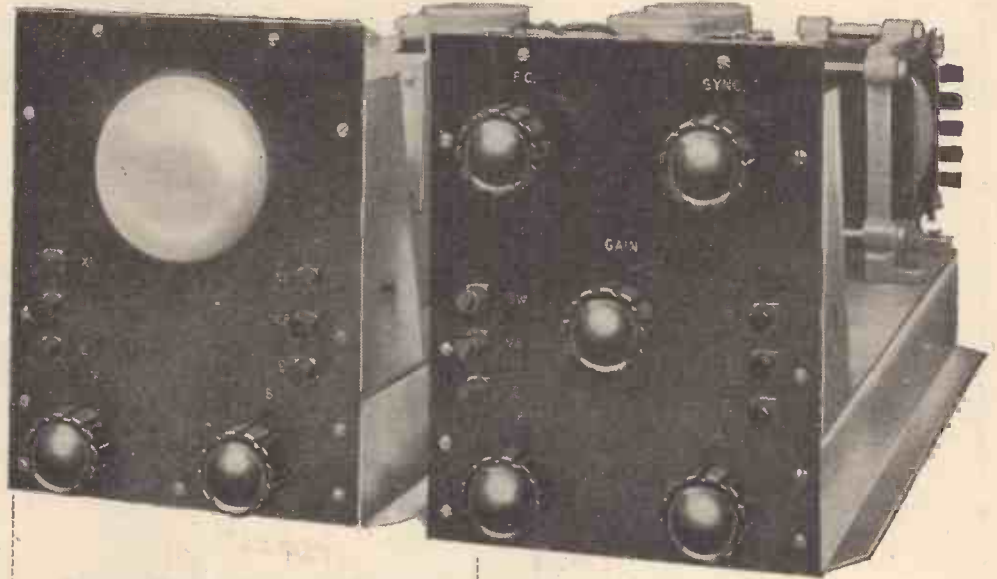

IN concluding the description of this cathode-ray oscilloscope notes on the construction are given as well as an account of the method of operation with the time-base.

is nearly steady. These are when the time-base and signal frequencies bear definite relationships to one another. With the usual sine-wave input, there will be one setting giving a half-sine curve for the pattern, another giving one sine curve, another giving two, and so on.

It is usually best to pick the setting which gives three complete sine curves, because one is then certain of obtaining an undistorted picture of the centre one. The two end ones may be slightly curtailed by the fly-back.

Having obtained as steady a picture as

distortion of the ends of the trace may occur.

Little need be said about the construction of the apparatus, for the drawings are self-explanatory. It must be pointed out, however, that the CR tube is very susceptible to the stray field of the mains transformer. The optimum position for the transformer specified is shown on the drawings, but if a component of different design is employed a new position for it may have to be determined experimentally.

Constructional Hints

The components should be completely assembled on the base-plates before wiring is started. The earthing points are particularly important, and it is necessary to see that the metal is bright, so that the screws are not held back by cellulose paint. See that the heads of the screws on all valve holders are well recessed and, if sparking across to the base is feared, cut out and insert waxed paper or bakelite rings between the valve holders and chassis. Avoid subjecting the heavy transformer leads to excessive twisting, and do not pull on the finer wires, since they may break off short at the bobbin. Before fitting the valve holders it is advisable to solder the blades to their screws rather than rely entirely upon the tightness of the nuts; a really hot iron is needed for this purpose.

Make sure of the identity of the centre-taps on the transformer HT windings. An error in this respect will lead to the destruction of an electrolytic condenser immediately the unit is switched on. Avoid nicking the wire when cutting back sleeving—it is better to slide the sleeving off when cutting to length. Use 22 SWG tinned wire for connecting up and 1 mm. (size of hole) silk sleeving. It is, of course, easier to wire from the circuit

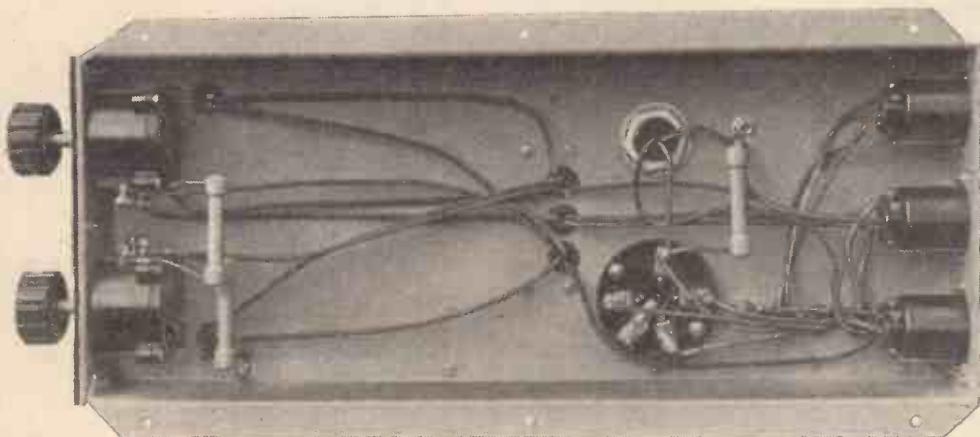

An underview of the tube unit showing the wiring.

pattern on the tube reaches a convenient height. The pattern will be complex and unsteady. Now turn the frequency control *slowly*. The pattern will change and certain settings will be found at which it

possible, advance the sync control while readjusting the frequency slightly. The picture should lock in and be quite steady. The sync control should be advanced no more than is necessary, otherwise some

THE PRACTICAL WIRING DIAGRAMS

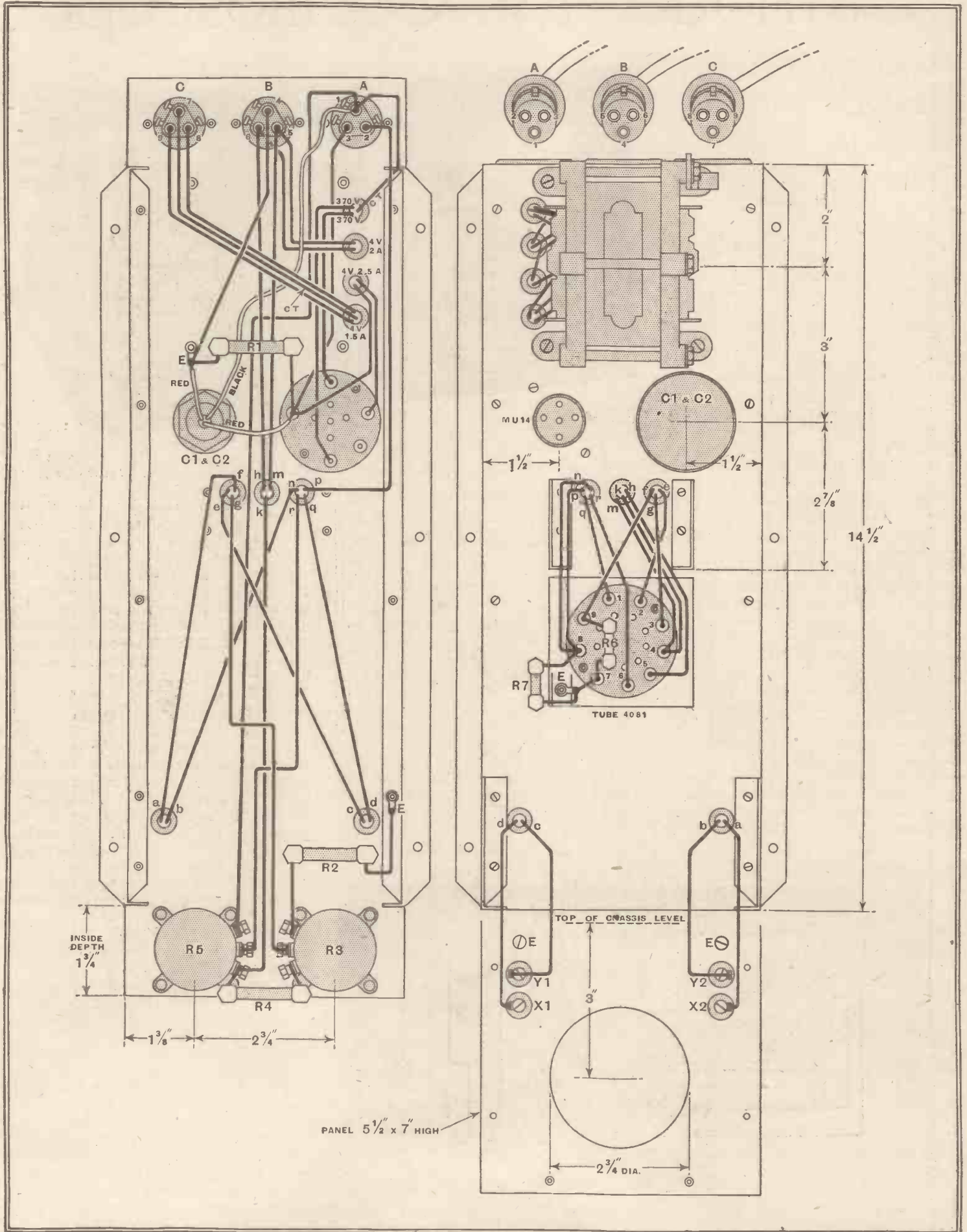

This diagram gives full details of the oscilloscope unit.

THE OSCILLOSCOPE AND TIME-BASE UNITS

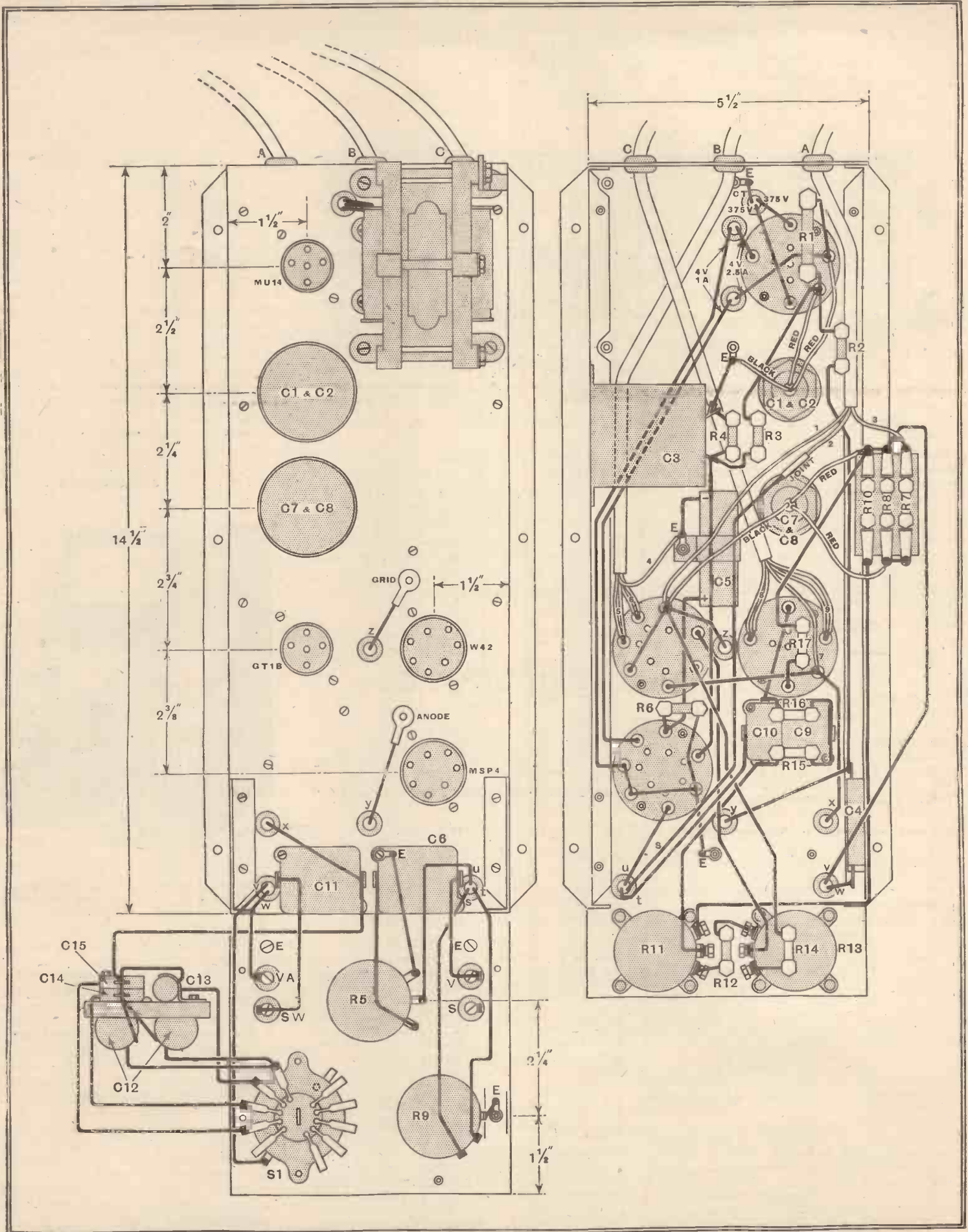

The wiring of the time-base and amplifier unit is clearly shown in these drawings.

Cathode-ray Oscilloscope—

diagram than from the practical detail drawings, but the latter may prove additionally helpful.

The precise details for putting together the bank of switched condensers can be gleaned from the drawing. Assemble and wire this piece before fitting it to the front plate. Only two leads come from it, V,

round with the screws slackened off. Identification marks are required on the three cross-connecting plugs and sockets at the rear of the units. Use the soldering tags on the mains transformers for the mains connections so as to prevent whiskers of wire from shorting across the terminals.

When first putting the gear into opera-

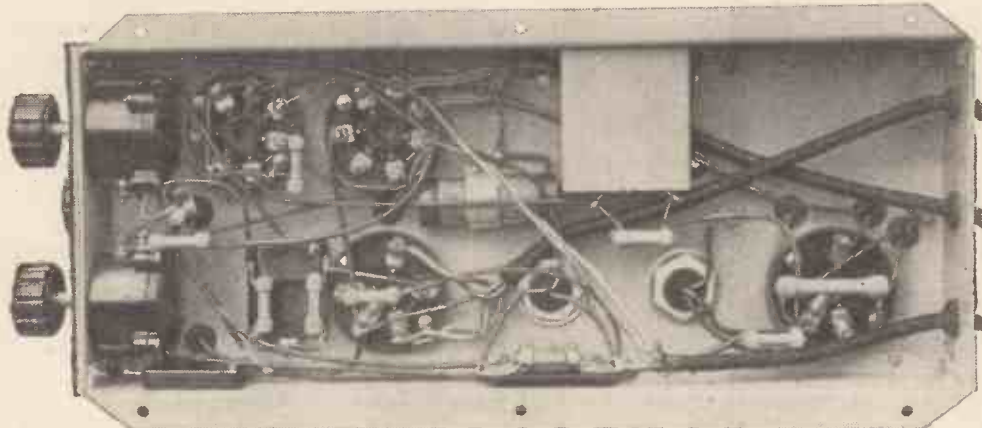

In this view of the time-base and amplifier unit the under-base components are clearly shown.

the centre point of the switch, and X, the common junction of the condensers.

As the CR tube cannot be mounted with a great degree of accuracy in its socket, allowance has been made to permit some small amount of rotation of the holder. It is therefore necessary to allow slackness in the leads to the holder. In addition, the tube may be centred by slightly bending the brackets or by skewing them

tion, earth-connect both sets of X and Y plates and then, by advancing the brilliance control from zero in a clockwise direction, a stationary spot will be obtainable in the centre of the screen. Keep the brilliance down when only the spot is produced or the screen will be permanently marked. Only as a result of careless operation will blemishes be found on the screen.

Television Programmes

Sound 41.5 Mc/s.

Vision 45 Mc/s.

An hour's special film transmission intended for demonstration purposes will be given from 11 a.m. to 12 noon each weekday. The National or Regional programme will be radiated on 41.5 Mc/s from approximately 7.45 to 9 p.m. daily.

THURSDAY, JUNE 1st.

3, 247th edition of Picture Page. 3.20-4, O.B. from Coombe Hill Golf Club, Surrey, showing part of the match between Reg Whitcombe and Bobby Locke. The programme will include a golf demonstration by Archie Compston.

9, Ray Ventura et ses Collégiens. 9.35, Gaumont-British News. 9.45-10.15, 248th edition of Picture Page.

FRIDAY, JUNE 2nd.

3, Cabaret Cruise No. 9. 3.45, Cartoon Film. 3.50, Gaumont-British News.

9-10.30, "The Anatomist," by James Bridie, introducing again Knox, Burke and Hare, and the West Port murders.

SATURDAY, JUNE 3rd.

2.55-4, O.B. from Hyde Park. The Royal Review of the London Fire Brigade and London Auxiliary Fire Service.

9, Scenes from the "Dorchester Floor Show." 9.30, Gaumont-British News. 9.40, Tennis Demonstration by Dan Maskell. 9.55, Cartoon Film. 10-10.30, "If I were a Millionaire." A scientist, an Irish poet, a woman novelist, a sculptor, and a taxi driver come to the studio to tell how they would spend a million pounds.

SUNDAY, JUNE 4th.

3, Cartoon Film. 3.10, Friends from the Zoo

presented by David Seth-Smith. 3.25, "Zoo to You," featuring Mabel Constanduros—Film. 3.35, Third edition of "Fantastic Garden."

8.50, News. 9.5-10.35, "Good Morning Bill," a play by P. G. Wodehouse.

MONDAY, JUNE 5th.

3-4.30, "The Anatomist" (as on Friday at 9 p.m.).

9, Jack Jackson and his Band. 9.30, Gaumont-British News. 9.40, A. G. Street presents another Guest Night. 10.10, Cartoon Film. 10.15-10.25, Catherine Clark, pianoforte.

TUESDAY, JUNE 6th.

2.55-4, Theatrical Garden Party; O.B. from the Ranelagh Club, Barnes. Jasmine Bligh and F. H. Grisewood will introduce viewers to leading personalities of stage and screen.

9, Friends from the Zoo. 9.15, Cartoon Film. 9.20, British Movietone News. 9.30-10.30, "The Parnell Commission," a reconstruction of the famous forgery investigation of 1888-1889, written and produced by Denis Johnson.

WEDNESDAY, JUNE 7th.

3-4.30, "The Insect Play," by Karel Capek.

9, "Rough Island Story," No. 2—The Hon. Harold Nicolson and J. F. Horrabin continue their collaboration and bring the history of the British Isles up to 1500. Illustrations by Pearl Binder. 9.25, Cartoon Film. 9.30, Charles Heslop in "Moonlight 'n' Everything," with Patricia Burke, Edward Cooper and Patricia Leonard. 10.5, Gaumont-British News. 10.15-10.30, Foundations of Cookery By Marcel Boulestin.

The Rider "VoltOhmyst"

A SENSITIVE METER EMPLOYING
A PUSH-PULL VALVE
VOLTMETER CIRCUIT

THE outstanding feature of this instrument, which measures DC resistance and voltage, is its high input resistance. Up to 500 volts the input resistance is 16 megohms, and for the three ranges between 500 and 5,000 volts it is 160 megohms. It will be appreciated that the meter can be connected to AVC and other automatic control circuits while a receiver is in operation without affecting performance or introducing any appreciable error in the voltage reading. It may also be used for checking oscillator performance as the input is taken through a shielded probe incorporating a resistance adjacent to the tip which reduces the effective input capacity of the instrument to approximately 1 micro-mfd.

The basic circuit is a push-pull valve voltmeter using pentode valves, in which grid current and the contact potential effect in the valves are reduced by the use of a common cathode resistance of high value. In addition, a measure of inverse feedback is employed. The readings of the meter, which is connected in a bridge circuit, of which the valve anode circuits form two



The Rider "VoltOhmyst" may be used for the measurement of all receiver voltages including AVC without introducing any appreciable load on the circuit.

arms, are independent of small fluctuations in the supply voltage.

Voltages from 0.05 to 5,000 may be read in nine overlapping ranges and resistance from 0.1 ohm to 1,000 megohms in seven stages. The meter reads in the same direction for both volts and resistance and no external battery is required for the higher resistance values. Actually the potential across the resistance during measurement is only 0.03 volt across 0.1 ohm and 3 volts across 1,000 megohms.

A reversing switch enables either positive or negative potentials to be measured with the instrument earthed and without the necessity of changing leads.

A special model suitable for operation from 230-volt AC mains is obtainable in this country through Holiday and Hemmendinger, Ltd., 74-78, Hardman Street, Manchester, 3. The price is 20 guineas.

Transmitter Measurements

USING A HOME-MADE DIODE VOLTMETER

An amateur transmitter sooner or later feels that DC measuring instruments alone are inadequate for experimental work. Whilst such devices as neon tubes, lamps, etc., are useful, RF meters are essential to obtain maximum efficiency from a transmitter. Current meters of the cheap hot-wire or more expensive thermo-couple types are available, but potential-measuring instruments are not so readily obtainable.

The input impedance of such instruments should be as nearly as possible purely resistive to avoid upsetting circuit conditions, and as high as possible since the power output of amateur apparatus is usually comparatively small. These conditions limit the choice to a valve voltmeter or a cathode-ray oscilloscope.

It was with these points in mind that the diode peak-voltmeter shown in the photograph was built, and it has the advantage that with the exception of the milliammeter the parts can be found in the junk box of the average experimenter. Such instruments have been used for years by professional radio engineers for work on high-power transmitters.

As can be seen from the circuit diagram in Fig. 1, a diode is used to rectify the applied potential, and for a portion of the half-cycle, when the anode of the diode is positive with respect to its cathode, current flows, thus charging the feed condenser. During the remainder of the cycle the charge on the condenser leaks away through the 1-megohm resistance. If suitable circuit values are chosen the voltage across the feed condenser will not fall appreciably during the portion of the cycle when it is not receiving a charging current.

Thus the DC voltage across this condenser will be very nearly equal to the maximum or peak voltage of the applied potential. If a sensitive milliammeter is connected in series with the resistance the two together form a DC voltmeter and measure the potential across the condenser.

The whole is, in fact, very similar to a power supply using a valve rectifier with a condenser input filter; the output voltage is very nearly equal to the peak value of the AC voltage from the transformer so long as the load is light. Information on the factors governing the choice of the values of capacity and resistance can be

THE valve voltmeter described in this article will be found a valuable adjunct to the equipment of an amateur transmitting station. It can be used for neutralising PA stages, measuring power output, correctly terminating feeders, and as a field strength measuring set, to mention a few of its many uses.

By

D. P. TAYLOR

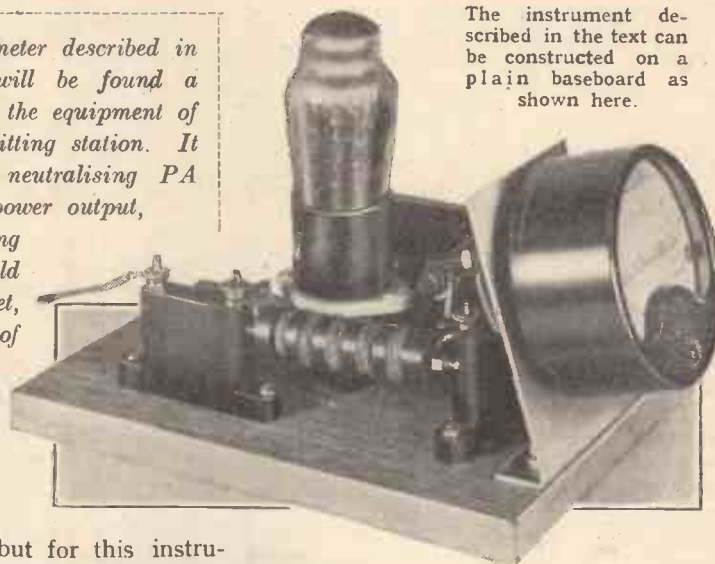

The instrument described in the text can be constructed on a plain baseboard as shown here.

obtained elsewhere,¹ but for this instrument a resistance of 1 megohm and capacities of 0.0001 mfd. and 0.0005 mfd. prove very satisfactory at frequencies of 7 Mc/s and higher.

An RF choke is connected in the anode circuit of the diode to prevent the filter condenser appearing across the voltmeter terminals as a large input capacity. Any choke having a high impedance over the frequency range used is satisfactory in this position. The feed condenser also isolates the diode from DC in the circuit to be measured.

A 0.0-0.5 mA meter is connected in series with the resistance; thus the voltmeter has a full scale range of 500 peak volts, and as the meter scale is sub-divided into 50 divisions each division corresponds to 10 peak volts.

The valve used in the actual instrument is a 2.0-volt medium-impedance battery triode with the anode and grid connected together to form the diode anode. During the first experiments with the instrument this valve proved so satisfactory that it was retained permanently, but there

is no reason why a normal diode should not be used if desired.

It was also found during experiments that a reduction in filament voltage from 2.0 to 1.5 volts had no appreciable effect upon the calibration, so that a single dry cell can be used for filament supply.

¹ "Voltage Measurement at Very High Frequencies," E. C. S. Megaw, B.Sc., D.I.C., *The Wireless Engineer*, February, 1936.

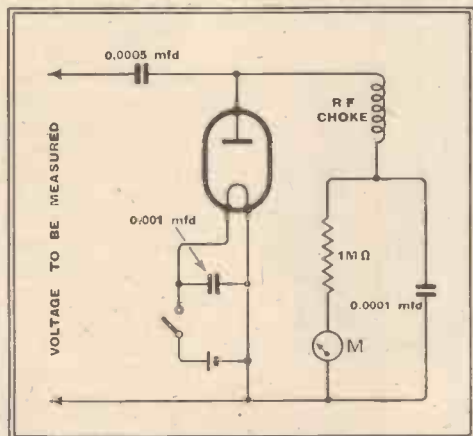

Fig. 1.—Circuit diagram of the diode peak voltmeter.

When the voltmeter was first built it was noticed that the temperature of the valve filament was increased by induced RF when making high-voltage measurements. In the interest of valve life a condenser was connected directly across the filament pins to eliminate this effect.

No particular care is necessary in the construction of the unit, but good components of low leakage are necessary and the wiring should be arranged to reduce stray capacity to a minimum. If access can be had to a megger or ohmmeter the one-megohm resistance should be chosen so that its value is a few per cent. on the low side rather than the reverse, as this will tend to correct for the low reading error normal to the meter. The voltmeter should not be regarded as a precision instrument, but on comparison with a slide-back valve voltmeter it was found that for voltages over 100 the error did not exceed about 6 per cent., the reading always being low.

The input impedance of the instrument is approximately equal to a 100,000-ohm resistance shunted by a few micro-microfarads of capacity.

When using the meter it should be placed as close as possible to the apparatus under test so that the connecting lead may be kept as short as possible, and the lead connected to the filament side of the diode joined to the earthy side of the circuit being tested.

It should be remembered that the calibration is in terms of peak volts, which must be multiplied by 0.707 to give RMS values, assuming a sine waveform.

Applications of the Peak-voltmeter

The writer is constantly finding new uses for the meter, but a few of the more obvious ones are given for the guidance of readers.

Transmitter Measurements—

For neutralising a transmitter, the voltmeter is connected across a portion of the anode inductance and the transmitter switched on with the HT supply to this stage disconnected. When the anode circuit is tuned to resonance a reading will be obtained on the meter (unless the amplifier is already perfectly neutralised).

This reading should be reduced to zero or a minimum value by adjustment of the neutralising condenser, retuning the anode circuit after each adjustment. In this way an amplifier can be neutralised considerably more accurately than by the usual neon tube or flash-lamp bulb methods.

When an untuned feeder is correctly terminated there should be no standing wave along its length. It is easy to detect standing waves by connecting the voltmeter across the feeder wires at several points less than one-quarter wavelength apart.

If all the voltages so measured are not substantially the same the feeder is incorrectly terminated, and adjustment should be made at the end remote from the transmitter.

Some idea of the power carried by a correctly terminated feeder can be obtained by:

$$\text{Power} = \frac{V_{\text{RMS}}^2}{Z} \text{ or } \frac{V_{\text{PEAK}}^2}{2Z}$$

where Z is the characteristic impedance of the feeder.

For example, a peak voltage of 110 volts across a 600-ohm feeder would indicate a power of about 10 watts.

If the voltmeter is connected across a parallel tuned circuit (such as an absorption wave-meter) and a small vertical aerial connected to the diode anode end of the coil, a rough field-strength measuring device results.

This should be taken away from the transmitter to some point in the open near the aerial, adjustments can then be made to the transmitter

and aerial to obtain maximum reading. If the absorption-wave-meter is tuned to a harmonic frequency the presence of harmonics can be detected and steps taken to eliminate them.

In practice the reading obtained with this device is small, but if made more sensitive by the addition of a triode DC amplifier it can be used to determine horizontal aerial directivity patterns.

The simplest method of measuring transmitter power output is to load up the transmitter by a resistance whose impedance value does not change appreciably with

frequency, the voltage across this is then measured. A carbon rod resistor is suitable for this purpose and its resistance can be determined by means of an ohmmeter; if the value is substituted in the place of Z in the formula the power output can be calculated.

Power Output

Power output can also be tackled from another angle: A class "B" or "C" amplifier can be regarded as a generator which is effective over alternate half-cycles, the flywheel effect of the tank circuit being sufficient to carry over during the period when the valve is inoperative. From ordinary electrical engineering theory the power output when working into a pure resistance load (a tank circuit tuned to resonance can be regarded as a pure resistance) is given by:

$$\text{Power output} = \frac{V_{\text{RMS}} I_{\text{RMS}}}{2} = \frac{V_{\text{PEAK}} I_{\text{PEAK}}}{\sqrt{2} \sqrt{2}} \cdot \frac{1}{2} = \frac{V_{\text{PEAK}} I_{\text{PEAK}}}{4}$$

Where V and I are the RF anode voltage and current respectively.

There is a relationship between the RF anode circuit of a valve and the DC anode current I_{dc} as shown by the anode circuit milliammeter. In the case of a class "B" where the grid is biased to anode current cut-off in the undriven condition this relationship is:

$$I_{\text{PEAK}} = \pi I_{dc}$$

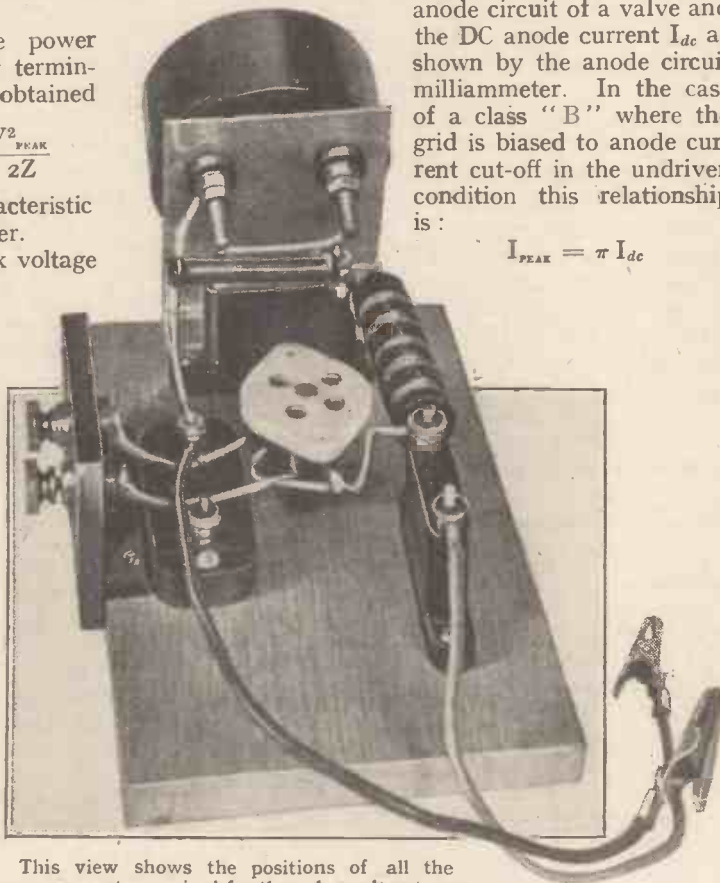

This view shows the positions of all the components required for the valve voltmeter; note the method of mounting the valveholder.

This can be substituted in the original expression giving:

$$\text{Power output} = \frac{V_{\text{PEAK}} \pi I_{dc}}{4} = 0.78 V_{\text{PEAK}} I_{dc}$$

In this expression there are two variables, viz., I_{dc} and V_{PEAK} , the former is read directly from the anode current meter and the latter by connecting the diode peak-voltmeter between the anode of the valve and earth. In this way the power output of a stage can be determined.

In the case of a class "C" amplifier where the valve passes anode current over

$1/3$ of the cycle the relationship between I_{PEAK} and I_{dc} is changed and the power output formula becomes:

$$\text{Power output} = 0.9 V_{\text{PEAK}} I_{dc}$$

It should be remembered that I_{dc} is in amperes and not in milliamperes. If the aerial coupling is varied and readings of I_{dc} and V_{PEAK} taken for each adjustment, the product of these two can be plotted against the degree of coupling and the setting for maximum power output determined.

The choice of the correct value of "Q" for the output tuned circuit of a transmitter is a matter of some importance particularly when telephony is used. To determine "Q" an RF ammeter should be included in series with the tuning condenser to measure circulating current, and the peak-voltmeter connected across the whole of the tuning inductance. The amplifier is loaded up by the aerial in the normal manner and the two meter readings noted, "Q" then being equal to 0.707 times the product of the meter readings divided by the power output. For example, if the peak-voltmeter reading is 200 volts and the ammeter 1.0 ampere, the power output being 10 watts, then:

$$Q = \frac{0.707 \times 200 \times 1}{10} = 0.707 \times 20 = 14 \text{ approx.}$$

HENRY FARRAD'S SOLUTION

(See page 506)

THE inductance of a rectangular loop 6 inches by 3 is about $0.42 \mu\text{H}$, which has a reactance at 56 Mc/s of 150 ohms. The $25\text{-}\mu\text{F}$ condenser has a reactance at the same frequency of -110 ohms. So actually the condenser with its leads is effectively an inductance, having a reactance of $150-110$, or 40 ohms, and which, therefore, is about $0.1 \mu\text{H}$. The effect of shunting an inductance across the whole or part of a tuned coil is to reduce the total effective inductance (inductances, like resistances, are reduced when in parallel), and hence the frequency is increased.

If the leads *must* be long, it is better for them to be close together, for not only is the inductance thereby reduced, but also the radiation resistance, which is responsible for the increased loss. If *very* close, of course, the capacity is excessive; there is a certain best spacing for any set of circumstances. But at best the arrangement is not likely to be very satisfactory, and every effort should be made to shorten the leads.

The Wireless Industry

TAYLOR ELECTRICAL INSTRUMENTS, LTD., 45, Fouberts Place, London, W.1, have prepared advance specification sheets of their Model 70 and Model 75 multi-range meters which are to be released at the end of this month.

Philips Lamps, Ltd., are now installed in their new eight-storey premises at Century House, Shaftesbury Avenue, London, W.C.2. The telephone number, Gerrard 7777 remains unchanged.

Dry batteries suitable for American portable sets additional to those mentioned under this heading, have been introduced by "Drydex." They are the Type 1158, $1\frac{1}{2}$ volt, $2\frac{1}{2} \times 2\frac{1}{2} \times 4$ inches at 2s. 6d. and Type 1159, 45 volts, $4\frac{1}{4} \times 2\frac{1}{2} \times 5\frac{1}{2}$ inches at 3s. 9d. Both are fitted with sockets for 2-pin plugs.

NEWS OF THE WEEK

BROADCASTING IN CANADA

The C.B.C. and Their Majesties' Visit

WITH the visit of Their Majesties to the Dominion of Canada the broadcasting organisation of the Country has come into prominence. Such an Empire link-up as that organised by the Canadian Broadcasting Corporation for May 24th, which culminated in the message of the King, speaks volumes for the efficiency of the organisation.

At present the Dominion network consists of ten stations operated by the C.B.C., and twenty-seven privately owned stations which are affiliated with the C.B.C. In addition to these there are approximately fifty privately owned stations, none of which have a power greater than 10 kW. No new privately owned station will be permitted to use more than 1 kW. With such a vast country, network broadcasts necessitate the hire of many thousands of miles of telephone line, and it is noteworthy that roughly 20 per cent. of the Corporation's revenue is expended on line rental charges.

High-power Chain

The Corporation's plan is to have a chain of high-power stations across Canada which would cover the whole country.

So far the C.B.C. has four 50-kW stations—CBF (Montreal), CBL (Toronto), CBA (Sackville, N.B.), and CBK (Saskatoon, Saskatchewan). There are also CBR (Vancouver, B.C.) 5-kW and five low-power transmitters in Ontario and Quebec.

Although at present not represented in the short-wave field, the C.B.C. is seeking permission and assistance from the Federal authorities to establish a short-wave service.

Major W. E. Gladstone Murray, who has been general manager of the C.B.C. for nearly three years, in an article in a *Daily Telegraph* supplement devoted to the Dominion, says that in a country like Canada vast distances and differences in language and time zones, of which there are five, make a regional development logical and indeed inevitable.

He also states that a scheme discussed by representatives of the B.B.C. Empire Service and the C.B.C. plans for the B.B.C. to broadcast each week two or three specially prepared programmes for Canada in order to strengthen the broadcasting tie between the United Kingdom and the Dominion.

START POINT AND CLEVEDON

Anti-fading Mast-Radiators

WHEN the new B.B.C. 100-kW, 285.7-metre station at Start Point is opened by the Duke of Somerset on the 14th of this month it is hoped that effective broadcast coverage will be extended over most of Devon, Somerset, Wiltshire, Dorset, and parts of Hampshire, as well as the coast of Sussex.

The B.B.C. engineers are hopeful that the new aerial system will function according to a somewhat ambitious plan. The two 450ft. mast-radiators employed are 350ft. apart, one of them being excited directly, and the other through a phase-shifting network. Designed for anti-fading, they are each divided at a height of some 310ft. from ground by a compression insulator bridged by a suitable impedance. The anti-fading effect is obtained by adjusting this impedance.

It would be a mistake to suggest that this method will abolish fading entirely. It is expected, however, that it will have the effect of greatly extending the distance at which fading is first noticeable.

Opening on the same day will be the little sister station at Clevedon, Somerset, on a wavelength of 203.5 metres, which is now used by Bournemouth and Plymouth. Using a power of 20 kW, Clevedon will fill in the gaps not covered by Start Point, including Bristol and parts of North Somerset and Devon.

AMATEURS

Problems Facing Britain and America

THROUGH their national association, the American Radio Relay League, 51,000 amateur radio operators have requested the Federal Communications Commission of the U.S.A. to permit them to use "duplex," or simultaneous two-way transmissions at all times on amateur frequencies above 112 Mc/s.

On his return from a conference with commission officials in Washington, Mr. K. B. Warner, managing secretary of the League, reported that the proposal was being considered favourably.

British amateurs are permitted to work under the same rules for "duplex" as for "simplex" (one way) transmissions. They may transmit for ten-minute periods during any four hours of the day, but each period of transmission must be followed by a minimum of three minutes' listening.

Invasion of the Amateur Band

On September 1st of this year the wavelength allocations arranged at Cairo come into effect. European broadcasting stations may invade a portion of the amateur 40-metre band. American amateurs are taking steps to protect their present frequency allotments, and in addition to forming a committee of the Board of Directors to work out its problems the A.R.R.L. has secured an admission from the Federal Communications Commission that they would not look with disfavour upon an attempt by the amateurs to blanket reception in the U.S. of foreign broadcasts on amateur frequencies.

The G.P.O. in London is con-

sidering the position of the British amateur, and a statement regarding his position after the wavelength change will be announced by the Post Office before that change is brought into effect.

OLYMPIC GAMES

Further Broadcasting Arrangements

THE Finnish Government recently granted eight million marks to the broadcasting organisation, Suomen Yleisradio, for the solving of some of the technical problems which the engineers have to face in arranging the broadcasts for next year's Olympic Games at Helsinki.

Finland has but two telephone cables for foreign communication—one via Stockholm and one via Tallinn, Estonia. The latter contains three conductors, of which two will be available for broadcast relays, and the Stockholm cable has thirty-two conductors, of which eight will be at the disposal of the broadcasting organisation. As it is estimated that at least twenty-five simultaneous commentaries will have to be radiated each day, it has been necessary to resort to recording on a large scale. An order has therefore been placed for forty A.E.G. Magnetophon iron-powder film recorders.

It has also been decided to provide a fleet of seven vans, several of which will be equipped for handling two different recordings at once.

A site at Kovisto, near Bjorneborg, has been chosen for the new 100-kW short-wave transmitter which is to radiate world-wide transmissions on the Games. The station is to be provided with Marconi equipment.

GUARANTEED SERVICE

IN order to combat the menace of the unqualified self-styled "expert" service man, the Danish service organisation, Radioteknisk Forening, has taken drastic steps to protect the public and the interests of its members. The association has launched a guarantee system, according to which the organisation as a body vouches for the work of individual members.

An adhesive "control" label, to be affixed to any set handled by members, will be the customer's guarantee that the work done is beyond reproach and that the charge is just.

"YARDSTICK" FOR RECEPTION

A SPECIAL set, built to incorporate all that is best and representative in modern receiver design, is now being used by the Approval Subcommittee of the Central Council for School Broadcasting as a "yardstick" to test the many

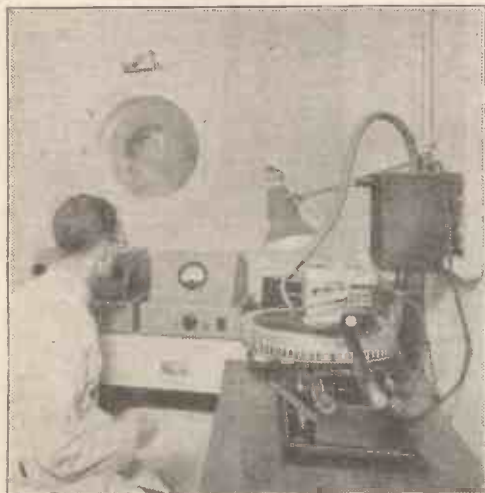

THE RECORDING ROOM of the new personal recording studio in the recently opened H.M.V. showrooms in Oxford Street. The engineer is watching the db-calibrated volume indicator. Direct play-back cellulose acetate blanks are used and a vacuum suction pipe to remove the threads of swarf during cutting is fitted. The double-glass window looks on to the studio where an artiste is seen at the microphone.

News of the Week—

makes submitted for recommendation for school use.

The Committee's examination of all apparatus takes the form of an exhaustive listening test carried out in a room which approximates acoustically to a school classroom of about 600 sq. ft. The "jury" consists of representatives of the Council, technical experts, and teachers.

B.B.C. ADVISES FOREIGN LISTENERS

"CHOOSE Droitwich in the daytime, but stick to the medium-wave Nationals at night." This is the gist of a letter which Sir Stephen Tallents, B.B.C. Controller of Public Relations, has sent to a number of correspondents from Central Europe. Many letters have reached Broadcasting House from German and other listeners, who are picking up the foreign news bulletins but wish for even better reception.

Listeners beyond 400 miles away are strongly urged to try for the short waves. Interference by neighbouring stations using high power seems to be one of the big bugbears to Continental listeners striving to hear the B.B.C. news bulletins. Says Sir Stephen: "We hope that measures now in hand to increase the power of our London, North, Stagshaw and Welsh Regional transmitters will improve matters, but listeners should recognise that an increase in power is seldom just a question of turning on a tap."

BIG-SCREEN TELEVISION

FOLLOWING the successful projection of the Derby by the new Baird big-screen receiver at the New Victoria Cinema, London, Mr. J. L. Baird told a *Wireless World* representative that he is making rapid progress with colour television in England and America. He hinted at a personal visit to New York some time in August, but emphasised his reluctance to leave his work in England for any prolonged period.

A cable from America states that Mr. J. M. Schenck, chairman of 20th Century-Fox films, has announced that his company is prepared to take an active interest in television through its interest in Gaumont-British and Baird.



THE BAIRD BIG SCREEN TELEVISION RECEIVER at the New Victoria Cinema is permanently installed in the front of the auditorium. This picture was taken during the Derby transmission.

DEUTSCHLANDSENDER**New High-Power Transmitter**

ALTHOUGH announced as being "under construction" as long ago as early 1934, the new Deutschlandsender 150-kW transmitter has only just been opened and taken over by the German Minister of Posts. Situated at Herzberg, fifty-six miles south of Berlin, it is in what is sentimentally called the heart of Greater Germany.

The mast-radiator, which is over 1,000ft. high, is surmounted by an 80ft. capacity ring. It is announced that further masts will be added to the aerial system to overcome fading and that the power will be considerably increased by the time the Montreaux plan comes into force next Spring.

Even in the building of this transmitter, the demands of the Four-Year Plan, which limits the amount of foreign metal to be used, have been met.

**FROM ALL
QUARTERS****The Royal Return**

WE understand that arrangements are practically complete for broadcasting commentaries on the return of the King and Queen to this country on or about June 24th. As we go to press the port of arrival is still uncertain, but the B.B.C. is arranging for a team of commentators to "cover" the event from the moment Their Majesties land until they reach Buckingham Palace. It is hoped also to televise the arrival at the London terminus and possibly outside Buckingham Palace.

Czech Broadcasting

THE administrative organisation of the Reich Protector in Prague has founded a department of broadcasting attached to the Office for Cultural-Political Affairs. The new section is in charge of a former member of the Ministry of Propaganda in Berlin. His duties will involve the supervision and preparation of Czech programmes broadcast from Brno, Prague and Moravska-Ostrava (the 1.5-kW transmitter). He will also control the transmission of the German programmes from Melnik and Brno.

French O.B. Unit

A TELEVISION mobile unit is being constructed in France on the lines of the B.B.C. O.B. units. It is expected to be put into service during the autumn.

Broadcast Television Lessons

A PRACTICAL television course is being broadcast by Dr. Belcher on Tuesdays at 2 a.m., B.S.T., from W1XAL on 6.04 and 11.73 Mc/s. A recorded version is transmitted for Europe every Friday at 10 p.m., B.S.T., on 25.45 and 19.83 metres. Particulars of the course, which will continue until mid-July, may be obtained by writing to station W1XAL, University Club, Boston, Mass., U.S.A.

HOUSE FLAG for Cable and Wireless, which was unfurled at every branch of the Company throughout the world on Empire Day. The flag, which comprises a red St. George Cross superposed on a golden cross on a dark blue ground, incorporates the letters C & W. and a golden crown.

**Swedish Commercial Station**

THE Swedish Government has allocated the sum of 1,775,000 kroner (approximately £38,800) for the construction of a new transmitting and receiving centre designed to serve shipping and air transport which will be erected on a site at Vallda-Onsala, near Gothenburg. The present commercial stations at Kungsbacka and Nya Varvet will be replaced by the new centre, although retained as stand-by equipment.

"Believe It or Not"

A C.B.S. broadcast from 800ft. below ground in the Carlsbad Caverns, New Mexico, by Bob Ripley, of "Believe It or Not" fame, presents unique difficulties. There is only one telephone line into the town of Carlsbad and as that will be needed for the broadcast, owners of telephones in the town have agreed to forego using their 'phones during the half-hour programme on June 2nd. This also means that Ripley will not be able to receive his cue into the programme; he will have to rely on the accuracy of his watch.

**Welter-weight Championship by
Scophony**

GOOD reception of the Armstrong-Roderick fight last Thursday was obtained on the Scophony receiver installed at the Odeon Cinema, Leicester Square. The picture, which was of similar dimensions to that of a cinema screen, could clearly be seen from all parts of the house. The brilliancy was adequate and the synchronising held well. Back projection was used, and the picture was of reasonably good black and white colour.

Lithuanian Peoples' Set

IN order to increase the comparatively low radio density of Lithuania, the Government has decided to subsidise the production of a cheap standard receiver on the lines of the German Volksempfänger. In addition, public accumulator charging stations are being erected all over the country for the benefit of listeners who use battery receivers.

The Industry

AT last week's Radio Industry Luncheon at the Connaught Rooms, the speaker was Mr. S. J. de Lotbinière, B.B.C. Director of Outside Broadcasts, who explained some of the difficulties of O.B. work. At the end of the luncheon members saw the Derby on television receivers.

Remote Control

THE two cars used in the demonstration crash at Cowley were steered electrically by trailing cables, and not by wireless as previously reported.

Morse Code: Revised Version

THE older generation of wireless men may find it hard to believe that the morse code, with which they have been familiar all their lives, has now been changed. Indeed, several correspondents have suggested that our recently issued booklet, "Learning Morse," is incorrect with regard to the "comma" and "full stop" symbols. The doubters can rest assured that the code as given in the booklet has been revised in accordance with decisions made at the Cairo Conference.

Physics in Industry

THE growing importance of physical science in almost every branch of modern industry is reflected in a 15 per cent. increase in the membership of the Institute of Physics. The annual report of the Institute shows that at the end of 1938 the membership stood at 1,169 as compared with 753 as recently as 1934. The president of the Institute is Dr. C. C. Paterson, and the hon. secretary is Prof. J. A. Crowther, of the University of Reading.

I.E.E. Awards

THE Council of the I.E.E. has made awards of premiums in the Wireless Section for papers read or published during the session 1938 to the following:—L. W. Hayes and B. N. MacLarty (Duddell Premium), Dr. J. D. McGee and Dr. H. G. Lubszynski, Dr. R. L. Smith-Rose and Dr. H. G. Hopkins, P. R. Coursey and S. N. Ray.

Aerial Masts

PRACTICAL HINTS ON DESIGN AND CONSTRUCTION

Concluded from page 482 of last week's issue

By R. H. WALLACE

FIFTY feet probably represents the average span of the usual type of receiving aerial, and the dimensions of steel masts of various heights have been worked out for this length of aerial, these details being summarised in Table III. The shorter masts are in two sections, and those over 36ft. in three, this being necessary as the tubes are not generally available in longer lengths. If tubes over 18ft. can be obtained, Table II (see last week's issue) will indicate by how much they may be increased. It is suggested that the concrete base, if used, should be nine inches square at the top, tapering to fifteen at the bottom. It will be best to cast it on to the pole before erection, as there is then no difficulty in supporting the tube in the vertical position. A mould may be made in cheap wood, and this may be stripped after three or four days, though the erection should not be attempted till a week has elapsed so that the cement may be fully hard.

With regard to the cost of these masts, it is not possible to give actual prices per foot, as local conditions vary a good deal. Most ironmongers should be able to quote prices and undertake to supply, but it is evident that those that live near a large town or industrial neighbourhood will pay less, and probably be able to obtain the tubes directly from stock. The cost goes up heavily with increasing diameter, and it can be taken that the unsupported steel pole will, for the tube alone, probably be at least twice as dear as a normally guyed

type. The tube will not last long unless it is properly protected from the weather, and should be painted every five years, while the galvanised mast should receive this treatment after not more than ten. The part within the concrete may be regarded as safe so long as the latter is intact, but the actual junction of the two is especially liable to attack, and should be

painted each year. The foundation should, of course, entirely enclose the bottom end of the tube, and should project some inches above the soil.

Even taking into account the superior life of the steel tube, it is not likely that it will be economically a better proposition, unless the con-

structor has special facilities for obtaining the parts, or the supply of wooden poles is inadequate; this applies more particularly to the unsupported type. For most people the wooden pole is not only the cheaper but is equally suitable, and, given the proper treatment before erection, may be relied on for a life of from ten to twenty years. This is especially the case if the lower end, which is the most likely to rot, is set in concrete.

For the present purpose the wooden pole has the advantage that it is tapered and there is no need to use different diameters; also, that there is no need for jointing, easily the most troublesome part of the steel construction. Since the taper is fixed, the design resolves itself largely

THE author has previously discussed the erection of tubular steel masts, and here summarises the data necessary for the design of masts of various heights. The erection of wooden masts is dealt with, and hints are given on short masts of the type that are attached to the chimney or wall of the house.

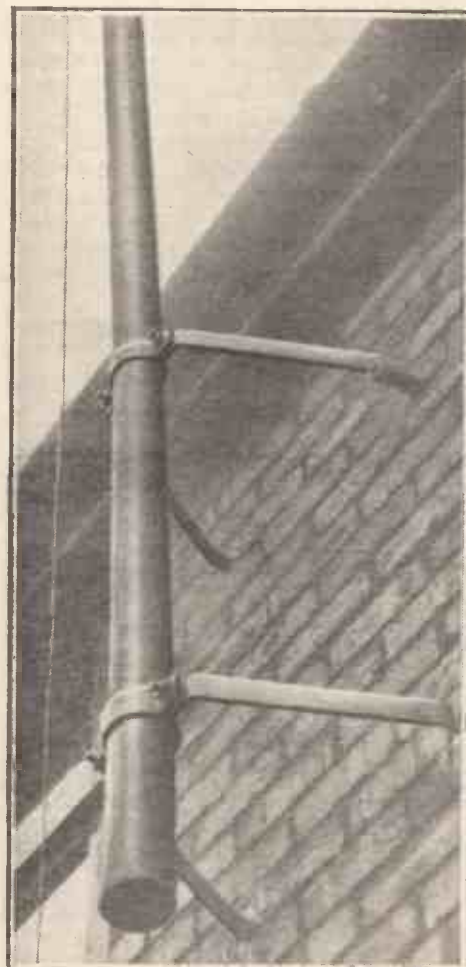

Brackets for fixing pole to brickwork. The ends are "fishtailed" to give a better hold in the mortar.

into choosing the necessary top diameter to withstand the various stresses, the bending action of the guys and wire, or the combined action of the wind and wire pull, if of the unsupported type. The stresses imposed by the action of the stays are greatly increased if their point of attachment is not the same as that of the aerial, and so attention should be paid to this point. For poles of 35ft. and over it is advisable to use another set of guys from the centre of the mast; these may be taken to the same plate in the ground as the others. If this is not done, the compressive action due to staying may cause undue bending in the middle of the pole.

The factor of safety allowed for wood needs to be larger than for steel, as the former is less homogeneous. However, this is offset to some extent by the fact that the wooden pole is solid, and will stand much greater flexure than the steel one without any permanent bending. As with steel, the cost of the longer masts will be greater per foot than in the case of short ones, and will depend upon local circumstances. It will generally be the case that the wooden pole will work out to less than

TABLE III
Dimensions of Steel Masts, for 50ft. of 7/22 Copper at 2% sag.

Type	Height over ground	Total length, ft.	Top Section		Middle Section		Lower Section	
			Length, ft.	Size and quality	Length, ft.	Size and quality	Length, ft.	Size and quality
"A"	25	30	12½	1½" Steam.	—	—	18	2" Steam.
"A"	36	42	12½	1½" Steam.	12½	2" Steam.	18	2½" Steam.
"B"	30	35	17½	1" Steam.	—	—	18	1½" Steam.
"B"	35	40	18	1" Steam.	13	1½" Steam.	10	2" Steam.
"B"	40	46	18	1" Steam.	13	1½" Steam.	16	2" Steam.
"C"	30	35	17½	1" Gas.	—	—	18	1½" Gas.
"C"	35	40	18	1" Gas.	13	1½" Gas.	10	2" Gas.
"C"	40	46	18	1" Gas.	13	1½" Gas.	16	2" Gas.

"A" Unsupported with lapped joints and concrete base.

"B" Guyed, narrow base, with lapped joints and concrete base.

"C" Guyed, normal base, with lapped or screwed joints and guys to each joint.

Aerial Masts—

half the cost of the corresponding stayed steel one.

Since the unsupported wooden pole will have to be of greater diameter at the top than that necessary for a guyed one, its cost per foot will be greater; in fact, the buyer will have to pay for the piece at the top which has had to be cut off, and may thus lose as much as fifteen feet of good timber before the needed size is attained. This extra cost is to a certain extent offset by the saving in guys and fittings, but, in spite of this, the unsupported type will generally be appreciably dearer, though its neatness is worth the difference to many people. The life of a wooden pole is greatly dependent on the precautions taken before erection. The practice, common with many for garden timber, of sterilising by charring in a fire, cannot be readily applied to a long pole, and, in any case, might well lead to a reduction in strength.

The best method is to apply hot creosote or one of the excellent wood preservatives now on the market, giving two coats at least. It is an additional advantage to stand the butt in the tin of preservative after this for a few days, as the germicide will then soak up into the grain at the part where most protection is needed. Before these remedies are applied, the bark must be removed and the wood seasoned for some time.

The taper of natural-grown timber will vary from 0.1in. to 0.15in. per foot run; an average value will be 0.13in., and this is the basis for Table IV, which gives the approximate thickness needed for different conditions. The top diameter is the most important, the others being given more as

a guide to the sizes to be expected at the other points. The remarks made concerning steel masts are applicable equally to wooden ones as regards staying and foundations. The unsupported wooden pole will not remain upright in soft soils, and it will be necessary to fit the kicking blocks already mentioned or to use a concrete base, the latter being the better practice, especially in waterlogged ground. The kicking blocks should be about 3ft. by 4in. by 2in., and should be treated as the pole with preservative. One should be fitted on the wire side of the mast just below ground level, and the other at the butt on the opposite side; these will prevent the slow movement of the pole due to the pull of the wire, which is always in the same direction, while the wind pressures will in time balance out, and are not likely to cause permanent deflection.

The top of a wooden mast should always be protected from the rain by a sheet of

copper or zinc fixed by means of brass screws, as shown in the sketch, otherwise water will run down the grain and rot set in. Some care ought to be taken, too, with the attachment of the guys; if these are simply taken several times round the pole and then twisted

A wooden mast, stayed by 7/20 SWG steel wire, should, if not affixed on a concrete base, be secured with kicking blocks as shown. In the drawing the base of the mast has been turned round at an angle of 90 degrees relative to the top section in order to show the kicking blocks more clearly.

back, a sheet of thin metal underneath will distribute the pressure and prevent cutting of the wood. The neatest way, however, is to obtain a ring of metal which will fit the top of the mast, and fix the necessary hooks in this; the taper of the pole will prevent this slipping any farther down and the aerial pulley may be fixed at the same

TABLE IV.

Dimensions of Wooden Masts for 50ft. of 7/22 Copper at 2% sag.

Type	Height over ground	Total length ft.	Diameter at top, in.	Diameter at ground, in.	Diameter at butt, in.
"A"	30	35	2½	6½	7½
"A"	35	40	3	7½	8
"A"	40	46	3	8½	8½
"B"	30	35	2	6	6½
"B"	35	40	2	6½	7½
"B"	40	46	2	7½	8
"C"	30	35	1½	5½	6
"C"	35	40	1½	6	7
"C"	40	46	1½	6½	7½

- "A" Unsupported, with concrete base or kicking blocks.
- "B" Guyed, narrow base, with concrete base or kicking blocks.
- "C" Guyed, normal base, with guys to plates and guyed in middle over 30ft

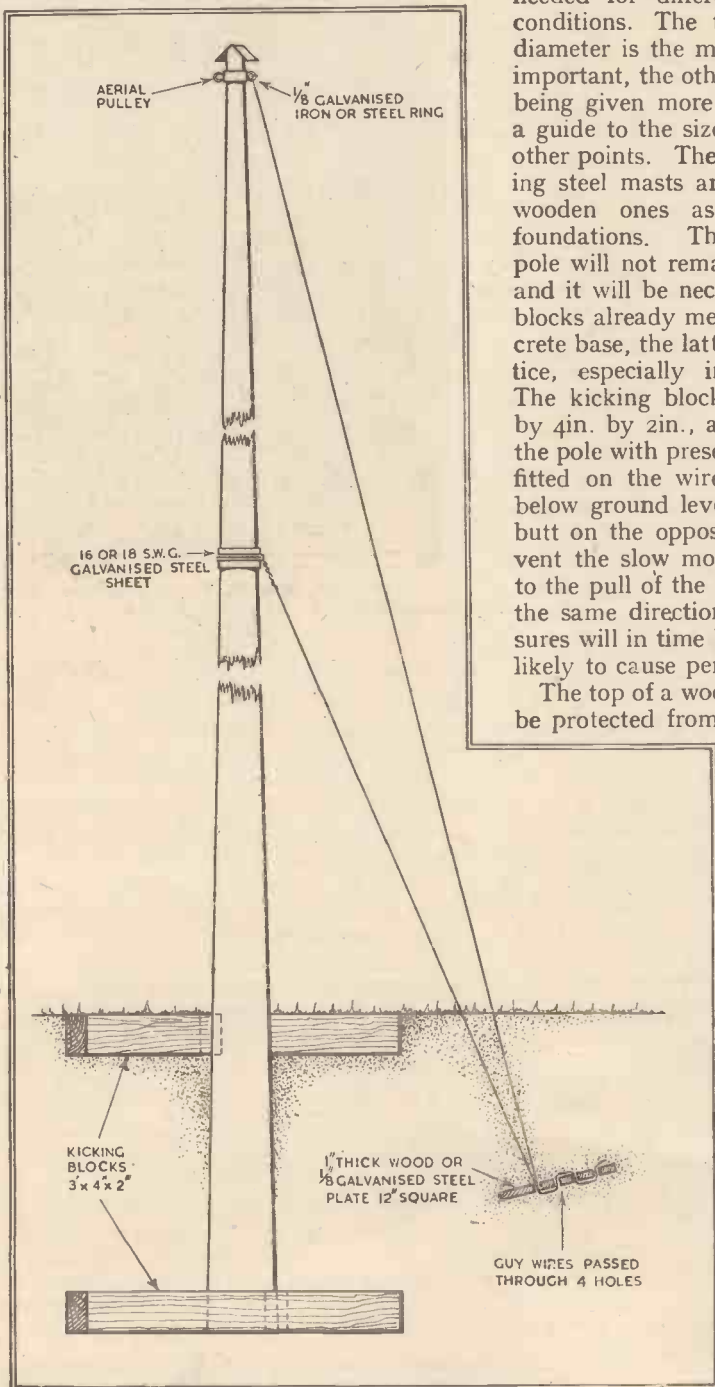

point. Such trifling precautions as these may seem to some to be hardly worth bothering about, but are, in fact, the most needed of all, as wood nearly always fails from rot, and, as long as this can be kept at bay, will have an almost indefinite life.

Some notes on the erection of the heavier masts may not be out of place here, as this can be a very difficult business unless tackled in the correct manner. The best way is to dig the hole so that all its sides but one are vertical, or nearly so, the other side being sloped towards the direction from which the pole is to be raised. This being done and the required depth reached, the mast is set so that the butt is over the hole and the pole is reared up; as this is done, the lower end falls naturally into the right place and there is little danger of the mast slipping sideways, while, when upright, it can be held against the straight side until the earth is filled in. In this way two persons can safely erect quite tall poles with the minimum of effort. It goes almost without saying that the earth should be well rammed with a heavy block so as to consolidate it after filling in. In fixing the unsupported type it will be advisable to tie temporary guys or struts to hold the pole vertical while this operation is performed.

Moulding the Base

The mixing of concrete is not difficult as long as a few simple points are followed. The cement should be fresh and the sand well washed and free from dust. It is an advantage to include some granite chippings if available. The best proportions are not critical, one part by weight of cement to three of sand and five of gravel will do nicely, or, if gravel is not available, one of cement to five of sand. The whole should be well mixed in the dry state before the water is added, and the amount of this should be the minimum with which the mixing is satisfactory; on

Aerial Masts—

no account should any of the ingredients be frozen or at a very low temperature. When the mould is filled, the mortar should be well tamped with a rod at intervals. A good deal of the final strength will be developed in the first three days,



Method of anchoring the lead-in wire in order to prevent swinging, and to remove strain from the terminal of the lead-in insulator.

it is advisable to fit a pulley at the house end of the aerial; certainly those who have once ascended to the roof in bad weather to replace a broken wire will not attempt again to do without such a fitment. The rope that is a necessary link between the aerial proper and the wall should have a diameter of not less than $\frac{1}{4}$ in., and it is preferable to buy it tarred; this reduces the strength a little when new, but makes it much less susceptible to the weather. Where poles of large size are to be fitted to the wall, special brackets are needed; one such is illustrated. Brackets or clips built into brickwork should be at least four courses below the top of the wall, or the bricks above may lift. A cement and sand

mortar will be found suitable for fixing. The swaying of the lead-in during windy weather may give rise to some fading unless it is anchored in some way before the lead-in tube is reached; this is easily done with one or two of the stand-off insulators that are procurable. At the same time, the terminal is relieved of the strain due to the aerial. The detailing of the above precautions may bring a smile to the faces of some of the old school of amateurs who started their listening when tall masts and good aerials were necessary to get any results at all. There are, however, many who have only recently taken an interest in these matters, and it is to these that this article is addressed.

In Next Week's Issue

Five-metre Portable Transmitter

THREE-VALVE CRYSTAL-CONTROLLED SET

THIS transmitter has been designed primarily for portable use and derives its power from a six-volt accumulator. It is economical to operate and as the HT consumption is less than 70 mA either a vibrator HT unit or a small rotary converter, or dry batteries can be used. As it is intended to be employed for CW transmissions as well as for telephony good frequency stability is essential and this is achieved by employing a 7 Mc/s crystal-controlled oscillator. Though the working frequency is within the 58.5 to 60 Mc/s amateur band there are only three valves.



LIST OF PARTS

- 1 Twin Midget condenser, 30 m-mfd. each section JB
- 1 Twin Midget Special condenser (double speed vanes) JB
- 1 40-m-mfd., condenser Premier Tro, 40T
- 1 15-m-mfd., condenser Premier Tro, 15T
- 2 0.01 mfd., mica condensers T.C.C. Type "M"
- 9 0.002 mfd., mica condensers T.C.C. "M"
- 1 25-m-mfd., ceramic condenser T.C.C.
- 1 150,000 ohms, 1 watt resistance Erie
- 2 100,000 ohms, 2 watts resistances Erie
- 1 30,000 ohms, 2 watts resistance Erie
- 1 25,000 ohms, 2 watts resistance Erie
- 1 5,000 ohms, 2 watts resistance Erie
- 1 350 ohms, 2 watts resistance Erie
- 1 250 ohms, 2 watts resistance Erie
- 2 5 ohms, 1 watt resistances Erie
- 1 Piezo-electric Quartz Crystal frequency between 7,310 and 7,495 kc/s Q.C.C. "U"
- 5 Closed circuit jacks Bulgin J6
- 1 Ultra-short-wave choke Eddystone 1011
- 1 RF choke, 1.35 mH, 18 ohms resistance Premier
- 1 50 m-mfd., air dielectric trimmer Polar C801
- 11 Midget Frequentite insulators Eddystone 1019
- 2 2½-in. insulators Eddystone 1028
- 2 Octal valve holders Clix X218
- 1 Frequentite 5-pin valve holder Eddystone 1074
- 2 4-way connector blocks Bryce 5C2
- 4 Miniature Direct drives Eddystone 1099
- 2 Top cap valve connectors Belling Lee
- 4 Shaft couplings, ¼ in. bore Bulgin
- Miscellaneous: Peto-Scott
- 1 Aluminium screen, 4½ × 5½ in.
- 1 Plywood chassis, 12 × 6 × 1½ in.
- 1 Plywood chassis, 12 × 4½ × 1½ in.
- 1 Wooden panel, 16 × 13 × ¼ in.
- 2 Panel side supports, 12 × 6 in.
- 2 Small insulated brackets, centre 1½ in. above base.
- 2 Small aluminium brackets, centre 1½ in. above base.
- 5 Pieces Paxolin, 1½ × 1½ × ½ in. for mounting jacks; 12 in. Paxoline rod ¼ in. diameter for condenser couplings.
- Quantity No. 20 SWG, and No. 15 SWG enamelled copper wire.
- 2 Paxolin formers:
 - (1) ¾ in. diameter × 1½ in. long.
 - (2) 1 in. diameter × 1½ in. long.
- Quantity No. 16 SWG and No. 18 SWG turned copper wire, sleeving, ½ in. and ¼ in. round head No. 4 screws.
- 12 in., ½ in. outside dia. copper tube for P.A. tank coil.
- Valves:
 - 2 6V6G valves Tungram
 - 1 TVO3-10 valve Mullard

and after a week it may be considered ready to take the full stress, though the strength will continue to increase for months.

The house end of the aerial will be fitted to the most handy place, but sometimes this will be unduly low, and if it is not desired to sacrifice the benefits of a good mast in this way resort may be had to the use of a short pole at this end. This will naturally be of wood in the majority of cases. An easy way to mount such a pole is to use some of the different types of pipe clips; one of those shown in the photograph published last week is suitable for screwing to woodwork. There are other kinds of clip for building into brickwork, and it should be noted that these are all sold by nominal sizes, that is, the nominal size of the tube they fit; a 1½ in. pipe clip will thus fit a pole of nearly 2 in. diameter. The sizes of the various standard tubes were given in Table II. The strength of such short poles may be reduced somewhat below that of the longer masts, and a top diameter of 2 in. would be enough for a 15 ft. pole supporting 60 ft. of 7/22 wire.

Where the chimney is high enough an upper support consisting of a simple hook such as that illustrated will be strong enough. It is hardly necessary to say that

UNBIASED

Music Unmasked

I APPARENTLY touched several of the medicine men and witch doctors of the musical world on the raw the other week by my attempt to de-bunk some of the superstitions of their craft, and consequently they have been busily engaged in a great "smelling-out" orgy. One great medicine man of music was particularly incensed at my daring to compare my pianistic efforts with those of Paderewski. He insists that the difference between myself and expert piano operators is due to their possessing what



Medicine man
of music.

he calls "soul," and objects to my contention that this alleged mystic attribute can all be reduced to pressure in lbs.-per-sq.-in. on the piano keys and to time intervals in milliseconds.

In spite of all the flood of correspondence I have received, I remain absolutely unrepentant and still insist that all art is merely applied science or, as I would prefer to call some of it, misapplied science. The famous pianist who pounds out the Lambeth Walk on the keyboard in the Queen's Hall is merely employing scientific principles of weight and measurement, although he doesn't, of course, realise it any more than the lark knows that it is employing well-recognised principles of aero-dynamics in order to get up to the height it does.

One correspondent who objected to my description of the piano as being a mechanical reproducer of music and to my assertion that it is impossible to create music without a mechanical reproducing instrument, thinks that he has caught me out by triumphantly asking what I think about the female voice divine. Unfortunately, the Editor won't allow me to express my true opinion of it on the ground that this is a respectable journal. I will content myself, therefore, with saying that the human voice with its vibrating vocal chords and resonance chambers is as much a mechanical device as the piano.

As for the "soul" business, to which I have already referred, it is true that some people, such as Bach and Ambrose, for instance, appear to have an innate gift which others cannot acquire, no matter

how hard they study, but this remark is also true of a prizefighter. It is merely a matter of the particular arrangement of the electrons which compose their brains. One day, no doubt, with a little further scientific research, we shall be able to rearrange these electrons at will by subjecting them to the influence of suitable ultra-short waves and so produce prizefighters or composers according to the needs of the moment—or even change one into the other—and so avoid the shocking waste and inefficiency of the present haphazard hit-and-miss arrangement of the human race.

To complete the rout of the musical fraternity I would like to prophesy that in less than a hundred years' time the piano, the saxophone and all the other tools of the musician will be in the museum along with the lyre and the dodo. All music will be reproduced by strictly wireless principles, using oscillating valves to create a medley of musical tones and overtones undreamt of by even the most advanced of our modern musicians.

Ye Olde Radyoe Shoppe

I AM not one of those ultra-modernistic sort of people who can see no good in anything belonging to a past age, and insist that if we must build our houses in Tudor style we should at least be consistent and leave out such modern amenities as main drainage and electric lighting. If people of this sort really want to be consistent they should eschew houses of any type and go and dwell with the beasts of the field, for it is quite impossible to build any sort of house without embodying some ideas of a past age. Even roofs and walls themselves are merely ideas borrowed from our remote ancestors of the mud-hut era, and I should like to see any of these ultra-modern gentry build a house without either roof or walls, although I must confess that in these days of dugouts and trenches we are getting pretty near it.

There are, however, very definite limits to the extent to which it is permissible to copy the style of a past age and yet still retain our self-respect, and I very definitely came up against it the other day when driving through an old-world town in Surrey. My attention was first attracted by a television aerial which appeared to have been in receipt of such strong signals from the Alexandra Palace that its vertical members had been bent to their own shape by the incoming waves.

Being of an admittedly inquisitive turn of mind I droye towards the place on which the aerial was perched, and was astonished to find a radio dealer's shop built in pseudo-Elizabethan style with which the television aerial had been designed to harmonise. Over the old-

By FREE GRID

fashioned diamond-paned window was the legend "Ye Olde Radyoe and Televysyonne Shoppe." Worse was to come, however, because no sooner had I stepped inside the shop than I was confronted by an "Elizabethan" television set with all the elaborate ornamentation of those spacious days. The crowning effort, however, was the labelling of the controls, and I had just got to "Ye Bryghtnesse Controlle" when I passed out, and it took several tankards of mead and sack to revive me.

When I finally came round I found the proprietor himself dressed, admittedly very appropriately, in doublet and ultra-shorts, ministering to my wants. The wriggles in the television aerial were, he told me, an attempt to "Elizabethanise" (what a word!) it. What incensed me most, however, was that the whole building had recently been constructed in this fashion to harmonise with the genuine old buildings in the town. I could have understood it if he had attempted to make the best job he could of an existing



genuine Elizabethan building, but to deliberately construct it! As I left him the dealer was busy tuning in "Ye Swynge Musyke."

Refainment and Soft Soap

I WONDER how many of you, as you lounge in luxurious ease listening to the B.B.C. programmes, think of the more humble cogs in the great broadcasting machine which make your enjoyment possible. I must confess that I did not do so until I was hurrying out of one of the administrative offices of the B.B.C. at Broadcasting House one evening last week, and in my haste tripped over a charlady's bucket. Accustomed as I am to charwomen of the more vulgar sort, I was astonished to be addressed in correct B.B.C. accents, the good lady apologising profusely for the unfortunate technical hitch as she picked me up and wiped me down.

Readers' Problems

A Selection of Queries dealt with by the Information Bureau, and chosen for their more general interest, is published on this page.

Pre-tuned Quality Receiver

THE illustration of our Pre-tuned Quality Receiver given in the Supplement Booklet "Better Reception" accompanying our issue of March 2nd last has led to a revival of interest in this set, and enquiries have been made for the constructional details.

Unfortunately, the issue of *The Wireless World* of September 25th, 1936, in which

Presuming the metal front panel has been earthed, hand-capacity effects are usually traceable to condenser spindles not being at earth potential so far as RF is concerned, to RF currents in the headphone leads, or to proximity of the aerial lead-in to the headphone leads, or to the operator.

Insulated extension spindles on tuning and reaction condensers should materially improve the handling of the set, and it would be worth while also to include an RF

the operator to the aerial lead then has negligible effect on the tuning.

The addition of an RF stage and attention to the other matters mentioned should go a long way towards eliminating the present troubles.

Television Interference

WHILE testing a television set with headphones connected to the output of the vision receiver a reader was surprised to hear quite strong morse signals and also what appeared to be broadcast or, at least, weak telephony. Our enquirer is interested in the probable origin of these signals.

With a superheterodyne, signals from the higher frequency end of the short-wave band may be receivable if the oscillator is working on the lower beat. It is customary to employ an IF of the order of 13 Mc/s in television sets so that the lower oscillator beat will be on or about 32 Mc/s, and signals could be received from commercial and broadcast stations work-

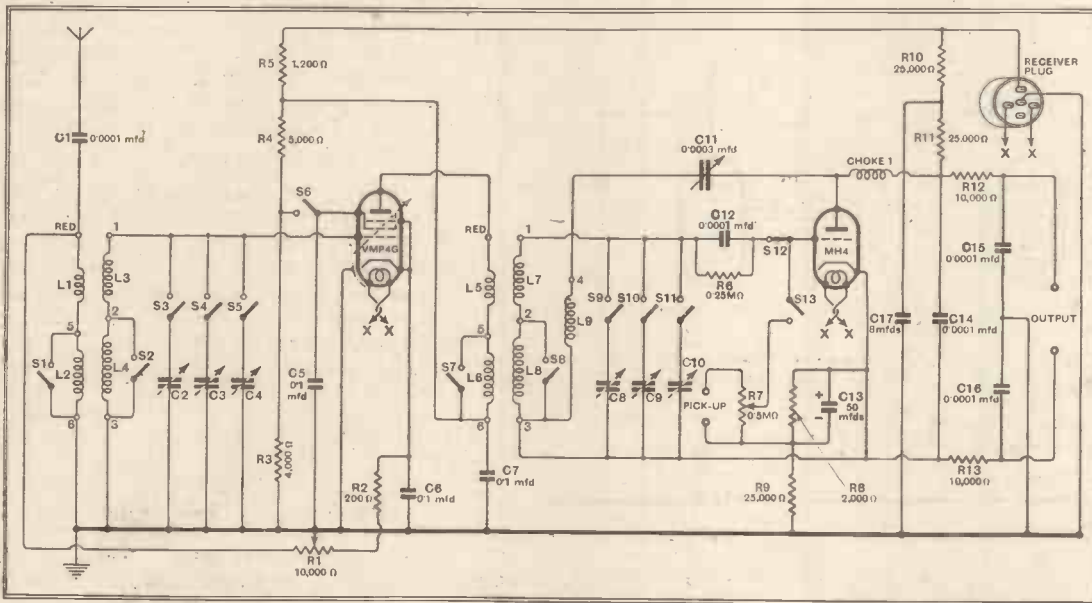

The circuit of the RF and detector portion of the Pre-tuned Quality Receiver is shown on the left, while below is the circuit of the AF amplifiers and power supply unit.

the theoretical circuit was given, and which also contained the reference numbers of the various resistances and condensers, is now out of print. It may be helpful to prospective constructors of this set, therefore, to reproduce here the complete theoretical circuit as it appeared originally.

Despite the time that has elapsed since the set was designed it is still quite suitable for the normal requirements of local station reception, and although the selection of the three pre-tuned programmes is effected by means of a switch, it possesses the essential features of the more up-to-date push-button type of receiver, but the results were obtained in a different manner.

It is not felt necessary even at this date to suggest modifications since only a very comprehensive change in the circuit would in any way improve its performance.

The AF amplifier is a modified version of the original push-pull quality amplifier, and differs only in that the components have been limited to the bare minimum. Its performance is, however, in no way impaired by this simplification.

Hand Capacity

A SHORT-WAVE receiver consisting of a detector and AF amplifier is proving rather troublesome on account of hand capacity affecting the tuning, and although a metal panel has been fitted it is still impossible to remove the hand from the dials without "loosing" the signal.

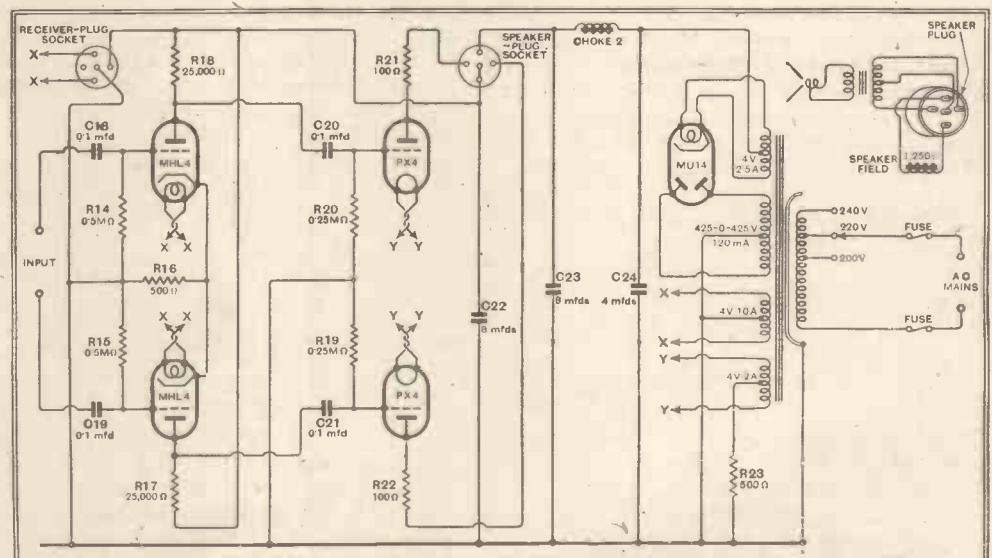

filter in the headphone leads, or alternatively use low-resistance headphones with a screened-primary output transformer.

It is our experience that a short-wave set is always more docile to handle if it includes an RF stage, as this effectively isolates the aerial from the detector valve. When the valve is oscillating, for CW reception or for searching, the oscillations are confined to this stage, and the proximity of

ing in the region of 19 Mc/s (i.e., 15-16 metres).

The RF stage, if one is fitted, would necessarily be broadly tuned, which will render it less discriminating than in a receiver designed for sound reception only. Moreover, the selectivity of ultra-short-wave tuned circuits is not high at the best of times, so that image signal interference is quite possible under certain conditions.

Letters to the Editor

The Editor does not necessarily endorse the opinions of his correspondents

Negative Feedback

IN the article, "Negative Feedback in RC Amplifiers," of the November 17th, 1938, issue of *The Wireless World*, and again in the more recent article by F. Langford-Smith, a series negative-feedback circuit is shown. This circuit is similar in principle to one developed by the writer in December, 1936, for a locally produced all-wave receiver.

It is believed that while the circuit given in the above articles is simpler, the one shown in the accompanying diagram has the advantage of giving a lower hum level when used in poorly filtered receivers. It has the additional advantage that the feedback voltage is inserted in series with both the anode load resistance and the grid leak. A disadvantage is the reduced anode voltage on V1 caused by the drop in R3.

The feedback voltage divider consists of R1 and R2. Considering the fact that R3, C1 comprise the ripple filter in the anode circuit of V1, R2 should have as low a value as possible.

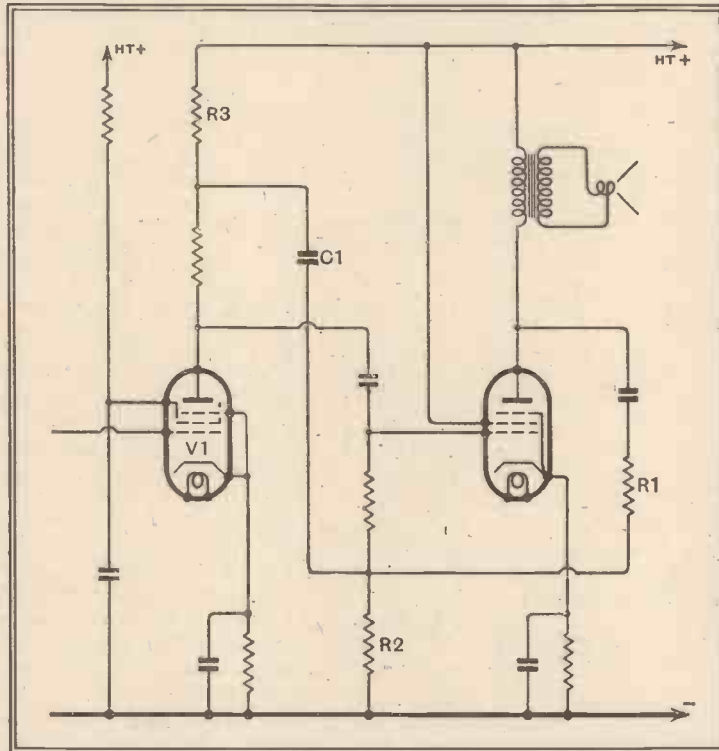

be interested in how I have reduced interference on my shaver by 85 per cent. on medium and long waves by fitting, as shown in the accompanying diagram, two external condensers, rated at the mains voltage.

From other simple experiments I have

France (Diapason Normal) $a'=435$, $c''=517$ c/s.

Germany $a'=437.5$, $c''=520$ c/s.

(The German figure is taken from the catalogue of a world-famous German maker of bassoons and other instruments. English brass bands play nearly a semitone above this group of pitches.)

Thus, theoretically the two Continental countries use lower pitches than ours, but the results of the Dutch tests (mean values 438.5, 440.4 and 441.2 c/s respectively) bear out my own more scattered experiences, and this would indicate that the adoption of $a'=440$ c/s as an International Standard would mean less hardship to those countries than one might infer from the theoretical figures. American pitch is already standardised at this value.

The experimental results also show clearly that with skilled players the initial tuning of orchestral instruments is, to a certain extent, less important than the constant endeavour of the individual performers to play in tune with one another. The uninitiated would be surprised at the amount of "cleaning-up" that can be carried out in a given chord by slight variations of lip-pressure, etc., on the part of the wind-players, in addition to the more obvious methods available in the string department.

Radio engineers and others, when discussing musical pitch, usually mutter "Middle C is 256" (i.e., $c''=512$), but this latter pitch is not used for musical purposes (unless by chance), being purely an invention of physicists, and derived from a hypothetical and inaudible low C of exactly one vibration per second.

The term "Concert Pitch" is seldom used in this sense by experienced musicians, as no fixed technical meaning has been assigned to it; it has, however, a specialised meaning (not connected with frequencies) when "transposing instruments" are being discussed, but that is another story. Musicians usually call the present English pitch either "New Phil," or "Low Pitch" or "Flat Pitch."

Rugby.

"CHALUMEAU."

Electric Shaver Suppression

BEING the user of an AC/DC electric shaver (interrupter type) for over two years, I was very interested in the letter by Mr. W. H. Pierce, published in the May 11th issue of your journal.

Having found music helped to soothe my savage beard while shaving the old soap-and-water way, I naturally suffered quite a

made, SW and especially television reception appears very badly affected by interrupter-type shaver interference. Quite a lot of direct radiation from the sparking contact appears to take place, making mains filtering on these wavelengths very difficult. Perhaps our old friends Belling and Lee will be able to assist. The requirements appear to be an easily connected universal filter, requiring no earthing, and to be especially effective on television and MW bands. Until this becomes available I shall be enforced to disturb the higher frequencies for the long period of 4-5 minutes by the clock each morning.

London, S.E.5. MARCUS GAMES.

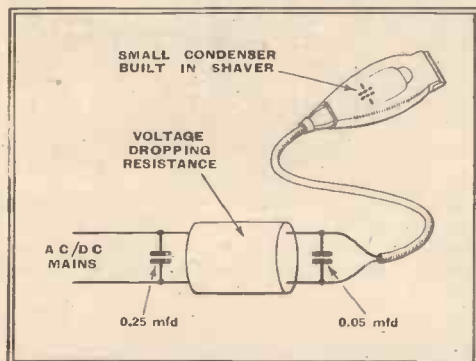

setback when using my dry shaver for the first time; not music, but interference from one end of the tuning scale to the other emerged from the loud speaker.

Other readers, especially those using interrupter type electric shavers, will no doubt

Measurement of Orchestral Pitch

THE description of the Dutch experiments published in *The Wireless World* of May 11th interested me very much, as on several occasions lately I have noticed in Continental broadcasts the use of pitches well above our own standards. In particular the Berlin Philharmonic Concert, heard via the B.B.C. last month (with Richard Strauss conducting his own compositions), was performed at a pitch quite unreachable on a wood-wind instrument of mine, although it has more than the usual scope for adjustment above the English pitch.

This has surprised me somewhat, because the standard pitches for concert use in the countries concerned have for some time been as follows:—

Great Britain (New Philharmonic) $a'=439$, $c''=522$ c/s.

Random Radiations

By "DIALLIST"

Super-power

SO Germany is to build a huge new broadcasting station, and Russia, as I gathered the other day from Moscow, is toying with the idea of a 2,000-kilowatt plant! I very much doubt whether a station with a four-figure output rating will prove worth the huge cost of its erection and maintenance. In any event, it is sure to be regarded as a nuisance by other stations on neighbouring channels, even if they are geographically at considerable distances. With enormous power behind a transmission a large spread is inevitable, at any rate when ordinary receiving gear is in use. That is

the reason why WLW7 aroused so many protests from other broadcasters that the Federal Communications Commission ordered it to reduce its output. Still, in matters of engineering the giants of to-day are apt to be the dwarfs of to-morrow. It may be that in ten years time we shall regard 100-kilowatt stations as very small beer.

■ ■ ■ Vision Over the Atlantic

IN the June issue of *Radio News* there appears a photograph of a vision viewing screen showing the historic picture from the Alexandra Palace received recently in New York. It was the first picture worthy of the name received by high-definition television across the Atlantic. In it are seen the head and shoulders of the telephone-exchange girl in "Picture Page." You can't call it exactly a flattering portrait! But it's clearly recognisable as the head and shoulders of a girl with darkish hair and wearing a light-coloured blouse thing. The image was received at the R.C.A. station at Riverhead, Long Island. The receiving aerial there is an elaborate affair some 800ft. long by 150 in width. I learn that the reception of this image was not just a single isolated instance; nothing like regular reception has been found possible, but every now and then pictures of varying quality are picked up from A.P.

Not Just Yet

Some lay writers rushed in with forecasts of regular transatlantic vision services "before very long." I am afraid that we're not likely to see anything of the kind just yet, unless the waves away down below 5 metres that are to be used for television radio links in the U.S.A. turn out to have some surprises in store for us. So far transatlantic television, even of distorted images, has been possible only when special conditions prevailed in the ionosphere; it must therefore be regarded as a "freak" affair and not as something normally to be expected, with the carrier frequency used by the A.P. transmitter at any rate.

A World Vision Standard?

It does seem a great pity that an international standard for television could not have been adopted from the outset. As matters are, all countries interested appear to be working on the interlacing system, and all, I believe, use 50 frames a second. But in the matter of lines there are two distinct camps. We, who were first in the field, plumped for 405, and the French agree with us. On the other hand, the Germans, the Americans, and peoples of other countries have standardised their systems, actual or projected, on a 441-line basis. We can't change now, in view of the assurance that has been given that no alteration will be made for some time in our method of transmission. Nor will other countries see the force of falling into line with us. At present, then, there seems to be an *impasse*; but one hopes that in years to come it may be possible for a world standard to be adopted; it would be so much to the advantage of all concerned—viewers, experimenters, and manufacturers.

Bravo!

■ ■ ■
MY warmest congratulations to *The Wireless Trader* on taking a firm stand against the sale of domestic electric appliances that cause interference with radio re-

ception. In a leading article the magazine says: "The first duty of the radio and/or electrical dealer is to do everything he can to stop people from buying and using electrical apparatus that is likely to cause interference." You couldn't ask for anything straighter from the shoulder than that, and I only hope that the said dealers will read, mark, and ACT. Many and many a wireless dealer has been doing his best to kill his own pig during the past few years by urging his customers to buy household gadgets which he knows to be strongly radiating. And one household possessing and using such things may so exasperate members of others in their immediate neighbourhood by persistent interference that several wireless sets go more or less out of action. I am convinced that the prevalence of unpleasant noises due to radiating domestic appliances is one of the main reasons why so many folk make do with ancient receiving sets. "What's the point," they say, "of buying a new set if you can't listen in comfort to broadcast entertainment?"

■ ■ ■ A Temporary Setback

PROBABLY there's nothing much to make a fuss about in the five-thousand fall in the receiving licence figures at the end of April. In the natural order of things we must be approaching the saturation point; you can't expect big monthly increases when the licences have reached 8,962,850, and the total number of homes in the country is about twelve million. It's true that this was a decrease, not an increase; but there may be a good enough explanation of that. If the district in which I live is any criterion, a larger number of people than usual moved to new homes on the March quarter-day. A considerable proportion of these would belong to the 537,571 whose licences expired in April, and prob-

ably they hadn't had time to install new sets, if the old ones had so nearly reached the pensioning-off age that they weren't worth the trouble of moving. It's possible, too, that many who have not moved house, but whose sets had become too cranky to use, decided to wait a bit before getting new ones, and have meantime let their licences lapse. I'm sure that it is only a temporary setback; there will be increases in the future, though not on the same scale as those of a few years ago.

■ ■ ■ Car Ignition Interference

IT is good to see that the British Standards Association has produced "B.S. Specification 833: Radio Interference Suppression for Automobiles and Stationary Internal Combustion Engines." This has been prepared as the result of co-operation between the Society of Motor Manufacturers and Traders, the B.B.C., the Electrical Research Association, and the G.P.O., who put their heads together to see what could be done about it. That something has been done is great. I had hoped that, having helped to evolve the specification, the S.M.M.T. would have decided to adopt it immediately for all the vehicles turned out by its members. Unfortunately, that's not the case. It is stated that we are not to expect that all new cars and lorries will immediately be fitted by their makers with suppressor devices. It is suggested that if and when legislation does come, the specification will be most useful to the industry. True; but what of the vehicles being turned out now with probably from five to ten years of radiating service ahead of them? It's a sad business, but what it seems to come to is that the motor manufacturers as a body are not going to deal with interference until they are compelled to. Ah me!

Murphy "74" Series

Quality of Reproduction the First Consideration

LAST year's A50 receiver was designed to provide reproduction of better quality than is to be found in the ordinary table model receiver, and the new A74 goes a stage further.

The five-valve superheterodyne circuit includes two IF stages and there is no RF amplifier, so that distortion due to overloading of the frequency-changer is less likely to occur. Two tuned circuits precede the frequency-changer on medium and long waves.

A four-position selectivity control gives better maximum selectivity (there are six IF tuned circuits) and a wider audio-frequency response at minimum selectivity. To avoid over-emphasis of the lower middle register on speech when using the maximum selectivity a tone-compensating network is intro-

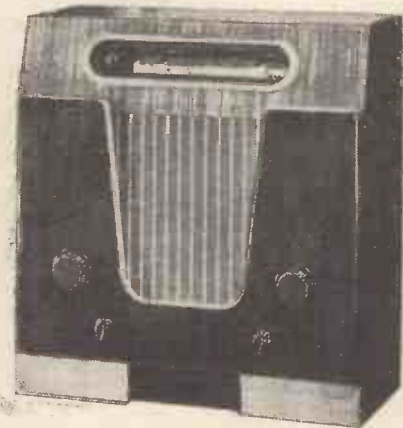

(Left) The A74 table model and (right) the A74C console. Provision for optional push-button or remote control is made in both receivers.

duced in the fourth position of the control.

The loud speaker, which has been specially designed for this set, is 10 inches in diameter and is used also in the A74C console model. Both models are adaptable for push-button or remote control, and in the console a sliding loud speaker fret is used to conceal the control-unit aperture if this feature is not required.

In addition to the usual short, medium and long ranges, the receiver covers the television sound channel. The inclusion of gramophone sockets, with suitable switching in the wave-range control, is a useful feature which has hitherto not always found a place in Murphy receivers. The price of the table model will be £16 and of the console £21.

Recent Inventions

MULTIWAVE DIPOLE AERIALS

A DIPOLE aerial is generally either a quarter or half-wave long, so that, once it is installed, any change in the working wavelength involves matching the feed-line to the new aerial impedance. This is particularly troublesome in the case of a transmitting aerial mounted on the top of a high building or mast, where it is in-

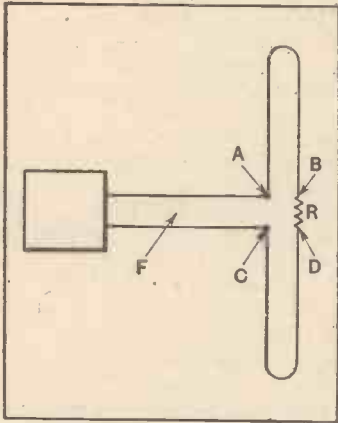

Method of maintaining constant impedance in multiwave dipoles.

convenient to carry out such adjustments.

The figure shows a "folded-over" arrangement which is equivalent to a single dipole in radiation, but for which the advantage is claimed of maintaining a constant impedance for different wavelengths. The outer ends of the two aerial limbs AB and CD are connected together through a resistance R, which is made equal to the surge impedance of the feed-line F. Under these conditions, instead of the usual stationary wave formation, a series of travelling waves are set up along each limb, moving in opposite directions from the points A and C respectively. The travelling wave system is equivalent to the usual standing wave so far as radiation is concerned, but, owing to the surge resistance R, the aerial impedance remains substantially constant over a range of wavelengths.

Soc. Anon. des Industries Radio-Electriques. Convention dates (France) June 10th, 1937, and June 8th, 1938. No. 500162.

NAVIGATIONAL BEAMS FOR AIRCRAFT

ONE method of marking-out a radio course for guiding an aeroplane in flight is to transmit two beams so that they overlap slightly. One beam is modulated with a dot-dash signal and the other with a complementary dash-dot signal, the two signals merging into a continuous note along the centre line, thereby giving an indication of the correct course to be followed.

If any conducting body is located near the beam transmitters, it is likely to reflect some of the radiated beam energy, and in

Brief descriptions of the more interesting radio devices and improvements issued as patents will be included in this section.

this way may create a "false" guiding line, along which a continuous signal note will be heard by an approaching pilot, who may thus be deceived.

The invention describes a method of radiating an auxiliary beam towards the reflecting object, and of modulating the beam in such a way that any false guiding line produced by reflection can easily be distinguished from the true one by its signal note.

Standard Telephones and Cables, Ltd. (assignées of Le Matériel Téléphonique Soc. Anon.). Convention date (France), June 11th, 1937. No. 499712.

ULTRA-SHORT-WAVE RECEIVERS

THE circuit shown is of the so-called "brake audion" type in which the incoming signals are applied through a tuned input circuit LC to the braking electrode B of a short-wave valve. The control grid G is positively biased, so that the electrons are set into oscillation about it, though there is a general "drift" towards the braking electrode. Rectification takes place between the latter electrode and a further grid D, the resulting stream being directed towards the more positively biased anode A to develop voltages across the output resistance R.

According to the invention, the biasing voltages on the electrodes are such that secondary emission takes place at the positively biased grid D, and the stream is amplified accordingly. At the same time the grid D serves as a screen between the anode A and the braking electrode B, and thus

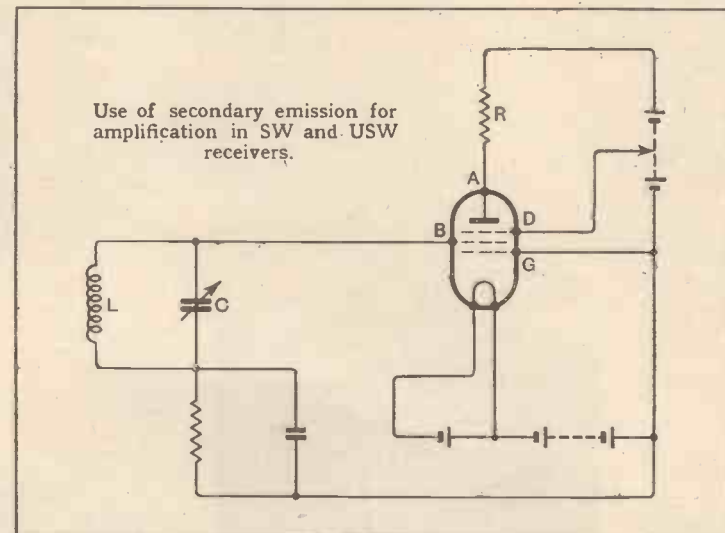

Use of secondary emission for amplification in SW and USW receivers.

prevents undesirable back coupling between the input and output circuits

Telefunken Ges. für drahtlose Telegraphie m.b.H. Convention date (Germany) July 27th, 1936. No. 499877.

PROJECTOR TUBES FOR TELEVISION

THE figure shows an electrode arrangement used for the final acceleration of the electron stream in a television receiving tube of the so-called projection type. The tube is designed to produce on the screen S, which is four centimetres square, an image in which each picture point, one-tenth of a millimetre in diameter, has an intensity of approximately 10 candle-

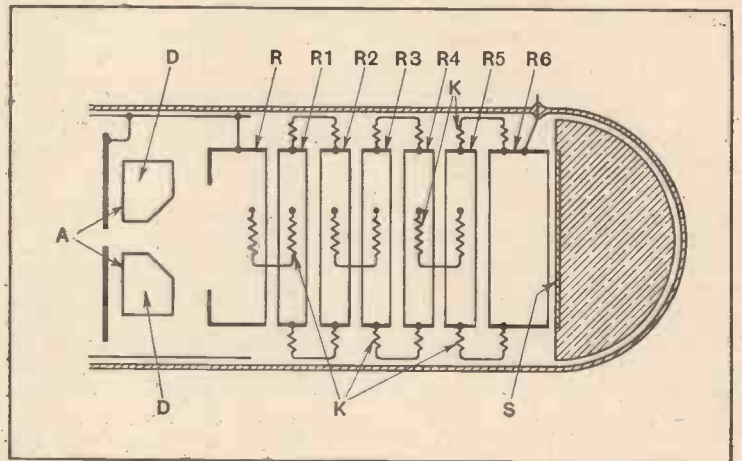

Arrangement for accelerating the electron stream in projection-type tubes.

power. This allows a large degree of optical magnification to be applied before projecting the picture on to the final viewing screen.

To secure the necessary velocity of impact on the screen, the elec-

order of 15000. The biasing voltages are derived from a series of potentiometer resistances K, which are arranged in parallel and connected to equally-spaced points around each ring. To prevent distortion the current dissipated in the potentiometer system must be at least three times greater than that of the electron beam through the cathode-ray tube.

Radio-Akt. D.S. Loewe. Convention date (Germany) July 28th, 1936. No. 499815.

SUPERHET CIRCUITS

A TETRODE valve, with the upper grid positively biased to give a dynatron action, is used

as the local oscillator in a superhet receiver, and is found particularly suitable for applying automatic tuning correction. The ATC voltage is derived from a pair of balanced error-detecting circuits in the usual way, and is applied to the control grid of the dynatron oscillator.

The arrangement is intended for receiving short-wave signals of the order of 5 megacycles, though it gives satisfactory results at 100 kilocycles, correcting any frequency "drift" up to 200 parts in a million.

As compared with the more usual method of applying the ATC voltage to a control valve, which then serves to vary the tuning of a back-coupled oscillator, the present circuit is not only a simpler arrangement but also avoids undesirable damping of the tuned oscillator circuit.

Standard Telephones and Cables, Ltd.; R. M. Barnard and W. Kram. Application date August 30th, 1937. No. 501529.

The British abstracts published here are prepared with the permission of the Controller of H.M. Stationery Office, from specifications obtainable at the Patent Office, 25, Southampton Buildings, London, W.C.2, price 1/- each.

tron stream, after it has passed through the anode A and deflecting plates D, is accelerated by progressively increasing voltages applied to a series of ring electrodes R, R1, R2, etc., the voltage on the last ring, R6, being of the



**Are our
Condensers &
Resistances
the most
reliable?**

If we said quite simply, "Yes, they are," and left it at that, you probably wouldn't believe us—and we wouldn't blame you. Then, what proof can we give you? Well, our range of fixed and variable resistances is the largest of any British manufacturer—we've been making Condensers for every electrical purpose for many, many years now—through all those years we have concentrated above all on reliability. Are you convinced? If not, may we add this—"The Wireless World" have specified 16 Dubilier Condensers and 18 Dubilier Resistances for their Cathode Ray Oscilloscope. And you know as well as we do that you can't take chances with condensers and resistances in Electronic Apparatus. Convinced now?

DUBILIER

CONDENSERS AND RESISTANCES

DUBILIER CONDENSER CO. (1925) LTD.
DUCON WORKS, VICTORIA ROAD, NORTH ACTON, LONDON. W.3.



C. R. Casson 148

G.E.C. CATHODE RAY MONITOR TUBE



TYPE 4081
2 3/4 inch Screen

The handy and efficient Tube for all general oscillographic purposes.

- Low operating voltages.
- High spot brilliance.
- Fine Focus.
- High sensitivity for short length.

Write for Technical leaflet
OV.8698

PRICE 55/- each

Adv. of The General Electric Co. Ltd., Magnet House, Kingstway, London, W.C.2.

IMPORTANT in their respective SPHERES

New TROPHY 6

Here is a new All-British and sensationally low-priced junior communications receiver for all short-wave enthusiasts. Note TROPHY 6 features:

- 6-valves—Octal types.
- Wave-range 6.5 to 545 metres.
- Separate dial Electrical Band spreading.
- Directly calibrated frequency scale.
- AVC, BFO, Send/Receive Switches.
- Pitch control.
- Built-in speaker and 'phone jack.

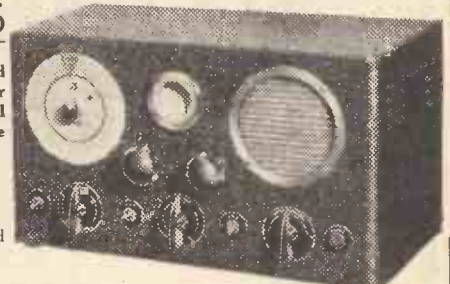

The TROPHY 6 is an amazing performer over the complete coverage and is presented for general approval with utmost confidence. **9 1/2 GNS**

TERMS: 12/6 deposit and 18 monthly payments of 12/3

FOR ALL RECEIVERS TROPHY PRESELECTOR

This new pre H.F. amplifier with a wave range of 7 to 550 metres, employs two EF8 low-noise RF Pentodes and is confidently recommended for use with any type of receiver where increased range, selectivity, signal strength and image suppression are desired.



£6.15s.

Self-powered for all A.C. voltages between 200 and 250.

TERMS: 11/3 deposit and 12 monthly payments of 11/7.

• May we send you all TROPHY Lists?

WIRELESS WORLD CATHODE RAY OSCILLOSCOPE Time Base & Amplifier

PILOT KIT 'A' Cash, C.O.D. £73.6

Comprising all parts for Time Base and Amplifier only, to "Wireless World" specification, including Mains Transformer, Chassis, Peto-Scott switch, wire and sleeving but less all valves. TERMS: 12/6 deposit and 12 monthly payments of 12/5.

OSCILLOSCOPE

PILOT KIT 'A' Cash, C.O.D. £4.10.0

Comprises all components for Oscilloscope only, including Mains Transformer, Chassis Assembly, wire, flex and screws but less valve and Cathode Ray tube. TERMS: 8/- deposit and 12 monthly payments of 7/10.

COMPLETE KIT - - £17.8.0

Comprising all parts supplied in above "A" Kits but including all specified valves and Cathode Ray Tube. TERMS: £4/10/0 deposit and 12 monthly payments of £1/4/3.

PETO-SCOTT Co. Ltd. 77 (WW17) City Road, London, E.C.1. Tel.: Clissold 9875
41 (WW17) High Holborn, W.C.1. Tel.: Holborn 3248

Mention of "The Wireless World," when writing to advertisers, will ensure prompt attention.

IF YOUR SET BRINGS IN
SHORT-WAVES YOU OUGHT
TO SEE THE NEW

American Page

This is a quick reference guide to the pick of the U.S. short-wave programmes, given hour-by-hour for each day of the week. You will find this a help in two ways: it will add to your enjoyment of American programmes by showing you the "high-spots" and it will save you wasting time (and temper!) in aimless searching.

Your local newsagent or bookstall has a copy ready for you.

World - Radio

THREEPENCE EVERY FRIDAY

B.I. CONDENSERS

for
RADIO & GENERAL USE

B.I. CONDENSERS for Radio Receivers, Battery Eliminators, Smoothing Circuits, etc., are made in several different types to suit the various uses for which Condensers are required in connection with Wireless circuits.

These Condensers are the result of 36 years' experience in the manufacture of all kinds of Condensers from the smallest sizes up to those weighing more than 2 tons.

In addition to the Standard Types, B.I. Condensers can be supplied in special forms to suit manufacturers' requirements.

The illustration shows Type 212 recommended for use with eliminators.



BRITISH INSULATED CABLES LTD.

Cable Makers and Electrical Engineers

PRESCOT, LANCS.

Telephone No.: PRESCOT 6571.

London Office: SURREY HOUSE, EMBANKMENT, W.C.2

Telephone No.: Temple Bar 7722

FOURTH EDITION

Revised and Enlarged
with 50 additional
pages

WIRELESS SERVICING MANUAL

By W. T. COCKING (of "The Wireless World")

The most complete book of reference of its kind. A reliable practical guide for amateur and professional.

The present edition brings the material of the book up to date and includes an additional chapter on television receivers which is practically the only source of servicing information available on this subject.

Ganging, Automatic Volume Control, Instability, Distortion, Mains Hum, Whistles and Local Interference, all are separately treated.

Information on short-wave receivers, and on methods of operating extension loud speakers is included, as well as a special chapter on the Aerial-Earth System. The reference material, including base-connections for British, Continental and American valves and the various colour codes for components, has been extended and brought up to date.

BOUND IN CLOTH BOARDS
SIZE 7½ ins. x 5 ins.

5/- net. By post 5/5

Issued in conjunction with "THE WIRELESS WORLD" and published by the Proprietors:—

LILFE & SONS LTD., DORSET HOUSE, STAMFORD STREET,
LONDON, S.E.1.

CLASSIFIED ADVERTISEMENTS

NOTICES

THE CHARGE FOR ADVERTISEMENTS in these columns is 12 words or less, 3/- and 3d. for every additional word.

Each paragraph is charged separately and name and address must be counted. The proprietors retain the right to refuse or withdraw advertisements at their discretion.

Postal Orders and Cheques sent in payment for advertisements should be made payable to ILLIFFE & SONS, Ltd., and crossed & Co. Notes being untraceable if lost in transit should not be sent as remittances.

ARMSTRONG'S NEW HEADQUARTERS



After many years at our old premises in Camden Town we have moved our Offices, Showrooms and Development Department to a modern building centrally situated in

WALTERS ROAD, HOLLOWAY, N.7 (Adjoining Holloway Arcade).

Send for Illustrated Catalogue of our full range, which includes the following outstanding chassis:

MODEL AW125PP . . . Price £17.17.0

12-V. ALL-WAVE RADIOGRAM CHASSIS

5 wavebands, 12-550 continuous, 1,000-2,000 m., R.F. Pre-Amplifier, 2 I.F. stages with Variable Selectivity. Manual R.F. gain control and 10 watts R.C. coupled Triode P.P. output.

MODEL AW93PP . . . Price £10.10.0

9-V. ALL-WAVE RADIOGRAM CHASSIS

3 wavebands, R.F. Pre-Amplifier, 3 stages of A.V.C. and 8 watts R.C. coupled Triode P.P. output.

MODEL RF96 Price £8.0.0

6-V. ALL-WAVE RADIOGRAM CHASSIS

Complete with Matched M.C. Speaker. Incorporating R.F. Amplifier. 3 wavebands, 17.9-50, 200-550, 1,000-2,000 m., 3 stages of A.V.C., corrected 3 1/2 watts output.

All communications to be addressed to: ARMSTRONG MANUFACTURING CO., WALTERS ROAD, HOLLOWAY, LONDON, N.7 (Adjoining Holloway Arcade).

Telephone: NoRth 3213.

BOOKS ON WIRELESS

Write for complete list to Illiffe & Sons Ltd., Dorset House, Stamford St., London, S.E.1 W.W.1

NOTICE

There appeared in the issue of "The Gramophone" of April 1939 a statement to the effect that British Ozaphane Limited had discontinued the manufacture of the "DUO-TRAC" Cell-o-phones and Sound Reels.

The Proprietors of "The Gramophone," General Gramophone Publications, Ltd., 10a, Soho Square, London, W.1, greatly regret the publication of the above statement which they are informed has no foundation in fact and apologise to British Ozaphane Limited for having published the same.

British Ozaphane Limited state that far from having discontinued the manufacture of the "DUO-TRAC" Cell-o-phones and Sound Reels, the Company is going well ahead with the marketing of these instruments not only at home but also in South Africa, Australia and other parts of the British Empire. In addition this Company states it has a comprehensive catalogue of instruments and recordings available, including in the latter the latest dance hits.

ADVERTISEMENTS for these columns are accepted up to FIRST POST on MONDAY MORNING (previous to date of issue) at the Head Offices of "The Wireless World," Dorset House, Stamford Street, London, S.E.1, or on SATURDAY MORNING at the Branch Offices, 8-10, Corporation Street, Coventry; Guildhall Buildings, Navigation Street, Birmingham, 2; 260, Deansgate, Manchester, 3; 26s, Renfield Street, Glasgow, C.2.

The proprietors are not responsible for clerical or printers' errors, although every care is taken to avoid mistakes.

For particulars of Box Number Advertisements and Deposit System see previous issues.

PUBLIC ADDRESS

VORTEXION P.A. Equipment. IMITATED, but unequalled.

WE Invite You to a Demonstration. A.C.-D.C. Dance Band Amplifier, 10-watts output, complete in case, with moving coil microphone, speaker and cables, weight 22lb., 12 gns.

A.C.-20 15-20-watt Amplifier, 38-18,000 cycles, independent mike and gram, inputs and controls, 0.037 volts required to full load, output for 4, 7.5, and 15 ohms speakers or to specification, inaudible hum level; ready for use; 8 1/2 gns., complete.

C.P. 20, 12-volt battery and A.C. mains model, as used by R.A.F., output as above; 12 gns.

A.C.-20, in portable case, with Collaro motor, Piezo pick-up, etc., £14; C.P.20 ditto, £17/17.

50-WATT Output 6L6s, under 60-watt conditions, with screen and bias, with better than 4% regulation, level response, 20-25,000 cycles, excellent driver, driver transformer, and output transformer matching 2-30 ohms impedance electronic mixing for mike and pick-up, with tone control, complete with valves and plugs; £15.

COMPLETE in Case, with turntable B.T.H. Piezo pick-up and shielded microphone transformer; £20.

80-WATT Model, with negative feed back; £25, complete.

120-WATT Model, with negative feed back; £40, complete.

250-VOLT 250 m.a. Full Wave Speaker, field supply unit; 25/-, with valve.

ALL P.A. Accessories in Stock; trade supplied. VORTEXION Ltd., 182, The Broadway, Wimbledon, S.W.19. Phone: Lib. 2814. [824]

PARTRIDGE P.A. Manual, free to trade, from N. Partridge, B.Sc., A.I.M.E.E., King's Buildings, Dean Stanley St., London, S.W.1. [0631]

QUALITY Amplifiers and Microphone Equipments for Hire or Permanent Installation.—Harmony House, 116, Cambridge Rd., Southport. [8505]

ALEXANDER BLACK, Ltd.—Consult us on sound installations, temporary or permanent; booklet on request.—55, Ebury St., S.W.1. Sloane 6129. [0597]

PUBLIC Address Contractors Can Hire P.A. Vans, loud speakers, microphones and equipments of all types from Hire Dept., Gramplan Reproducers, Ltd., Kew Gardens, Surrey. Tel.: Richmond 1175-6-7. [0618]

RIBBON Microphone, 7 models, from £3/19/6, list free; 15-watt, high gain, high fidelity, 4-stage amplifier for ribbon microphones, £12/10; 30-watt ditto, £18.—Holiday and Hemmerdinger, Ltd., 74, Hardman St., Manchester. [8475]

PARTRIDGE 12-watt P.A. Amplifier, built in strong wooden portable case, complete with valves, £6/15; Gramplan moving coil microphone, chromium foil, stand, and Partridge mike transformer, 70/-; Rothermel Radio Heart Tuning unit (using English valves), 39/6; all above perfect, very little used.—121, Adnitt Rd., Northampton. [8511]

NEW MAINS EQUIPMENT

VORTEXION Supply G.P.O., B.B.C., L.P.T.B. Why not you?

ALL Models Super Shrouded, primaries screened and tapped, 200-250v., filaments C.T. NY Model Fitted 5v. or 6.3v. Filaments if Required.

500-0-500 150 m.a., 4v. 4a., 2.5a., 4v. 2a., 4v. 2a., 4v. 2a., 35/-; 400 or 350v., same price.

500-0-500 120 m.a., 4v. 4a., 4v. 2.5a., 4v. 1-2a., 4v. 1-2a., 28/-; 400v. or 450v., same price.

425-0-425 150 m.a., 4v. 8-10a., 4v. 2.5a., 4v. 1a., 4v. 1a., 32/-.

350-0-350 120 m.a., 4v. 4a., 4v. 2.5a., 4v. 1-2a., 21/-; with extra 4v. 6a., 25/-.

350-0-350 75 m.a., 4v. 2.4a., 4v. 1-2a.; 18/-.

250-0-250 60 m.a., 4v. 2-4a., 4v. 1-2a.; 15/-.

AUTO Transformers, 100-120 to 200-240v., 80 watts, 11/-; 120 watts, 14/6; 200 watts, 21/-; 250 watts, 25/-; 300 watts, 28/-; 500 watts, 47/6.

W.W. Q.A. Output Transformer; 21/-.

MICROPHONE Transformers, in heavy magnetic shielding; 12/6.

CHOKES.—30h. 60 m.a., 7/6; 7-13h. 120 m.a., 12/6; 30h. 150 m.a., 15/-; 25h. 150 m.a., 21/-.

NEW RECEIVERS AND AMPLIFIERS

RADIO CLEARANCE, Ltd., 63, High Holborn, W.C.1. Telephone: Holborn 4631.

BRITISH Belmont 8-valve Plus Magic Eye All-wave A.C. Superhet Chassis, 4 wave bands, 2 short medium and long, fitted latest Mullard octal base American type valves. Brief specification: Short wave 6.18 metres (covers television sound), short wave 2, 18.50 metres, medium band 200-550 metres, long 900-2,000 metres; valve combination 6K7 Pre H.F., 6J7 oscillator, 6J7 mixer, 6K7 I.F., 6Q7 (DDT) detector, A.V.C. and first L.F., two 6F6s, parallel output, 5Y3 rectifier, plus 6G5 Magic Eye visual tuning, handsome dial, station names etched on glass, controls 2-speed tuning, volume and on-off, combined variable tone control and selectivity switch, wave change plus gramo. switch; size of chassis 13 1/2 in. x 10 in. x 3 in., supplied complete with valves, escutcheon, knobs, but less speaker, £5/19/6 each; complete receiver in handsome walnut cabinet, details as above, complete with speaker, £7/17.

DECCA 8-valve 3-waveband Battery Chassis, fitted complete with Mazda and Osram valves, QPP output; these chassis give a sparkling performance on all wavebands, and are the product of a well-known manufacturer, complete with valves, £3/3 each; complete receiver in handsome walnut cabinet, details as above, complete with speaker, £3/19/6 each.

ALL the Above Fitted Ring Valves Throughout. SEE Our Advertisement under Components.

RADIO CLEARANCE, Ltd., 63, High Holborn, W.C.1. Telephone: Holborn 4631. [8502]

DEGALLIER'S "Challenge Radio Corporation."

SEND 2d. stamp for Handsome Illustrated Catalogues. Telling of our Superb Range of Receivers; direct public sales policy (saves you 40%), most exceptional value on the market, from a T.R.F. Midget at £3/5 to a 19-valve general purpose receiver, 6 bands, with two P.A. speakers, at 30 gns.; 6-page brochure of Wireless World on this set is available; car radio; any known American valve, all 5/6 each; also American P.A. speakers, cabinets, and the Challenger 6-valve A.C. tuning unit, 6 bands 6-10, 12.8-50, 65-200, 190-550, 900-2,000 metres. Hours business 11 a.m. until 9.30 p.m.

DEGALLIER'S 31, Craven Terrace, London, W.2. Paddington 6492. Nearest point Lancaster Gate Tube Station. [8515]

HOWARD 438 8-tube 4-band Communication Receiver, 7-550 metres, with matched crystal and R. meter; £19/19.—Superadio, Dantzic St., Manchester. [8510]

ARMSTRONG Co.—After many years at our old premises at Camden Town we have moved to a new building in Walters Rd., Holloway, N.7 (see displayed advertisement).

ARMSTRONG Amplifier Division Has Moved to New Premises at 94, Camden Rd., N.W.1. Enquiries for High Fidelity amplifiers and simple feeder units should be made to this address. Catalogue of this apparatus will be forwarded free to those interested.

ARMSTRONG Co. (Amplifier Division), 94, Camden Rd., N.W.1. [8518]

BATTERY CHARGING PLANT

MILNES Units, 120v. Minor, 30/-; 165v.+9v. Minor, £2; 135v. Minor, 35/-; little used; Milnes 6v. charging batteries, 10/- each.—Chattell, 40, High St. North. Dunstable. [8508]

USED SETS FOR SALE

SCOTT Wanted SCOTT Imperial or Philharmonic (chassis or radiogram), good cash price.—Box 9918, c/o The Wireless World. [8507]

CAR RADIO

NEW Caradios from £4/10; used caradios from £3.—41, Glebe Avenue, Kenton. [8482]

CROSLLEY Push-button 1939 10-guinea Models, 5 1/2 gns.; aeriels, overheads, police type, etc., from 8/6; trade enquiries solicited.—Shippers, 18, Corporation St., Manchester. [0622]

FINEST American Twin Running-board, Aeriels, completely rubber covered, maximum signal pick-up, minimum noise, easy mounting, now only 17/6 pair complete; handsome chromium roof aeriels, to mount straight or "vee," complete, 15/-; immediate despatch, carriage paid; cash with order or c.o.d.

WIRELESS SUPPLIES UNLIMITED, Essex House, Stratford, E.15. Maryland 3191. [0577]

FRONT PAGE NEWS AGAIN!

On the front cover of "The Wireless World," May 18th, you will notice that the SOUND SALES Choke figures prominently on the illustration of the D.C. "Mains Super." The Choke is our type S.S. 68/150 specified for the D.C. Quality Amplifier and is priced at 15/-.

The significance of SOUND SALES components on Quality Apparatus will be obvious to all users of S.S. products. Like everything else, we produced the "S.S. 68/150" Choke as an engineering job—there is nothing more deceptively simple than a choke, just a lot of wire and iron—the cheaper the choke the greater the resistance thereof, and greater the loss. YOU cannot afford to lose valuable volts from D.C. mains, hence the substantial design of the low resistance high efficiency choke shown in the illustration.

May we send YOU further details, also our latest Catalogue and Technical Manual, Price 6d.

Specified by the Experts

SOUND SALES

MARLBOROUGH RD. UPPER HOLLOWAY, LONDON, N.19. (Contractors to the G.P.O., etc.) LIMITED. Tel.: Archway 1661/2/3

Hours of Business—
Monday to Friday, 8.30 a.m. to 6 p.m.
SATURDAYS CLOSED

RADIOMART

G5NI (BHAM) LTD.

THE SHORT-WAVE SPECIALISTS

SPECIAL OFFER!!!
Fully shrouded Transformers by America's largest manufacturer. While they last.

All 230 v. primary and fully impregnated.

T28708—375/375 v. 150 m/A. 6.3V5A. 2.5V2A. 5V3A.	15/-
T19610—350/350 v. 150 m/A. 2.5V6A. 2.5V2A. 5V3A.	12/6
T7236—375/375 v. 120 m/A. 6.3VCT. 4A. 5V3A.	10/6
T7326—350/350 v. 100 m/A. 6.3VCT. 3A. 5V3A.	8/6
T7307—350/350 v. 80 m/A. 6.3VCT. 3A. 5V3A.	7/6
T7000—320/320 v. 80 m/A. 6.3V4A. 5V3A.	7/8
T6925—320/320 v. 80 m/A. 2.5V6A. 5V3A.	7/6
T464910—10V4A Primary Tapped 110—250 v.	5/6
T1113AB—110/230 v. 500 wats Auto Transformer.	29/6

The following chokes are interleaved and impregnated.

T7007—250 m/A. 135 ohms, 20-8 Hy., cadmium shrouded.	12/6
T7007A—150 m/A. 250 ohms, 30-12 Hy., cadmium shrouded.	12/6
100 m/A. 20 Hy., 500 ohms, unshrouded.	4/11
60 m/A. 15 Hy., 250 ohms.	1/11

HEAVY DUTY TRANSFORMER for models, bells, etc. 6 v. 3 a., 2/3. 4 mf., 1,500 v. test 500 v. v.c.e. oil filled condensers, 2.

HEAVY DUTY mains transformer, worth 45/-, 350-350 150 m/A. 4 v. 2.5 a. CT. 4 v. 6 a., CT. 12/6; 300-300 v. 80 m/A. 4 v. 3 a., CT. 4 v. 2.5 a. CT. 6/6. Moving Coil Speech Transformers. 1/11.

GANG CONDENSERS with Airplane Dial, 8 and 80-1. Cost 35/-. Few only. 4/11. Utility, 7/6. Microdials, 3/9.

W.B. 8in. PERMANENT MAGNET SPEAKERS AT ONE-THIRD COST Extension Type (no Transformer), 8/11. Standard Type (with Transformer) 10/6. Energised 8", 1,200 ohms with Transformer, 6/11.

PUSHBACK Wire, 6 yds., 6d., heavy 9d. Resin-cored Solder, 6ft., 6d.; Screened Flex, single, 6d. yd.; twin 9d. yd. Assorted Solder Tags, 6d. packet. Humdimmers, 6d. each.

Centralab pots, all sizes, 1/6; switched, 2/-; tubular caps; fuses, 2d. Milliammeters, 0.25 m.a., upwards, 5/9; Super, 6/9.

OUR NEW 66-PAGE MANUAL, packed full of valuable information. Post Free, 7/6.

THE NEW RAYMART CATALOGUE shows dozens of New Short-wave components and is yours for 11d. post free.

VALVES—A complete range of replacements, showing a saving of over 50 per cent. Quotations on receipt of types required. Quantity Discounts to Service Engineers. Trade enquiries for communication equipment solicited.

RADIOMART Telephone: MIDland 324
G5NI (Birmingham) Ltd.
44, HOLLOWAY HEAD, BIRMINGHAM

We do quite a lot of business making up transformers to customers' own specifications; but we have a standard list. May we send you a copy?

W. BRYAN
WIMBORLAND RD., LONDON N.W.9

SAVAGE LTD
PHONE, COLINDALE 7131

NEW LOUD-SPEAKERS

SINCLAIR Speakers for All Types.—Alma Grove, Copenhagen St., N.1. [0603]

BAKER'S New Corner Horn Speakers, triple cone conversions, from 29/6; and surplus speaker bargains.—Details free from Bakers Selhurst Radio, 75, Sussex Rd., South Croydon. [8512]

LOUD-SPEAKERS

SECOND-HAND, CLEARANCE, SURPLUS, ETC.

ROLAS for 6/11; G12's, 47/6; 1/4d. stamp for lists.—Shippers, 18, Corporation St., Manchester. [0606]

VAUXHALL UTILITIES, 163a, Strand, W.C.2.—Rola G12 P.M. speakers, 62/6; G12 energised, 50/-; with transformers, brand new. [8499]

3,000 Speakers from 5/6 each, P.M. and energised, 4in. to 14in., including several Epoch 18in.—Sinclair Speakers, Alma Grove, Copenhagen St., N.1. [0591]

LOUD-SPEAKER CONVERSIONS

EPOCH Domino Loudspeakers can Now be Converted to the Famous "NEW" Super Cinema Speaker with 14in. Cone, replacement for all Epoch speakers, also output transformers; a genuine Epoch hand-made cone for any speaker.

HALFORD DISTRIBUTORS, Ltd., 31, St. George St., W.1. Sole manufacturers of Epoch loudspeakers and the famous Halford Phantom radio set. [0632]

TRANSMITTING APPARATUS

A.C.S. RADIO, specialists in short-wave apparatus, A communication receivers, including Hallicrafters, National and R.M.E. transmitting equipment, valves and components.—Send for free catalogue to A.C.S. Radio, 16, Gray's Inn Rd., W.C.1. Holborn 9894-5. G2NK. Technical Manager. [0550]

G5NI—The oldest and largest distributor of amateur equipment, transmitting and receiving; short-wave catalogue, 1/4d.; G5NI 70-page Manual, 7/4d., post free; authorised direct distributor for Collins, National, R.M.E., Thordarson, Hammerlund, Biley, Taylor, Eimac, etc., etc.—44, Holloway Head, Birmingham. [0531]

CABINETS

A CABINET for Every Radio Purpose.

CONVERT Your Set into a Radiogram at Minimum Cost; surplus cabinets from noted makers under cost of manufacture (undrilled); 30/- upwards; motors at wholesale price.

"FIT-A-GRAM" Cabinet, 31 x 17 x 15; 21/-.

UNDRIILLED Table-Console and Loud-speaker Cabinets, from 3/6.

INSPECTION invited; photos loaned to country customers.

H. L. SMITH and Co., Ltd., 289, Edgware Rd., W.2. Tel.: Pad. 5851. [0485]

DYNAMOS, MOTORS, ETC.

D.C.-A.C. Convertors, motors, all voltages, for sale and wanted.—Easco, 18w, Brixton Rd., S.W.9. [0558]

ALL Types of Rotary Convertors, electric motors, battery chargers, petrol-electric generator sets, etc., in stock, new and second-hand.

A.C.-D.C. Conversion Units for Operating D.C. Receivers from A.C. Mains, 100 watts output, £2/10; 150 watts output, £3/10.

WARD, 46, Farringdon St., London, E.C.4. Tel.: Holborn 9703. [0518]

ELECTRADIX Rotary Convertors for A.C. Radios on D.C. mains; alternators 50 to 500 cycles; mains motors and motor generators for 1 to 600 cells; petrol engines and switchgear.—218, Upper Thames St., London, E.C.4. [0619]

RECORDING EQUIPMENT

ALL Recording Discs and Materials in Stock; tracker units, £4/7/6; recording motors, £3/17/6.—Write for further details, Will Day, Ltd., 19, Lisle St., W.C.2. [0595]

VALVES

ALL Types of American Tubes in Stock of Impex and Arcturus makes at competitive prices.

WE Can Also Supply a Full Range of Guaranteed Replacement Valves for Any British non-ringing American or Continental type at an appreciably lower price.

SEND for Lists of These, and also electrolytic condensers, S line cords, resistances, etc.

CHAS. F. WARD, 46, Farringdon St., London, E.C.4. Tel.: Holborn 9703. [0452]

AMERICAN Valves, first grade, by leading makers, guaranteed, popular types; standard base 5/6; octal base 6/6; 6L6G, 7/6.—General Radio Distributors, 309, Falden Way, N.W.11. [0626]

2/9 R.C.A. American Valves, 50 popular types, also National Union, Hytron, also British non-ringing valves, cheapest in Britain; 1/4d. stamp for revised lists.—Shippers, 18, Corporation St., Manchester. [0607]

METROPOLITAN RADIO SERVICE—Special offer: American valves, in makers' cartons, 3/- each; Octals, 3/6 each; American valves, first grade, in all types; trade supplied.—1021, Finchley Rd., N.W.11. Speedwell 3000. [0436]

COMPONENTS

SECOND-HAND, CLEARANCE, SURPLUS, ETC.

RADIO CLEARANCE, Ltd.

ALL Lines Previously Advertised Still Available.

RADIO CLEARANCE, Ltd., 63, High Holborn, W.C.1. Holborn 4631. [8470]

SOUTHERN RADIOS Bargains.—Sale now proceeding of hundreds of bargain lines, goods previously advertised still available.—Southern Radio, 46, Lisle St., London, W.C.1. Gerrard 6653. [8236]

Test with the Best—

The 46-RANGE UNIVERSAL

AVOMETER

Read Trade Mark Model 7
Electrical Measuring Instrument

BRITISH MADE

SERVICE jobs lose half their worries and laboratory tests are completed in half the time with the Model 7 Avometer. Dead beat in action, it quickly gives laboratory-accurate readings on all its 46 ranges. A.C. and D.C. amperes and volts, resistance, capacity, audio-frequency power output and decibels—any range instantly selected by means of two rotary switches. No external shunts or resistances required. A protective cut-out instantly disconnects the meter from the supply should a severe overload be applied. It is built to last with lasting accuracy.



Write for Descriptive pamphlet.

16 Gns. Model 7. Resistance Range Extension Unit (for measurements down to 1/100th. ohm) 12/6	Also the 36-range Universal Avometer ... 13 Gns.
	22-range D.C. Avometer ... 9 Gns.
	Carrying Case ... 25/-
	DEFERRED TERMS IF DESIRED.

Sole Proprietors and Manufacturers:—

THE AUTOMATIC COIL WINDER & ELECTRICAL EQUIPMENT CO. LTD., Winder House, Douglas Street, London, S.W.1. Phone: VICtoria 3404-7.

STRIPS

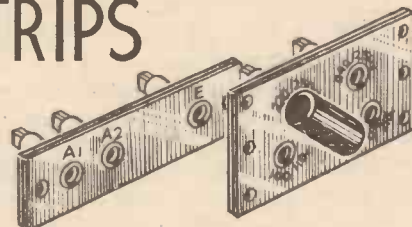

The standard stock types of CLIX Chassis Mounting Strips include those having from two to six sockets. These embody the CLIX patent Resilient turned Sockets with screw or soldering terminals and appropriate markings.

CLIX Voltage Selector Panels provide a speedy and safe means of selecting the required voltage from a series of mains supplies. For full details see CLIX Annual Catalogue, 1939 Edition.

CLIX

British Mechanical Productions Ltd., 79, Rochester Row, London, S.W.1.

WELBURN 12 WATT AMPLIFIER

Designed and built for consistent hard work. Reliability and first class performance on both speech and music were our first consideration.

NOTE THESE POINTS:
No distortion; No hum; Cool running; Small input (only 0.008v); Output 12 watts; Overall Gain 116dBs; No pre-amplifier required. Linear Amplification combined with Level Response; Mike-Gramo-Mixer; Mazda Valves; Self-contained in dust-proof steel case.

A SOUND JOB FOR ALL SOUND PURPOSES
Write for 12 pp. descriptive brochure

RETAIL PRICE **£14**



WELBURN RADIO LTD
QUEENSWAY, TEAM VALLEY
GATESHEAD-ON-TYNE

COMPONENTS—SECOND-HAND,
CLEARANCE, SURPLUS, ETC.

PREMIER SUPPLY STORES.

PLEASE See Our Displayed Advertisement on this page.
[0488]

RYALLS RADIO, 280, High Holborn, London, W.C.1,
offer new goods, post free.

ELLIPTICAL Speakers, Celestion, suitable Ekco replacement, 750 and 1,250 ohms, less transformers, speech 25 ohms, new, handle 8 watts, carry up to 120 m.a.; 5/6 each.

NEW Ferranti Transformers, AF5, OPM16c (15/22/45-1), AF6c, OPM15c, OPM5 (4/7/10-1), AF15c, OPM6; all 6/9 each.

GARRARD AC Induction Type AC7a Gramophone Motors, with pick-ups complete, 200-250v., 12in. turntable and unit plate, auto. stop, speed regulator, new; 3/2/6 each.

SPEAKERS, pairs, brand new, elliptical cone speakers, made by first class firm, quality of reproduction outstanding, push-pull pentode transformer, fields 325 ohm for smoothing choke, 8,600 ohms bleeder, circuit available, handle 10-15w.; 14/- pair.—Ryalls Radio, see above. [8374]

VAUXHALL UTILITIES, 163a, Strand, W.C.2.—Ask for free list; metal rectifiers, HT10, 10/-; HT9, 9/-.

VAUXHALL—Hivao valves, all types; full range of pick-ups, from 11/-; screened iron-cored 2-gang coils, switch, circuit, 11/3.

VAUXHALL—T.C.C. dry, 8 mfd., 2/6; 600v. aluminium containers; T.C.C. 600v dry, cardboard containers, 8 mfd., 1/9. [8498]

COLLARO A.C./D.C. Record-changers, 200-250, plays eight 10in. or 12in. records, mixed, also incorporates repeater and reactor; limited quantity, £5/5, in sealed cartons.

HENRY'S, 72, Wellington Ave., Stamford Hill, N.15, Stamford Hill 2907. [8216]

MAINS RADIO DEVELOPMENT COMPANY Offer immediate delivery, carriage paid; call mornings, telephone Tudor 4046; stamp for list 227; Transatlantic all-wave tuning packs now available from stock, stamp for details.

DUBILIER Mica Tag Condensers, 0.0005, 0.0001, 0.0002, 0.0003, 0.0005 mfd.; 3d., 2/6 dozen.

AMAZING Resistor Bargain, N.S.F. 1/2, 1 and 2 watt, new, marked, colour coded resistors, 20 different useful sizes in parcel; 50 for 2/6 only.

CLIX Unused Chassis V-holders, 5-pin, 7-pin, 3d. each; all American sizes, 6d. each; best sleeving, 1 1/2 yd. T.C.C. metal can 8 mfd., 600v. dry electrolytics, 2/3.

TUBULAR Condensers, 400 volt working, wire ends. T best make, 0.0001-0.05 mfd., 4d.; 0.1 mfd., 4d.; 0.25, 0.5 mfd., 6d.

CENTRALAB Latest Potentiometers, long standard spindle, unused, all sizes, 5,000 ohms, 2 megohm., 2/-; with mains switch, 2/3.

POLAR Midget Latest Three-gang Condensers, screened, trimmers, 1/4in. spindle, 0.0005 mfd., 110 k/c tracker, unused; 2/6.

ERIE One Watt, colour coded, unused resistors, any 1/2 size, 50 ohms to 5 megohms, your selection, 3d., 2/6 dozen; two watt, 6d.

MAINS RADIO DEVELOPMENT COMPANY, 4-6, Muswell Hill Rd., London, N.6. Tudor 4046. [8457]

Wanted

WANTED, surplus electrical goods.—Description, quantity and price to Box 9866, c/o The Wireless World. [8497]

REPAIRS AND SERVICE

"SERVICE With a Smile."

AMERICAN Valves, spares, linecords, rewinds; repairers of all types of American and British receivers.—F.R.I., Ltd., 22, Howland St., W.1. Museum 5675. [0434]

LOUD-SPEAKER Repairs, British, American, any make, 24-hours service; moderate prices.—Sinclair Speakers, Alma Grove, Copenhagen St., N.1. [0590]

GUARANTEED Repairs Any Transformers, choke, motor armature, converter, dynamo, etc.; keenest prices, immediate quotation, prompt, dependable service.—See below.

L.T.P. (LONDON TRANSFORMER PRODUCTS, Ltd.), Willesden, N.W.10. Willesden 6486 (3 lines). [6892]

MAINS Transformer Service. Repairs, rewinds, or construction to specification of any type, competitive prices and prompt service.—Sturdy Electric Co., Dip-ton, Newcastle-on-Tyne. [0516]

METROPOLITAN RADIO SERVICE—Guaranteed repairs to American and British receivers; American valves, service parts and rewinds; trade supplied.—1021, Finchley Rd., N.W.1. Speedwell 3000. [0435]

REPAIRS to Moving Coil Speakers a Speciality; cones and coils fitted, fields altered; prices, including eliminators, quoted; loud speakers, 4/-; L.F. and output transformers, 4/-, post free; guaranteed satisfaction; trade invited, estimates free; prompt service.—Loud-Speaker Repair Works, (5, Balham Grove, London. Baitersea 1321. [0394]

SITUATIONS VACANT

METROPOLITAN Police.

APPLICATIONS are invited from Assistant Electricians for the installation of wireless apparatus. Commencing salary £3/10 per week.

APPLICATIONS should Possess a Good General Knowledge of Wireless Transmitters, receivers and servicing, and Morse operation at a minimum speed of 20 words per minute is essential. A knowledge of ultra-short wave working will be an advantage. Successful applicants will be engaged for four months, with prospects of continued employment.

APPLICATION Forms May be Obtained From:—

THE Engineer's General Office, New Scotland Yard, London, S.W.1, and should be completed and returned not later than the 12th June. [8516]

VACANCY for Apprentices in Radio Manufacturer's Organisation, constructing transmitters and receivers for Government Departments; works situated in Surrey.—Write Box 9867, c/o The Wireless World. [8501]

**BETTER
RECEPTION
begins with
the aerial**

A set can't give its best on an inefficient aerial. Sensitivity, selectivity, long range, high signal-to-noise ratio . . . all depend on the signals received from the aerial. Unless these are picked up outside the interference-field surrounding almost every house, and protected as they pass down to the receiver, performance is bound to suffer.

**CONQUER
INTERFERENCE
under Money-back
GUARANTEE**

The Belling-Lee "SKYROD" Aerial System makes first-class reception possible even under most difficult conditions. Signals are received 25ft. above the roof, and interference—no matter how bad—cannot pierce the special shielded down-lead employed. 'SKYROD' greatly improves range and volume and protects your listening from the effects of neon signs, power cables, domestic appliances, etc. It costs you nothing to prove this remarkable aerial system with your own set. If the Belling-Lee 'SKYROD' System fails to live up to claims in any way your money will be returned in full.

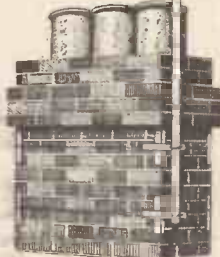

In four mountings, from
£3-19-6 to £6-7-0
H.P. Terms from
1/3 weekly.
Prices do not apply to Eire.

The BELLING-LEE
SKYROD
AERIAL SYSTEM

Belling & Lee Ltd., Cambridge Arterial Road, Enfield, Middlesex.

PREMIER

★ **RADIO** ★

CLASS 'B' KIT, comprising Premier Heavy Duty Class 'B' Driver Transformer, 2 volt Class 'B' Valve, 7 pin Valve Holder and Circuit, 10/- complete.

PREMIER MOVING COIL METERS
Guaranteed Accuracy within ± 2 per cent.
Model No. 21. Model No. 311.

3in. square case.	3 1/2in. diameter round case.
0-1 m/A. ... 18/6	0-1 m/A. ... 22/6
0-10 m/A. ... 17/6	0-10 m/A. ... 20/-
0-50 m/A. ... 17/6	0-50 m/A. ... 20/-
0-100 m/A. ... 17/6	0-100 m/A. ... 20/-
0-250 m/A. ... 17/6	0-250 m/A. ... 20/-

Model 311. 0-1 m/A. movement, with calibrated scale, volts-ohms-m/A., 25/-.

VOLTAGE MULTIPLIER RESISTANCES. Guaranteed accuracy ± 2 per cent. All standard ranges, 1/3 each. **TAPPED SHUNT** to provide readings of 5 m/A., 25 m/A., 250 m/A., and 1,000 m/A., 5/6.

MORSE SETS. ALL METAL, with enclosed Battery. Will buzz, tap or flash, 3/8, complete.

ALL-WAVE AERIAL KIT, including Matching Transformer, Insulators and Weather-proof Wire. Ideal for 2.5-2,000 metres. 10/- complete. Doublet Aerial Kit, Best Short-Wave Aerial, 10/- complete.

PREMIER SHORT-WAVE KITS

Complete to the last detail including all Valves and coils, as well as theoretical and wiring diagrams and lucid instructions for building and working. Each kit is supplied with a steel Chassis and Panel and uses plug-in coils to tune from 13 to 170 metres.

- 1 Valve Short-Wave Receiver or Adapter Kit ... 17/6
- 1 Valve Short-Wave Superhet Converter Kit ... 20/-
- 1 Valve Short-Wave A.C. Superhet Converter Kit ... 22/6
- 2 Valve Short-Wave Receiver Kit ... 25/-
- 3 Valve Short-Wave Screen Grid and Pentode Kit 58/6

PREMIER 3-BAND S.W. KITS

11-86 metres without coil changing. Complete Kits of Parts with Valves and Circuits. One Valver, 12/6; Two Valver, 19/6.

PREMIER U.S.A. QUARTZ TRANSMITTING CRYSTALS 7 mc. Band, 10/- each, with Calibration Certificate Enclosed holder and Base, 3/-.

PREMIER SHORT-WAVE COILS, 4- and 6-pin types, 13-26, 22-47, 41-94, 78-170 metres, 1/9 each, with circuit Special set of S.W. Coils, 14-150 metres, 4/- set, with circuit. Premier 3-band S.W. coil, 11-25, 19-43, 38-86 metres. Suitable any type circuit, 2/6.

UTILITY Micro Cursor Dials, Direct and 100.1 Ratios, 3/9. **PREMIER** Short-Wave Condensers, all-brass construction, with Trolital insulation. 15 mmf., 1/6; 25 mmf., 1/7; 40 mmf., 1/9; 100 mmf., 2/-; 100 mmf., 2/3; 250 mmf., 2/6.

TROLITAL DOUBLE SPACED TRANSMITTING CONDENSERS. 15 mmf., 2/9; 40 mmf., 3/8; 100 mmf., 4/-; 160 mmf., 4/6.

NEW TROLITAL SPLIT STATOR CONDENSERS. 50 x 50 mmf., 10/6.

COIL FORMERS, 4- or 6-pin low-loss, 1/- each. **AMERICAN VALVES**. We hold the largest stocks of U.S.A. tubes in this country and are sole British Distributors for TRIAD High-grade American Valves. All types in stock. Standard types, 5/6 each. All the new Octal Base tubes at 6/6 each, 210 and 250, 8/6 each.

EUROPA MAINS VALVES, 4 v. A.C. Types, A.C./H.L. A.C./L., A.C./S.G., A.C./V.M.S.G., A.C./H.P., A.C./V.H.P., A.C./P., and 1 watt D.H. Pentodes, all 4/6 each. A.C./Pens., I.J., 5/6; A.C./P.X.4, 6/6; Oct. Freq. Changers, 3/8; Double Diode Triodes, 7/8; Triode H. ex. Freq. Ch., 3/6; Tri. Grid Pen., 10/6; 33-watt D.H. Triode, 7/6. 350 v. and 500 v. F.W. Rect., 5/6. 13 v. 2 amps. Gen. Purpose Triodes, 5/6; H.F. Pens. and Var.-Mu. H.F. Pens., Double Diode Triodes, Oct. Freq. Changers, 7/6 each. Full-wave and half-wave Rectifiers, 5/9 each.

MATCHMAKER UNIVERSAL MODULATION TRANSFORMERS

Will match any modulator to any R.F. load. 50 watts, 17/6; 150 watts, 29/6; 300 watts, 49/6.

MATCHMAKER UNIVERSAL OUTPUT TRANSFORMERS. Will match any output valves to any speaker impedance. 11 ratios from 13: 1 to 80: 1. 5-7 watts, 13/6; 10-15 watts, 17/6; 20-30 watts, 29/6. Send for full details.

PREMIER AC/DC MOVING IRON METERS. 2 1/2in. diam. Flush Mounting. All ranges. 10 m.a., 30 m.a., 50 m.a., 100 m.a., 250 m.a., 500 m.a., 5/9 each.

AMMETERS. 1, 3, 5, 10 or 30 amps., 5/9 each.

PREMIER 1939 HIGH FIDELITY AMPLIFIERS A New Complete Range of 7 High Fidelity P.A. Amplifier for A.C. or A.C./D.C. Mains operation. Completely

	Kit of Parts with Valves. Wired and Tested.
3-watt A.C. Amplifier ...	£2 0 0
3-watt A.C./D.C. " ...	£2 15 0
6-watt A.C. " ...	£5 5 0
8-10-watt A.C./D.C. " ...	£4 10 0
15-watt A.C. " ...	£5 15 0

Black Crackle Steel Cabinet 15/- extra.
Orders 5/- and over sent Post Free. Under 5/- please add 6d. postage.

Have you had our 1939 Catalogue, Handbook and Valve Manual? 90 pages of Radio Bargains and Interesting Data. Price 6d.

ALL POST ORDERS TO: Jubilee Works, 167, Lower Clapton Road, London, E.5. Amherst 4723
CALLERS TO: Jubilee Works, or our NEW PREMISES
169, FLEET STREET, E.C.4. Central 2833
or 50, High Street, Clapham, S.W.A. Macaulay 2331.

ELECTRADIX

TWO CLEAR SCALES with MIRROR are on the DIX-ONEMETER

The Dix-Onemeter with only 6 Terminals, but 50 Ranges, is a valuable instrument for laboratory work. It is of portable size to go in the pocket, but big enough to cover the whole range of D.C. electrical measurements, 50 microamps. to 20 amps. and 20 millivolts to 2,000 volts.

55/- ONLY

Multipliers from 6/6 each.

DIX-MIPANTA TEST METER

This is a wonderfully versatile, high-grade moving iron multi-range meter for service on A.C.D.C. jobs. No projecting terminals. THREE ranges of volts: 0-7.5, 0-150, 0-300. Used for MILLI-AMPS. reads 0-12 1/2



THE DIX-ONEMETER, 55/-

m.a. and 0-75 m.a. In black bakelite case. Only 2 1/2 in. by 2 1/2 in. EVERSHED MEGGERS.—Direct Reading ohms to megohms. Long scale dial, from 24/10/-.

MILLIAMMETERS.—8 m.a. back of panel illuminated milliammeters. Skeleton type, 970 ohms D.C. with plain scale and lin. needle with mica panel, back lamp and bracket.

HILGER REFRACTOMETER.—Immersion Type for refractive index of liquids. Cost £25. New condition. £3/10/-

VALVE BARGAINS for Transmitters. Marconi 35-watt 10-metre DETI New 27 Valves for 15/-

POCKET HEADPHONES, W.D., all leather headband, strap and cords, 2/6 pair.

TELEPRINTER TELEGRAPH.—G.P.O. Model for Typewriter transmission. Electrically operated, in new condition, beautiful work. Cost £50. Sale £24.

PARCELS of useful oddments for the Experimenter who wants a junk-box of Coils, Magnets, Wire, Chokes, Condenser, Switches, etc., mostly ex-W.D. parts worth a lot more than 10 lbs. 6/-, or 7 lbs. for 4/-, post free.

Dynamos, Alternators, Rotaries and Motors all Sizes. Send for Radio-Electrical-Scientific Illus. List "W," Free.

ELECTRADIX RADIOS, 218, UPPER THAMES STREET, LONDON, E.C.4.

Telephone: Central 4611

THE POLYTECHNIC, REGENT STREET, LONDON, W.1.

A Special Course of Four Lectures on Modern Television

will be given by H. J. BARTON - CHAPPLE, Wh.Sc., B.Sc., A.O.G.I., A.M.I.E.E., on Thursday Evenings, 7.30—9, beginning 8th June, 1939.

The lectures will be illustrated by experiments, lantern slides, and demonstrations on modern television receiving equipment, including the reception of the B.B.C. Television Service at 9 p.m., after each lecture.

FEE FOR THE COURSE, 6/-.

Syllabus on application to the Director of Education.

The Autocar EVERY FRIDAY FOURPENCE w.w.16.

SITUATIONS VACANT

AIR MINISTRY. AERONAUTICAL Inspection Directorate.

VACANCIES Exist for Unestablished Appointments as Examiners in the W.T. and Instrument Branches. Qualifications:—

APPLICANTS for Vacancies in Instrument Branch must have Good General Education, theoretical knowledge of physics and training in light engineering or instrument making.

APPLICANTS for Vacancies in W.T. Branch having the Following Qualifications will receive Preference: Good general education, sound technical knowledge of high-frequency engineering equal to City and Guilds Final Examination in Radio Communications.

SUCCESSFUL Candidates will be given a Period of Training in Inspection, as applied to these subjects, not exceeding three months.

DURING Training, candidates will be regarded as on probation and paid at the rate of £184 a year; on satisfactory completion of the training course they will be appointed as Examiner and paid at £246 a year.

SUBSISTENCE Allowance, at the rate of £1/5 weekly, is payable whilst under training to married men (and others with certain dependents) who normally reside outside the training centre.

SALARIES are paid Monthly in Arrear.

CANDIDATES Must be Prepared to Serve in Any Part of the United Kingdom, and be willing to fly as observers in connection with their duties.

NORMAL Age Limits, 21-50 years; candidates between 50-55 years will be considered if they have had previous inspection experience.

CANDIDATES who, on interview, fail to qualify for the Examiner Grade may be considered for:—

ASSISTANT Examiner.—Salary scale, £184-£210-£246.

ASSISTANT Examiners do not undergo Training, but are appointed direct to an A.I.D. station; they may later become eligible for promotion to Examiner on attaining the requisite standard of efficiency.

APPLICATION Must Be Made on Form 786, copies of which can be obtained on application (by post-card only), to:—

THE UNDER-SECRETARY OF STATE, Air Ministry (I.C.S./Rec.40), Berkeley Sq. House, Berkeley Sq., W.1. [8514]

TELEVISION Designer-engineer: Required for Research Laboratory of Modern and Progressive Firm in West London; must have experience of design and development of radio side of television receivers.—Apply in confidence, with full particulars, to Box 9934, c/o The Wireless World. [8509]

ELECTRIC DRY SHAVERS

REMINGTON, Rand, Shavemaster, Packard and Casco. —Trade enquiries to Leonard Heys, 36, Henry St., Blackpool. [0633]

REPAIRS to All Makes of Electric Shavers, voltages R changed.—Sinclair Speakers, Alma Grove, Copenhagen St., London, N.1. [0634]

MISCELLANEOUS

CHEAP Printing.—1,000 billheads, 3/6; sample free.—Creiteway Press, 18, Buxted, Sussex. [8180]

EVERY Radio Dealer Who is Not a Regular Reader of "The Wireless and Electrical Trader" should send his trade card at once for a specimen copy and full details of the "Trader" Services.

BUSINESSES AND PROPERTY FOR SALE, TO BE LET, OR WANTED

NEED for Radio and Cycle Dealer on Large New Estate. Main road position. Success assured. No premium.—Apply Fairway Homes, Mutton Lane, Potters Bar, Tel.: 931. [8477]

"THE Wireless and Electrical Trader" is an essential part of the equipment of every Wireless Trader; its pages reflect the very latest turn of trade events, and it is read by all the leading dealers and manufacturers, for particulars of businesses offered or wanted.

PATENTS

"PRACTICAL Hints on Patents," free on application.—The Imperial Patent Service, First Avenue House, High Holborn, W.C.1. Preliminary consultation free. [0481]

TUITION

RADIO Training.—P.M.G. exams and I.E.E. Diploma; prospectus free.—Technical College, Hull. [0611]

PRACTICAL Radio and Television Home Study Courses; booklet free.—I.P.E., 3, Shirley Rd., London, W.4. [8506]

MORSE Practice with Expert Quickly Gives You Speed; individual or small classes; stamp details.—Ward, 23, Millman St., W.C.1. [8517]

WIRELESS.—Complete training, Marine, Broadcast and Television. Posts waiting. Mod. fees. Boarders taken. Approved college, prosp.—Dept. W., London Radio College, Grove Park Rd., London, W.4. (Chi. 3244.) [0580]

WIRELESS Careers; increased salaries and pensions make radio a profitable and interesting profession; we train students for all branches and guarantee appointments; Britain's leading Colleges; boarders accepted; write for free prospectus.—Wireless College, Colwyn Bay, or Wireless College, Calmore, Southampton. [8373]

BOOKS, INSTRUCTION, ETC.

CATHODE Ray Tubes.—40 pages of valuable practical data on "How to Use Them" (by J. H. Reynr, B.Sc., A.I.M.E.E.), 30 instructive photographs of waveforms, etc. 1/1 post free from Furzehill Laboratories, Boreham Wood, Herts. [8503]

AMERICAN Valve Data.—The new 200-page Raytheon Valve Data Book gives full characteristics and applications of all types of American valves; invaluable to all servicemen; post free, 2/3; abroad, 3/-. Leonard Heys, 36, Henry St., Blackpool. [0594]

THE INSTITUTE OF WIRELESS TECHNOLOGY (Founded in 1925. Incorporated).

PROFESSIONAL MEMBERSHIP

The advantages of professional membership are open to all qualified wireless engineers.

Full information, with syllabus, may be obtained from the Secretary, Institute of Wireless Technology, 4, Vernon Place, Southampton Row, London, W.C.1. Phone: Holborn 4879.

Pamphonic AMPLIFIERS Pamphonic Reproducers Ltd. (Associated with PYE Ltd.) 45, St. Pancras Way, London, N.W.1. Phone: EUSton 1727.

Illustration of a man and woman at a picnic. Text: At the picnic, our portable set Quite early, stopped working, and yet We missed none of the fun As we might well have done If we hadn't had FLUXITE, you bet!

See that FLUXITE is always by you—in the house —garage—workshop—wherever speedy soldering is needed. Used for 30 years in Government works and by leading engineers and manufacturers. Of Ironmongers—in tins, 4d., 8d., 1/4 and 2/8. Ask to see the FLUXITE SMALL-SPACE SOLDERING SET—compact but substantial—Complete with full instructions, 7/6. Write for Free Book on the art of "SOFT" SOLDERING—and ask for leaflet on CASE-HARDENING STEEL and TEMPERING TOOLS with FLUXITE.

TO CYCLISTS! Your wheels will NOT keep round and true unless the spokes are tied with fine wire at the crossings AND SOLDERED. This makes a much stronger wheel. It's simple—with FLUXITE—but IMPORTANT

THE FLUXITE GUN

is always ready to put Fluxite on the soldering job instantly. A little pressure places the right quantity on the right spot and one charging lasts for ages. Price 1/6 or filled 2/3

ALL MECHANICS WILL HAVE FLUXITE IT SIMPLIFIES ALL SOLDERING FLUXITE, LTD., Dept. W.W., DRAGON WORKS, BERMONDSEY ST. S.E.1.

FOURTH EDITION

Revised and Enlarged with 50 Additional Pages

WIRELESS SERVICING MANUAL

By **W. T. COCKING**
(of "The Wireless World")

The most complete book of reference of its kind. A reliable practical guide for amateur and professional

The present Edition of the "Wireless Servicing Manual" brings the material of the book right up to date and includes an additional chapter on television receivers which is practically the only source of servicing information available on this subject.

Testing apparatus is fully dealt with and the methods of locating and curing faults in receiving equipment are explained.

Ganging, Automatic Volume Control, Instability, Distortion, Mains Hum, Whistles, Local Interference and Aerials, are all separately treated.

The reference material, including base-connections for British, Continental and American Valves, and the various colour codes for components, has been extended and revised.

BOUND IN CLOTH BOARDS

SIZE 7½ ins. x 5 ins.

288 Pages

5/- net. By post 5/5

Issued in conjunction with "THE WIRELESS WORLD" and Published by the Proprietors:—

ILIFFE & SONS LTD., DORSET HOUSE, STAMFORD STREET, LONDON, S.E.1

W.W.20.

The ELECTRICAL REVIEW

The Complete Technical Journal

Practical articles on all aspects of electricity supply and utilisation—industrial, commercial and domestic. Latest news of the electrical industry and developments. Advertisement pages form a comprehensive buyers' guide.

Contents of June 2nd issue:—

THE I.M.E.A. CONVENTION VENUE

A guide to places of electrical and general interest in and around Harrogate, with a description of the electricity undertaking.

ELECTRICAL ASSOCIATION for WOMEN

The fourteenth of a series of articles on the objects and activities of prominent organisations in the electrical industry.

THE PARIS FAIR

Details of some new electrical devices exhibited.

RESIDENTIAL DISTRIBUTION

A reorganisation scheme at Thornton Cleveleys.

EVERY FRIDAY 6d.

Subscriptions: United Kingdom £1 14 8
Canada £1 12 6 Other Countries
£2 1 6 per annum, post free.

ELECTRICAL REVIEW LTD.

Dorset House, Stamford Street, London, S.E.1

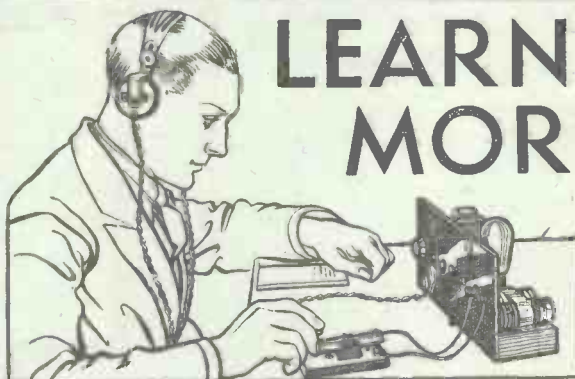

LEARNING MORSE

AN EASY METHOD OF MASTERING THE INTERNATIONAL SIGNAL CODE

Published from the Offices of

The **Wireless World**

ILIFFE & SONS LTD., Dorset House, Stamford St., London, S.E.1

6^D NET
BY POST 7d.
W.W.94

THE WIRELESS ENGINEER

The Journal for Professional Engineers and Advanced Wireless Experimenters

Monthly
2/6 net.

Annual Subscription
32/- post free.

ILIFFE & SONS LTD., Dorset House, Stamford St., London, S.E.1

Mention of "The Wireless World," when writing to advertisers, will ensure prompt attention.

The Rev.
W. H.
ELLIOTT

has one and a half million members
in his League of Prayer. Read
his intimate and inspiring message
which appears exclusively every
week in the **SUNDAY GRAPHIC.**

He writes for you in the

SUNDAY
GRAPHIC

Best for News, Views and Pictures



The Wireless World

6^D

THE PRACTICAL RADIO & TELEVISION JOURNAL

Thursday, June 8th, 1939

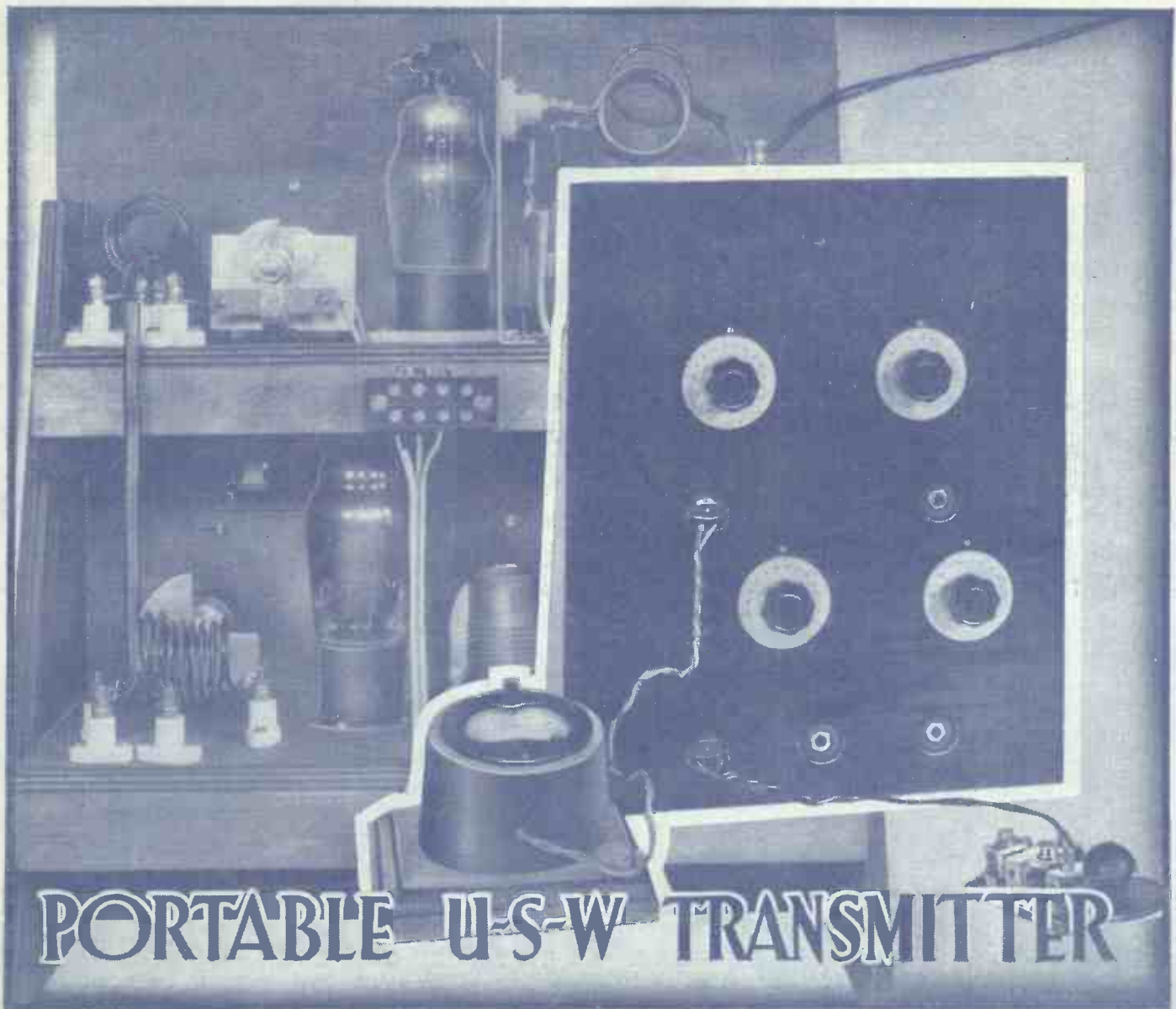

PORTABLE U.S.-W TRANSMITTER

GE CALLOY RADIO CORES.

GREATER MAGNIFICATION. ROBUST CONSTRUCTION.

HIGHER SELECTIVITY. SIMPLE ADJUSTMENT.

REDUCED COSTS.

SMALL SIZE.

Gecalloy Radio Cores are made from a patented composite magnetic powder, and are manufactured exclusively by Salford Electrical Instruments Ltd.

The permeability of the material gives maximum performance and minimum loss over the radio frequency wave-band. Coils with cores made from this material have very good properties for use in tuning coils and filters for broadcast and intermediate frequencies.

The quality or "Q" factor of such coils is approximately twice as good as the average shielded air coil hitherto used, and, in addition, appreciable savings in cost can be made by the use of these cores.

For general radio purposes the permeability of Gecalloy core material is 12.0. The variation of permeability with current is negligible for all cores, and cannot be detected in ordinary circumstances. The variation of permeability with frequency is also negligible, but the self-capacitance of the coil must be kept sufficiently low to enable this to be achieved, since the effective inductance variation is dependent on these two factors.

Our booklet S.37 gives details of the types available and will be sent on request.

SALFORD ELECTRICAL INSTRUMENTS LTD.

PEEL WORKS, SALFORD, 3.

Telephones: BLAckfriars 8888 (3 lines)

Telegrams and Cables: "SPARKLESS, MANCHESTER"

PROPRIETORS: THE GENERAL ELECTRIC Co. Ltd., OF ENGLAND.

Mention of "The Wireless World," when writing to advertisers, will ensure prompt attention.

The Wireless World

THE PRACTICAL RADIO JOURNAL
29th Year of Publication

No. 1032.

THURSDAY, JUNE 8TH, 1939.

Vol. XLIV. No. 23.

Proprietors: ILIFFE & SONS LTD.

Editor:
HUGH S. POCOCK.

Editorial,
Advertising and Publishing Offices:
DORSET HOUSE, STAMFORD STREET,
LONDON, S.E.1.

Telephone: Waterloo 3333 (50 lines).
Telegrams: "Ethaworld, Sedist, London."

COVENTRY: 8-10, Corporation Street.
Telegrams: Telephone:
"Autocar, Coventry." 5210 Coventry.

BIRMINGHAM:
Guildhall Buildings, Navigation Street, 2.
Telegrams: Telephone:
"Autopress, Birmingham." 2971 Midland (5 lines).

MANCHESTER: 260, Deansgate, 3.
Telegrams: Telephone:
"Iliffe, Manchester." Blackfriars 4412 (4 lines).

GLASGOW: 26B, Renfield Street, C.2.
Telegrams: "Iliffe, Glasgow." Telephone: Central 4857.

PUBLISHED WEEKLY. ENTERED AS SECOND CLASS MATTER AT NEW YORK, N.Y.

Subscription Rates:
Home and Canada, £1 10s. 4d.; other countries, £1 12s. 6d. per annum.

As many of the circuits and apparatus described in these pages are covered by patents, readers are advised, before making use of them, to satisfy themselves that they would not be infringing patents.

CONTENTS

	Page
Editorial Comment	525
Five-Metre Portable Transmitter ..	526
Problem Corner	529
Rooms, Booms and Decibels	530
Tone-control Systems	532
Longer Life for Dial Lamps	537
Television Programmes	537
Unbiased	538
News of the Week	539
Wireless in the Services	541
$\lambda = 1,885 \sqrt{LC}$	543
News from the Clubs	544
Automatic Frequency Control	545
Random Radiations	546
Letters to the Editor	547
Five-metre DX	547
Recent Inventions	548

EDITORIAL COMMENT

Inadequate Receivers

No Claim for Protection

THAT no wireless user is entitled to complain of interference from unwanted stations unless his receiver embodies all the anti-interference measures that can reasonably be expected in the light of existing knowledge is surely axiomatic. In the absence of such a principle wireless development might well be hampered by any vocal section of users that chooses to adopt a dog-in-the-manger attitude by clamouring for protection against interference, though at the same time failing to use proper apparatus whereby that interference might be avoided.

Of course, the transmitting station is bound by a similar obligation to work within the terms of its licence: those responsible for the station should even go farther than the strict letter of the law requires by operating the transmitter in such a way as to avoid causing unnecessary interference. Out-of-date gear should be replaced even before it becomes compulsory to do so. The complaints, now fortunately becoming rare, of broadcast listeners regarding interference from spark transmitters were, for instance, entirely justified, as that method of transmission has long been obsolete except for a few special purposes.

A case of unjustified demands for protection against interference comes from America, and the circumstances are such as to merit the consideration of those concerned with the design and production of broadcast receivers in this country. It appears that, due to the growing tendency to omit adequate preselection from American broadcast sets, listeners are suffering from image interference from amateur transmitters operating on various bands. Receivers

are getting worse instead of better in this respect and the American Radio Relay League, the amateur transmitters' association, fears now that its members' privileges may be restricted. *QST*, the official organ of the League, records the opinion that "the 1939 crop of receivers is the most generally unsatisfactory that has been produced in many a year." The public has been educated to demand such external refinements as push-button tuning and remote control, and, as price competition is keen, there is little money left for the fundamentally important parts of the receiver.

Preselection has apparently been the first thing to go, with the result that the receivers, though not lacking in adjacent-channel selectivity (which always impresses a potential buyer) are inferior to earlier models in their ability to discriminate against signals of non-broadcast services.

There is perhaps some excuse for sketchy preselection circuits in the simplest and cheapest kind of broadcast superheterodyne, but we hope that the American example of neglecting this important section of the receiver will not be followed too far in this country.

B.B.C. - Baiting

New Style

THE lay Press has recently published letters from many parts of the world on the alleged difficulty of receiving B.B.C. programmes abroad. Complaints from Scandinavia have already been refuted by our local correspondent, and, judging by the obvious lack of knowledge disclosed in most of the other letters, the opinions expressed are equally to be suspected. Their publication seems to have served no useful purpose.

Five-Metre Portable

A COMPACT CRYSTAL-CONTROLLED SET FOR FIELD DAY USE

THERE has been a tendency in the past to think too little about the design of a portable transmitter for use on the ultra-high frequencies. When asked what one proposed to make, the customary answer was: "Oh, I expect it will be something simple—just a couple of valves as a push-pull oscillator," or "An XYZ valve, as So-and-so told me it worked well in the last set he used." During the past few months, however, many amateurs have begun to realise that these obsolete types of five-metre transmitters will have to give place to something a little more in keeping with present-day ultra-high-frequency technique and that a serious effort must be made to evolve a transmitter that includes a satisfactory means for stabilising the frequency. This is all the more necessary since it is almost certain that CW transmission will be employed to a much larger extent than hitherto, for it must be remembered that this method of signalling greatly increases the range of any transmitter.

The design of a crystal-controlled five-metre portable is an interesting problem, as the HT consumption must be kept down to the absolute minimum and a high degree of efficiency maintained throughout.

As economy is essential, the equipment

illustrated here should meet the requirements of those who are without the convenience of an electric supply. The fixed station is not quite so restricted in its source of operating voltages, since a small generating plant could be used. When the transmitter is required to be sufficiently compact for easy transportation from one position to another the HT supply becomes an important factor in its design.

A truly portable set would of necessity have to be restricted to quite low power operation, but as this type of set is rarely needed for amateur activities a slightly more ambitious design was visualised, it being assumed that the mobility of the equipment need not extend beyond the ability to transport it conveniently from one place to another.

Economy was broadly interpreted, and so the basic frequency was taken as being of the order of 7.2 Mc/s, as quartz crystals for this frequency are readily obtainable.

Among the first arrangements tried was a two-valve transmitter in which the first valve, a pentode, was operated as a harmonic generator, having its anode circuit tuned to the fourth harmonic of the crystal. This gave an RF output at approximately 29 Mc/s, and it was proposed to double the frequency again in the following, which would also be the

final, stage and thus feed the 58 Mc/s output direct to the aerial.

Though this idea seemed quite promising at the outset, it did not appear so satisfactory when examined in a more critical mood, owing to the small amount of RF power generated at 58 Mc/s compared with the DC power consumed by the set.

The first valve required about 35 mA at 250 volts, while the second and final stage demanded 65 mA, and then gave only about two watts output at the working frequency.

HT Consumption

The reason for the very low efficiency was traced to the small amount of driving power available for the final frequency doubler. Quite good results with this type of set have been obtained by some amateurs, but usually they have been impossible to repeat, as the success of the original set depended solely on the particular valves that were used.

So far as the experimental layout mentioned here is concerned, the input required exceeded the amount one had in mind, which was about 70 mA at 250 volts. Limiting the consumption to 70 mA broadens the scope of the set, as either HT batteries, small LT-operated generators, or vibrator HT supply units can be employed.

Since no worth-while improvement, either in reduction in input power or in

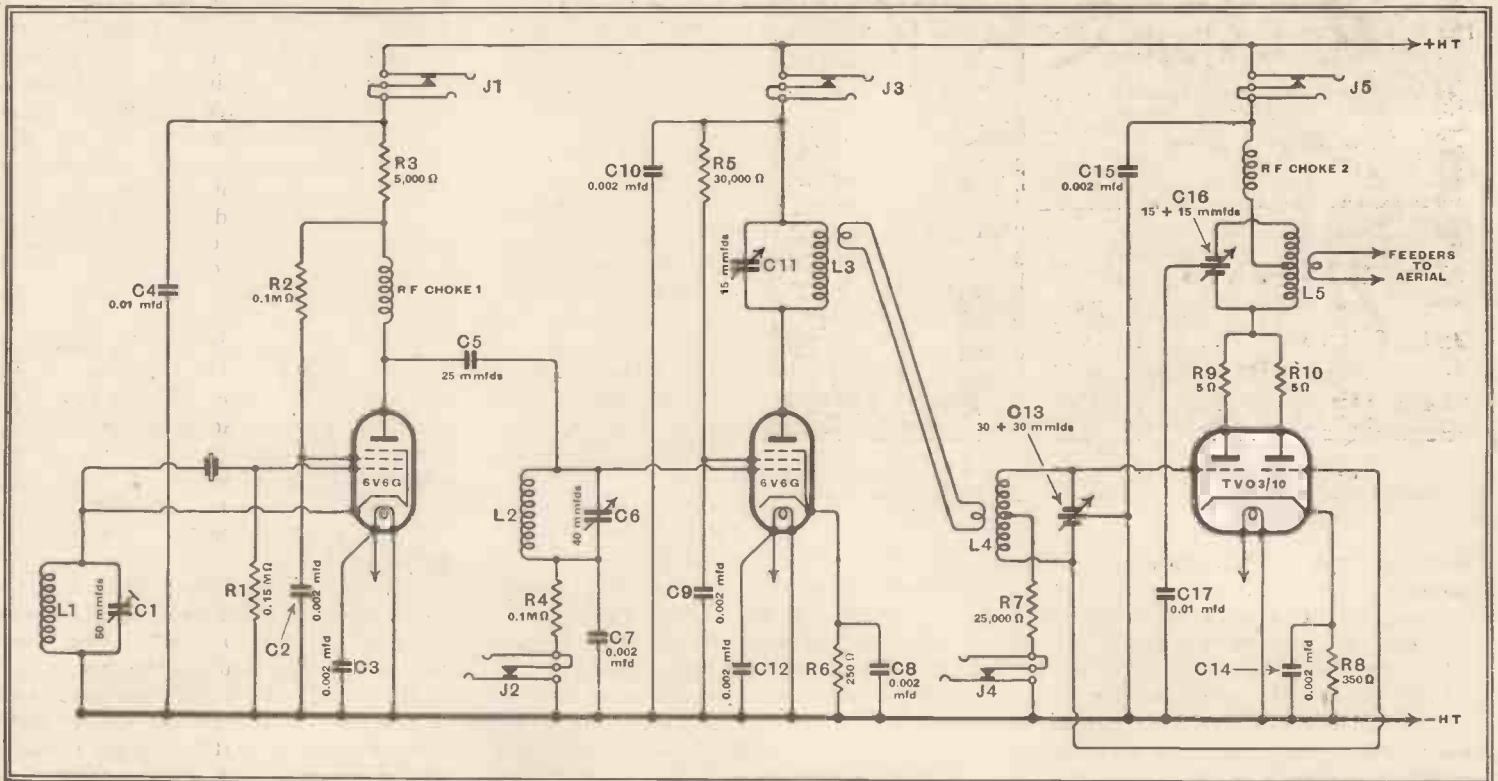

Fig. 1.—Theoretical circuit of the portable five-metre transmitter. Note the inclusion of jacks in all anode and grid circuits for anode and grid current measurements.

Transmitter

By
H. B. DENT (G2MC)

*M*ANY opportunities can be found during the summer to operate a portable five-metre transmitter under ideal conditions. The set described in this article contains three valves, one of which is a crystal controlled oscillator, yet it is economical in its consumption. Though intended for CW transmission, modulation can easily be applied either for ICW or for telephony.

RF output, could be made with this arrangement, it was finally abandoned and a three-valve transmitter assembled.

In the new set the RF output from the first stage was at 14.5 Mc/s, and the second and third valves were operated as frequency doublers. Valves and operating conditions were chosen to limit the HT consumption to 30 mA for the first two, and 40 mA for the final valve, making a total of 70 mA.

By using a Tungram 6V6G valve in the first and second stages, and with the first arranged as a triode oscillator, frequency doubling to 14.5 Mc/s, an adequate RF output could be obtained for an HT consumption of about 10 mA only.

The second valve gave about 3 watts output on 29 Mc/s for an HT input of

been tried it was decided to employ a Mullard TV03-10 as a push-pull frequency doubler for the final stage; the circuit of the transmitter thus evolved is shown in Fig. 1. From this it will be seen that the first and second valves are capacity-coupled, but that between the second and third link coupling is employed.

It was necessary to avoid any direct form of coupling in this case, as the input to the last valve has to be arranged in push-pull. Another factor that weighed in favour of link coupling was that the stray capacities across both L₃ and L₄ would be materially reduced, thereby enabling a higher L/C ratio to be employed in their respective circuits.

Since the frequency has been multiplied up to 29 Mc/s at this point in the transmitter unduly high stray capacities must be avoided so far as possible. Also, with link coupling the set can be split into two units, which fitted in very nicely with the particular form of construction shown in the illustrations. Built in this way, the transmitter can be fitted in a cabinet measuring 16in. high, 13in. wide, and 7in. deep. Cathode resistances R₆ and R₈ provide a minimum grid bias for the second and third valves, but when an RF input is applied to these stages additional grid bias, dependent upon the magnitude of the input voltages, is obtained from resistances R₄ and R₇. These bias voltages are generated by the rectified grid current flowing through the resistances.

In the case of the second stage there is just under 1 mA of grid current, which will produce a potential difference of about 100 volts across R₄. As there is 5 mA of grid current in the third stage, the 25,000-ohm resistance R₇ supplied an additional bias of about -160 volts.

There was no need to include a cathode

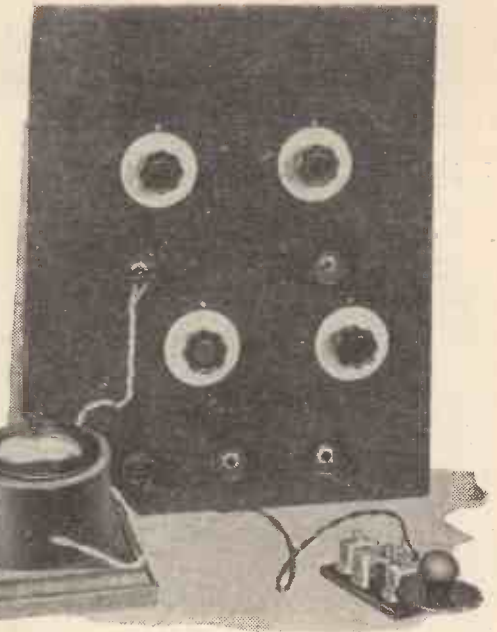

bias resistance for the oscillator, as the low-screen voltage prevents an excessive rise in anode current even if the valve stops oscillating, when oscillating grid bias is obtained from R₁. For the same reason it is quite unnecessary to fit an indicator lamp in series with the crystal, as the crystal current is only just sufficient to produce a very faint glow.

Crystal Frequency

The fundamental frequency of the crystal should be chosen to place the operating frequency between 58.5 and 60 Mc/s—that is to say, one ground for a frequency between 7,310 and 7,495 kc/s; the one supplied by the Quartz Crystal Co. for this set oscillated on 7,353 kc/s, which gave a working frequency of 58,824 kc/s (58.824 Mc/s).

Coil L₁ is wound on a 1½in. length of ¾in. diameter Paxolin tube, and has 24 turns of No. 20 SWG enamelled copper wire. It is a close-wound coil and occupies just under one inch. A Polar air-dielectric trimmer of 50 m-mfds. maximum capacity is used for C₁, and between one-half and two-thirds of the full capacity is needed for correct operation of this stage. Both L₁ and C₁ are mounted below the chassis.

The position of L₂ and C₆ may seem a little unusual, as it is customary to connect this circuit direct to the anode of the oscillator valve. Actually, all that has been done in this case is to transpose L₂ C₆ and the RF choke, which is generally used as the grid impedance for the following stage, when capacity coupling is employed.

Coil L₂ is wound on a 1¾in. length of 1in. diameter Paxolin tube, and has twelve turns of No. 20 SWG DSC wire. Enamelled wire would serve just as well, and the only reason DSC was used in this case is that a suitable coil was available. The turns are spaced to occupy a winding length of 1¼in. A more efficient coil could be designed, but this one gave an RF output quite adequate for the purpose.

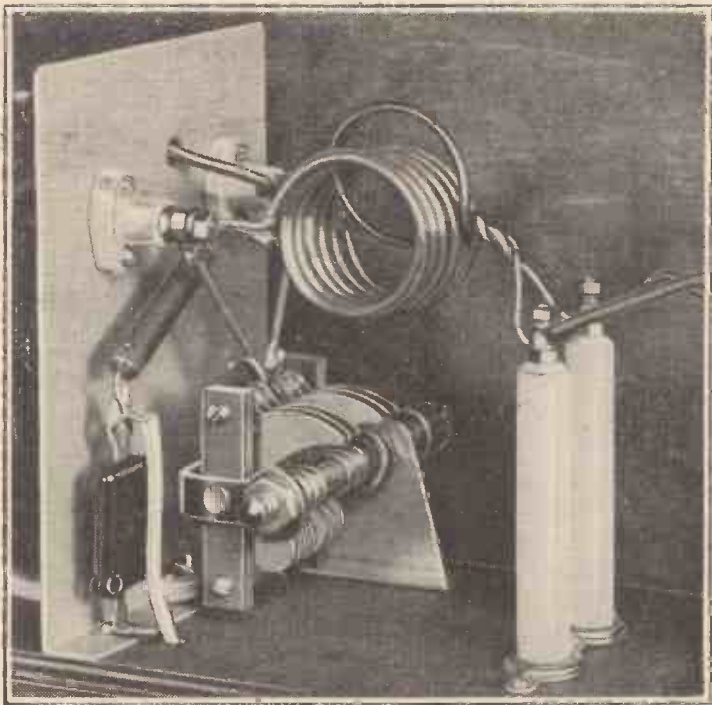

The five-metre output is conveyed to the aerial by a low-impedance feeder terminating in the single-turn coupling coil shown here.

only 20 mA. This certainly seemed promising, for 3 watts at 29 Mc/s should be ample to drive another frequency doubler and achieve a reasonably good RF output at the working frequency, despite the low HT power available.

The main difficulty is, of course, that as the frequency is raised the losses go up, and it is by no means easy to maintain a high order of efficiency.

After many different arrangements had

Five-Metre Portable Transmitter—

It is necessary to pay more attention to the design of the coils L3, L4, and L5, owing to the higher frequencies to which these circuits are tuned. L3 is a self-supporting coil having 9 turns of No. 15 SWG enamelled copper wire with the turns spaced to occupy a length of 1½ in. It is mounted on Eddystone midget stand-off

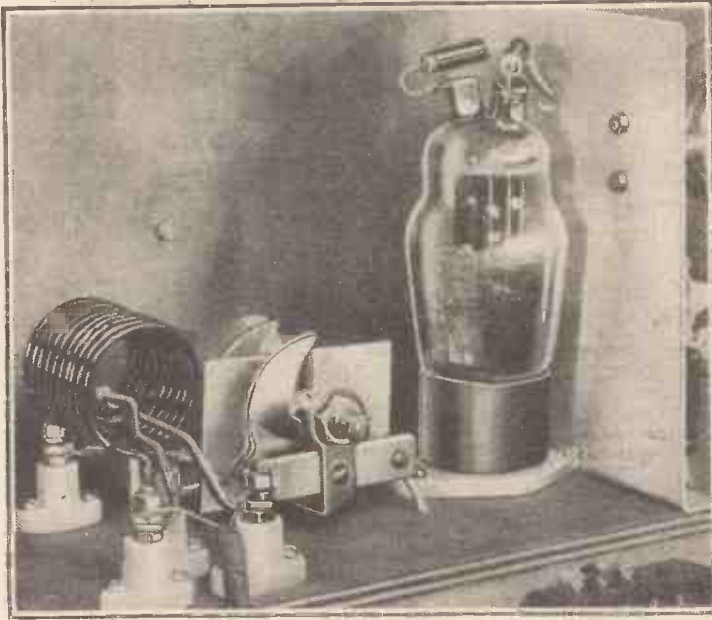

The grid circuit of the final stage is arranged in push-pull using a split-stator condenser. The connections to the link coupling coil can be seen on the left.

insulators and has a mean diameter of 1 inch.

These two stages form one complete unit, and they are assembled on a plywood chassis measuring 12 in. x 6 in. x 1½ in. deep. A metal chassis could be used if preferred.

Mounted above this unit is the final frequency doubling stage, and the layout on this shelf is arranged so that the input circuit is immediately about the output end of the second 6V6G valve. The link coupling coils each have two turns; the one on L3 is at the low potential, or HT positive, end, and the two turns are wound outside the coil with a clearance of ¼ in. all round. As the coupling coil for L4 has to be located in the centre, this being the low potential point so far as RF is concerned, it was more convenient to place it inside L4, as the centre-tap lead comes away from the outside of the coil and passes down through a hole in the chassis to R7. Coil L4 is also a self-supporting one and consists of 10 turns of No. 15 SWG enamelled copper wire with turns spaced to occupy 1½ in., the mean diameter being 1½ in.

Final Stage

A frequency doubling stage of the kind shown must be laid out with some care, as it is most important that the leads from C13 and the two grids be as short as possible. Long leads here, and also to the anode condenser C16, will breed trouble in the form of parasitic oscillation. A split-stator condenser must be used for C13 and C16, and for the former a JB

Twin Midget of 30 m-mfds. per section is fitted. One of the same make is also used for C16, but at our request it was modified by the makers and has double-spaced vanes. There are three moving and three fixed vanes in each section, which gives a capacity of about 15 m-mfds. per section.

This condenser tunes a coil having 6 turns of ½ in. outside diameter copper tube spaced to occupy a length of 1½ in., and the mean diameter is 1½ in. HT is fed to the valve via an ultra-short-wave RF choke connected to the centre turn of the coil.

The chassis for this stage measures 12 in. x 4½ in. x 1½ in., and its top surface is 6 in. above that of the one below.

A word of explanation may not be out of place concerning condenser C17. It is not essential, but it was fitted solely as a precautionary measure, for if the moving vanes of C16 accidentally touch the

fixed ones there will be a short circuit on the HT supply. This condenser merely isolates C16 from the earth line. Should a metal chassis be used C16 must be mounted on an insulated bracket. All condenser spindles are at earth, or virtually at earth, potential so far as RF is concerned, but all the same they are isolated from the dials by short Paxolin rods ¼ in. diameter.

Resistances R9 and R10 are included to suppress parasitic oscillation and they must be joined direct and with quite short leads to the anode clips of the valve.

As will be seen from Fig. 1 and from the illustrations, there are five jacks in the circuit. Three, which in the front illustration can be seen along the bottom of the panel, are for measuring the anode and grid currents of the two 6V6G valves. Looking at the front panel their order from left to right is J1, J2 and J3,

while J4 and J5 are in the centre of the panel and above J3 and J1 respectively.

With all adjustments correctly made and a suitable load coupled to the output valve a milliammeter plugged into J1 should read about 10 mA, in J2 between 0.8 and 1.0 mA, in J3 22 mA, in J4 about 5 mA, and in J5 between 38 and 42 mA, with an HT of about 250 volts.

Milliammeters were not permanently fitted, as it was more convenient to use a multi-range meter, such as an AvoMinor, as the one instrument would serve also for voltage measurements.

Aerial

Finally, means must be provided for feeding the RF output to the aerial, and the system employed for this set was a half-wave dipole with a low-impedance feeder joined to the centre. A single-turn coil coupled to the centre of L5 was accordingly used, and a crude but quite effective variable coupling is arranged by mounting the coil as shown in the illustrations.

The coil, a single turn of No. 18 SWG tinned copper wire encased in insulated sleeving, is inserted between the centre turns of L5 and its position varied to give maximum current in the feeder.

An RF ammeter connected in one of the feeder lines can be used, but a small flash-lamp bulb answers quite well if a suitable meter is not available.

The question of power supply will, for the present, be left in abeyance, but it is hoped to deal with the matter at a later date. Suffice it to say that any form of



Adopting a double-deck form of construction results in a very compact set, yet all parts are quite accessible.

Five-Metre Portable Transmitter— supply at 250 volts capable of delivering 70-75 mA will operate the set.

Likewise the question of modulation for telephonic transmissions is a matter for separate treatment. It requires an amplifier of sufficient overall gain to suit the particular microphone used and it must give at least four watts output.

For CW transmissions a Morse key can be inserted either in J1 or J3; the former is, however, the better position. A simple key filter consisting of a 1 mfd. condenser with a 1,000 ohm resistance in series and joined across the key contacts can be included if interference is experienced from key clicks, but when used as a portable set

LIST OF PARTS

- 1 Twin Midget condenser, 30 m-mfd. each section, **C13** JB
 - 1 Twin Midget Special condenser (double speed vanes), **C16** JB
 - 1 40-m-mfd., condenser, **C6** Premier Tro, 40T
 - 1 15-m-mfd., condenser, **C11** Premier Tro, 15T
 - 2 0.01 mfd., mica condensers, **C4, C17** T.C.C. Type "M"
 - 9 0.002 mfd., mica condensers, **C2, C3, C7, C8, C9, C10, C12, C14, C15** T.C.C. "M"
 - 1 25 m-mfd., ceramic condenser, **C5** T.C.C.
 - 1 150,000 ohms, 1 watt resistance, **R1** Erie
 - 2 100,000 ohms, 2 watts resistances, **R2, R4** Erie
 - 1 30,000 ohms, 2 watts resistance, **R5** Erie
 - 1 25,000 ohms, 2 watts resistance, **R7** Erie
 - 1 5,000 ohms, 2 watts resistance, **R3** Erie
 - 1 350 ohms, 2 watts resistance, **R8** Erie
 - 1 250 ohms, 2 watts resistance, **R6** Erie
 - 2 5 ohms, 1 watt resistances, **R9, R10** Erie
 - 1 Piezo-electric Quartz Crystal frequency between 7,310 and 7,495 kc/s Q.C.C., Type S5 Bulgin J6
 - 5 Closed circuit jacks
 - 1 Ultra short-wave choke, **RFC2** Eddystone 1011
 - 1 RF choke, 1.35 mH, 18 ohms resistance, **RFC1** Premier
 - 1 50 m-mfd., air dielectric trimmer, **C1** Polar C801
 - 11 Midget Frequentite insulators Eddystone 1019
 - 2 2½-in. insulators Eddystone 1028
 - 2 Octal valve holders Clix X218
 - 1 Frequentite 5-pin valve holder Eddystone 1074
 - 2 4-way connector blocks Bryce 5C2
 - 4 Miniature Direct drives Eddystone 1099
 - 2 Top cap valve connectors Belling Lee
 - 4 Shaft couplings, ¼in. bore Bulgin
 - Miscellaneous: Peto-Scott
 - 1 Aluminium screen, 4½ × 5½ in.
 - 1 Plywood chassis, 12 × 6 × 1½ in.
 - 1 Plywood chassis, 12 × 4½ × 1½ in.
 - 1 Wooden panel, 16 × 13 × ¼ in.
 - 2 Panel side supports, 12 × 6 in.
 - 2 Small insulated brackets, centre 1½ in. above base.
 - 2 Small aluminium brackets, centre 1½ in. above base.
 - 5 Pieces Paxolin, 1½ × 1½ × ¼ in., for mounting jacks; 12 in. Paxolin rod ¼ in. diameter for condenser couplings.
 - Quantity No. 20 SWG, and No. 15 SWG enamelled copper wire.
 - 2 Paxolin formers:
 - (1) ¼ in. diameter × 1½ in. long.
 - (2) 1 in. diameter × 1¼ in. long.
 - Quantity No. 16 SWG and No. 18 SWG turned copper wire, sleeving, ¼ in. and ½ in. round head No. 4 screws.
 - 12 in., ¼ in. outside dia. copper tube for P.A. tank coil.
- Valves:
- 2 6V6G valves Tungoram
 - 1 TVO3-10 valve Mullard

the filter should be unnecessary. Its inclusion would only be justified if other stations report noticeable key clicks accompanying the transmission.

usually makes when switched off. Well, I turned the thing up as far as it would go, but nothing came out of the extension. As I had been listening to the News only a

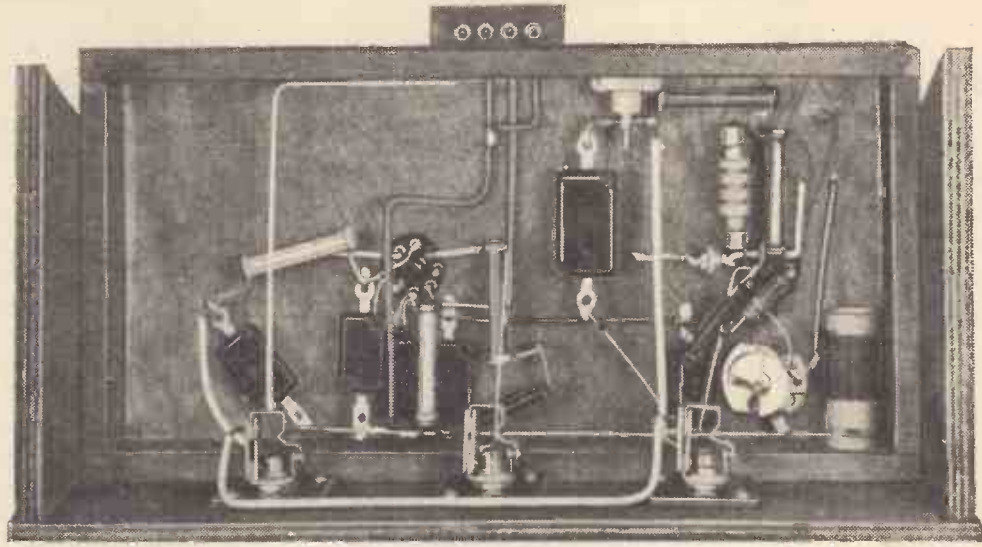

The bulk of the wiring and most of the smaller components comprising the first two valves in the transmitter are located below the chassis. Note coil L1 and condenser C1 located in the right-hand bottom corner.

Applying modulation to the final stage for telephonic or ICW transmissions can be accomplished without any change in the design or in the layout. It is only necessary to join a plug to the secondary winding of a suitable modulating transformer and plug it into the jack J5.

Though a speech amplifier capable of giving four watts output is suggested, as this is based on rough measurements of the RF output, it might be advisable to have a little audio power in hand. Moreover, with a different valve the RF output might be greater than that obtained from the particular specimen used in this set.

With the grid circuit of the output valve tuned to resonance, but with the anode circuit mistuned and no load connected, the HT current should amount to between 50 and 60 mA. Bringing the anode circuit in resonance, still without an external load, will cause a drop in anode current to about 18 to 20 mA. With optimum aerial coupling the anode current figure mentioned previously is obtained.

quarter of an hour before, when I switched the speaker off, it didn't seem that much could have gone wrong; until I saw that the extension line wasn't plugged in. Women never have any sense where electrical things are concerned. But unfortunately it was no better when the extension was plugged in, or the receiver speaker switched on.

Everything looks all right: the valves are all warm, and the aerial and earth are properly connected. What is the matter with the confounded thing now? By the way, I notice it doesn't even make the scratchy sound now.

Your Affectionate,
Uncle Adrian.

What is the most probable cause of the sudden failure?—Solution on page 542.

Applied Acoustics. By Harry F. Olson, E.E., Ph.D., and Frank Massa, B.Sc., M.Sc. 2nd edition. Pp. 494 and 278 illustrations. Published by P. Blakiston's Son and Co., Inc., 1012, Walnut Street, Philadelphia, U.S.A. Price \$5.50.

THE first edition of this work has achieved wide recognition and is to be found on the bookshelf or—more significant—on the bench of most works laboratories.

In the second edition the chapters on fundamental measurements, microphones, loud speakers and physiological acoustics have been expanded and now include additional information on sound spectroscopy, logarithmic detectors and curve traces, directional microphones and reflectors, multiple-diaphragm loud speakers, and the frequency and volume ranges of speech and music. The latter is given in a useful diagram in which the limits are represented by shaded areas.

An entirely new chapter has been devoted to horn-type loud speakers, and the scattered information on this subject given in the first edition has been collected and amplified.

The new edition is bound in washable fabric, as befits a book which is likely to be as well thumbed as its predecessor.

F. L. D.

PROBLEM CORNER—23

An extract from Henry Farrad's correspondence, published to give readers an opportunity of testing their own powers of deduction:—

99, Blomfontein Parade,
Surbiton.

Dear Henry,

Thank you, my boy, for the advice about having "tone compensation" fitted to the output pentode to make the tone a bit deeper. It used to sound like an excited woman and was quite getting on my nerves. At least, I used to think so, but now I would be glad to have even that rather than nothing at all. It was like this: your aunt came to tell me she couldn't hear it on the extension; I had the loud speaker in the apparatus itself switched off, so was no wiser until she told me; but listening to it closely there was the very faint scratchy sound it

Rooms, Booms and Decibels

ARE "STRAIGHT-LINE" AMPLIFIERS WORTH WHILE?

By N. PARTRIDGE, B.Sc., A.M.I.E.E.

A FEW weeks ago "Cathode Ray" outlined the difficulties operating against the reproduction of true bass. He showed that the lower register of the average radio set is illusionary, and ended with a brief reference to genuine high-fidelity equipment. I wonder how many readers, after they had studied the article, classed their apparatus in the latter category, and thought that the author's derogatory remarks applied solely to "cottage pianos," mouth organs, and the baser types of radio set, but not to their own receivers.

It is generally accepted by the outside world that fishing is the hobby most calculated to develop the imaginative faculty, but believe me, the "quality bug" can produce a degree of self-deception that would shame the disciples of Isaak Walton. To those who regard a loss of 1 db. at 20 cycles as an intolerable departure from perfection, I would ask, in all humbleness, the following question. Suppose that your amplifier is flat from 20 to 20,000 c/s, and suppose also that the manufacturer of your loud speaker has not exaggerated its bass-reproducing possibilities: how do you get a 50ft. sound wave into your 15ft. listening room?

The question must not be taken too literally. Of course, the sound wave doesn't have to be stretched out in a straight line. The front part of it hits the wall facing the loud speaker, and is

A GREAT deal is heard about the necessity of eliminating distortion in amplifiers and loud speakers. In this article, however, it is shown that the acoustic conditions of the average listening room have a very marked effect on the reproduction of a wireless receiver, more especially at the lower end of the musical scale. The conclusion is reached that, although "straight-line amplifiers" are highly desirable, there is no object in being too exacting in this respect.

reflected back into the room again. The wave becomes, as it were, folded up. But is a folded wave quite the same thing as one that passes on its way unimpeded?

The simplest method of reaching a conclusion is to investigate experimentally. An A.F. oscillator connected to one's amplifier will provide continuous notes of any frequency and, but for listening, the job is as good as finished.

Starting with a fairly high-pitched note, say 1,000 c/s, the existence of standing waves is the most striking thing that is brought to one's notice. To hear a standing wave at its best, close one ear by placing a finger over it, and move the head slowly from side to side. In some positions the note will sound loud, while a

movement of an inch or two will reduce it almost to nothing.

Standing waves are the result of reflections. The original wave train going in one direction has a reflected wave train travelling in the reverse direction superimposed upon it. Fig. 1 shows the mechanism diagrammatically. (a) Depicts the original wave moving to the right and the reflected wave going the other way, i.e., to the left. The sum of the two waves is shown beneath. At (b) the waves have been shifted along by one-eighth of a cycle (in the proper directions) and the sum of the two in their new positions is again drawn below. The remainder of Fig. 1 repeats the operation for successive movements of one-eighth of a cycle.

Although the two waves have been displaced in their respective directions, the series of curves showing the sum of the two does not move at all. There is no trick about it; it is just a physical fact that two waves travelling in reverse directions give rise to a wave that stands still. Hence one can find the points of maximum and minimum pressure variation by moving one's ear about and searching for them.

In passing, a few words concerning wave diagrams would not be out of place. A sound wave must not be imagined as a rapidly moving stream of corrugations in the atmosphere. It is a pity that waves on the surface of water look rather like

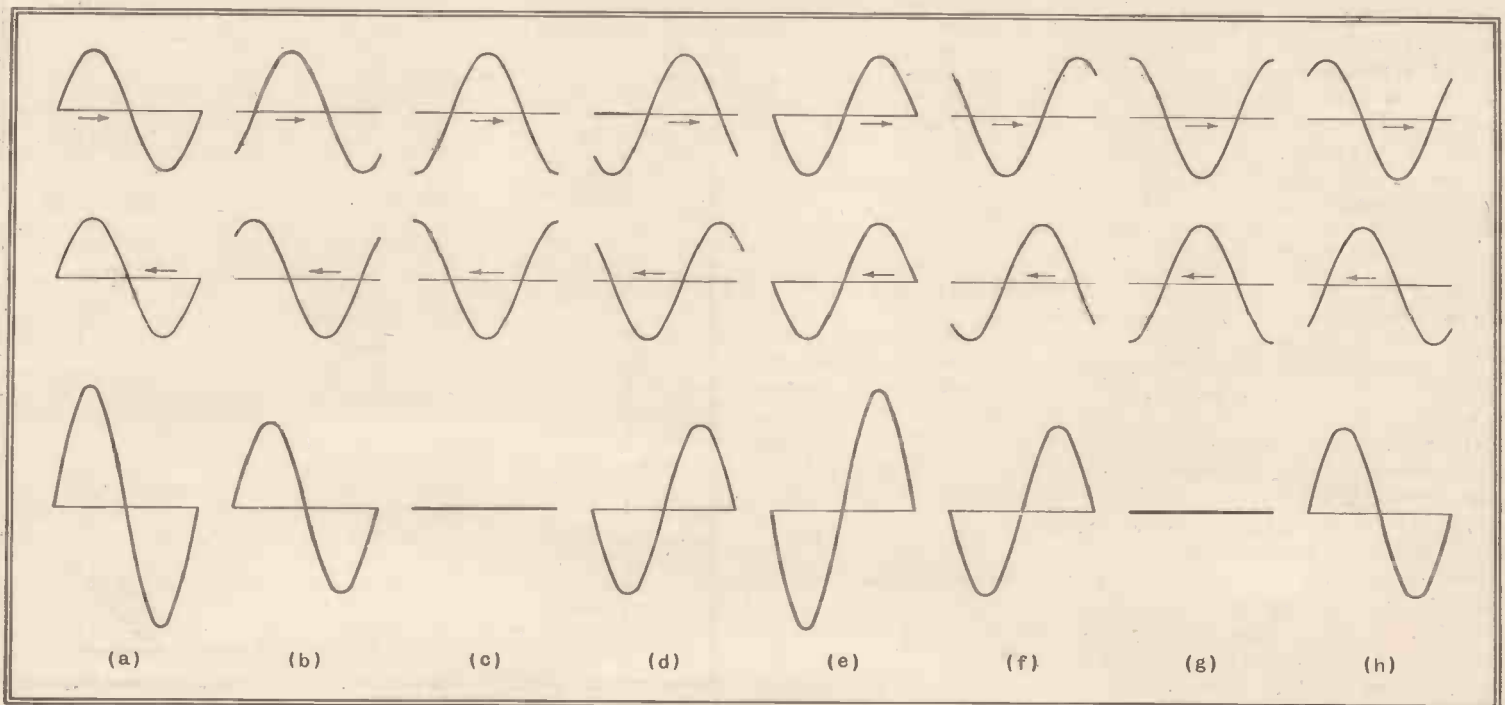

Fig. 1.—The topmost curve in each of the eight groups of three curves represents a primary sound wave, the curve immediately below it indicating a reflected version of it and the bottom curve the standing wave produced by the combination of the original and the reflected wave. It will be observed that, although the curves indicating the primary and reflected waves are shown displaced in their respective directions—there being a shift of one-eighth of a cycle in the case of each group—the curve representing the standing wave remains in the same position,

Rooms, Booms and Decibels—

the diagrams we draw of sound waves in air. There is no surface to the air in a room (except the walls), so there cannot be any surface waves. We are in the position of fish in the sea. A winkle doesn't

position is not quite the same. Three modifications must be taken into account. In the first place, the standing waves get larger and larger. A 30-cycle note has a wavelength of about 37ft., and the distance from a maximum to a minimum will

bass seemed particularly partial to the corners.

At this point a sideline observation might be recorded. At the places of minimum true bass, a disturbingly loud selection of harmonics was apparent. The very low tones produced an air vibration that shook one's clothes when standing directly in front of the loud speaker, but innumerable harmonics and extraneous noises had far more effect upon the ear than did this vibration, except in the positions of maximum boom.

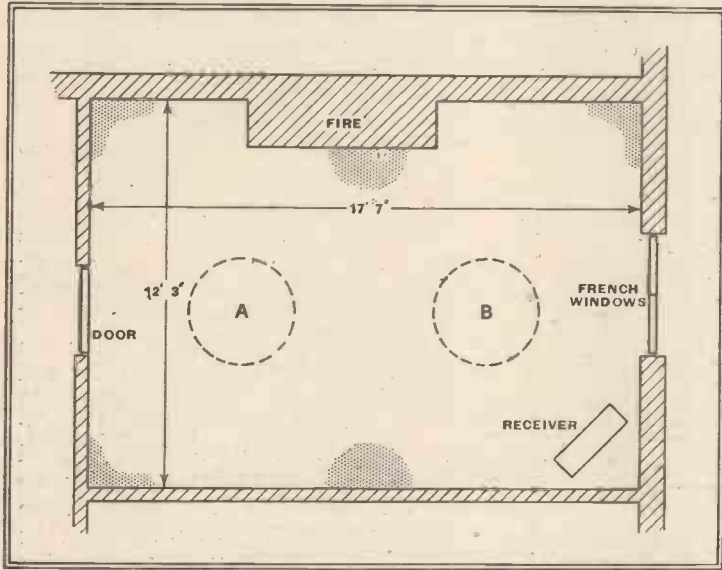

Fig. 2. Plan of the room in which the tests were conducted. The shaded areas gave a maximum of bass and of resonant frequencies. In the circles A and B, bass and resonances were present in negligible proportions, but harmonics were very prominent. The walls of the room were of brick.

see any waves; he can only feel them. As the crest of a big wave passes overhead, the pressure beneath will be greater than when the trough comes along. Thus the waves perceived by fish are variations of pressure, and so also are our sound waves. The curves of Fig. 1 represent the relative air pressures along the wave. The straight zero line is normal air pressure, points above it indicating a greater pressure and points below it a reduced pressure. If time could be stopped while we walked along a sound wave with a sensitive barometer, the variations of pressure could be measured, and would be found to follow the curves we draw of such sound waves. The ear is very sensitive to variations of pressure, and it is the rate at which the ear drum is pushed in and out by the rhythmical pressure variations of a wave train that enables us to determine its pitch or frequency.

The Production of Standing Waves

Returning to the experiments, standing waves will be detected quite easily at any frequency above, say, 500 c/s. On first listening to these enormous changes of intensity from point to point, it is a little surprising that music is not spoiled by them. Fortunately, we normally listen with two ears, and it is rare for both to experience a maximum or a minimum at the same time. Also, we are used to room effects in everyday life. Standing waves are not peculiar to loud-speaker reproduction, but occur when we talk or make any other kind of noise in a room. Thus, reproduced speech or chamber music should not be more distorted than the real thing on this account.

Going down the scale, however, the

wave to be heard at all, and then an increase of 20 db. in the intensity results in a loudness change of 50 db. Thus, the quiet patches of a standing wave will become inaudible, and the reinforced areas will seem abnormally loud.

The foregoing is not intended to be a philosophical or scientific résumé of all the factors bearing upon the behaviour of long waves in enclosed spaces. It merely indicates that trouble can be expected with reasonable certainty.

The first series of experiments at the lower end of the musical scale consisted of setting the oscillator at random, and walking around the room listening. This process did not lead to any revolutionary discovery, but proved without doubt that the distribution of sound becomes very uneven as the frequency is decreased. Generally speaking, the centre of the room was found to be dead, and the sides lively. The

Resonances and Harmonics

A second series of experiments consisted of standing in various positions, and slowly gliding up and down the scale, noting those frequencies giving maximum sound, i.e., the apparent resonances. This technique at once yielded better results.

Fig. 2 illustrates the general shape of the room and the position of the loud speaker. The shaded areas gave a maximum of bass and a very large number of resonant frequencies. On the other hand, the areas within the dotted circles gave minimum bass and practically no resonances. It goes without saying that harmonics were most audible in these areas.

I hope nobody will take exception to my rather loose use of the term "resonance." If one stands still while varying the frequency, the positions of the standing waves will alter, and as a "maximum"

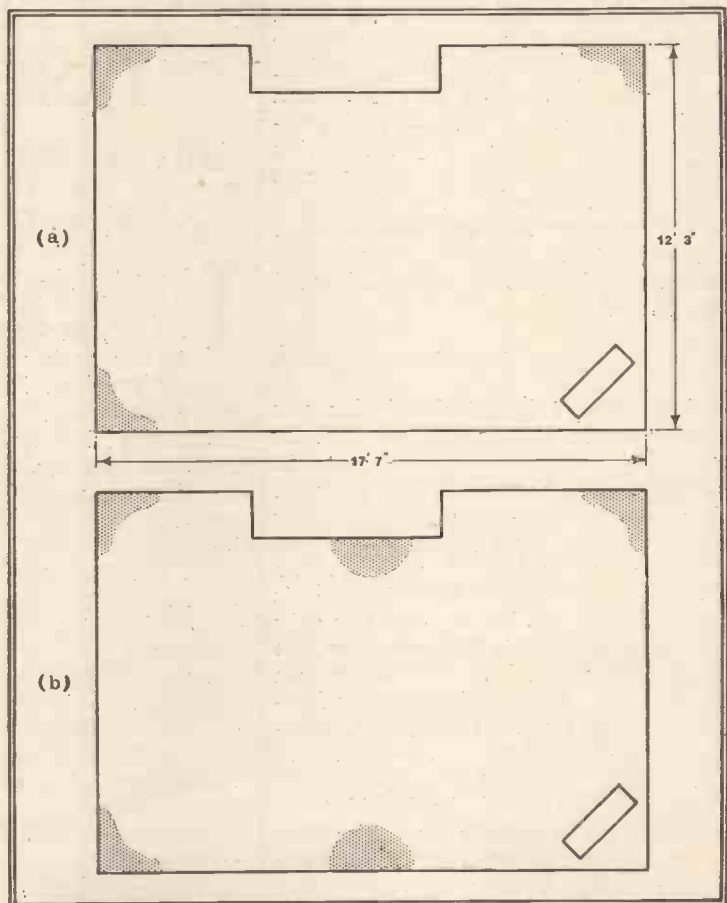

Fig. 3.—A very marked 50 c/s resonance was observed in the shaded areas indicated in plan (a), it being noteworthy that the wavelength corresponding to the frequency is roughly twice the width of the room. Another resonance occurred at 72 c/s, and gave the sound patterns shown by the shaded areas in plan (b). In this case the corresponding wavelength approximated to the room-length.

Rooms, Booms and Decibels—

approaches and subsequently recedes, the effect is very similar to that produced by resonance. It simplifies the description to use the term, and so long as we know what is meant no harm will be done thereby.

Two very marked corner resonances (so called) occurred at 50 c/s and at 72 c/s, and the sound patterns produced at these frequencies are shown in Fig. 3 (a) and (b). The wave length of a 50 c/s note is roughly 22ft. and that of a 72 c/s note 15.3ft. It will be observed that the former approximates to twice the width of the room, and the latter to the length of the room. Many more symmetrical patterns could be detected at relatively higher frequencies, but these were not fully investigated, partly because the procedure quickly induces an aspirin-defying headache, and partly because the results would not, in any case, be of any special importance.

No doubt a lot could be said about large-scale box resonance or room resonance, the effect of reverberation, and the influence of furnishing, drapery and the rest of it; but my object is not to explain the difficulty away, less still to offer a solution. I want only to state the demonstrated fact that in my room, which is probably representative of the average listening room, the most perfect equipment will *not* reproduce true bass satisfactorily. In addition, the type of bass heard depends entirely upon where one is located in the room.

A Simple Experiment

This statement is not destructive nor without value. It goes to show that far too much importance has been given to response curves as measured electrically. What does it matter if one's amplifier is 2 db. down at 30 c/s when walking across the room loses or gains dozens of dbs.? A reasonably flat response curve is obviously desirable, but it represents only a limited achievement, and is not the hall mark of excellence. No refinement can be obtained by being finicking over fractions of a decibel while the glaring imperfections referred to above are known to exist.

A partial glimpse of the horrid truth can easily be arranged by those who dare to face disillusionment. Filament circuits of AC sets are usually earthed at one side or by means of a centre tap on the transformer; thus by connecting to one pin of the first valve of an amplifier, 2 or 4 volts will be obtained. Fig. 4 shows how this circuit arrangement can be

applied to the input of the amplifier, and used as a 50-cycle source. The condenser and resistance are designed to filter out any ripple in the supply, and thereby ensure a pure 50-cycle signal.

Don't be deceived because a loud noise can be heard, or because the loud speaker vibrates with obvious gusto. Listen in the corners, under the table, near the ceiling, and in the radio cabinet.

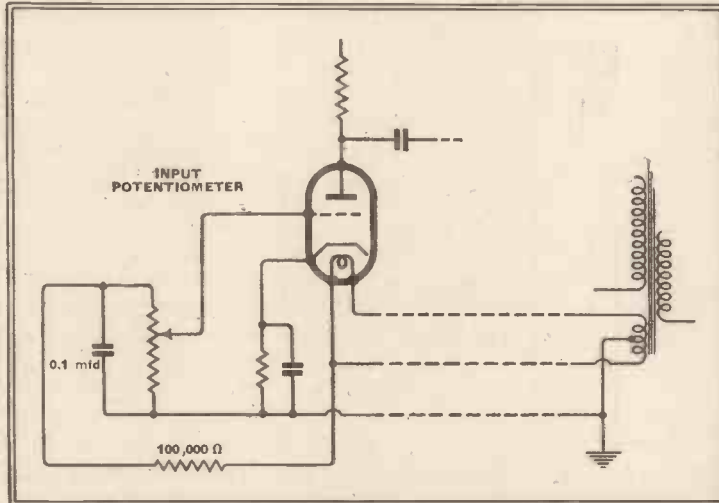

Fig. 4.—With this circuit arrangement, a 50-cycle note of variable intensity can be fed into an AC-driven amplifier from the LT winding of its mains transformer.

Experience will reveal the true 50-cycle tone. Then note how little there is of it,

how much it varies from place to place, and what a lot of additional sounds can be heard. After that, try to imagine what hope there is of hearing a 20-cycle note. By this time one or two decibels either way in the amplifier will not seem so important a consideration, and it may be appreciated that "Cathode Ray's" synthetic bass is helpful, even in the best circles.

The Summing Up

The quality enthusiast must change his outlook. Enough of this straight-line fetish. Its only effect is to encourage manufacturers to equip their laboratories with rulers instead of oscillators as being quicker and productive of more remunerative results. There are matters of greater weight upon which to focus the attention. Harmonic distortion is still too prevalent, and in the least suspected places—I hope to have quite a lot to say about this at a later date. Loud speakers, even expensive ones, by no means compare in performance with the imagined perfection of an amplifier as portrayed by its response curve. What is the use of gilding the lily while so many weeds await extermination?

But what can be done about room distortion? Well, it may be we shall have to go back to earphones for high-class listening. I really don't know. In the words of Syd. Walker, "What would you do, Chums? Drop me a postcard."

Tone-control Systems

OBTAINING VARIABLE FREQUENCY RESPONSE

By W. T. COCKING

IN most high-quality apparatus it is desirable to have some form of tone control, for the flat frequency characteristic with which an amplifier is usually provided is not always wanted. On gramophone, for instance, a rising response at low frequencies is generally desirable in order to correct for the deficiencies of recording. On radio, an accentuation of the upper frequencies may be desirable in order to counteract the effect of the tuned circuits in cutting sidebands.

For distant reception and on gramophone a reduction in the high-frequency response is sometimes necessary in order to mitigate background noise and needle scratch respectively, while the ability to reduce the bass response is also desirable—especially when speech is reproduced at large volume.

The tone control fitted to the average receiver permits the treble response to be reduced and nothing more. A control to reduce the bass response is equally easy to provide, but is rarely fitted. Controls to accentuate bass or treble are not often provided and are considerably more difficult to arrange.

Except with the aid of resonance effects, which are usually undesirable, accentuation of the bass or treble cannot be obtained without a general loss of amplification. Tone-control systems do not increase the absolute amplification at low or high frequencies, they reduce the amplification over the middle range so that the bass and treble are relatively accentuated.

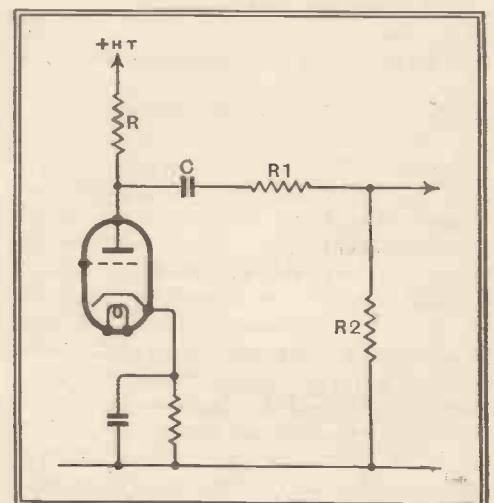

Fig. 1.—This diagram shows the basic circuit of the stage for a flat response curve.

Tone-control Systems—

If we have a stage with a gain of 30 times and we want to be able to obtain an increase of 20 db. (ten times) at 50 c/s, we cannot leave the gain at middle frequencies at 30 times and increase it to 300 times at 50 c/s. Instead, we have to reduce the gain at middle frequencies to three times only, and leave it at 30 times at 50 c/s. In practice the gain would generally have to be reduced still more, because it would be impracticable to obtain the normal 30 times at 50 c/s. If the gain of 30 times at middle frequencies is necessary another stage with an amplification of 10 times or more will have to be added.

It is this fact which accounts for the unpopularity of full tone control in commercial receivers, for there is no escaping the loss of gain. In an endeavour to minimise it, it is not uncommon to find that a designer will arrange for the full normal gain to be obtained when a flat response is required. The tone control is then arranged to reduce the gain at the middle frequencies when bass and treble accentuation is required. This method certainly gives the required frequency response

SOME of the problems encountered in the design of a satisfactory and flexible tone control are discussed in this article and design data is given. In practice, a switch-controlled system usually proves best and with two double-pole five-way switches no less than twenty-five different response curves can be obtained.

characteristic, but it is very unpleasant to use, because the major audible effect is that of a volume control!

The apparent volume is chiefly dependent upon the amplification over the middle range of frequencies and it is imperative that this be substantially constant if the tone control is to work satisfactorily. It is very inconvenient to have to readjust the volume control every time the tone control is varied.

The remedy for this state of affairs is to make the amplification over the middle range of frequencies fixed at a small percentage of the gain which can normally be secured. An arrangement of this nature has been used several times in apparatus described in *The Wireless World* and has been found extremely satisfactory.

When a level response is required, and in any case over the middle range of frequencies, the circuit takes the form of Fig. 1. The resistance R is the normal coupling resistance of an RC amplifier and C is the coupling condenser; it is made large enough in relation to the other components to exercise a negligible effect over the full range of audible frequencies.

The normal stage gain is secured between the grid and output circuits of the valve, but only a fraction of the output

voltage of the valve is taken off to feed the next stage. This is done by the voltage divider R1 R2.

Now, to obtain a response which increases as the frequency falls it is only necessary to include a condenser in series with R2, as shown in Fig. 2 (a). The reac-

tance of the condenser increases as the frequency falls, and so the impedance of the shunt arm R2 C increases; in other words, the effective ratio of the voltage divider varies with frequency.

To obtain a response rising with frequency to give treble accentuation we must

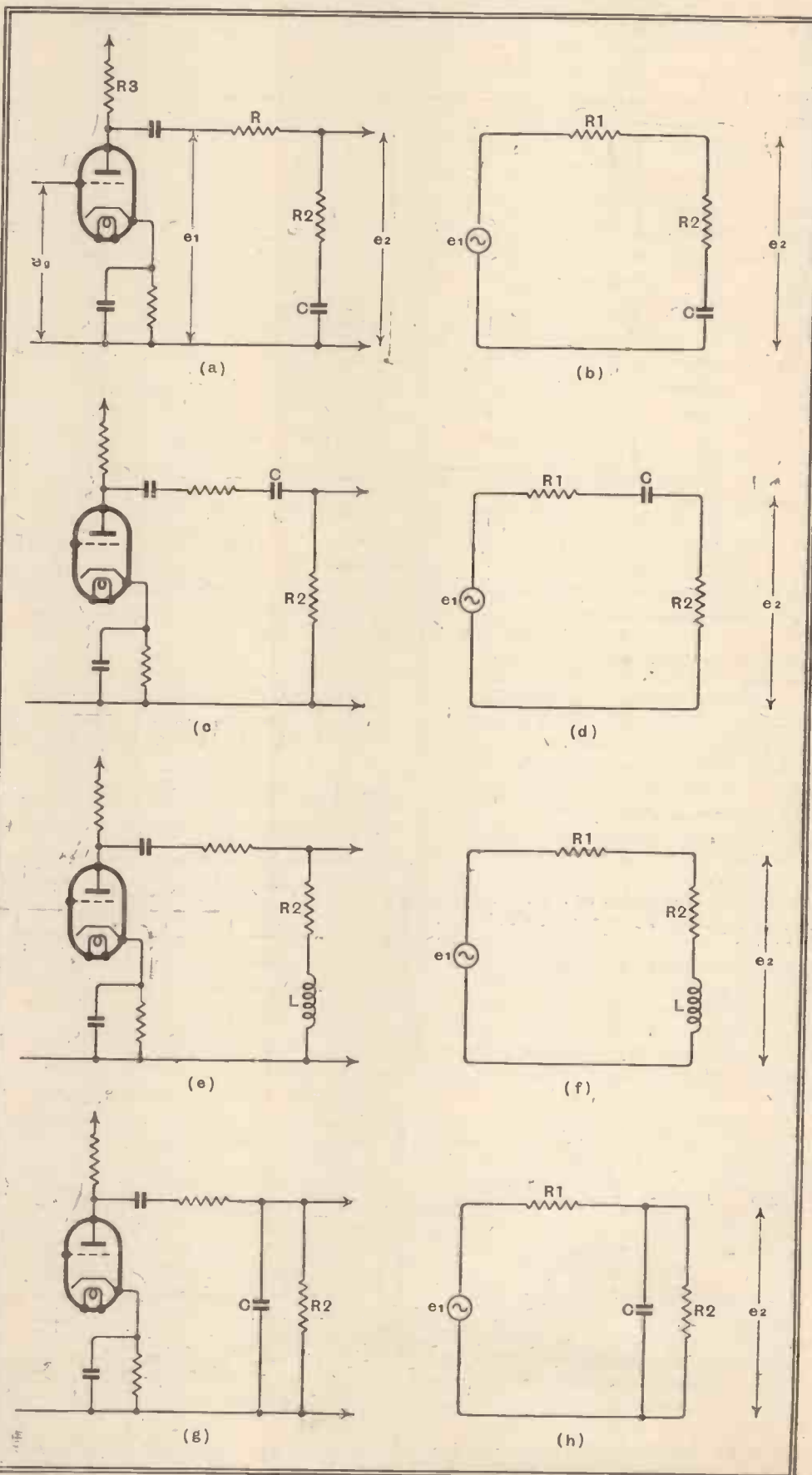

Fig. 2.—The four circuits for bass "lift," bass "cut," treble "lift" and treble "cut" respectively are shown on the left, with their electrical equivalents on the right.

Tone-control Systems—

connect in series with R_2 a reactive element which has a reactance rising with frequency; that is, an inductance. This particular arrangement is shown in Fig. 2 (e).

product $C(R_1 + R_2)$. This is shown in Fig. 3. The curve is plotted in terms of $\omega C(R_1 + R_2) = \omega t_1$ in order to make it of universal application; ω is, of course, 6.28 times frequency in cycles per second and

C is made $0.01 \mu F$, then R must be $31,800$ ohms.

The response at other frequencies can be read off from the curve; thus if $t_1 = 0.1$ at 50 c/s as above, then at $\omega t_1 = 1$ the frequency is 500 c/s and the response is -3 db. Similarly at $\omega t_1 = 0.05$ the frequency is 25 c/s and the response is -27 db.

The case of top-cut with the circuit of Fig. 2 (h) is equally simple and the response curve is given in Fig. 4. The curve is plotted in terms of $\omega t_2 = \omega C R_1 R_2 / (R_1 + R_2)$. It is again dependent on an RC product, but the resistance is now the value of R_1 and R_2 in parallel instead of in series. Suppose we want a drop of 20 db. at $10,000$ c/s, then $\omega t_2 = 10$, and as $\omega = 62,800$, $t_2 = 0.000159$ F- $\Omega = 159 \mu F-\Omega$.

Increasing Response

The circuits giving bass or treble "lift" are slightly more complicated because there are two variable factors. There is not only the time-constant of the condenser, or inductance, and resistance, but there is the amount of attenuation introduced by R_1 and R_2 to be considered. For simplicity we shall denote this attenuation by $B = R_2 / (R_1 + R_2)$, and we now have a family of curves, one for each different value of B . These are given in Fig. 5 for the case of bass-lift with the circuit of Fig. 2 (b); as before, the curves are plotted against $\omega t_3 = \omega C R_2$.

It will be seen that there is always a maximum value of B which must not be exceeded if the desired accentuation is to be obtained. For instance, suppose we want a response of $+20$ db. at 50 c/s, then it is clear that B must not be greater than 0.1 . Actually, we cannot well work on to the left-hand flat portions of the curves,

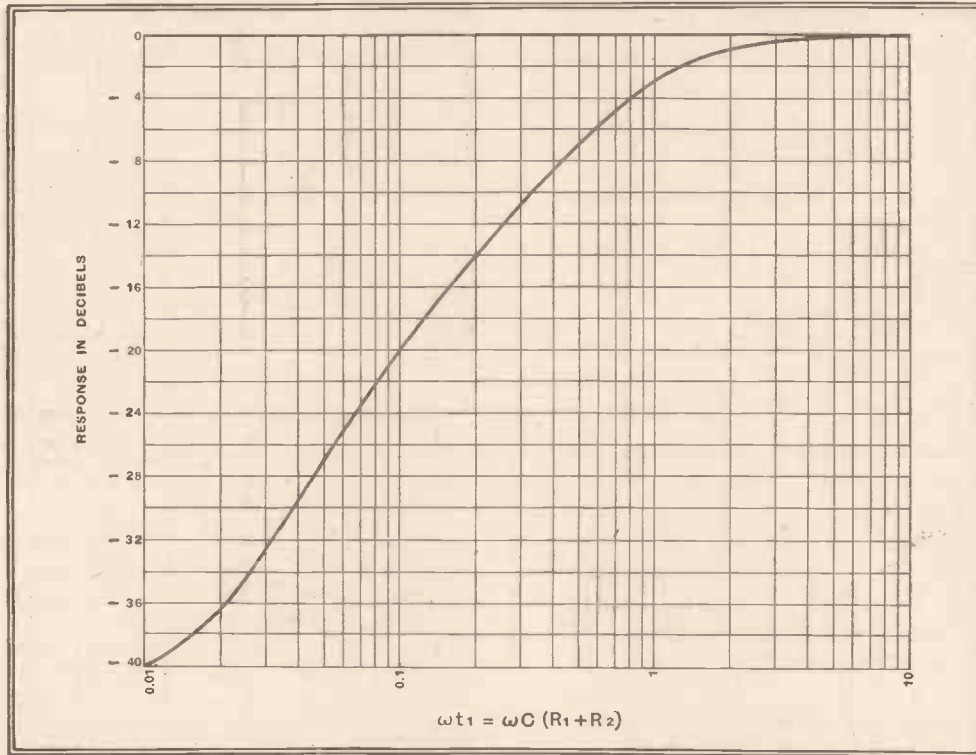

Fig. 3.—This curve applies to the circuit of Fig. 2 (c) and (d), and enables the response at any frequency to be readily determined.

To obtain a response falling at high frequencies R_2 is shunted by a condenser so that the impedance of the combination falls with frequency (Fig. 2 (g)). A response falling at low frequencies is most readily obtained by inserting a condenser C in series with the upper resistance as shown in Fig. 2 (c).

The equivalent electrical circuits are in each case shown on the right and e_2 represents the output voltage to the next stage while e_1 represents the output developed across the coupling resistance R_3 of the valve immediately preceding the corrector. The resistance R_1 includes the effective output resistance of this stage; that is, it represents the sum of the actual series resistance and the parallel value of the coupling resistance and the valve AC resistance.

The gain $\frac{e_1}{e_g}$ is normal and given by $g R_4$, while over the middle range of frequencies $\frac{e_2}{e_1} = \frac{R_2}{R_1 + R_2}$. The overall stage gain is thus $\frac{e_2}{e_g} = g R_4 \frac{R_2}{R_1 + R_2}$, where $g = \text{mutual conductance (A/v.)}$; $R_4 = \frac{R_n R_3}{(R_n + R_3)}$; and $R_1 = R + R_4$. The gain at any frequency can be obtained by multiplying this expression by other simple ones which depend upon the precise corrector used.

It is, however, simpler to use curves showing the variation in response relative to this basic value. The simplest is the bass-cut arrangement of Fig. 2 (d), for the performance obtained depends only on the

C and R are in farads and ohms respectively. As an example, suppose we want a drop of 20 db. at 50 c/s; the curve shows that $\omega t_1 = 0.1$ and for a frequency of 50 c/s $\omega = 314$, so that $t_1 = C(R_1 + R_2) = 0.1/314 = 0.000318$ F- Ω or $318 \mu F-\Omega$. The product of capacity in microfarads and resistance in ohms must equal 318 . If

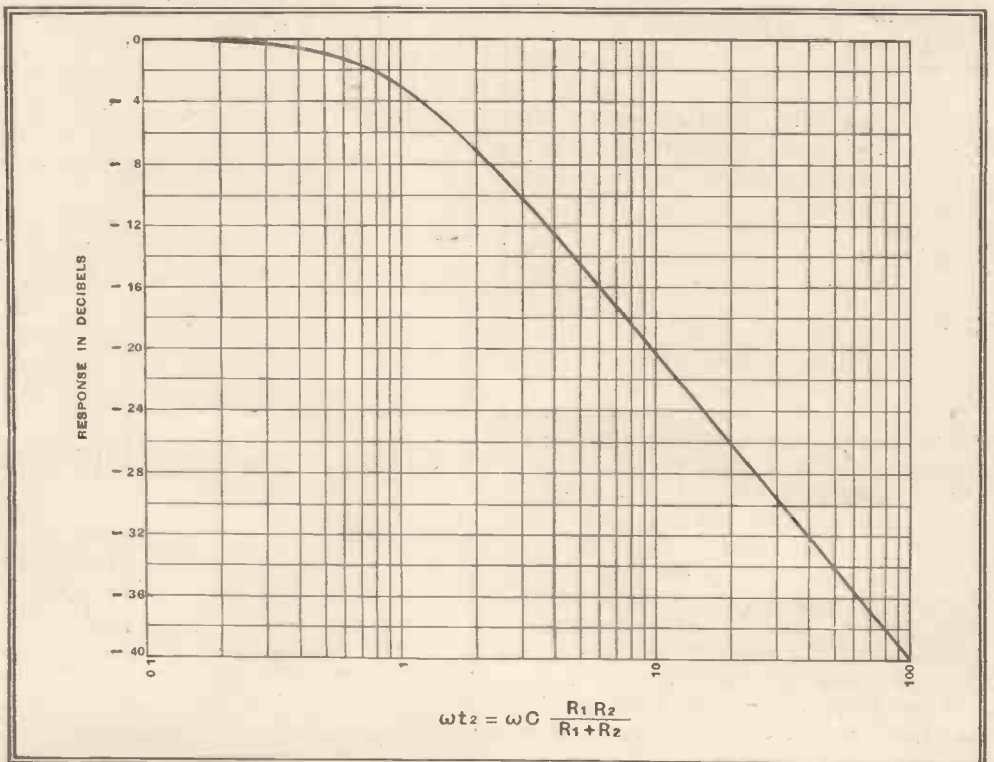

Fig. 4.—This universal response curve is for top "cut" with the circuit of Fig. 2 (g) and (h).

Tone-control Systems—

for the response is here flattening out at a maximum level and we usually want it to continue to rise as the frequency is lowered.

Suppose we choose $B=0.075$, then $\omega t_3=0.065$ for a response of +20 db. If this is at 50 c/s, $t_3=CR_2=0.065/314=0.000207$ F- $\Omega=207$ μ F- Ω . At 500 c/s, ωt_3 will be 0.65 and the response will be

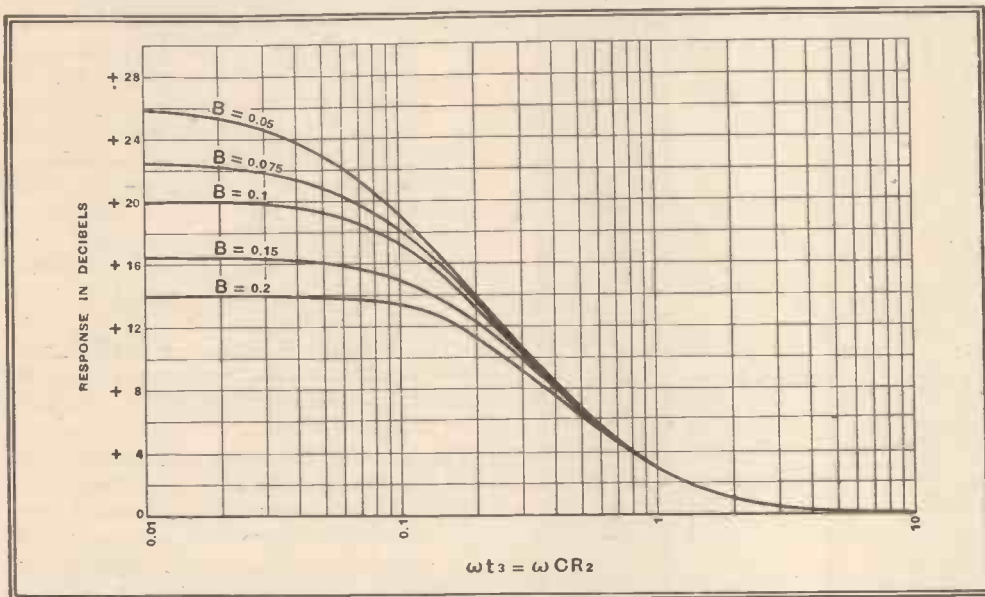

Fig. 5.—The bass "lift" circuit of Fig. 2 (a) and (b) has this series of response curves. As explained in the text, $B = R_2 / (R_1 + R_2)$.

+5.2 db., while at 25 c/s ωt_3 will be 0.0325 and the response +21.8 db.

With $B=0.05$, ωt_3 would be 0.086, so that $CR_2=274$ μ F- Ω and at 500 c/s and 25 c/s the responses will be +3.8 db. and +23.5 db. This is considerably better, for in general we want the response at 500 c/s to be as small as possible, and we want it to continue to rise below 50 c/s.

From the point of view of tone correction, the smaller the value of B the better, but unfortunately this entails a low value of stage gain. It is usually necessary to make a compromise between the requirements of tone control and those of amplification. At high frequencies, the circuit is that of Fig. 2 (f) and the two factors are B and $t_4=L/R_2$. The response curves are given in Fig. 6. A comparison with Fig. 5 shows that they are of the same general shape, but reversed from left to right; consequently, if we want similar accentuation in bass and treble the same value of B is suitable for both.

In order to show the use of these curves and to illustrate the various factors which must be taken into account, let us consider the design of a tone-control stage to precede the amplifier recently dealt with in *The Wireless World*¹. It will be remembered that this amplifier requires an input of 2.5 volts RMS or 3.5 volts peak. As experience shows that an amplifier input of some 0.5 volt RMS is about right for both radio and gramophone, under average conditions the gain of the preceding stage should be 5 times. Consequently

$$\frac{e_2}{e_1} = 5 = gR_4 B.$$

Experience also shows that at 50 c/s and 10,000 c/s a maximum lift of 20 db. is all that is necessary; in many cases a smaller lift will suffice. Reference to Figs. 5 and 6 shows that B should not be larger than 0.075 if 20 db. lift is needed. Taking this value tentatively, $gR_4=5/0.075=66.6$. This is the normal stage gain needed apart from the attenuation introduced by the tone-corrector.

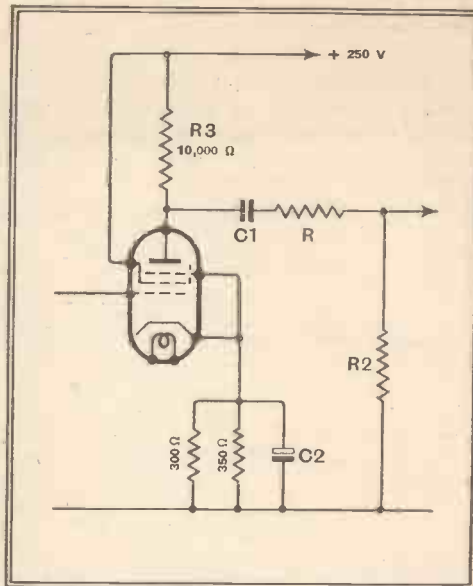

Fig. 7.—This diagram illustrates how a pentode can be used in a tone-control system. As shown here, the response is substantially flat.

large, for if it is, stray capacities across it will introduce undesirable effects.

With a triode of the MH4 class a gain of about 23.5 times is to be expected and if the overall gain is to be 5 times, B must not be less than 0.212. This limits the possible bass and treble lift to about 12 db.

Using the TSP4 with $R_3=10,000$ ohms, the maker's figures show gR_4 to be 54 times, so that $B=0.0925$. The valve will introduce about 3 per cent. second harmonic distortion; this is with a 250-volt supply for anode and screen and 3 volts grid bias. This is not the optimum condition for our purpose, however, and with an input of only 0.5 v. RMS the distortion is much lower with 2.5 volts grid bias only. The valve then takes 13 mA. anode current and 2.3 mA. screen current, so that the bias resistance should be 163 ohms—a value easily obtained by using 300-ohm and 350-ohm resistances in parallel.

The arrangement is shown in Fig. 7.

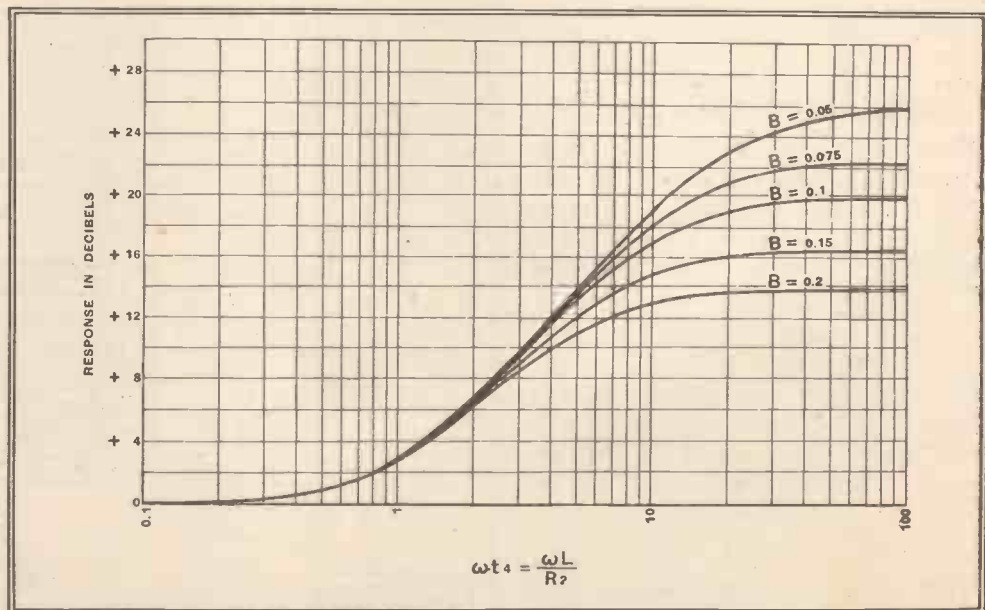

Fig. 6.—This is a similar series of curves for top "lift" with the circuit of Fig. 2 (e) and (f).

¹ "Phase-Splitting in Push-Pull Amplifiers," *The Wireless World*, April 13th, 1939.

Tone-control Systems—

where the tone-control reactances are omitted. The gain is 55.6 times, so that for an overall gain of 5 times $B=0.09$. The absolute value of R_2 can be fixed more or less arbitrarily, but it should be

+18.4 db.; the response at 500 c/s, however, would be +4.3 db.

We have already seen that this is rather much, and our best course is consequently to use two condensers in parallel— $0.05 \mu F$ and $0.015 \mu F$ —unless in arranging the

$\omega t_3 = 0.39$; the response becomes +8.4 db.

Now if instead of using a separate condenser for the full bass lift we introduce another in series with this one, we have an alternative arrangement. Actually, a $0.1 \mu F$ -condenser in series with the $0.25 \mu F$ condenser gives $0.0715 \mu F$ and makes $\omega t_3 = 0.11$. This means a lift of 16.8 db. at 50 c/s and only 2.5 db. at 500 c/s.

This seems the best arrangement, therefore, and we can arrange the switching as shown in Fig. 8 (a).

For bass cut we use the circuit of Fig. 2 (d), and from Fig. 3 we find that ωt_1 should be 0.147 and 0.41 for drops of 16.8 db. and 8.4 db. respectively at 50 c/s. The corresponding capacities are $0.0085 \mu F$ and $0.0238 \mu F$.

If we use $0.025 \mu F$ for the latter the intermediate degree of bass cut becomes -8 db. Using $0.01 \mu F$ in series with it for the full cut the capacity is $0.00715 \mu F$ and the response -18.1 db. On the other hand we can use $0.015 \mu F$, giving a total capacity of $0.0094 \mu F$, and have a response of -16 db.

This is probably the better course and the circuit becomes that of Fig. 8 (b).

At high frequencies we adopt the same procedure. For "lift," we use the circuit of Fig. 2 (f) in conjunction with Fig. 6. The value of B is unchanged, and for lifts of +16.8 db. and +8.4 db. at 10,000 c/s we have ωt_4 is 9.3 and 2.5 respectively. The inductances required are 0.735 H and 0.198 H, or say 0.75 H and 0.2 H. The circuit is arranged as in Fig. 8 (c).

For top cut the circuit is Fig. 2 (h) and we use Fig. 4. Taking the same values as before, ωt_2 comes out at 6.7 and 2.4. The corresponding capacities are $0.0235 \mu F$ and $0.00875 \mu F$. For the larger $0.025 \mu F$ is near enough; $0.015 \mu F$ in series with this gives $0.0094 \mu F$, which

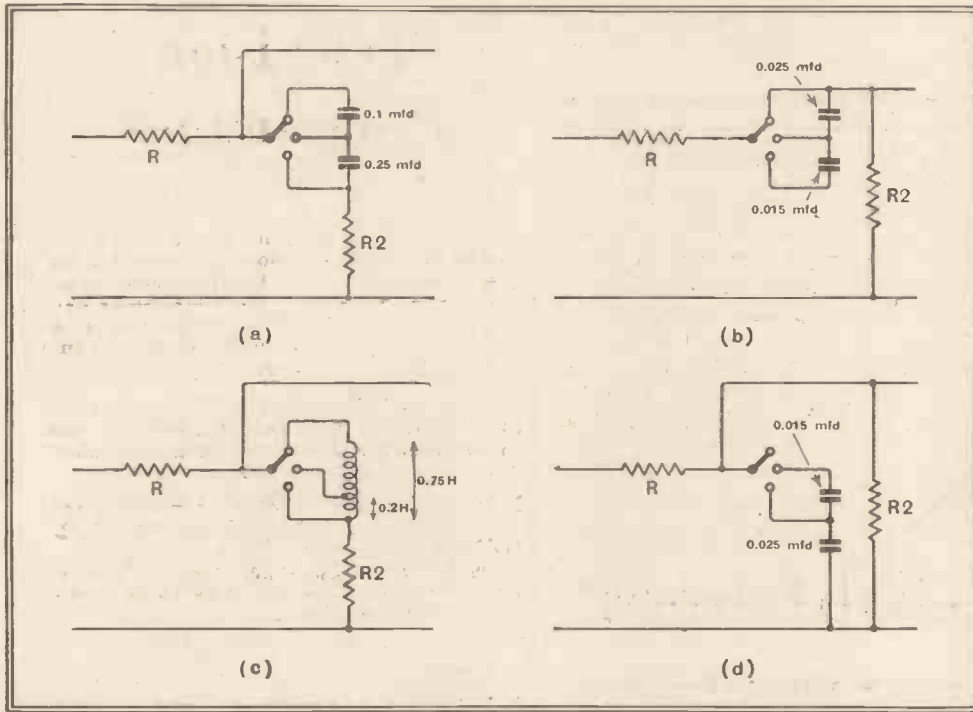

Fig. 8.—Switching arrangements are shown here for different degrees of response—at (a) for bass "lift," at (b) for bass "cut," at (c) for treble "lift," and at (d) for treble "cut."

chosen so that R is fairly large compared with R_3 . Suppose we make $R_2 = 5,000$ ohms, then $B = \frac{R_2}{R_1 + R_2} = 0.09$, so that $R_1 = 50,000$ ohms. This seems about right. Now $R_1 = R + R_3$, but as the valve is a pentode, $R_3 = R_4$ with negligible error. We thus find that as R_3 is 10,000 ohms and R_1 is to be 50,000 ohms, R must be 40,000 ohms.

The capacity of the condenser C_1 can be chosen from Fig. 3 for a negligible drop in response at 25 c/s. Say we allow a drop of 0.2 db., then ωt_1 is about 4.5 and C is $0.116 \mu F$. We can use the standard value of $0.2 \mu F$ or $0.25 \mu F$ quite well.

Choosing Circuit Values

Now consider bass lift. We have to determine C of Fig. 2 (b), knowing that B is 0.09 and R_1 and R_2 are 50,000 ohms and 5,000 ohms respectively. From Fig. 5 we see that we can work to $\omega t_3 = 0.075$ and obtain a reasonable curve with a lift of about 18.5 db. at this point. If we make this correspond to 50 c/s, we shall have a lift of about 4.5 db. at 500 c/s, which is rather much.

Suppose we say that the lift at 500 c/s is to be 3 db., then for 50 c/s $\omega t_3 = 0.1$ and the lift is about 17.5 db. This seems reasonable and we have $t_3 = 0.1 = \omega CR_2$; therefore, $C = 0.1 / 314 \times 5,000 = 6.36 \times 10^{-8} F = 0.0636 \mu F$. This is not a standard value, however, and the nearest is $0.05 \mu F$. To use this would make $\omega t_3 = 0.0785$ at 50 c/s and the response

switching another arrangement is more economical.

An intermediate stage between a flat response and the full rise of 17.5 db. at 50 c/s is usually desirable. Let us make this about 8-9 db. The factor B remains unchanged, so the new value of ωt_3 is 0.37 and $C = 0.236 \mu F$. Let us take the standard value of $0.25 \mu F$, giving

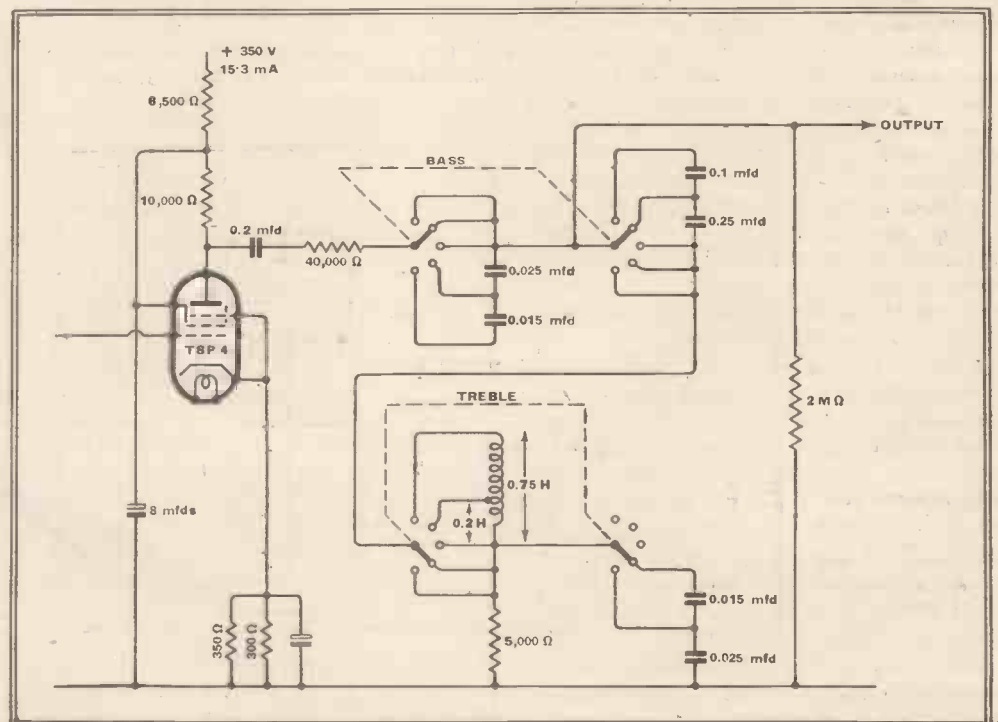

Fig. 9.—The combination of Figs. 7 and 8 leads to this complete diagram for a tone-control stage.

Tone-control Systems—

is quite close enough for the smaller. The circuit becomes as shown in Fig. 8 (d).

The complete arrangement on these lines can be controlled by two five-way double-pole switches, as shown in Fig. 9. Five different degrees of bass response and five of treble response are obtainable, the combination giving a total of twenty-five different curves.

The writer has used this system a good deal and found it very satisfactory, but there is no doubt that it has one drawback. That is, that the treble coil is liable to pick up hum if it is too near the mains transformer. This can be overcome by careful placing of the coil.

The possibility of hum pick-up, however, can be avoided by abandoning the use of a coil and modifying the circuit so that a condenser can be used instead. With the circuit of Fig. 1 it is not essential to insert an inductance in series with R_2 to obtain top-lift, for it can also be

obtained by shunting R_1 by a condenser. The curves of Fig. 6 can still be used for determining the circuit values, but B is now $\frac{R_2 + R_1}{R_1 + R_2}$ instead of $\frac{R_2}{R_1 + R_2}$, and t_1 is no longer L/R_2 but CR_1 , where C is the capacity shunting R. This value of B is to be used only for the curves of Fig. 6; when evaluating the stage gain the old value is still used.

For the same amount of top lift as with the inductance circuit B has the same numerical value, but is $(1 + R_4/R_2)$ times as great as the value which determines the stage gain. Consequently, the amplification is generally lower than with the inductance circuit; the latter actually gives $(1 + R_4/R_2)$ times the gain.

As it is always difficult to secure adequate gain from a tone-control stage, this is a serious drawback to the condenser correcting circuit, and it is one which in most cases makes the inductance method preferable.

Longer Life for Dial Lamps

NEW RECTIFIER FOR AMERICAN MIDGETS

MIDGET receivers with the dial light directly in series with the heaters of the various valves are subject to the difficulty that the set ceases to function if the lamp fails. On the other hand, if the dial lamp is in parallel with one of the heaters the total drain of the filament system is greater. As our New York correspondent points out, the new RCA half-wave rectifier tube, Type 35Z5-GT, with a tapped heater element, provides an escape from this second difficulty. As shown by the accompanying diagram, the pilot lamp is connected in parallel with a short section of the heater and at the same time is in series with the anode circuit of the tube. The rectified current through the anode circuit is, therefore, added to the current available for heating the dial lamp and the short section of the rectifier heater across which it is shunted. The dial light receives about two-thirds of its rated current and delivers about 50

per cent. of its full candle-power and, if left on continuously, its life is increased about five times. Damage due to current surge at the moment of switching on is

reduced by the fact that the rectifier does not conduct until the cathode becomes hot; accordingly, the momentary current surge is reduced by 50 mA. When the 35Z5-GT is used without a dial light across the short heater section, the heater wattage is somewhat higher and, therefore, the output is greater. Without the dial light, the voltage across the heater is 35, the short section with which the lamp is in parallel being responsible for $7\frac{1}{2}$ volts of this. The heater current is then 150 mA and the rectified current has a maximum value of 100 mA. With the dial light shunted across part of the heater, the distribution of current and voltage is, of course, changed. The dial-light fila-

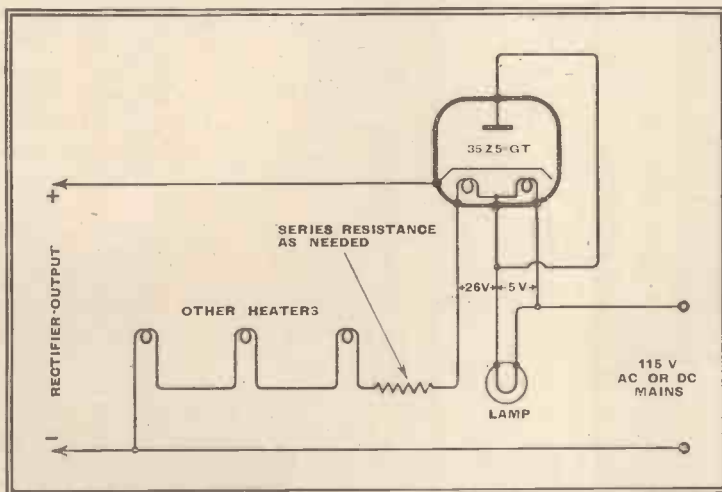

Showing how the pilot lamp is connected across one-half of the heater element of the new American rectifying valve.

ment takes approximately 110 mA, the section of heater filament in shunt with it taking 90 mA. The voltage drop across the dial light and its section of heater is

5 volts, there being 31 volts across the entire heater. The rectified current has then a value of 50 mA.

The new valve has a glass bulb and is fitted with an Octal base.

Television Programmes

Sound 41.5 Mc/s Vision 45 Mc/s

An hour's special film transmission intended for demonstration purposes will be given from 11 a.m. to 12 noon each weekday except Thursday. The National or Regional programme will be radiated on 41.5 Mc/s from approximately 7.45 to 9 p.m. daily.

THURSDAY, JUNE 8th.

- 10.45 a.m.-12.15 p.m., Trooping of the Colour in honour of H.M. The King's birthday. O.B. from Horse Guards' Parade.
- 3, Jack Jackson and his Band. 3.30, O.B. from the Royal Horse Show at Richmond. 3.45, 249th edition of Picture Page.
- 9, Phyllis Robins and Robb Wilton in Cabaret. 9.35, British Movietone. 9.45-10.15, 250th edition of Picture Page.

FRIDAY, JUNE 9th.

- 3, Foundations of Cookery—Marcel Boulestin. 3.15, British Movietone. 3.25-4, O.B. from the Royal Horse Show.
- 9, Starlight—Carroll Gibbons. 9.10, "Free to Roam"—Film. 9.20, "Living in Hollywood," talk by Molly Castle and Cedric Belfrage. 9.30, "Rococo," a comedy in one act by Granville Barker. 9.50, Cartoon Film. 9.55-10.25, "Passion, Poison and Petrification," or "The Fatal Gazogene," by Bernard Shaw.

SATURDAY, JUNE 10th.

- 3, Cabaret (as on Thursday at 9 p.m.). 3.35-4.15, O.B. from the Royal Horse Show.
- 9-10.30, "Murder on the Second Floor," a play by Frank Vosper; the action takes place in a Bloomsbury boarding house.

SUNDAY, JUNE 11th.

- 3, Elizabeth French in Songs with Evel Burns at the piano. 3.10, Cartoon Film. 3.15, A Bach and Handel Orchestral Programme with a Gothic sequence of kaleidoscopic views constituting a visual counterpart to the music. 3.50, Film.
- 8.50, News. 9.5-10.35, "Magic," a play by G. K. Chesterton.

MONDAY, JUNE 12th.

- 3-4.30, Peter Haddon in "Good Morning, Bill," a play by P. G. Wodehouse.
- 9, Gaumont-British News. 9.10-10.40, "The Insect Play," Karel Capek.

TUESDAY, JUNE 13th.

- 3, British Movietone. 3.10, Charles B. Cochran's "Night Lights" from the Trocadero Grill Room. 3.55, Cartoon Film.
- 9, Western Cabaret, No. 3, with Big Bill Campbell, Evelyn Dall and "Tenderfoot" Claude Dampier. 9.45, Acting Bee. 10.30, "The Plough that Broke the Plain"—Film.
- 11, News.

WEDNESDAY, JUNE 14th.

- 3, O.B. from Bull's Cross Farm where A. G. Street and the farmer will survey the work for June. 3.20, Vanity Fair—Furs. 3.45-4.5, Rough Island Story.
- 9, Cabaret. 9.25, Cartoon Film. 9.30, British Movietone. 9.40, Vanity Fair. 10.5-10.40, Bach and Handel Programme (as on Sunday at 3.15 p.m.).

UNBIASED

Wheels Within Wheels

IT is astonishing what a sympathetic response I have had to my recent appeal for evidence to support my view that there is an international conspiracy in being to get more work out of us by the simple process of reducing the frequency of the AC mains in the daytime, thus slowing down the synchronous clocks they control, and increasing the frequency and thereby quickening the clocks at night time. In this way, we get a shorter time in bed and more time with our noses to the grindstone. Now that the AC clock is so ubiquitous, it is easy to get people to believe that their ordinary clocks are, and always have been, erratic.

My heartstrings have been wrung by the number of letters I have had from readers thanking me for revealing what is the true cause of that "tired feeling" which they get in the morning, a subject which provides good "copy" for advertisements, so that it is quite easy to see that the big bosses in the patent food and medicine world must be in the conspiracy. They put money in their own pockets and, in addition, prevent people from tumbling to the true explanation of things.

One of the most interesting letters I have received is from a well-known bookmaker, who a year or two ago had AC mains clocks installed throughout his sumptuous suite of offices. His sole idea was to have absolutely accurate time, a thing which is vitally necessary to a bookmaker, who accepts telephoned instructions at his office right up to the moment of the "off." My revelations have led my informant to assume, with almost



Night starvation.

complete certainty, that there is a conspiracy within a conspiracy being operated, so far as he is concerned.

He has, he tells me, been much perturbed lately by the monotonous degree of regularity with which money is being won from him by the engineer-in-charge of the generating station which serves his office with electric power. Instructions are telephoned through by this client about one minute before the "off," and my informant feels almost certain that

what is happening is that ten minutes or so before each race the frequency of the local generating station is lowered so that his office clocks are two or three minutes slow, thus enabling the engineer-in-charge of the generating station to get the results from the course in time to telephone a bet on the winner.

I know so little of racing, I fear, that I can offer no opinion whatever on this matter, but if these suspicions are correct it is clear that the engineer in question will soon find himself doing time instead of doing the bookmaker.

Comme Il Faut

I WONDER if you have noticed how many of the towns of this country, more especially certain seaside resorts, are divided up into sections occupied by the "best people," and what they regard as the "untouchables." I am told that this sort of thing is rampant everywhere, and that even homely Hoxton has its "best people" section, while Mayfair most certainly has its "untouchables" area:

Lest any of you should mistakenly think that I have in mind such dual towns as Hastings and St. Leonards, Margate and Cliftonville, or Southend and Westcliff, let me tell you plainly that you are quite wrong. Contrary to popular opinion, there is no hard-and-fast "caste" system in these places. In St. Leonards, for instance, which is popularly reputed to be the best end of Hastings, there are very definitely plenty of untouchables—you can't touch them even for a drink—while in Hastings, where one might have expected a little free-and-easiness, they are, on the contrary, extremely *comme il faut*, this being due, I think, to the fact that they are still a little touchy over the French victory there in 1066. The year before the war, when I was last in Hastings (I mean, of course, the Great War, and not the Norman Conquest), I was not at all well received in a certain restaurant when I asked for something in French. My Norman accent was instantly recognised, and I was bowed out rather coldly.

The reason why I have raised this matter is that I happened to be passing through a very *comme il faut* district in Surrey the other day, and was amazed at the forest of television aerials I saw everywhere, more especially as the whole of the district was on DC supply and was also, I understood, a notoriously blind spot so far as television was concerned. I was so puzzled about it that I determined to make enquiries, and so took the opportunity of dropping into the first wireless dealer's shop I came across.

I was very much taken aback when the dealer told me that, although he had never sold even a solitary television receiver, he

By FREE GRID

was rapidly making his fortune by supplying and fixing television aerials. He explained this by the nature of the district, which was very much of the "new snobbery" type. Everybody wished it to be thought by their neighbours that they had a television set, and so everybody had a television aerial. In order to avoid the discovery that there was no television set attached to it, social visiting had almost passed out of existence, and all the local radio dealers who fixed the aerials were squared by their customers not to tell the neighbours about the non-existence of a television set attached to it.

I am fully acquainted with the old maritime wisecrack about many a smart uniform hiding a shirtless back, but this is the first time I have had the truth of it so strikingly brought home to me. It makes me wonder whether all these smart cars that are parked outside houses in cer-



Television triumphant.

tain districts are really all that they pretend to be. Perhaps you have noticed, as I have, that these cars never seem to do anything but stand outside the houses of their owners. Nothing could be easier than for a manufacturer to turn out cheap papier-mâché car bodies which were exact replicas of the more expensive cars, and I am wondering whether some manufacturer isn't doing it already. Of course, I am perfectly well aware that these cars are not *perpetually* outside their owners' houses; they are put into their garages at night. This would present no difficulty, however, as to move the cars the few feet necessary the motive power could easily be supplied by the son of the house getting under the bonnet and shoving while father sat in lordly state manoeuvring the steering wheel. The very absence of engine noise would all aid the conspiracy, as one expects an expensive car to be noiseless. After this television eye-opener nothing would surprise me. I have even begun to suspect some of my friends when I see them out with their expensively dressed wives, and wonder if, after all, there is a real flesh-and-blood woman under the clothes or merely a radio-controlled robot. I suppose that a good test would be the production of a mouse.

NEWS OF THE WEEK

SPANISH BROADCASTING

The Process of Reconstruction

WITH the end of hostilities in Spain comes the advent of reorganisation, and the broadcasting system, now under the control of the Minister of the Interior, Señor R. S. Suñer, will be one of the first services to receive special attention.

During the Civil War 70 Nationalist transmitters were in operation, and radio assumed a position of unrivalled importance. To maintain the public interest lavish expenditure is contemplated. A scheme for station construction is being undertaken immediately, and with the object of meeting some of the expenses consequent upon the plans, sponsored programmes will be permitted.

Schools, educational institutions and clubhouses of the Falangists (Nationalist supporters) are to be presented with tax-free receivers. Cultural societies, hospitals and even prisons will be exempt from holding a wireless licence. The fee for the licence is to vary from 2.5 to 100 pesetas, according to the type of receiver and the financial position of the licensee, as indicated by the amount of rent he pays on his dwelling.

Following the example of Germany and Italy, a State-subsidised Peoples Set is to be made available to the public at a nominal cost.

WIRELESS OPERATORS

Admiralty Status

IN view of the increased responsibilities of signal and telegraphist ratings in the Royal Navy and of the numerous and complex installations in modern ships, the Admiralty has announced a general promotion in these branches.

The senior wireless ratings in all large vessels and at the R.N. wireless and signal stations are to be chief petty officers. The senior wireless ratings in all "Tribal" class destroyers will also hold this rank. In smaller ships the senior wireless ratings are to be petty officers, except where only one rating is carried (such as signalman in a submarine), in which case he is to be a leading rate.

These changes will entail an increase varying from 70 per cent. in the petty officer rates to 10 per cent. in leading signalmen, in addition to corresponding improvement in prospects.

ELECTRICAL COMMUNICATIONS

The Post Office Engineering Department

WHAT is in effect the history of electrical communications in the British Isles is contained in "The History of the Post Office Engineering Department," which gives a brief yet comprehensive review of the immense development and progress in telecommunications that has been made since the Department was formed.

"The History of the Post Office Engineering Department" is No. 46 of the series of Green Papers issued by the Post Office primarily for the information of the staff. Readers of *The Wireless World*, however, will be supplied with a free copy of the pamphlet if application is made to Mr. J. H. Brebner, Controller, Press Information and Publications, General Post Office, London, E.C.1.

Although nearly a century has passed since the first electric telegraph was used in this coun-

try, it was the Engineering Department which gave the young inventor his opportunity to improve his system, and he was assisted in his experiments by a number of the engineers.

The first Post Office radio stations on the coast were primarily concerned with safety at sea. In 1926 the Rugby

THE DIFFERENCE between these two transmitters represents 25 years' progress in wireless. Reproduced from "The History of the Post Office Engineering Department," the pictures show part of the rotary disc discharge transmitter at Cullercoats in 1914, and (below) the transmitter at Wick, 1939.

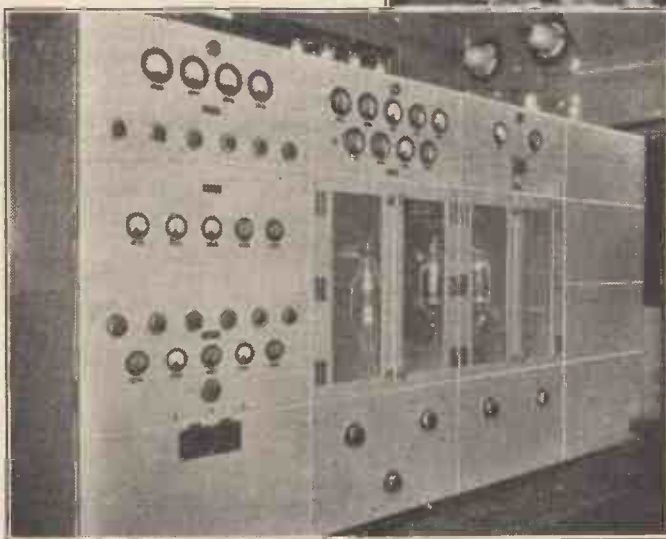
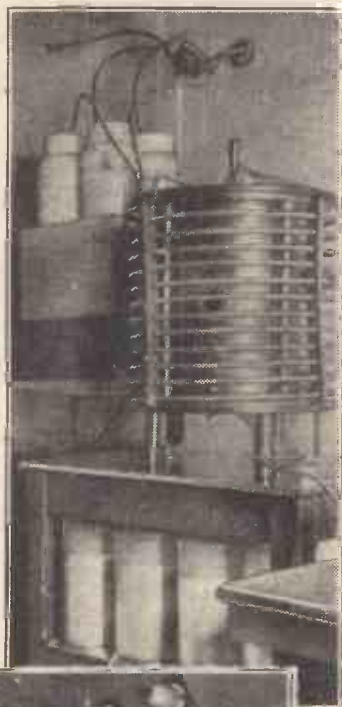

try, it was not until 1870 that all the existing telegraphs operated by a number of private companies came under the control of the Postmaster-General, and it was then that the Post Office Engineering Department was formed.

Before Marconi came to England in 1896, wireless systems were developed by P.O. En-

gineers, the greatest in the world, came into service, and within a few weeks of its opening, engineers were speaking by radio-telephone to their confrères in the United States of America. The public radio-telephone service to North America was made available in 1927. It is a remarkable story of rapid progress.

START POINT'S FIELD STRENGTH

B.B.C. and Crystal Users

CRYSTAL set owners, of which there are still a considerable number scattered up and down the country, are not being overlooked by the B.B.C. In a pamphlet which the Corporation will shortly issue regarding reception of Start Point and Clevedon, it is pointed out that crystal set users will be able to receive the former station quite clearly if a good outside aerial is used. Little hope is held out, however, for Bournemouth crystal sets unless the aerial is exceptionally high and efficient, and the crystal itself is very sensitive.

The problem of providing adequate radio coverage of the West Country has been complicated both by the awkward shape of the area to be served and its geological formation. The sub-soil of Devon and Cornwall, particularly in the Dartmoor area, is about the worst to be found in the British Isles from this point of view.

B.B.C. engineers estimate that a transmitter giving a certain strength of reception at twenty miles in this district would, over normal country, give the same strength at more than sixty miles, and, if the path of the transmitter were over the sea, at about two hundred miles. For this reason the Start Point site was chosen, as it runs so far out to sea that the path of transmission to almost the whole of the south coast is over water.

ANOTHER A.I.R. STATION ON THE AIR

Transmitting on the Medium Waves

THE longest wavelength to be used so far by the broadcasting stations in India is that of 397 metres, which has been allocated to Trichinopoly (Trichy), the 5-kW transmitter which was officially opened on May 16th.

This is the second station in South India, the other being at Madras, which uses 211 and 60.98 metres. Trichinopoly is the fifth new centre and the ninth transmitter opened by All-India Radio since December, 1937, and A.I.R. now operates eight medium- and five short-wave stations daily.

The transmitter, which is situated about five miles from the studios in the town, uses high-power Class B modulation and a quartz-crystal controlled master oscillator. The modern style of aerial, a mast-radiator 180ft. high, is used.

A receiving centre is being provided for the purpose of picking up programmes from other A.I.R. centres and Daventry. These relays will

News of the Week—

supplement the local programmes, which are at present radiated daily for four and a half hours.

TESTING AIRCRAFT TRANSMITTERS

AN Air Ministry notice to air-men states that in clear weather aircraft on the ground in the vicinity of an Air Ministry radio station should not transmit signals for testing purposes without obtaining prior authority from the station.

During QBI conditions, however, ground tests may be made at aerodromes where there is a QBI station on the QBI frequency only, without prior approval, provided that permission to proceed to the take-off line has been given. When requiring to make such a test, the operator should first listen in to ensure that he will not interrupt an established communication and should then transmit on the QBI frequency the signal QRK? SOL.

SIR HENRY NORMAN

THE death of Sir Henry Norman last Sunday, at the age of eighty, marks the end of a long and varied career. He is particularly remembered for his technical and administrative work in wireless. In January, 1910, he was the first to be appointed to the new post of Assistant Postmaster-General. He served on wireless development committees as long ago as 1913 and 1914 and was chairman of the Imperial Wireless Telegraphy Committee in 1920. He became vice-president of the Radio Society of Great Britain, a Fellow of the Physical Society, an Associate of the I.E.E., and a Fellow of the American Institute of Radio Engineers.

FROM ALL
QUARTERS

New H.M.V. Appointment

SIR ROBERT McLEAN has been appointed managing director of the Gramophone Company and the Columbia Graphophone Company. He has been a director of Electric and Musical Industries since the beginning of the year and he will retain this position.

Spanish and Portuguese Bulletins

THE daily service of news bulletins in Spanish and Portuguese for reception in Spain and Portugal which began last Sunday are broadcast on short waves only from the Daventry station of the B.B.C. on GRX—9.69 Mc/s (30.96 metres), and GSA—6.05 Mc/s (49.59 metres). The Portuguese bulletin is broadcast at 11 p.m. and the Spanish bulletin at 11.15 p.m., B.S.T.

TELEVISION IN JAPAN

Recent Advances

SEVERAL institutes in Japan, among them the Hamamatsu Higher Technical College, the Waseda University, and the Electro-Technical Laboratory of the Department of Communications, started television research as far back as

It is learned that a new station, complete with studios, is nearing completion in Tokyo, and it is hoped that this will be in use in a month or two. A mobile television unit has also been constructed and is now being used experimentally in



TELEVISION IN JAPAN. Although foreign to eyes accustomed to the more compact Emitron, the functional principles of this Japanese television camera, seen in a laboratory in Kinuta-cho, are the same. Experimental television transmissions have been carried out by the Japanese Broadcasting Corporation and plans are being made for the inauguration of a regular service at Atagoyama.

1927. Now the Broadcasting Corporation of Japan, Nippon Hoso Kyokai, is undertaking transmissions from an experimental station. The Corporation has also established a television research department, of which Prof. Takayanagi, of the Hamamatsu College, has been appointed chief.

the capital. The system used in Japan employs a new type of tube, known as the Tecoscope, which is claimed to be admirably suited to outside broadcast work. As in America, 441 scanning lines are used, with 25 pictures per second, at a frame frequency of 50, with interlaced scanning.

Television Tea Party

A TELEVISION tea party presided over by Sir Stephen Tallents will be given to television viewers at Broadcasting House on June 22nd at 4.30 p.m. Since guest accommodation is limited to 150, the applicants will probably be chosen by lot. Following an address by Mr. Gerald Cock, Director of B.B.C. Television, viewers will be invited to express their own views on the service. They will also be able to meet members of the Alexandra Palace staff. Applications, which should be posted before June 10th, should be addressed to the Director of Television, Alexandra Palace, N.22.

Police Station Radio

TRANSMITTER-RECEIVER equipment is to be installed in every chief police station in the Metropolitan area. The installations are primarily intended for A.R.P. purposes, but in peace time they will be used for urgent police matters.

Radiolympia Drive

THE Radio Manufacturers' Association has arranged a contest which will be held at leading seaside resorts from July 10th to August 14th for the purpose of finding a Miss Radiolympia, 1939. A theme song is being written for the contest by a well-known composer, and this competition, together with a comprehensive publicity campaign, is calculated to make the public thoroughly "Radiolympia-conscious" by the time the Exhibition opens on August 23rd.

I.E.E. Wireless Section

SINCE no nominations have been received other than those proposed by the Committee of the I.E.E. Wireless Section, the constitution of the Committee for the year 1939-40 will remain as outlined in these pages on May 25th. Mr. E. B. Moullin, M.A., has been appointed chairman, and Mr. R. L. Smith-Rose, D.Sc., Ph.D., vice-chairman.

Palestine Asides

ENGINEERS of the Palestine Broadcasting Service have been unsuccessful in tracing the spot where it is thought the line from the studios in Jerusalem to the transmitter at Ramallah was tapped for the purpose of superimposing seditious remarks during a broadcast on May 25th. The previous week the line was cut during an Arabic broadcast on the Palestine White Paper.

Australia's Flying Doctors

WRITING in this month's *Geographical Magazine*, Mr. Michael Terry, the Australian explorer, tells the story of Australia's Flying Doctor Service for which a simple transmitter with a telephony range of 200 miles and a CW range of 600 miles was evolved. Power is derived from a bicycle-operated dynamo, and the transmitter is operated by an automatic keyboard like a typewriter.

Police Radio

THE installation of a new ultra-short-wave transmitter in the headquarters of Stockholm's central police force marks the introduction of police radio to the Swedish capital. The transmitter, working on 9.4 metres, is in constant communication with wireless-equipped patrol cars and suburban police stations.

Garrulity on the Air

At a special conference of fishermen called by the Danish Post Office it was frankly stated that transmitter-receiver operators were unnecessarily chatty. Even though the calls were duly paid for, the bad habit of over-talkative fishermen discussing domestic problems at considerable length over the radio-telephone system was heartily resented by the Post Office. The practice was said to be causing trouble to other shipping interests on account of congestion of calls at the coast stations. It was announced that the Post Office would take measures to prevent fishermen from using their radio equipment to an unnecessarily protracted extent in the future.

Iceland's Listeners

OF every thousand of Iceland's population, one hundred and thirty are now licensed listeners. The total number on December 31st last was 15,543, which shows an increase of 1,136 for the year.

Pioneer Retires

MR. A. COPELIN, Ediswan Lamp Works Stores Manager, has retired after fifty years of service in the works where the first thermionic valve was made.

Civil Aviation Communications

A PRELIMINARY edition of the Civil Aviation Communications Handbook, which is based largely on the "Règlements du Service Internationale des Télécommunications de l'Aéronautique" (R.S.I.T.A.), has been published by the Air Ministry. It deals with aeronautical radio and teleprinter procedure, and copies, price 1s. 2d. post free, can be obtained from H.M. Stationery Office.

Wireless in the Services

INSTRUCTORS AND THEIR QUALIFICATIONS

By
G. L. MORROW

THE training of wireless personnel in any of the fighting Services is rather a different matter to the training of men as commercial wireless engineers. In the latter case, creative ability of the kind necessary for carrying out independent research is of the highest importance; in the Services, however, such a standard of technical knowledge is unnecessary and may even be undesirable. Here men are required to be not so much engineers in the true meaning of the word as operators. They must, however, in addition to being operators, possess a sound fundamental knowledge of the principles of radio communication based upon a firm, but not too extensive, grounding in the elementary theory of electricity and magnetism.

Wireless instructors in the Services must have a fairly intimate knowledge of the various types of apparatus which they will be expected to handle. While the intricacies of design will not concern them, they must be well conversant with the practical performance and construction of their equipment, be able to diagnose simple faults, and carry out repairs of a straightforward nature. It is, therefore, easily understandable why the Services, in appointing wireless instructors, tend to look more towards those who have acted as lecturers at a technical institute than to those whose teaching experience has been obtained in a more academic sphere. To

R.A.F. operators receive their practical flying instruction in planes specially equipped with a multiple installation.



At the present time there exists a great need of good wireless instructors in the various defence Services, but only men of the right type are wanted to fill the vacancies that are being advertised. In this article, the qualifications necessary for a good instructor are set out by one who has had considerable experience of this type of work. The information given should also prove of interest to those who contemplate undergoing training for any of the Services.

sum up, it may be said that a wireless instructor in the Services is in the position of teaching men a trade rather than training matriculation students for a profession.

In general, the prospective instructor must bear in mind that the conditions of general training in the Army and Air Force (and to a lesser extent in the Navy) leave only a limited period available for technical training and, therefore, such training has to conform to a rigidly defined syllabus laid down by the appropriate authorities. To this the instructor will be expected to adhere, and to plan his lectures accordingly. In so doing it is essential that he should never lose sight of one most important fact. Technical training in the Services aims at producing the largest percentage possible of men trained up to a predetermined standard of knowledge, and not the production of a few highly skilled technicians with the remainder forming the "also rans." In other words, sound collective knowledge of the subject is of higher importance than isolated examples of exceptional individual ability. The latter, of course, are bound by the law of averages to appear, but they will do so automatically, and not because the system is specially directed to their production.

Thorough Knowledge Necessary

Having thus seen what type of wireless men the prospective instructor is expected to turn out, we can now consider the qualifications necessary for the instructor himself, so that he may be in a position to carry out the task required of him. In the first place, in this, as in all other branches of life, it goes without saying that he must have a thorough and accurate knowledge of his subject. But—and this is important—the really successful wireless instructor in the Services is not, of necessity, the one possessing the highest academic and/or practical qualifications, but the one who can impart his knowledge to others in a manner calling for the least effort on the



The Royal Corps of Signals at work.

Wireless in the Services—

part of those being taught. Secondly, he should have good lecturing technique and sequence. This is largely a matter of personality helped by experience, and based on an ability to describe and explain things in a logical and clear manner. The good lecturer avoids verbosity like the plague since it merely wastes valuable time and, far from impressing his class, usually only tends to confuse them.

If the instructor knows his job, his explanations will be couched in simple language augmented, where necessary, by easily understood and familiar analogies. Again, he should never read from notes; by so doing he will inevitably destroy the confidence of his class in him because—and this is especially true of men in the Services—they will at once assume that he does so because he is not sure of his own ground. When on the barrack square the last thing they would expect would be to be drilled by a sergeant who held on tightly to a copy of "Infantry Training." The man who reads his lectures may, and often does, impart useful knowledge to a class of university graduates who already have a highly developed knowledge of the lecturer's themes, but no schoolmaster would last long in his profession were he to read his lessons to his form. The wireless instructor must therefore regard himself as a schoolmaster teaching a specialised subject, and not as a professor augmenting knowledge already acquired. In addition, he must be a strict but at the same time a just disciplinarian, but patience is equally desirable. He should remember always that what to him may



A mobile military wireless unit.

seem so obvious as to require no explanation may, to some of his class, be just the reverse.

During many years spent in lecturing to wireless students, the writer has always impressed on them that they should "pull him up" immediately there is some point which is not clearly understood by all rather than to wait until the end of the lecture, when often time and opportunity for adequate explanation no longer exist. It is far better to cover a little less ground in any one lecture, and to know that what has been dealt with is thoroughly understood and absorbed, than to cover a larger ground with the probability that there are some who have not grasped all that has been told them or, if they have, only in an imperfect manner. Obviously, this must not be carried to

In the Navy morse instruction is given to intending operators at an early age.



extremes or the instructor will be in danger of giving individual teaching rather than collective training.

To conclude, it may not be out of place to consider briefly some particular aspects of the training which instructors may be expected to give, and probably the first thing which comes to one's mind is the question of mathematics. Generally speaking, the degree of mathematical skill aimed at in wireless training in the Services is the ability to work out purely practical problems connected with Ohm's Law and the simpler expressions met with in elementary AC theory. In fact, the mathematics involved may be regarded as affording a means to an end and not an end in itself, and the standard is, in the main, less exacting than that required for the school certificate. A clear understanding of such properties as inductance, capacity, resonance, and inductive and capacitive reactance are required to be able to cope with more than the simplest mathematical presentations of such problems. Where, however, direction finding is included in the syllabus it will be necessary to add some knowledge of trigonometry.

Morse Instruction

On the electrical side, the course will be found to follow closely recognised standards of elementary electricity and magnetism with the important proviso that the more practical aspects are given prominence over those of merely laboratory importance. Especially is this the case with practical demonstrations, which are

usually designed to afford experience in the use of measuring instruments for the efficient maintenance of equipment, and its use in fault finding.

Finally, while a knowledge of morse will always be helpful to the instructor, it is not usually regarded as an essential qualification, since the teaching of morse

in the Services is nearly always carried out by N.C.O.s of many years' experience who, at the same time, can give instruction in operating procedure. Where, however, such a qualification is required to be held by the instructor, he should possess a first-class P.M.G. certificate, backed up by several years' experience at sea or with the G.P.O. The holding of an experimental transmitting licence is not regarded as a qualification.

HENRY FARRAD'S SOLUTION

(See page 529)

AN output pentode with no load to work into (both internal and external loud speakers being switched off) and not even the usual resistance/capacity tone compensation circuit to act as a safety valve (it seems from the letter that total breakdown occurred before there had been time to have this fitted) develops an abnormally high signal voltage in the anode circuit. It may have survived this when the internal loud speaker was first switched off because the volume probably was not very high, and the faint sound usually audible and due to vibration of the output transformer by signal currents was evidence that only the disconnected plug was preventing the extension speaker from functioning. When, however, the volume control was turned right up, which would probably correspond to violent overloading in any case, the output pentode would almost certainly prove unequal to the strain; and by the time the disconnected plug had been discovered there really would be a fault in the set. A new output pentode will probably be needed.

$$\lambda = 1,885 \sqrt{LC}$$

WIRELESS FORMULA NO. 1 AND ITS UP-TO-DATE EQUIVALENTS

By "CATHODE RAY"

I WONDER what emotions that title evokes? Boredom? Interest? Repulsion? "Dear me, doesn't that just bring back the old days?" "My hat, this fellow must be an antique if he still uses that formula!" Or merely what the accomplished Kai Lung would describe as "an all-pervading condition of no-enthusiasm"?

There is no doubt, I suppose, that the above formula or its equivalent comes first in importance in radio. Ohm's Law doesn't count, because it is shared with the many other applications of electricity. I say "or its equivalent" because it has so many equivalents. The above form is rather old-fashioned now we have abandoned wavelength in favour of frequency—or have we? Do many of the snappy up-to-the-minute technicians secretly cherish a guilty affection for old λ , and have to do a little furtive mental arithmetic before they can air their megacycles? One reason I selected it was because it might be the most generally recognised, even in these days when versions giving frequency are the correct style. To be quite frank, I'm not at all sure what is the generally accepted form now. Perhaps it really is a sign of my antiquity that "1,885 root LC" trips off my memory as easily as "William the Conqueror—1066." Perhaps it is the inherited cumulative effect of generations of British schooling that causes anything resembling a date to be almost instinctively committed to memory. That may be one reason for the 1,885, instead of one of the possible alternatives. Another is that in the earlier days of radio wavelengths were of such an order that \sqrt{LC} worked out to be a convenient number somewhere between 1 and 10 or thereabouts. Yet another advantage over more modern forms is that it can be printed in one line. Printers always loath fractions like $f = \frac{1}{2\pi\sqrt{LC}}$ and try to set them up as $f = 1/2\pi\sqrt{LC}$, which is loathed by the reader. One thing fairly certain is that I'll be well and truly loathed by one or other before this article is finished.

Making Things Clearer

Which reminds me that the object is not historical research into the beginnings and development of radio, but an attempt to make things clearer to readers who are not too strong in formulæ but do want to know what they mean. Well, as I said, perhaps the most important from a practical point of view, after Ohm's Law (including its elaboration to cover AC circuits), is the formula giving the resonant wavelength or frequency in terms of in-

ductance and capacity. The usefulness of it is too obvious to need any emphasising.

I don't know what your feeling is about textbook proofs. Mine usually is that the algebra is formally correct, so presumably the result is correct, but I just can't see why it should be physically. The end of a long string of mathematics may be " $\lambda = 1,885\sqrt{LC}$," and with the information that λ stands for the wavelength in metres at which a tuned circuit resonates, L the inductance of that circuit in microhenrys, and C its capacity in microfarads, almost anybody can actually use it without having any clear idea why it should be \sqrt{LC} and not LC or $\sqrt{\frac{L}{C}}$.

As I said some while ago,¹ capacity and inductance are terms that have at least been heard of by almost anybody who has had anything to do with radio, yet reactance (which is much simpler when it comes to circuit calculations) sounds very technical. The trouble is that you can't buy so much reactance; you get it as a condenser or coil, which is

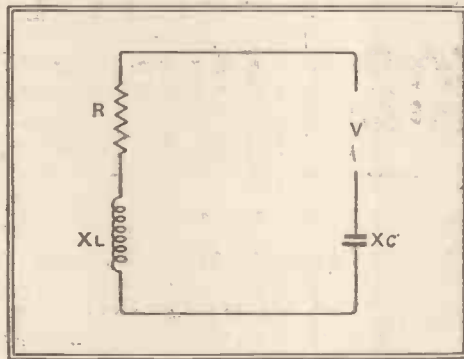

The constants of a tuned circuit.

marked in capacity or inductance, and the reactance you get depends on the frequency of the current in the circuit; if there are currents of several frequencies at once then each component has several reactances at once.

This is one of the cases in which a mechanical analogy helps, because it links up the behaviour of something that cannot be followed by the senses with something that can. If you take a heavy weight, freely supported—say a well-filled filing cabinet drawer on roller bearings—and try to make it oscillate rapidly to and fro, the greater the frequency of oscillation the greater the force you have to

exert to overcome its inertia or tendency to stay as it is. Alternatively, if you push and pull with the same amount of force, the distance it oscillates decreases as the frequency increases. The equivalents in an electrical circuit are voltage for force, current for amplitude of oscillation, inductance for weight, and reactance for inertia. It is the inertia that limits the distance a given force will vibrate the object, but the inertia of a given weight increases with the frequency. It also, of course, increases with the weight. So, changing over into the corresponding electrical terms, X_L (the inductive reactance in ohms) is proportional to f (the frequency in c/s) and L (the inductance in henrys). It is found that to make an actual equation out of them the frequency has to be expressed in smaller units— $\frac{1}{2\pi}$ times the cycles per second, to be exact—which are denoted by the letter ω . This is just an abbreviation for $2\pi f$. So the equation is $X_L = \omega L$ or $2\pi f L$.

Capacitive Reactance

The mechanical equivalent of an electrical condenser is a spring. It is actually an upside-down sort of equivalent, because capacity is the equivalent of the weakness or lack of stiffness of the spring. Therefore the greater the stiffness, the less the movement; or the smaller the capacity, the less the current and therefore the greater the reactance. So X_C (the capacitive reactance) is proportional to $\frac{1}{C}$. Also the greater the frequency, the greater the motion, and we have $X_C = -\frac{1}{\omega C}$ or $-\frac{1}{2\pi f C}$. The minus sign is due to the fact that when an alternating voltage is applied to X_L , the current lags behind it; but when applied to X_C , it leads. In the mechanical equivalent that is easy to see with inertia but not so easy to see with the spring.

Now, a tuned circuit contains X_L , X_C and R , all in series with an alternating voltage (see Fig.). The resistance may not be put there on purpose, but all coils and condensers inevitably include some of it. Obviously, the greatest current is set moving in the circuit if the total reactance is nil, because then there is only R to limit it. This condition can be put in equation form as $X_L + X_C = 0$. Filling in the details, $\omega L - \frac{1}{\omega C} = 0$, which happens when $\omega L = \frac{1}{\omega C}$. Bringing ω all to one side $\omega^2 = \frac{1}{LC}$; and taking the square

¹ "The Great Ohms Muddle," *The Wireless World*, June 23rd, 1938.

$\lambda = 1,885 \sqrt{LC}$
 root, $\omega = \frac{I}{\sqrt{LC}}$. If you want to calculate frequency, $2\pi f = \frac{I}{\sqrt{LC}}$, or $f = \frac{I}{2\pi \sqrt{LC}}$.

That is quite a workable formula now, but still not quite the most convenient, because L is in henrys (which is useful only for audio-frequency circuits) and C is in farads (which is never useful). According to the units that are most convenient, one can use a variety of "constants" in the formula, for example:—

	f in:—	L in:—	C in:—
$f = \frac{1}{2\pi \sqrt{LC}}$ or $\frac{1}{6.283 \sqrt{LC}}$	c/s	Henrys	Farads.
$f = \frac{1,000}{2\pi \sqrt{LC}}$ or $\frac{159.2}{\sqrt{LC}}$	$\left\{ \begin{array}{l} \text{c/s} \\ \text{kc/s} \\ \text{Mc/s} \end{array} \right.$	$\left\{ \begin{array}{l} \text{Henrys} \\ \text{Microhenrys} \\ \text{Microhenrys} \end{array} \right.$	$\left\{ \begin{array}{l} \text{Microfarads.} \\ \text{Microfarads.} \\ \text{Micro-microfarads.} \end{array} \right.$
$f = \frac{1,000,000}{2\pi \sqrt{LC}}$ or $\frac{159,200}{\sqrt{LC}}$	kc/s	Microhenrys	Micro-microfarads.

The middle one is perhaps the best to remember for all-round use, for it includes all frequencies, together with suitable units for those frequencies; and if there is no need to be very accurate, the 159.2 can be taken as 160.

And, because electric waves travel 300,000,000 metres per second, the number of waves per second multiplied by the wavelength in metres of each wave is equal to 300,000,000. In brief, $f\lambda = 300,000,000$, or $\lambda = \frac{300,000,000}{f}$, or $f = \frac{300,000,000}{\lambda}$. So if you prefer to use wavelengths (and it certainly makes a tidier formula, and spares the printer) you can substitute in any of the foregoing formulæ and get:—

$\lambda = 1,885,000,000 \sqrt{LC}$ L in henrys; C in farads.
 or $1,885 \sqrt{LC}$ L in microhenrys; C in microfarads.
 or $1,885 \sqrt{LC}$ L in microhenrys; C in micro-microfarads.

The last of these is the most suitable for present-day use. If you have a coil of a certain inductance, and a condenser variable between certain limits, these formulæ can be used for working out the tuning range. (But don't forget to include all the circuit capacities.) Or the components required for a wavetrap to keep out a strong station or prevent IF breakthrough can be calculated. And many other things.

Choosing L's and C's

One fact that is clear from the formula is that, to tune to any given frequency or wavelength, any inductance or capacity will do so, provided that when multiplied together they reach the right amount. Theoretically, one could use a 100-henry choke as an ultra-short-wave tuning coil. But in practice things like this are impossible, because the choke itself contains far

more than the necessary capacity, let alone the circuit wiring and tuning condenser. When there is a choice of L's and C's that give the right LC, they are selected to give a suitable impedance to the circuit, or the right amount of selectivity.

Selectivity—I mustn't start on that subject, but this is where R comes in. For a sharply tuned circuit it should be only a hundredth of XL, or even less. In other words, $\frac{XL}{R}$ should be 100 or more, and this is the quantity that is generally denoted by Q, and called the "goodness"

of the coil. Suppose that in the Fig. XL and Xc are equal to 500 and -500 respectively, so that the circuit is in tune. V is, say, 10 millivolts (0.01 volt). If the resistance of the condenser is negligible, and the Q of the coil is 125, R is $\frac{500}{125}$

or 4 ohms, and the current is $\frac{10}{4}$ or 2½ milliamps. The voltage across either reactance, XL or Xc, is reactance multiplied by current, namely, $500 \times 2\frac{1}{2}$, or 1,250 millivolts (1¼ volts). So the voltage appearing across either coil or condenser is 125 times the amount that was introduced into the circuit. It is always Q times V, so Q is sometimes called the magnification of the coil or circuit. The apparent absurdity of a voltage across part of the circuit being much greater than the whole is, of course, accounted for by the fact that the two reactances are of opposite sign, so that the voltages across them are in opposition, leaving the original 10 millivolts to drive 2½ milliamps through 4 ohms, just as in the simplest Ohm's Law.

Perhaps that is so delightfully simple as to be a good note on which to close!

News from the Clubs

Kilmarnock and District Short Wave Society

Headquarters: Wardneuk Receiving Station, Glasgow Road, Kilmarnock, Scotland.
 Meetings: Tuesdays and Thursdays at 8 p.m.
 Hon. Sec.: Mr. R. Mitchell, 151, Bonnyton Road, Kilmarnock, Scotland.
 The Sunday meetings are being discontinued during the summer months. It has been arranged that at the Thursday meetings Mr. A. Herring will give a series of lectures dealing with short-wave receiving and transmitting.

Dollis Hill Radio Communication Society

Headquarters: Braintcroft School, Warren Road, London, N.W.2.
 Meetings: Wednesdays at 8 p.m.
 Hon. Sec.: Mr. E. Eldridge, 79, Oxgate Gardens, Criklewood, London, N.W.2.
 On April 11th a junk sale was held. On April 25th Mr. Ash gave a talk on rendering first-aid in cases of electric shock, and on May 9th G8PI gave an interesting talk on frequency control of amateur transmitters.

South London and District Radio Transmitters' Society

Headquarters: Brotherhood Hall, West Norwood, London, S.E.
 Meetings: First Wednesday in the month.
 Hon. Sec.: Mr. S. H. Chapple, 7, Rutherford Close, Ewell, Surrey.
 The lecture on "X-rays," given by Mr. Stone, proved to be of exceptional interest. Mr. Stone demonstrated his X-ray apparatus, including a home-made 50,000-volt transformer. Future activities include a general

In Forthcoming Issues

Among other topics to be discussed in *The Wireless World* during the next week or two are:—

RECEIVING AERIALS.—The modern vertical rod aerial critically compared with the more orthodox inverted "L" type.

HOME RECORDING.—Constructional details of an inexpensive amplifier for operating a record cutter in conjunction with a standard broadcast set.

LINE DEFLECTORS.—Detailed descriptions of magnetic systems of deflection as used in cathode-ray tubes.

discussion on aerials to be held in June, a lecture on grid-controlled rectifiers, which will be given in July, by Mr. Nixon, of the G.E.C., and a talk on television receivers to be given in August by Mr. Wright.

Romford and District Amateur Radio Society

Headquarters: Y.M.C.A. Red Triangle Club, North Street, Romford, Essex.
 Hon. Sec.: Mr. R. C. E. Beardow, 3, Geneva Gardens, Chadwell Heath, Essex.
 The Brentwood and Southend societies took part in the test field day held on April 15th. Events of the past month have been a junk sale and an interesting lecture given by Dr. Bosch, of Vacuum-Science Products, Ltd. The Club amplifier was put to good use at the National Service Rally at Maylands Aerodrome.

Surrey Radio Contact Club

Headquarters: 79, George Street, Croydon, Surrey.
 Meetings: First Tuesday in the month at 8 p.m.
 Hon. Sec.: Mr. S. A. Morley, 22, Old Fareleigh Road, Selsdon, Surrey.
 At the May meeting of the Club a very interesting talk was given by Mr. J. H. George entitled "Modern High-speed Telegraphy." The lecturer illustrated his remarks by films showing the working of receiving and transmitting apparatus.

Ashton-under-Lyne and District Amateur Radio Society

Headquarters: Commercial Hotel, 86, Old Street, Ashton-under-Lyne, Lancs.
 Meetings: Alternate Wednesdays.
 Hon. Sec.: Mr. K. Gooding, 7, Broadbent Avenue, Ashton-under-Lyne, Lancs.
 On May 19th several members visited the *Daily Herald* office at Manchester, with the intention of inspecting the phototelegraphic apparatus. This was not possible, but, nevertheless, an interesting evening was spent. Members intend to take part in the 56-megacycle field day on July 9th, using G3BY's transmitter, operating on a frequency of 59,212 kilocycles. Work is going steadily ahead with the arrangements for the preliminary tests of the 56-megacycle field day gear. These tests will be held on June 25th, at Hartshead Pike, which is about 900ft. above sea level. Schedules are wanted with other 56-megacycle transmitting or listening stations, and those interested are invited to communicate with the secretary. It is hoped to arrange for a new clubroom very shortly when a transmitting licence will be applied for. G3BY, whose transmitter consists of 6J5 crystal oscillator and 6V6 frequency doubler, is at the moment experimenting with a "W8JK" antenna and would welcome reports.

Salisbury and District Radio Society

Headquarters: St. Mary's School, Barkers Lane, Sale, Lancs.
 Meetings: Thursdays at 7.30 p.m.
 Hon. Sec.: Mr. S. C. O. Allen, 31, Ennerdale Drive, Ashton-on-Mersey, Lancs.
 Mr. N. Postles is giving a series of lectures dealing with the theory of radio receivers and the design of a simple short-wave set.
 The Society has discussed the possibility of taking part in the National Service scheme, and a letter has been sent to the local A.R.P. authorities stating that as amateur radio is being used in some districts for emergency communications, members would co-operate in any local efforts for which the use of radio would be officially recognised.

Slough and District Short-wave Club

Headquarters: 35, High Street, Slough, Bucks.
 Meetings: Alternate Thursdays at 7.30 p.m.
 Hon. Sec.: Mr. K. A. Sly, 16, Buckland Avenue, Slough, Bucks.
 At the last meeting it was decided to form a group to correlate meteorological conditions with the propagation of radio waves. Eight members agreed to co-operate in listening at set times.
 Mr. Gilbert has invited members to visit his station at 184, Stoke Poges Lane, Slough, at 8 p.m. on June 8th. The June 22nd meeting will be held at headquarters as usual.

Automatic Frequency Control

DIRECTLY STABILISED OSCILLATOR

THE need for a high degree of frequency stability in the local oscillator of a superheterodyne is particularly great when the receiver is intended for the reception of telegraphy, and especially for short-wave reception. In the case of CW telegraphy a slight fluctuation of the oscillator frequency may cause the beat tone to drift out of the range of audibility. On short waves matters may be so bad that a relatively small frequency change may actually be large enough to move the IF signal outside the pass-band of the amplifier.

It is, in practice, very difficult to obtain a sufficiently high degree of frequency sta-

bility of the oscillator, because several other conditions have to be fulfilled at the same time. Automatic frequency control is consequently often used for the purpose of maintaining the oscillator frequency constant. In this arrangement a control potential is obtained from the output of the IF amplifier and this potential depends upon the magnitude and direction of deviation of the intermediate frequency from the required frequency. This control potential is employed to vary the tuning of the oscillator and so to correct for any drift.

This arrangement is not always practicable, however, as it operates only when

the transmitter to be received is working. In commercial practice it frequently occurs that a transmission is expected at a certain time, and there is always the danger that it will not be heard because the oscillator frequency has become displaced from its correct value.

This difficulty can, however, be overcome by deriving the control potential from the oscillator directly instead of via the IF amplifier. One arrangement is shown in Fig. 1, where the receiver proper is marked E and the control arrangement R. The receiver consists of an RF stage V1, a mixing stage V2, an oscillator V3, and intermediate and audio-frequency sections IF, AF. From the oscillator V3 the oscillator frequency f_0 is taken to the control arrangement R by means of inductive coupling. This control arrangement consists of the discriminator circuits, which are of the same type as those in the usual AFC system.

As shown in Fig. 1, the discriminator has two tuned circuits L1 and L2 coupled together and connected so that opposing DC potentials occur at the output resistances R1 and R2. When the oscillator frequency f_0 is identical with the natural frequency of the circuits L1 and L2 the two potentials at R1 and R2 are equal and opposite and, therefore, neutralise each other. When a deviation from the required frequency exists, however, a control potential is produced which operates a motor M through a change-over relay Re or through an amplifier. Instead of the motor, other electro-mechanical devices can be used, or one of the more usual purely electrical systems, such as a valve arranged to act as a variable reactance. It will be readily seen that the oscillator frequency f_0 is always maintained very close to the required value to which the circuits L1 and L2 are tuned, whether the transmitter to be received is in operation or not.

Mazda Valve Reference Chart

AN interesting reference chart for valves has been produced by the Edison Swan Electric Co., Ltd., and it takes the form of an eight-page loose-leaf folder measuring in. by 15in. and arranged for hanging on a wall. A press-stud binding is used so that the pages can be replaced from time to time.

One page is devoted to a list of the Mazda valve types equivalent to those in other ranges, and one to valve base connections. The remaining six pages give the characteristics of Mazda valves in tabular form; here there is one sheet for battery valves, one for universal types, and two for AC models. Special types and "earlier types" each have a page to themselves.

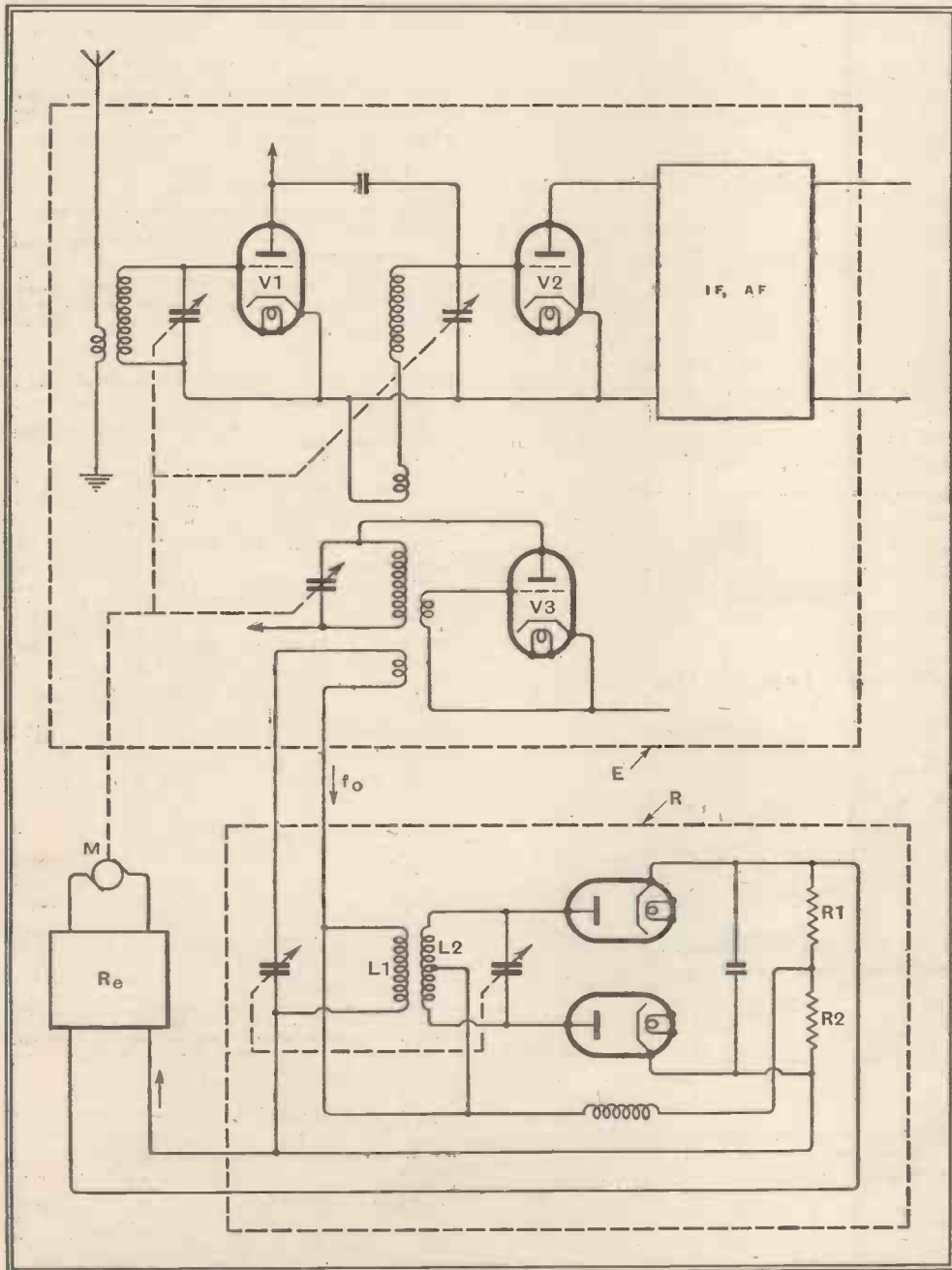

Fig. 1.—This diagram shows the circuit arrangement for stabilising the oscillator of a superheterodyne.

Random Radiations

Startling Figures

THE Listeners' League and the Listeners' Service Bureau have just completed an enquiry into the prevalence of interference with wireless reception. Replies to the questionnaire sent out were received from 4,306 people living in 80 towns and districts of England, Scotland and Wales. Only four London districts (Battersea, Kensington, Putney and Sloane Square) are included in the list; nor do some of the more notorious centres of interference figure in it. It may, therefore, be taken as providing what our American friends would doubtless describe as "a representative cross-section of the position of the whole body of British radio listeners." The prevalence of interference is neither exaggerated by a heavy volume of replies from industrial areas, nor minimised by an undue number from others. Of the 4,306 listeners who filled in the questionnaire, 2,799 report freedom from interference; but 1,507, or 35 per cent. of the total, suffer from it. A pretty state of affairs for the eighteenth year of broadcasting in this country that seven listeners out of every twenty should have their reception spoilt by unwanted noises of man-made origin!

The Commonest Cause

But that's only part of the story. Of the 1,507 who experience interference no fewer than 707 believe that the unwelcome noises that accompany broadcast programmes—or make their reception impossible at times—are due to radiation by domestic electrical appliances. In other words, such appliances are responsible for interference in 16½ per cent. of the homes from which the replies come. If, as I believe, the replies are representative of listeners at large, this figure shows a truly lamentable state of affairs. Allowing for car-radio sets in the receiving licence total, there are, in round figures, some 8,800,000 homes in this country equipped with wireless. If 16½ is a correct percentage, then in 1,452,000 of them domestic electrical apparatus installed by their neighbours is interfering with enjoyment of the broadcast programmes. Such apparatus is by far the commonest cause of background (or foreground) noises. Machinery (372) comes next, and after that electric transport with 335 cases.

Growing Doubts

These figures make one think a bit. For years *The Wireless World* has been urging



By "DIALLIST"

the Government to tackle the problem, pointing out again and again that every month of delay is making it more difficult to do so. Can it now be tackled at all with any hopes of success? I confess that I'm becoming doubtful. With all this mass of radiating appliances installed in homes throughout the country you cannot now enact that it shall be illegal to cause interference from a date a few months ahead. If real hardship is not to be imposed on householders who have bought appliances that were perfectly legal at the time of purchase, years must now be allowed for the normal service life of the things. Why the authorities did not long ago issue a warning I cannot think. Surely it would have been simple enough to announce that legislation was pending, that it would render the radiation of interference illegal and that those who in the meantime chose to buy radiating apparatus must do so at their own risk. An announcement of that kind made five years ago would probably have cut down interference by 75 per cent. to-day.

Poor Coverage

ONE thing that strikes me about some of the lower-priced receivers is their too limited wavelength coverage. Quite a few of them won't tune properly down to anywhere near the bottom of the medium-wave band, though we've had British stations working on 203.5 metres for years. This is a point that will have to receive attention in the new models if they are to be fully up to their work when the Montreux Plan comes into force. Then there's the short-

wave range. Heaps of sets go very little below 19 metres, which must have cramped their owners' DX style not a little during the past few weeks. Since the coming of summer the 19-metre band has generally been of little use, except for Europeans, until well into the evening. The 16-metre band, though, has been very lively at times. It seems to me that if the "all-wave" receiver is to be retained as a worthwhile type it should certainly cover the 16-metre band and probably the 13-metre band as well. But is it, after all, a worthwhile kind of receiver?

The "All-wave" Set

Beyond any question, it is if its short-wave range is well designed, well made and equipped with satisfactory tuning arrangements. But in so many of the low-priced sets the short-wave range hardly merits such a description; it couldn't possibly do so, for it is a comparatively expensive business to produce the circuits and the tuning system that are needed for good performance on the short waves. My experience is that many—probably most—of those who buy such receivers hardly ever turn the wavechange switch to "short"—after the first week or two of ownership, at any rate. Wouldn't it be better to put the money into improving performance on the medium and the long waves and to scrap the short-wave range in the cheaper sets? If the "all-wave" receiver were made a semi-luxury set I believe that there would be a good market for it. Those who want to be able to hear short-wave stations would probably part willingly with an extra pound or two (and exchange their old sets for new ones) if the advantages of a set with respectable performance and easy tuning between, say, 13 and 60 metres (in two wavebands) were properly brought home to them.

Wire-pulling

THE other day I was surprised to read in an American paper that quite a number of Uncle Sam's citizens lose their lives each year through grabbing the leads instead of the Bakelite body when they want to pull a lighting or power plug from its socket. One would have thought that that kind of thing wouldn't happen in a country that has been so extensively "electrified" for so many years. Yanking plugs out by the leads is certainly a reprehensible habit. It is not unknown in this country, though I don't remember ever having seen a report of a fatal accident caused in this way here. Most of the plugs that we use nowadays are more or less safeguarded against the misdeeds of wire-pullers by having some kind of anchorage for the leads. Does the American citizen use less up-to-date plugs? Or is it that those who connect up the leads don't always trouble to make use of the anchoring points provided? Personally, I'm rather particular about plugs. The kind I like best are mushroom-shaped, with the leads going in at the side and not through the top.

Too Much Noise

TO me the remarks on volume level in recent issues of *The Wireless World* have been of special interest, for I have always been against the noisy loud speaker.



A COMPACT PA UNIT

In this neat trailer, designed by Grampian Reproducers, Ltd., are contained a 15-watt amplifier for AC mains or 6-volt DC operation, gramophone turntables, microphone cable drum with spring winder and a petrol engine-driven dynamo for charging the accumulators. The trailer is fitted with levelling jacks and automatic brakes and is balanced so that it may be towed with the speakers in either position.

Mr. Briggs's measurements with a noise-meter confirm my own long-standing belief that you don't need many watts of undistorted output in order to obtain natural-sounding reproduction in the average home. Some years ago a friend of mine, who held (note the past tense) that the reproduction of orchestral music couldn't sound life-like unless the volume in the home approached that in the concert hall, installed a 25-watt amplifier in his drawing room. He was delighted with it at first—or at any rate, thought that he was. He found, though, that those whom he had once invited for an evening's demonstration couldn't readily be persuaded to come again. My own feelings after half an hour's listening I can describe only as those of one who has been subjected to a mental and a physical bludgeoning. The owner of this third-degree instrument of torture confessed later that he had felt much the same way himself, but tried to think that he, not the volume level, was at fault.

Letters to the Editor

The Editor does not necessarily endorse the opinions of his correspondents

Suppressing Shaver Interference

SINCE writing my letter published in last week's *Wireless World* I have seen Mr. J. A. Yearsley's comments in the preceding issue. He suggests using a 0.01 mfd. condenser across the points of electric shavers (I take it that he means across the internal make-and-break contacts inside the shaver itself and not across the mains input to the shaver).

As the result of experiments conducted on five different makes of AC/DC interrupter-type shavers I have formed the opinion that that method of suppression is not entirely satisfactory. All the shavers caused very bad radio interference, and the connection of a 0.01-mfd. condenser across the make-and-break contacts caused the sparking to become worse and on two of the models was responsible for an actual increase in radio interference. One shaver showed a definite slowing down in running speed with the condenser connected. By increasing capacity to 0.1 mfd. sparking and radio interference were reduced, but the larger capacity seemed to slow down the motor of three of the models.

Referring to my accompanying sketch, the connection of a 0.01 or 0.1 mfd. at A

with and without a 0.01 mfd. condenser in series across the make-and-break of all five shavers. In two cases sparking and radio interference were reduced, but the results were best with connection made at point A. On the shorter wavelength direct radiation from the shaver motor seemed responsible for most of the interference.

My own opinion is that the shaver manufacturers should fit the correct value of capacity inside the shaver; my experiments would show that the various makes require different values. Let us hear what the experts have to say about it.

London, S.E.5. MARCUS GAMES.

Ceramic Insulators

WITH reference to the recent article by Dr. Hartshorn on ceramic insulating materials, I should like to be clear as to what he implies by stating that all ceramics have an affinity for water. Does he mean that surface condensation is present, that absorption into the body of the ceramic occurs, or what action is supposed to take place?

Ceramics are not peculiar in having films of moisture deposited on their surfaces by condensation, for, as Dr. Hartshorn points out, fused silica is liable to the same phenomenon. Moreover, it is impossible for absorption to take place into the body of the material by capillary action, since if the ceramic is properly vitrified the pores are closed.

It would be interesting to have Dr. Hartshorn's views on the points I have raised.

JOHN COCHRANE.

London, S.W.18.

IN reply to Mr. Cochrane, I would explain that my statement that ceramics have an affinity for water was meant to imply more than surface condensation. The experimental facts are that the power factor of the material is increased by the presence of water vapour, and that the increase persists to a considerable extent even when surface leakage is eliminated by an application of the guard-ring principle. I therefore conclude that absorption into the body of the ceramic occurs, as well as surface adsorption. I agree that capillary action is not likely to be the mechanism of the absorption, and I do not think that the mechanism has yet been explained. One must bear in mind that gases can diffuse through solids, that solid solutions are known, that adsorption may occur at internal surfaces of discontinuity, and that such surfaces are likely to exist between the crystalline and glassy components of a ceramic. I am inclined to the view that some such process is

Five-metre DX

NOTTINGHAM AMATEURS HEARD IN LONDON

DURING the early part of last week abnormal conditions obtained on the five-metre amateur waveband, and signals from distances in excess of 100 miles were being heard in London and the Southern Counties. Unfortunately, the beginning of this good spell was missed, but during the evening of May 31st and June 1st last exceptionally strong telephony signals were picked up from G6CW and G8JV, both stations being located in or near Nottingham.

G6CW was heard working with G2MV, the latter station being in Old Coulsdon, Surrey, and on this occasion G6CW's telephony was as strong and as steady as the writer usually hears from stations only about five miles distant. G8JV was also very strong but less reliable than G6CW.

On June 1st last and at about 10.15 p.m. BST marked fading and flutter were noticed, signals peaking to R8 and later fading to almost inaudibility. Half an hour later more settled conditions obtained by signals were very much weaker, and only CW communications would have been possible.

No signals were heard from these stations on June 2nd and 3rd, but on June 4th communication was effected with G6CW at 10.15 p.m. when signals were RST559 in both directions. On this occasion slow and deep fading was noticed.

These abnormal conditions occur from time to time and do not seem to be related in any way with the seasons.

G2MC.

The Wireless Industry

RADIO CLEARANCE, 63, High Holborn, London, W.C.1, are agents for the McMurdo Silver Communication receiver described in our issue of May 18th.

Modified versions of the G.E.C. DC/AC Touchtune 5, AC Touchtune 5 Radiogram, AC Selectalite 6, and Fidelity All-Wave Super 10, have been prepared for use in schools and have been approved by the Central Council for School Broadcasting. An extra charge of 10s. 6d. is made for these special models.

Two new catalogues of Dubilier condensers (No. C439) and resistances (No. R339) have just been issued. They are comprehensive and in addition to full electrical data and dimensions contain many interesting constructional sketches and performance curves.

The illustrated leaflets describing the loud speakers, microphones, amplifiers, etc., made by Gramplan Reproducers, Ltd., Kew, Surrey, have now been collected in catalogue form for handy reference.

We have received from the Miles Reproducer Co., Inc., 812, Broadway, New York, a technical bulletin on the new Model BB "Film-graph" recorder employing an indented sound track.

Philips Lamps, Ltd., have introduced new versions of their "MotoRadio" car radio receivers in which improvements have been made in performance, appearance and ease of installation. The price of the single unit models (Type 268V for 6 volts and Type 269V for 12 volts) is 13½ guineas, and of the *de Luxe* models with separated loud speakers, 15½ guineas.

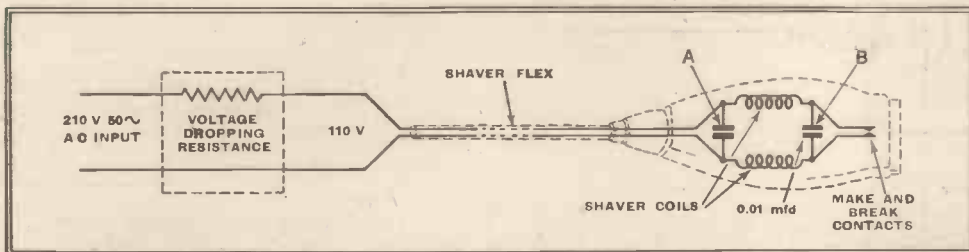

instead of B resulted in a really useful reduction of interference without any adverse effect on motor efficiency.

The next experiment tried was the connection of a resistance of about 5,000 ohms

involved, and I hoped that my phrase "affinity for water" would be sufficiently wide to cover all such processes.

L. HARTSHORN.

Teddington, Middlesex.

Recent Inventions

DIRECTION FINDERS

THE bearing line BX of a distant beacon transmitter B is indicated automatically by a frame aerial mounted on an aeroplane P and maintained in constant rotation at a speed of, say, 20 revs. per second. A contact on the aerial shaft is arranged to close a circuit each time the frame passes through a fixed datum line, say the fore-and-aft line FA of the aeroplane on which the direction finder is carried. The circuit is maintained closed until the frame passes through the critical point of minimum signal strength, whereupon it is automatically opened. A current accordingly flows during a period of time which is determined by the angle W between the fore-and-aft line FA of the craft and the bearing line BX of the distant transmitter.

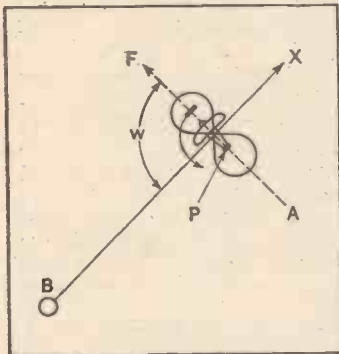

System of automatic DF for aircraft.

The resulting series of current impulses, recurring at a frequency of 20 per sec., are integrated to give a direct reading of the bearing angle W, relatively to the lubber line. The circuit producing the current impulses includes a rapid-action glow-discharge tube.

Soc. Anon. des Industries Radio-Electriques. Convention dates (France) March 10th and November 19th, 1937. No. 500006.

CATHODE-RAY TUBES

A CATHODE-RAY tube is designed to produce several separate electron streams from a multiple gun assembly, each stream being subject to independent control in its passage towards the fluorescent screen or photo-sensitive electrode in order to scan different lines of a picture simultaneously, or the same line in succession.

The several cathodes and control grids, each forming a gun unit, are mounted on one platform at the stub end of the tube. Each stream passes through a separate tubular anode which extends from the gun towards a common partition. This is provided with a corresponding number of apertures, and serves to accelerate the streams. Beyond it, each stream passes through an independent system of deflecting plates, to which the scanning voltages are applied. The arrangement ensures

Brief descriptions of the more interesting radio devices and improvements issued as patents will be included in this section.

that an equal accelerating field is applied to each stream, and, at the same time, effectively screens each stream, so as to prevent undesirable interaction between them.

Standard Telephones and Cables, Ltd. (assignees of M. S. Glass and D. A. S. Hale). Convention date (U.S.A.), May 20th, 1937. No. 500005.

AIRCRAFT DF

A CATHODE-RAY tube is used to give the pilot a visual indication of his position relative to the correct or centre-line course when flying along a radio beam. Two overlapping beams mark out the flying track, one being modulated with dots and the other with dashes. When either predominates the pilot knows that he is off his course, whilst along the centre line both signals come in at equal strength and merge into a continuous note, which is heard in the headphones P.

For the visual indication, the received signals are applied to a phase-splitting circuit CR shunted across the tuned anode circuit of the valve V. The two out-of-phase components are applied to the deflecting plates D, D1 of a cathode-ray tube T, and produce circular traces on the fluorescent screen. The radius of each circular trace is determined by the relative strength of the signal, though the brightness of the trace is always slightly greater for the dash than for the dot. The indication at (a), for instance, shows that the

machine is on the "dash" side of the centre line, that at (b) indicates that it is on the "dot" side, whilst that at (c), where both circles merge together, shows that the machine is flying "on course" down the centre of the beam.

Marconi's Wireless Telegraph Co., Ltd., and C. S. Cockerell. Application date, August 7th, 1937. No. 500359.

NON-FADING TRANSMITTING AERIALS

WHEN transmitting from a vertical wire or "mast" aerial it is found that fading can be prevented by so energising the aerial that the standing-wave system set up along it is slightly more than the full half-wave, say, 190 degrees instead of 180 degrees. In other words, the current distribution over a short part of the lower section of the aerial is arranged to be in opposite phase to that in the upper section. This helps to counterbalance the upward tilt of the radiated field, and so cuts down the so-called space wave which is the primary cause of fading.

The invention is concerned with ways and means for securing this result. For instance, one or more horizontal or inclined wires are arranged just above the lower end of the aerial to form a capacity "loading" of adjustable value, the feed line being connected at the point where these wires join

the aerial. In addition, a capacity "top" of folded wires is provided at the upper end of the aerial.

Marconi's Wireless Telegraph Co., Ltd., and S. Aisenstein. Application date, August 7th, 1937. No. 500360.

TUNING OF CAR RADIO

THE tuning knob and indicator are usually mounted on the dashboard of the car, whilst the set

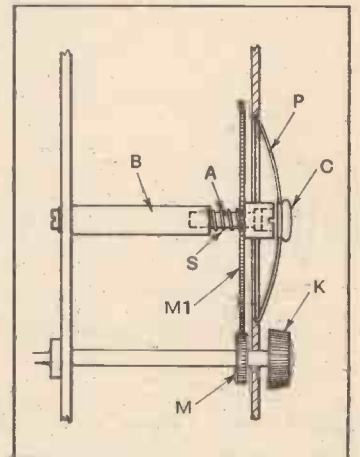

Compensating for backlash in car-radio tuning.

itself is located some distance away, the movements of the tuning knob being transmitted to the usual ganged condenser through a flexible shaft. In such an arrangement some degree of backlash is likely to occur, and the invention describes an easy method of correcting it.

As shown, the tuning knob K is geared through a wheel M with a second gear wheel M1, which turns on a spindle A mounted in a stub shaft B. A spring S normally keeps the two wheels M, M1 in gear, but permits sufficient axial movement of the wheel M1 to allow it to be disengaged when necessary. The indicator needle is mounted on the spindle A and is viewed against a fixed scale through a transparent coverplate P. To correct for backlash, a friction cap C is removed when the set has been tuned to a known station, and a screwdriver is inserted and pressed inwards to disengage the wheel M1. The spindle A can then be turned to bring the indicator needle accurately into line with the position of the station as marked on the scale.

E. K. Cole, Ltd., and H. G. Jarvis. Application date, September 22nd, 1937. No. 500305.

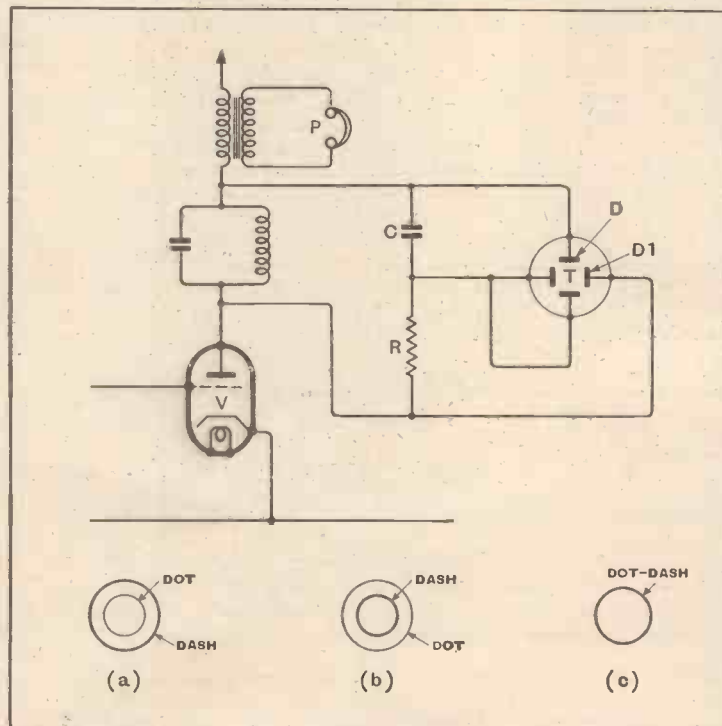

Use of a cathode-ray tube to give visual indication in aircraft DF system.

The British abstracts published here are prepared with the permission of the Controller of H.M. Stationery Office, from specifications obtainable at the Patent Office, 25, Southampton Buildings, London, W.C.2, price 1/- each.



PREMIER 3-60 WATT AMPLIFIERS

A NEW RANGE OF 7 HIGH FIDELITY PA AMPLIFIERS

Designed along the most modern lines and incorporating the very latest developments in radio technique, these amplifiers can be relied upon to give a continuous dependable performance.

All models up to 15 watts can be purchased in Kit form if desired, with the necessary straightforward diagrams and wiring instructions.

The 6-, 8-10 and 15-watt systems incorporate the new Premier Matchmaker Output Transformer, enabling any single or combination of speakers to be used.

Two separate input channels are provided which can be mixed at any level. Built-in Pre-Amplifiers ensure that

the gain is sufficient for any low-level crystal or velocity microphone.

The actual gain of the 6- and 15-watt units is over 100 decibels. A Tone Control is provided in all models, permitting compensation for varying acoustical conditions.

The 3-watt A.C. Amplifier has provision for energising a 2,500 ohm field speaker.

All Amplifiers can be supplied with Matchmaker Modulation Output Transformers at the same price and are designed for 200-250 volt mains (A.C. Models 40-100 cycles).

3-WATT A.C.	KIT with valves	£2.0.0	COMPLETE wired and tested	£2.15.0
3-WATT A.C./D.C.	KIT " " "	£2.0.0	COMPLETE " " "	£2.15.0
6-WATT A.C.	KIT " " "	£5.5.0	COMPLETE " " "	£6.0.0
8-10 WATT A.C./D.C.	KIT " " "	£4.10.0	COMPLETE " " "	£5.5.0
15-WATT A.C.	KIT " " "	£5.15.0	COMPLETE " " "	£7.0.0

Black Cracked Steel Cabinet (as illustrated) 15/- extra

- ★ Frequency Response (A.C. models) 30-11,000 cycles.
- ★ Negative Feed-back in all A.C. Models.
- ★ Resistance Coupled throughout.
- ★ Beam Power Output.
- ★ Octal Valves (International base).
- ★ Entirely British Made.

THE NEW PREMIER SELF-POWERED R.F. TUNING UNIT

Incorporating a Var. Mu Pentode Amplifier followed by a power grid detector. Designed for high-fidelity reception. Wave range 200-560 and 800-2,000 metres. Complete with valves £4.9.6

Have you had our 90 page 1939 Catalogue, Data Handbook and Valve Manual price 6d.
Deferred terms available.

30-60 WATT A.C. AMPLIFIERS

are designed to cover as wide a utility range as possible. Housed in a steel case, the 6-stage circuit gives an undistorted output of 30 watts. Two additional beam power valves, for which sockets are already wired in circuit, enable the output to be increased to 60 watts. Alternative power supplies are available in steel cases to match the amplifier. Model A30 provides all necessary power for the 30-watt, and A60 for the 60-watt Amplifier. The 30-watt outfit can be increased to 60 watts at any time by substituting the A60 power supply for the A30. Three separate input channels, two of which can be mixed at any level, are provided. The Class AB1 output stage has negative feedback applied, enabling unusually high quality to be obtained. Carefully chosen component values and the use of resistance coupling throughout result in a flat response curve of from 30 to 11,000 cycles within 2 dB. The high level input channel has a gain of over 100 dB.

COMPLETE AMPLIFIER, with separate 30-watt Power Pack and 7 valves, in black crackle finish steel case	12 gns.
COMPLETE AMPLIFIER, with separate 60-watt Power Pack, and 9 valves	15 gns.

PREMIER RADIO CO.,

ALL POST ORDERS TO: JUBILEE WORKS, 167, LOWER CLAPTON RD., LONDON, E.5
CALLERS TO: JUBILEE WORKS *Amherst 4723* or 169, FLEET STREET, E.C.4 Central 2833
or 50, HIGH STREET, CLAPHAM, S.W.4 *Macaulay 2381.*

THE WIRELESS ENGINEER

MONTHLY 2s. 6d. NET

Subscription
32s. per annum, post free.

The Journal of Wireless Research and Progress

"THE WIRELESS ENGINEER" is published in the interests of professional wireless engineers, educational authorities, students, and all those who are intimately associated with wireless development.

A valuable and unique feature consists of a monthly summary, under the title of Abstracts and References, of all important articles appearing in technical wireless publications in all languages throughout the world.

J. LIFFE & SONS LTD., DORSET HOUSE, STAMFORD STREET, LONDON, S.E.1.

Mention of "The Wireless World," when writing to advertisers, will ensure prompt attention.

GALPINS ELECTRICAL STORES

TERMS: Cash with Order or C.O.D. Charges extra

75, LEE HIGH ROAD, LEWISHAM, LONDON, S.E.13

Telephone: LEE GREEN 5240

NEON TRANSFORMERS, input 200/250 volts 50 cycles 1-phase output, 10,000 volts 10 m/A., 12/6 each, post 1/-. Ditto, 7,000 volts 8 m/A., 10/-, post 1/-. Ditto, 5,000 volts 5 m/A., 7/6, post 1/-. (All brand new.)
THE "RAGON" MOVING COIL HORN SPEAKER UNITS, 15 ohm Speech Coil 6 volt fitted handle, 15 watts, 15/- each, post 1/6.
"MAGNAVOX" P.A. MOVING COIL SPEAKERS, 700 and 2,000 field, 15 ohm speech coil. Handle 30/35 watts with horn 42in. x 22in. flare (new in packing case), 67/6 each, C/f.
A.C. INDUCTION MOTORS, approx. 1/4 h.p., 1,420 r.p.m. 200/250 volts 50 cy. 1 ph. As new, 21/- each.
EX-NAVAL 1-VALVE BUZZER WAVEMETERS, 200/24,000 metres. Complete in solid teak case. Size: 15x10x8 (less valve). Turner unit enclosed in copper tank (Sullivan high note buzzer). Price, 7/6 each, C/forward. Not sent C.O.D.
EVERSHED EX-R.A.F. HAND DRIVEN GENERATORS, with 2 outputs 800 volts 30 m/A. and 6 volts 2 amps., 25/-, post 1/6.
VOLTAGE CHANGER AUTO TRANSFORMERS, 100/120 volts to 200/240 volts or vice versa, 250 watts, 17/6; 500 watts, 25/-; 1,000 watts, 37/6; 1,500 watts, 42/6 each. C/forward. All fully guaranteed.
MOVING COIL METER MOVEMENTS for recalibrating into multirange meters. Low m/A. deflection. 2 1/2-in. dial, 5/- each; 4-in. and 6-in. dial, 6/- each. Post 1/-. (Note: All these meters are by good makers—Elliott, E. Edgcombe, etc.)
ELECTRIC LIGHT CHECK METERS, 200/250 volts, 50 cy., 1 phase, 5 and 10 amps., 6/- each. P.F.
X-RAY TRANSFORMERS, by well-known makers, all fully guaranteed. 50 cycle mains, 40,000 volts, 10 m/A., £5. 68,000 volts, 20 m/A., £7 10s. 100,000 volts, 30 m/A., £10 10s. All carriage forward.
A.C. MAINS RELAYS, 230 volts, trip at 1/2 amp. A few also at 400 volts, 7/6 each. Post 0d.
EX-R.A.F. ROTARY CONVERTORS. D.C. to D.C. 12 volts input, 500 volts 75/100 m/A. output, brand new, 25/-, post 1/-. S.H. condition, 20/-, post 1/-. Also a few with damaged brush, gear windings O.K., 10/- each, post 1/-.
SPOT WELDING TRANSFORMERS, 220/240 volts, 50 cy. 1 phase input 1/2 to 5 volts at 1 1/2 kilowatts. Makers, Foster. 45/- C/F.
EX-G.P.O. GLASS TOP RELAYS, Type B. Useful as Keying Relays, 5/- each, post 0d. Also a few only that need points, which are easily fitted, 2/6 each, P/F.
MAINS SMOOTHING CONDENSERS. Philips 1 mf., 3,000 volt working, 5/- each, post free. Siemens, 4 mf., 1,500 v. test, 2/6 each. T.C.C. 4 mf. 300 v. A.C. wkg., 2/- each. Standard Telephone 1 mf., 400 v. wkg., 3 for 1/-, post 4d., or in lots of 100, 12/6, post 1/6. T.C.C. 2,000 mf., 12 v. wkg., 3/- each.

EX-R.A.F. DOUBLE WOUND GENERATORS, giving two outputs, 1,200 volts 100 m/A., and 10 volts 4 amps., 15/- each, post 1/6.
"EPOCH" SUPER CINEMA MOVING COIL SPEAKERS, 6 volt field (less cone), 15/-, C/F.
"STANDARD" TELEPHONE COPPER SCREENED 23 S.W.G. TELEPHONE WIRE, 100 yd. coils, 4/- All new.
ZENITH WIRE WOUND RESISTANCES (Vitroous) 5,000 ohm carry 170 m/A., 10,000 ohm 50 m/A., 2,500 ohm 170 m/A., 750 ohm 300 m/A., 255 ohm 500 m/A., 1/- each. Post 4d.
SILVERTOWN GALVANOMETERS, jewelled movement, very sensitive, 5/- each.
ZENITH VARIABLE RESISTANCES, 30 ohms carry 2 1/2 amps., 8/6 each.
DYNAMOS, all shunt wound and fully guaranteed, 220 volts 15 amps., £6 10s.; 220 volt 10 amp., £3; 100 volt 20 amps., £6 10s.; 80/90 volt 10 amps., £2 15s.; 25 volt 8 amps., 32/6.
SWITCHBOARD VOLTMETERS, Everett Edgcombe, etc., 6-in. dial, moving coil, 0 to 300 volts, 15/-; 0 to 500 volts, 17/6; A.C. 0 to 250 volts, 15/-.
STANDARD TELEPHONE MAINS TRANSFORMERS 200/240 volts input, 50 volt 8 amps., also 500 volts 150 m/A. output, 12/6 each.
"SULLIVAN" TRANSMITTING CONDENSERS, variable, in glass tank, 0005 mf., and 001 mf., 7/6 each, post 1/-.
STEEL CABINETS. Useful as Transmitting Racks. Size 40x17 1/2 x 24in., 12/6 each. C/F.
3,000 WATT AUTO TRANSFORMERS, 0 to 220 volts in steps of 10 volts. Useful as small arc welders. Fully guaranteed, 65/- each. C/F.
PHILIPS 10-WATT PRE-STAGE AMPLIFIERS, less valves (in good condition), 10/6 each. Post 1/6.
EX-G.P.O. PEDESTAL TELEPHONES WITH AUTOMATIC DIALS, 5/6 each. Post 0d. Telephone wall boxes, consisting of A.C. bell 2 mf. microphone transformer, 2/- each.
ERNEST TURNER & WESTON 2-in. dial moving coil milliampmeters, B.S. 1st grade 0 to 5 and 0 to 50, 10/6 each.
TELEGRAPH. Morse inker complete with tapping key and sounder, fitted platinum contacts in first class condition, £3 10s. Ditto, less tapping key, 50/- C/F. (The former is of later pattern.)
WESTINGHOUSE RECTIFIERS. L.T. 6 volt 2 amps. D.C. output, input 11 volts, in new condition, 10/- each.
"NEWTON" MOTOR GENERATORS, input 220 or 100 volt D.C. output, 500/750 volts 200 m/A. D.C. output, 30/- C/F. Ditto, input 16 volts, 8 amps. output, 35/- each. C/F.
D.C. MOTORS approx. 1/4 h.p., 50 volts shunt wound, 7/6, post 1/-.

WHETSTONE BRIDGE, 1 to 10,000 ohms with mirror scale galvo., in good condition, £5. C/F.
ELECTROSTATIC VOLTMETER, 0 to 2,500 volts, 3 1/2-in. scale, maker, Everett Edgcombe, £1 15s.
"WESTINGHOUSE" AUTOTRANSFORMER. 100/110 volts to 200/240 volts or vice versa, 1,000 watts. Brand new, 37/6 each, post 1/6.
FERRANTI SPEAKER OUTPUT TRANSFORMERS, Type "A," ratio 7 1/2 to 1, pri. D.C. resist. 900 ohms, impd. 12,500 to 30,000. Type "B," ratio 24.9 to 1, pri. D.C. resist. 14,000 to 20,000 ohm, impd. over 111,000. Sec. D.C. resist. 13 ohms on both types. In new condition, 4/- each, post free.
"WESTON" 2-in. dial A.C. voltmeters 0 to 250 volts, 12/3 each; moving coil 0 to 1 amp. 2-in. dial, 7/6.
ROTARY CONVERTOR 220 D.C. to 150 volt A.C. 50 cy. 1 ph. 600 watts, with starter and step-up transformer to 200/240 volts, £4 10s. C/F. Another 100 volt D.C. input 70 volts A.C. 50 cy. 1 ph. output at 250 volts, 40/- C/F.
EX-G.P.O. TELEGRAPH MORSE TAPPING KEYS, with the original contacts mounted on ebonite, 8/6 each post 0d.; or mounted on wood base, 6/6 each, post 0d.
EX-G.P.O. MORSE TELEGRAPH SOUNDERS, with the original contacts as new, 5/- each. P/F.
INSTRUMENT WIRE, 4 lb. reels of 20 G enamel, 6/-, P/F.; 15 lb. of 16 gauge enamel, 15/-, post 1/-; 7 lb. of 18 gauge D.C.C., 8/6, post 0d.; 7 lb. of 10 Gauge D.C.C., 10/-, P/F. All new wire.
A.C. INDUCTION MOTORS, all fully guaranteed, 1/2 h.p. 2,800 r.p.m. with starter, 60/-; 1 h.p. Double Spindle 1450 without starter, 50/-; 2 h.p. Double Spindle 1450 r.p.m., complete with starter, £5. All for 200/250 volts 50 cy. 1 phase.
"MACKIE" ROTARY CONVERTORS, 80/120 volts D.C. input at 11 amps. Output 80/120 volts 6 1/2 amps. 1,000 cycles, £4 10s. each. C/Forward.
LARGE SCALE MOVING COIL MILLIAMM METERs, 0 to 10 and 100 m/A., 7in. dial, 25/-; 0 to 15 m/A., 10in. dial, 25/-; 0 to 15 m/A., 4in. dial, 15/-; 0 to 10 m/A., 6in. dial, 17/6; 0 to 18 m/A., 5in. 15/-; 0 to 3,000 m/A., hot wire 5in. dial, 22/6; a Marconi Moving Coil, 250 to 1,500 voltmeter, 7in. dial, 25/-. All first grade meters.
"PHILIPS" MAINS TRANSFORMERS, 200/240 volts input, 2,000/0/2,000 volts 200 m/A. output, with two L.T.'s, 22/6 each. C/Forward.
SMALL SPOT WELDING TRANSFORMERS, 200/230 volts input, 3-4 1/2 and 7 1/2 volts at 150/300 amps. output, 17/6. C/Forward.
MOVING COIL RECORDING VOLTMETER, complete with inking mechanism in working order, 35/- C/F.

An inexpensive PRECISION Instrument

The D.C. AVOMINOR

Regd. Trade Mark.

ELECTRICAL MEASURING INSTRUMENT

This instrument provides precision testing facilities at a truly modest cost. Incorporating a fully jewelled moving-coil movement and a 2 1/2-in. scale, it permits accurate readings of milliamps., volts and ohms, with ranges adequate for the majority of normal circuit, battery and resistance tests. The total resistance of the meter is 100,000 ohms; full scale deflection of 300v. or 600v. is obtained for a current consumption of only 3mA. and 6mA. respectively.

In case, complete with leads, interchangeable crocodile clips and testing prods; and with comprehensive instruction booklet.

45/-

DEFERRED TERMS IF DESIRED

13 RANGES

CURRENT	
0-6 milliamps	
0-30 milliamps	
0-120 milliamps	
VOLTAGE	
0-6 volts	
0-12 volts	
0-120 volts	
0-240 volts	
0-300 volts	
0-600 volts	
RESISTANCE	
0-10,000 ohms	
0-60,000 ohms	
0-1,200,000 ohms	
0-3 megohms	

BRITISH MADE

• Write for fully descriptive pamphlet

Sole Proprietors & Manufacturers:
 The Automatic Coil Winder & Electrical Equipment Co., Ltd.,
 Winder House, Douglas Street, London, S.W.1. 'Phone: Victoria 3404/7

Third Edition of

WIRELESS DIRECTION FINDING

By R. KEEN, B. Eng.

A BOOK OF INSTRUCTION AND REFERENCE FOR ENGINEERS, TECHNICIANS, TELEGRAPHISTS AND OTHERS ENGAGED OR INTERESTED IN THE USE OF DIRECTIVE WIRELESS TELEGRAPHY FOR THE NAVIGATION OF SHIPS AND AIRCRAFT.

Deals with the principles of Wireless Direction Finding and gives an account of the circuits and apparatus used in its application to navigation. The Adcock Aerial has a separate chapter covering its principles, installation and performance. Shore, Ship and Aircraft installations, as well as a special section on the choice of a suitable site for the Aircraft Ground D.F. with Adcock Aerials are included.

Also useful references to a selected list of some 600 of the more important contributions to the literature of D.F.

800 pages
 550 illustrations
 25/- net
 By post 25/9

From leading Booksellers or direct from the Publishers:
 ILIFFE & SONS LTD., DORSET HOUSE, STAMFORD STREET, LONDON, S.E.1

Mention of "The Wireless World," when writing to advertisers, will ensure prompt attention.

CLASSIFIED ADVERTISEMENTS

NOTICES

THE CHARGE FOR ADVERTISEMENTS in these columns is

12 words or less, 3/- and 3d. for every additional word.

Each paragraph is charged separately and name and address must be counted.

SERIES DISCOUNTS are allowed to Trade Advertisers as follows on orders for consecutive insertions, provided a contract is placed in advance, and in the absence of fresh instructions the entire "copy" is repeated from the previous issue: 13 consecutive insertions 5%, 26 consecutive, 10%; 52 consecutive, 15%.

ADVERTISEMENTS for these columns are accepted up to FIRST POST on MONDAY MORNING (previous to date of issue) at the Head Offices of "The Wireless World," Dorset House, Stamford Street, London, S.E.1, or on SATURDAY MORNING at the Branch Offices, 8-10, Corporation Street, Coventry; Guildhall Buildings, Navigation Street, Birmingham, 2; 260, Deansgate, Manchester, 3; 26a, Renfield Street, Glasgow, C.2.

Advertisements that arrive too late for a particular issue will automatically be inserted in the following issue unless accompanied by instructions to the contrary. All advertisements in this section must be strictly prepaid.

The proprietors retain the right to refuse or withdraw advertisements at their discretion.

Postal Orders and Cheques sent in payment for advertisements should be made payable to LILFFE & SONS Ltd., and crossed & Co. Notes being untraceable if lost in transit should not be sent as remittances.

All letters relating to advertisements should quote the number which is printed at the end of each advertisement and the date of the issue in which it appeared.

The proprietors are not responsible for clerical or printers' errors, although every care is taken to avoid mistakes.

ARMSTRONG'S
NEW HEADQUARTERS

We are the Pioneer Manufacturers of Chassis, and every purchaser of an ARMSTRONG gets the full benefit of our years of experience, backed by the guarantee of a well-established organisation.

The vast number of *Wireless World* readers who regularly use our sets know that ARMSTRONG stands for quality performance coupled with consistent reliability.

We do not wish to appear boastful, but the above are facts which can be confirmed.

Send for Illustrated Catalogue of our full range, which includes the following outstanding chassis.

MODEL RF96 Price £8.0.0
6-V. ALL-WAVE RADIOGRAM CHASSIS
Complete with Matched M.C. Speaker.

Incorporating R.F. Amplifier. 3 wavebands, 17.9-50, 200-550, 1,000-2,000 m., 3 stages of A.V.C., corrected 3½ watts output.

MODEL AW93PP . . . Price £10.10.0
9-V. ALL-WAVE RADIOGRAM CHASSIS

3 wavebands, R.F. Pre-Amplifier, 3 stages of A.V.C. and 8 watts R.C. coupled Triode P.P. output.

MODEL AW125PP . . Price £17.17.0
12-V. ALL-WAVE RADIOGRAM CHASSIS

5 wavebands, 12-550 continuous, 1,000-2,000 m., R.F. Pre-Amplifier, 2 I.F. stages with Variable Selectivity, Manual R.F. gain control and 10 watts R.C. coupled Triode P.P. output.

ARMSTRONG MANUFACTURING CO.,
WALTERS ROAD, HOLLOWAY, LONDON, N.7
(Adjoining Holloway Arcade.)

Telephone: NORTH 3213.

BOOKS ON WIRELESS

Write for complete list to

Iliffe & Sons Ltd., Dorset House, Stamford St., London, S.E.1
W.W.1

Just Between
Ourselves

This is the basis upon which we conduct our business. No "third party" enters into it!

When you purchase Radio Apparatus on L.R.S. Convenient Terms the whole transaction is strictly confidential from beginning to end—a direct one—"just between ourselves."

The process is simple. You order what you want, we open an account in your name, you settle it in equal monthly payments. So why pay cash!

Whatever you want in Radio we can supply—and we specialise in quality apparatus.

May we have the pleasure of quoting for your requirements?

This entails no obligation, of course!

Estd. - 1925 THE Phone NATIONAL 6828

LONDON RADIO SUPPLY
COMPANY
11-OAT LANE NOBLE ST LONDON EC2

NUMBERED ADDRESSES

For the convenience of private advertisers, letters may be addressed to numbers at "The Wireless World" Office. When this is desired, the sum of 6d. to defray the cost of registration and to cover postage on replies must be added to the advertisement charge, which must include the words Box 000, c/o "The Wireless World." All replies should be addressed to the Box number shown in the advertisement, c/o "The Wireless World," Dorset House, Stamford Street, London, S.E.1. Readers who reply to Box No. advertisements are warned against sending remittances through the post except in registered envelopes: in all such cases the use of the Deposit System is recommended, and the envelope should be clearly marked "Deposit Department."

DEPOSIT SYSTEM

Readers who hesitate to send money to advertisers in these columns may deal in perfect safety by availing themselves of our Deposit System. If the money be deposited with "The Wireless World," both parties are advised of its receipt.

The time allowed for decision is three days, counting from receipt of goods, after which period, if buyer decides not to retain goods, they must be returned to sender. If a sale is effected, buyer instructs us to remit amount to seller, but if not, seller instructs us to return amount to depositor. Carriage is paid by the buyer, but in the event of no sale, and subject to there being no different arrangement between buyer and seller, each pays carriage one way. The seller takes the risk of loss or damage in transit, for which we take no responsibility. For all transactions up to £10, a deposit fee of 1/- is charged; on transactions over £10 and under £50, the fee is 2/6; over £50, 5/-. All deposit matters are dealt with at Dorset House, Stamford Street, London, S.E.1, and cheques and money orders should be made payable to Iliffe & Sons Limited.

SPECIAL NOTE.—Readers who reply to advertisements and receive no answer to their enquiries are requested to regard the silence as an indication that the goods advertised have already been disposed of. Advertisers often receive so many enquiries that it is quite impossible to reply to each one by post. When sending remittances direct to an advertiser, stamp for return should also be included for use in the event of the application proving unsuccessful.

NEW RECEIVERS AND AMPLIFIERS

R.

C.

TELEPHONE: Holborn 4631.

RADIO CLEARANCE, Ltd., 63, High Holborn, W.C.1, by offering brand new receivers, maintain their reputation as the leading Mail Order House for surplus radios.

BRITISH Belmont 8-valve Plus Magic Eye All-wave A.C. Superhet Chassis, 4 wave bands, 2 short medium and long, fitted latest Mullard octal base American type valves. Brief specification: Short wave 6-18 metres (covers television sound), short wave 2, 18-50 metres, medium band 200-550 metres, long 900-2,000 metres; valve combination 6K7 Pre H.F., 6J7 oscillator, 6J7 mixer, 6K7 I.F., 6Q7 (DDT) detection, A.V.C. and first L.F., two 6F6s, parallel output, 5Y3 rectifier, plus 6G5 Magic Eye visual tuning, handsome dial, station names etched on glass, controls 2-speed tuning, volume and on-off, combined variable tone control and selectivity switch, wave change plus gram. switch; size of chassis 13½in. x 10in. x 3in.; supplied complete with valves, escutchion, knobs, but less speaker, £5/19/6 each; complete receiver in handsome walnut cabinet, details as above, complete with speaker, £7/7.

DECCA 6-valve 3-waveband Battery Chassis, fitted complete with Mazda and Osram valves, QFP output; these chassis give a sparkling performance on all wavebands, and are the product of a well-known manufacturer, complete with valves, £3/3 each; complete in De Luxe walnut cabinet, chromium plated surrounds, £7/17/6.

ALL the Above Fitted Ring Valves Throughout.

SEE Our Advertisement under Components.

RADIO CLEARANCE, Ltd., 63, High Holborn, W.C.1
Telephone: Holborn 4631. [8520]

*

DEGALLIER'S "Challenge Radio Corporation."

SEND 2d. stamp for Handsome Illustrated Catalogues Telling of our Superb Range of Receivers; direct public-sales policy (saves you 40%), most exceptional value on the market, from a T.R.F. Midget at £3/5 to a 19-valve general purpose receiver, 6 bands, with two P.A. speakers, at 30 gns.; 6-page brochure of *Wireless World* report on this set is available; car radio; any known American valve, all 5/6 each; also American P.A. speakers, cabinets, and the Challenger 6-valve A.C. tuning unit, 5 bands 6-10, 12.8-50, 65-200, 190-550, 900-2,000 metres. Hours business 11 a.m. until 9.30 p.m.

DEGALLIER'S 31, Craven Terrace, London, W.2.
Paddington 6492. Nearest point Lancaster Gate Tube Station. [8515]

HOWARD 438 8-tube 4-band Communication Receiver. 7-550 metres, with matched crystal and R. meter; £19/19.—Superadio, Dantzic St., Manchester. [8510]

NEW RECEIVERS AND AMPLIFIERS

ARMSTRONG Co.—After many years at our old premises at Camden Town we have removed to a new building in Warlters Rd., Holloway, N.7 (see displayed advertisement).

ARMSTRONG Amplifier Division Has Removed to New Premises at 94, Camden Rd., N.W.1. Enquiries for High Fidelity amplifiers and simple feeder units should be made to this address. Catalogue of this apparatus will be forwarded free to those interested.

ARMSTRONG Co. (Amplifier Division), 94, Camden Rd., N.W.1. [8518]

COME and Hear the Empire's Finest Radio, 1939 "Homeland 12," offered at a sensational low price including speaker; 32 gns. only; designed on technical merits alone to meet the public's honest requirements; built to give radio performance, not "sales effect."

HIGH Class Servicing by Expert Engineers; write, call or phone.

THE ANGLO-AMERICAN RADIO (AND MOTORS). Ltd., 59, New Oxford St., W.C.1. Phone: Temple Bar 3231. [8560]

RECEIVERS AND AMPLIFIERS
CLEARANCE, SURPLUS, ETC.

AMAZING Offer.—Famous 7-valve push button 1939 models, in makers' sealed cartons, listed 13½ gns.; £5/19/6.—Shippers, 18, Corporation St., Manchester. [0636]

Wanted

WANTED.—H.F. Radio Unit for Sound Sales 4-12 watt W.W. quality amplifier; also Piezo pick-up.—Longridge, 1, Rex Avenue, Ashford, Middlesex. [8532]

USED SETS FOR SALE

HALFORD

PHANTOM XV Halford Radio, all-wave, chromium De Luxe chassis, 1939 model, as new, cost 55 gns.; £20.—Snow, Sutton Cottage, Godalming, Surrey. [8540]

HALLICRAFTER

£15.—HALLICRAFTER Sky Chief Receiver, list price £25, two months old.—Pritchard, 42, Green Lane, Purley. [8533]

MISCELLANEOUS

A NUMBER of Reconditioned Sets in Good Order; from £5 upwards.—Halford Radio, 31, St. George St., W.1. [0617]

Wanted

WANTED, cheap Murphy D.28 Console; state if needs repair.—Box 9974, c/o *The Wireless World*. [8521]

CAR RADIO

1939 Models from 4½ gns.; 6 new car aeri-als, from 9/6; trade enquiries solicited; lists free.—Shippers, 18, Corporation St., Manchester. [0622]

FINEST American Twin Running-board, Aerials, completely rubber covered, maximum signal pick-up, minimum noise, easy mounting, now only 17/6 pair complete; handsome chromium roof aeri-als, to mount straight or "vee," complete, 15/-; immediate despatch, carriage paid; cash with order or c.o.d.

WIRELESS SUPPLIES UNLIMITED, Essex House, Stratford, E.15, Maryland 3191. [0577]

PUBLIC ADDRESS

VORTEXION P.A. Equipment. IMITATED, but unequalled.

WE Invite You to a Demonstration.

A.C.-D.C. Dance Band Amplifier, 10 watts output, complete in case, with moving coil microphone, speaker and cables, weight 22lb.; 12 gns.

A.C.-20 15-20-watt Amplifier, 38-18,000 cycles, independent mike and gram, inputs and controls, 0.037 volts required to full load, output for 4, 7.5, and 15 ohms speakers or to specification, inaudible hum level; ready for use; 8½ gns., complete.

C.P. 20, 12-volt battery and A.C. mains model, as used by R.A.F., output as above; 12 gns.

A.C.-20, in portable case, with Collaro motor, Piezo pick-up, etc., £14; C.P.20 ditto, £17/17.

50-WATT Output 6L6s, under 60-watt conditions, with negative feed back, separate rectifiers for anode screen and bias, with better than 4% regulation, level response, 20-25,000 cycles, excellent driver, driver transformer, and output transformer matching 2-30 ohms impedance electronic mixing for mike and pick-up, with tone control, complete with valves and plugs; £15.

COMPLETE in Case, with turntable B.T.H. Piezo pick-up and shielded microphone transformer; £20.

80-WATT Model, with negative feed back; £25, complete.

120-WATT Model, with negative feed back; £40, complete.

250-VOLT 250 m.a. Full Wave Speaker, field supply unit; 25/-, with valve.

ALL P.A. Accessories in Stock; trade supplied.

VORTEXION, Ltd., 182, The Broadway, Wimbledon, S.W.19. Phone: Lib. 2814. [8241]

"PARTRIDGE P.A. Manual," standard handbook on electro-acoustics, amplifiers, and audio circuits; price 2/6 (free to trade).

"PARTRIDGE Amplifier Circuits," describes many modern constructional amplifiers, 2w. to 45w. output, battery, A.C.-D.C., etc.; price 2/- (no free copies).

PARTRIDGE, N., B.Sc., A.M.I.E.E., King's Buildings Dean Stanley St., London, S.W.1. [0630]

QUALITY Amplifiers and Microphone Equipments for Hire or Permanent Installation.—Harmony House, 116, Cambridge Rd., Southport. [8505]

ALEXANDER BLACK, Ltd., pioneers of hiring microphone amplifying equipment since 1928. Booklet on request.—55, Ebury St., S.W.1. Sloane 6129. [0598]

PUBLIC Address Contractors Can Hire P.A. Vans, loud speakers, microphones and equipments of all types from Hire Dept., Grampian Reproducers, Ltd., Kew Gardens, Surrey. Tel.: Richmond 1175-6-7. [0618]

RIBBON Microphone, 7 models, from £3/19/6, list free; 15-watt, high gain, high fidelity, 4-stage amplifier for ribbon microphones, £12/10; 30-watt ditto, £18.—Holiday and Hemmerding, Ltd., 74, Hardman St., Manchester. [8475]

NEW MAINS EQUIPMENT

ALL Transformers at Last Week's Prices.

VORTEXION, Ltd., 182, The Broadway, Wimbledon, S.W.19. Phone: Lib. 2814. [8558]

TRANSFORMERS for the C.R. Oscilloscope, 25/- each; trade enquiries invited.—W. A. Davies' A.M.I.W.T. 6, Oxford St., Newcastle-on-Tyne, 2. [8542]

NEW LOUD-SPEAKERS

SINCLAIR Speakers for All Types.—Alma Grove, Copenhagen St., N.1. [0603]

SAVE Pounds.—1½d. stamp for list British and American P.A. Speakers.—Degallier's, 31, Craven Terrace, London, W.2. [8554]

BAKER'S New Corner Horn Speakers, triple cone conversions, from 29/6; and surplus speaker bargains.—Details free from Bakers Selhurst Radio, 75, Sussex Rd., South Croydon. [8512]

LOUD-SPEAKERS

SECOND-HAND, CLEARANCE, SURPLUS, ETC.

VAUXHALL UTILITIES, 163a, Strand, W.C.2.—Rola, G12 P.M. speakers, 62/6; G12 energised, 50/-; with transformers, brand new. [8555]

3,000 Speakers from 5/6 each, P.M. and energised, 4in. to 14in., including several Epoch 18in.—Sinclair Speakers, Alma Grove, Copenhagen St., N.1. [0591]

LOUD-SPEAKER CONVERSIONS

EPOCH Domino Loudspeakers can Now be Converted to the Famous "NEW" Super Cinema Speaker with 14in. Cone, replacement for all Epoch speakers, also output transformers; a genuine Epoch hand-made cone for any speaker.

HALFORD DISTRIBUTORS, Ltd., 31, St. George St., W.1. Sole manufacturers of Epoch loudspeakers and the famous Halford Phantom radio set. [0632]

VORTEXION 50 W AMPLIFIER £15 in Chassis Form

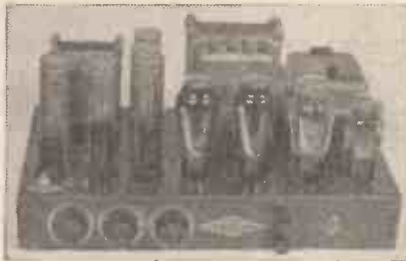

VORTEXION, LTD., are making a new 50 W amplifier which is offered at £15 as a chassis with valves and plugs, or at £20 complete in black leatherette-covered, cabinet with Collaro turntable, piezo-electric pick-up and shielded microphone transformer.

A pair of matched 6L6's with 10 per cent. negative feed-back is fitted in the output stage, and the separate HT supplies to the anode and screen have better than 4 per cent. regulation, while a separate rectifier provides bias.

The 6L6's are driven by a 6F6 triode connected through a driver transformer incorporating feed-back. This is preceded by a 6N7, electronic mixing for pick-up and microphone. The additional 6C5 operating as first stage on microphone only is suitable for any microphone. A tone control is fitted, and there is an eight-section output transformer whereby any output from 2 to 30 Ω or 4 to 60 Ω to choice may be matched and yet deliver the full response (20-18,000 C/S) to the loud-speakers.

Vortexion, Ltd., 182 The Broadway, Wimbledon, S.W.19. Phone: LIBerty 2814.

For PROMPT DELIVERY of High Quality

LOUDSPEAKERS, LOUD-SPEAKER CONES, LOUD-SPEAKER COMPONENTS, TRANSFORMERLAMINATIONS, TRANSFORMER HOUSINGS, TRANSFORMER WINDINGS, CHOKE WINDINGS, FIELD COIL WINDINGS, PERMANENT MAGNETS, PRESS TOOLS AND PRESSINGS, JIG BORING. AUTOMATIC SCREW MACHINE PARTS UP TO 2" DIAMETER.

Contractors to the Admiralty, War Office and Air Ministry.

Call on BRITISH ROLA LTD. MINERVA ROAD, PARK ROYAL, N.W.10. PHONE: WILLESDEN 4322-3-4-5-6

Pamphonic AMPLIFIERS Pamphonic Reproducers Ltd. (Associated with PYE Ltd.) 45, St. Pancras Way, London, N.W.1. Phone: EUSton 1727.

TRANSMITTING APPARATUS

A.C.S. RADIO, specialists in short-wave apparatus, communication receivers, including Hallicrafters, National and R.M.E. transmitting equipment, valves and components.—Send for free catalogue to A.C.S. Radio, 16, Gray's Inn Rd., W.C.1. Holborn 9894-5. G2NK, Technical Manager. [0550]

G5NI—The oldest and largest distributor of amateur equipment, transmitting and receiving; short-wave catalogue, 1½d.; G5NI 70-page Manual, 7½d., post free; authorised direct distributor for Collins, National, R.M.E., Thordarson, Hammerlund, Biley, Taylor, Eimac, etc., etc.—44, Holloway Head, Birmingham. [0531]

CABINETS

A CABINET for Every Radio Purpose.

CONVERT Your Set into a Radiogram at Minimum Cost; surplus cabinets from noted makers under cost of manufacture (undrilled); 30/- upwards; motors at wholesale prices.

"FIT-A-GRAM" Cabinet, 31 x 17 x 15; 21/- from 3/6.

UNDRILLED Table Console and Loud-speaker Cabinets, INSPECTION Invited; photos loaned to country customers.

H. L. SMITH and Co., Ltd., 289, Edgware Rd., W.2. Tel.: Pad. 5891. [0485]

CLEARANCE Sale! — Radiogram and television cabinets, prices slashed! 10 gns. worth for 50/1 5 gns. worth for 20/1.—Write, wire, phone or call, Cameo Co., 23, Denmark St., W.C.2. (Tem. 5900.) [8527]

DEGALLIER'S for the Finest Obtainable American Cabinets, Table, Console and Radio Grams; also Record Changers, 5 gns. Send 1½d. stamp for reprints from actual photographs.—Degallier's 31, Craven Terrace, Lancaster Gate, London, W.2. [8553]

DYNAMOS, MOTORS, ETC.

D.C.-A.C. Convertors, motors, all voltages, for sale and wanted.—Easco, 18w, Brixton Rd., S.W.9. [0558]

ALL Types of Rotary Convertors, electric motors, battery chargers, petrol-electric generator sets, etc., in stock, new and second-hand.

A.C.-D.C. Conversion Units for Operating D.C. Receivers from A.C. Mains, 100 watts output, £2/10; 150 watts output, £3/10.

WARD, 46, Farringdon St., London, E.C.4. Tel.: Holborn 9703. [0518]

RECORDING EQUIPMENT

ALL Recording Discs and Materials in Stock; tracker units, £4/7/6; recording motors, £3/17/6.—Write for further details, Will Day, Ltd., 19, Lisle St., W.C.2. [0595]

FEIGH Recording Sets are Within Reach of All; ball bearing gear box, worm drive traverse; records on any disc, Morse, speech or music; diamond cutter-pickup on tone arm, the set 37/6; 6in. blanks 3/3 doz.; 10in. discs, 7/- doz.—Electradix, 218 Upper Thames St., London, E.C.4. [0620]

VALVES

PREMIER RADIO Co.

SPECIAL Offer.—Continental mains valves, 4v. AC types, 5-pin only, AC/HL, AC/L, AC/P, AC/SG, AC/VMS, AC/HP, AC/VHP, 2/6 each; 20v. 18a. types, SG, Var. Mu. SG, Power, HF Pen., 2/- each; U.S.A. Types: 24, 30, 41, 39/44, 35/51, 55, 56, 57, 58, 71, 77, 85, 89, 2A5, 2A6, 2A7, 2B7, 6A7, 12Z3, 210, 250, all 2 for 3/-; on orders under 5/- add 6d. postage; please see our displayed advertisement on page 1.—Jubilee Works, 167, Lower Clapton Rd., London, E.5. Amherst 4723. [0637]

ALL Types of American Tubes in Stock of Impex and Arcturus makes at competitive prices.

WE Can Also Supply a Full Range of Guaranteed Replacement Valves for Any British non-ring, American or Continental type at an appreciably lower price.

SEND for Lists of These, and also electrolytic condensers, line cords, resistances, etc.

CHAS. F. WARD, 46, Farringdon St., London, E.C.4. Tel.: Holborn 9703. [0452]

AMERICAN, 2/9; 1,000 non-ring British, from 1/9; bargains galore; lists free.—Shippers, 18, Corporation St., Manchester. [0607]

METROPOLITAN RADIO SERVICE.—Special offer: American valves, in makers' cartons, 3/- each; Octals, 3/6 each; American valves, first grade, in all types; trade supplied.—1021, Finchley Rd., N.W.11, Speedwell 3000. [0436]

TEST EQUIPMENT

RESEARCH Engineer going abroad has quantity laboratory apparatus for immediate disposal, equipment by Cambridge, Sullivan, Turner, Ferranti, experimental test gear; list price exceeds £400; will sell complete at 50 per cent. cost.—Apply Box 24, c/o The Wireless World. [8537]

Wanted

WANTED.—"W.W." Modulated Test Oscillator.—Apply Box 23, c/o The Wireless World. [8536]

COMPONENTS

SECOND-HAND, CLEARANCE, SURPLUS, ETC.

PREMIER SUPPLY STORES.

PLEASE See Our Displayed Advertisement on page 1. [0488]

VAUXHALL UTILITIES, 163a, Strand, W.C.2.—Ask for free list; sheet aluminium, 12in. x 12in., 3/-; 12in. x 18in., 4/-.

VAUXHALL.—Hivac valves, all standard capacity bar-type condensers, trimmers, 2-gang, 6/6; 3-gang, 8/-.

VAUXHALL.—T.C.C. dry, 8 mid., 2/6; 600v. aluminium containers; T.C.C. 600v. dry, cardboard containers, 8 mid., 1/9. [8556]

COMPONENTS—SECOND-HAND, CLEARANCE, SURPLUS, ETC.

RADIO CLEARANCE, Ltd.,
63, High Holborn, W.C.1. Holborn 4631.

PRESS Button Assembly, comprising compact unit size 6in.x6in.x2in., complete with six press buttons and manual trimmer for balancing circuits, complete with ten silver mica capacitors; ideal for adapting existing receiver for press button tuning; 9/11 each.

SET of 4 Skeleton Type All-wave Coils (manufacturers type unshielded), comprising oscillator coil, wave trap, broadcaster aerial coil and short wave coil with circuit; 2/6 set of 4.

EARPHONES by Standard Telephones, 2,000 ohms resistance; 5/11 per pair.

AMERICAN Press Button Car Radios, 6- and 12-volt models, manual tuning plus 6 press buttons, medium wave only, 6 gns.; medium and long, £6/15.

CAR Aerials, running board type, 8/6; chromium roof type, 11/6.

T.C.C. New Range of Compact Electrolytic Condensers, as follows:—

T.C.C. 8 Mfd. Tubular Electrolytic, wire ends, 500 volt working, 600 volt surge; 1/6 each.

T.C.C. 8 Mfd. Midget, wire ends, size 2 1/2 in. x 1 1/4 in., 500 volt working, 600 volt surge; 1/6 each.

T.C.C. 8 plus 8 4-lead Midget Electrolytics, 500 volt working, 600 volt surge; 2/9 each.

T.C.C. 1 Mfd. Tubular, wire ends; 1/- each.

T.C.C. Bias Condensers:—50 mfd. 12 volt, 1/-; 25 mfd. 25 volt, 1/-; 25 mfd. 50 volt, 1/3; 50 mfd. 25 volt, 1/3; 50 mfd. 50 volt, 1/6.

WEARITE Mains Transformers, standard for the season and exclusive to us, made to strict electrical standards, wire end type, all windings centre tapped, screened primaries, tapped inputs, 200-250 volts, screw adjustment.

TYPE R.C.1, 250-0-250, 80 m.a. 4 volts 2.5 amp., 4 volts 4.5 amp.; 9/6 each.

TYPE R.C.2, 350-0-350, 120 m.a. 4 volts 2.5 amp., 4 volts 5 amp.; 11/- each.

TYPE R.C.3, 350-0-350, 150 m.a. 4 volts 2.5 amp., 4 volts 2 amp., 4 volts 5 amp.; 12/6 each.

R.C.4 500-0-500, 150 m.a. 4 volts 2 amp., 4 volts 2 amp., 4 volts 2.5 amp., 4 volts 5-6 amp.; 19/6 each.

TYPES R.C.1 and R.C.2 Drop Through Type, capped.

TYPES R.C.3 and R.C.4 Upright Mounting Type, fully shrouded.

WEARITE Auto Transformers, type R.C.5, fully shrouded, input 100-110 volts, output 200-250 volts, 100 watts; 12/- each.

PLESSEY Slow-motion Drives.

TYPE 1841-1125, size of dial 5in. square; 2/- each.

TYPE 1393, size of dial 4x5; 1/10 each.

TYPE 1510, size of dial 4x5; 1/10 each.

TYPE 2077, clock face dial, separate indications, size of dial 5x5. (R. and minute-hand type), geared; 4/6 each.

TYPE 2806, size of dial 8x3, overall height 8in.; 1/3 each.

TYPE 1825, size of dial 5 1/2 x 1 1/2; 1/3 each.

ALL Above With Plain Unprinted Scales Only.

CRYSTAL Pick-up, high grade American, bronze finish complete with arm; £1/5 each.

STANDARD Octal Base Valve Holders; 4d. each.

AMERICAN Valve Holders, best quality, 4-, 5-, 6-, and 7-pin; 3d. each.

CLIX 5-pin Chassis, 3d. each; Clix 7-pin chassis, 4d. each; Bulgin S.P.S.T. twist switch, 9d. each; Bulgin D.P.D.T. twist switch, 1/- each.

T.C.C. Paper Tubular Condensers, all sizes up to 0.1. 5d. each, 4/6 doz.; 0.25 ditto, 7d. each; 0.5, 10d. each.

POLAR N.S.F. 1 Watt Resistances; 3/4d. each, 3/- doz.; all sizes up to 2 meg.

MAINS Smoothing Chokes. Wearite unshrouded, fitted wire ends:—30 henry 80 m.a., 500 ohms, 7/6 each; 40 henry 150 m.a., 500 ohms, 10/6 each.

AMERICAN Valves.—Complete range of Raytheon 1st Grade stocked; competitive prices consistent with quality; write for lists.

LISSEN Valves, brand new, boxed, as follows:—H2, L2, 2/- each; BB.220A, 3/11 each; SGV, SG 215, 3/11 each.

RADIO CLEARANCE Bargains Continued in Third Column.

ELECTRADIX

ALWAYS GIVES EXCELLENT VALUE FOR MONEY

DIX-MIPANTA TEST METER
This is a wonderfully versatile, high-grade moving iron multi-range meter for service on A.C./D.C. jobs. No projecting terminals. RANGE ranges of volts: 0-7.5, 0-150, 0-300. Used for MILLIAMPS, reads 0-121 m.a. and 0-75 m.a. In black bakelite 19/6 case. Only 2 1/2 in. by 2 1/2 in.



The Dix-Mipanta

DIX-ONEMETER
The Dix-One meter with only 6 Terminals, but 50 Ranges, is a valuable instrument for laboratory work. It is of portable size to go in the pocket, but big enough to cover the whole range of D.C. electrical measurements, 50 microamps, to 20 amps, and 20 millivolts to 2,000 volts. Only 55/-.

MILLIAMMETERS—3 m.a. back of panel illuminated milliammeters. Skeleton type, 970 ohms D.C. with plain scale and 1in. needle with mica panel, back lamp and bracket. Great bargains at 3/9 post free. Bulgin Midgets, 8 m.a., 6/-; Sifam, 11in., 10 m.a., 8/6. 2,000 meters to select from. Switchboard, Portable and Lab. cheap.

FOCOMETER. Lens Calibrator for testing focal length of lens, with microscope stand, fine adjustment. Cost £30. 24/10/-.

HILGER REFRACTOMETER—Immersion Type for refractive index of liquids. Cost £25. New condition, £3/10/-.

H.F. AERIAL RADIATION METERS—Flat panel, 2 1/2 in. dial, Hot wire, 0-500 m.a., 7/8; 0 to 2 amps., 12/6; 0 to 2 amps., 12/6. 3in. dial ditto, 0-4 amps., 21/-; Panel 4in. dia., 3 amps., £1/10/-; 7in. dial, 2 to 15 amps., £1/15/-.

EVERSHED MEGGERS—Direct Reading-ohms to megs. Long scale dial, from £4/10/-.

BRIDGE MEGGERS for low and high res. tests. Cheap. **SILVERTOWN** Portable Tester. Combines Wheatstone Bridge, Galvo, shunts and ratios, as new. C.P.O. Plug-in Bridge Resistance Boxes, to 8,000 ohms. Large Stock.

ELLIOTT & E.E. No. 198, with moving-coil meter and graded Rheo. 37/6. Silvertown static horizontal Galvos, jewel pivots, 7/-.

AMMETERS—all ranges to 20 amps., 5/9.

Portable Sub-Standard Moving Coil Meters, mirror scale, C.Z. ammeters 5-0-5 a., reads to 1/10 amp., in screened case, 7in. x 7in. x 3 1/2 in., unused, 30/-.

MIRROR GALVOS, Reflecting Beam, by Paul Gambrell, Sullivan and Tinsley, £3. Standard Res. Boxes and Univer. Shunts, from 15/-.

Two Laboratory Table "Kelvin" Electrostatic Voltmeters, 100 to 600 volts, large scale, 70/-.

MICRO-AMMETERS for Valve Voltmeters, etc., 0 to 50 microamps full scale, 50 mV. moving coil, flush panel, 2 1/2 in. dial. Reads direct. Moving coil, 1,000 ohms, 40/-.

See "Wireless World," May 4.

CHARGE METERS—Weston Model 354. Central zero 1 to 15 amps., pol. mag. dead beat. Flush panel, 2 1/2 in. dial. Sale price, 5/-. Weston 0 to 30 m.a., mov. coil milliammeters, 17/6; 0-5 m.a., 17/6. Hoyt CZ mov. coil milliammeters, 25-0-25 m.a., 10/-.

VALVE BARGAINS for Transmitters. Marconi 35-watt 10-metre DFTI 27 Valves for 15/-.

Ediswan 30-watt VT18B £2 Valve for 7/6. T50 £3 Valves, 12/6. AT40, 10 watts, 4/-.

Mains Universal 7-pin Frequency Changer, 4/6. A.C. ditto, 4/6. Universal H.F. 7-pin Pentode, 4/6. H.T. Rectifiers, NU, for up to 5,000 volts, 4 valve, 250 watts, 35/-.

T2A 100-watt ditto, 40/-.

U3 1/2 wave, 20 watts, 2/6.

POCKET HEADPHONES, W.D., all leather headband, strap and cords, 2/6 pair. Wireless type, with aluminum headbands, 2/9. 4,000 ohms, 4/6.

House Office and Field Telephones, wall and table, 10/- and 15/- each.

IGNITION COILS. Remy Plain 4, 6 or 12 v. for spark, 3/6.

PARCELS of useful oddments for the Experimenter who wants a junk-box of Coils, Magnets, Wire, Chokes, Condensers, Switches, etc., mostly ex-W.D., parts worth a lot more than 10s. 6/-, or 7 lbs. for 4/-, post free. British Isles only.

DYNAMOS, ALTERNATORS, ROTARIES AND MOTORS ALL SIZES.
Send for Radio-Electrical-Scientific Illus. List "W." Free.

ELECTRADIX RADIOS
218, UPPER THAMES STREET, LONDON, E.C.4
Telephone: Central 4611

Q.C.C. Type S5 FREQUENCY CONTROL UNITS
As specified for the "W.W." 5-METRE PORTABLE TRANSMITTER.

Ground to within 5kc. of your specified frequency in the 7Mc. amateur band and supplied complete with official calibration certificate to an accuracy of 0.025%.

Send 11d. stamp for our full price list of all types of quartz crystals and radio transmission components.

THE QUARTZ CRYSTAL CO. LTD., Kingston Road, NEW MALDEN, Surrey. Phone: Malden 0334.

PRICES:
S5 UNIT (as illus.) £1
S6 CRYSTAL 15/- without holder
BASEBOARD MOUNT for the type S5 unit 1/3

ENGINEERS! ARE YOU EARNING LESS THAN £10 PER WEEK?

If so, you cannot afford to carry on without reading our 208-page Handbook. The book explains clearly and definitely many ways of carving out a successful career. Among other things it explains the Services of our unique Appointments Department; outlines Home-Study Courses in all branches of Civil, Mechanical, Electrical, Motor, Aero, Wireless, "Talkie" Engineering, Building, Govt. Employment, etc., and gives details of B.Sc., A.M.I.C.E., A.M.I.E.E., A.M.I. Mech. E., A.M.I.A.E., A.M.I.W.T., A.M.I.R.E., G.P.O., MATRIC., and all E. exams. We Guarantee "NO PASS—NO FEE." Whether you be an old hand or a budding apprentice get this book to-day. FREE and POST FREE.

268 PAGES **Free**

BRITISH INSTITUTE OF ENGINEERING TECHNOLOGY.
387, Shakespeare House, 17/19, Stratford Place, London, W.1.

COMPONENTS—SECOND-HAND, CLEARANCE, SURPLUS, ETC.

RADIO CLEARANCE, Ltd., continuing bargains in components, etc.

CENTRALAB Volume Controls Available as Follows. with switch, long spindle:—1,000, 5,000, 10,000, 25,000, 50,000, 100,000, 250,000, 2/- each.

G.E.C. Relays, make and break type, 3,300 ohms; 4/- each.

100 Watt Auto Transformers, 100-250 volts reversible, wire end type; 5/11 each.

STANDARD Telephone Mains Transformer. Type 1, input 200-250 volt, output 250v. 40 m.a., 4 volt 2.5 amp.; 2/6 each.

TYPE 2, input 200-250 volt, output 250 volt 200 m.a., 4 volt 2.5 amp.; 3/- each.

TYPE 3, input 200-250 volt, output 200 volt 500 m.a., 4 volt 4 amp.; 5/6 each.

HELLEN 8 mfd. Cardboard Electrolytics, 450 volt working, wire end; 1/- each.

CONDENSER Block, four, 0.05 mfd., metal cased, 500 volt working; 1/9 each.

CONDENSER Block, two, 6 mfd., 2.1 mfd., metal cased, 500v. wkg.; 2/5 each.

METAL Safety Case with Base and 2 Valve Holders, size 12 1/2 in. x 8 1/2 in. x 5 1/2 in.; 3/6 each; finished brown crackle.

METAL Safety Case with Base and 2 Valve Holders, size 12 1/2 in. x 8 1/2 in. x 5 1/2 in.; 3/6 each; finished brown crackle.

30 Mfd. 300 volt working, can type wet electrolytic; 1/6 each.

16 Mfd., 450 volt working; 1/- each.

ALL Orders to the Value of 5/- Post Free; postage A must be enclosed with orders for less than 5/-; enquiries 1/4d. stamp if reply expected. Hours of business: Week-days, 9 a.m. to 7 p.m.; Saturdays, 9 a.m. to 1 p.m. Postal rates apply to the United Kingdom only, orders for Ireland and abroad must include sufficient postage to cover whatever the value of same.

RADIO CLEARANCE, Ltd., 63, High Holborn, W.C.1. Telephone: Holborn 4631. [8561]

RYALLS RADIO, 280, High Holborn, London, W.C.1, offer new goods, post free.

ELLIPTICAL Speakers, Celstion, suitable Ekeo replacements, 750 and 1,250 ohms, less transformers, speech 25 ohms, new, handle 8 watts, carry up to 120 m.a.; 5/6 each.

NEW Ferranti Transformers, AF5, OPM16c (15/22/45-1), AF6c. OPM15c, OPM5 (4/7/10-1), AF15c, OPM6; all 6/9 each.

GARRAD AC Induction Type AC7a Gramophone Motors, with pick-ups complete, 200-250v., 12in. turntable and unit plate, auto stop, speed regulator, new; 32/6 each.

SPEAKERS, pairs, brand new, elliptical cone speakers, S made by first class firm, quality of reproduction outstanding, push-pull pentode transformer, fields 325 ohm for smoothing choke, 8,600 as bleeder, circuit available, handle 10-15w.; 14/- pair.—Ryalls Radio, see above. [8374]

E.M.I. Service Oscillator, in perfect condition, with calibration chart, 180-3,200 metres; £3/10.—P. Lyon, Churchgate St., Soham, Cambs. [8519]

SOUTHERN RADIO, 45, Lisle St., London, W.C. Ger-rard 6653.—Stocks of receivers and replacement components, as previously advertised. [8548]

COLLARO A.C./D.C. Record-changers, 200-250, plays eight 10in. or 12in. records, mixed, also incorporates repeater and retractor; limited quantity, £5/5, in sealed cartons.

HENRY'S, 72, Wellington Av., Stamford Hill, N.15. Stamford Hill 2907.

S.S.036 (17/6), S.S.S.F.R.C. (7/6), Colpak H.1.2.3 (27/6), Ferranti A.F.5 (7/6), Rothermel £4/4 Pick-up (30/-), all perfect.—Hewson, 28, Signhills Avenue, Cleethorpes. [8543]

3 WAVE-BAND Tuning Packs for British Valves, aligned and tested; 3-gang H.F., F.C., 32/6 only; 465 K/C 1FTs, for above, 2/6 each.—S.A. Radio, 293, Norwood Rd., S.E.24. [8539]

MAINS RADIO DEVELOPMENT COMPANY Offer immediate delivery, carriage paid; call mornings, telephone Tudor 4046; stamp for list 227; Transatlantic all-wave tuning packs now available from stock, stamp for details.

DUBILLIER Mica Tag Condensers, 0.00005, 0.0001, 0.0002, 0.0003, 0.0005 mfd.; 3d., 2/6 dozen.

AMazing Resistor Bargain, N.S.F. 1/2, 1 and 2 watt. A new, marked, colour coded resistors, 20 different useful sizes in parcel; 50 for 2/6 only.

CLIX Unused Chassis V-holders, 5-pin, 7-pin, 3d. each; all American sizes, 6d. each; best sleeving, 1 1/4 d. yd.; T.C.C. metal can 8 mfd., 600v. dry electrolytics, 2/3.

TUBULAR Condensers, 400 volt working, wire ends, best make, 0.0001-0.05 mfd., 4d.; 0.1 mfd., 4d.; 0.25, 0.5 mfd., 6d.

CENTRALAB Latest Potentiometers, long standard spindle, unused, all sizes, 5,000 ohms, 2 megohm, 2/-; with mains switch, 2/3.

POLAR Midget, Latest Three-gang Condensers, screened, trimmers, 1/4 in. spindle, 0.0005 mfd., 110 k/c tracker, unused; 2/6.

ERIE One Watt, colour coded, unused resistors, any size, 50 ohms to 5 megohms, your selection, 3d., 2/6 dozen; two watt, 6d.

MAINS RADIO DEVELOPMENT COMPANY, 4-6, Muswell Hill Rd., London, N.6. Tudor 4046. [8457]

ROGERS RADIO SPARES Offer the Following Goods by Return of Post: Rola G12 P.M., 55/-; Rola energisers, 47/6; Rola 8in., 13/6; T.C.C. metal 8 mfd. 600 volt, 2/6; 8+8 card, 2/6; 8 mfd. card, 1/6; resistances, condensers, motors, pick-ups, car radios; send stamp for list.—Rogers Radio Spares, 36, Newnham Terrace, Lambeth, S.E.1. [8559]

Wanted
WANTED, surplus electrical goods.—Description, quantity and price to Box 9866, c/o The Wireless World. [8497]

WE Buy for Cash All Types of Modern Second-hand Radio Sets and Accessories, test meters, parts, etc. We pay more than any other dealer. Part exchanges. Bring, send or will call.—University Radio, Ltd., 238, Euston Rd., London, N.W.1. Phone: Euston 3810. [8538]

REPAIRS AND SERVICE

"SERVICE With a Smile."

AMERICAN Valves, spares, linecords, rewinds; repairers of all types of American and British receivers.—F.R.I., Ltd., 22, Howland St., W.1. Museum 5675. [0434

LOUD-SPEAKER Repairs, British, American, any make, 24-hours service; moderate prices.—Sinclair Speakers, Alma Grove, Copenhagen St., N.1. [0590

GUARANTEED Repairs Any Transformers, choke, motor armature, converter, dynamo, etc.; keenest prices, immediate quotation, prompt, dependable service.—See below.

L.T.P. (LONDON TRANSFORMER PRODUCTS, Ltd.), Willesden, N.W.10. Willesden 6486 (3 lines). [6892

MAINS Transformer Service, Repairs, rewinds, or construction to specification of any type, competitive prices and prompt service.—Sturdy Electric Co., Dip-ton, Newcastle-on-Tyne. [0516

METROPOLITAN RADIO SERVICE.—Guaranteed repairs to American and British receivers; American valves, service parts and rewinds; trade supplied.—1021, Finchley Rd., N.W.1. Speedwell 3000. [0435

DEGALLER'S "Reliable Service With a Written Guarantee." First class workmanship, lowest prices; all British and American receivers; let American specialists do the job. 48-hour service.—Degaller's Ltd., 31, Craven Terrace, London, W.2. Pad. 6492. [8552

REPAIRS to Moving Coil Speakers a Speciality; cones and coils fitted, fields altered; prices, including eliminators, quoted; loud speakers, 4/-; L.F. and output transformers, 4/-, post free; guaranteed satisfaction; trade invited, estimates free; prompt service.—Loud-Speaker Repair Works, 5, Balham Grove, London. Battersea 1321. [0394

SITUATIONS VACANT

AIR MINISTRY.

DIRECTORATE of Scientific Research.

APPLICATIONS are invited for the Following Appointments for Service in the First Instance at Bawdsey Research Station, Woodbridge, Suffolk.

ASSISTANTS II, required to undertake the compilation and analysis of statistical data. A knowledge of the theory of probability is desirable but not essential. Candidates should have had mathematical training to the Inter B.Sc. standard. Salary scales:

MEN, £130-£12-£214; efficiency bar, £12-£310 a year.

WOMEN, £130-£12-£214; efficiency bar, £12-£260 a year.

SUCCESSFUL Candidates May be Given a Commencing Salary up to £214 a Year, according to qualification and experience.

THE Appointments are Non-pensionable, but entrants will be eligible for consideration for pensionable posts in the event of vacancies arising in the permanent establishment.

APPLICATIONS Should be Made on a Form to be Obtained, quoting the reference C.200, from the Superintendent, Bawdsey Research Station, Bawdsey Manor, Woodbridge, Suffolk, to whom it should be returned not later than the 16th June, 1939. [8529

AIR MINISTRY.

DIRECTORATE of Scientific Research.

LABORATORY Assistants Required at Air Ministry Station near Felixstowe; candidates should have a good general education, with theoretical training in electricity; practical experience of wireless receivers or of electrical testing is desirable.

SALARY 40/- (at age 19), rising to a normal maximum of 70/- a week.

APPLY by Letter, quoting reference No. C.207 to the Superintendent, Bawdsey Research Station, Bawdsey Manor, Woodbridge, Suffolk, stating age, training and experience; closing date for receipt of applications is 23rd June, 1939. [8549

CROWN Agents for the Colonies.

COLONIAL Government Appointments.

APPLICATIONS From Qualified Candidates are Invited for the Following Post:—

SUPERVISOR (Wireless) Required by the Government of Palestine for the Lydda and Haifa Airports for one tour of 18-24 months in the first instance. Salary £P.360-£P.10-£P.480 a year, plus expatriation allowance of £P.50 a year and a cost of living allowance at present fixed at £P.24 a year (£P.1 equals £1). Free passages and, if married, for wife and children, not exceeding four persons. Leave on full pay. Candidates, age 26-36, must hold the first class certificate of the Postmaster General as Wireless Telegraphists and have had experience in the supervision of the operating and maintenance of wireless receiving and direction finding stations and in the control of aircraft approaching, leaving and on the ground at airports. Preference to candidates who, in addition, are conversant with the operating of teleprinting circuits by the touch typing method.

APPLY at Once by Letter, stating age, whether married or single, and full particulars of qualifications and experience, and mentioning this paper, to the Crown Agents for the Colonies, 4, Millbank, London, S.W.1, quoting M/8530. [8547

LONDON.—P.A. manufacturers, long established, require experienced young assistant for testing, installation and service.—Box 28, c/o The Wireless World. [8557

MANAGER, small radio branch, must be experienced and energetic salesman, drive car and do service work; references essential.—Gerry, Bank St., Newquay. [8541

VACANCY for Apprentices in Radio Manufacturer's Organisation, constructing transmitters and receivers for Government Departments; works situated in Surrey.—Write Box 9867, c/o The Wireless World. [8501

RADIO.—Experienced draughtsman required (in the Midlands); used to small part mechanisms.—Write, giving particulars of experience, also state age and salary required, Box 9998, c/o The Wireless World. [8528

APPRENTICES Wanted for Industrial Electronics Laboratory, grounding of electrical fundamentals essential but no specialised knowledge necessary; small premium returnable as wages.—Write Furzehill Laboratories, Boreham Wood, Herts. [8530

P.A. Engineer Required, capable of designing and constructing all types of radio amplifiers, must be 23-30 and able to supervise small workshop; excellent prospects for keen man; Salary £4 per week.—Apply Box 2, c/o The Wireless World. [8531

QUALITY RADIO

OR

QUANTITY RADIO ?

If your ideal receiver consists of an instrument which will receive a colossal number of stations from all parts of the world at "pleasing" volume, with "radio reproduction," then obviously you will buy any good mass-produced receiver.

If, on the other hand, you are a music lover and your knowledge of Radio enables you to appreciate that there is nothing to equal a specially built Local Station Receiver with a Push-Pull Triode Output, together with a hand-made M.C. Speaker of unique design, then we submit the

S.S. SINGLE H.F. UNIT, 346 TYPE QUALITY AMPLIFIER & DUAL SUSPENSION AUDITORIUM SPEAKER

for your earnest consideration.

PRICED AT £20, we confidently believe that this equipment is the best possible musical value for money.

May we send YOU our latest catalogue and technical manual PRICE 6d.

Specified by the Experts



SALES

MARLBOROUGH RD., UPPER HOLLOWAY, LONDON, N.19. (Contractors to the G.P.O., etc.) LIMITED. Tel.: Archway 1661/2/3

Hours of Business— Monday to Friday, 8.30 a.m. to 6 p.m. SATURDAYS CLOSED

TO SERVICE MEN

Bargain Offer!!!

A SERVICE KIT FOR 17/6

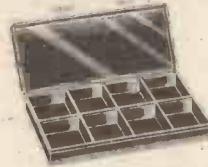

This Service Kit comprises:

- 4 VOLUME CONTROLS. 20,000, 50,000, 1 meg., 1/2 meg.
- 72 RESISTORS. Assorted, colour coded resistors, 1/2 to 3 watts.
- 2 DOZ. CONDENSERS. Assorted tubular, electrolytic and mica condensers.
- 1 STEEL CABINET. A very useful steel cabinet with partitions for above, screws, etc.

VALUE £4 for 17/6

KIT No. 2 comprising resistors and condensers only, as above 12/6

KIT No. 3 comprising volume controls and cabinet only 6/6

SPECIAL OFFER!!! Fully stocked Transformers by America's largest manufacturer, White they last.

All 230 v. primary and fully impregnated.	
T28708—375/375 v. 150 m.A., 6.3V5A, 2.5V5A, 5V3A	15/-
T19610—350/350 v. 100 m.A., 2.5V6A, 2.5V2A, 5V3A	12/6
T7236—375/375 v. 120 m.A., 6.3VCT, 4A, 5V3A	10/6
T7326—350/350 v. 100 m.A., 6.3VCT, 3A, 5V3A	8/6
T7397—350/350 v. 80 m.A., 6.3VCT, 3A, 5V3A	7/6
T7006—320/320 v. 80 m.A., 6.3V4A, 5V3A	7/6
T8625—320/320 v. 80 m.A., 2.5V6A, 5V3A	7/6
T464919—10V4A Primary Tapped 110—250 v.	5/6
T1113AB—110/230 v. 500 watt Auto Transformer	29/6
The following chokes are interwired and impregnated.	
T7007—250 m.A., 150 ohms, 20-8 Hy., cadmium shrouded	12/6
T7007A—150 m.A., 250 ohms, 30-12 Hy., cadmium shrouded	12/6
100 m.A., 20 Hy., 300 ohms, unshrouded	4/11
60 m.A., 15 Hy., 250 ohms	1/11

RADIOMART Telephone: MIDland 3254. 65N1 (Birmingham) Ltd. 44, HOLLOWAY HEAD, BIRMINGHAM

THE INSTITUTE OF WIRELESS TECHNOLOGY (Founded in 1925. Incorporated).

PROFESSIONAL MEMBERSHIP

The advantages of professional membership are open to all qualified wireless engineers.

Full information, with syllabus, may be obtained from the Secretary, Institute of Wireless Technology, 4, Vernon Place, Southampton Row, London, W.C.1. Phone: Holborn 4879.

SITUATIONS VACANT

AIR MINISTRY.

APPLICATIONS are invited for the Following Appointments for Service in the First Instance at Bawdsey Research Station, Woodbridge, Suffolk.

SCIENTIFIC Officers (Ref. No. C.201). Candidates should possess First or Second Class Honours Degrees in Physics, Electrical Engineering or Mathematics, and have had extensive practical experience in research and experimental work on radio and line communication.

SALARY Scale: £400 by £18 to £454 by £25 to £580 by £25 to £680 a year (men); £275 by £12 to £347 by £18 to £464 (women).

THERE is an Efficiency Bar at £580 a year (men) and £464 (women).

JUNIOR Scientific Officers (Ref. No. C.202). Candidates should possess a First or Second Class Honours Degree in Physics, Electrical Engineering or Mathematics, and experimental laboratory or works experience on radio and line communication. Post-graduate experience in radio research is desirable.

SALARY Scale: £275 by £18 to £347 a year (men); £275 by £12 to £320 a year (women).

SCIENTIFIC Officer Appointments will Carry Superannuation Rights under the Federated Superannuation System for Universities, the Government contribution being approximately 10% and the individual approximately 5% of salary. Junior Scientific Officer appointments will be brought under the scheme after two years' satisfactory service.

PROMOTION from Junior Scientific Officer to Scientific Officer and to the higher grades of Senior Scientific Officer (£680 by £25 to £800), and Principal Scientific Officer (£850 by £30 to £1,050), is governed by merit as and when vacancies arise.

TECHNICAL Officers (Ref. No. C.203). Candidates should have a technical training to the standard of an Honours Degree in Physics, Electrical Engineering or Mathematics, and have had extensive experience of experimental development work on radio and line communication.

SALARY Scale: £275 by £18 to £455 by £25 to £580 a year (men); £275 by £12 to £347 by £18 to £464 women. There is an efficiency bar at £455 (men) and £347 (women).

THE Commencing Salary, up to £455 (men) or £347 (women), will be determined according to the successful candidates' qualifications and experience.

PROMOTION to the Higher Grades of Senior Technical Officer (£680 by £25 to £800) and Principal Technical Officer (£850 by £30 to £1,050) is governed by merit as and when vacancies arise.

ASSISTANTS I and II (Ref. Nos. C.204 and C.205). Candidates should have had training to the standard of a University Degree in Physics or Electrical Engineering and experimental laboratory or works experience in communication engineering, preferably on the radio side.

ASSISTANTS III (Ref. No. C.206). Candidates should preferably have had training to the standard of a University Degree in Physics or Electrical Engineering and some experimental laboratory or works experience in communication engineering, preferably on the radio side.

SALARY Scales:— ASSISTANT I: £400 by £18 to £515 a year (men); £325 by £12 to £349 by £18 to £415 (women).

ASSISTANT II: £315 by £12 to £385 a year (men); £265 by £12 to £315 (women).

ASSISTANT III: £130 by £12 to £310 a year (efficiency bar at £214 a year) (men); £130 by £12 to £214 by £12 to £260 (efficiency bar at £214 a year) (women).

THE Commencing Salary for Assistants III may be up to £214 a year and in exceptional cases above according to qualifications and experience.

PROMOTION of Assistants from Grade to Grade is Governed by Merit as and when Vacancies Arise.

APPLICATIONS for Junior Scientific Officer and Assistant III Posts will also be considered from undergraduates who are taking their degrees this term but appointments will be subject to the satisfactory outcome of their Final examinations.

THE Technical Officer and Assistant Appointments are non-pensionable, but entrants will be eligible for consideration for pensionable posts in the event of vacancies arising on the permanent establishment.

APPLICATION Should be Made on a Form to be Obtained by Postcard quoting the appropriate reference from the Superintendent, Bawdsey Research Station, Bawdsey Manor, Woodbridge, Suffolk, to whom it should be returned not later than the 23rd June, 1939. [8550

RADIO Manufacturers in S.E. London Require the Services of Two Good Development Engineers, for the design of mass produced broadcast receivers.—Write in confidence full details of experience, salary required and age, to Box 25, c/o The Wireless World. [8544

TELEVISION Engineers and Production Men, with practical experience, required for development and production of Cathode Ray Tubes for domestic receivers.—Write in confidence full details of experience, age and salary required, to Box 26, c/o The Wireless World. [8545

RADIO Test Operators, male, with experience in routine alignment or fault diagnosis of broadcast receivers, required immediately.—Apply by letter only, stating age, previous experience and remuneration expected, to Employment Dept., E. K. Cole, Ltd., Southend-on-Sea. [8551

MALE Inspector Required for Checking Small Component Parts, e.g. stampings, turned parts, etc., to drawings; applicants should have had previous experience of a similar kind and have a fair knowledge of mathematics; age preferably 22-26 years.—Box 9975, c/o The Wireless World. [8524

INSPECTOR for Electrical Work Required by London County Council to Inspect Radio Receiving Sets, public address equipment, and 16 mm. cinematograph sound on film apparatus; must have experience of servicing such apparatus and a sound knowledge of electrical principles as applied to radio and cinema equipment; commencing pay, 93/- a week.

ENGAGEMENT for Indefinite Period, but, subject to satisfactory service, will, in the first instance, probably extend over a period of two years with prospect of further engagement; selected candidate subject to provisions of Local Government Superannuation Act, 1937.

APPLICATION Forms Obtainable by Sending Stamped Addressed Foolscap Envelope to the Chief Engineer (quote S 39/36), The County Hall, Westminster Bridge, S.E.1, returnable with copies of three recent testimonials by 17th June. Canvassing disqualified. [8525

SITUATIONS VACANT

AIR MINISTRY.

AERONAUTICAL Inspection Directorate.

VACANCIES Exist for Unestablished Appointments as Examiners in the W.T. and Instrument Branches. Qualifications:—

APPLICANTS for Vacancies in Instrument Branch must have Good General Education, theoretical knowledge of physics, and training in light engineering or instrument making. Candidates should be able to read drawings, understand specifications, and use micrometers and other types of measuring instruments. If necessary, preference will be given to candidates having a good knowledge of thermometry and optical and pressure measuring instruments.

APPLICANTS for Vacancies in W.T. Branch having the Following Qualifications will receive Preference: Good general education, sound technical knowledge of high-frequency engineering equal to City and Guilds Final Examination in Radio Communications, practical knowledge of modern W.T. and electrical equipment. Candidates should be able to read drawings, understand specifications, and use micrometers and other measuring instruments.

SUCCESSFUL Candidates will be given a Period of Training in Inspection, as applied to these subjects, not exceeding three months.

DURING Training, candidates will be regarded as on probation and paid at the rate of £184 a year; on satisfactory completion of the training course they will be appointed as Examiner and paid at £246 a year, rising by increments of £12 if service is satisfactory to £337, except that the starting salary for entrants below the age of 24 years will be reduced by £12 for each year below that age.

SUBSISTENCE Allowance, at the rate of £1/5 weekly, is payable whilst under training to married men (and others with certain dependents) who normally reside outside the training centre.

SALARIES are paid Monthly in Arrear.

CANDIDATES Must be Prepared to Serve in Any Part of the United Kingdom, and be willing to fly as observers in connection with their duties.

NORMAL Age Limits, 21-50 years; candidates between 50-55 years will be considered if they have had previous inspection experience.

CANDIDATES who, on interview, fail to qualify for the Examiner Grade may be considered for:—

ASSISTANT Examiner.—Salary scale, £184-£10-£246.

ASSISTANT Examiners do not undergo Training, but are appointed direct to an A.I.D. station; they may later become eligible for promotion to Examiner on attaining the requisite standard of efficiency, provided they are willing to undertake the obligations required of Examiners as above.

APPLICATION Must Be Made on Form 786, copies of which can be obtained on application (by post-card only), to:—

THE UNDER-SECRETARY OF STATE, Air Ministry (I.C.S./Rec.40), Berkeley Sq. House, Berkeley Sq., W.1. [8514]

MECHANIC or Technician Required for Radio Receiving Valve Works, preference given to one with experience in handling automatic grid winding machines and able to control the output of the Grid Department.—Write in confidence full details of experience, age and salary required, to Box 27, c/o The Wireless World. [8546]

PATENT AND TRADE MARK AGENTS

GEE and Co. (H. T. P. Gee, Mem. R.S.G.B., etc.) 51-52, Chancery Lane, London W.C.2. Holborn 4547-8. Handbook free. [0001]

ELECTRIC DRY SHAVERS

REMINGTON, Rand, Shavemaster, Packard, Casco and Rabaldo.—Trade enquiries to Leonard Heys, 36, Henry St., Blackpool. [0633]

WALNUT SET CABINETS



(BELMONT 900) (as illustrated) 21" long, 11" deep, 12" high. A really first-class piece of furniture.

4/6

Carr. Paid

4 Pole Single Throw Yaxley Rotary Switches 8d. ea. .0005 Mica Dielectric Reaction Condensers 8d. ea. Screw Fuse or Bulb Holders 4d. ea. Mains Transformers, 350-0-350, 200M.A. 4v. 2 1/2 amp. 4v. 5 amp. 13v. 2 amp. Input 200 to 250 volts. 5/6 ea. All post free. See previous adverts. for other genuine bargains.

UNIVERSAL, 8 & 10, Brown Street, MANCHESTER, 2. Phone: Deansgate 5009.

We do quite a lot of business making up transformers to customers own



specifications; but we have a standard list. May we send you a copy?

W. BRYAN SAVAGE LTD

Westmoreland Rd., London, N.W.9. Phone: Colindale 7131

THE BEST WAY TO LEARN MORSE

"MASTERS" INSTRUCTIONAL RECORDS Prepared by an ex-R.A.F. Signal Instructor, these records contain messages at a speed of from 2 to 20 words a minute. Details on request.

Price 2/6 each or Complete Set of Three 7/- C. E. MASTERS Orchard House, Finchampstead Road, Wokingham, Berks.

INDEX TO ADVERTISEMENTS

	PAGE
Armstrong Manufacturing Co.	4
Automatic Coil Winder Co., Ltd.	2
Belling & Lee, Ltd.	7
Birmingham Radiomart G5N1	6
British Institute of Engineering Technology	5
British Rola, Ltd.	5
British Thomson-Houston Co., Ltd.	5
Electradix Radios	6
Galpins Electrical Stores	2
Goodmans Industries, Ltd.	3
Grampian Reproducers, Ltd.	3
Henlys, W. T., Telegraph Works Co., Ltd.	7
Institute of Wireless Technology	7
London Radio Supply Co.	4
Masters, C. E.	8
McClure, John, Ltd.	8
Mullard Wireless	8
Pamphonic Reproducers, Ltd.	5
Premier Radio Co.	1
Quartz Crystal Co., Ltd., The	6
Salford Electrical Instruments, Ltd. .. Inside Front Cover	8
Savage, W. Bryan, Ltd.	8
Sound Sales, Ltd.	7
Taylor Electrical Co., Ltd.	3
Universal Electric	8
Voigt Patents, Ltd.	3
Vortexion, Ltd.	5
Webbs Radio	5

MISCELLANEOUS

CHEAP Printing.—1,000 billheads, 3/6; sample free.—Cretaway Press, 18, Buxted, Sussex. [8180]

G.P.O. Engineering Dept. (No experience required.) Commencing £3/13 per week. Age 18-25. Excellent prospects.—Free details of entrance examination from B.I.E.T. (Dept. 574), 17-19, Stratford Place, London, W.1. [8522]

EVERY Radio Dealer Who is Not a Regular Reader of "The Wireless and Electrical Trader" should send his trade card at once for a specimen copy and full details of the "Trader" Services. "The Wireless and Electrical Trader" has the widest influence, the largest weekly circulation, and is read by all the leading manufacturers and traders. Trade only, 15/- per annum, post free.—Published at Dorset House, Stamford St., London, S.E.1. [0615]

"ENGINEER'S Guide to Success" Shows How to Qualify in Television Radio Engineering and Servicing, sound, recording, wireless communication, etc., by studying at home with the T.I.G.B. write to-day for this Great Guide—free—which gives full particulars, contains the world's widest choice of engineering courses—over 200—and also gives the regulations for qualifications such as A.M.I.E.E., A.M.I.R.E., A.M.I.T.E., A.M.I.W.T., C. and G., etc. Training until successful guaranteed.—The Technological Institute of Great Britain, 82, Temple Bar House, London, E.C.4. (Founded 1917. 20,000 successes.) [8526]

PATENTS

THE Proprietor of British Patents Nos. 426,227 and 426,228, relating to "Improvements in or relating to radio Signalling," is desirous of entering into negotiations with one or more firms in Great Britain for the purpose of exploiting the invention either by sale of the Patent Rights or by the grant of Licences on reasonable terms.—Interested parties who desire further particulars should apply to Albert L. Mond and Thiemann, of 19, Southampton Buildings, Chancery Lane, London, W.C.2. [8523]

TUITION

RADIO Training—P.M.G. exams. and I.E.E. Diploma; prospectus free.—Technical College, Hull. [0611]

PRACTICAL Radio and Television Home Study Courses; booklet free.—I.P.E., 3, Shirley Rd., London, W.4. [8506]

WIRELESS.—Complete training, Marine, Broadcast and Television. Posts waiting. Mod. fees. Boarders taken. Approved college, prosp.—Dept. W., London Radio College, Grove Park Rd., London, W.4. (Chi. 3244.) [0580]

BUSINESSES AND PROPERTY FOR SALE, TO BE LET, OR WANTED

NEED for Radio and Cycle Dealer on Large New Estate. Main road position. Success assured. No premium.—Apply Fairway Homes, Mutton Lane, Potters Bar, Tel.: 931. [8477]

RADIO and Electrical Business, well established, modern shop, living accommodation; Murphy, Bush, H.M.V., Pye and Mullard agencies; television area; genuine; owner going abroad.—Apply Box 22, c/o The Wireless World. [8535]

"THE Wireless and Electrical Trader" is an essential part of the equipment of every Wireless Trader; its pages reflect the very latest turn of trade events, and it is read by all the leading dealers and manufacturers, for particulars of businesses offered or wanted. By subscription to the trade only, 15/- per annum, post free.—Send your trade card for specimen copy to Dorset House, Stamford St., London, S.E.1. [0614]

BOOKS, INSTRUCTION, ETC.

UNEQUALLED Record of Progress. "Wireless World" (unbound), 1928-38.—Offers to Granville Stephens, "Evening News" (Subs), Nottingham. [8520]

ALL Wireless and Radio Engineering Books Available on New Financial Terms, as low as 2/6 monthly.—Write a card for details from Phoenix, Chandos Place, W.C.2. [8484]

AMERICAN Valve Data.—The new 200-page Raytheon Valve Data Book gives full characteristics and applications of all types of American valves; invaluable to all servicemen; post free, 2/3; abroad, 3/—Leonard Heys, 36, Henry St., Blackpool. [0594]



3-Band Tuning Unit

TYPES ACT5 & UT5

5-waveband Tuning Units of quality, covering the following ranges: 12-35 m.; 30-80 m.; 75-200 m.; 200-550 m.; 660-2,000 m. Tuned RF stage on all bands; triode hexode frequency changer. Full vision scale with spreader drive. Hand built and calibrated. For use with I.F.s of 465 Kcs. Complete with 4 v. AC valves or 6.3 v., 2 amp. E type valves.

PRICE £5. 10. 0

3 BANDS from 16 to 2,000 m. £4.10.0
4 BANDS from 12 to 2,000 m. £5. 0.0
6 BANDS without gaps from 4 1/2 to 2,000 m. £8. 0.0

Full details on request.

JOHN McCLEURE LTD. (G6JM) ERSKINE ROAD, LONDON, N.W.3. PRImrose 5435

The ELEMENTARY PRINCIPLES of WIRELESS TELEGRAPHY and TELEPHONY

Third Edition (1930) Revised by O. F. Brown, B.Sc.

PRICE 7/6 by post 8/-

by R. D. BANGAY

The standard book of instruction for wireless students. Deals thoroughly with modern developments. Leaflet with full particulars and synopsis of chapters sent on request.

From all leading Booksellers or direct from the Publishers

LIFFE & SONS LTD., Dorset House, Stamford St., London, S.E.1 w.w.97

RADIO LABORATORY HANDBOOK

By M. G. SCROGGIE, B.Sc., A.M.I.E.E.

issued in conjunction with "The Wireless World"

384 pp.

211 illustrations

PRICE 8/6 NET

By post 9/-

"Radio Laboratory Handbook" is the only practical and reliable handbook on the subject. It gives the serious wireless worker complete information from first-hand experience about laboratory equipment, the instruments which are necessary and the correct methods of operating them.

The fundamental principles are fully discussed, as well as the sources of power and signals, instruments and measurements. Other sections deal with ultra-high-frequency work, the working out of results, and reference data. There is also a collection of the most useful symbols, abbreviations, formulae, laws, curves, tables and other data.

A complete index, numbered sections and cross references enable the reader to find what is required without loss of time.

From Bookstalls and Booksellers or direct from the Publishers

ILIFFE & SONS LTD., DORSET HOUSE, STAMFORD STREET, LONDON, S.E.1

The ELECTRICAL REVIEW

The Complete Technical Journal

Practical articles on all aspects of electricity supply and utilisation—industrial, commercial and domestic. Latest news of the electrical industry and developments. Advertisement pages form a comprehensive buyers' guide.

Contents of Special Issue, June 9th :—

THE HARROGATE CONVENTION

Report and pictures of the annual meeting of the Incorporated Municipal Electrical Association.

THE GRID IN 1939

A former general manager of the Central Electricity Board sums up achievements to date.

CONTRACTORS AND SUPPLY AUTHORITIES

Methods of co-operation adopted at Maidstone are set out by the borough electrical engineer.

APPLIANCE PROBLEMS

The sales manager of a well-known manufacturing company gives his views on the requirements of the public and the way to meet them.

EVERY FRIDAY 6d. Subscriptions: United Kingdom £1 14 8
Canada £1 12 6. Other Countries
£2 1 6 per annum, post free.

ELECTRICAL REVIEW LTD.

Dorset House, Stamford Street, London, S.E.1

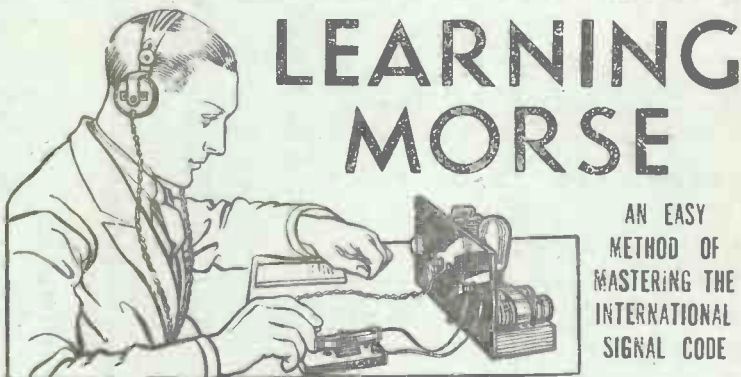

AN EASY
METHOD OF
MASTERING THE
INTERNATIONAL
SIGNAL CODE

Published from
the Offices of

The **Wireless World** 6^D NET

ILIFFE & SONS LTD., Dorset House, Stamford St., London, S.E.1

BY POST 7d.
W.W.93

SECOND EDITION

—Completely Revised

RADIO DATA CHARTS A SERIES OF ABACS

Providing most of the essential Data required in
receiver design

By R. T. BEATTY, M.A., B.E., D.Sc.

PRICE 4/6 net

BY POST 4/10

From all leading booksellers, or direct from the Publishers,
Published from the offices of "THE WIRELESS WORLD,"
DORSET HOUSE, STAMFORD STREET, LONDON, S.E.1

W.W.93

Mention of "The Wireless World," when writing to advertisers, will ensure prompt attention.

What Does

**BEVERLEY
BAXTER**

say about it?

The news is often confusing. One thing seems to contradict another, and events move too fast for a plain man to make up his mind.

That is why thousands of people turn to Beverley Baxter's article in the **SUNDAY GRAPHIC**. They know that his views are sound, clear and logical. They can rely upon Beverley Baxter, M.P.

Every Sunday in the

**SUNDAY
GRAPHIC**

The Paper for "Inside Information"

The **Wireless** ^{6^D}
World
THE PRACTICAL RADIO & TELEVISION JOURNAL

Thursday, June 15th, 1939

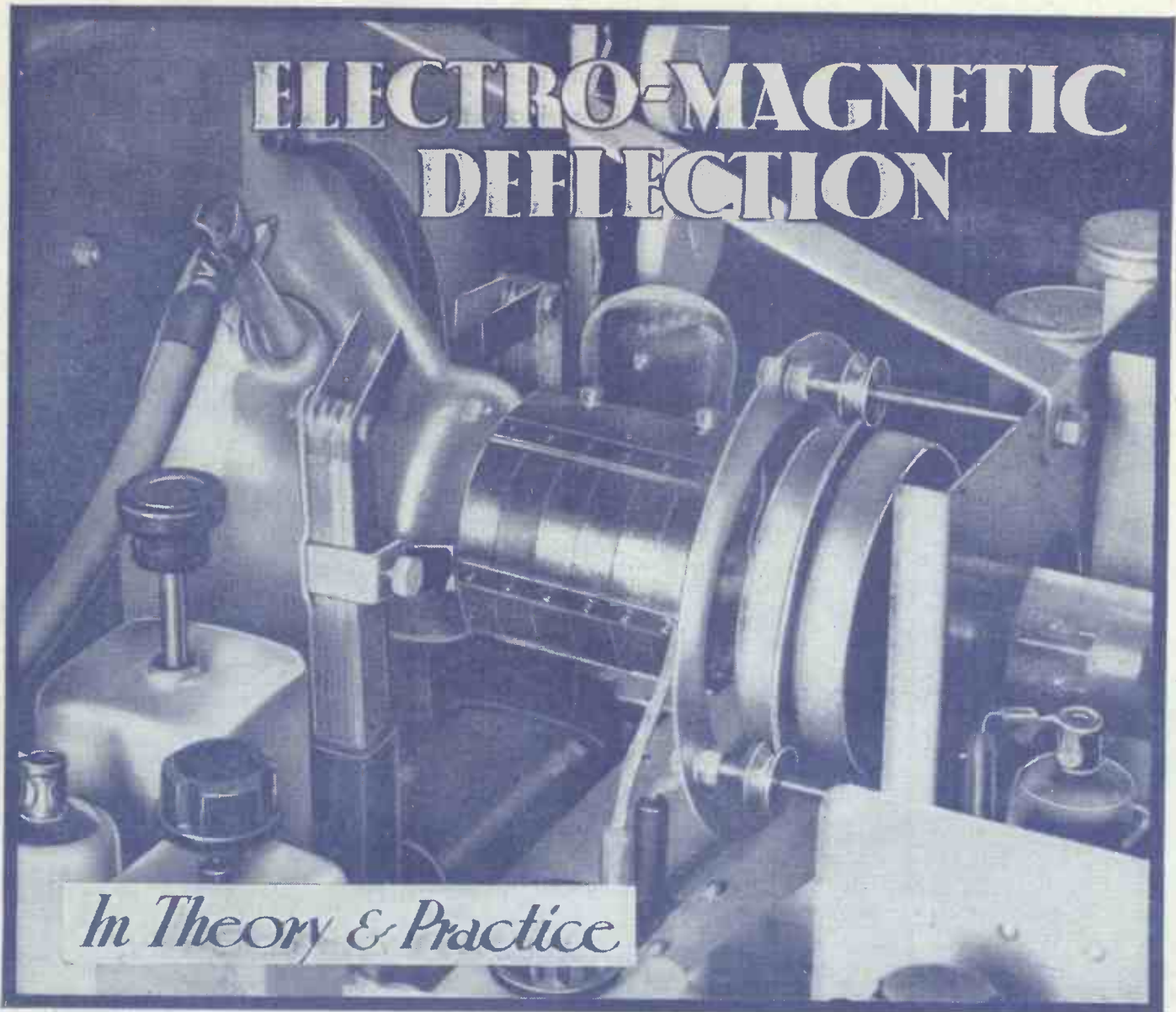

"THE WIRELESS WORLD" ENDORSE OUR BELIEF!

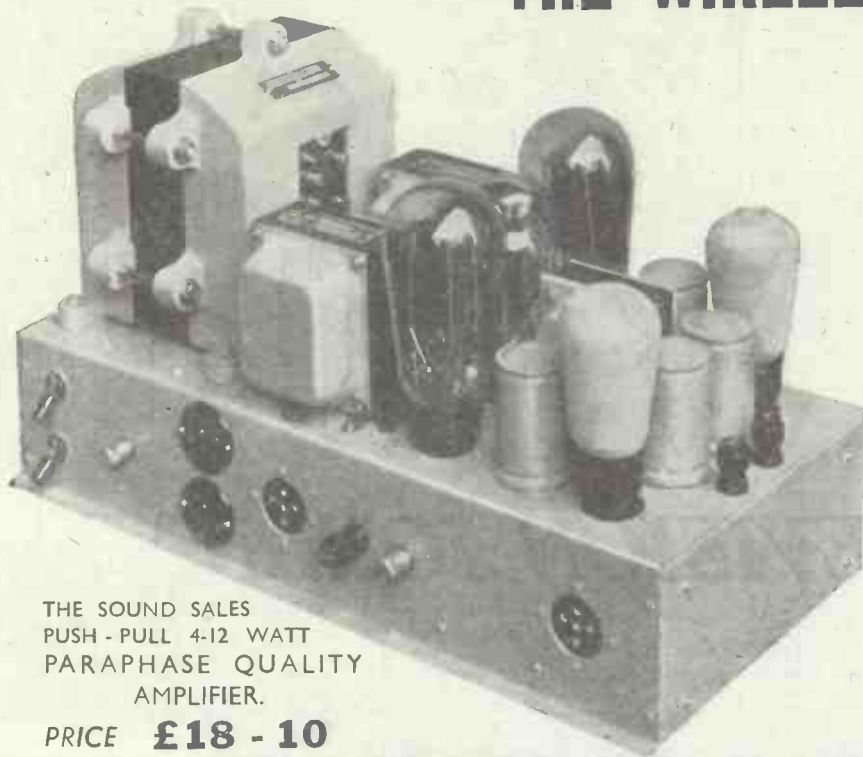

THE SOUND SALES
PUSH - PULL 4-12 WATT
PARAPHASE QUALITY
AMPLIFIER.
PRICE £18 - 10

We firmly believe that there is nothing to surpass the reproduction obtainable with a Paraphase Coupled Amplifier, and we maintain that SOUND SALES 12 WATT PUSH - PULL PARAPHASE QUALITY AMPLIFIER is a *supreme example* of this type.

Our opinion was endorsed by "The Wireless World" in their issue of January 13th, 1938, and it is the considered opinion of many satisfied SOUND SALES customers that the performance of this Amplifier is still unequalled—NOTHING BUT SOUND SALES EXCLUSIVE "TRI-CHANNEL" AMPLIFIER COULD BE BETTER.

May we send YOU our latest catalogue and technical manual? PRICE 6d.

SOUND SALES LTD., MARLBOROUGH ROAD, UPPER HOLLOWAY, LONDON, N.19. Telephone: ARChway 1661-2-3
Contractors to the G.P.O., Air Ministry, War Office, Office of Works, etc.

'AVO' Precision

ELECTRICAL TESTING INSTRUMENTS

The ALL - WAVE AVO - OSCILLATOR

An accurate modulated oscillator covering from 95 Kc. to 40 Mc. by six fundamental ranges. Extended to 80 Mc. by harmonic calibration. Accuracy within 1%. Externally modulated, internally modulated, or R.F. Signal obtained at will. Double attenuation enables signals to be varied from a few microvolts to 50 Millivolts, with a force output of 1 volt. A barretter in the battery model increases L.T. Battery life.

BATTERY MODEL 9 Gns. (including batteries)
A.C. MAINS MODEL 10 Gns. (Leather carrying case 35/-)

BRITISH MADE

The Model 7 - 46 RANGE UNIVERSAL AVOMETER
Electrical Measuring Instrument

A compact multi-range A.C./D.C. meter, with 46 ranges covering A.C. and D.C. amperes and volts, also resistance, capacity, audio-frequency power output, and decibels. No external shunts or series resistances required. Conforms with B.S. first grade accuracy requirements; 5in. mirror scale. Provided with automatic compensation for errors arising from temperature variations. Protected by an automatic cut-out against damage through overload 16 Gns.

Sole Proprietors and Manufacturers:
THE AUTOMATIC COIL WINDER & ELECTRICAL EQUIPMENT CO., LTD.,
Winder House, Douglas Street, London, S.W.1. Phone: Victoria 3404-7.

The UNIVERSAL AVOMINOR
Electrical Measuring Instrument

22 Ranges of DIRECT READINGS

A compact precision moving-coil instrument for all A.C. and D.C. testing. It has 22 ranges for measuring A.C. voltage, D.C. voltage, current and resistance. All readings are direct. No calculations. The high total resistance of the instrument—200,000 ohms—ensures accurate readings. Complete with leads, interchangeable crocodile clips and testing prods; and instruction booklet £5.10 (Leather carrying case 10/-)

OTHER 'AVO' INSTRUMENTS include

36 Range Universal AvoMeter	13 gns.
22 Range D.C. AvoMeter	9 gns.
'Avo' Valve Tester (with Universal Panel)	12 gns.
'Avo' Universal Valve Panel alone	3 gns.

● Write for fully descriptive leaflets.

"RADIO SERVICING SIMPLIFIED"
A popular text book written to conform with modern requirements and in the light of present day knowledge. Embraces the whole routine of testing modern receivers. Fully illustrated.
Price 2/6 (post free 2/10)

Mention of "The Wireless World," when writing to advertisers, will ensure prompt attention.

The Wireless World

THE PRACTICAL RADIO JOURNAL
29th Year of Publication

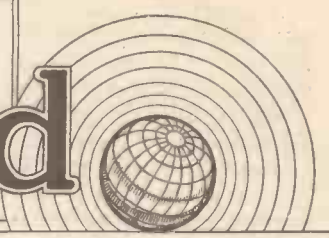
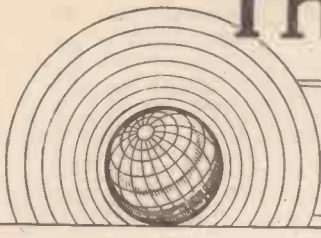

No. 1033.

THURSDAY, JUNE 15TH, 1939.

VOL. XLIV. No. 24.

Proprietors : ILIFFE & SONS LTD.

Editor :
HUGH S. POCOCK.

Editorial,
Advertising and Publishing Offices :
DORSET HOUSE, STAMFORD STREET,
LONDON, S.E.1.

Telephone : Waterloo 3333 (50 lines).
Telegrams : "Ethaworld, Sedist, London."

COVENTRY : 8-10, Corporation Street.
Telegrams : "Autocar, Coventry." Telephone : 5210 Coventry.

BIRMINGHAM :

Guildhall Buildings, Navigation Street, 2.
Telegrams : "Autopress, Birmingham." Telephone : 2971 Midland (5 lines).

MANCHESTER : 260, Deansgate, 3.
Telegrams : "Iliffe, Manchester." Telephone : Blackfriars 4412 (4 lines).

GLASGOW : 26B, Renfield Street, C.2.
Telegrams : "Iliffe, Glasgow." Telephone : Central 4857.

PUBLISHED WEEKLY. ENTERED AS SECOND CLASS MATTER AT NEW YORK, N.Y.

Subscription Rates :

Home and Canada, £1 10s. 4d. ; other countries, £1 12s. 6d. per annum.

As many of the circuits and apparatus described in these pages are covered by patents, readers are advised, before making use of them, to satisfy themselves that they would not be infringing patents.

CONTENTS

	Page
Editorial Comment	549
Line Deflectors	550
Regimented Listening	553
Problem Corner	553
Vertical or Inverted "L" Aerials	554
Radial Scanning	555
Inexpensive Reording Amplifier	556
Start Point	558
Unbiased	560
News of the Week	561
Noise in Television Receivers	563
Philco P429 : Test Report	564
Five-metre DX	565
Professional Status for the Radio Engineer	566
Random Radiations	567
Letters to the Editor	568
Television Programmes	569
Recent Inventions	570

EDITORIAL COMMENT

Wireless Out-of-doors Summer Activities

THE recent spell of fine weather, which might have been expected to have resulted in some measure of slackening of interest in the primarily indoor hobby of wireless experimenting, seems to have produced the converse effect at least so far as the devotees of 5-metre communication are concerned.

As notes in this and the previous issue have shown, the conditions for long-distance propagation on this wavelength have been unusually good, and many transmitting amateurs have availed themselves of the ideal weather conditions to take portable equipment to high ground in order to make the most of the opportunity of putting some really long-distance communications on record.

We hope that careful records have been made of all these observations, and that when analysed and compared with meteorological reports of the period they may shed new light on the apparent anomalies of transmission with these short wavelengths.

The New Portables

The normal seasonal increase of interest in portables has also risen more steeply during the past few weeks, not only as a result of the fine weather but under the stimulus of the new portables working entirely from dry batteries, an example of which is reviewed in this issue. With an LT capacity in working hours comparable with that of the HT battery it is now well worth taking a portable on holidays which normally would take one outside the range of battery-charging stations.

In conclusion, may we presume to offer a suggestion to those who, as part

of their resolution to make their holiday as complete a change as possible, are grimly determined not to go near a wireless receiver until they return once again to the common round.

Not the least interesting prospect of a stay in another part of the country is the chance which it offers of comparing receiving conditions with those to which one has become accustomed at home. The change of scene in the ether may be quite as stimulating as the outlook from the hotel window, and in the West of England during the next few weeks the visitor will have difficulty in keeping himself aloof from discussions of the new transmitters at Start Point and Clevedon.

Television and the Cinema

FOR most people the statement that television will eventually become as integral a part of cinema entertainment, as it is now becoming in the home, is axiomatic.

The question that is exercising their minds is just how soon the first trial efforts will resolve themselves into a regular service.

New developments in the past have suffered from an excess of zeal on the part of those responsible for advance publicity. The public have grown accustomed to the shape of the shadow too long before the actual event to show enthusiasm when it is upon them.

In future they may be well content to judge progress for themselves by events, and not necessarily those which are most loudly heralded. The news recorded on another page that a school has been established for the training of cinema operators in television technique is a small item, but one of more than usual significance.

Line Deflectors By D. V. RIDGEWAY (Baird Television, Ltd.)

AS recently as two years ago the question "Electrostatic or Magnetic Deflection?" was distinctly controversial. Now the scales seem to have definitely tilted in favour of magnetic deflection in commercial television receivers. Last year at Olympia about 80 per cent. of the receivers used magnetic deflection, of which the general principles of design are discussed in this article, and there is every reason to believe that this percentage will have increased at the next exhibition.

IT is becoming obvious that all-magnetic scanning is very much more efficient and more commercially economic than electrostatic deflection. One firm of manufacturers, on their last year's model, only required 1.4 W from the HT supply to obtain the necessary frame scan on a 12in. CR tube.

Due to the rapidly increasing importance of magnetic scanning and the small amount published on the subject, it is felt that an article discussing some of the more general principles of magnetic line-deflector design would be of interest.

The line-deflector unit usually consists of a pair of specially shaped coils, fastened round the neck of the CR tube, the coils being surrounded by a suitable iron circuit. In one type of deflector unit there is a second pair of coils on top of the first pair, but at right angles to them. This second pair is used for frame scanning.

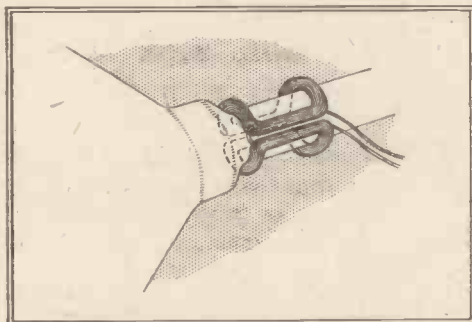

Fig. 1.—Line deflector coils mounted in position, but with iron shield removed.

In order to simplify things, let us examine the type of line deflection system that uses one pair of coils (in their iron circuit) for line scanning and a separate yoke for frame scanning. The coils themselves are seen to be rather an unusual shape (see Fig. 1). What exactly governs their physical dimensions?

An important point to remember in designing magnetic deflection systems is the need for obtaining a uniform deflecting field over the area in which the beam actually moves. Considerable distortions in the field can be tolerated provided they are outside this area.

Let us observe the results of a series of

GENERAL PRINCIPLES OF THE MAGNETIC TYPE

experiments to determine the correct coil shape for obtaining a sufficiently uniform field.

It will become obvious later in the article that one of the factors determining the coil shape is the CR tube neck diameter. Therefore for the following experiments let us assume that a tube with a 1 3/8 in. diameter neck is to be used.

A pair of coils of a few hundred turns of, say, No. 28 SWG enamelled wire are hank-wound on to narrow bobbins approximately 1/4 in. wide and 2 in. square. The cheeks and centre of the bobbin are removed and the windings are taped up with a layer of oiled silk.

Let us place our two experimental windings side by side at a distance of 1 3/8 in. apart and connect them to a battery in such a way that the fields are aiding each other. Iron filings are used to study the

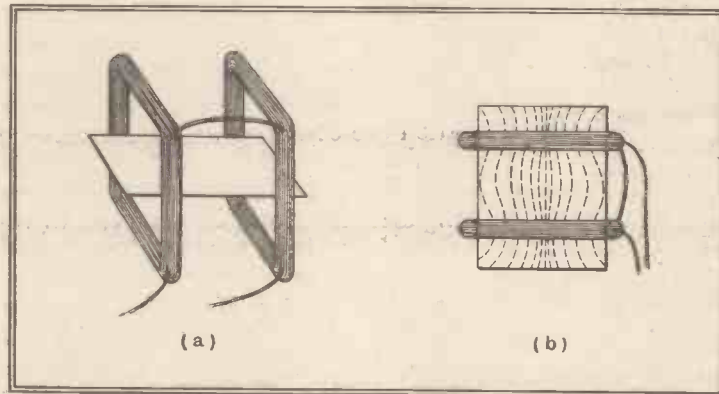

Fig. 2.—Exploring the magnetic field: diagram (a) shows the card in position and (b) indicates the field shape with coils as in (a).

shape of the field. A piece of card is cut out and placed inside the coils, as shown in Fig. 2 (a). With the battery connected, iron filings are sprinkled on to the card, where they will show the shape of the field in the plane of the card.

With an arrangement as in Fig. 2 (a) the field shape will be found to be very much like that shown in Fig. 2 (b). It will be seen that the field is uniform in the centre of the coils, but that it very rapidly gets weaker and spreads out as it nears the sides of the coils.

As the beam will be moving over a much larger area than the uniform area of this field, it is necessary to improve on this and make the field uniform over a larger area.

The two coils are bent round a piece of 1 3/8 in. diameter tubing, so that they are touching each other along the sides, as in Fig. 3 (a).

The field is examined again and found to be similar to that shown in Fig. 3 (b). It will be seen that under these conditions the field bends in at the sides instead of outwards as before, showing that the field is now stronger at the sides than at the centre.

If the coils are bent slightly apart at the sides, the lines of force at the sides of

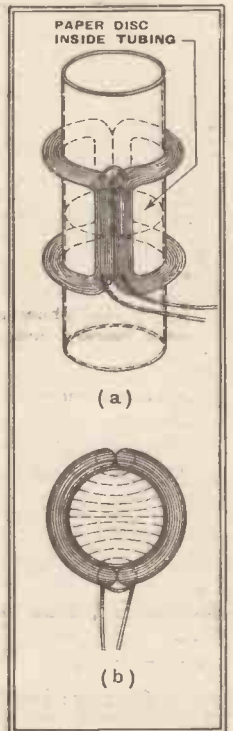

Fig. 3.—Examining the field due to coils shaped as shown.

the field may be straightened up to give quite a reasonably

uniform field between the coils, and this gives a similar field to a pair of coils close on the tube neck that are not quite so wide (that is, the sides do not go so far round the neck as to touch each other). A pair of coils bent, as in Fig. 1, will give a field similar to that shown in Fig. 4.

There is, therefore, a definite optimum width of coil to give the most uniform field through a given

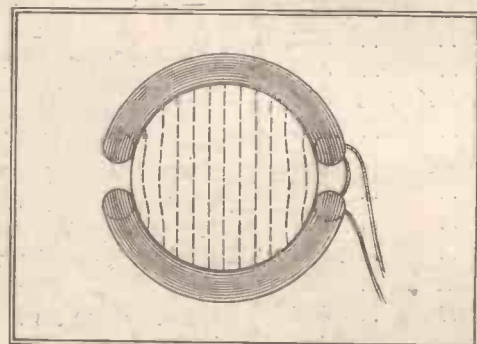

Fig. 4.—The field shape of coils shown in Fig. 1.

cathode-ray tube neck diameter.

There are two main troubles experienced when the beam moves in a non-uniform field:—(1) Defocusing. (2) Scan distortions.

Line Deflectors—

As is well known, the electrons are deflected at right angles to the lines of force in the deflecting field. In the case of a uniform scanning field, the electrons in the

of the shape shown in Fig. 3 (b), the electrons in the beam will be deflected, as shown in Fig. 5 (c). This line focus will be finer at the ends than in the centre, but only because the spot has become shaped

able, in order to obtain a satisfactory uniform field, to keep the coils a given distance apart along their length. If the coils are mounted directly on to the neck of the tube, and as it is advantageous to make

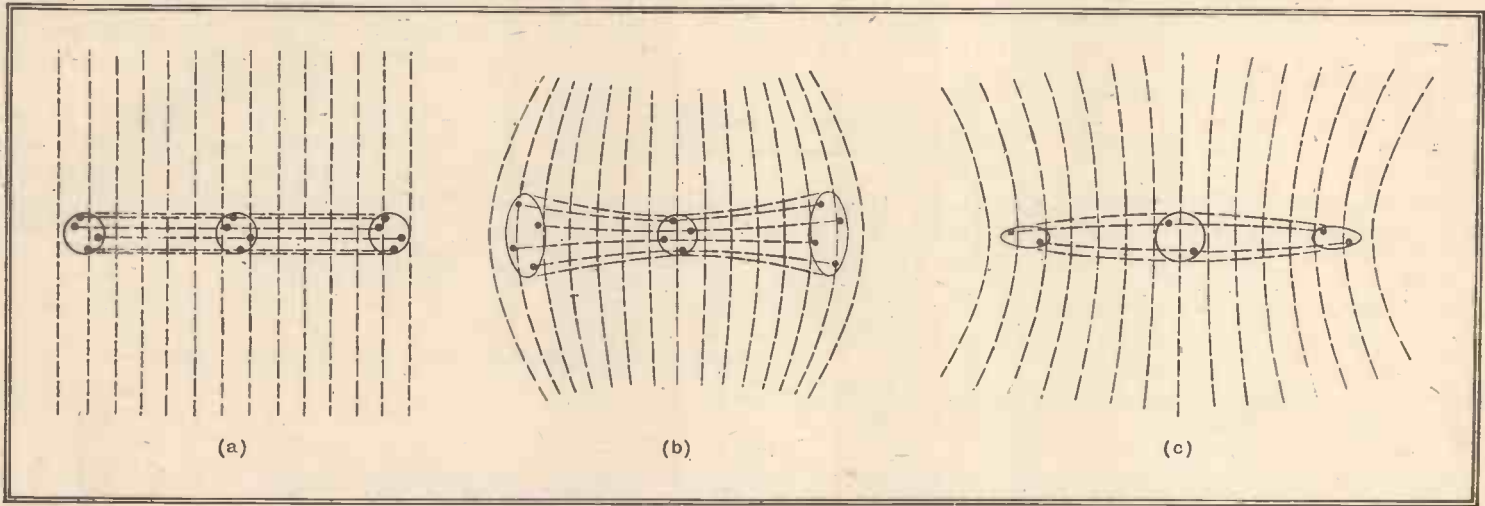

Fig. 5 (a).—Showing how electrons in the beam move parallel to one another when in a uniform deflecting field and produce a line of uniform width with rounded ends. (b).—Effect of a non-uniform deflecting field on the electron beam. (c).—Another effect of a non-uniform field on the electron beam.

beam will move as shown in Fig. 5 (a) (obviously this sketch is very exaggerated to illustrate the point).

All the electrons move parallel to each other, and a line of uniform width with a round spot at both ends is formed. Now, should the field be non-uniform, as in the case of Fig. 2 (b), with the lines of force spreading outwards, the electrons in the beam will tend to move as shown in Fig. 5 (b).

The line will then fan out at the ends and the spot at the ends of the line will be elliptical. This will give very bad line focus, the sides of the scan being badly defocused. Should the non-uniform field be

like a spear head towards the ends of the lines. This will also give bad focus trouble on the sides of the scan.

In Figs. 6 (a) and (b) it is shown how non-uniform fields can distort the top and bottom of the scan. Naturally the entire beam moves at right angles to the lines of force of the scanning field, just as each electron does. Thus lines at the top and bottom of the scan will be distorted.

Several factors decide the length of the line-scanning coils:—

- (1) Tube shape.
- (2) "Shadowing" troubles.
- (3) Focus coil position.

With regard to tube shape, it is prefer-

able, in order to obtain a satisfactory uniform field, to keep the coils a given distance apart along their length. If the coils are mounted directly on to the neck of the tube, and as it is advantageous to make

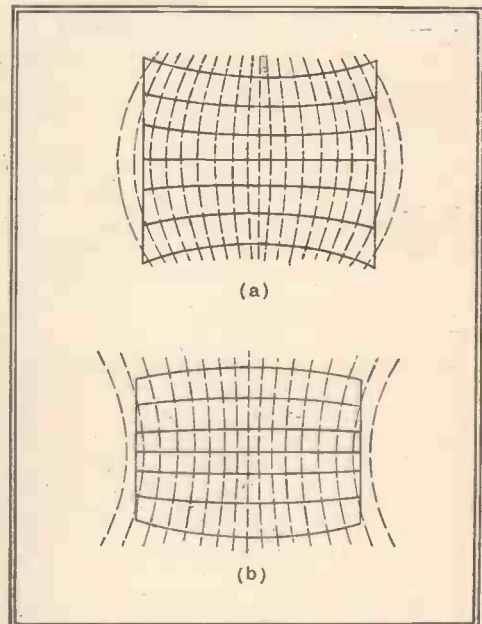
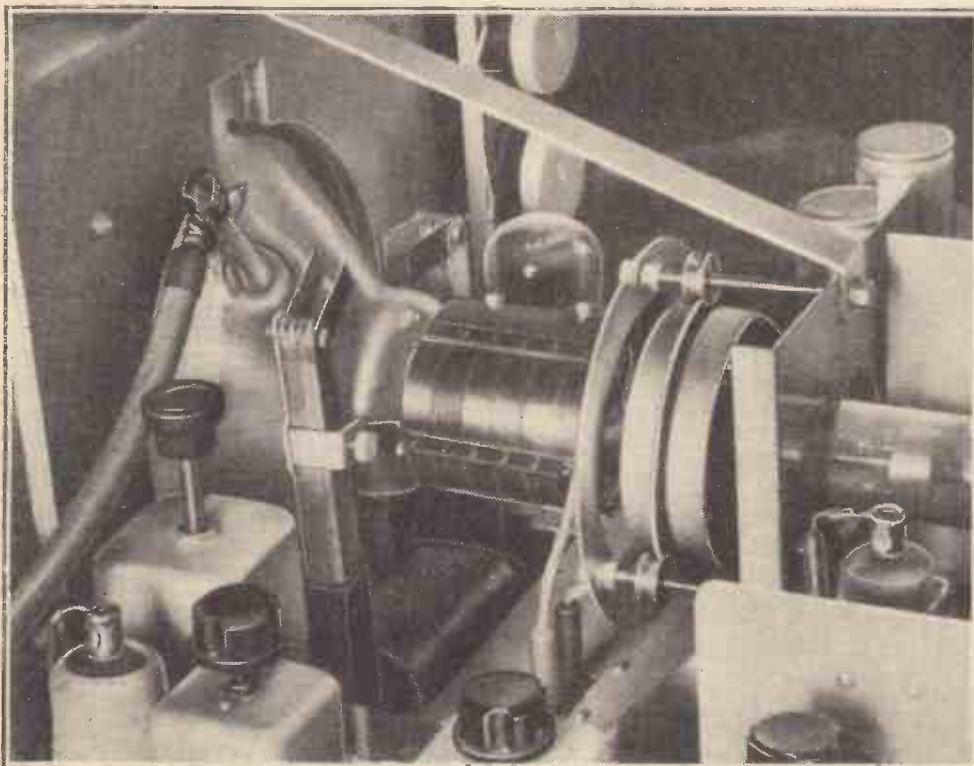

Fig. 6.—Showing how the non-uniform fields represented in Figs. 5 (b) and (c) can distort the lines towards the top and bottom of the raster.



A close-up of a television receiver using the kind of deflecting coils discussed in this article.

the neck joins the bulb (if the coils are not to ride up the bulb).

"Shadowing" is said to take place when the deflected beam hits the glass wall of the tube (usually where the neck joins the bulb), cutting off the scan before the required amplitude on the screen can be obtained.

In the case of a magnetic deflector unit, the beam moves through the field describing a circle, but for practical purposes it is near enough correct to assume that the beam moves in a straight line from the centre of the deflecting field to the screen. From Fig. 7 it will be appreciated that for a given amplitude scan on the screen, if

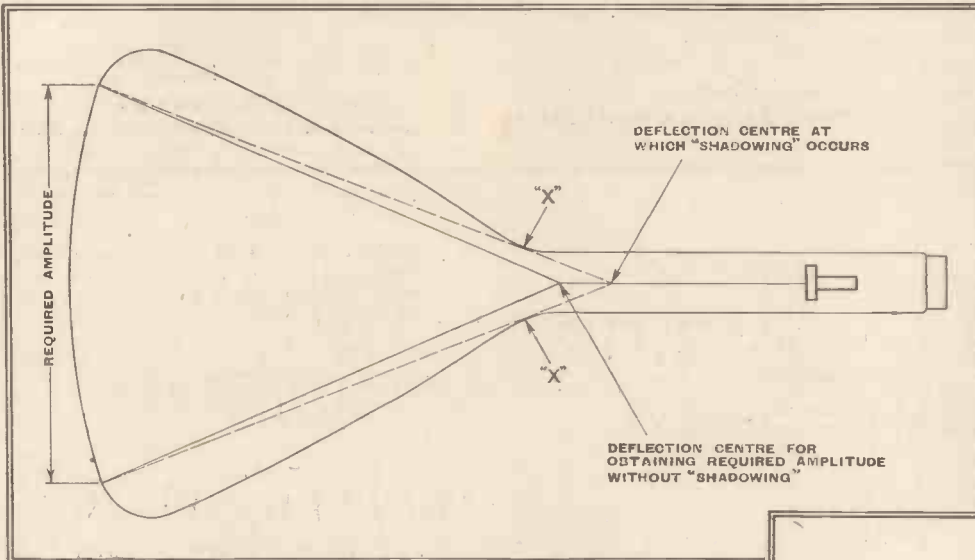

Fig. 7.—How shadowing may be caused when the deflection centre is too far back from the screen.

the deflection centre is too far back the beam will hit the inside of the neck at a point X. If the current through the coils is increased, the scanned area on the screen will not increase, as bad "shadowing" is taking place.

If more amplitude is required on the screen the only method of obtaining it clear of "shadowing" is to reduce the length of the deflector unit and so move the deflection centre nearer to the screen. (It will be appreciated that more power will then be required to obtain the same amplitude as the length of the beam throw has been reduced, and it is therefore necessary to scan over a wider angle. Also the reduction of the length of the deflecting field will result in lower efficiency, as the beam is not under the influence of the deflecting field for so long.) So it will be seen that to work at the greatest effi-

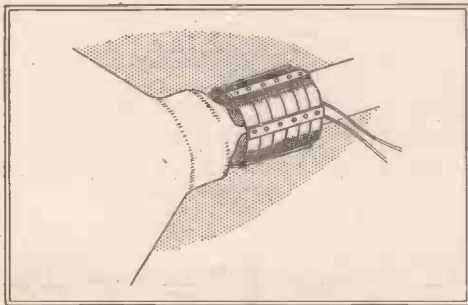

Fig. 8.—A complete line deflector unit.

ciency it is necessary to make the deflector unit as long as possible without the centre of the field getting far enough away from the screen to produce "shadowing" troubles.

Normally the focus coil is situated directly behind the deflection system (perhaps spaced slightly away from it). It is only when the tube is very short and the gun is fairly near to the screen that the focus coil affects the length of the deflector unit. If the focus coil is too near the gun, the spot may become too large, and to focus it the coil may require too many ampere-turns to be economical. If it is

therefore necessary to move the coil nearer to the screen, to do this it may be necessary to reduce the length of the deflector unit still further.

The factors which decide the width of the deflector unit and its length along the neck of the tube (and therefore decide the shape of the coils) should now be fairly clear.

Having already obtained a suitably uniform deflecting field, it is important not to distort this field when the iron circuit is added. (It will be found that the efficiency of the deflector is very considerably increased by enclosing the coils in a suitable iron circuit.)

If an iron circuit that is internally symmetrical is used, very little distortion of

the field will be produced. One type of iron circuit used is in the form of two built-up shells, comprising a series of laminations bent into two semi-circles. These two shells fasten round the coils, leaving about 1/4 in. gap between them above and below so as not to short-circuit the flux across the frame-scanning deflector. A line deflector assembly of this type is shown in Fig. 8.

Another type of deflector unit uses laminations shaped as in Fig. 9 (b). Two small piles of these laminations are butted together and the deflecting coils (both line and frame) are fixed inside the iron circuit. This type of deflector unit is shown in Fig. 9 (a).

It is not possible to give much informa-

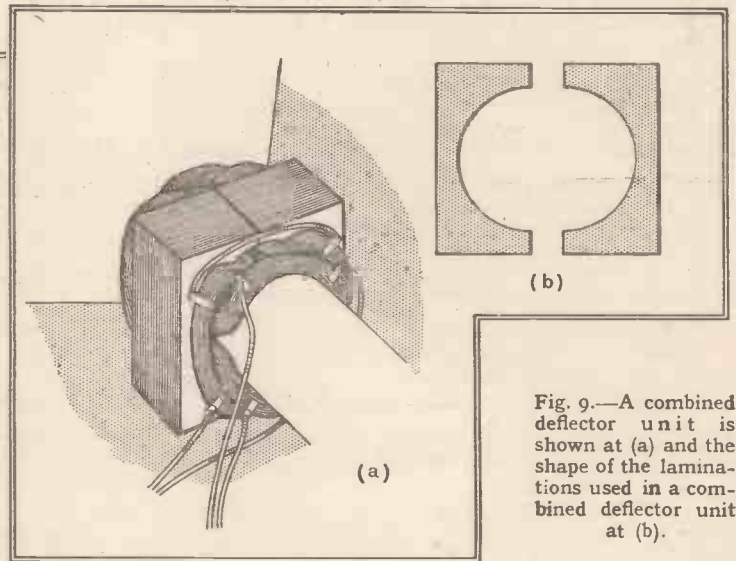

Fig. 9.—A combined deflector unit is shown at (a) and the shape of the laminations used in a combined deflector unit at (b).

tion in the way of winding data for the coils used in the line-scanning unit, as the number of turns and the wire gauge are mainly determined by the type of circuit in which it is to be used.

In the case of the type of unit shown in Fig. 8, when fed directly off a tapping on an oscillator transformer, something like 400 turns of No. 28 SWG enamelled

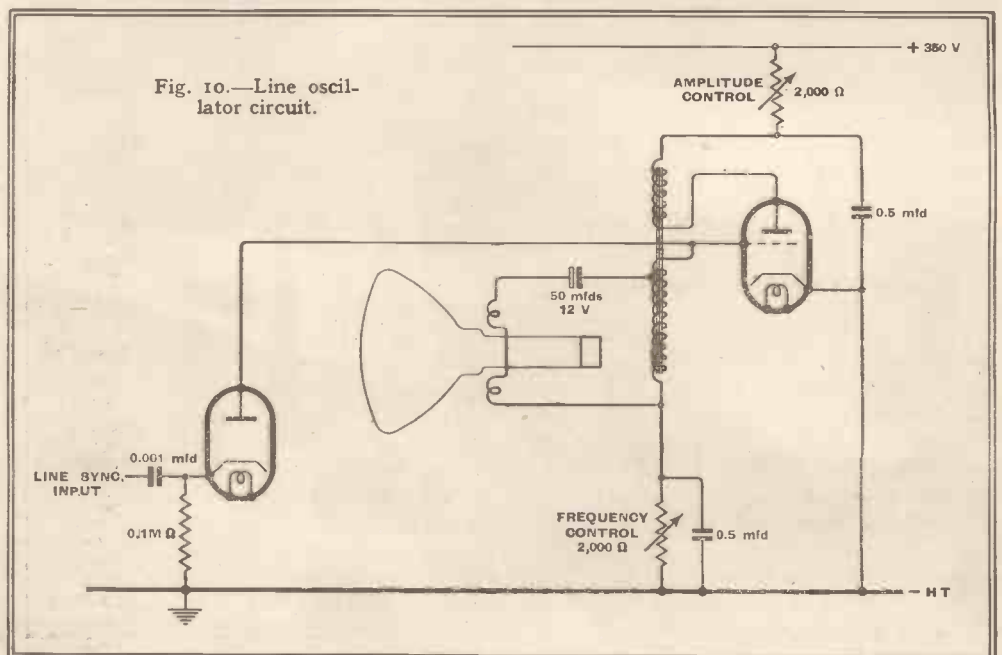

Fig. 10.—Line oscillator circuit.

Line Deflectors

wire (the dimensions depending on tube neck diameter, tube length, etc.) should be fairly easy to match satisfactorily into an oscillator circuit. Fig. 10 shows the general layout of an oscillator circuit that may be used in conjunction with

this type of deflector for line scanning. Data is not given on the design of the transformer, as it is felt that this subject is rather outside the scope of the article.

In conclusion, the author would like to express his thanks to Baird Television, Ltd., for permission to publish this article.

In Forthcoming Issues

OUTPUT TRANSFORMERS. An important series of articles on the question of iron distortion originating in the core. Analysis of the problem by the oscillograph and the application of the results to methods of design.

ADDING A BEAT OSCILLATOR. Constructional details for introducing this "communication set" feature in a broadcast receiver.

THE NEW "MAURETANIA." Description of her wireless equipment, including the binnacle type direction finder.

Regimented Listening

CONTROL FROM THE TRANSMITTING END

THE idea of "regimenting" the wireless public, so that they can listen only to such transmissions as are considered to be good for them, is perhaps in keeping with the spirit of the times. It is made possible by the fact that most modern sets are mains-

making announcements of special urgency.

As shown in the diagram (taken from Patent 498192) the broadcast receiver R can only get "juice" from the mains through a contact C which is, in turn, controlled by a small "slave" or watchdog receiver R1. The latter is either kept

permanently in circuit with the mains, or else is intermittently energised each time a small mains-driven disc-motor D closes a contact K. The receipt of a signal by the "slave" R1 closes the contact C to bring the main receiver R into operation, and simultaneously closes a second contact C1 to short-circuit the interrupter disc D.

The arrangement as shown can only respond to one particular wavelength, to which the circuits must be pre-tuned. If, however, the rotating disc D is also arranged to insert

different condensers, successively, into the tuning circuits of both the "slave" and main receiver, the listener can then pick up "authorised" programmes sent out on one or other of several pre-determined wavelengths.

Further relays may be added in order to make it possible for a distant transmitter to "take charge" of the set, so that it is compelled to receive an emergency message. To ensure priority, the message is preceded by a special carrier-wave signal which is modulated at a definite frequency; this "locks" a similarly tuned circuit-closing relay for the duration of the message. At the end of the message a clearing signal, modulated at different frequency, operates a second relay to release the receiver.

PROBLEM CORNER-24

An extract from Henry Farrad's correspondence, published to give readers an opportunity of testing their own powers of deduction:—

Royal View,

Aberdeen.

Dear Mr. Farrad,

Just after the guarantee period of my set ran out it went wrong! The trouble started with crackling sounds that would stop for a while and then go on again. Lately there have been periods when reception has been unbearable—distorted and noisy, with a loud hum.

Knowing that you require some information to work on, I enclose a photo (below) of the back of the set, and I'm afraid I have no circuit diagram, but I have carefully noted one or two things to help you. The valve marked "DD Pen" gets much hotter now than it used to—and that is saying something—so I took it to the shop, where the man was very ready to test it with a new machine he has, in the hopes of selling me a new one, but to his disappointment it was up to the mark.

Then I sometimes use a gramophone pick-up, but the same trouble is present, though I can remove any of the valves except the "DD Pen" without the gramophone music stopping.

Can you tell me what has gone wrong?

Yours faithfully,

Donald McThrifty.

P.S.—Since I replaced the "DD Pen" after its test, results are continuously bad.

What is the most probable cause of the trouble? Before turning to the solution on page 569, try to think it out yourself.

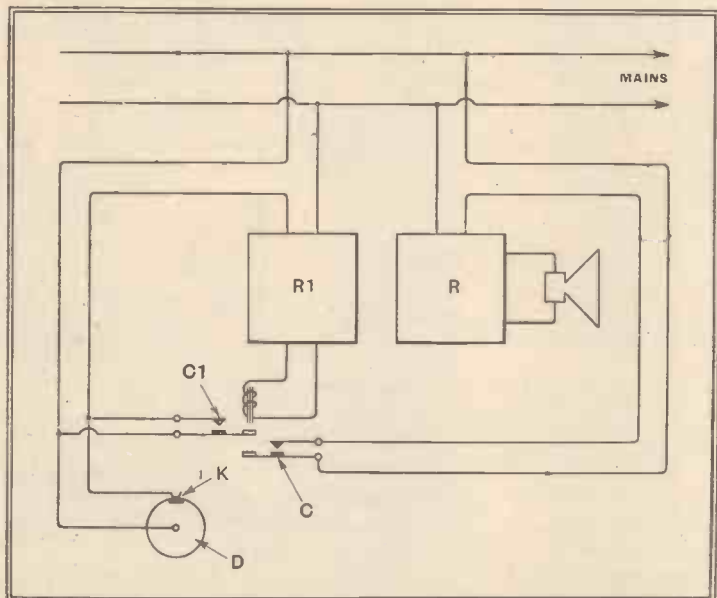

Connections of a "slave" receiver to control the switching on or off of a broadcast set.

driven, so that, in principle, those who have control of the electrical supply can also "call the tune." Provided, of course, that suitable relay arrangements are connected between the set and the mains, and that the grant of a wireless receiving licence is made conditional upon such relays being installed, and, presumably, kept sealed.

Interpolating Announcements

So far we have not reached this stage in practice, though the possibility of some such form of "master-control" will have to be reckoned with in the future. In America, for instance, it has already been put forward as a method of thrusting items of what are called "hot news" on the attention of listeners who may be enjoying some other form of broadcast entertainment. In Europe, under present conditions, it might be used to send out air-raid warnings and, in general, to give priority to the "voice of authority" in



Vertical or Inverted "L" Aerials

THEIR MERITS FOR RECEPTION COMPARED

In this article and its sequel the properties of vertical or "spike" aerial and of the more conventional inverted "L" type are discussed with the object of ascertaining their relative advantages for reception.

By F. R. W. STRAFFORD

THE ultimate object of this article cannot be attained without a fair knowledge of the properties of the radiated waves that constitute radio transmission. With such knowledge we can more easily predict the effects of the waves upon aerial systems of different shapes and sizes.

Most textbooks approach the subject of electromagnetic waves with little mercy on the student, and straight away delve into three-dimensional co-ordinate and differential geometry. The average reader, even if his interest in radio is a serious one, naturally skips these difficult propositions and therefore the electromagnetic wave, as a particular example, remains a mystery.

This is really a pity, because the whole foundations of radio are built upon the unique properties of these waves so brilliantly predicted by Maxwell before they were produced by Hertz and commercialised by Marconi.

An attempt will therefore be made in the opening instalment of this article to approach this difficult subject in a manner which may help the average reader to obtain a clearer mental conception of the processes whereby the electromagnetic wave is established and propagated.

Consider a very elementary transmitting aerial depicted by Fig. 1, consisting of a vertical aerial wire in the base of which is connected a source of high-frequency voltage; for example, the output from a valve oscillator.

The capacity of the aerial to earth completes a high-frequency circuit, and so currents can flow off the wire and return to earth as displacement currents in this capacity.

Now every current is accompanied by a magnetic field which exists inside the conductor itself and extends away from the outside into infinite space.

The strength of this magnetic field is greatest at the surface of the conductor, and naturally falls away as one recedes from it.

Both the current and the magnetic field

close to the wire are in exact phase, so that when the current passes through zero, as it must do twice every cycle of alternation, the magnetic field likewise becomes zero at the same time.

Now we learn from our textbooks that energy is stored in the magnetic field due to the current, and when this current becomes zero and the magnetic field likewise zero, the whole of the energy is restored to the circuit from which it was initiated. Now this is not strictly true—in fact, it is quite untrue when the alternations of current are extremely rapid, as, for example, at radio frequencies, so in other words, although the percentage of energy which is not returned to the circuit is negligible at low frequencies, and may therefore be regarded as a second-order effect, it becomes of paramount importance at radio frequencies, where it changes to one of first order and constitutes the basis for the whole of radio communication.

If we consider a point at a considerable distance from the aerial wire of Fig. 1, it is quite clear that when the magnetic field is maximum close to the wire, i.e. when the current is at maximum, it cannot be quite at a maximum at the distant point. It is a matter of experience that there is no such thing as instantaneity in any natural or physical effect, so that the establishment of the magnetic force at a distance must take a finite time even if it is a fraction of a millionth of a second.

We now approach a little closer to our conception of the electromagnetic wave. When the aerial current falls to zero twice per cycle, only that energy fairly close to the wire is restored to the circuit. The more distant energy is, so to speak, rather late off the mark and finds itself faced with a lone existence. Hence it travels outwards as

a self-maintaining phenomenon and continues to travel even when the current in the aerial is ultimately switched off. Thus we see that, divested of its mathematical rigour, the radiated electromagnetic wave



which constitutes the means for radio communications is defined as that proportion of the energy of the field associated with a current which is not restored to the circuit when the current is removed.

The thoughtful reader will at once exclaim, "If this electromagnetic field is dissociated from the normal magnetic field, why should it alternate, and in particular why should it alternate at the original frequency? Surely, once it passes through zero intensity, there is no reason why it should be re-established since the cause has been removed."

This is a very intelligent and logical question, and the answer to it should complete the student's mental picture of the whole process.

When a magnetic field is changing in intensity with respect to time it will generate an EMF in any circuit it threads. That is to say, if the edges of this paper were formed of a continuous conductor an alternating magnetic field acting through the paper would produce a current round its edge. This is equivalent to saying that

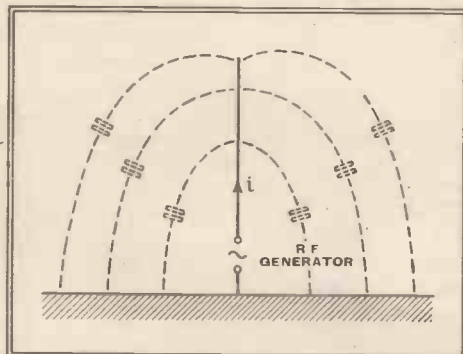

Fig. 1.—A simple transmitting aerial. The aerial current i causes displacement currents to flow through the distributed capacity of the aerial.

Vertical or Inverted "L" Aerials—
an EMF has been created in the conductor and as a result a current flows.

But there is nothing in our elementary textbooks which tells us that the EMF is still there when the conductor is removed. The fact remains that it is there, and further, a current flows round any path whether a conductor is there or not, providing the magnetic field is alternating and threads through that path. These currents are called displacement currents.

Reviewing the position so far, we see that the alternating magnetic field which has started a lone existence collapses to zero, but in collapsing creates an EMF at right angles to its direction of force and a displacement current flows. Now all currents produce a magnetic field, hence a displacement current produces a magnetic field which likewise collapses and creates a further EMF, and so on *ad infinitum*. Hence the magnetic field cannot just vanish, because in attempting to do so it re-creates itself.

This whole process must continue at the rate at which it was initially commenced; hence the frequency of the electromagnetic wave is identical with the frequency of the current in the transmitting aerial.

The wave itself is propagated at the velocity of light, and is capable of absorption, reflection and refraction in just the same manner as light waves. In fact, it has been well established that light waves are purely electromagnetic in their nature, the only difference from radio waves lying in their extremely short wavelengths, which, so far, has been unobtainable by conventional high-frequency generators.

We see that the wave comprises two components: first, a changing magnetic field, and, secondly, an electric field constituted by the displacement current. Neither can exist without the other, and the elimination of one eliminates the other. In fact, one is purely a manifestation of the other, rather like the famous Dr. Jekyll and Mr. Hyde.

Thus, if the direction of travel of the wave is from left to right across this page, the magnetic force acts into the page and perpendicular to it, while the electric force acts from top to bottom. Stated more scientifically, the magnetic and electric components of the wave are in space quadrature and in time phase.

If a magnetic pole (if such could be obtained) and an electric charge were suspended in the path of an oncoming wave, the magnetic pole would rock from side to side, while the electric charge would rise and fall, and they would be in step, one with the other.

If the wave is propagated so that the electric force is perpendicular to the earth, it is said to be vertically polarised. Horizontal polarisation is thus self-explanatory. The polarisation may also lie between these two extremes, and invariably does so in practice.

If we attempt to transmit a horizontally polarised wave over a highly conductive surface—for example, the earth—we fail because the electric force cannot exist parallel with and close to the earth's sur-

face, since this surface must be regarded as equipotential, or, in other words, an electrical short-circuit to the field. Hence, excepting for short waves where the aerials are placed at a distance from the ground comparable with their wavelengths, vertical polarisation is essential for effective transmission.

Now, although the polarisation of a wave transmitted from the simple aerial of Fig. 1 is vertical, it does not follow that at a distant receiving point the same polarisation exists. First, the earth is not a perfect conductor over its surface, and for this reason the wave tilts slightly forward, though the deviation is usually not more than a few degrees, and varies during the travel of the wave according to the conductivity of the earth over which it passes. Hence, there may be quite a sudden change in angle of tilt as the wave

passes over from wet clay to dry sand, or vice versa.

Furthermore, some of the radiated waves which are accidentally (or sometimes deliberately) projected upwards are, as is well known, reflected from the ionosphere, and, apart from suffering absorption in this process, may have their polarisation markedly changed, so that the component of the wave reflected back to the earth's surface from the ionosphere may exhibit entirely different polarisation to that initially established in the vicinity of the transmitter.

We are now ready to discuss the effects of these waves on aerials, but it is proposed to give the reader another week to get over the initial shock of this introductory article before proceeding any farther in the matter.

(To be concluded.)

Radial Scanning

AVOIDING THE NEED FOR FLYBACK

IN ordinary scanning systems, when the moving spot has completed one picture it is returned to the top of the raster before beginning the next. This "flyback" movement is controlled by a special set of

been covered. The rotation is steadily progressive, so that no break or flyback movement is required, each picture being repeated once per revolution.

The apparatus used to produce the scanning movements is illustrated in diagram (b) (Patent 492302). A metal strip, S, mounted under tension on a disc, D, is fitted with a small centre cross-bar, B, which is attracted, say, 5,000 times per second by a magnet, M, fed with AC current. The strip S is arranged to have the same natural "twisting" or torsional frequency, which is then maintained by the magnet. A small mirror, L, mounted at the centre of the strip thus throws the scanning-spot of light radially across the picture. Meanwhile, the disc D rotates bodily, say at 25 revolutions per second, this movement also serving, through the pole pieces P, P₁, to generate the 5,000-cycle current required for the magnet M. If the motor is driven from the same mains supply as the transmitter, the problem of synchronisation practically disappears.

The fact that the scanning lines are spaced more closely at the centre than near the margins of the picture is not necessarily a drawback, since it increases the definition where it is most needed. By using two separate scanning discs, the system can be applied to produce stereoscopic effects in television.

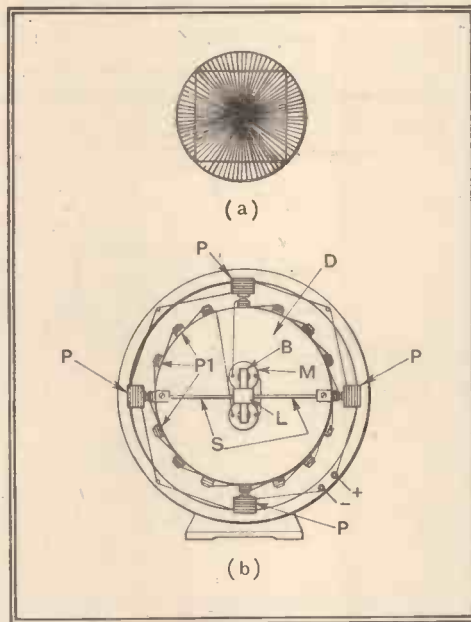

(a) Radial scanning in television reception and (b) apparatus used to produce the required scanning movement.

synchronising signals over and above those required to time each scanning line. So far as the cathode-ray type of receiver is concerned, there seems to be no escape from the use of both "frame" and "line" synchronisation, though there are other systems in which a happier solution has been found.

In diagram (a), for instance, the picture is scanned radially instead of transversely, so that the spot of light swings constantly to and fro through the centre of the picture, its direction being slightly changed at each traverse until the whole area has

WINDING SHORT-WAVE COILS

A Correction

ON page 508 in our issue of June 1st last an arithmetical error occurred in calculating the turns per inch for the coil taken as an example. The denominator should contain the wire diameter as well as the spacing and so becomes 0.0475 + 0.038, which divided into 1 gives 11.7 and not 21.1 as stated.

In view of this it is now suggested that for a coil of 1 microhenry the diameter of the former should be increased to 3/16 in., and applying the design method described it will be found that the 1/D ratio will be 0.895 and the total turns 8 1/2.

Inexpensive Recording Amplifier

FOR OPERATION WITH A STANDARD RECEIVER

By
HUMFREY ANDREWES,
B.Sc., A.M.I.E.E.

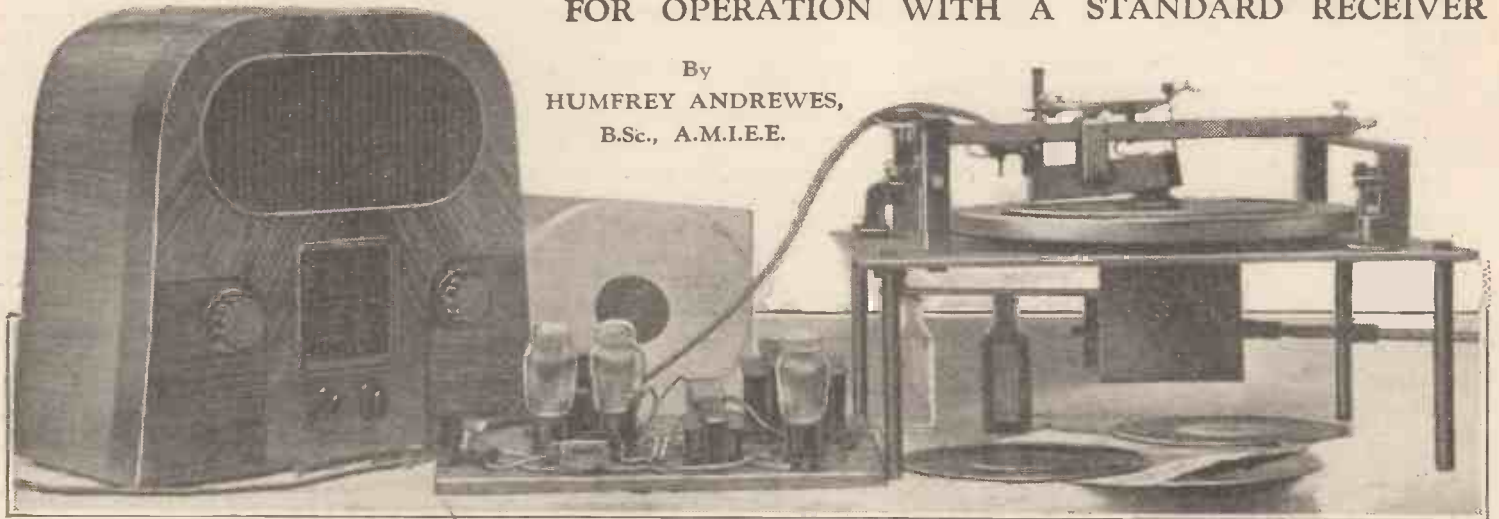

IN the last few years interest in home recording has been growing steadily, but until recently it has been rather an expensive pastime. Not only has the recording blank been expensive, but the experimenter has had to make or purchase additional amplifiers and equipment to work his recording machine. In the last year or so the price of recording machines, record blanks, and other accessories has come down considerably, and sufficient information is now available for the experimenter even to construct his own recording machine. Unfortunately, however, the recording head in which is mounted the sapphire, which makes the actual records, on many machines to-day, particularly those of the better quality, requires considerably more audio power than is available from the average radio set. There are also difficulties in obtaining a satisfactory match between the load of the recording head and the output circuit of the receiver, particularly when a pentode output is used.

The amplifier to be described below has been designed to overcome this difficulty while, at the same time, keeping the financial outlay as small as possible. As a general rule, where a special amplifier is constructed solely for recording purposes, a parallel or push-pull output stage utilising triodes and having an undistorted output of at least 12 watts is used. Such an amplifier is rather an expensive item, and the cost of the power pack and output

FOR reasons given in this article, the majority of recording machines cannot be operated directly from the output of a normal broadcast receiver. The amplifier described is intended to act as a link between the two instruments.

stage is often approximately three-quarters of the total expenditure. It is, therefore, obvious that if a single stage amplifier is used of the same type, as a coupling between the radio receiver and the recording head, no serious advantages will be gained over using a separate recording amplifier, since the same expensive high-voltage power pack will be required.

Fig. 1 shows the circuit diagram of the amplifier designed by the writer. Two

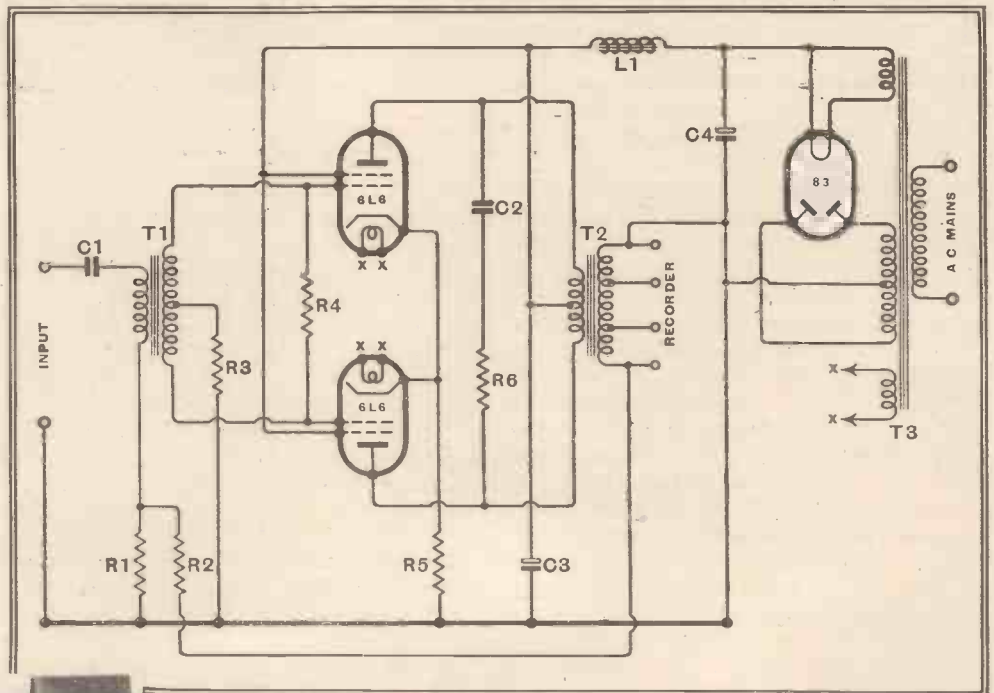
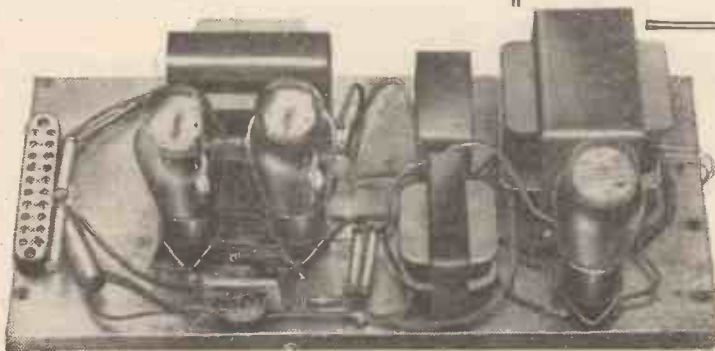

Fig. 1.—Complete circuit diagram of the recording amplifier. Values of components are given in the "List of Parts."

Although the amplifier is of simple design and with few complications, the output is ample for home recording purposes.

valves of the 6L6 beam tetrode type are used in push-pull, and the main advantage obtained by using this type of valve is that the required output of over 12 watts can be obtained with the comparatively low HT voltage of 250. This immediately reduces the cost of the amplifier, as these valves are slightly cheaper than 5-watt triodes and the cost of the mains transformer is almost halved. A midget input transformer is also used, and it will be seen



Inexpensive Recording Amplifier—

from the photo reproduced on the preceding page, which shows an experimental amplifier made up on these lines, that with the exception of the smoothing condensers, which may be of the cheap electrolytic type, this practically completes the components. The photograph also gives a general view of the layout, although in an amplifier of this type this is unimportant and can be varied to suit the experimenter's individual requirements. A complete list of components and the values is given at the end of the article. As the HT current is over 120 mA, and it is very

We thus have an amplifier which has largely overcome the difficulties mentioned at the beginning of this article, and, although the cost has been reduced to a minimum, an output of over 12 watts is available. It is very simple and easy to construct, has an excellent frequency characteristic, and may be used with recording heads having widely varying impedance. Fig. 2, curve A, shows the general characteristic of the amplifier. This shows the curve of the voltage across the terminals of the recording head for constant input to the primary of the input transformer, and it will be noted that the

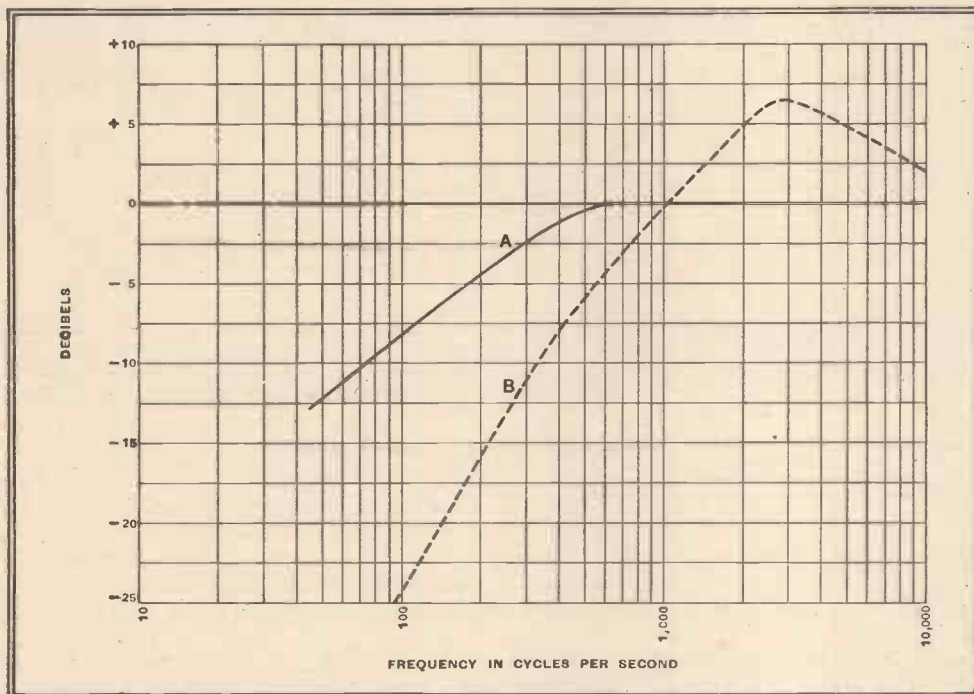

Fig. 2.—The amplifier has the rising frequency characteristic (A) appropriate for gramophone recording. Curve B shows the effect of removing negative feedback.

desirable for this type of valve (6L6) that the regulation of the HT supply should be good, an American 83 type rectifier is used. This is of the mercury vapour type and has a very low impedance. A special output transformer was used which had tapings so that recording heads having different impedances could be used.

If output valves of the 6L6 class are used in a straightforward push-pull circuit to feed a recording head of the balanced armature type, owing to the rising curve of the valves and the variation in the impedance of the recording head, a very poor frequency characteristic results. For this reason it will be observed, on examination of Fig. 1, that considerable negative feedback has been introduced by connecting one side of the secondary of the output transformer to the earthy end of the primary of the input transformer by means of a suitable potentiometer. In order to ensure stability a 100,000-ohm resistance is connected between the control grids and a resistance of the same value between the centre tap of the input transformer and earth. A resistance condenser filter is also connected between the anode for a similar reason. In other respects the amplifier follows the conventional practice.

usual rising characteristic has been introduced from 50 to approximately 500 cycles, and that above this frequency the curve is flat within plus or minus 1 db. Readings were not taken beyond 10,000 cycles as the range covers normal recording requirements. It is reasonable, however, to suppose that the curve would remain flat to considerably higher frequencies. In order to illustrate the advantage gained by the use of the negative feedback, curve B was plotted with the negative feedback potentiometer disconnected. It will be seen that there is an enormous difference, as not only is there a considerable loss of the low frequencies but a marked resonance hump around 4,000 cycles. These curves were taken with an input impedance of 10,000 ohms. If this value is varied the value of the input coupling condenser (a value of 0.25 mfd. is shown) will have to be altered to obtain the correct low-frequency characteristic. No input volume control has been included, as it is assumed that the amplifier will be connected to the output of a receiver and that the normal volume control will be used. The output impedance was approximately 3,500 ohms at 1,000 cycles, but, as explained above, taps were provided on the transformer so that

other values of impedance can be used. In the case of the recording head used for these experiments a maximum of approximately 150 V. RMS was required across the recording head at 1,000 cycles, and to obtain this the input voltage was 15 V. RMS. It is interesting to note that when negative feedback was used 1.75 V. were required to give the same output, showing that negative feedback reduced the gain of the amplifier to about one-eighth.

On test the amplifier was found to give excellent results and could be easily operated from a small table model commercial receiver by simply connecting the input terminals across the loud speaker transformer primary of the set. Although in certain models it may be found desirable to disconnect the loud speaker, in the particular receiver in which the tests were made this was found quite unnecessary, as the full output from the recording amplifier was obtained when the set was run at quite a moderate level. In order to check the quality of the recording from this amplifier under the best possible conditions, it was fed from the penultimate stage of elaborate recording amplifier in which two large triodes in push-pull were normally used. Recordings were made from the inexpensive amplifier and from the normal equipment using the same recording head. On replay it was extremely difficult to distinguish between the two recordings. The flat characteristics of the inexpensive amplifier gave a recording in which the higher frequencies were very faithfully reproduced and there were no signs of distortion in the lower frequencies.

It will be noted that no milliammeter has been provided in the HT feed as it was desirable to keep the cost down as low as possible. A cheap meter may, of course, be added and serves as a useful indication of the maximum level at which the amplifier may be run without distortion. At a later date a proper volume level indicator may be purchased, if it is desired to obtain accurate indication of the output voltage peaks.

It is hoped that this brief description of an inexpensive amplifier will help to increase the popularity of home recording, and dispel the idea that good results can be obtained only by the use of elaborate and expensive apparatus.

LIST OF PARTS

- 1 Mains Transformer (Special), T3 Partridge
- 1 Smoothing Choke 8 henrys (Special), L1 Partridge
- 1 Output Transformer (Special), T2 Partridge
- 1 Push-pull Input Transformer, T1 Bulgin Midget, Type LF36
- 1 Resistance 40,000 ohms, ½ watt, R2 Erie
- 1 Resistance 2,500 ohms, ½ watt, R1 Erie
- 2 Resistances 0.1 megohm, ½ watt, R3, R4 Erie
- 1 Resistance 10,000 ohms, 1 watt, R6 Erie
- 1 Resistance 125 ohms, 2 watts, R5 Erie
- 1 Smoothing Condenser 8+8 mfd., C3, C4 T.C.C.
- 1 Condenser 0.001 mfd., C2 T.C.C.
- 1 Condenser 0.25 mfd., C1 T.C.C.
- 2 Valve holders, Octal Premier
- 1 Valve holder, 4-pin American type Premier
- 2 Valves Type 6L6 Premier
- 1 Valve Type 83 Premier

Start Point

100 kW
1050 kc/s
285.7 metres

Technical Details of the Main Transmitter in the B.B.C.'s New West Regional Scheme

THE problem confronting the Engineering Division of the B.B.C. in providing the West of England with a Regional programme of adequate strength has proved to be one of no little difficulty. From the point of view of wave propagation the qualities of the sub-soil in the Dartmoor area, which would otherwise have provided an ideal site in the geographical centre of the region, are so poor that a power which would give a certain specified signal strength at a distance of 20 miles in this district would produce the same field strength at 60 miles in normal country or at 200 miles over the sea.

Accordingly, it was decided to move the site of the main station to Start Point, where the path of transmission to most parts of Cornwall and the South Coast would be over the sea. The North Devon coast and those parts of Somerset which lie under the "shadow" of Dartmoor would then be irradiated by a subsidiary station at Clevedon—again operating with the advantage of propagation over the sea to the more remote parts of the district.

The scheme, while providing the required field strength over the whole area, would be open to serious objection on the score of efficiency if power were expended in projecting an equal field strength over the English Channel where ships may be numerous, but revenue from licence fees would be small. This objection has been overcome by the use of a special aerial

General view of the station buildings and the twin mast radiators.

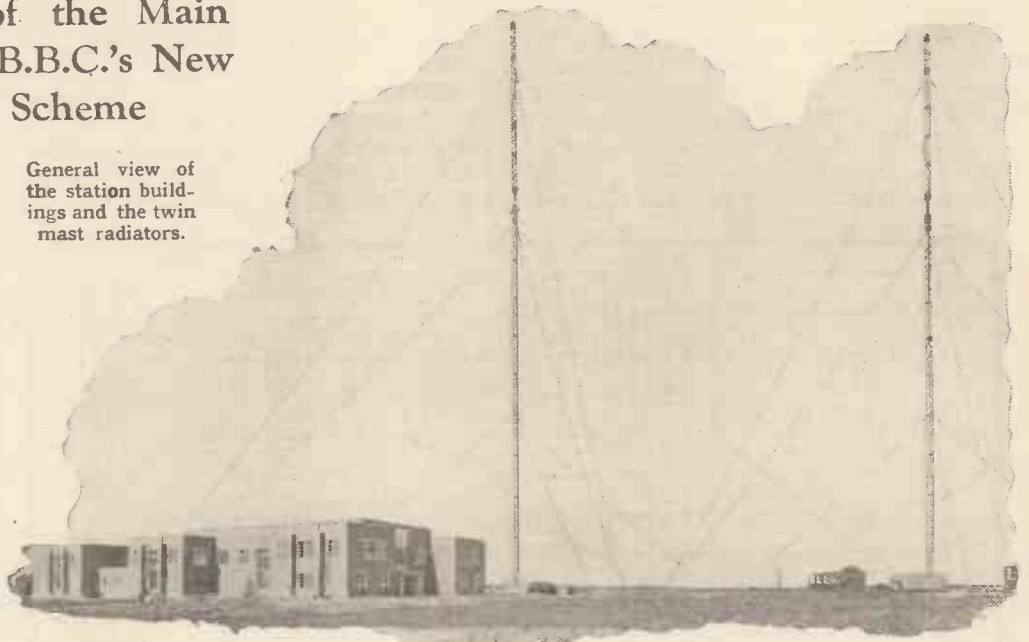

system which is technically one of the most interesting features of the station.

Two steel masts, erected by the J. L. Eve Construction Co., act as radiators. They are both 450ft. in total height and their bases are spaced approximately three-eighths of a wavelength apart. Both are energised by the transmitter, one directly and the other through a phase-shifting network. The principle is thus quite different from that of the quiescent type of reflector such as is used in the familiar television receiving aerial. By adjusting the constants of the network feeding the second mast, the polar diagram of radiation can be considerably modified and has in fact been carefully

adjusted during the initial test period not only to reduce radiation to the South, but also to give an increase in both an easterly and westerly direction.

The masts stand on insulators of the compression type and a second insulator has been introduced in each mast at a height of 310ft. from the ground. The current is fed into the 140ft. top section through a variable impedance bridging the insulator. By adjustment of this impedance the polarisation or angle at which the greater part of the energy in the wave leaves the aerial has been arranged to increase the distance at which interference between the ground and sky waves are likely to introduce fading effects.

The usual aircraft warning lights are fitted with RF filters in the supply circuits. Three groups of three stays spaced in planes at 120 degrees support the masts, the intermediate stays being attached about 20ft. below the insulated gap.

Protection from Lightning

The aerial couplings circuits are housed in small buildings at the base of each mast. The one nearest the transmitter contains the phase-shifting network. Concentric feeders supplied by Marconi's Wireless Telegraph Co., Ltd., are used to "pipe" the modulated RF energy between the transmitter and the coupling circuits. All the circuits are duplicated and a relay system is included to protect the equipment in the event of a temporary "earth" due to lightning. The relay is arranged to break momentarily the main anode HT supply and to warn the staff by an indicating lamp when the relay operates.

The main transmitter and valves were supplied by Standard Telephones and Cables, Ltd., A spare for any valve can-

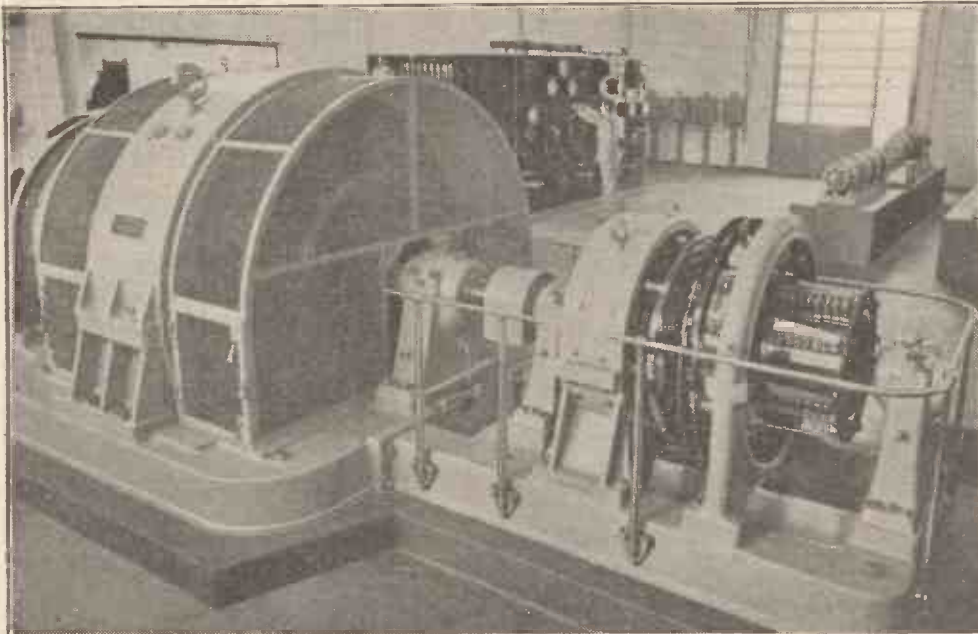

One of the 14,000-volt main anode HT generators in the machine room. Coupled with it is the main filament generator which produces 2000 amperes at 28 volts.

Start Point—

be brought into circuit by switching and the transmitter circuits together with their valves are housed in a sub-divided metal enclosure through which meters and other units may be seen. The meters incidentally were supplied by Ernest Turner Electrical Instruments, Ltd. All enclosures containing high-voltage apparatus are protected by an electro-mechanical system of interlocks and cannot be entered while the high-tension supply is connected.

Frequency control of the carrier wave is better than one part in one million and the master component is a high-precision quartz crystal. Special attention has been given to temperature regulation and the thermostatically controlled chamber for the crystal is installed together with all other apparatus associated with frequency control in a separate room above the programme control room. A standby crystal control is built into the transmitter itself and there is also a reserve unit consisting of a master valve oscillator which is used in conjunction with a special tuned circuit of high stability which is itself thermostatically controlled.

Including the modulated output stage there are four stages in the RF section of the transmitter. The first and second stages make use of single tetrodes, the third employs a water-cooled triode and the output stage, four water-cooled triodes in parallel push-pull. In the audio-frequency amplifier triodes are used in push-pull for each of the four stages. Air-cooled valves in the first and second stages are followed by water-cooled valves in the third and fourth stages.

"High Power" Modulation

Modulation is carried out under Class "B" conditions at high power level in the final stage and negative feed-back is employed. As a result the total harmonic content even up to 90 per cent. modulation does not exceed 2.5 per cent. Another advantage of this system, which has been adopted in all recent B.B.C. stations is the high overall efficiency which can be attained—an important consideration where power consumption represents the major item in the operating costs of the transmitter. An interesting consequence of high level modulation is the size assumed by the modulation transformer. This component, which was supplied by the Foster Engineering Co., Ltd., measures 6ft. by 3ft. by 8ft. 6in.

The modulated RF output is controlled by a three-position switch leading to either of the duplicate concentric feeders or to a water-cooled artificial aerial circuit for preliminary adjustments of the transmitter "off the air."

The water cooling system for the valves is interesting. It is a closed circuit in which distilled water is circulated by two pumps in parallel. In the event of failure of one pump the other is capable of taking over the full load without the need for even a momentary stoppage of the water supply. Meters are included to indicate

the rate of flow and the temperature gradient in the circuit. On the roof of the building forced-draught coolers are installed in duplicate. The heat transferred to the airstream is not wasted, but can be used to supplement the normal heating arrangements of the station during cold weather. The whole of this side of the installation has been carried out by Rosser and Russell, Ltd.

The main power supply is taken, under normal operating conditions, from the Borough of Torquay Electricity Undertaking at a pressure of 11,000 volts. There are two incoming cables and transformers rated at 500 kVA and designed to reduce the three-phase, 50-cycle supply to 440/250 volts.

As is usual at all main stations of the B.B.C. there is a stand-by generating plant with a reserve fuel oil capacity of 80 tons to enable transmission to be carried on in the event of failure of the public supply. The prime mover is an eight-cylinder, airless-injection horizontal-type diesel engine by the Brush Electrical Engineering Co., Ltd., giving 600 h.p. at 330 r.p.m. It is coupled directly to a 400-kW (0.8 power factor) alternator which generates 440/250 volts, 3-phase at 50 cycles. Meters for synchronising the alternator with the main supply in order that a change-over may be effected without interruption are provided on the main switchboard in the Power House.

Two auxiliary 30-kW, 220-volt DC motor generators are also installed in the Power House. Their function is to supply current for the transmitter interlocking circuits and to charge the 220-volt, 500 ampere-hour storage battery. The battery which is by the Hart Accumulator Co., Ltd., is housed in a separate room and is used for stand-by lighting and for the auxiliary equipment of the diesel engine.

The HT, filament and grid bias supplies to the transmitter are provided by three motor-generator sets in the Machine Room. Each generator is duplicated, one machine in each pair being held in reverse.

The main anode HT generator for the final RF and modulator stages is a 14,000-volt machine made by the English Electric Co., Ltd. It has an output of 400 kW and to the same shaft is coupled the

main filament generator supplying 2,000 amperes at 28 volts.

The auxiliary anode HT generators made by the Electric Construction Co., Ltd., consist of two machines in tandem delivering 1 amp. at 2,600 volts and 1 amp. at 1,200 volts DC. The same firm has been responsible for the grid bias and auxiliary filament sets which comprise three generators in tandem. The filament generator gives 80 amperes at 13 volts and the two grid bias machines are rated at 500 volts, 0.75 amp. and 325 volts, 5 amps. respectively.

The general design and layout of the station follow the lines adopted in other B.B.C. Regional stations. In addition to the rooms already mentioned there are a Control Room where the incoming programme over the land line from Plymouth and the general SB network is adjusted and if necessary corrected for frequency response, a quality checking room and studio for emergency use and the usual staff mess-room, valves stores, etc.

The main building is 256ft. long, 92ft. at its maximum width, and 29ft. high. Fears expressed in some quarters that the



Transmitter Hall as seen from the gallery. The transmitter is on the right and the modulation transformer and plate feed reactors are in the cubicles at the left of the picture.

new buildings might prove an eyesore on an unspoilt stretch of coastline have been allayed by the choice of a buff-toned brick which harmonises well with the surrounding landscape.

Every detail of the new station has been thought out and executed with the B.B.C.'s customary thoroughness. Even the minor problem of the main entrance to the building has been given due consideration, and a revolving door takes the place of the usual hinged doors which might give trouble in the high winds which are often experienced on the headland.

UNBIASED

Alice in Wonderland

I ALWAYS recollect, soon after I was married, trudging along a country road on a hiking tour with Mrs. Free Grid, and coming at eventide upon an old-world country hostelry. My eye was struck by the peculiar aptness of the hanging sign which proclaimed that within was to be found refreshment for man and beast, and, naturally, I promptly led Mrs. Free Grid into its inviting portals. To my intense surprise I found that mine host was none other than a very well-known advocate of temperance, and I delivered myself of a few well-chosen

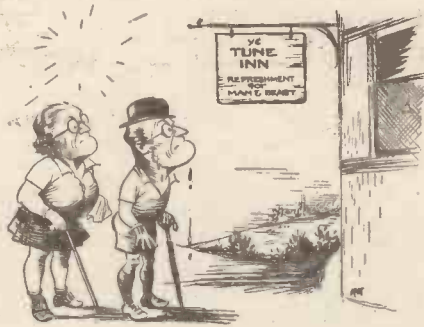

I promptly led her in.

words of rebuke on the subject of the evils of hypocrisy.

Instead of being abashed, however, the landlord pointed out that it was quite evident that I had mistaken the meaning of the word temperance, and was confusing it with teetotalism. True temperance, he explained, meant taking a moderate amount of everything, neither drinking to excess nor rushing to the opposite extreme of being intemperate in abstinence by taking too little. Struck by the soundness of his views, I spent the evening taking a moderate amount of everything which his cellar contained, and since then I have always been an ardent advocate of temperance.

This old experience was all brought back to me with a rush the other day when I came across yet another instance of what I cannot help thinking is suspiciously like hypocrisy, although I am probably all wrong. Briefly, an acquaintance of Mrs. Free Grid has recently acquired a brand new vacuum cleaner which, whatever its cleansing capabilities may be, certainly produces the most appalling interference to neighbouring wireless sets.

Being deputed to wait upon the good lady, and tender her certain advice as they say in the law courts, I was astounded to learn that she was an ex-employee of a very well-known wireless firm, and that this vacuum cleaner was given to her as a parting gift to speed her on her way. She was quite willing to have the apparatus attended to, but

sat heavily upon me when I ventured to criticise her late firm for what I told her was nothing more or less than preaching temperance on one hand and selling beer with the other.

"I do not claim to be an authority on beer; that is probably more in your line," she said, rather tartly, "but I do know that there must be some proper explanation of what admittedly appears to be a sort of Alice in Wonderland business." The good lady was obviously so much in earnest that I retracted my words and apologised, and am beginning to wonder if, after all, there is not some simple explanation of this apparent anomaly just as there was in the case of the temperance business which I have related to you. Perhaps you can help me? Meanwhile, I have silenced the offending vacuum cleaner temporarily with a hammer until I can find time to deal with it more scientifically.

Theory and Practice

A LION tamer I once met used to be loud in his claims that the human eye possessed the power to quell any animal and make it halt in its stride. He was, however, very loth to accept my invitation to spend a night in the fleas' den at the Zoo. Certain wireless theorists remind me of him, as although they loudly proclaim that, owing to the "skin effect," HF can't hurt no matter how high the voltage, they seem extraordinarily reluctant to put their views to the test by grasping the aerial of a transmitting station when it is in action.

June in January

I SUPPOSE that, like myself, a good many of you are faced with the prospect of a very bleak and cheese-paring time this summer as the result of disastrous investments at Ascot. I very nearly lost the proverbial shirt in actuality, as I discovered at the end of the first day that I had not enough to pay my return fare home. I was, in fact, seriously wondering whether I could raise a loan on my much-repaired shirt and—pardon me, ladies—*culottes de dessous* when I was offered a lift by a kindly disposed bookmaker.

In the course of our journey in his sumptuous car our conversation ranged over many things and, naturally, drifted to wireless matters. When he learned that I was connected with *The Wireless World* he insisted on taking me home for the night, as he had, he alleged, something which ought to interest me greatly. He dwelt, I found, in one of the stately homes of England, suitably situated in delightful grounds, and I had a thoroughly enjoyable time, so much so that I fear we never touched wireless subjects at all, and

By FREE GRID

it was only after I had left the house in my dressing gown during the stilly watches of the night in order to take a solitary midnight ramble in his beautifully wooded grounds that I rather guiltily remembered the object of my visit.

I had rambled some little distance listening to the glorious singing of the birds, in which I readily distinguished the notes of the blackbird, the cuckoo, the screech owl, and a host of other summer songsters, when it suddenly struck me that it was a most extraordinary thing that these birds should be singing at 1 a.m., and I hastened back to the house as it occurred to me that with our foolish English method of reckoning time by two daily periods of twelve hours instead of one of twenty-four, I did not really know whether my watch indicated 1 a.m. or 1 p.m. True, it was dark, but I had a vague recollection of reading something in the newspapers about a total eclipse of the sun being expected, and that, of course, would explain everything.

When I reached the ancestral mansion, I found the drawbridge raised and the portcullis lowered and knew at once that it was really night, and it was not until the morning that I learned the true explanation of my extraordinary adventure. My host, it appeared, had read some time



Off in the stilly night.

ago in my notes of the man who had put microphones in the branches of the trees in the woods around his estate, in order to gather all the vocal efforts of the birds into one glorious medley of song, this being fed through an amplifier to a loud speaker in his library.

My present host had, however, been struck by the utter desolation and silence of the woods throughout the long winter days and also in the stilly watches of the summer nights. He had, therefore, merely reversed the process by putting the loud speakers in the trees and the microphones into a large aviary which he had built and equipped with permanent artificial sunshine so that his woods were at all times filled with song.

NEWS OF THE WEEK

START POINT AND CLEVEDON

A Regional Service for the South, not Forgetting the Channel Islands

THE opening of the Start Point and Clevedon transmitters by the Duke of Somerset yesterday afternoon is calculated to bring a B.B.C. Regional service to three million listeners along the South Coast from Cornwall to Sussex, as well as to the whole of Dorset and the southern parts of Wiltshire, Somerset, Devon and Cornwall.

The 100-kW transmitter at Start Point has taken over the West Regional wavelength of 285.7 m., freed by the closing of the 50 kW Washford transmitter. The 21-acre site occupied by the station, chosen after prolonged tests with a mobile transmitter, enables advantage to be taken of transmission over the sea, over which attenuation is low. The two 450-ft. insulated mast radiators are designed to give a maximum radiation to the East and West, and some doubt has been raised by listeners in the Channel Islands as to the quality of reception that may be expected from the transmitter. In reply, the B.B.C. is anxious to point

out that, while the station is primarily intended to provide a service to the South-West of England and the South Coast, a reasonably satisfactory service should be available to listeners in the Channel Islands.

The aerial system employs a so-called "reflector," and is so arranged as to reinforce the strength of reception in the East and West directions. It has no effect on radiation to the North, but radiation over a narrow arc, the centre of which bears 159° from Start Point, is reduced. This should not adversely affect reception in the Channel Islands to any appreciable extent, and, due to the path from Start Point being almost entirely over sea, a good signal by the direct wave should be available.

When the new wavelength agreement comes into effect in the autumn the transmitter's power will be raised to the new maximum of 150 kW, and this will help to stabilise reception in the more remote parts of the service area.

The 20-kW Clevedon transmitter, which was opened at the same time as Start Point, is designed to serve areas around Bristol and the North and West parts of Somerset which cannot be

CLEVEDON'S 375-ft. mast radiator is surmounted by a hinged capacity ring, the diameter of which can be altered according to the operating wavelength.

satisfactorily covered by Start Point. It will radiate the same programme as the bigger station, using the old Bournemouth wavelength of 203.5 metres.

The Bournemouth and Plymouth transmitters, which closed down with the inauguration of the two new stations, had been opened on October 17th, 1923, and March 28th, 1924, respectively.

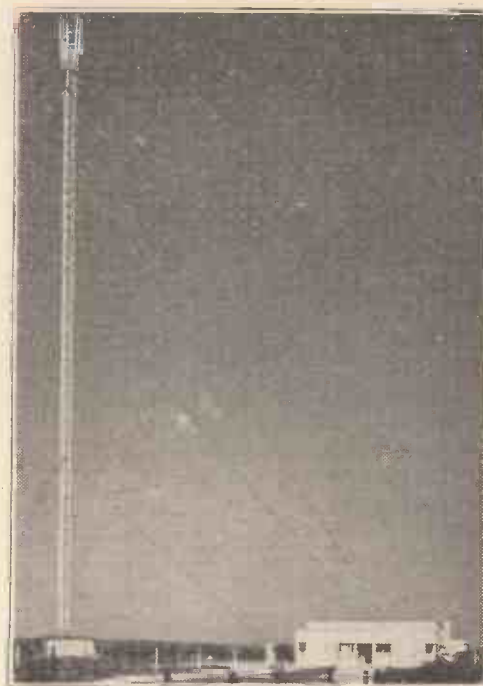

TELEVISION NETWORK

Four More Transmitters for Germany

IN addition to the three television transmitters already built or under construction, in Berlin, on the Brocken and on the Feldberg, the German Post Office has decided to erect new transmitters at Munich, Nuremberg, Hamburg and Vienna. Preliminary tests are taking place at Hamburg, and it is probable that the Hamburg transmitter will be housed in the high building from which these experiments are being conducted.

The range of the Berlin transmitter is stated to be only 12 miles at the present time, but during 1940 the range of the station will be increased to about 35 miles. A new television studio building is being constructed in the meantime, on the extreme western outskirts of Berlin.

The Brocken transmitter will shortly commence test transmissions, but the station will not be ready for operation until the end of the year. The Feldberg transmitter is not yet completed.

The German Post Office proposes to link up the various television transmitters by cable, and work is proceeding in this direction. A central television programme will be supplied from Berlin for all stations.

The official introduction of a public television service for Berlin has been promised for this year.

WELCOME HOME

The Royal Party to be Televised

WE understand that arrangements have been completed for broadcasting and televising the homecoming of the King and Queen on June 22.

All stations of the B.B.C. will

TELEVISION EXPORTS

Questions and Answers in the House of Commons

THE Postmaster-General was asked by Sir Edward Grigg in the House of Commons last week whether, in view of the fact that we now had in prospect a market for the export of television instruments, which might be lost by delays in the extension of television at home, he would do his utmost to expedite a decision on the question of transmission which was being investigated by the Cadman Committee.

Major Tryon, the P.M.G., stated in reply that the Television Advisory Committee was actively engaged in investigating alternative methods of extending the television service beyond the London area, but he had not yet received a report on the subject. He said that he was satisfied that the Committee was fully alive to the considerations to which Sir Edward had referred. Representatives of the Radio Manufacturers' Association had, he said, submitted evidence to the Committee concerning the extension of the television service, and he had himself recently received a deputation from the Association on the subject.

HONOURS

THE order of Knight-Commander of St. Michael and St. George is conferred upon Mr. Edward Wilshaw in the Birthday Honours List. Mr. Wilshaw has been Chairman and Managing Director of Cable and Wireless since June, 1936.

Mr. Derek McCulloch, B.B.C.



Mr. Edward Wilshaw.

Director of the Children's Hour, and famous as a radio "uncle" since 1929, receives the Order of the British Empire.

BAIRD TELEVISION COURSE

Training for Cinema Projectionists

A SERIES of free instructional courses for cinema television projectionists is being given by Baird in a specially adapted section of their factory at Sydenham. The course entails daily attendance for a fortnight; the next session begins on June 19th.

Four lecturers, each expert in his own particular field, will teach the theory and practice of big-screen television, and at the end of the two-weeks' course the students will undergo a test.

"RADIO EARS" OF SOUTH AFRICA

ON a picturesque site, fourteen miles from Johannesburg (says the Johannesburg Star), a building is to be transformed into the Union's "radio ears."

Although relays of overseas programmes will be the main purpose of the diversity station, it will be able to provide reports on the Union reception of foreign broadcasts, keep a check on South African stations, and prove of potential importance in Union defence. Consideration is also being given to the possibility of undertaking wavelength measurements.

News of the Week—

relay a commentary from Southampton Docks between 3.10 and 3.30 p.m. London's welcome will be broadcast at 5.25, when the Royal Party reaches Waterloo, and commentators will be stationed at the terminus, at Big Ben and outside Buckingham Palace.

Television cameras will occupy the same positions at Waterloo as on the departure of their Majesties, but improved positions have been found for the cameras outside Buckingham Palace. The mobile unit will be stationed to the south of the Victoria Memorial.

Telephoto lenses will give close-ups of the King and Queen and members of the Royal Family on the famous balcony.

APPLAUSE FILTERS?**The Need for Control**

TECHNICAL methods of reducing the applause broadcast in such programmes as Music Hall and the Queen's Hall concerts may be resorted to following a growing correspondence from home and overseas listeners, who complain that too much applause is irritating and prejudicial to good reception.

Applause control may soon play a much more important part in the B.B.C. transmissions, with an engineer manipulating gain on the audience microphones throughout the performance. At one time it was considered that the audience might be reminded to repress its feelings, but it is felt that this would kill the freshness and spontaneity of the broadcasts.

DEMONSTRATION TELEVISION AERIAL**Unusual Application of an Extending Ladder**

AN unusual method of rapidly installing a temporary dipole aerial has been evolved by Griffin Bros., of Leighton Buzzard.

The principle employed is similar to the "Fire Escape" aerial used by the B.B.C. Television O.B. Unit. A dipole aerial and reflector is bolted by means of a swivel bracket to the top of an ordinary extension ladder. It is the work of a few moments to place the ladder against a house and secure the top of the first section to a chimney or gutter. The top section can then be raised by means of ropes from the ground.

Two engineers can have a television receiver operating within about twenty minutes of the time of its arrival at the prospective customer's house, and demonstrations carried out by means of the ladder aerial in the Leighton Buzzard district (45 miles from Alexandra Palace) have been completely satisfactory.

The idea should prove invaluable to wireless dealers who have to tackle the problem of quickly erecting an efficient



Erecting the demonstration aerial.

television aerial for demonstration purposes at a small cost.

**FROM ALL
QUARTERS****L.C.C. School Radio**

THE L.C.C. report on elementary schools for the year ending March 31st, 1938, was issued last week. It states that at the end of the year under review 300 schools were equipped with approved wireless installations.

Guernsey Radio

THE Guernsey Civil Aeronautical Radio station, which was brought into operation on May 8th, has altered its transmitting frequency to 325 kc/s (923 metres) in order to avoid interference with other stations. The station uses the call signs GVE on wireless telegraphy, and announces itself "Guernsey" on radio telephony.

Birmingham Radio

A BIRMINGHAM "subsidiary" radio station, providing communication and DF facilities for radio-equipped aircraft approaching Birmingham Aerodrome, has been recently brought into operation. The station works on the same frequency as Guernsey, 325 kc/s, and identifies itself with the call signs GEX on W/T and "Birmingham" on R/T.

DF at Heston

DURING the reconstruction of the Croydon Airport Lorenz landing approach installation, necessitated by the alteration of the approach line, the radio beacon at Heston Airport will operate on the Croydon frequency of 33.33 Mc/s (9 metres) for the main beacon, and 38 Mc/s (7.89 metres) for the inner and outer marker beacons. The operation of reconstruction at Croydon is expected to take about two months.

Debate on Radio Relays

THE recent decision by the Government to renew for ten years the licences to private radio relay companies, will be debated in the House of Commons to-morrow. The debate will also cover the Post Office wired wireless system recently announced by the P.M.G.

B.B.C.'s Overseas Students

STUDENTS for the B.B.C. training courses continue to be recruited from all parts of the world. In the new half-session which opened last week the list included the station directors of All-India Radio, from Lucknow and Peshawar; two nominees of the Rockefeller Foundation, U.S.A.; and an announcer from the New Zealand Government broadcasting service.

South India Stations

THE Indian Government proposes to install a 10-kW medium-wave station at Wellington Island, in the Cochin State, South India. Such a station would be used largely for official communications. The State of Travancore, also in South India, has ordered from Standard Telephones and Cables, Ltd., a 5-kW medium-wave broadcast transmitter complete with speech input equipment for five studios, and Blaw Knox vertical radiator, to be installed at Trivandrum. The wavelength selected is 455.9 metres. This transmitter will employ air-cooled valves only, and final-stage Class B modulation.

Short Waves from Switzerland

TEST transmissions are now being carried out by the new Swiss short-wave station at Schwarzenburg on the following eight different wavelengths: 49.55, 48.66, 31.46, 25.28, 19.60, 16.87, 13.94 and 11.70 metres.

News for the Czechs

THE first Polish News Bulletin in the Czech language was broadcast from Katowice last week on 758 kc/s (395.8 metres). According to a report in *The Times*, this is said to be the first time since the annexation of Czecho-Slovakia that the people of Bohemia have been able to hear news in their own language except through the home stations controlled by the Germans.

Radio and A.R.P.

AN ultra-short-wave radio telephony transmitter was used last week during Sheffield A.R.P. exercises by Mr. H. Benson, a head warden. He fitted the portable transmitter receiver into his car as an experiment, and was successful in maintaining communication with headquarters while patrolling the streets over an area of approximately one and a half miles.

B.S.I. Chairman

AT the general council meeting of the British Standards Institution, Sir Frank Heath, G.B.E., K.C.B., resigned the chairmanship, in accordance with the by-laws of the Institution. Sir Percy Ashley, K.B.E., C.B., was elected chairman for the ensuing year. He will take over his duties to-day at the annual general meeting.

Logic from the Empire

THE Empire stations have recently cut down the number of frequency announcements, in response to letters from listeners. Apparently those listeners who hear the announcements already know the frequency, and those who fail to hear them are not helped anyway. The fierce logic of this argument has prevailed at Portland Place.



At the general meeting of Scophony Television, Sir Maurice Bonham-Carter, Chairman of the Company, stated that Mr. S. Sagall, Managing Director, was about to pay another visit to the U.S. in order to follow up the interests of the Company contacts already established. The picture shows Mr. Oscar Deutsch pointing out parts of a Scophony big-screen television receiver to Sir Maurice (left) and Mr. Sagall (right).

Noise in Television Receivers

SOME UNSUSPECTED CAUSES OF INTERFERENCE

By S. WEST

THE ultimate limit of sensitivity in television receivers, which are operating under favourable conditions as regards the interference level present at the aerial terminals, is restricted by the inherent noise voltage developed in the receiving equipment.

According to the more or less well-proved findings of various investigators, the noise developed in a normal sound receiver, operating at comparatively high frequencies, is mainly due to the "shot" noise of the first valve. However, in the case of a television receiver, where the stage gain is low and the pass-band is extremely broad, noise due to the second valve in the receiving chain also has some effect. Particularly is this the case when only a single stage of RF amplification is employed; that is to say, when the second valve is the mixer.

In an article entitled "The Signal-Noise Ratio and Superheterodyne Interference Problems,"¹ Cocking shows that a pre-mixer stage gain of at least fourteen times is required if the signal-noise ratio is to compare with that of a TRF receiver. He also pointed out that a gain of fourteen times is not readily achieved with a single stage, and this is probably still true despite the introduction of new valves.

It is thus apparent that it is desirable, when designing highly sensitive vision equipment, to legislate for two RF stages. Various difficulties arise if a greater number of efficient stages are incorporated. These difficulties are mainly the avoidance of feed-back and the prevention of overloading of the mixer stage, which can occur under certain reception conditions and will cause the production of the characteristic "cross-talk" screen patterns.

The amount of noise that can be tolerated is largely bound up with the viewing distance in relation to the screen area and the nature of the programme.

The magnitude of the noise voltage due to the early stages is readily computed approximately by employing conventional formulæ. It should be noted that the band-width figure, required in this calculation, is secured from the overall receiver response characteristic.

The High-voltage Unit

The writer has never been able to reconcile the results of such computations with the true conditions obtaining in practice, however, for the noise has always been considerably in excess of that indicated theoretically. Accordingly, the matter was investigated, and from these investigations the following deductions were made.

It was first noticed that additional noise



occurred in the receiver upon switching on the high-voltage supply and the time-base, and it was thought possible that harmonics of the time-base oscillator were reaching the signal-frequency stages. It was found that this could happen, despite the order of harmonic involved, but was easily prevented by a suitable disposition of the units and slight screening thereof. Attention was, therefore, directed to the high-voltage unit, and it was found that this section was responsible for quite a

BACKGROUND noise is quite as troublesome in television as in sound reception, and in this article the author points out that the noise obtained is often greater than one would expect. He shows that this is to be accounted for by certain stray couplings and indicates how it may be remedied.

large amount of additional noise and that fairly elaborate precautions were required to remove it.

The noise emanating from this unit is due to the high potential involved and takes the form of light brush discharges from the wiring of, and the items comprising, the unit. It is a very difficult matter completely to eradicate these leakages, mainly because they are so slight as to be unnoticeable, even in a well-darkened room. An electrostatic screen, completely enclosing the EHT unit, is desirable, and it should be efficiently earthed with a short length of heavy gauge, insulated wire. The efficiency of this earth lead is of paramount importance, for, in the case of a poor earth connection, the radiation of interference will be increased rather than reduced by the screen.

The internal wiring of the unit is pre-

ferably carried out in bare, heavy gauge, tinned wire, extreme care being taken to ensure an absence of sharp bends and proximity to any of the associated components or even to well-insulated objects.

It is essential to ensure that the EHT unit is kept free from the slightest trace of moisture, and this applies particularly to "stand-off" insulators such as are fitted to the high-voltage condenser and transformer terminals. When it is not possible to arrange for the complete impregnation of the apparatus in a damp occluding substance, it is often desirable to arrange some form of drying apparatus. Successful results can be had from a 60-W lamp, the heat from which is directed to the EHT unit by means of a suitable reflector. Naturally, such elaborations are not required in reasonable humidities, but the amount of moisture present in almost all rooms is surprisingly high. The screening referred to earlier will largely prevent an accumulation of dust, but it is desirable to clean at frequent intervals the various components comprising the unit. All HV apparatus shows a remarkable affinity for dust collection.

Probably the simplest way in which to check for the presence of such noise is by means of a pair of headphones, the time-base and the EHT unit being switched on while listening for any increase in the background noise. The receiver is, of course, operated at maximum sensitivity with no aerial signal.

The VF Stage

Despite the fact that these precautions entirely preclude the possibility of noise due to the EHT and time-base units, there is another somewhat unusual effect which results in the inherent receiver noise being higher than indicated by computation. Possibly this effect has already been observed, but it has been considered that the conditions necessary for its production are not ordinarily encountered. However this may be, it is not without interest.

The writer's attention was first directed to the effect by a user of a sensitive television receiver who stated that the television equipment caused interference on a normal broadcast receiver. It is necessary to point out at this juncture that a high noise level exists, and is tolerated when operating receiving gear at large distances from the transmitter for the simple reason that there is no choice in the matter. The effect to be described is entirely attributable to this high noise level, although a consideration of the following will indicate the possibility of a similar result being due to the picture modulation.

The interference, it was stated, appeared to be at its worst on long waves,

¹ The Wireless World, April 16th, 1937.

Noise in Television Receivers— and progressively fell off toward the high-frequency bands. It was identical in character to normal "shot" noise, but with the exception that car ignition interference, when this had appreciable intensity, could also be heard in the broadcast receiver.

An examination of this information immediately points to the VF stage as being responsible, for the interference band is that covered by the VF amplifier, i.e., 50 c/s to some 2.5 Mc/s (120 metres).

Upon removing the connection to the CR tube grid, this interference is enormously attenuated. The VF stage is a reasonably efficient amplifier of radio-frequencies, and they are radiated by the extension of its anode lead.

A sensitive receiver was set up and the radiation measured over a wide frequency range. The signal level from the lower frequency value, which for the purpose of this test was arbitrarily fixed at 150 kc/s (2,000 metres) up to some 5.0 Mc/s (60 metres) was maintained at a high intensity and with a modulation feed connection of 12in. to the CR tube caused interference in receivers of normal sensitivity situated up to 20-30 yards away.

The interference radiation attenuated rapidly at higher frequencies but increased again in intensity while passing through the IF amplifier pass-band. In this case the interference was radiated by the wiring of the IF amplifier.

At 45 Mc/s the noise developed in a receiver of high sensitivity which is placed in proximity to the original receiver increased materially the original inherent noise level. By removing the VF valve of the vision receiver the noise level, as measured at the detector valve, was reduced, so that it is apparent there was some feed-back of noise at 45 Mc/s.

It is considered that this feed-back effect may account for the production on the screen of interference patterns that cannot be explained by the usual forms of IF harmonic feed-back. Probably the nature of the sync pulses permits the production of these spurious patterns.

Obviously, this state of affairs cannot be permitted to exist, for, apart from the increase in the noise level, there is the social

obligation of ensuring that undesired interference does not mar, for the ordinary listener, an enjoyment of the programmes. By reducing the length of the CR tube grid lead to a minimum, the radiation of interference is greatly reduced, but there is a better plan. In an article "Television Output Circuits,"² Cocking describes an arrangement of a VF amplifier and sync separator wherein the CR tube is connected to a cathode-follower valve. This

² *The Wireless World*, February 23rd, 1939.

Test Report

PHILCO P429

Superheterodyne Portable Operated Throughout by Dry Batteries

THIS is the first of a new type of portable receiver to find its way into the British market. As the result of the introduction of 1.4 volt valves of low filament consumption it has been found practicable to run the LT as well as the HT circuits from lightweight dry batteries. Thus the weight and inconvenience of charging a lead accumulator are obviated to say nothing of the troubles sometimes caused by creeping of the acid.

The capacity of the HT and LT batteries are so proportioned that they both run down approximately at the same time. Under normal conditions a life of 150 to 200 hours is to be expected.

A four-valve superheterodyne circuit with AVC has been adopted, yet the total weight of the set is only 15½lb.

Circuit.—Separate frame aerials are used for medium and long waves and a third winding is provided for coupling an external aerial and earth in the unlikely event of this proving necessary.

The frequency-changer is a heptode and this is followed by a pentode IF amplifier. The second detector stage makes use of a diode-triode valve, the single diode being arranged to provide both signal and AVC rectification. Control bias is applied to both the frequency-changer

arrangement allows appreciable capacity to exist for the CR tube connection without any deleterious effect on the picture definition, so that this lead can be screened, and the radiation of interference entirely prevented.

If in addition careful screening of the VF and RF amplifiers is adopted, the inherent noise level of the receiver is appreciably reduced, and it is possible to employ a much higher overall sensitivity while still retaining a reasonably clean picture background.

and IF amplifier. The triode section is coupled to the output pentode by the conventional resistance capacity circuit.

Negative bias for the output valve is derived from a resistance in the HT return lead; a small negative bias is also applied to the suppressor grid of the IF valve. The AVC is non-delayed.

WAVERANGES	
Medium	200—540 metres
Long	950—1,950 metres

An electrolytic condenser is connected across the HT battery and for this reason contacts on the on-off switch are included to break the HT as well as the LT circuit.

Performance.—Any fears that the reduction in filament consumption might have an adverse effect on efficiency were quickly dispelled when the receiver was first switched on. In fact, the liveliness of the performance is its outstanding characteristic.

Curiously enough long wave sensitivity, usually low in a portable where the dimensions of the frame are so small compared with the wavelength, is if anything better in the Philco set than that on medium waves. We are speaking comparatively, for even on medium waves the set puts to shame the majority of portables employing a heavy accumulator and standard valves. Full sensitivity was necessary only for Radio Normandie; for most other stations on both medium and long waves the loud speaker gave its maximum with the volume control in approximately the mid-position.

The 4½in. permanent-magnet loud speaker makes

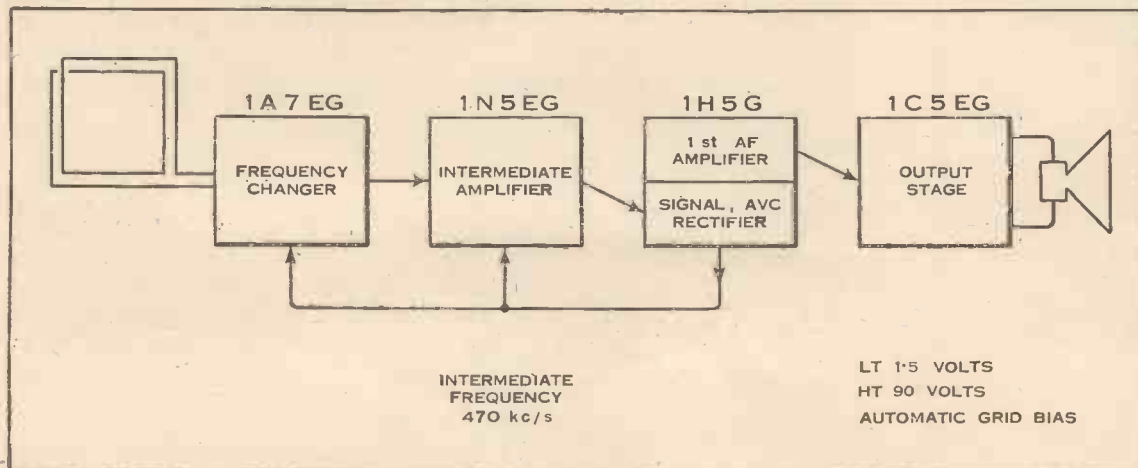

The circuit has most of the features found in standard table-model superheterodynes.

Test Report—Philco P429

good use of the undistorted output of 200 milliwatts from the last valve and the volume is ample for outdoor as well as indoor listening. Due to the enclosed back there is quite a fair bass response, but as the interior is well filled by batteries, etc., there is no pronounced cavity resonance.

The inclusion of AVC has distinct advantages and we found less difference than usual between the performance out of doors and inside a steel-framed building where screening effects are known to be bad. Another effect of AVC is to sharpen the minimum resulting from the directional properties of the frame and

and the top of the cabinet, so that it would probably pay to remove the chassis if at any time a valve should need replacement.

The HT battery is divided into two 45-volt sections and the various inter-connections are made with non-reversible three-pin plugs and sockets. A similar method of connection, with larger pins of dissimilar size, has been adopted for the 1½-volt LT battery. Replacements are now available from the leading battery makers and cost 3s. 6d. for the LT and 4s. 6d. each for the 45-volt HT units.

One stands to lose more than the price of recharging an accumulator if the set should inadvertently be left switched on

Five-metre DX

RECEPTION OF DUTCH AND BELGIAN STATIONS

CONDITIONS remained favourable for long-distance communication on five metres throughout the first week in June, and G6CW has been heard fairly consistently since reporting reception of his signals in London last week.

We are informed by G5TX, of Newport, Isle of Wight, that at 11.15 p.m. on June 8th R5 signals were received from PAOPN, located in Middleburgh, Holland, and also from ON4DJ in Knocke, Belgium.

During this week G6OT, located in North London, was heard working with

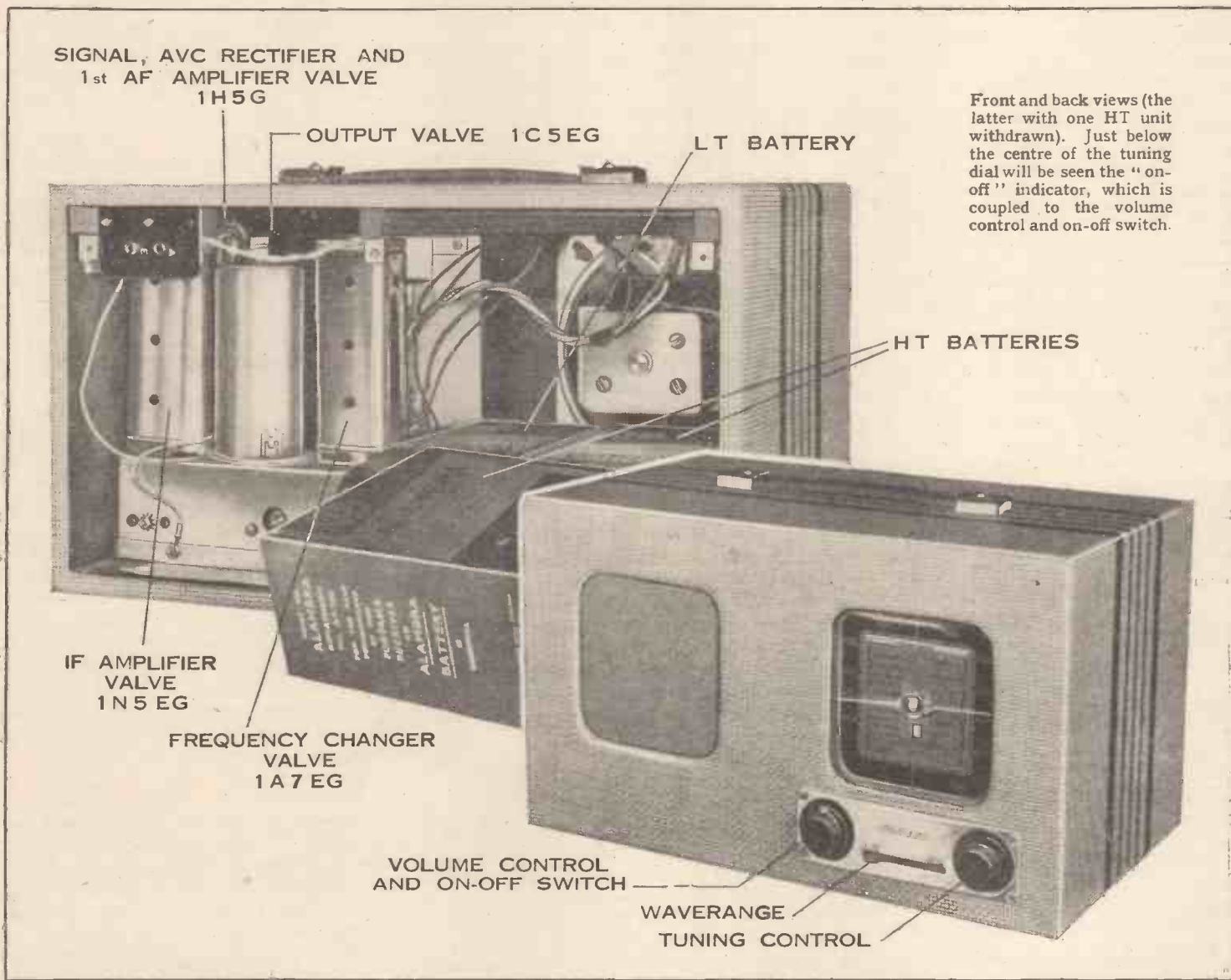

Front and back views (the latter with one HT unit withdrawn). Just below the centre of the tuning dial will be seen the "on-off" indicator, which is coupled to the volume control and on-off switch.

there is little doubt that the set would give good results for approximate direction-finding work on a yacht.

There are a few whistles on the long-wave range, but these are not of the aggressive variety. The only other possible criticism is that the sensitivity appears to fall off slightly at the extreme ends of the medium-wave range.

Constructional Details.—The circuit has been skilfully compressed into a chassis approximately 5in. square. The valves are mounted vertically and there is not very much clearance between the screens

and the designers have for this reason incorporated a "tell-tale" coupled to the volume control and on-off switch showing a square of red on the tuning dial when the set is in use.

Summary.—The lively performance of this neat and handy portable (the dimensions are approximately 13½in. x 8in. x 8in.) is a tribute to the efficiency of the new range of battery valves and to the intelligent use which has been made of their possibilities. There can be little doubt that this set marks a step forward in the evolution of the portable receiver.

G6DH in Clacton, and also with G6CW, while several other London amateurs were heard calling stations on the south-east coast, indication that the signals from east and west as well as from the north and the south were also covering unusually long distances on five metres.

SLADE RADIO CLUB

A NEW hon. secretary has been appointed to this club, his name and address being Mr. L. A. Griffiths, 47, Welwyndale Road, Erdington, Birmingham, 24. Details of the proposed summer activities of the club will soon be available.

Professional Status for the Radio Engineer

ACTIVITIES OF THE INSTITUTE OF WIRELESS TECHNOLOGY

AT some time or another every radio engineer employed professionally gives thought to the question of securing a diploma or other indication of his status which will be recognised by others in the industry. No suggestion of snobbery attaches to the desire for an indication of standing in one's profession; on the contrary, membership of a professional institution should be regarded as a duty of all qualified engineers, for it is now generally accepted that the backbone of any profession is a sound and properly conducted professional institution.

In this connection the claims of the Institute of Wireless Technology must be considered. Founded in 1925, it is claimed to be the only professional body in this country devoted exclusively to wireless engineers.

In 1932 the Institute was incorporated, and therefore confers on members the right to the description "Incorporated Wireless Engineers." Membership is open to all bona fide engineers connected with radio and allied activities, including those engaged in broadcasting, manufacture, research, sound engineering, wireless aeronautics, electronics, television, and kindred branches of the art.

Among the several objects of the Institute, the following are of interest and importance:

"To create and maintain the status of the profession of persons engaged in wireless technology and to set up a high standard of scientific and practical efficiency in relation thereto, and to secure the maintenance of the efficiency, integrity and usefulness of persons practising the same.

"To exercise professional supervision over the members of the Institute and to secure for them such definite professional standing as may assist them in the discharge of their duties."

There are several grades of membership, with the following qualifications:

MEMBERS, who must be at least 30 years of age and have been engaged in the profession for not less than seven years, five of which must be in a position of superior responsibility.

ASSOCIATE MEMBERS, who must be at least 25 years of age and have been engaged in the profession not less than five years, three of which must be in a position of responsibility. They must pass the Institute examinations, or in certain cases submit a thesis or paper that is approved by the Council.

ASSOCIATES, who must be at least 21 years of age and have been engaged in

the profession for at least three years. They must have passed the Institute examinations, or, in certain cases, have submitted a thesis or paper which has been approved by the Council.

GRADUATES, who must be at least 18 years of age, be receiving or have received regular training to fit them for employment in the profession, or be employed in a recognised branch of wireless engineering, or be teachers of wireless subjects, or undergoing a course of training to fit them for this branch of the profession, and have passed the Institute examinations.

IN order to answer the many enquiries which "The Wireless World" is continually receiving regarding the objects of the Institute of Wireless Technology and the nature of the qualification which is required of those who wish to obtain membership, we have invited a member of the Council of the Institute to contribute this article.

STUDENTS, who must be at least 16 years of age and must satisfy the Council as to their general education, and be studying for the profession and/or working under the direction of a Corporate Member of the Institute.

In general, as will be seen, all candidates for admission to the Institute in any grade other than that of Student must satisfy the Council as to their knowledge of the fundamental principles of radio engineering, and to ensure this, two examinations are held twice yearly, the Preliminary Examination in educational subjects, and the Graduateship Examination in technical (professional) subjects. In the case of candidates who hold a recognised educational certificate certain exemptions may be given in respect of the Preliminary Examination. The Graduateship Examination must be taken by all candidates.

The subjects of the examinations are as follows:

PRELIMINARY.—English. Mathematics and Mechanics. Electricity and Magnetism. Heat, Light and Sound, or Inorganic Chemistry.

GRADUATESHIP.—Electrical Technology (one three-hour paper). Wireless Technology (two three-hour papers).

Measurements (one three-hour paper).

The examination syllabuses are revised at regular intervals in order that they may conform with modern accepted practice. Here are specimen questions from the November, 1938, papers:

WIRELESS TECHNOLOGY.—What are the advantages of incorporating inverse feedback in the audio-frequency stages of a receiver? Draw a circuit diagram of the output stage of an amplifier, giving suitable values, and show how 5 per cent. feedback may be obtained.

A form of electrical interference encountered in radio work is known as "conducted interference." Explain the nature of this interference and suggest methods of eliminating it.

What is meant by modulation? Describe in detail a method of modulating a valve transmitter. How can the percentage modulation of the transmitter be measured?

Explain in detail how exact synchronisation is obtained between a television transmitter and receiver.

MEASUREMENTS.—Describe a resonance method of measuring (a) the effective resistance; (b) the self-capacity of a tuning coil at a frequency of the order of 1,000 kc/s. What corrections have to be made, and precautions taken, to improve the accuracy of the final results?

Give a circuit diagram of a valve oscillator to be used for laboratory measurements at frequencies in the region of 20 Mc/s. Specify as completely as possible the chief components used in the circuits. Describe one method of calibrating the oscillator.

How would you proceed to determine experimentally the impedance, to a very small AC, of a LF choke while carrying a direct current of, say, 50 mA? Assume the inductance of the choke to be of the order of 20 henries, and its resistance about 200 ohms. Test frequency 50 cycles/sec.

The Institute numbers amongst its members workers in every field of wireless endeavour, and members are to be found in all parts of the world. The services, too, are well represented, particularly the wireless section of the Royal Air Force, and student membership is open to those in the Royal Navy, Royal Air Force and Royal Corps of Signals who wish to take the Institute examinations. The examinations are of particular value to those leaving the service for civil life as the qualification conferred thereby will be of material help when seeking employment.

Professional Status for the Radio Engineer—

No person is refused admission to the Institute providing he can satisfy the Council that he is eligible for admission both in respect of his theoretical knowledge and his practical ability, but no person is admitted until he has proved his worth and has shown that his admission will be beneficial both to himself and to the Institute.

There are certain definite material benefits to be derived from membership, such as the meetings at which lectures are given and papers read on various phases of wireless engineering, a well-stocked, up-to-date library, which is available to all members and students, the employment register conducted by the Institute which has proved of value to many members, and a mutual aid fund which has been established for some years and from which it has been possible to help members in a

practical manner in times of stress. The officers of the Institute, including the Secretary, all work in an honorary capacity, and their advice and assistance is available without stint to all members desiring it.

The membership of the Institute, which has gradually but steadily grown during the past fourteen years, has been achieved not by admitting all who applied, but by careful selection and admission only of those likely to do credit alike to the profession and the Institute. It is on these lines that all recognised professional institutions have grown—not rapidly, but, by virtue of their selective principles, slowly and surely.

Anyone interested in securing further information concerning the Institute of Wireless Technology may do so by writing to the Secretary, at 4, Vernon Place, Southampton Row, London, W.C.1.

begin to complain that their reception isn't what it was and to wonder why. I haven't suffered because I took jolly good care when I put in my earth-plate to see that the hole made for it was deep enough to ensure its being well down into the underlying clay, where a good contact is a certainty at all times and seasons. But, as is the case in some places, you have to delve pretty deeply to bring about this desirable state of affairs. We have a top layer of light gravelly soil, and just below it a sub-soil that looks good enough for a sound earth connection, but actually isn't in dry weather, as I've proved by experiment. Lots of people are deceived by the appearance of this soil and dig no further. Reception is good enough so long as there is a normal amount of rain, but there can be a very marked falling off towards the end of a rainless spell. If your results have been poor during the drought, make sure that you haven't the same deceptive kind of upper subsoil.



Instruction Needed

TALKING the other day to an eminent designer of receiving sets, I asked: "On what kind of aerial efficiency do you base your calculations when you're evolving your circuits?" He answered, as I rather expected he would, that that problem was the set designer's nightmare. Aerials may range from the highly efficient to the utterly bad, and those who buy the set expect it to give a good account of itself with whatever kind they happen to possess. I've long thought that set manufacturers don't say half enough about aerials in the books of the words that accompany their sets. Some of them, if they mention the subject at all, just say "use a good aerial, the higher within reason the better," and leave it at that. The ideal method would be to sell the aerial as an integral part of the receiving equipment with the set; but that wouldn't work, for obvious reasons. There's no reason, though, why the handbook should not contain drawings—with dimensions—of aerials recommended in order to enable the set to be at its best on all the wavebands covered. Were such instructions issued with every receiver they would serve to inspire purchasers, and we should

Random Radiations

By "DIALLIST"

Semi-scrambled

THE other Saturday evening Mr. Raymond Gram Swing's weekly talk was coming over so well, though I hadn't been finding short-wave conditions too good myself, that I thought I'd try to see what kind of channel was being used. It didn't take long to light upon it amongst the rather high-frequency channels, but I was surprised to discover that it was being transmitted in semi-scrambled form. It wasn't the complete scrambling that you hear on the transatlantic and other long-distance wireless telephone services, which makes voices all squeaky and words entirely unintelligible. Mr. Swing's well-known voice was easily recognisable, and sufficient of the words could be understood to leave no doubt that one was listening to his talk; but the transmission had certainly been scrambled to some extent. I wonder why that's done with a talk that is being broadcast? Is it to prevent unauthorised relaying? Or do the G.P.O. engineers find that they can obtain better quality by making some use of the scrambler at one end and the de-scrambler at the other? Is this possibly one of the secrets of that wonderful absence of background noises on which I've commented before?

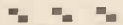

Start Point

BY the time that you read this the B.B.C.'s new transmitter at Start Point will be in action, and if you live on the South Coast or in the West Country you are probably blessing it already. As I know from experience, reception of the home stations in the southerly parts of Devon, Dorset and Cornwall has hitherto been none too good; the new station should make a great difference with its initial 100 kilowatts; and things will doubtless be still better when it goes up to 150 with the coming into force of the Montréux Plan next spring. What I found during visits to

those three counties was that though you could pick up the home programmes right enough, you had to use the set in such a sensitive condition to bring them up to good volume that every interfering noise, man-made or natural, was brought out to the full. The high-power transmissions from Start Point will provide a far better signal-to-noise ratio, to the comfort of all concerned.



Earths Can be Deceivers

AS I write we're enjoying the twenty-second day of a completely rainless period in my part of the world, nor do there seem to be any signs that the end of the drought is in sight. It won't be long, I think, before a good many folk hereabouts

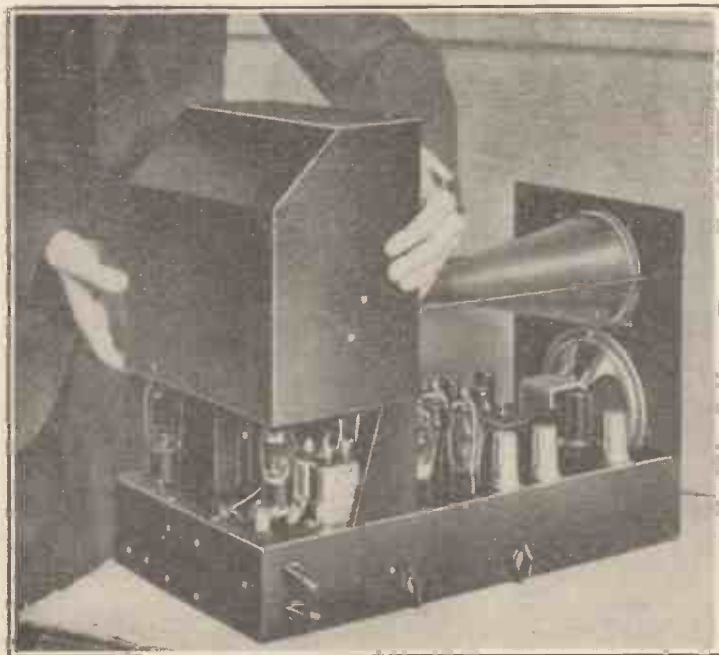

AMERICAN TELEVISION KIT. Multi-channel reception, the need for which has not so far arisen in this country, has been catered for in this Meissner television receiver by the provision of two pre-tuned channels with switch selection. Blank switch contacts are fitted to allow two extra channels to be added. The vision amplifier of the set, which is supplied in parts for home assembly, employs two IF stages; electrostatic deflection is used for the CR tube.

begin to see a diminution in the numbers of those ghastly contraptions which still disfigure so many houses and gardens.

Place-names Again

BEFORE now I've commented on the differences between one announcer and another in the matter of pronouncing foreign proper names, particularly place-names. During the last few weeks, when Turkey has been a good deal in the news, Angora has provided a case in point. Some of them have called it Angora; others Ankara, making the second a long; others again Ankūra, with the second a short. All this is very confusing to the listener, who might well imagine that the three varieties were the names of three different places. The town has an old and accepted English name: we don't talk about an Ankara rabbit, with either a long or a short second a! Where there are English names they should be used. To me it seems just nonsense to talk about Rome, Naples, Munich, Cöpenhagen, Cologne, and Moscow at one moment and at the next to turn Gothenberg into Göteborg, Marseilles into Marseille, and Nuremberg into Nürnberg. If announcers want to scrap good old English names they should be consistent and give us such things as Wien, Firenze, Milano, Bruxelles, and Alger.

Adrift

WHILST trying out a new receiver of the "all-wave" type the other day, I picked up the tuning note of the 21.47 Mc/s GSH at 11.38 a.m. This set has an auxiliary pointer, which travels about eight times as fast as the main indicator round a dial marked from 0 to 100. At 11.38 the reading on the main dial was 21 Mc/s and that on the auxiliary 11. By 11.40 the auxiliary pointer had had to be moved to 9½ to hold the signal. At that moment the tuning note was switched off in the studio for a minute. When it came on again at 11.41 it could only just be heard and the pointer had to be moved to 8½. The transmission opened at 11.42. The volume control was then turned right down and the set left for just five minutes. The reading on the auxiliary dial, when resonance had been obtained by a further small adjustment, was now slightly under 8. I don't know how much further the oscillator would have drifted if given a chance, for I was too exasperated to continue the experiment. Some time, when I have an odd hour to fill in, I'll try.

A Futile Business

What I want to know is how does one calibrate a receiver of this kind? Don't write and tell me to give it a good warm up first of all; the set had been in use on one waveband or another for a good half-hour before I picked up GSH; one really can't switch on and "cook" the valves ages beforehand every time one wants to use the set. And from the way in which it behaved, I don't think that any reasonable amount of warming up would have made much difference. It seems to me a rather futile business to provide fine tuning and a large auxiliary dial if oscillator drift makes the reading obtained often quite useless for future reference. It may not matter very much if the recorded reading for a strongly received station such as GSH proves to be a little out when you turn to it at a future time; you can always find a signal of that kind.

But it does matter very much indeed in the case of "difficult" stations if the readings, laboriously obtained and carefully logged, mean nothing.

A New Game

SOME youngsters in my part of the world, who are ardent wireless enthusiasts, have invented a new open-air game. It consists in collecting as many motor car registration letters and numbers as possible which make wireless terms or the call-signs of stations. Until they inveigled me into playing I'd no idea how common these were. Almost the first car I saw was a DJN and

the letters of a good many other well-known call signs were soon collected. Then HT had come along and GB is, of course, too common to be worth counting. ATI and ATC bring back memories of early wireless days. I'm still hoping for LTB and AVC, though AFC and AGC have been reported by the band. The greatest prizes of all are the registration plates, which make call-signs complete with letters and numbers. We are searching ardently for combinations such as TPA3, JLT2, VUD3, FZE8, LSY3 and so on. It's a fascinating game. Try it! At times the excitement quite equals that of the now almost forgotten game of "Beaver."

Letters to the Editor

Frequency Modulation

THE statement in a letter in *The Wireless World* of May 25th, that frequency and phase modulation are the same thing, is indicative of a not uncommon misconception concerning the varieties of modulation. Readers might be interested in the very neat definition given by J. E. Young in Part V, "Electric Communication and Electronics." It is as follows:—

A single frequency current wave can be expressed as

$$i = A \sin (2\pi ft + \theta)$$

where A is the amplitude, f is the frequency (when constant) and θ the relative phase. If any of the three independent magnitudes A, f or θ , is slowly varied (slow in comparison to f) the wave is said to be modulated. The three cases are called amplitude, frequency and phase modulation, respectively.

Catterick.

Guaranteed Servicing

YOUR editorial in *The Wireless World* of June 1st, dealing with guaranteed radio servicing, is well timed. Although there is no general scheme of this description it should be made clear that both Messrs. Mul-lard and Philco have launched and encouraged such schemes; unfortunately their example has not been followed by makers as a whole. Certain service dealers operate on similar lines, and particulars of the writer's methods, together with specimen guarantee cards and seals, are enclosed.

The public has been imposed upon so long that it has grown wary of the unscrupulous methods of the bulk of the dealers, and as long as manufacturers continue to appoint "Service" dealers on the basis of the amount of business obtainable, the reputation of the trade and genuine servicemen will suffer.

Some of the big multiple stores are among the worst offenders; if they employ servicemen these are so underpaid and so poorly equipped (often there is no equipment at all) that to do good work is a sheer impossibility. Others in the big dealer class put out their servicing and coolly suggest a flat rate of 3s. 6d. per receiver, valves extra.

Again, it is not generally known that the three months makers' guarantee is due to pressure on the part of the trade, and no genuine dealer who knows anything about the "innards" of a wireless set would bother about the length of the guarantee period if he knew that there was a fixed charge he could make in the event of breakdowns after the expiration of the guarantee.

The Editor does not necessarily endorse the opinions of his correspondents

What must be remembered is this: in no profession is a higher degree of patience and intelligence required than in radio servicing. It is a profession without parallel and deserves an adequate system of fees to be set up and backed by the manufacturers.

Think of the size of the service shops of the big motor car distributors and then look for the service room in the average radio dealer and the necessity for guaranteed service in radio is emphasised and the need for "weeding out" suggested in your editorial is overdue.

Carry on, *Wireless World*, make things better for the genuine service engineer and you will have at least one grateful reader.

J. PARKINSON, Junr.,
Old Oak Radio Service.

Whitchurch, Cardiff.

AS the managing director of a firm specialising in service, and more particularly as secretary of an association of such firms, I was very interested by your editorial in *The Wireless World* of June 1st.

The scheme inaugurated by our Danish colleagues is similar to one we have had in mind for some time, but which we have been forced by circumstances to hold in abeyance. It would appear that conditions in Denmark are somewhat different from those prevailing in this country, proving once again that the "foreigner" is much longer sighted, in the radio industry at least, than his British counterpart.

It is a fact that over 50,000 sets are serviced annually by members of my association and, as no member of this body is allowed to deal direct with the public, it will be obvious that 50,000 sets which go into the radio dealers' premises find their way to the service specialist. Actually, there are quite a number of trade service firms outside the association, and it is probably safe to assume that a total of something like 80,000 or 100,000 sets pass through the specialists' hands every year.

The difficulty in instituting a scheme for the safeguarding of the public lies in the regrettable fact that the majority of radio retailers are strongly averse from disclosing that their repair work is done by a specialist firm instead of by themselves. It would be thought that the reverse would be the case; rather would one imagine that the retailer

would realise that he had a valuable asset and one worth publicising by virtue of the backing that an independent service organisation can provide, with its resources in skilled personnel, equipment and experience.

As matters stand at present, members of the National Radio Trade Service Association give to their trade customers a definite three months' guarantee on the work and material specified on each invoice; this has the desired effect of giving the retailer confidence in the service firm, and in due course the public gain confidence in the retailer who has that guarantee behind him, even though the public is unaware of the actual circumstances.

It is impossible to avoid a certain proportion of "returns," but the percentage is very low, and obviously every effort is made to keep the percentage as low as possible; the service firm suffering a high percentage of "returns" would soon be bankrupt.

I hope I have said sufficient to make it clear that, whilst trade politics at present prohibit the adoption of a scheme along similar lines to the Danish idea, the reputable service firms in this country do all they can to safeguard the interests of the listener. Conditions in the radio trade are slowly changing, and in due course the service specialists may be able to take an openly acknowledged place in the radio industry, to the ultimate benefit of all concerned, a state of affairs which the present short-sighted policies of manufacturers and retailers precludes.

H. C. RYLATT,

Hon. Sec., National Radio Trade Service Association.
Lincoln.

Television Programmes

Sound 41.5 Mc/s.

Vision 45 Mc/s.

An hour's special film transmission intended for demonstration purposes will be given from 11 a.m. to 12 noon each weekday. The National or Regional programme will be radiated on 41.5 Mc/s from approximately 7.45 to 9 p.m. daily.

THURSDAY, JUNE 15th.

3, "Rococo," a comedy by Granville Barker. 3.20, Cartoon Film. 3.25, "Passion, Poison, and Petrification" or "The Fatal Gazogene," by Bernard Shaw. 3.50-4.15, 251st edition of Picture Page.

9, Alfredo and his Gypsy Orchestra. 9.30, Cartoon Film. 9.35, Gaumont-British News. 9.45-10.30, 252nd edition of Picture Page.

FRIDAY, JUNE 16th.

3, Western Film—"The Fighting Texan." 9, "Footwork," a survey of the season's new ballroom steps. 9.20, British Movietonews. 9.30, "Sunday in the Country," No. 3. 9.45, Cartoon Film. 9.50, Puppet Parade, introducing The Ebor Marionettes and the Hogarth Puppets. 10.5, Film. 10.15-10.25, Maria Antonia de Castro, pianoforte.

SATURDAY, JUNE 17th.

3, Cartoon Film. 3.5, Western Cabaret, No. 3, with Big Bill Campbell and Evelyn Dall. 3.50, British Movietonews.

9, Gaumont-British News. 9.10-10.40, "Ah, Wilderness," a comedy by Eugene O'Neill. Cast includes Kitty de Legh, Percy Parsons and Joan Miller. The action takes place in a small town in Connecticut in 1906.

SUNDAY, JUNE 18th.

3, The Hogarth Puppets with the B.B.C.

Television Orchestra. 3.15, Cartoon Film. 3.20, "Contrasts," with songs by Kay Kimber and La Marques in Spanish Dances. 3.35-4.5, "Five Faces"—Film.

8.50, News. 9.5-10.30, "Inquest," a play by Michael Barrington, based on Campbell Gullan's recent production at the Duke of York's Theatre.

MONDAY, JUNE 19th.

3-4.30, A. Bromley Davenport and Victoria Hopper in "Magic," a fantastic comedy by G. K. Chesterton.

9, Intimate Cabaret. 9.25, Cartoon Film. 9.30, "Rough Island Story," No. 3, Opening up the Atlantic. 9.55, Gaumont-British News. 10.5-10.45, "Doctor, My Book," a play by Alicia Ramsey and Rudolph de Cordova portraying the inventor of the Abernethy biscuit.

TUESDAY, JUNE 20th.

3-4.30, "Murder on the Second Floor," a play by Frank Vosper. The action takes place in a Bloomsbury Boarding House.

9, O.B. from the stage of the London Coliseum. 10, British Movietonews. 10.10, "This Cruising," illustrated in verse and cartoon by Reginald Arkell and Harry Rutherford. 10.20, Cartoon Film. 10.25-10.35, Esther Fisher, pianoforte.

WEDNESDAY, JUNE 21st.

3, Ronald Frankau in "Cabaret," with Jean Colin and Tollefsen. 3.35, British Movietonews. 3.45, Fashions for the Beach.

9-10.30, Jean Murat and Vera Korène in "Le Deuxième Bureau"—Film.

"Solus" Static Stabilisers

Regulation of HT Supplies

THESE instruments, which are essentially mains transformers of a special type, were developed originally to free X-ray equipment from the effects of mains voltage fluctuation. They contain no valves or mechanical moving parts and should prove of value in many radio applications, particularly in connection with "works" test and laboratory apparatus.

The "Solus" static stabilisers work on the principle of the non-linear impedance of an oscillating circuit, containing a condenser and a saturated iron choke. The resonance circuit LC is in series with the primary of the transformer T across mains voltage e_1 . The voltage e_1 is divided between the primary of T and the resonant circuit, the output voltage e_2 being proportional to the first part. Any variation of the input mains voltage results in variation of the impedance of the resonance circuit on account of the varying inductance of the saturated choke L.

The working part of the resonance curve is carefully selected so as to give exact compensation for the variation of the mains voltage, the difference voltage being taken over by the resonance circuit.

The output transformer receives constant

input voltage, and consequently the output voltage will also be constant. For ± 17 per cent. variation of the input voltage a stabilisation as good as ± 1 per cent. in the output voltage is obtained at a regulation from 0 to full load not exceeding 3 per cent. Constant frequency is required for good performance of the instrument.

Four types are available for 3-, 60-, 120- and 300-watt outputs from a nominal input voltage of 230. Prices range from £4 15s. to £15, and the makers are the Solus Electrical Co., 100, Judd Street, London, W.C.2.

HENRY FARRAD'S SOLUTION

(See page 553)

AS the receiver continues to function for gramophone purposes with any valve withdrawn except the "DD Pen," the latter is obviously a double diode output pentode to which the pick-up is directly connected, probably through a step-up transformer (the power rectifier is evidently of the metal type; or, if a valve, is not counted as such). But the valve itself is O.K.; therefore, the fault must be in the associated circuits. Increased heat must be due to increased current, which could not be caused by a failure in any except the grid-to-cathode circuit. A short-circuited bias resistor or by-pass condenser is a possible cause, and so is an open-circuited grid leak. But inspection of the photo will show that in the lead to the top cap, which in the type of valve mentioned is the grid terminal, there is a bulge; this bulge reveals that the previously common but unwise practice has been followed of inserting a "grid stopper" resistor at this point to quell any tendency to instability. The practice is unwise because the resistor is exposed to a considerable amount of alternate heating and cooling which increases the risk of breakdown. (The large amount of heat from the valve, even normally, was commented on.) The fault appears to have been intermittent until Mr. McThrifty took the valve away for test, in doing which he would have to disturb the connector, and the pull on it appears to have rendered the open-circuit permanent. However, if this diagnosis is correct, the cure is not a matter of great expense; in fact, it would be advisable to try effecting it free of charge by cutting the resistor out entirely and removing the risk at this point. If it is definitely unworkable that way, it ought to be possible to keep the new resistor an inch or two away from the valve.

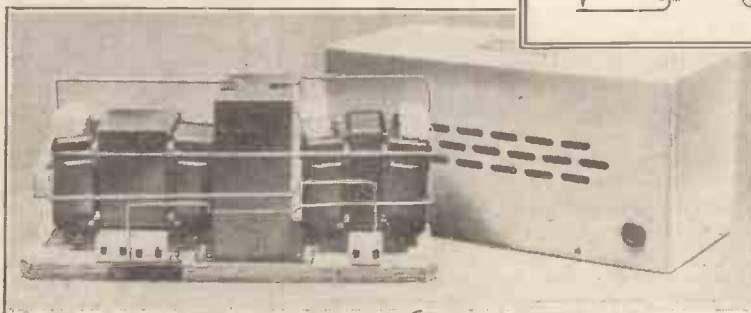
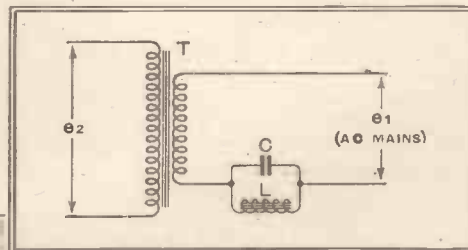

No moving parts or valves are used in the "Solus" voltage stabiliser which utilises the non-linear impedance characteristic of a tuned circuit.

Recent Inventions

PHOTO-ELECTRIC AMPLIFIERS

IT is usual to take the polarising voltage for a PE cell from the same source as that supplying the anode voltage of the associated amplifier valve. Under these conditions the anode voltage on the valve naturally varies with the current passed by the valve, and if the current drops to a low value the resulting rise in voltage may be sufficient to damage the cell.

In order to avoid this risk, while still using a common voltage supply, the anode-cathode circuit of the valve is shunted by two resistances in circuit, and one of these is arranged to be in series with the PE cell and the source of supply.

The arrangement is such that any abnormal rise of voltage occurring in the valve circuit automatically produces a corresponding drop in voltage in the circuit, including the PE cell, thus keeping constant the voltage supplied to the latter.

Electrical Research Products, Inc., and T. Blashill. Application date September 10th, 1937. No. 498865.

DETECTING INVISIBLE AIR-CRAFT

THE presence of a normally invisible aeroplane is detected by the effect of transmitted USW waves reflected from it on to a system of grouped receiving aerials. The cathode-ray tube T is fed with framing impulses from a time base F, and with line impulses from an associated oscillator L. The latter impulses are super-imposed on longer impulses, the combination

Brief descriptions of the more interesting radio devices and improvements issued as patents will be included in this section.

being fed to and radiated by an ultra-short-wave transmitting aerial A.

A number of receiving aerials B are distributed at various points about the area under surveillance, and are coupled at S to the control grid G of the cathode-ray tube. Under normal conditions the receiving aerials B will produce a raster on the screen of the cathode-ray tube showing one vertical black bar, due to the radiated signals. If, however, an aeroplane flies through the radiation field, it will intercept and reflect some of the waves, and these will reach one or other of the aerials B at a slightly different time to the direct wave. The resulting phase difference produces another "bar" image which will change from black to white as the aeroplane moves on its course. By switching the aerials B in circuit, one after the other, the direction of the invisible aeroplane can be ascertained with a fair degree of accuracy.

Marconi's Wireless Telegraph Co., Ltd., and D. L. Plaistowe. Application date, August 13th, 1937. No. 500588.

IMPROVING BASS REPRODUCTION

THE figure shows a form of coupling designed to allow due value to be given to the bass notes in musical reproduction, without, at the same time, producing an unnatural "boominess" in speech. It

is also designed to pass the lower musical frequencies while reducing hum from the mains supply.

The circuit elements marked R, L1, C1, and R2 in the anode circuit of the amplifying valve V, together with the resistance-capacity coupling which is shown feeding to the next valve V1, conform to usual practice. The invention consists in the addi-

coupling which includes a toothed gear. When the incoming signal strength reaches a certain value, say, when the tuning is within 250 cycles of the carrier-wave frequency, a biasing voltage is developed, and releases a detent which engages and stops the rotation of the toothed wheel. This prevents any direct drive, and introduces a reducing train of wheels between the control knob and the shaft of the tuning-condenser.

Electric and Musical Industries, Ltd. (assignees of E. N. Muller). Convention date (Luxemburg), July 1st, 1936. No. 500111.

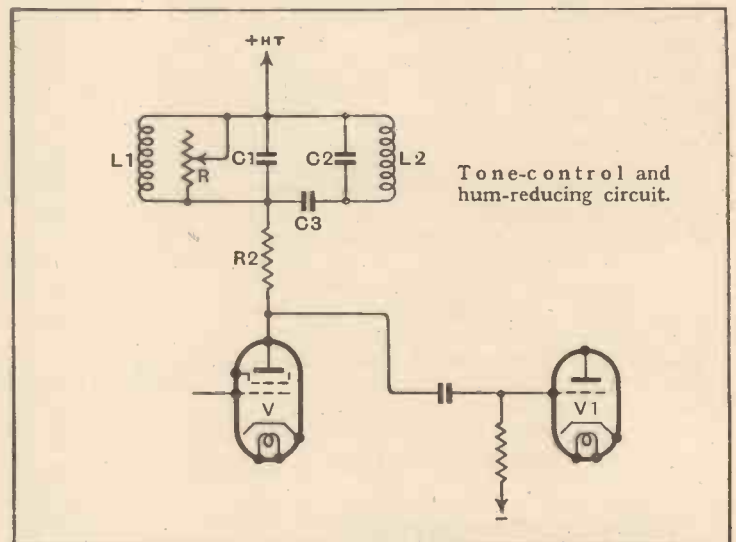

tion of the shunt circuit marked L2, C2 and C3. The values of L2 and C2 are made substantially the same as those of L1 and C1, and the desired tone control is obtained by varying the value of C3. By making the value of C3 equal, say, to that of C1 the response curve is caused to have, *inter alia*, a pronounced drop in the neighbourhood of the usual mains hum frequency. In general, it is possible to select any desired point in the frequency response curve for similar discrimination.

F. J. Chart (assignee of M. G. Clay). Convention date (U.S.A.), November 24th, 1937. No. 500865.

EASY CONTROL OF TUNING

THE correct tuning of a highly selective set calls for a degree of skill and attention that tends to become fatiguing to a listener who wishes to make frequent changes of programme. Careless operation leads to noticeable distortion, and, in general, prevents the set from giving of its best.

According to the invention, the problem is solved by arranging matters so that the listener searches for a desired station on a geared-down tuning control. As the critical tuning point is approached, however, the gear ratio is automatically reduced, so that the exact point is reached by a much slower movement of the indicator needle.

The fast, or normal control, is by direct drive through a friction

BEAM VALVES

THE electrons emitted from the cathode of a valve are modulated by a control grid and separated into two streams which travel in opposite directions around a circular path. At the point where they should meet, they are deflected by a controlling voltage so that they either fall on to an electrode, or through an adjacent aperture on to a second electrode.

The various electrodes are so arranged that the valve may be used as a frequency changer in a superhet. receiver. Its advantage lies in the fact that the incoming signals are caused to influence the electron stream at a point remote from that at which the local oscillations are applied, so that the two signals are mixed to form the intermediate frequency by electron coupling. The arrangement prevents space-charge leakage from the "virtual" cathode to the control grid, and so avoids damping.

N. V. Philips Gloeilampen Fabriek. Convention date (Germany), May 14th, 1937. No. 500090.

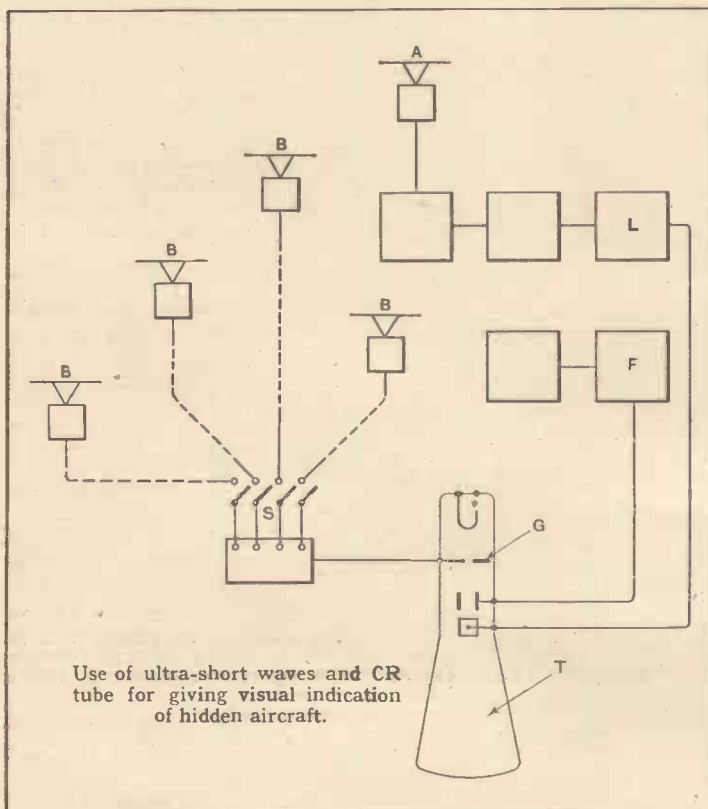

Use of ultra-short waves and CR tube for giving visual indication of hidden aircraft.

The British abstracts published here are prepared with the permission of the Controller of H.M. Stationery Office, from specifications obtainable at the Patent Office, 25, Southampton Buildings, London, W.C.2, price 1/- each.

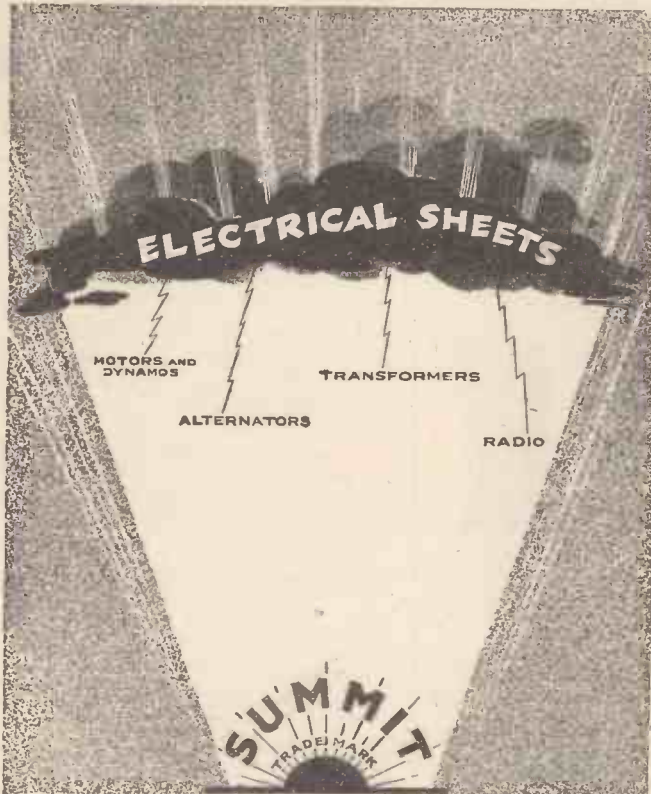

ADDRESS ALL ENQUIRIES TO
JOHN SUMMERS & SONS LTD.
SHOTTON · CHESTER

Established 1851

Telephone :
CONNAH'S QUAY 200

Telegrams :
SUMMERS CHESTER

Second Edition—

RADIO DATA CHARTS

A SERIES OF ABACS
providing most of the essential
Data required in Receiver Design.

By **R. T. BEATTY, M.A., B.E., D.Sc.**

Published from the Offices of
"THE WIRELESS WORLD"

"Radio Data Charts" provide designers of wireless apparatus with a ready and convenient means of solving problems without having recourse to complicated formulæ and mathematics.

By the use of "Radio Data Charts" such abstruse problems as the design of tuning coils are solved almost as easily as the simple application of Ohm's Law.

Price 4/6 net By post 4/10

From leading booksellers or direct from the publishers

ILIFFE & SONS LTD.

Dorset House, Stamford Street, London, S.E.1

W.W.93

B.I. RADIO MATERIALS

We have had a long experience in the manufacture of all kinds of Cables and Wires, Aluminium Sheets and Strips, Static Condensers, Insulators and Iron Work, Telephone Cords and Copper Earthing Rods, for Radio use. Write for Radio Materials catalogue describing these and other B.I. manufactures.



BRITISH INSULATED CABLES LTD.,
CABLE MAKERS AND ELECTRICAL ENGINEERS,
PRESCOT, LANCS. Tel. No. PRESCOT 6571

*Player's
Please*

EVERYONE



MEDIUM OR MILD

BOTH BLENDS ARE
CORK-TIPPED or PLAIN
10 for 6½D 20 for 1/0½D

N.C.C.451E

CLASSIFIED ADVERTISEMENTS

NOTICES

THE CHARGE FOR ADVERTISEMENTS in these columns is

12 words or less, 3/- and 3d. for every additional word.

Each paragraph is charged separately and name and address must be counted.

SERIES DISCOUNTS are allowed to Trade Advertisers as follows on orders for consecutive insertions, provided a contract is placed in advance, and in the absence of fresh instructions the entire "copy" is repeated from the previous issue: 13 consecutive insertions 5%, 26 consecutive, 10%; 52 consecutive, 15%.

ADVERTISEMENTS for these columns are accepted up to **FIRST POST ON MONDAY MORNING** (previous to date of issue) at the Head Offices of "The Wireless World," Dorset House, Stamford Street, London, S.E.1, or on **SATURDAY MORNING** at the Branch Offices, 8-10, Corporation Street, Coventry; Guildhall Buildings, Navigation Street, Birmingham, 2; 260, Deansgate, Manchester, 3; 26a, Renfield Street, Glasgow, C.2.

Advertisements that arrive too late for a particular issue will automatically be inserted in the following issue unless accompanied by instructions to the contrary. All advertisements in this section must be strictly prepaid.

The proprietors retain the right to refuse or withdraw advertisements at their discretion.

Postal Orders and Cheques sent in payment for advertisements should be made **& Co.** payable to **LIFFE & SONS Ltd.**, and crossed **Notes being untraceable** if lost in transit should not be sent as remittances.

All letters relating to advertisements should quote the number which is printed at the end of each advertisement and the date of the issue in which it appeared.

The proprietors are not responsible for clerical or printers' errors, although every care is taken to avoid mistakes.

ARMSTRONG'S NEW HEADQUARTERS



This is where we look forward to welcoming you to hear a demonstration of any or all of the range of Armstrong Chassis. We can say a lot about the quality and lifelike reproduction obtained from our products, but hearing is believing and we always prefer to let the products "speak for themselves." From Mondays to Fridays we are demonstrating until 7.30 p.m. and on Saturdays an Engineer is in attendance until 5.30 p.m. for the convenience of customers who cannot call during the week. In the meantime send for our Illustrated Catalogue which includes the following outstanding models.

MODEL RF96 Price £8.0.0
6-V. ALL-WAVE RADIOGRAM CHASSIS
 Complete with Matched M.C. Speaker.

Incorporating R.F. Amplifier. 3 wavebands, 17.9-50, 200-550, 1,000-2,000 m., 3 stages of A.V.C., corrected 3 1/2 watts output.

MODEL AW93PP . . . Price £10.10.0
9-V. ALL-WAVE RADIOGRAM CHASSIS
 3 wavebands, R.F. Pre-Amplifier, 3 stages of A.V.C. and 8 watts R.C. coupled Triode P.P. output.

MODEL AW125PP . . Price £17.17.0
12-V. ALL-WAVE RADIOGRAM CHASSIS
 5 wavebands, 12-550 continuous, 1,000-2,000 m., R.F. Pre-Amplifier, 2 I.F. stages with Variable Selectivity. Manual R.F. gain control and 10 watts R.C. coupled Triode P.P. output.

ARMSTRONG MANUFACTURING CO.,
WALTERS ROAD, HOLLOWAY, LONDON, N.7
 (Adjoining Holloway Arcade).
 Telephone: NORth 3213.

NUMBERED ADDRESSES

For the convenience of private advertisers, letters may be addressed to numbers at "The Wireless World" Office. When this is desired, the sum of 6d. to defray the cost of registration and to cover postage on replies must be added to the advertisement charge, which must include the words Box 000, c/o "The Wireless World." All replies should be addressed to the Box number shown in the advertisement, c/o "The Wireless World," Dorset House, Stamford Street, London, S.E.1. Readers who reply to Box No. advertisements are warned against sending remittances through the post except in registered envelopes: in all such cases the use of the Deposit System is recommended, and the envelope should be clearly marked "Deposit Department."

DEPOSIT SYSTEM

Readers who hesitate to send money to advertisers in these columns may deal in perfect safety by availing themselves of our Deposit System. If the money be deposited with "The Wireless World," both parties are advised of its receipt.

The time allowed for decision is three days, counting from receipt of goods, after which period, if buyer decides not to retain goods, they must be returned to sender. If a sale is effected, buyer instructs us to remit amount to seller, but if not, seller instructs us to return amount to depositor. Carriage is paid by the buyer, but in the event of no sale, and subject to there being no different arrangement between buyer and seller, each pays carriage one way. The seller takes the risk of loss or damage in transit, for which we take no responsibility. For all transactions up to £10, a deposit fee of 1/- is charged; on transactions over £10 and under £50, the fee is 2/6; over £50, 5/-. All deposit matters are dealt with at Dorset House, Stamford Street, London, S.E.1, and cheques and money orders should be made payable to Liffe & Sons Limited.

SPECIAL NOTE.—Readers who reply to advertisements and receive no answer to their enquiries are requested to regard the silence as an indication that the goods advertised have already been disposed of. Advertisers often receive so many enquiries that it is quite impossible to reply to each one by post. When sending remittances direct to an advertiser, stamp for return should also be included for use in the event of the application proving unsuccessful.

NEW RECEIVERS AND AMPLIFIERS

R. RADIO CLEARANCE, Ltd.,
 63 High Holborn, W.C.1. Phone: Holborn 4631.

GUTHMAN MC Murdo Silver Communication Receiver.

WE are Sole Distributors for the United Kingdom of Above Product.

CIRCUIT Superhet, with double regeneration obtained at signal frequency and also at intermediate frequency. As a result, very high sensitivity and selectivity are obtained.

CONTROLS.—R. meter, silencer, tone, aerial trimmer, A.F. gain, selectivity, beat oscillator, receiver-send A.V.C. B.O. on/off; assembled with valves but unwired, £17; wired and aerial tested, £18/18.

ROTHERMEL Piezo High Fidelity Speakers.

MODEL R.95, 7in. cone, will handle 5 watts; 9/11.

MODEL R105, 10 1/2 in. cone, will handle 6 watts; 11/6.

ABOVE can be Used in Conjunction with Existing Moving Coil Speaker, connect across primary of speech transformer; to use independently a choke must be connected between the receiver or amplifier output; in the event of push-pull connect to the 2 anode terminals of output transformer, ignoring C.T.

T.C.C. 8 mid. 450-volt Working. Wet Electrolytics, can type, 1 hole fixing; 1/6 each.

POLAR 1/2 and 1/3 Resistances, good selection; 4/6 a gross.

PHILCO American Mains Transformers.—200-250-volt, 6.3-volt 3-amp., 5-volt 2-amp.; 7/6 each.

BRITISH Belmont.

RECEIVERS and Chassis Still Available from Stock; as previously supplied.

RECEIVERS, with valves; £7/7.

CHASSIS, with valves; £5/19/6.

ALL Lines Previously Advertised Still in Stock.

ALL Orders Over 5/- Carriage Free; under this amount sufficient postage must be included with order.

ALL Enquiries Must Enclose 1/4d. Stamp.

R. RADIO CLEARANCE, Ltd., 63, High Holborn, W.C.1. Telephone: Holborn 4631. [8593]

NEW RECEIVERS AND AMPLIFIERS

* **DEGALLIER'S** "Challenge Radio Corporation."
SEND 2d. stamp for Handsome Illustrated Catalogues. Telling of our Superb Range of Receivers; direct public sales policy (saves you 40%), most exceptional value on the market, from a T.R.F. Midget at £3/5 to a 19-valve general purpose receiver, 6 bands, with two P.A. speakers, at 30 gns.; 6-page brochure of *Wireless World* report on this set is available; car radio; any known American valve, all 5/6 each; also American P.A. speakers, cabinets, and the Challenger 6-valve A.C. tuning unit, 5 bands 6-10, 12.8-50, 65-200, 190-550, 900-2,000 metres. Hours business 11 a.m. until 9.30 p.m.

DEGALLIER'S 31, Craven Terrace, London, W.2. Paddington 6492. Nearest point Lancaster Gate Tube Station. [8515]

HOWARD 438 8-tube 4-band Communication Receiver. 7-550 metres, with matched crystal and R. meter; £19/19.—Superadio, Dantzic St., Manchester. [8510]

ARMSTRONG Co.—After many years at our old premises at Camden Town we have removed to a new building in Walters Rd., Holloway, N.7 (see displayed advertisement).

ARMSTRONG Amplifier Division Has Removed to New Premises at 94, Camden Rd., N.W.1. Enquiries for High Fidelity amplifiers and simple feeder units should be made to this address. Catalogue of this apparatus will be forwarded free to those interested.

ARMSTRONG Co. (Amplifier Division), 94, Camden Rd., N.W.1. [8518]

RECEIVERS AND AMPLIFIERS CLEARANCE, SURPLUS, ETC.

A.C. Three-stage P.P. Amplifier. G.12 speaker; £4.—Harper Radio, Moor St., West Bromwich. [8581]

AMAZING Offer.—Famous 7-valve push button 1939 models, in makers' sealed cartons, listed 13 1/2 gns.; £5/19/6.—Shippers, 18, Corporation St., Manchester. [0636]

Wanted

WANTED, Communication Receiver, 1,000v. 100 m.a. transformer, moving coil mike, small drill press.—Ei8n, Longford, Eire. [8563]

USED SETS FOR SALE

McMURDO

McMURDO Silver-Masterpiece VI Chassis, 18in. speaker, shop soiled only; £39/10.—A.C.S. Radio, 16, Gray's Inn Rd., W.C.1. [8572]

MIDWEST

MIDWEST 18 Valve Chassis, 6-band, 5-2,000 meter, with valves and speaker; £12.—Box 111, c/o *The Wireless World*. [8578]

TO SERVICE MEN

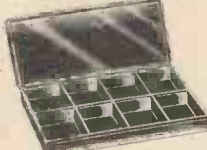

Bargain Offer!!!

A SERVICE KIT FOR 17/6

This Service Kit comprises:

- 4 VOLUME CONTROLS. 20,000, 50,000, 1 meg., 1 meg.
- 72 RESISTORS. Assorted, colour coded resistors, 1 to 3 watts.
- 2 DOZ. CONDENSERS. Assorted tubular, electrolytic and mica condensers.
- 1 STEEL CABINET. A very useful steel cabinet with partitions for above, screws, etc.

VALUE £4 for 17/6

KIT No. 2 comprising resistors and condensers only, as above 12/6

KIT No. 3 comprising volume controls and cabinet only 6/6

SPECIAL OFFER!!!

Fully shrouded Transformers by America's largest manufacturer. While they last.

All 230 v. primary and fully impregnated.	
T25708—375/375 v. 150 m/A., 6.3V5A, 2.5V2A, 5V3A	15/-
T19610—350/350 v. 150 m/A., 2.5V6A, 2.5V2A, 5V3A	12/6
T7236—375/375 v. 120 m/A., 6.3VCT. 4A, 5V3A	10/6
T7326—350/350 v. 100 m/A., 6.3VCT. 3A, 5V3A	8/6
T7307—350/350 v. 80 m/A., 6.3VCT. 3A, 5V3A	7/6
T7000—320/320 v. 80 m/A., 6.3V4A, 5V3A	7/6
T6025—320/320 v. 80 m/A., 2.5V6A, 5V3A	7/6
T46491D—10V4A Primary Tapped 110-230 v.	5/6
T113AB—110/230 v. 500 watt Auto Transformer	29/3
The following chokes are interleaved and impregnated.	
T7007—250 m/A., 135 ohms, 20-8 Hy., cadmium shrouded	12/6
T7007A—150 m/A., 250 ohms, 30-12 Hy., cadmium shrouded	12/6
100 m/A., 20 Hy., 500 ohms, unshrouded	4/11
60 m/A., 15 Hy., 250 ohms	1/11

RADIOMART Telephone: MIDland 3254.
 44, HOLLOWAY HEAD, BIRMINGHAM

USED SETS FOR SALE

NATIONAL

NATIONAL NC-44, hardly used, complete set of extra valves, McMurdo Diversity Coupler, new.—Box 95, c/o The Wireless World. [8573]

TROPHY

TROPHY Eight, with moving coil R-meter, loud speaker, three months old; £10.—20, Victoria Mansions, Chambers Lane, Willesden. [8592]

CAR RADIO

1939 Models from 4½ gns.; 6 new car aerials, from 9/6; trade enquiries solicited; lists free.—Shippers, 18, Corporation St., Manchester. [0622]

FINEST American Twin Running-board, Aerials, completely rubber covered, maximum signal pick-up, minimum noise, easy mounting, now only 17/6 pair complete; handsome chromium roof aerials, to mount straight or "vee," complete, 15/-; immediate despatch, carriage paid; cash with order or c.o.d.

WIRELESS SUPPLIES UNLIMITED, Essex House, Stratford, E.15. Maryland 3191. [0577]

PUBLIC ADDRESS

VORTEXION P.A. Equipment.

LIMITED, but unequalled.

WE Invite You to a Demonstration.

A.C.-D.C. Dance Band Amplifier, 10 watts output, complete in case, with moving coil microphone, speaker and cables, weight 22lb.; 12 gns.

A.C. 20 15-20-watt Amplifier, 38-18,000 cycles, independent mike and gram, inputs and controls, 0.037 volts required to full load, output for 4, 7.5, and 15 ohms speakers or to specification, inaudible hum level; ready for use; 3½ gns., complete.

C.P. 20, 12-volt battery and A.C. mains model, as used by R.A.F., output as above; 12 gns.

A.C. 20, in portable case, with Collaro motor, Piezo pick-up, etc., £14; C.P. 20 ditto, £17/17.

50-WATT Output 6L6s, under 60-watt conditions, with negative feed back, separate rectifiers for anode screen and bias, with better than 4% regulation, level response, 20-25,000 cycles, excellent driver, driver transformer, and output transformer matching 2-30 ohms impedance electronic mixing for mike and pick-up, with tone control, complete with valves and plugs; £15.

COMPLETE in Case, with turntable B.T.H. Piezo pick-up and shielded microphone transformer; £20.

80-WATT Model, with negative feed back; £25, complete.

120-WATT Model, with negative feed back; £40, complete.

250-VOLT 250 m.a. Full Wave Speaker, field supply unit; 25/-, with valve.

ALL P.A. Accessories in Stock; trade supplied.

VORTEXION, Ltd., 182, The Broadway, Wimbledon, S.W.19. Phone: Lib. 2814. [8241]

"PARTRIDGE P.A. Manual," free to trade, from N. Partridge, B.Sc., A.M.I.E.E., King's Buildings, Dean Stanley St., London, S.W.1. [0631]

AMPLIFYING Equipment, P.A. vans for sale or hire. Booklet on request.—Alexander Black† Ltd., 55, Ebury St., S.W.1. Sloane 6129. [0599]

QUALITY Amplifiers and Microphone Equipments for Hire or Permanent Installation.—Harmony House, 116, Cambridge Rd., Southport. [8505]

PUBLIC Address Contractors Can Hire P.A. Vans, loud speakers, microphones and equipments of all types from Hire Dept., Gramplan Reproducers, Ltd., Kew Gardens, Surrey. Tel.: Richmond 1175-6-7. [0618]

NEW MAINS EQUIPMENT

VORTEXION Supply G.P.O., B.B.C., L.P.T.B. Why not you?

ALL Models Super Shrouded, primaries screened and tapped, 200-250v., filaments C.T.

ANY Model Fitted 5v. or 6.3v. Filaments if Required.

500-0-500 150 m.a., 4v. 4a., 2.5a., 4v. 2a., 4v. 2a., 4v. 2a., 35/-; 400 or 350v., same price.

500-0-500 120 m.a., 4v. 4a., 4v. 2.5a., 4v. 1-2a., 4v. 1-2a., 28/-; 400v. or 450v., same price.

425-0-425 150 m.a., 4v. 8-10a., 4v. 2.5a., 4v. 1a., 4v. 1a., 32/-.

350-0-350 120 m.a., 4v. 4a., 4v. 2.5a., 4v. 1-2a., 21/-; with extra 4v. 6a., 25/-.

350-0-350 75 m.a., 4v. 2-4a., 4v. 1-2a.; 18/-.

250-0-250 60 m.a., 4v. 2-4a., 4v. 1-2a.; 15/-.

AUTO Transformers, 100-120 to 200-240v., 80 watts, 11/-; 120 watts, 14/6; 200 watts, 21/-; 250 watts, 25/-; 300 watts, 28/-; 500 watts, 47/6.

W.W. Q.A. Output Transformer; 21/-.

MICROPHONE Transformers, in heavy magnetic shielding 12/6.

CHOKES.—30h. 60 m.a., 7/6; 7-13h., 120 m.a., 12/6; 30h. 150 m.a., 15/-; 25h. 150 m.a., 21/-.

TRANSFORMERS and Chokes to Any Specification,

CAR Battery Charger, 6 and 12v., 1½ to 2 amperes; 30/- complete.

VORTEXION, Ltd., 182, The Broadway, Wimbledon, London, S.W.19. Telephone: Liberty 2814. [8591]

PREMIER

RADIO

Specified for "The Wireless World"

INEXPENSIVE RECORDING AMPLIFIER

- 2 TRIAD 6L6g Tubes 6/6 each
- 1 TRIAD 83 Tube 5/6 "
- 2 PREMIER Octal Valveholders... .. 9d. "
- 1 PREMIER U.X. Valveholder 6d. "

Let us quote for the Complete Kit.

STOCKTAKING SALE

SPECIAL

CLEARANCE OFFERS!

POTENTIOMETERS WITH SWITCH, ½ meg., 1 meg., 20,000 ohms and 10,000 ohms, 1/3 each.

POTENTIOMETERS WITHOUT SWITCH, 2 meg., 1 meg., ½ meg., 400,000 ohms, 25,000 ohms, 20,000 ohms, 10,000 ohms, 1/- each.

SPECIAL OFFER—CONTINENTAL MAINS VALVES, 4v. AC Typas, 5-pin only, AC/HL, AC/L, AC/P, AC/SG, AC/NMS, AC/HP, AC/VHP, 2/6 each. 20v. 18a AC/DC Types, SG. Var. Mu. SG. Power, HF Pen., 2/- each.

U.S.A. Typas, 24, 30, 41, 39/44, 35/51, 55, 56, 57, 58, 7k, 77, 85, 80, 2A5, 2A6, 2A7, 2B7, 6A7, 12Z3, 210, 250, all 2 for 3/-.

TUBULAR CONDENSERS, .002, .0001, .0003 and .0005 mfd., 1/- doz. Your choice.

ELECTROLYTIC CONDENSERS. Metal Can. 8 mfd. 320 volts, 2 for 1/6. 8 + 8 mf. 475v. + 10 mf. 50v., 2 for 2/6. 8 + 8 mf. 450v. + 8 mf. 250v., 2 for 2/6.

T.C.C. DRY ELECTROLYTICS. 8 + 8 + 4 mf. 500v., 2/- each.

LISSEN Power Packs in aluminium cases, 150 v., 25 m.a., with 6.3 v. L.T., 100-250 v. mains, 10/6, with Rectifier. MORSE KEYS. Excellent brass movement on bakelite base, 2/9 each.

BENJAMIN "CLASS B" Output Chokes, 1/6 each.

PREMIER Heavy Duty Class B Driver Transformers, 5/- each.

PREMIER MOVING COIL METERS

Guaranteed Accuracy within ± 2 per cent.

Model No. 21.	Model No. 311.
3in. square case.	3½in. diameter round case.
0-1 m/A. 18/6	0-1 m/A. 22/6
0-10 m/A. 17/6	0-10 m/A. 20/-
0-50 m/A. 17/6	0-50 m/A. 20/-
0-100 m/A. 17/6	0-100 m/A. 20/-
0-250 m/A. 17/6	0-250 m/A. 20/-

Model 311. 0-1 m/A. movement, with calibrated scale, volts-ohms-m/A., 25/-.

VOLTAGE MULTIPLIER RESISTANCES. Guaranteed accuracy ± 2 per cent. All standard ranges, 1/3 each. TAPPED SHUNT to provide readings of 5 m/A., 25 m/A., 250 m/A., and 1,000 m/A., 5/6.

PREMIER SHORT-WAVE KITS.

Complete to the last detail including all Valves and coils, as well as theoretical and wiring diagrams and lucid instructions for building and working. Each kit is supplied with a steel Chassis and Panel and uses plug-in coils to tune from 13 to 170 metres.

1 Valve Short-Wave Receiver or Adapter Kit ... 17/6

1 Valve Short-Wave Superhet Converter Kit ... 20/-

1 Valve Short-Wave A.C. Superhet Converter Kit 22/6

2 Valve Short-Wave Receiver Kit 25/-

3 Valve Short-Wave Screen Grid and Pentode Kit. 58/6

PREMIER U.S.A. QUARTZ TRANSMITTING CRYSTALS 7 mc Band, 10/- each, with Calibration Certificate. Enclosed holder and Base, 3/-.

PREMIER SHORT-WAVE COILS, 4- and 6-pin types, 13-26, 22-47, 41-94, 78-170 metres, 1/9 each, with circuit. Special set of S.W. Coils, 14-150 metres, 4/- set, with circuit. Premier 3-band S.W. coil, 11-25, 10-48, 38-80 metres. Suitable any type circuit, 2/6.

UTILITY Micro Cursor Dials, Direct and 100.1 Ratios, 3/9. PREMIER Short-Wave Condensers, all-brass construction, with Trolitul insulation. 15 mmf., 1/6; 25 mmf., 1/7; 40 mmf., 1/9; 100 mmf., 2/-; 160 mmf., 2/3; 250 mmf., 2/6.

TROLITUL DOUBLE SPACED TRANSMITTING CONDENSERS. 15 mmf., 2/9; 40 mmf., 3/6; 100 mmf., 4/-; 160 mmf., 4/6.

NEW TROLITUL SPLIT STATOR CONDENSERS, 50 x 50 mmf., 10/6.

COIL FORMERS, 4- or 6-pin low-loss, 1/- each.

Orders 5/- and over sent Post Free. Under 5/- please add 6d. Postage.

Have you had our 1939 Catalogue, Handbook and Valve Manual? 790 pages of Radio Bargains and Interesting Data. Price 6d.

ALL POST ORDERS TO: Jubilee Works, 167, Lower Clapton Road, London, E.5. Amherst 4723.

CALLERS TO: Jubilee Works, or our NEW PREMISES, 169, FLEET STREET, E.C.4. Central 2833.

or 50, High Street, Clapham, S.W.4. Macaulay 2381.

NEW LOUD-SPEAKERS

SINCLAIR Speakers for All Types.—Alma Grove, Copenhagen St., N.1. [0603]

SAVE Pounds.—1½d. stamp for list British and American P.A. Speakers.—Degallier's, 31, Craven Terrace, London, W.2. [8554]

BAKER'S New Corner Horn Speakers, triple cone conversions, from 29/6; and surplus speaker bargains.—Details free from Bakers Selhurst Radio, 75, Sussex Rd., South Croydon. [8512]

LOUD-SPEAKERS

SECOND-HAND, CLEARANCE, SURPLUS, ETC.

VAUXHALL UTILITIES, 163a, Strand, W.C.2.—Rola, G12 P.M. speakers, 62/6; G12 energised, 50/-; with transformers, brand new. [8585]

3,000 Speakers from 5/6 each, P.M. and energised, 4in. to 14in., including several Epoch 18in.—Sinclair Speakers, Alma Grove, Copenhagen St., N.1. [0591]

LOUD-SPEAKER CONVERSIONS

EPOCH Domino Loudspeakers Can Now be Converted to the Famous "NEW" Super Cinema Speaker with 14in. Cone, replacement for all Epoch speakers, also output transformers; a genuine Epoch hand-made cone for any speaker.

HALFORD DISTRIBUTORS, Ltd., 31, St. George St., W.1.—Sole manufacturers of Epoch loudspeakers and the famous Halford Phantom radio set. [0632]

TRANSMITTING APPARATUS

A.C.S. RADIO, specialists in short-wave apparatus, communication receivers, including Hallicrafters, National and R.M.E. transmitting equipment, valves and components.—Send for free catalogue to A.C.S. Radio, 16, Gray's Inn Rd., W.C.1. Holborn 9894-5. G2NK, Technical Manager. [0550]

G5NI.—The oldest and largest distributor of amateur equipment, transmitting and receiving; short-wave catalogue, 1½d.; G5NI 70-page Manual, 7½d., post free; authorised direct distributor for Collins, National, R.M.E., Thordaxson, Hammerlund, Biley, Taylor, Eimac, etc., etc.—44, Holloway Head, Birmingham. [0531]

CABINETS

A CABINET for Every Radio Purpose.

CONVERT Your Set into a Radiogram at Minimum Cost; surplus cabinets from noted makers under cost of manufacture (undrilled); 30/- upwards; motors at wholesale prices.

"FIT-A-GRAM" Cabinet, 31 x 17 x 15; 21/-.

UNDRIILLED Table Console and Loud-speaker Cabinets from 3/6.

INSPECTION Invited; photos loaned to country customers.

H. L. SMITH and Co., Ltd., 289, Edgware Rd., W.2. Tel.: Pad. 5891. [0485]

CLEARANCE SALE!—Radiogram and television cabinets, prices slashed! 10 gns. worth for 50/-! 5 gns. worth for 20/-!—Write, wire, phone or call, Cameo Co., 23, Denmark St., W.O.2. (Tem. 5900.) [8527]

DEGALLIER'S for the Finest Obtainable American Cabinets, Table, Console and Radio Grams; also Record Changers, 5 gns. Send 1½d. stamp for reprints from actual photographs.—Degallier's 31, Craven Terrace, Lancaster Gate, London, W.2. [8553]

DYNAMOS, MOTORS, ETC.

D.C.-A.C. Convertors, motors, all voltages, for sale and wanted.—Easco, 18w, Brixton Rd., S.W.9. [0558]

ALL Types of Rotary Convertors, electric motors, battery chargers, petrol-electric generator sets, etc., in stock, new and second-hand.

A.C.-D.C. Conversion Units for Operating D.C. Receivers from A.C. Mains, 100 watts output, £2/10; 150 watts output, £3/10.

WARD, 46, Farringdon St., London, E.C.4. Tel.: Holborn 9703. [0518]

ELECTRADIX Rotary Convertors for A.C. Radios on D.C. mains; alternators 50 to 500 cycles; mains motors and motor generators for 1 to 600 cycles; petrol engines and switchgear.—218, Upper Thames St., London, E.C.4. [0619]

Wanted

ROTARY Converter, input 25 volt D.C., output 200-250 volt A.V., 100-150 watts; must be cheap.—Jackson, Birkenhead, Larkhall, Lanarkshire. [8582]

RECORDING EQUIPMENT

ALL Recording Discs and Materials in Stock; tracker units, £4/7/6; recording motors, £3/17/6.—Write for further details. Will Day, Ltd., 19, Lisle St., W.C.2. [0595]

VALVES

ALL Types of American Tubes in Stock of Impex and Areturus makes at competitive prices.

WE Can Also Supply a Full Range of Guaranteed Replacement Valves for Any British non-ring, American or Continental type at an appreciably lower price.

SEND for Lists of These, and also electrolytic condensers, line cords, resistances, etc.

CHAS. F. WARD, 46, Farringdon St., London, E.C.4. Tel.: Holborn 9703. [0452]

AMERICAN, 2/9; 1,000 non-ring British, from 1/9; bargains galore; lists free.—Shippers, 18, Corporation St., Manchester. [0607]

METROPOLITAN RADIO SERVICE.—Special offer. American valves, in makers' cartons, 3/- each; Octals, 3/6 each; American valves, first grade, in all types; trade supplied.—1921, Finchley Rd., N.W.11. Speedwell 3000. [0436]

COMPONENTS

SECOND-HAND, CLEARANCE, SURPLUS, ETC.

PREMIER SUPPLY STORES.

PLEASE See Our Displayed Advertisement on page 3. [0488]

RYALLS RADIO, 280, High Holborn, London, W.C.1, offer new goods, post free.

ELLIPTICAL Speakers, Celestion, suitable Ekco replacements, 750 and 1,250 ohms, less transformers, speech 25 ohms, new, handle 8 watts, carry up to 120 m.a.; 5/6 each.

AMPLIFIERS, A.C. 200-250v. output 16 watts A.C. from pair 6L6 in push pull, 3 stage, ample volume for driving extra speakers available. Complete with valves, and pair of elliptical speakers, wired up ready for use; 72/6, carriage paid.

GARRARD AC Induction Type AC7a Gramophone Motors, with pick-ups complete, 200-250v., 12in. turntable and unit plate, auto. stop, speed regulator, new; 32/6 each.

SPEAKERS, pairs, brand new, elliptical cone speakers, made by first class firm, quality of reproduction outstanding, push-pull pentode transformer, fields 325-ohm for smoothing choke, 8,600 as bleeder, circuit available, handle 10-15w.; 14/- pair.—Ryalls Radio, see above. [8374]

RADIO SUPPLIES Score Again by Offering the Following Lines at a Fraction of the Original Cost.

THE Latest 1939 Automatic 5-valve Car Radio, 3 watts output, tone control, 8-volt operation, consumption 3 amps., complete with all suppressors, all in sealed cartons; £4 each.

THE Latest 1939 Automatic 6-valve Car Radio, 3 1/2 watts output, 2 wave-bands, 6-volt operation, consumption 3 1/2 amps., complete with all suppressors, all in sealed carton; £5/5 each.

6-VOLT Dropping Resistors for Car Radios, 3/6 each; streamline, overhead aerials, finest make, chromium finish, 9/- each.

12 Only—Lissen and Ever Ready, Band Pass 4; all-wave, A.C. receivers, 1937-38 model, 4 watts output, complete with valves, perfect working order; £1/17/6 each.

3 ONLY. Ever Ready 5-valve superhet., A.C., all-wave 1938 model, brand new; a snip, £3 each.

2 ULTRA 50, 6-valve superhet. A.C., all-wave, 1938-39 model, slightly shop soiled cabinet; £3.15 each.

1 ULTRA 115, 4-valve Superhet., A.C., all-wave, 1938 model, perfect condition; £3/10.

2 EKCO A.W.88 5-valve Superhet., 4 wave-bands, spin wheel tuning, 1938-39 model, brand new; £4 each.

2 ONLY—1939 Emerson Midgets, with electric clock, ivory cabinet; £3 each.

JUST Arrived—Emerson 5-valve Superhet. Midgets, medium and long waves, A.C./D.C., 110-250 volt, beam power output, brown or ivory cabinet, all in sealed carton; £3/5 each.

A FEW Ever Ready 4-valve Superhet, Battery Sets, 1937-38 model, complete with valves, perfect order; £1/12/6 each.

RADIO Record H.F. Pens, equivalent to Mazda, AC/VP1, boxed, 3/- each; Radio Record rectifiers, equivalent to Osram U.12, 2/9 each.

BELMONT First Grade American Valves, boxed, types available 80, 606, 42, 43, 18E, 75 and 78; 2/6 each.

R. and A. (Philco) Mains Energised Speakers, 8in. cone, complete with transformer, brand new, 2/9 each; matched pairs, 5/-.

BRAND New Decca Mains Transformers, 200-250 volt primary, 350.0-350 volt 120 m.a. sec., 4 volt 2.5 amp., 4 volt 7 amp., 15 volt 2 amp., screened primary; 3/- each.

MAGNAVOX and Blue Spot Output Transformers, 2/- each; the finest make, 8 mid., 500 volt, tubular Midgets, condenser, 1/- each, 10/6 a dozen.

BRAND New Plessey-Mallory Condenser Banks, capacity 6+4+50 mid., 450 volt working; 7/6 a dozen.

CENTRALAB Pots, long spindle, less switch, sizes available 10,000 and 50,000 and 500,000; 1/- each.

ROLA G.12 P.M.s. with multi radio transformer, boxed, £2/12/6; brand new 7-pin H.F. Pentodes, equivalent to Mullard S.P.4, first grade, 3/- each.

PHILIPS Pots, long spindle, mixed sizes, 3/- a dozen; Tungstam, double diodes, brand new, 5/- a dozen.

6 ONLY—Ever Ready Band Pass 3 battery sets, H.F. Pentode, d.c.t., output Pentode, complete with valves, perfect; £1/7/6.

3 ONLY—Colonial 9-valve chassis, with Magnavox 12in. auditorium speaker, 10 watts output, 5 wave-bands, band spread tuning, electric eye tuning indicator, negative feed back; special offer, £8/7/6.

SPECIAL Trade List for Dealers. A suitable amount must be included to cover postage.—Radio Supplies, 22, Faraday Ave., Manchester, 8. Tel.: Col. 1261. [8579]

VAUXHALL—Hivac valves, all types. Standard capacity bar type condensers, trimmers, 2-gang, 7/6.

VAUXHALL—T.C.C. dry, 8 mid., 2/6; 600v. aluminium containers; T.C.C. 600v. dry, cardboard containers, 8 mid., 1/9.

VAUXHALL UTILITIES. 163a, Strand, W.C.2.—Ask for free list; sheet aluminium, 12in.x12in., 3/-; 12in.x18in., 4/- [8586]

SOUTHERN RADIO, 46, Lisle St. London, W.C. Ger-rard 6653.—Stocks of receivers and replacement components, as previously advertised. [8548]

OLIVERS Offer Aluminium Chassis, 18 s.w.g., 16in.x10in.x3in., 6/6; any size to order.—Olivers, 676, Christchurch Rd., Boscombe, Hants. [8580]

COLLARO A.C./D.C. Record-changers, 200-250, plays eight 10in. or 12in. records, mixed, also incorporates repeater and retractor; limited quantity, £5/5, in sealed cartons.

HENRY'S, 72, Wellington Av., Stamford Hill, N.15, Stamford Hill 2907. [8216]

ELECTRADIX BARGAINS!!!

MERCURY "LESDEX" MERCURY SWITCHES

will operate with the same characteristics almost indefinitely, because they are hermetically sealed and absolutely gas tight.

SWITCHES

S.P. MERCURY CONTACT TUBES, 5 amps., 4-; 10 amps., 5-; 200 amps., cheap.

15-DAY TIME SWITCHES. Venner 1 amp., 5 amps., 50 amps., 100 amps., 200 amps., cheap.

EMERGENCY ENGINE SETS. Stuart petrol-electric sets, water-cooled, coupled to 30 volts 5 amp. dynamo, £21. 50 volts 10 amps., £17. Portable air-cooled engine sets, 2 1/2 kW. for field charging.

EDISON Steel Storage Cells. DYNAMOS and Switchboards from 50 watts to 50 kW. Morse chains and wheels, 5- set. Buzzer boxes, 1 hp. 10-.

RELAYS. Selector 25 way, 8 gang. Auto, 10-. Single-blade No. 1 Relay, 1,000 ohms, 8/8. No. 2, 2,000 ohms, 8-. C.O. Relays, No. 5, polarised 8/6 and so on. 16 distinct types in stock. Transmitters Relays, Souder Type, 5 amps., 15-. Hipower Ham Relays, 7/6. Ship Magnetic, 15-. Creed Polarised, 2-way, 25-. Ask for Relay brochure "8.W."

SUPERSENSITIVE MOVING COIL RELAYS. For operation on microamps. Small panel 2 1/2 in. 50 m/m. Relay W.1 for photo cells, 55-. Lab. type Moving Coil Relays. Centre of 2 contacts. Paul & Weston (used). Fully guaranteed. Half price. Mains relay overload trip, 7/6.

THE "LESDEX BIJOU" ELECTRIC WATER PUMP is a centrifugal, all-bronze pump. 2 1/2 in. dia. 120 gals. per hour. Throws jets 10ft. Runs for 20 hours for a unit. A.C. or D.C., any voltage supplied; or 12 or 50 volts D.C. Costs only 67/6. Supplied in hard-wood case for 5/- extra. Twin Piston Cepasop Pumps. Type "MET" "R" with electric motor, 25 10s.

MOTOR BLOWERS. Fume Exhauster and Air Circulators. Strong iron body, 2 1/2 in. fan, outlet, direct coupled to motor, A.C. 220-v., 65-; 110-v. D.C., 45/-; D.C. 220-v., 55/-.

BUZZERS. Buzzers for Signals, Wave-meters or Testing. High Note Platinum contacts. List 10-. Sale, 6-. High Note "D.M." Buzzer in case, 3/6. Service Buzzer, No. 24, 12/8. D.H. Double Circuit Twin Buzzers, 10/-.

BELLS. ALARM BELLS. Mains, battery or magneto waterproof types. 1,000 British House Bells, wall and table. Priority for A.R.P. A.R.P. workers and especially Hama may want portable H.T. for emergency outdoor field transmitters. Portable Hand Generators in tank cases by Evershed. 800 and 1,000 volts D.C.

TELESCOPES. Navy Telescopes, hand spotters, 25-. Gun type, 17/6. MAGNETIC 1 1/2 in. COMPASS with Plain Scale. Bevel glass, brass body. A British Bargain for 9d. only.

TRANSMITTERS SHIP KEYS with massive contacts, 21/6. First-class Keys, balanced movement and heavy contacts of gold-silver, tungsten, etc. Panel Keys to fold up. 6/6. Fullerphone double acting Keys, 6/6. 51KBSL R.A.F. Morse Key, solid lacquered brass on mahogany base, 7/6. Three-colour-light Switch Box with Morse key for code signals, 4/6.

Radio Key, 31K, 21/6. PARCELS of experimental coils, magnets, wire, chokes, mikes, condensers, switches, terminals, etc., post free, 10 lbs., 7/-; 7 lbs., 5-. 1,000 other Bargains in New Sale List.

67/6

coupled to motor, A.C. 220-v., 65-; 110-v. D.C., 45/-; D.C. 220-v., 55/-.

TELESCOPES. Navy Telescopes, hand spotters, 25-. Gun type, 17/6. MAGNETIC 1 1/2 in. COMPASS with Plain Scale. Bevel glass, brass body. A British Bargain for 9d. only.

TRANSMITTERS SHIP KEYS with massive contacts, 21/6. First-class Keys, balanced movement and heavy contacts of gold-silver, tungsten, etc. Panel Keys to fold up. 6/6. Fullerphone double acting Keys, 6/6. 51KBSL R.A.F. Morse Key, solid lacquered brass on mahogany base, 7/6. Three-colour-light Switch Box with Morse key for code signals, 4/6.

Radio Key, 31K, 21/6. PARCELS of experimental coils, magnets, wire, chokes, mikes, condensers, switches, terminals, etc., post free, 10 lbs., 7/-; 7 lbs., 5-. 1,000 other Bargains in New Sale List.

TELESCOPES. Navy Telescopes, hand spotters, 25-. Gun type, 17/6. MAGNETIC 1 1/2 in. COMPASS with Plain Scale. Bevel glass, brass body. A British Bargain for 9d. only.

TRANSMITTERS SHIP KEYS with massive contacts, 21/6. First-class Keys, balanced movement and heavy contacts of gold-silver, tungsten, etc. Panel Keys to fold up. 6/6. Fullerphone double acting Keys, 6/6. 51KBSL R.A.F. Morse Key, solid lacquered brass on mahogany base, 7/6. Three-colour-light Switch Box with Morse key for code signals, 4/6.

Radio Key, 31K, 21/6. PARCELS of experimental coils, magnets, wire, chokes, mikes, condensers, switches, terminals, etc., post free, 10 lbs., 7/-; 7 lbs., 5-. 1,000 other Bargains in New Sale List.

TELESCOPES. Navy Telescopes, hand spotters, 25-. Gun type, 17/6. MAGNETIC 1 1/2 in. COMPASS with Plain Scale. Bevel glass, brass body. A British Bargain for 9d. only.

TRANSMITTERS SHIP KEYS with massive contacts, 21/6. First-class Keys, balanced movement and heavy contacts of gold-silver, tungsten, etc. Panel Keys to fold up. 6/6. Fullerphone double acting Keys, 6/6. 51KBSL R.A.F. Morse Key, solid lacquered brass on mahogany base, 7/6. Three-colour-light Switch Box with Morse key for code signals, 4/6.

Radio Key, 31K, 21/6. PARCELS of experimental coils, magnets, wire, chokes, mikes, condensers, switches, terminals, etc., post free, 10 lbs., 7/-; 7 lbs., 5-. 1,000 other Bargains in New Sale List.

TELESCOPES. Navy Telescopes, hand spotters, 25-. Gun type, 17/6. MAGNETIC 1 1/2 in. COMPASS with Plain Scale. Bevel glass, brass body. A British Bargain for 9d. only.

TRANSMITTERS SHIP KEYS with massive contacts, 21/6. First-class Keys, balanced movement and heavy contacts of gold-silver, tungsten, etc. Panel Keys to fold up. 6/6. Fullerphone double acting Keys, 6/6. 51KBSL R.A.F. Morse Key, solid lacquered brass on mahogany base, 7/6. Three-colour-light Switch Box with Morse key for code signals, 4/6.

Radio Key, 31K, 21/6. PARCELS of experimental coils, magnets, wire, chokes, mikes, condensers, switches, terminals, etc., post free, 10 lbs., 7/-; 7 lbs., 5-. 1,000 other Bargains in New Sale List.

TELESCOPES. Navy Telescopes, hand spotters, 25-. Gun type, 17/6. MAGNETIC 1 1/2 in. COMPASS with Plain Scale. Bevel glass, brass body. A British Bargain for 9d. only.

TRANSMITTERS SHIP KEYS with massive contacts, 21/6. First-class Keys, balanced movement and heavy contacts of gold-silver, tungsten, etc. Panel Keys to fold up. 6/6. Fullerphone double acting Keys, 6/6. 51KBSL R.A.F. Morse Key, solid lacquered brass on mahogany base, 7/6. Three-colour-light Switch Box with Morse key for code signals, 4/6.

Radio Key, 31K, 21/6. PARCELS of experimental coils, magnets, wire, chokes, mikes, condensers, switches, terminals, etc., post free, 10 lbs., 7/-; 7 lbs., 5-. 1,000 other Bargains in New Sale List.

TELESCOPES. Navy Telescopes, hand spotters, 25-. Gun type, 17/6. MAGNETIC 1 1/2 in. COMPASS with Plain Scale. Bevel glass, brass body. A British Bargain for 9d. only.

TRANSMITTERS SHIP KEYS with massive contacts, 21/6. First-class Keys, balanced movement and heavy contacts of gold-silver, tungsten, etc. Panel Keys to fold up. 6/6. Fullerphone double acting Keys, 6/6. 51KBSL R.A.F. Morse Key, solid lacquered brass on mahogany base, 7/6. Three-colour-light Switch Box with Morse key for code signals, 4/6.

Radio Key, 31K, 21/6. PARCELS of experimental coils, magnets, wire, chokes, mikes, condensers, switches, terminals, etc., post free, 10 lbs., 7/-; 7 lbs., 5-. 1,000 other Bargains in New Sale List.

TELESCOPES. Navy Telescopes, hand spotters, 25-. Gun type, 17/6. MAGNETIC 1 1/2 in. COMPASS with Plain Scale. Bevel glass, brass body. A British Bargain for 9d. only.

TRANSMITTERS SHIP KEYS with massive contacts, 21/6. First-class Keys, balanced movement and heavy contacts of gold-silver, tungsten, etc. Panel Keys to fold up. 6/6. Fullerphone double acting Keys, 6/6. 51KBSL R.A.F. Morse Key, solid lacquered brass on mahogany base, 7/6. Three-colour-light Switch Box with Morse key for code signals, 4/6.

Radio Key, 31K, 21/6. PARCELS of experimental coils, magnets, wire, chokes, mikes, condensers, switches, terminals, etc., post free, 10 lbs., 7/-; 7 lbs., 5-. 1,000 other Bargains in New Sale List.

TELESCOPES. Navy Telescopes, hand spotters, 25-. Gun type, 17/6. MAGNETIC 1 1/2 in. COMPASS with Plain Scale. Bevel glass, brass body. A British Bargain for 9d. only.

TRANSMITTERS SHIP KEYS with massive contacts, 21/6. First-class Keys, balanced movement and heavy contacts of gold-silver, tungsten, etc. Panel Keys to fold up. 6/6. Fullerphone double acting Keys, 6/6. 51KBSL R.A.F. Morse Key, solid lacquered brass on mahogany base, 7/6. Three-colour-light Switch Box with Morse key for code signals, 4/6.

Radio Key, 31K, 21/6. PARCELS of experimental coils, magnets, wire, chokes, mikes, condensers, switches, terminals, etc., post free, 10 lbs., 7/-; 7 lbs., 5-. 1,000 other Bargains in New Sale List.

TELESCOPES. Navy Telescopes, hand spotters, 25-. Gun type, 17/6. MAGNETIC 1 1/2 in. COMPASS with Plain Scale. Bevel glass, brass body. A British Bargain for 9d. only.

TRANSMITTERS SHIP KEYS with massive contacts, 21/6. First-class Keys, balanced movement and heavy contacts of gold-silver, tungsten, etc. Panel Keys to fold up. 6/6. Fullerphone double acting Keys, 6/6. 51KBSL R.A.F. Morse Key, solid lacquered brass on mahogany base, 7/6. Three-colour-light Switch Box with Morse key for code signals, 4/6.

Radio Key, 31K, 21/6. PARCELS of experimental coils, magnets, wire, chokes, mikes, condensers, switches, terminals, etc., post free, 10 lbs., 7/-; 7 lbs., 5-. 1,000 other Bargains in New Sale List.

TELESCOPES. Navy Telescopes, hand spotters, 25-. Gun type, 17/6. MAGNETIC 1 1/2 in. COMPASS with Plain Scale. Bevel glass, brass body. A British Bargain for 9d. only.

TRANSMITTERS SHIP KEYS with massive contacts, 21/6. First-class Keys, balanced movement and heavy contacts of gold-silver, tungsten, etc. Panel Keys to fold up. 6/6. Fullerphone double acting Keys, 6/6. 51KBSL R.A.F. Morse Key, solid lacquered brass on mahogany base, 7/6. Three-colour-light Switch Box with Morse key for code signals, 4/6.

Radio Key, 31K, 21/6. PARCELS of experimental coils, magnets, wire, chokes, mikes, condensers, switches, terminals, etc., post free, 10 lbs., 7/-; 7 lbs., 5-. 1,000 other Bargains in New Sale List.

TELESCOPES. Navy Telescopes, hand spotters, 25-. Gun type, 17/6. MAGNETIC 1 1/2 in. COMPASS with Plain Scale. Bevel glass, brass body. A British Bargain for 9d. only.

TRANSMITTERS SHIP KEYS with massive contacts, 21/6. First-class Keys, balanced movement and heavy contacts of gold-silver, tungsten, etc. Panel Keys to fold up. 6/6. Fullerphone double acting Keys, 6/6. 51KBSL R.A.F. Morse Key, solid lacquered brass on mahogany base, 7/6. Three-colour-light Switch Box with Morse key for code signals, 4/6.

Radio Key, 31K, 21/6. PARCELS of experimental coils, magnets, wire, chokes, mikes, condensers, switches, terminals, etc., post free, 10 lbs., 7/-; 7 lbs., 5-. 1,000 other Bargains in New Sale List.

TELESCOPES. Navy Telescopes, hand spotters, 25-. Gun type, 17/6. MAGNETIC 1 1/2 in. COMPASS with Plain Scale. Bevel glass, brass body. A British Bargain for 9d. only.

TRANSMITTERS SHIP KEYS with massive contacts, 21/6. First-class Keys, balanced movement and heavy contacts of gold-silver, tungsten, etc. Panel Keys to fold up. 6/6. Fullerphone double acting Keys, 6/6. 51KBSL R.A.F. Morse Key, solid lacquered brass on mahogany base, 7/6. Three-colour-light Switch Box with Morse key for code signals, 4/6.

Radio Key, 31K, 21/6. PARCELS of experimental coils, magnets, wire, chokes, mikes, condensers, switches, terminals, etc., post free, 10 lbs., 7/-; 7 lbs., 5-. 1,000 other Bargains in New Sale List.

TELESCOPES. Navy Telescopes, hand spotters, 25-. Gun type, 17/6. MAGNETIC 1 1/2 in. COMPASS with Plain Scale. Bevel glass, brass body. A British Bargain for 9d. only.

TRANSMITTERS SHIP KEYS with massive contacts, 21/6. First-class Keys, balanced movement and heavy contacts of gold-silver, tungsten, etc. Panel Keys to fold up. 6/6. Fullerphone double acting Keys, 6/6. 51KBSL R.A.F. Morse Key, solid lacquered brass on mahogany base, 7/6. Three-colour-light Switch Box with Morse key for code signals, 4/6.

Radio Key, 31K, 21/6. PARCELS of experimental coils, magnets, wire, chokes, mikes, condensers, switches, terminals, etc., post free, 10 lbs., 7/-; 7 lbs., 5-. 1,000 other Bargains in New Sale List.

TELESCOPES. Navy Telescopes, hand spotters, 25-. Gun type, 17/6. MAGNETIC 1 1/2 in. COMPASS with Plain Scale. Bevel glass, brass body. A British Bargain for 9d. only.

TRANSMITTERS SHIP KEYS with massive contacts, 21/6. First-class Keys, balanced movement and heavy contacts of gold-silver, tungsten, etc. Panel Keys to fold up. 6/6. Fullerphone double acting Keys, 6/6. 51KBSL R.A.F. Morse Key, solid lacquered brass on mahogany base, 7/6. Three-colour-light Switch Box with Morse key for code signals, 4/6.

Radio Key, 31K, 21/6. PARCELS of experimental coils, magnets, wire, chokes, mikes, condensers, switches, terminals, etc., post free, 10 lbs., 7/-; 7 lbs., 5-. 1,000 other Bargains in New Sale List.

TELESCOPES. Navy Telescopes, hand spotters, 25-. Gun type, 17/6. MAGNETIC 1 1/2 in. COMPASS with Plain Scale. Bevel glass, brass body. A British Bargain for 9d. only.

TRANSMITTERS SHIP KEYS with massive contacts, 21/6. First-class Keys, balanced movement and heavy contacts of gold-silver, tungsten, etc. Panel Keys to fold up. 6/6. Fullerphone double acting Keys, 6/6. 51KBSL R.A.F. Morse Key, solid lacquered brass on mahogany base, 7/6. Three-colour-light Switch Box with Morse key for code signals, 4/6.

Radio Key, 31K, 21/6. PARCELS of experimental coils, magnets, wire, chokes, mikes, condensers, switches, terminals, etc., post free, 10 lbs., 7/-; 7 lbs., 5-. 1,000 other Bargains in New Sale List.

COMPONENTS—SECOND-HAND, CLEARANCE, SURPLUS, ETC.

MAINS RADIO DEVELOPMENT Co. Offer Immediate Delivery, carriage paid, call mornings; telephone Tudor 4046; stamp for list 227A; Transatlantic all-wave tuning packs now available from stock; stamp for details.

DUBILIER Mica Tag Condensers, 0.0005, 0.0001, 0.0002, 0.0003, 0.0005 mfd.; 3d., 2/6 dozen.

FRIE 1-watt Colour Coded Unused Resistors, any size, 50 ohms to 5 megohms, your selection; 3d., 2/6 dozen; 2-watt, 6d.

CENTRALAB Latest Potentiometers, long standard spindle, unused, all sizes, 5,000 ohms-2 megohms; 2/-, with mains switch 2/3.

TUBULAR Condensers, 400-volt working, wire ends, best make, 0.0001-0.05 mfd., 4d.; 0.1 mfd., 4d.; 0.25, 0.5 mfd., 6d.

CLIX Unused Chassis Valveholders, 5 pin, 7-pin, 3d. each; all American sizes, 6d. each; best sleeving, 1 1/2d. yard.

FIFTY Unused N.S.F. 1/4-, 1-, 2-watt Resistors, wire ends, marked, colour coded, 20 different useful sizes in each parcel; 50 for 2/6 only.

MAINS RADIO DEVELOPMENT Co., 4-6, Muswell Hill Rd., London, N.6. Tudor 4046. [8569]

Wanted

WANTED, surplus electrical goods.—Description, quantity and price to Box 9866, c/o *The Wireless World*, [8497]

WESTERN Electric Gramophone Pick-up, preferably off talkie machine; state price, condition, in reply.—Bradley, 20, Church Rd., Birmingham, 22. [8575]

WE Buy for Cash All Types of Modern Second-hand Radio Sets and Accessories, test meters, parts, etc. We pay more than any other dealer. Part exchanges. Bring, send or will call.—University Radio, Ltd., 238, Euston Rd., London, N.W.1. Phone: Euston 3810. [8538]

EXCHANGE

WANTED, capacity and inductance meters, also A.C. instantaneous reading wattmeter, cheap. Power amplifier components, dynamos and motors offered in exchange.—Wynn, Balsall Common, Coventry. [8570]

REPAIRS AND SERVICE

"SERVICE with a Smile."

AMERICAN Valves, spares, linecards, rewinds; repairers of all types of American and British receivers.—F.R.I., Ltd., 22, Howland St., W.1. Museum 5675. [0434]

LOUD-SPEAKER Repairs, British, American, any make, 24-hours service; moderate prices.—Sinclair Speakers, Alma Grove, Copenhagen St., N.1. [0590]

GUARANTEED Repairs Any Transformers, choke, motor armature, converter, dynamo, etc.; keenest prices, immediate quotation, prompt, dependable service.—See below.

L.T.P. (LONDON TRANSFORMER PRODUCTS, Ltd.), Willesden, N.W.10. Willesden 6486 (3 lines). [6892]

MAINS Transformer Service. Repairs, rewinds, or construction to specification of any type, competitive prices and prompt service.—Sturdy Electric Co., Dip-ton, Newcastle-on-Tyne. [0518]

METROPOLITAN RADIO SERVICE—Guaranteed repairs to American and British receivers; American valves, service parts and rewinds; trade supplied.—1021, Finchley Rd., N.W.1. Speedwell 3000. [0435]

DEGALLIER'S "Reliable Service With a

SITUATIONS VACANT

IMPERIAL AIRWAYS Require Radio Officers of British Nationality, aged 23-30, for universal service. **QUALIFICATIONS** Include Possession of P.M.G. Air Operator's W.T. Licence. Two years' previous marine or air operating experience desirable. Preference given to holders of 1st Class Marine Certificate. Basic Salary £4 10s. to £6 5s. per week, according to seniority, plus service pay and allowances according to base. Accident Insurance £1,000 provided. Contributory Pension Scheme. Applicants subject to examination by Company's Medical Officer.

WRITTEN Application, giving full details of age, experience and qualifications, should be made to the Flying Establishment Officer, Imperial Airways, Airways House, London, S.W.1. Please mark envelope SEO/L. [8571]

SALES Service Engineer; good prospects to right man; able to drive a car.—Full particulars to Ewell Court Electrical Ltd., 197, Kingston Rd., Ewell, Surrey. [8589]

LABORATORY Assistant Having Experience and Training in A.F. Amplification for Test Dept. in Large Progressive Organisation, West London, 5-day week.—Apply full particulars, Box 118, c/o *The Wireless World*. [8590]

RADIO Testers and Inspectors, experienced with receivers and/or transmitters, and associated equipment; top rates of pay to experienced men.—Write, stating age and experience, to Box 90, c/o *The Wireless World*. [8565]

QUALIFIED Radio and Television Development Engineer Required by manufacturing company in South East London.—Write, giving full particulars of age, experience, degrees and salary required, Box 97, c/o *The Wireless World*. [8564]

RADIO Valve Engineer (Junior) Required by Radio Valve Manufacturers in North London; some knowledge of valve and set circuits essential.—Write, stating age, experience, training and salary required, to Box 89, c/o *The Wireless World*. [8566]

SERVICE Engineer, fully experienced, to take charge of inside Service Dept., permanent position, commencing salary £200 p.a., state qualifications, practical and theoretical, age, references.—Apply, writing only, S. J. Clear and Co., Ltd., Dorking. [8577]

RADIO Manufacturers in S.E. London Require the Services of Two Good Development Engineers, for the design of mass produced broadcast receivers.—Write in confidence full details of experience, salary required and age, to Box 25, c/o *The Wireless World*. [8544]

TELEVISION Engineers and Production Men, with practical experience, required for development and production of Cathode Ray Tubes for domestic receivers.—Write in confidence full details of experience, age and salary required, to Box 26, c/o *The Wireless World*. [8545]

RADIO Test Operators, male, with experience in routine alignment or fault diagnosis of broadcast receivers, required immediately.—Apply by letter only, stating age, previous experience and remuneration expected, to Employment Dept., E. K. Cole, Ltd., Southend-on-Sea. [8551]

RADIO Valve Applications Engineer Required for Technical Department of Well-known Valve Manufacturer, should have extensive up-to-date experience and intimate knowledge of valves.—Write, stating age, experience and salary required, to Box 96, c/o *The Wireless World*. [8574]

TELEVISION Time Base Engineer Required With University Degree or Equivalent Qualifications, must have had industrial experience. Our own staff know of this advertisement.—Write in confidence, full details of experience, salary required and age, to Box 115, c/o *The Wireless World*. [8584]

PRODUCTION Engineer Required for Radio Factory, technical man with sound production experience essential, able to co-ordinate all departments and deliver output to schedule.—Write in confidence, giving full details of experience, salary required and age, to Box 114, c/o *The Wireless World*. [8583]

MECHANIC or Technician Required for Radio Receiving Valve Works, preference given to one with experience in handling automatic grid winding machines and able to control the output of the Grid Department.—Write in confidence full details of experience, age and salary required, to Box 27, c/o *The Wireless World*. [8546]

VACANCIES Exist for Civilian Wireless Instructors at the Electrical and Wireless School, Royal Air Force, Yatesbury, Wilt. The commencing rate of pay is £4 a week inclusive, which may be increased to £4 5s. a week after a short period of satisfactory service. Candidates must be capable of lecturing and must have a sound knowledge of electrical principles and their application to Radio and low-power electrical engineering. Applications should be addressed to the Commanding Officer, No. 2 Electrical and Wireless School, Yatesbury, Wilt., giving full particulars as to previous experience, age, etc. Candidates will be required to appear before a Selection Board at the School for interview and test. The test will include the giving of a lecture on any subject which may be chosen by the candidate involving the principles of modern radio. Lecturing sequence and style are most important. [0616]

SITUATIONS WANTED

WIRELESS Operator Seeks Relief Voyages, direct employment, experienced.—Box 112, c/o *The Wireless World*. [8576]

SENIOR Radio Development Engineer Seeks Post; specialist in ultra-high frequency and television technique.—Box 65, c/o *The Wireless World*. [8562]

ELECTRIC DRY SHAVERS

REMINGTON, Rand, Shavemaster, Packard, Casco and Rabado.—Trade enquiries to Leonard Higgs, 363, Henry St., Blackpool. [0633]



At the picnic, our portable set
Quite early, stopped working, and yet
We missed none of the fun
As we might well have done
If we hadn't had FLUXITE, you bet!

See that **FLUXITE** is always by you—in the house—garage—workshop—wherever speedy soldering is needed. Used for 30 years in Government works and by leading engineers and manufacturers. Of Ironmongers—in tins, 4d., 8d., 1/4 and 2/8. Ask to see the **FLUXITE SMALL-SPACE SOLDERING SET**—compact but substantial—Complete with full instructions, 7/6. Write for Free Book on the art of "SOFT" SOLDERING—and ask for leaflet on **CASE-HARDENING STEEL** and **TEMPERING TOOLS** with **FLUXITE**.

TO CYCLISTS! Your wheels will NOT keep round and true unless the spokes are tied with fine wire at the crossings AND SOLDERED. This makes a much stronger wheel. It's simple—with **FLUXITE**—but IMPORTANT

THE FLUXITE GUN

is always ready to put Fluxite on the soldering job instantly. A little pressure places the right quantity on the right spot and one charging lasts for ages. Price 1/6 or filled 2/6.



ALL MECHANICS WILL HAVE

FLUXITE

IT SIMPLIFIES ALL SOLDERING

FLUXITE, LTD., Dept. W.W., DRAGON WORKS, BERMONDSEY ST. S.E.1

Lockwood CABINETS

ACOUSTICALLY DESIGNED

A complete range for all Wireless World Receivers and Commercial Chassis

Special Drawings free on request

Send 1d. stamp for details of Standard Models

Lockwood & Co., 65, Lowlands Road, Harrow

Telephone: Byron 1818

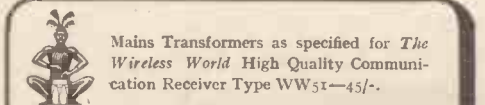

Mains Transformers as specified for *The Wireless World* High Quality Communication Receiver Type WW51-45/-.

W. BRYAN SAVAGE LTD.

Westmoreland Rd., London, N.W.9. Phone: Colindale 7131

THE BEST WAY TO LEARN MORSE

"MASTERS" INSTRUCTIONAL RECORDS Prepared by an ex-R.A.F. Signal Instructor, these records contain messages at a speed of from 2 to 20 words a minute. Details on request.

Price 2/6 each or Complete Set of Three 7/- C. E. MASTERS

Orchard House, Finchampstead Road, Wokingham, Berks.

M.R. SUPPLIES for Exclusive Modern Bargains

GREAT SUMMER CLEARANCE. Quantity definitely limited to numbers as stated—immediate reservation essential. Deposit secures.

7 ONLY
EDISWAN "TUNBAR" BATTERY CHARGERS, new. 200/250 v. A.C. 5 circuit, 60-cell model delivering 5-amps. up to 30 volts. Suitable for all battery charging, 2 volt to 19-volt. In steel cabinet with 0/5 Ammeter. (List £12/12/-). £5/10/- each. Also 3 only slightly soiled (new barreters and rectifiers), £4/15/- each.

5 ONLY
G.E.C. 1545 SCHOOL OR HOSPITAL RECEIVERS. Universal A.C./D.C. Superhet in fine oak cabinet 20 by 12 1/2 by 8 1/2 inches. Laboratory-built far above commercial standards with high-fidelity 6-watts output. Officially approved for School Broadcasting and ideal for all communal and domestic reception in Schools, Hospitals, Hotels, Clubs, Institutes and the Home. Multi-matched output for up to five speakers or 400 pairs 'phones. Station named dial, 200/2,000 metres. (List £24.) Brand new in makers' transport cases, £7/10/- each.

52 ONLY
ROTHERMEL DE LUKE PIEZO-CRYSTAL "TWEETERS". New 30/- senior model, handling 6-watts. Essential for high-fidelity reproduction, 19/6 each.

25 ONLY
ROTHERMEL PIEZO-CRYSTAL PICKUPS, 23/6. Also a limited number of the Rothermel de Luke Piezo-Crystal Pickups, undoubtedly the finest pickup obtainable, 37/6.

75 ONLY
PIEZO-CRYSTAL ELEMENTS offered at under one-half net cost of importation. 2 1/2-inch diameter, fitted stylus. For construction of Microphone, Pickup, Cardophone, Tweeter, etc. Rare opportunity, 6/11 each.

22 ONLY
G.E.C. GRAMOPHONE PICKUPS. Really fine response, light on records, large output. We have already sold over 700 to very satisfied users. Final opportunity, 6/6 each, complete with arm.

4 ONLY
G.E.C. "OVERSEAS 7" RECEIVERS. A.C. 100/250 v. tuning continuously from 11 to 855 metres in five bands. Built to rigid tropical specification and listed at £24. Built-in auditorium speaker with silencing key. Finest receiver for the s.w. enthusiast. Brand new £9/10/- each.

2 ONLY
"VELODYNE" VELOCITY BIRON MICROPHONES. Brand new 12-gns. model, mounted in tilting shroud. The ultimate in high-fidelity. Complete with appropriate transformer. £4/18/6 each.

18 ONLY
COLLAPSIBLE MICROPHONE STANDS. Best London chromium plated. Very rigid in use. 3-draw extending to 3 1/2 feet, collapsing to 16-inches. Usually 36/- With 1-inch screwed base mounting, 18/6. Or with 8 1/2-inch chromium suspension ring, 23/6.

11 ONLY
G.E.C. POWER PACKS (for A.C. Eliminator). Delivering 250 v. D.C., 35 m.a. and 4 v. 4 a., A.C. Ideal for Preliminary Amplifier, Radio Stage or Set, Field Excitation, etc. Sturdily made, in steel cabinet 8 by 8 by 5 1/2 inches, with Osram U10 rectifier. (Listed over £6.) To clear these last few, 22/- each.

21 ONLY
NEON TRANSFORMERS (Foster). Also suitable for cathode ray, etc. Oil-filled, 9,500 and 12,000 volts. Primary 200/250 v. Second-hand, perfect. Either 15/6 each.

7 ONLY
PORTABLE PLAYING DESK AMPLIFIER CABINETS. Fitted hinged motor-board. Strongly made, walnut finish, corners reinforced. Stay-hinges to lift-up lid. Panel opening 12 1/2 by 4 1/2 inches. Overall size 17 by 17 by 1 1/2 inches, fitted bronze locking lugs, removable gridded panel at rear and carrying handles. (Cost 35/-) Sketch on request, 15/6 each.

66 ONLY
G.E.C. 1576 MICROPHONE TRANSFORMERS for all Carbon Mikes. Fully shrouded 4 by 4 by 2 1/2 inches, with plug type terminals. (List 25/-) These excellent transformers for only 6/6 each.

11 ONLY
"CENTURY" 16TH H.P. 200/250 V. A.C. MOTORS. Repulsion-Inducted, 1,450 r.p.m. (very finest type). Cushion mounted. 8 H.P., perfect, 35/- Also ditto, brand new, 42/6. Also brand new "Century" D.C. one-half h.p. 200/250 v. 2,900 r.p.m., 8 only at 52/6 each. Also new 32 volt (private plant) D.C. 1,3rd h.p., 1750 r.p.m., 2 only at 39/6 each. Also new 1/8th h.p., split phase, 110 volts A.C., 1425 r.p.m., 32/6. Also D.C. 100/110 volts 1/4th h.p., 25/- All motors self-starting, standard shafts, and very silent running. All by best maker—"Century".

7 ONLY
"CENTURY" IGNITION MOTORS. Very special offer—brand new. D.C. 1/8th H.P. 1,460 r.p.m. 200/230 v. with slip rings delivering 100/120 volts 25 cycles, 110 watts. A useful form of rotary converter, listed at over £9 each. Offered at only 39/6 each.

Here's a bargain that has already pleased hundreds of customers. **INTERFERENCE SUPPRESSORS**, comprising a twin wave-form wound H.F. Choke and 1 x 1 m.f. 400 v. wkg. Condenser, with diagram. For very simple installation between radio set and mains. Definitely eliminates all interference introduced through the house mains. It does the trick. This unit is worth considerably more than 3/6, because it is the scientific solution to a large percentage of interference trouble.

EMBEDDED SPEAKERS 8in. M Coil with transformer, 2,000 and 10,000 ohms fields only, well-made, fine response, 8/6.

MINIATURE M/COIL UNITS, Perm. Magnet, only 3-inches diameter, 15-ohms imp. Ideal mike as they are. Perfect for Intercom, 9/11.

PANEL METERS, as supplied by us to Schools and Technical Colleges all over the country. A.C. D.C. spring controlled M.Iron. 2-inches dia., neat black finish. Amps., 0-1, 0-3, 0-5 and 0-10, any one 5/6. Volts, 0-10, 0-250, any one 6/11. WESTINGHOUSE M.COIL AMMETERS, 2 1/2-inch dia., panel mtg., 0/10 amps (deslunt to 90 m.a.), 7/11.

MORSE KEYS (Govt. pattern). Fine adjustable action with silver contacts, heavily plated on base 6 by 3 1/2 inches, 8/6.

G.E.C. PORTABLE PROJECTOR SPEAKERS, comprising 15-watt P.M. Unit on 50-inch folded horn contained in leatherette-covered cabinet, 18in. by 18in. by 1 1/2in., with handle. Last few at only 65/- each. TRUVOX 42-INCH PROJECTOR TRUMPETS, straight type with standard reinforced throat. All units fit New 45/- Other P.A. Horns and Units in stock.

SLOW MOTION CONDENSER DRIVES, Standard 4" socket and spindle, ratio 7:1. Very fine action, 1/- each.

Order any item with complete confidence of satisfaction.

M.R. SUPPLIES, 68, New Oxford Street, London, W.C.1. (Telephone MUSEum 2958)

THE INSTITUTE OF WIRELESS TECHNOLOGY (Founded in 1925. Incorporated).

PROFESSIONAL MEMBERSHIP
The advantages of professional membership are open to all qualified wireless engineers.

Full information, with syllabus, may be obtained from the Secretary, Institute of Wireless Technology, 4, Vernon Place, Southampton Row, London, W.C.1. Phone: Holborn 4879.

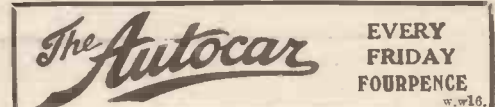

MISCELLANEOUS

CHEAP Printing.—1,000 billheads, 3/6; sample free.—Cretcway Press, 18, Buxted, Sussex. [8180]

G.P.O. Engineering Dept. (No experience required.) Commencing £3/13 per week. Age 18-23. Excellent prospects.—Free details of entrance examination from B.I.E.T. (Dept. 574), 17-19, Stratford Place, London, W.1. [8522]

TRACERS (both sexes) Required Urgently for Drawing Offices.—Those wishing to take up this lucrative work should apply immediately for Free Handbook to B.I.E.T. (Dept. 718), 17-19, Stratford Place, Oxford St., London, W.1. [8568]

EVERY Radio Dealer Who is Not a Regular Reader of "The Wireless and Electrical Trader" should send his trade card at once for a specimen copy and full details of the "Trader" Services. "The Wireless and Electrical Trader" has the widest influence, the largest weekly circulation, and is read by all the leading manufacturers and traders. Trade only, 15/- per annum, post free.—Published at Dorset House, Stamford St., London, S.E.1. [0615]

PATENTS

"**PRACTICAL** Hints on Patents," free on application.—The Imperial Patent Service, First Avenue House, High Holborn, W.C.1. Preliminary consultation free. [0481]

TUITION

RADIO Training.—P.M.G. exams, and I.E.E. Diploma; prospectus free.—Technical College, Hull. [0611]

PRACTICAL Radio and Television Home Study Courses; booklet free.—I.P.E., 3, Shirley Rd., London, W.4. [8506]

WIRELESS.—Complete training, Marine, Broadcast and Television. Posts waiting. Mod. fees. Boarders taken. Approved college, prosp.—Dept. W., London Radio College, Grove Park Rd., London, W.4. (Chi. 3244.) [0580]

BUSINESSES AND PROPERTY FOR SALE, TO BE LET, OR WANTED

OPPORTUNITY for Radio and Cycles; new shop adjoining recently developed estate in long established area; main road, S.E.12.; attractive terms.—Box 91, c/o The Wireless World. [8567]

"**THE** Wireless and Electrical Trader" is an essential part of the equipment of every Wireless Trader; its pages reflect the very latest turn of trade events, and it is read by all the leading dealers and manufacturers, for particulars of businesses offered or wanted. By subscription to the trade only, 15/- per annum, post free.—Send your trade card for specimen copy to Dorset House, Stamford St., London, S.E.1. [0614]

BOOKS, INSTRUCTION, ETC.

AMERICAN Valve Data.—The new 200-page Raytheon Valve Data Book gives full characteristics and applications of all types of American valves; invaluable to all servicemen; post free, 2/3; abroad, 3/-.—Leonard Heys, 36, Henry St., Blackpool. [0594]

"**THE** Wireless World" Diary for 1939 contains 77 pages of facts, formulae and general information of the kind that is always wanted but is difficult to follow. Also a list of the most important European Broadcasting Stations and short-wave stations of the world. Twelve pages of circuit diagrams of receivers, amplifiers and units.—By post 1/7 from Iliffe & Sons, Ltd., Dorset House, Stamford St., London, S.E.1.

"**FOUNDATIONS** of Wireless." By A. L. M. Sowerby, M.Sc. Second edition. An elementary textbook on receivers. Deals fully with the construction of wireless sets, valves, and the process of detection. Price 4/6 net. By post 4/11, from Iliffe and Sons, Ltd., Dorset House, Stamford Street, London, S.E.1.

"**RADIO** Data Charts." By R. T. Beatty, M.A., B.E., D.Sc. Second edition. A series of Abacs providing most of the essential data required in receiver design and enabling problems to be solved without having recourse to complicated mathematical formulae. Price 4/6 net. By post 4/10, from Iliffe and Sons, Ltd., Dorset House, Stamford St., London, S.E.1.

INDEX TO ADVERTISEMENTS

	PAGE
Anglo-American Radio (& Motors), Ltd.	2
Armstrong Manufacturing Co.	2
Automatic Coil Winder Co., Ltd. .. Inside Front Cover	
Belling & Lee, Ltd.	2
Birmingham Radiomart G5N1	1
British Institute of Engineering Technology	1
British Insulated Cables, Ltd.	1
British Mechanical Productions, Ltd.	1
British Thomson-Houston Co., Ltd., The	1
Capstan Cigarettes	5
Chloride Electrical Storage Co., Ltd.	5
Edison Swan Electric Co., Ltd.	4
Electradix Radios	4
Evrizone Radio & Television Co., Ltd.	5
Fluxite, Ltd.	5
General Electric Co., Ltd.	5

	PAGE
Gramphon Reproducers	5
Henley, W. T., Telegraph Works Co., Ltd.	5
Institute of Wireless Technology	5
International Correspondence Schools	5
Jackson Bros. (London), Ltd.	5
Lockwood & Co.	5
London Radio Supply Co.	5
Marconi-Ekco Instruments, Ltd.	5
Masters, C. E.	5
McCarthy, H., Ltd.	5
M.R. Supplies	5
Pamphonic Reproducers, Ltd.	4
Partridge, N.	4
Peto-Scott Co., Ltd.	1
Player's Cigarettes	1

	PAGE
Premier Supply Stores	5
Quartz Crystal Co.	5
Savage, W. Bryan, Ltd.	5
Sound Sales, Ltd. Inside Front Cover	
Summers, John, & Sons, Ltd.	1
Taylor Electrical Instruments, Ltd.	1
United Insulator Co., Ltd.	1
Universal Electric	1
Varley, Ltd.	1
V.G. Manufacturing Co.	1
Voigt Patents, Ltd.	1
Vortexion, Ltd.	1
Welburn Radio, Ltd.	1
Wharfedale Wireless	1



The book which will help you to get the best results with your camera!

Brighter Photography

by DAVID CHARLES, F.R.P.S.

This handy book reveals in a clear, attractive way the secrets of successful photography. Though primarily intended for the novice, it is invaluable to every keen camera user.

The carefully arranged chapters cover the whole field from the choosing of a camera to developing and printing the finished picture. Details of the various photographic materials on the market are given, and there are important sections dealing with Focusing, Aiming the Camera, Photographic Groups, Lighting and Exposing.

In addition there are over one hundred and sixty illustrations, each numbered and each conveying a really useful hint. By simple cross references these illustrations provide a series of clear, concise lessons in the art of making better pictures.

PRICE 2/6 net
By post 2/9

From all Leading Booksellers, or direct from the publishers

ILIFFE & SONS LTD., DORSET HOUSE, STAMFORD STREET, LONDON, S.E.1.

W.W.40

Printed in England for the Publishers, ILIFFE & SONS LTD., Dorset House, Stamford Street, London, S.E.1. by The Cornwall Press Ltd., Paris Garden, Stamford Street, London, S.E.1. "The Wireless World" can be obtained abroad from the following: FRANCE: W. H. Smith & Son, 248, Rue Rivoli, Paris; Hachette et Cie, Réaumur, Paris, and branches: Messageries Dawson, 4, Rue de Faubourg, Poissonniere, Paris. BELGIUM: W. H. Smith & Son, 74-75, Boulevard Adolphe Max, Brussels. AUSTRALIA: Gordon & Gotch, Ltd., Melbourne (Victoria), Sydney (N.S.W.), Brisbane (Queensland), Adelaide (S.A.), Perth (W.A.), and Launceston (Tasmania). NEW ZEALAND: Gordon & Gotch, Ltd., Wellington, Auckland, Christchurch and Dunedin. INDIA: A. H. Wheeler & Co., Bombay, Allahabad and Calcutta. CANADA: Imperial News Co., Toronto, Winnipeg and Vancouver; Benjamin News Co., Montreal; Gordon & Gotch, Ltd., Toronto. SOUTH AFRICA: Central News Agency, Ltd.; Wm. Dawson & Sons (S.A.), Ltd., Cape Town. UNITED STATES: The International News Co., New York.

Sixth Edition

Revised and Enlarged

HANDBOOK of TECHNICAL INSTRUCTION for WIRELESS TELEGRAPHISTS

by H. M. DOWSETT
(M.I.E.E., F.Inst.P., M.Inst.R.E.)

This standard handbook is planned primarily for the use of wireless operators, whether prospective or actual. It is virtually a complete theoretical course for students wishing to qualify for the Postmaster-General's Certificate of Proficiency.

CONTENTS INCLUDE:

The Electric Charge and the Condenser—The Condenser in Practice—Direct Current and Ohm's Law—Scalar and Vector Quantities and Curve Plotting—Primary Batteries—Accumulators—Magnetism—Electro Magnetism—Self-Induction—Dynamo Electric Machines—Measuring Instruments—Switchboards and Switchgear—Alternating Current Effects, and Vector Diagrams—Alternating Current Fundamental Formulae—Alternating Current Generators, Alternating Current Motors and Transformers—Damped Oscillations—Commercial Types of Spark Transmitter—Aerials and Radiation—Simple Receiver Circuit and Crystal Detector—Thermionics and the Various Applications of the Valve—Depth Sounding—Valve Transmitters—Wavemeter and Transmitter Adjustment—Theory of Valve Receiver Circuits—Valve Receivers—Short Wave Aerials and Apparatus—Marine Direction Finders—Marine Audio Relay Service—Distress Call Apparatus—Lifeboat and Emergency Outfits—Trawler Apparatus—Maintenance of Marine Radio Installations and Possible Faults.

NOW ON SALE PRICE 21/- By post 21/9
Foreign Postage 22/-.

Obtainable from leading booksellers or direct from the Publishers.

ILIFFE & SONS LTD., DORSET HOUSE, STAMFORD STREET, LONDON, S.E.1

The ELECTRICAL REVIEW

The Complete Technical Journal

Practical articles on all aspects of electricity supply and utilisation—industrial, commercial and domestic. Latest news of the electrical industry and developments. Advertisement pages form a comprehensive buyers' guide.

Contents of June 16th Issue:—

RADIO MANUFACTURE

An account of a visit to E. K. Cole's works at Southend.

ELECTRICAL MANAGEMENT

An engineer's views upon the necessary qualifications for running an electricity supply concern.

OPAL GLASS

Recent research and achievements in diffusing glassware for lighting purposes.

DRY TYPE HEAT STORAGE

The use of magnetite for the generation and storage of heat.

THE WEEK'S NEWS

EVERY FRIDAY 6d. Subscriptions: United Kingdom £1 14s.
Canada £1 12s. Other Countries
£2 1s 6d per annum, post free.

ELECTRICAL REVIEW LTD.

Dorset House, Stamford Street, London, S.E.1

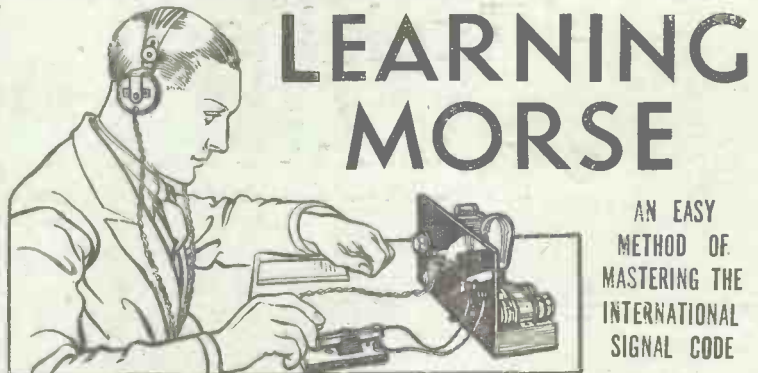

LEARNING MORSE

AN EASY
METHOD OF
MASTERING THE
INTERNATIONAL
SIGNAL CODE

Published from
the Offices of

The **Wireless World** 6^D NET

ILIFFE & SONS LTD., Dorset House, Stamford St., London, S.E.1

BY POST 7d.
W.W.24

THE WIRELESS ENGINEER

The Journal for Professional Engineers
and Advanced Wireless Experimenters

Monthly

2/6 net.

Annual Subscription

32/- post free.

ILIFFE & SONS LTD., Dorset House, Stamford St., London, S.E.1

Mention of "The Wireless World," when writing to advertisers, will ensure prompt attention.

W.W.24

DAILY SKETCH

FOR INSIDE INFORMATION

- Explains the News
- Anticipates the News
- Makes Clear the Tangled Web of the News

Every Day more People buy the
Daily Sketch to

BE "IN THE KNOW"

The

6^D

Wireless World

**THE
PRACTICAL
RADIO & TELEVISION JOURNAL**

Thursday, June 22nd, 1939



**THE NEW
MAURETANIA'S
WIRELESS**

VALVE VOLTMETERS OF ALL TYPES.



Miniature Valve Voltmeter Type 105X

A simple, inexpensive, accurate Valve Voltmeter, completely self-contained, operating from a 3-volt torch battery fitted within its case.

A highly sensitive microammeter is used in conjunction with a diode rectifier, the diode making the circuit substantially independent of valve characteristics, and permitting valve replacement without disturbing the calibration.

The battery voltage is kept constant by means of a rheostat and a voltage range selector switch is provided.

Of robust construction, this instrument is ideal for general test purposes on Radio, Audio or Power frequencies in the Laboratory, Test Room or Workshop, wherever voltage, measurement with negligible current consumption is essential.

SPECIFICATION

VOLTAGE RANGES

Three Ranges : 0/5v, 0/25v and 0/100v.

FREQUENCY RANGE

20 cycles/p.s. to 10 megacycles/p.s.

ACCURACY

5v. Range $\pm 3\%$. 25v. and 100v. Range $\pm 2\%$.

INPUT IMPEDANCE

100v. Range, $\frac{1}{2}$ megohm. 25v. Range, $\frac{1}{2}$ megohm.
5v. Range, 50,000 ohms.

INPUT CAPACITANCE. 15 $\mu\mu$ l.

DIMENSIONS. 7 $\frac{1}{2}$ " x 5 $\frac{1}{2}$ " x 4 $\frac{1}{2}$ "

NETT WEIGHT. 4 lbs. 12 oz.

FINISH. Grey Enamel.

PRICE—£12 - 2 - 0.

Acorn Triode H.F. Valve Voltmeter Type 106X

An instrument for precision measurement of low voltages at very high frequencies.

The Acorn Valve Voltmeter is of the Anode Bend type. The valve, a G.E.C. acorn pentode connected as a triode and the by-pass condensers, are built into a brass head piece, which is on the end of a self-supporting flexible metal tube, so that the valve can be brought within one or two inches of the point at which voltage is to be measured. The input impedance is very high being due only to valve losses. The input capacitance is approximately 3.5 $\mu\mu$ f. It is calibrated in R.M.S. values for sinusoidal wave form. Since the electrode clearances are very small the electron transit time is low compared with any frequencies up to 50 megacycles/sec., thus the damping imposed by use of a valve of this type is very small compared with the conventional type of valve, the impedance of which may go down as low as 10,000 ohms at 50 megacycles/sec.

SPECIFICATION :

VOLTAGE RANGES. Three ranges : 0-1v, 0-3v, and 0-15v.

FREQUENCY RANGE. 20 cycles/sec. to 50 megacycles/sec.

ACCURACY. $\pm 2\%$ of full scale deflection on each range: Calibration to $\pm 1\%$ at 800 p.p.s.

INPUT IMPEDANCE. Approx. 700,000 ohms at 50 megacycles/sec., due only to valve losses.

INPUT CAPACITANCE. Approx. 3.5 $\mu\mu$ F. with head ; 3.0 $\mu\mu$ F. without head.

POWER SUPPLY. 4v. 1a. Accumulator connected externally. 90v. H.T. Battery housed in case. (Supplied with contact.)

DIMENSIONS. 14" x 7 $\frac{1}{2}$ " x 7" overall, excluding valve head and tube.

NETT WEIGHT. 18 $\frac{1}{2}$ lbs. including H.T. Battery.

FINISH. Grey Enamel

We shall be pleased to send full details of these instruments and other Voltmeters for use up to the highest radio frequencies and also details of other H.F. measuring apparatus, on receipt of details of your requirements.



PRICE—£32 - 9 - 0.

SALFORD ELECTRICAL INSTRUMENTS LTD.

PEEL WORKS, SALFORD, 3.

Telephone: PLackfriars 8888 (3 lines)

Telegrams and Cable: "SPARKLESS, MANCHESTER"

PROPRIETORS: THE GENERAL ELECTRIC Co. Ltd., OF ENGLAND

Mention of "The Wireless World," when writing to advertisers, will ensure prompt attention.

The Wireless World

THE
PRACTICAL RADIO
JOURNAL
29th Year of Publication

No. 1034.

THURSDAY, JUNE 22ND, 1939.

VOL. XLIV. No. 25.

Proprietors : ILIFFE & SONS LTD.

Editor :
HUGH S. POCOCK.

Editorial,
Advertising and Publishing Offices :
DORSET HOUSE, STAMFORD STREET,
LONDON, S.E.1.

Telephone : Waterloo 3333 (50 lines).
Telegrams : "Ethaworld, Sedist, London."

COVENTRY : 8-10, Corporation Street.
Telegrams : "Autocar, Coventry." Telephone : 5210 Coventry.

BIRMINGHAM :
Guildhall Buildings, Navigation Street, 2.
Telegrams : "Autopress, Birmingham." Telephone : 2971 Midland (5 lines).

MANCHESTER : 260, Deansgate, 3.
Telegrams : "Iliffe, Manchester." Telephone : Blackfriars 4412 (4 lines).

GLASGOW : 26B, Renfield Street, C.2.
Telegrams : "Iliffe, Glasgow." Telephone : Central 4857.

PUBLISHED WEEKLY. ENTERED AS SECOND
CLASS MATTER AT NEW YORK, N.Y.

Subscription Rates :
Home and Canada, £1 10s. 4d. ; other
countries, £1 12s. 6d. per annum.

As many of the circuits and apparatus described in these
pages are covered by patents, readers are advised, before
making use of them, to satisfy themselves that they would
not be infringing patents.

CONTENTS

	Page
Editorial Comment	571
Distortion in Transformer Cores. I.—Oscillograms and What They Reveal	572
Vertical or Inverted "L" Aerials (Concluded)	575
Wireless on the "Mauretania" ..	578
Problem Corner	580
Adding a Beat Frequency Oscillator	581
Letters to the Editor	582
News of the Week	583
Facsimile—What it is and how it Works	585
Television Programmes	586
Precipitation Static	587
Five-metre DX	589
Unbiased	590
Random Radiations	591
Recent Inventions	592

EDITORIAL COMMENT

Improving Quality Frequency Response versus Harmonic Distortion

THE heresy hunters have been giving "straight-line" amplification a rough handling lately. It has been assailed on the ground that it is neither necessary nor even desirable in many circumstances, but chiefly, we think, because it has in the past monopolised more than its fair share of the limelight, which should have from the first been directed equally on the question of harmonic distortion.

It is easy to understand how this came about. The apparatus required for the measurement of harmonic content is much more expensive than that required for plotting frequency response, and the time taken to analyse the total harmonic into its components in order that they may be assigned their relative "annoyance value" is considerable. Further, the degree of harmonic distortion may vary with frequency, and determinations must be made at several different parts of the scale.

Few manufacturers have been in a position to give more than the frequency response of their transformers, loud speakers, etc., and the publication of this information by itself has not unnaturally led the buying public to regard it as the criterion by which a piece of audio-frequency apparatus may be judged. As a result, "straight line" response has acquired the status of a demand which the manufacturer cannot afford to ignore.

Therein lies a very real danger. Take the case of an output transformer. It is much easier to sustain the response to very high frequencies if

the physical dimensions of the winding, and hence the core, are kept small; but this may result in serious distortion through working it at too high a flux density. Thus in order to sustain the "goodly" shape of the frequency characteristic a designer may be forced literally to insert a "rotten core." Incidentally, this distortion in transformer cores has not received the attention it deserves, and we would particularly commend the series of articles on that subject beginning in this issue to the attention of quality enthusiasts, professional as well as amateur.

The improvement which has been effected in the quality of sound from the London television station is due largely to the reduction of harmonic distortion in the audio-frequency equipment, and all who have listened to the reproduction through a good amplifier and loud speaker will appreciate the subtle difference from older stations in which a higher harmonic content is tolerated. This has been achieved without sacrificing either the range or flatness of the frequency response, which shows that there is no irreconcilable antagonism between frequency response and harmonic distortion, at least on the transmitting side.

At the receiver the frequency response may have to be modified to suit room characteristics, but harmonic distortion will always have to be kept low. It is here that much leeway remains to be recovered, and now that control of frequency response has been reduced more or less to a matter of routine, we hope that designers will show as much diligence in seeking out and ventilating the breeding places of harmonic distortion.

In this way we may recover the balanced performance which is the foundation of all good quality.

Distortion in Transformer Cores

Part I.—OSCILLOGRAMS AND WHAT THEY REVEAL

By N. PARTRIDGE, B.Sc. (Eng.) A.M.I.E.E.

THERE are two distinct types of distortion in audio-frequency apparatus, (1) frequency distortion and (2) harmonic or amplitude distortion. To achieve ultra-high-quality reproduction it is necessary to study and eliminate both. Obviously, it would be useless to construct an amplifier having a perfect frequency characteristic if it produced, say, 10 per cent. harmonic dis-

tortion normally occurs in an output transformer? A little reflection will bring home the fact that such figures are never called

THIS is the first of a series of articles in which the question of amplitude distortion arising in the iron core of a transformer will be dealt with on a quantitative basis. Information on this subject is scarce and the design data given is the outcome of original research by the author.

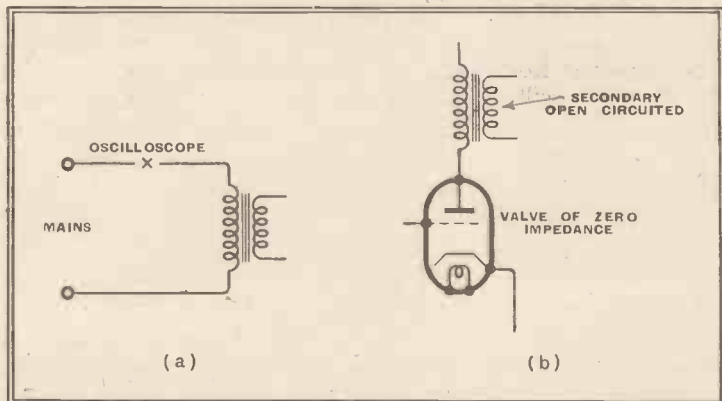

Fig. 1.—At (a) is shown an easy method of observing distortion of the current flowing in the primary of a transformer, while (b) indicates the equivalent valve circuit.

ortion at normal volume! Yet, strange as it is, this very one-sided treatment seems to be accepted as adequate when referring to output transformers.

That iron introduces harmonic distortion has been known for a very long time. Text-books and periodicals, not omitting *The Wireless World*, make frequent, if

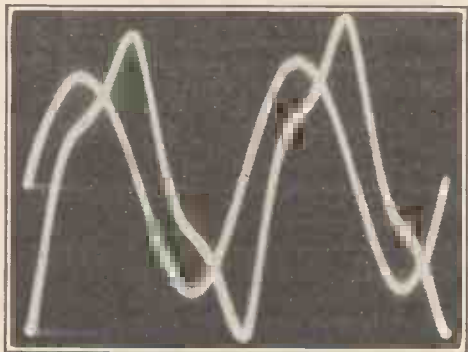

Fig. 2.—A typical oscillogram obtained from the arrangement of Fig. 1 (a).

obscure, references to it. "The core must be operated at a low flux density"; "a large core should be employed," etc., are typical observations. But how low must be the flux density and how big the core? Above all, what percentage harmonic dis-

into question. Harmonic distortion has been completely overshadowed by considerations of frequency response.

The simplest way of making the acquaintance of iron distortion is to connect the primary of an output transformer across the 230 v. 50 c/s mains with an oscilloscope in series with it as in Fig. 1 (a). A typical oscillogram is reproduced in Fig. 2.

The sine wave represents the mains voltage applied to the transformer, and the distorted curve represents the current flowing through it. The latter lags behind the voltage, as would be expected with an inductive load, and is badly out of shape. True, the circuit is not the equivalent of that in which output transformers are usually employed. First, the secondary is not loaded, and, secondly, the mains must be regarded as having zero impedance. Fig. 1(b) indicates the corresponding valve circuit. But although the arrangement is not representative of the usual conditions of operation, it will be seen later that it provides a key to all cases. The next step, therefore, is to put our somewhat haphazard experiment upon a more scientific footing.

There is a well-known formula which runs as follows:—

$$B = \frac{\text{Volts} \times 10^8}{4.44 \times \text{Frequency} \times \text{Core area} \times \text{Turns}} \dots (1)$$

Fig. 3.—A series of oscillograms illustrating how current distortion varies with flux density. "B" is the value of the peak flux density. The core material was Silcor 2.

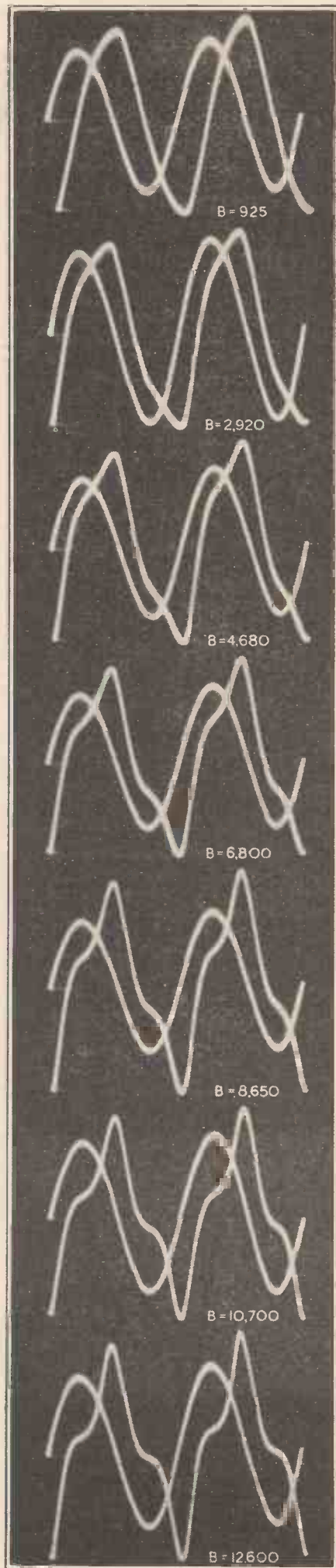

Distortion in Transformer Cores—

"B" is the peak value of the flux density reached in the core during a complete cycle. All the constants on the right-hand side of the equation are easily determined. The volts will be 230 or whatever the mains voltage happened to be when the photograph in Fig. 2 was taken, the frequency 50 c/s, the core area (in sq. cms.) can be measured and the turns upon the primary of the transformer can be counted. Thus the peak flux density is readily deduced and our photo is at once elevated from a typical example of distortion to a specific instance of distortion at a known flux density.

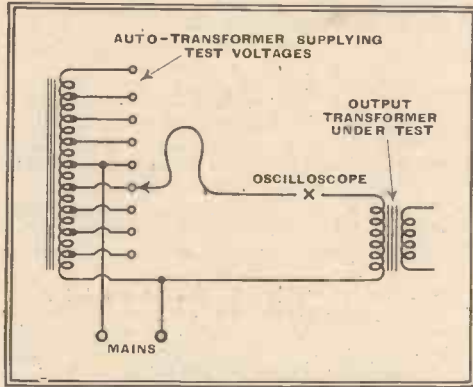

Fig. 4.—A modification of the circuit in Fig 1 (a) which allows observations of distortion at various known flux densities.

An extension of this idea can be added by turning formula (1) round the other way, thus:—

$$\text{Volts} = \frac{4.44 \times B \times \text{Frequency} \times \text{Core area} \times \text{Turns}}{10^8} \quad (2)$$

By selecting a number of values of "B" for which we should like distortion curves, the required test voltages can be calculated. An auto-transformer will serve to step the mains voltage up or down as necessary and enable us to produce a range of current oscillograms showing how the distortion varies with different flux densities. Fig. 4 outlines the circuit suggested. It is very important to note that a transformer *must* be used for regulating the test voltage. If a series resistance or potentiometer were employed it would act as a series impedance and render the results inconsistent.

Working on these lines, the oscillograms reproduced in Fig. 3 were obtained. The sine curves, in phase with the voltage, were taken for calibration purposes, and can be

Fig. 5.—The graph obtained by analysing the oscillograms of Fig. 4. The harmonics are expressed as a percentage of the fundamental. This is a very important series of curves and forms the basis of transformer distortion calculations.

ignored by the reader; the distorted current curves are all that matter for the moment. The maximum flux density is marked on each photograph. The particular material used for the core of the transformer was Silcor 2, supplied by Messrs. Magnetic and Electrical Alloys, Ltd., of Wembley. This grade of iron is commonly employed for speech transformers, and can be taken as representative of general practice. Obviously, different grades of iron are likely to produce different degrees of distortion. This aspect of the problem will receive full attention later.

With a modicum of mathematical knowledge and unlimited patience one can analyse the curves of Fig. 3 and produce a graph showing the magnitude of the various harmonics at all flux densities. Fig. 5 gives the result of this labour, and, as will be seen in due course, is a highly important addition to our knowledge of the characteristics of magnetic materials.

The harmonics are expressed as a percentage of the fundamental—i.e., of the true 50 c/s current. Only odd harmonics are present, as would be expected from the symmetrical nature of the oscillograms. Even harmonics result in an unsymmetrical wave shape. The analysis was in all cases extended to the eleventh harmonic, but only the third, fifth, and seventh were found to be of importance.

The meaning of Fig. 5 must be thoroughly understood before proceeding. It shows the harmonics, expressed as a percentage of the fundamental, present in the current flowing through an unloaded transformer when the said transformer is connected across a low-impedance source of such voltage and periodicity as to produce the corresponding flux density. The figures give no direct indication of the distortion the transformer would produce in normal use, but rather represent a characteristic of the core material. We

have to find out how these figures may be used as a basis for calculating the performance of the transformer in any specified circuit.

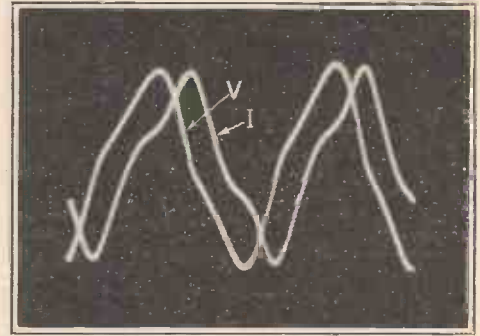
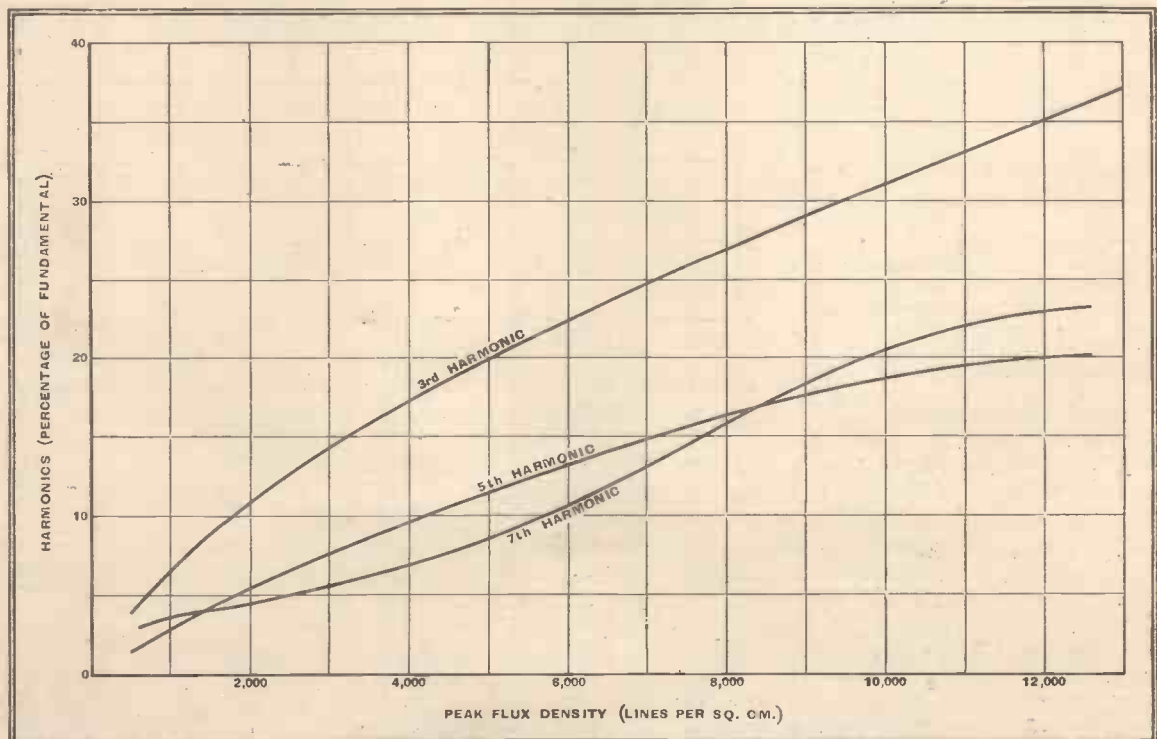

Fig. 6.—Showing how a medium impedance in series with the transformer causes both current and voltage to be distorted.

Increasing the impedance of the AC source—i.e., the mains supply—would bring conditions more nearly into line with those found in practice. Normally, a valve can have an AC impedance of anything from a fraction up to many times that of the transformer primary. The former case occurs when a low-impedance triode is used, and the latter when high-impedance tetrodes or pentodes are employed.

Fig. 6 shows the effect of introducing an impedance of approximately equal value in series with the transformer primary. The flux density was, in this instance, approximately 7,000 lines per sq. cm., and the photograph may be compared with the corresponding oscillogram in Fig. 3. Note that both voltage and current have become distorted. This is to be expected, because the transformer draws a distorted current, and therefore the voltage drop across the series impedance must of necessity be distorted. Hence the voltage across the transformer, which is the mains voltage minus the distorted drop across



Distortion in Transformer Cores— the series impedance, must also be distorted.

Evidently an extreme case could be arrived at by making the series impedance

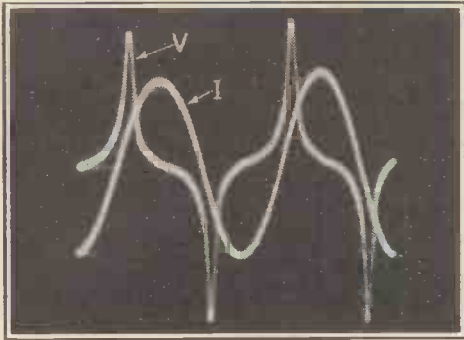
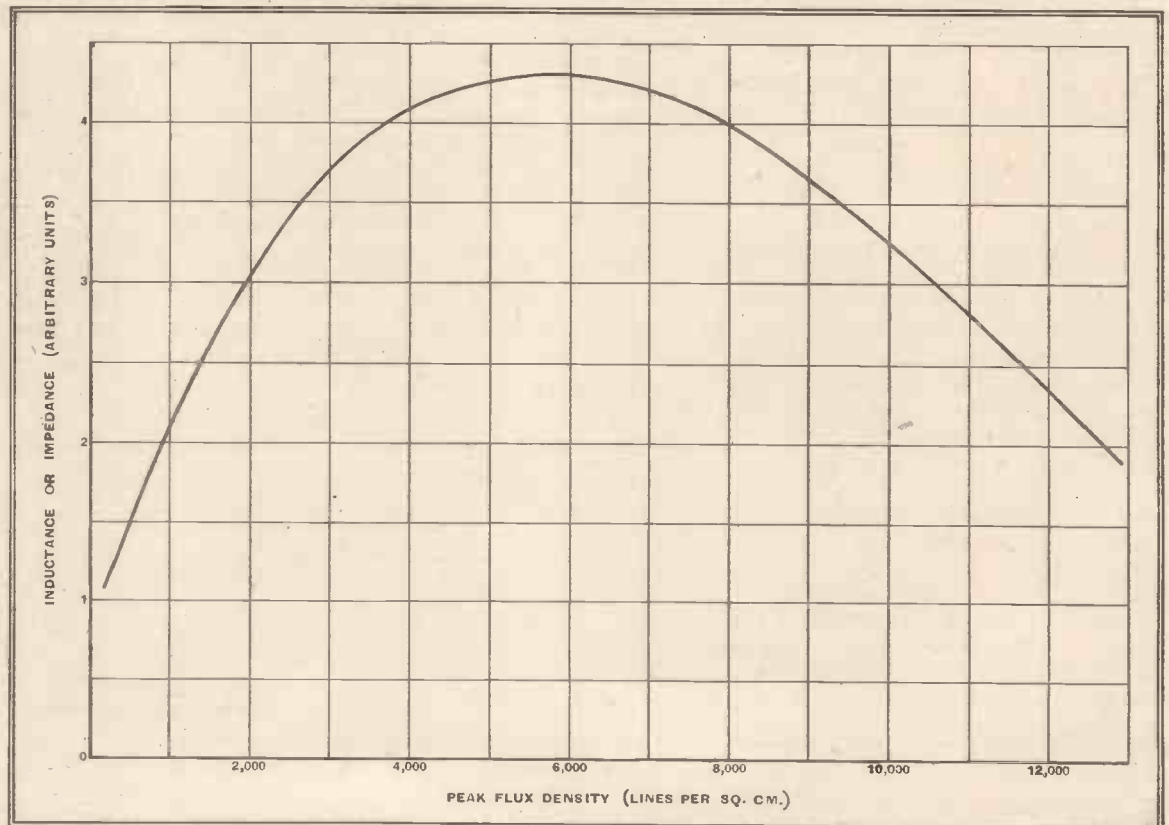

Fig. 7.—A very high impedance in series with the transformer results in distortion of the voltage, but gives a pure sine wave current.

very high compared with that of the transformer. Fig. 7 shows what happens under these circumstances. The current becomes a pure sine wave, and the distortion is transferred to the voltage curve. The flux density during this experiment was again maintained at a value of about 7,000 lines per sq. cm. (See Appendix.)

To sum up, at one extreme, where the impedance of the AC source is zero, the current is distorted while the voltage remains a pure sine curve. At the other extreme, where the source has a high relative impedance, the reverse is true—i.e., the voltage is distorted and the current a pure sine wave. Clearly, the relative impedance of the transformer compared with that of its associated valve is of considerable importance. A valve impedance is reasonably constant and can be estimated from figures supplied by the manufacturers. But the impedance of a transformer, even at a fixed frequency, is anything but

Fig. 8.—Illustrating how the inductance (or impedance) of a transformer, with a closed iron circuit of Silcor 2, varies with flux density. The inductance scale is arbitrary.



constant, and we must look into this question more closely.

A good many years ago it was the custom of certain manufacturers, and, I believe, of *The Wireless World* as well, to state the inductance of chokes and transformers when tested at a specified alternating terminal voltage. This was a very excellent idea, but it has died out, and only the inductance figure is mentioned nowadays. One tends to imagine the inductance of an output transformer as a fixed and constant thing, rather like

the resistance of a piece of wire or the capacity of a condenser. Actually, it is entirely dependent upon the test voltage, or, what comes to the same thing, the flux density. A test taken at around 5,000 lines per sq. cm. will give an inductance value perhaps three times as great as that measured at 100 lines per sq. cm.

Impedance Calculations

Definite figures can readily be obtained by replacing the oscillograph shown in the circuit of Fig. 4 by an ammeter. We have already seen how to work out the flux densities corresponding to the severalappings on the auto transformer by using formula (1). The voltage divided by the current will reveal the impedance at each density. The graph of Fig. 8 shows the values obtained plotted against "B."

It is true that impedance is equal to the voltage divided by the current, but in view of the distorted shape of the current wave form we ought to think carefully how it should be measured. The true impedance to 50 c/s will be the voltage divided by the 50 c/s fundamental of the current. The sine curves in Fig. 3 were taken with a known current, so that the analysis of the dis-

of the transformer and upon the number of turns on the primary winding. But whatever the design may be, the impedance or inductance will vary in the same manner as the flux density is changed, providing the transformer has a closed iron circuit of the same magnetic material—i.e., Silcor 2. By taking a single test at any known flux density, the inductance at any other density can be obtained by reference to Fig. 8.

In Part II it will be shown how the information expressed in the graphs of Fig. 5 and Fig. 8 can be used to calculate the distortion produced by any push-pull transformer (providing it has a closed magnetic circuit of Silcor 2) when used in any specified circuit.

APPENDIX

An analysis of the wave form illustrated in Fig. 7 gave 58 per cent. third harmonic, 34 per cent. fifth harmonic, and 39 per cent. seventh harmonic. These figures are very much higher than the corresponding percentages present in the distorted current curves (see Fig. 3 and Fig. 5). This is reasonable, because if the distorted current can be represented by:—

$$I = A_1 \sin(\theta + \beta_1) + A_3 \sin(3\theta + \beta_3) + A_5 \sin(5\theta + \beta_5), \text{ etc.},$$

one would expect distortion of approximately the same order in the distorted flux curve when a sine wave current is passed through the coil.

torted curves could be converted into actual current values. It was found that the impedances obtained by using the 50 c/s fundamental taken from the oscillograms were practically identical with those given when the distorted current was measured with a rectifier-type meter. This class of instrument gives a reading proportional to the mean current.

Returning to Fig. 8, the scale of impedance or inductance is an arbitrary one. The specific values in any particular case will depend upon the size of the core

But the induced voltage is proportional to the rate of change of flux—i.e., $\frac{d\phi}{dt}$, and the process of differentiation changes the ratio of the constants to $A_1, 3A_3, 5A_5$, etc., thus accentuating the harmonics.

No such simple relationship is found in practice. When the flux is distorted the iron losses increase, owing to the presence of third, fifth, and seventh harmonic eddy currents, etc. These losses may be represented as resistive loads across the primary of the transformer tending to reduce the apparent voltage distortion. Hence the accentuation of the higher harmonics in the voltage wave form is not so great as might be expected.

Vertical or Inverted "L" Aerials

THEIR MERITS FOR RECEPTION COMPARED

By F. R. W. STRAFFORD

(Concluded from page 55 of last week's issue)

AN aerial is a means for obtaining an alternating electric current from an electro-magnetic wave, and may consist of anything from a few feet of wire carelessly draped round a room to an elaborate structure as used in the commercial short-wave stations.

In the very early days of broadcasting it was nothing to possess a pair of 60ft. masts with a twin roof-spaced inverted "L" or "T" aerial of some 100ft. span. Anything smaller was regarded as inefficient. In these days the most ambitious outdoor aerial would have been regarded as useless when judged by those early standards.

The general "decadence" of the aerial system of to-day has been due largely to two causes. First, the increased sensitivity of receivers in general has rendered moderate reception possible in many cases on a few feet of indoor aerial, and, secondly, now that radio is a commonplace "across the counter" trade, manufacturers and dealers in their fierce price competition are not risking the loss of a prospective sale by adding a few pounds for an efficient and attractive aerial system.

This article, however, has been written for the listener who has sufficient technical experience to appreciate that, while reception is possible on a few feet of aerial, it is usually limited to a few high-powered and local stations on account of the general level of man-made interference radiated from the house wiring, etc.

Naturally, the colossal aerial systems of

the early days of crystal receivers are neither necessary nor desirable, but it can be proved that a high aerial using as little wire as possible, i.e., a vertical aerial, is the best arrangement for consistent and efficient reception.

For example, an inverted "L" aerial of 25ft. height, with a 25ft. horizontal portion, is not as desirable as a single vertical wire 50ft. in height, although the same length of wire is used in both cases. Before discussing the theoretical reasons underlying this statement let us consider the possibilities of erecting either of the aerials referred to. The average semi-detached two-storey dwelling house has

THE first part of this article dealt solely with the generation and properties of the electro-magnetic wave which constitutes the means for radio communication. In this article its interaction with the receiving aerial is considered.

dimensions approximately as follows:—Height from ground to eaves, 20ft.; height from ground to top of chimney stack, 35ft.

When a listener decides to erect a fairly good outdoor aerial he usually purchases a 20 to 25ft. pole to support the remote end of the aerial. Masts taller than 25ft. are usually disproportionately expensive and difficult to erect, particularly in confined spaces. With this major expense in mind the listener usually does not go to the further expense of attaching the other end of the aerial to his chimney stack, since it involves the hiring of ladders and often a builder's jobber to scale the roof and do the necessary work. Hence this end of the aerial is usually attached to the gutter boarding at about 20ft. above ground level, a point which may usually be reached by a little precarious balancing on bedroom window sills. In practice, therefore, the average good outdoor aerial may be regarded as having a mean height of 25ft.

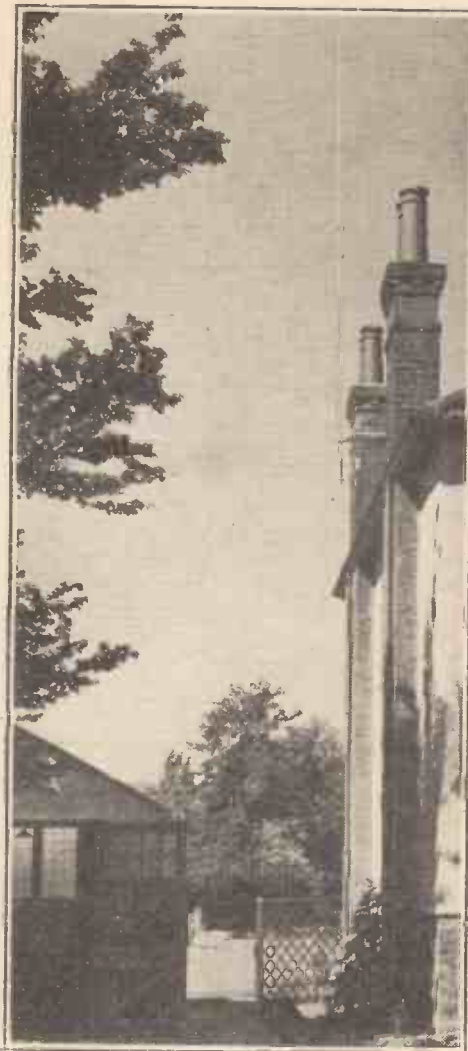

Now consider a vertical aerial which may conveniently comprise a vertical metal rod of, say, 10ft. in length attached by some insulating means to a 12ft. mast suitably lashed to the chimney stack itself. Allowing 2ft. overlap for the mast to the chimney stack, and 1ft. for the vertical metal rod to the mast, the total height of this arrangement above the top of the chimney stack will be 19ft. Adding this to the average height of the stack above the ground, this works out to a total height of 54ft., rather more than twice that of the inverted "L" aerial previously described.

Effective Height

It must be remembered that in the vertical system it is not only the 10ft. rod which comprises the aerial, but the length added by the down-lead must be added to this figure.

The effect of a vertically polarised wave upon an aerial is to create an EMF in all those parts of the aerial which are vertically disposed or may be resolved into their effective vertical components. Fig. 2 should make this quite clear.

The electro-magnetic wave emanating

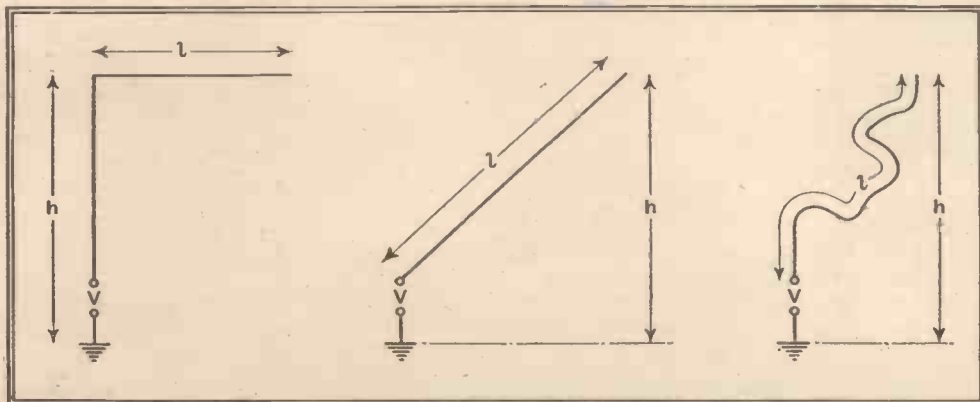

Fig. 2.—The effects of various shaped aerials in a vertically polarised electro-magnetic field. In all the above cases the voltage V is proportional only to h and not to l .

Vertical or Inverted "L" Aerials—

from a broadcast transmitter may arrive at the receiving aerial by two paths. First, there is what is known as the direct wave which travels over the surface of the earth. This wave is vertically polarised and its departure from verticality due to the imperfect conductivity of the earth as described in the first part of this article is not

Generally speaking, therefore, the aim of the listener should be to dispense as much as possible with the horizontal portion of his aerial, and provide greater vertical height. In this manner the aerial will be responsive mainly to the vertically polarised direct wave, and fading will be much less noticeable.

Although the horizontal portion of an

aerial is very much the same whether disposed horizontally or vertically. Hence there must be a net gain of signal strength at least proportional to the increase in height above 25ft.

In addition, the anti-fading characteristics are markedly better, particularly in the case of local-station fading where the sky wave is reflected earthwards almost vertically.

A further point to remember is this. Theoretically the field strength of a vertically polarised wave is uniformly distributed close to the earth's surface. In other words, theoretically the voltage developed in a roft. vertical wire is half that produced in a 20ft. wire, and so on. In actual practice the presence of surrounding conducting objects introduces a departure from this condition, and the higher elements of length are usually more effective than the lower parts. In densely populated areas, therefore, there should be many cases in which even greater advantages will accrue from the use of the high vertical aerial as compared with the average 25ft. high inverted "L."

Signal-to-Noise Ratio

Even when such vertical aerials are erected without the provision of anti-interference performance (i.e., transformers and screened down-lead) it must be remembered that interfering fields are usually located below the roof level of the building, hence the additional height above the roof, while increasing the signal strength markedly, does not materially increase the interference level. This fact, added to that of the partial demodulation of the weaker interference by the stronger signal at the detector, gives an unexpected increase in general signal-to-noise ratio over the inverted "L" in most cases. Also it must not be forgotten that the greater superficial area occupied by the plane of an inverted "L" aerial invites the pick-up of additional interfering fields emanat-

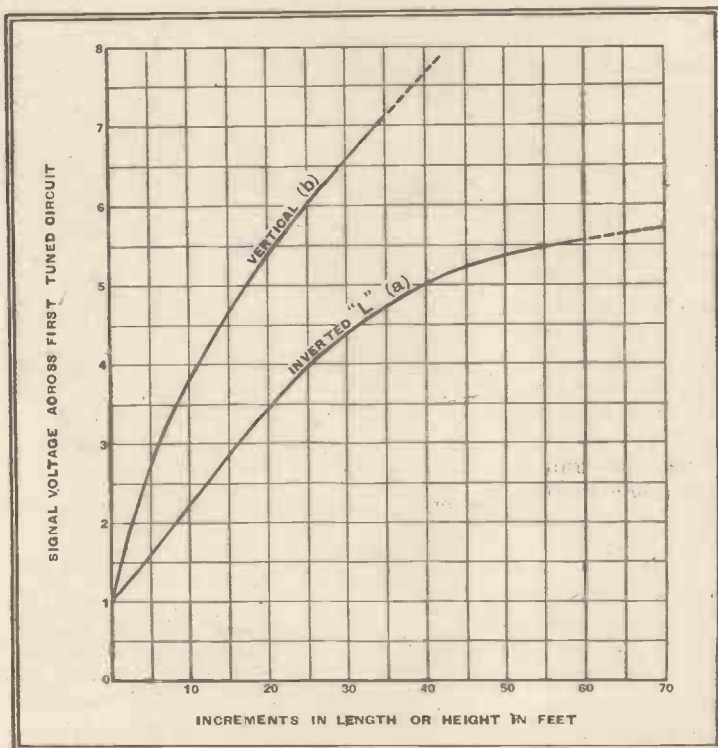

Fig. 3.—Signal voltage developed at 877 kc/s for various incremental aerial lengths over 25 feet. Vertical polarisation of the field existed for these measurements. The slope of the curves depends also upon the receiver input impedance, but the above are typical.

very great. These direct waves are of great importance since the service is based upon the fact that their properties do not vary during the course of the day.

The waves which arrive by the second path are those reflected from the upper electrified atmosphere, more properly termed the ionosphere, and these waves are often referred to as "sky waves." The strength of these waves depends upon the reflecting condition of the ionosphere, which is subject to seasonal, daily, hourly and even momentary variations of considerable magnitude. These waves account for the general increase in medium-wave signal strength at night time, and all the fading and distortion effects which every listener must have observed.

Minimising Fading

Broadcasting transmitter aerials are gradually reverting to types (notably vertical radiator masts) which transmit as little energy as possible at high angles, thereby minimising the production of sky waves.

The sky wave is subject to severe changes in polarisation during the process of reflection, and it can be shown that, in general, the horizontal portion of the receiving aerial is mostly responsible for the resultant fluctuation of signal EMF.

portion of an inverted "L" aerial, Fig. 4 (a), whose vertical down-lead is fixed at 25ft. in length. Curve (b) shows what happens when the increments of length are now disposed vertically as shown diagrammatically in Fig. 4 (b). It is at once apparent from the earlier paragraph that our average 25ft. high inverted "L" aerial will require a horizontal wire of at least 50ft. to provide the same signal input as a vertical aerial whose tip is 45ft. from the ground. With our average of 54ft. for the vertical type of aerial described the available signal is even greater.

The reason for the rapidly increasing signal strength as a result of extending the increments in the vertical direction is that the EMF generated in the aerial is increasing proportionately with the height, and that the capacity of the

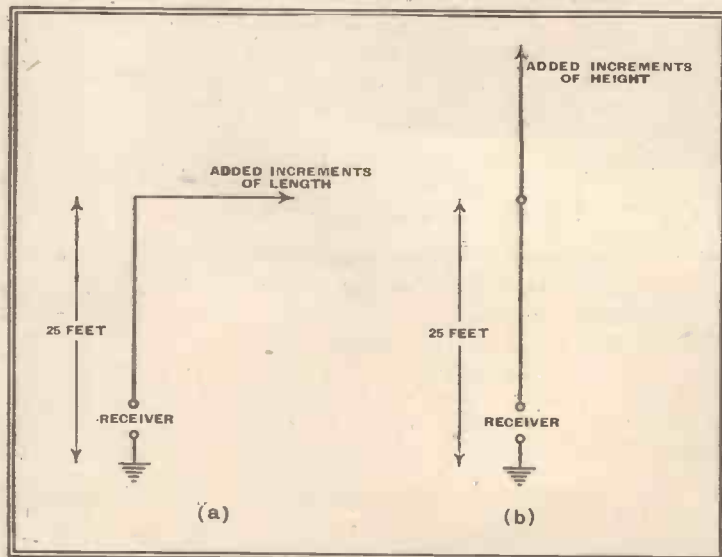

Fig. 4.—Diagram illustrating the method of adding incremental length for the curves of Fig. 3.

ing from points nearer its horizontal extremity—a condition which is entirely absent in the case of the vertical system.

Vertical or Inverted "L" Aerials—

A vertical aerial as previously described and recommended is admirably suitable for conversion into an anti-interference aerial. The reader is probably acquainted quite fully with such devices and the manner in which they perform, but it is thought that a little repetition will not be amiss.

The reason why an aerial may be made to reduce substantially the effect of interfering fields from electrical appliances lies in the different properties of the interference and signal fields respectively.

If the location of an aerial is moved a few yards the signal intensity will suffer a negligible change. This is obvious because if the transmitter is 10 miles distant and the aerial is moved 10 yards, either towards or from the transmitter, the theoretical change in signal strength will be related directly to the percentage change in distance which in the above case is only about 0.05 per cent.

On the other hand, the interfering fields which are usually confined to within a short distance from the aerial will, by removal of the aerial of a few yards, fall off rapidly in intensity since the percentage change in distance is great.

Summed up in a few words, we may say that anti-interference aerials possess that property by virtue of the different respective ratios of changes in signal and interference fields with respect to distance both in the azimuthal and zenithal plane.

negligible proportions the down-lead must be rendered ineffective to these fields.

It would require another article to explain why a shielded down-lead will reject the interfering fields but allow the signal fields to pass, but it should be pointed out that the simple shielding of the down-lead alone is insufficient since it only removes the electrostatic component of the interfering field. The magnetic component must be removed by using a balanced transmission line, making it necessary to provide matching transformers at both extremities of the balanced and shielded line.

Fig. 5 depicts a typical circuit of a vertical anti-interference aerial system. It will be noticed that a separate earth is connected to the aerial primary so that the shield of the transmission line is disconnected from the aerial circuit and is earthed only at the receiver end. This is a very important point because interfering EMFs induced magnetically in the shield would cause currents to flow through the primary of the aerial transformer via the capacity of the top aerial element to earth. The interference would then be transformed into the transmission line in the same manner as the signal and no rejection would result.

The design of the transformers presents many difficulties if an attempt is made to secure negligible signal loss due to their insertion. Naturally, it is impossible to match accurately the aerial transformer to the aerial impedance excepting at one frequency, and one must rely upon resonance and leakage effects to provide an average good response. At the receiver end the problem of matching the transformer to the receiver input impedance depends purely upon the value of the latter, which varies very considerably between different makes.

Some compromise is necessary in this respect, and it is usual to design for a resistive input of about 2,000 to 3,000 ohms for a good average performance on receivers selected at random.

At first sight it might appear that the overall signal loss occasioned by the use of transformers and transmission line might be high, but an important additional property which so far as the author is aware is unknown, or rather unappreciated at the moment, is introduced during the process of changing from a plain vertical aerial to the anti-interference system.

Consider a vertical wire of height $H + L$ as shown in Fig. 6 (a). The little dot

marked P represents a point at which the aerial will be cut later. A receiver is connected between the base of the aerial and ground. If the field strength is E volts per metre, the open circuit voltage "e"

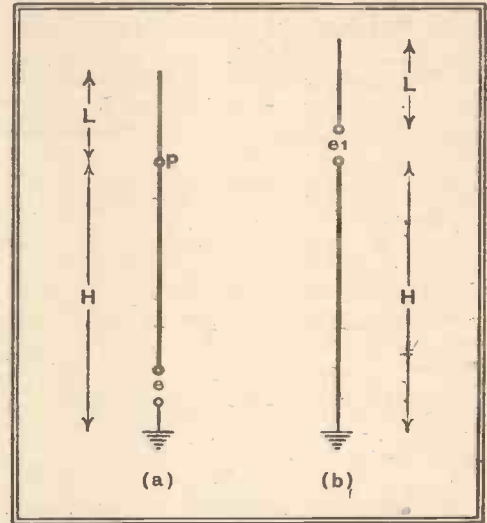

Fig. 6.—For a given uniform signal field the effective voltage for the arrangement of (a) is less than for (b).

generated across the receiver terminals will be given the expression

$$e = \frac{E(H+L)}{2}$$

Of course, it is assumed that "H" is small compared with the wavelength, and for our 54ft. aerial this condition will be satisfied over medium and long waves.

Now let us earth the base of the aerial and open the wire at the point P as shown in Fig. 6 (b). It can be shown mathematically that the open circuit voltage generated at the point is now given by the equation

$$e_1 = E\left(H + \frac{L}{2}\right)$$

so that if "L" is small compared with "H" the available signal voltage is doubled. Now by reference to Fig. 5 we see that this has been done, so that the transformer and line losses are partially offset by the increase in available signal voltage.

The full analytical treatment of the problem is beyond the scope of this article, but it is results which matter, and these in practice support fully the results of the theoretical treatment making the vertical anti-interference aerial an efficient system both for the reception of adequate signal voltage and discrimination against localised interfering fields.

It is not unusual in practice to obtain a reduction of between 30 and 100 times on local electrostatically induced interference, and a reduction of between 10 and 20 times of magnetically induced interference.

The average reduction of signal strength due to the transformer and line may be kept to within four times so that a high signal-to-interference discrimination is maintained. The results in many cases are nothing short of astounding, particularly when the interfering fields are predominantly electrostatic and are located close to the lower portion of the transmission line.

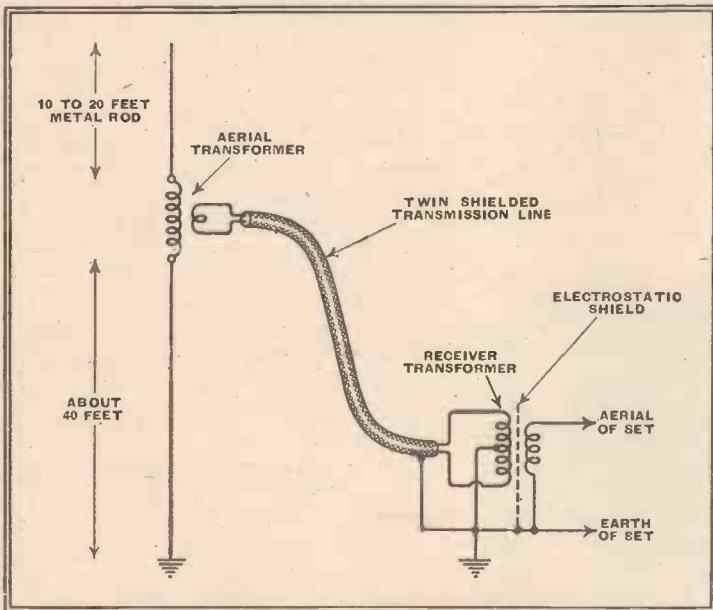

Fig. 5.—Circuit of typical vertical anti-interference aerial.

The interference effects experienced by the average town and country listener are in general caused by induction between the house wiring (which carries the interfering currents) and the down-lead from the aerial, which must naturally provide the closest coupling since it is brought into the house. Of course, indoor aerials are coupled over the whole of their length, which naturally accounts for their poor receptive properties when interference is present.

In order that the effects of the interfering fields may be removed or reduced to

Wireless on the *Mauretania*

NINE AERIALS, THREE TRANSMITTERS, DF AND BROADCAST DISTRIBUTION APPARATUS

MORE than ordinary interest is being taken in the maiden voyage of the recently completed Cunard White Star liner *Mauretania* as, apart from being representative of the last word in modern ship building, she is the bearer of a famous name. No part of a ship's internal economy has been changed so drastically as the wireless department during the generation which separates the two *Mauretania*s. In 1907, when the original *Mauretania* set out on her maiden voyage, there was, comparatively speaking, very little wireless apparatus to describe, although what there was was regarded in a far less matter-of-fact manner than is the multifarious and complex installation which the new ship is carrying on her first voyage across the Atlantic.

The wireless equipment of the new *Mauretania* is designed to enable the following services to be carried out:— Reception of Press messages; long wave telegraphy; medium wave telegraphy; short wave telegraphy; short wave commercial telephony; continuous "distress" watch; direction finding; emergency transmission on 600 metres.

To provide the above services nine aerials and three separate transmitters are employed, one for each of the short, medium, and long wave channels. The medium and long wave transmitters will

The new *Mauretania* leaving the Mersey on her maiden voyage. She will be able to communicate simultaneously with both sides of the Atlantic and with another ship.

THE progress which wireless communication has made during the past thirty years is strikingly brought out when a comparison is made between the relatively crude spark transmitter and non-amplifying receiver carried on her maiden voyage by the old Cunard liner "*Mauretania*," and the wireless apparatus carried by the new ship of that name. The apparatus carried by the new "*Mauretania*" is described in this article.

be used for telegraphy only, but the short wave transmitter is suitable for both telegraphy and telephony. There are four separate telegraphy receivers, one being reserved exclusively for Press reception. All these receivers are all-wave instruments, but each will normally be used only on one particular waveband.

The arrangement of the apparatus enables three separate telegraphy services



to be carried on at the same time. Thus, for instance, during a transatlantic voyage, the ship is able to maintain communication with another ship, and simultaneously with land stations on both sides of the Atlantic. These three services will be completely independent of the news service which, by itself, may account for about eight hours working per day.

In addition, there is the short wave telephony service. Booths have been placed near the telegraph office and the lifts so as to be readily accessible for passengers receiving incoming calls. The telephone equipment is a compressed replica of an inter-continental wireless telephone installation, and will permit passengers to communicate with any subscriber either ashore or in a similarly equipped ship in any part of the world, in complete privacy and with the assurance that no unauthorised listener can overhear their conversation. The telephone transmitter will also enable broadcasting to be carried out from the ship and relayed by broadcasting systems on both sides of the Atlantic.

Progress in Direction Finding

It is fitting that the new *Mauretania* should be equipped with the most up-to-date DF apparatus, because the original ship of that name was noteworthy as being the first merchant ship in which wireless was used for direction and position finding. The Marconi-Bellini-Tosi system was installed experimentally early in 1912, tests being made by engineers during several Atlantic crossings. In those days signal detection was by means of a crystal which was so insensitive that a DF range of about 15 miles was considered quite good. A number of interesting and important discoveries with regard to wireless direction finding at sea were made during these early voyages, and much light was thrown on the effect of the metalwork of the ship on the performance of the equipment. Since then, of course, means have been discovered for correcting all "ship" errors, and the true bearing is now read directly on the direction finding instrument.

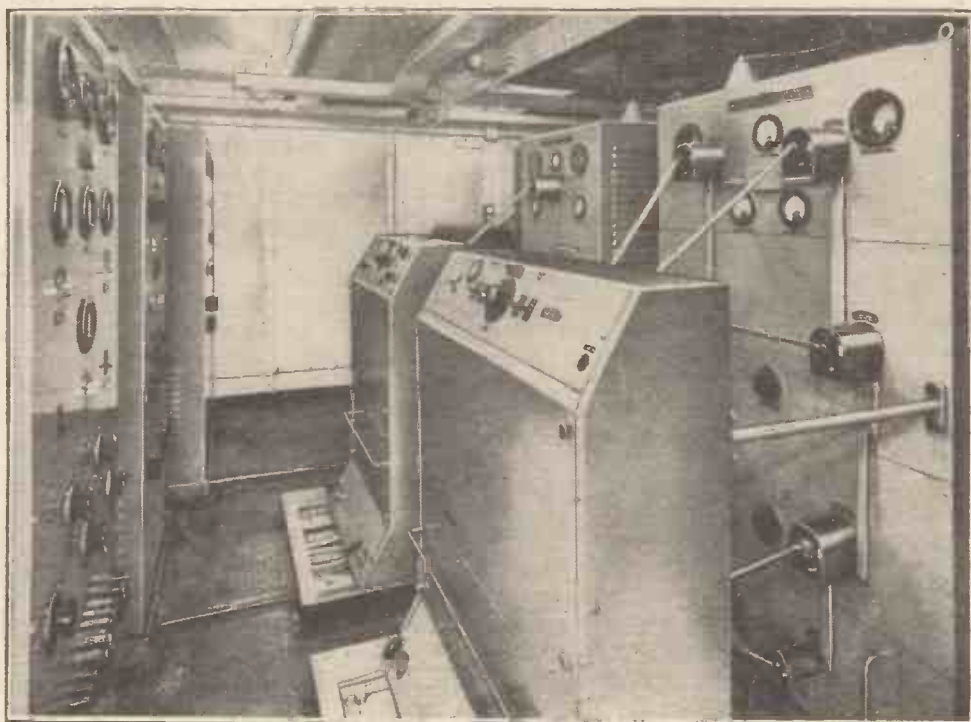

All four transmitters are housed in one room. The medium and long wave apparatus is seen here.

Wireless on the *Mauretania*—

The latest pattern direction finder, of the Marconi-Bellini-Tosi type with fixed aerial and rotating goniometer is provided on the new ship. This has been designed primarily for use on the bridge, and is housed in a robust casing which is mounted directly upon the deck. It presents an appearance similar to that of an ordinary binnacle so constructed that the direction finding scale is inclined towards the observer, and affords clear and accurate observation of bearings. The second scale on this instrument is coupled to the gyroscopic compass so that true Great Circle bearings may be directly observed. A loud speaker is contained in a panel below the scale.

The room on the bridge in which the direction finder is installed has direct access to the chart room. It is completely copper lined, and all incoming conductors are fitted with filters. This thorough screening will protect the circuits from ship's electrical interference, and so greatly facilitate operation, with a resultant improvement in performance.

The ship is equipped with auto-alarm apparatus which will maintain an automatic 600 metres watch for 24 hours per

A standard spark emergency transmitter, tuned to 600 metres, is fitted near to the automatic alarm. This equipment is



The direction finder which is mounted on the bridge enables the true bearing to be read. A second scale on the instrument is coupled to the gyroscopic compass so that true great circle bearings may be directly observed.

stopping machines, means of adjusting the power and type of emission of the transmitters, keying, etc. There is also telephone communication between the wireless control room and the three other wireless centres, communication with the pursers, and the ship's inter-communication system.

Two motor launches, one on the port and one on the starboard side, are fitted with complete wireless equipment.

Seven radio officers will be carried.

In addition to the above wireless equipment, sound reproducing apparatus provides entertainment in all parts of the ship from radio, gramophone or microphone sources. A specially designed receiver is incorporated in order to receive broadcast programmes, which can be distributed to any of the numerous loud speakers which are installed in the public rooms in all parts of the ship. About fifty loud speakers are fitted in the lounges, smoke-rooms, verandahs, dining saloons and the Grand Hall.

The PA Installation

Experience has shown that, in order to achieve a better distribution of sound, a large number of loud speakers distributed throughout a room is preferable to one or two large instruments. Consequently, this policy has been carried out in all rooms to ensure an even and pleasing tone. Also, since, as is well known, people in a room absorb sound, local volume controls are fitted so that the steward in charge of each room can adjust the volume of sound as a room fills or empties.

In order to harmonise with their surroundings, the loud speakers have been

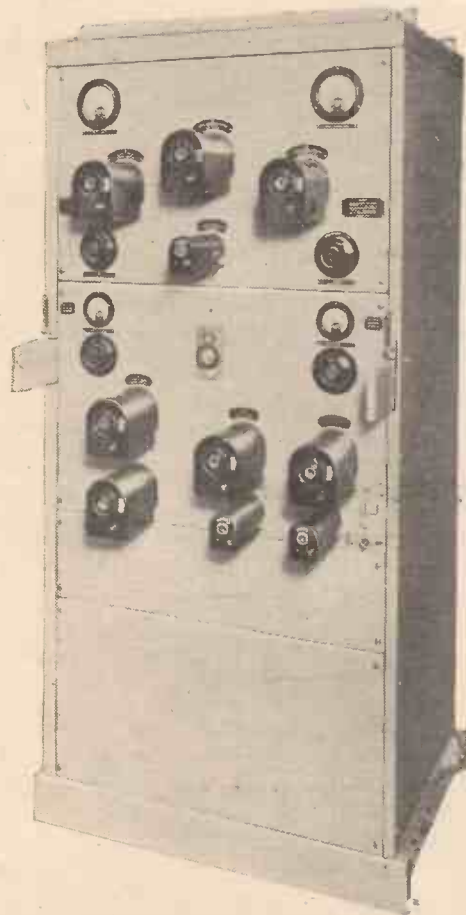

By means of the short wave transmitter, direct communication can be maintained at all times with both sides of the Atlantic.

designed to work from an emergency battery, and is the most powerful spark emergency equipment which can be installed under international regulations. The advantages of the wide frequency band of spark transmitters for real emergency work are fully recognised, and the design of the transmitter makes it especially suitable for this purpose.

Power for the transmitters and receivers is provided by three alternators, and the total driving power used when carrying out all the wireless services, concurrently will be less than 30 h.p. With the exception of the lifeboat equipment, the wireless apparatus occupies four positions in the ship. The three transmitters, and the alternators which supply power to them, are housed in two separate rooms, the direction finder on the bridge, and the remaining equipment, including all receivers, emergency transmitter, automatic alarm, etc., in the main wireless control room.

The whole of the equipment, with the exception of the direction finder, is controlled from the main wireless control room. These controls include starting and

The echometer sounding device makes use of supersonic pressure waves through the water to plot a contour of the sea bed.



day. In the event of an alarm call being received, this instrument rings bells to call the attention of the radio officer and the officer of the watch. A loud speaker can also be used if required. This auto-alarm is of unusually robust construction, and a special test unit is incorporated so that the sensitivity can be checked at any time.

Wireless on the *Mauretania*— built into the structure of the ship. In several cases the loud speakers are hidden in the ceilings of the rooms. For example, in the Grand Hall eight loud speakers have been arranged in the round of the dome.

The main feature of this PA installation is its great flexibility. While a broadcast programme is being relayed to certain rooms, other parts of the ship can be

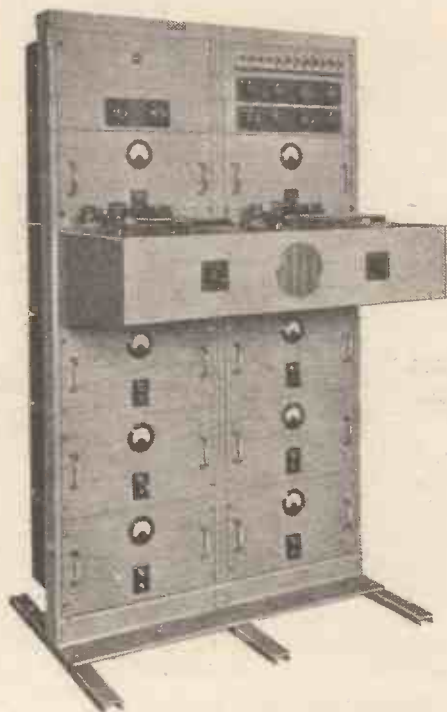

The P.A. apparatus enables broadcast concerts, programmes of gramophone records, or concerts given aboard, to be distributed throughout the ship.

supplied with music from gramophone records, the ship's orchestra being relayed simultaneously to yet another part of the vessel. These programmes are completely interchangeable, and their distribution can be altered at will from a central control panel.

The bridge of the *Mauretania* is also equipped with the Marconi echometer sounding device, by means of which the present-day navigator can obtain, in a moment, the depth of water under the ship, no matter how quickly this may vary. The officer of the watch can obtain this information in the comfort of the chart room, with his charts before him, and without the necessity of calling other members of the crew from their ordinary duties. Those who have had experience of the ordinary methods of depth sounding by swinging the lead will appreciate the advantage and convenience of this.

Use is made of pressure waves through the water, these being emitted by the echometer at a frequency above the audible limit. The advantage of using these supersonic frequencies is that they can be concentrated into a beam, which means that they can be transmitted vertically from the ship's hull, with a consequent economy in power. Reception, being within a sharply defined area, is not affected by submarine or other parasitic noises. Two means of indication are provided, the visual indicator and the automatic recorder. With the visual indicator, the depth of water under the keel is shown many times a minute by a "peak" of light on a calibrated scale. The recorder automatically plots a graph of the contours of the sea bed. These are compared with the known contours of the sea bed as recorded in charts, and so enable the navigator to fix the ship's position with reasonable accuracy. In addition, when the echometer is used in conjunction with the DF apparatus, the navigator can obtain a further check by comparing the reading obtained by one instrument with that of the other and with the depths indicated on the chart.

The whole of the installation has been carried out by The Marconi International Marine Communication Co., Ltd., which also supplied the equipment on the original *Mauretania*.

In Forthcoming Issues

VIBRATORS. An outline of the principles of operation and factors influencing their design.

EXPONENTIAL HORNS. Calculations of curvature reduced to their simplest terms.

MICROPHONES AT ALEXANDRA PALACE. Description of the E.M.I. ribbon and moving-coil types.

PROBLEM CORNER-25

An extract from Henry Farrad's correspondence, published to give readers an opportunity of testing their own powers of deduction :—

Howell House, Keston.

Dear Henry,

I have recently made up a small battery set to use in our week-end bungalow, where, of course, no mains supply is available. It went beautifully the first time I took it down there; the next few times the tone seemed rather distorted, and after a few weeks the HT battery which had been brand new, was run right down. I thought it might have been rather a dud battery, so got another, but the same story applies to it. I am quite certain that something is wrong, because batteries used almost every day in other sets last longer, and the tone is only good the first time the battery is used on my set.

I enclose the circuit diagram in case it is of any help. I have checked over the connections carefully; as you see, the switch is arranged to disconnect both LT and HT, and a combined HT and GB battery is used. The usual accumulator LT seems to function normally, and I have taken good care to see no acid has leaked out. The HTB is kept quite dry. But perhaps you can suggest something.

Yours sincerely,
Philip Cowe.

Why were Mr. Cowe's results so unsatisfactory?—Solution on page 589.

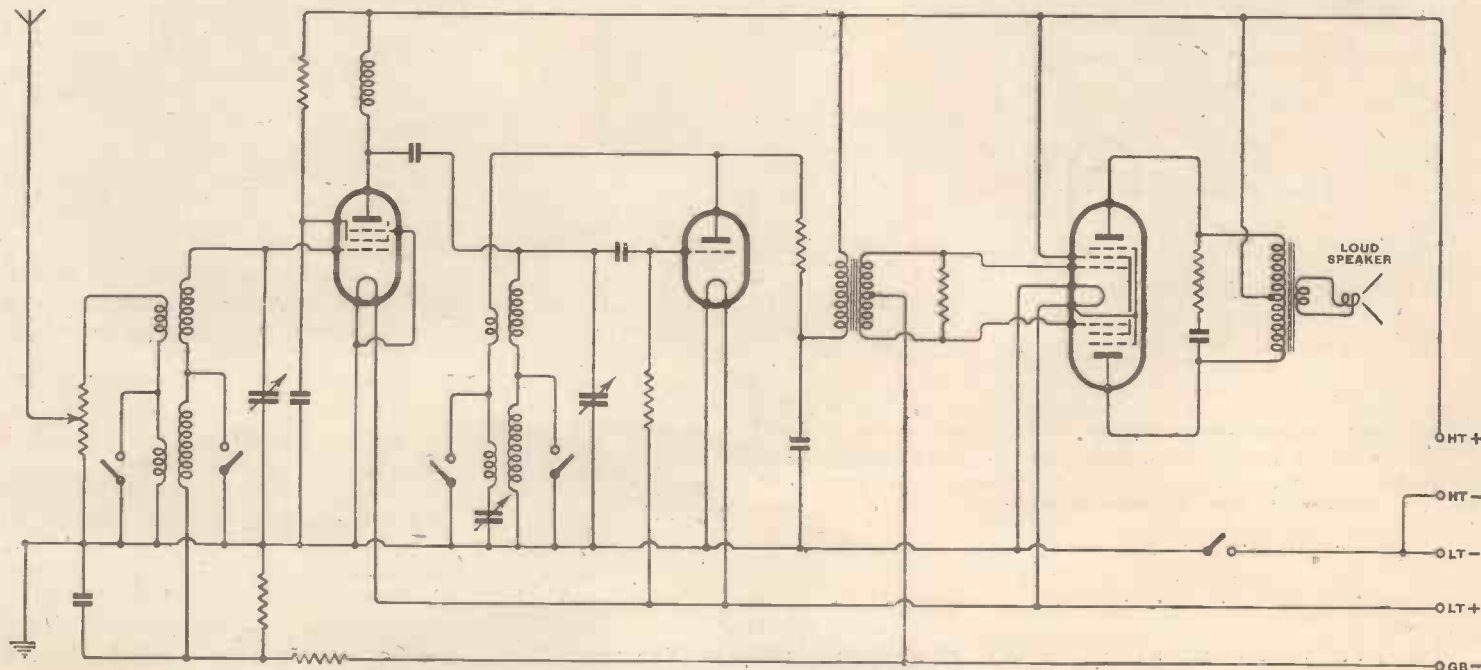

The circuit diagram mentioned in Philip Cowe's letter.

Adding a Beat Frequency Oscillator

By D. P. TAYLOR

COMMUNICATION SET FEATURE APPLIED TO A DOMESTIC ALL-WAVE SUPERHET

THE specification of all modern communication-type receivers includes a beat-frequency oscillator (BFO for short), as the use of such a device is essential for the reception of morse signals with a superheterodyne receiver. It is not, however, generally appreciated that it can also be of great use to the listener who is interested only in the reception of short-wave broadcasting stations.

When a receiver of this type is tuned to a broadcasting station during an interval in the programme, the only indication of the presence of that station is a fall in noise level as the AVC comes into action, or a deflection of the tuning indicator if one is fitted.

The receiver actually handles in much the same way as a straight set with the reaction control below the point of oscillation. If the station is very weak, or at the trough of a deep fade, it may be passed unnoticed, and in this way a station is missed, whereas had its

THE small unit described in this article can easily be added to most modern superhet receivers and it will greatly enhance the enjoyment of short-wave listening. By making all carrier waves audible, stations are not passed over unknowingly and many of them can be brought up to good programme level by careful adjustment of the set. It also enables CW transmissions to be received on an ordinary domestic all-wave superhet



separate heterodyne valve which was sometimes used with early short-wave sets for searching and for the reception of morse stations. A BFO is exactly the same thing, with the advantage that as the IF is fixed, variable tuning, wave-change switching, ganging, etc., are unnecessary.

It is a simple matter to add a BFO to practically any short-wave superhet, either home-made or commercial, and the unit shown in the accompanying photograph was actually designed to fit into the cabinet of any modern mains-operated receiver.

BFO Circuit

The circuit diagram is shown in Fig. 1 and it will be seen that a screen-grid valve is used as an electron-coupled oscillator.

The tuned circuit LC1, which determines the frequency of the oscillations, can be purchased complete in a screening can similar to that of an IF transformer, or it can be made easily by those interested in home construction.

As most modern receivers have an IF between the frequencies 450-470 kc/s, the unit is designed to cover this range, the exact adjustment being made by the trimmer condenser C1 inside the screening can.

No difficulty should be experienced in obtaining oscillations if the correct type of valve is used; an ordinary screen-grid valve proves very suitable and has the advantage that the anode and screen current requirements are very small. The final choice of valve will be governed by the heater voltage of the receiver, for a 4.0-volt supply an AC/SG or a KTZ63 for 6.3 volt are suitable, but valves having similar characteristics could be used. Screening of the valve and tuned circuit is necessary to prevent the possibility of

lation, and a beat note is then heard as the receiver passes the frequency of the transmitter.

What is required, then, is some means whereby the same effect can be obtained with a superheterodyne receiver.

The obvious thing to do is to make the second detector regenerative so that it can be used in an oscillating condition for searching.

This has, however, a number of disadvantages, such as, for example, increased noise level, difficulty of adapting an existing receiver, risk of circuit misalignment, and in any case a diode is usually used as a second detector in a modern receiver. Fortunately, a similar effect can

be obtained by the use of a BFO, which is simply an oscillator tuned to a frequency near to that of the receiver IF, with which it beats, and so produces an audible note after rectification by the second detector.

Possibly older hands will remember the

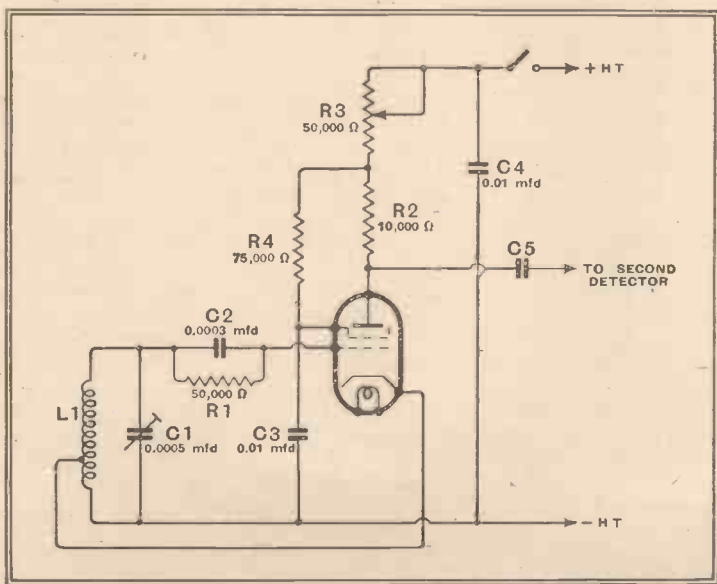

Fig. 1.—Circuit diagram of the beat frequency oscillator unit. If adjustment of beat note is desired C1 can be replaced by a smaller fixed condenser with a variable trimmer wired in parallel.

presence been known it might have been brought up to a satisfactory level for reception by careful manipulation of the controls.

This difficulty is overcome in the case of a straight set by searching on the short waves with the receiver in a state of oscil-

Adding a Beat Frequency Oscillator—

interaction between harmonics of the oscillator and the signal frequency circuits causing "false carriers" to be generated.

The degree of coupling to the second detector is not very critical, but it should be kept fairly loose as this is more favourable for the reception of weak signals, another point in favour of screening.

The anode of the BFO valve is coupled to the anode of the second detector diode (or the grid of the second detector if a triode or tetrode is used) through a coupling condenser C₅ of the order of a few micro-microfarads. This condenser can consist of a few turns of insulated wire twisted around the diode anode lead.

A variable resistance R₃ is included in the anode supply to the valve, and this should be adjusted to the maximum resistance value which gives satisfactory oscillation, and once set it should not require further adjustment.

For the benefit of those interested in home construction, the following details of the tuned circuit are given: The coil

L₁ consists of 170 turns of 36 SWG double silk-covered wire on a paxolin former in diameter, the winding length being approximately 1 1/2 in., the cathode tap being 55 turns from the earthed end.

This coil has an inductance of about 350 microhenries, so that a capacity of approximately 0.00035 mfd. is required to tune it to 465 kc/s. A pre-set condenser having a maximum value of 0.0005 mfd. is satisfactory.

A finer control of frequency can be had by the use of a trimmer of smaller value shunted by a "postage stamp" type fixed condenser.

As the BFO will be used on occasions only, and not continuously, a switch can be fitted in the position shown to cut it off when not required.

In the unit shown in the photograph a small variable condenser is connected across the coil for adjustment of the beat-note frequency and a corner of one of the moving vanes is bent over so that it short-circuits in the position of maximum capacity and so acts as an on-off switch.

against Messrs. Pacent and Likel's criticisms of it published in your issue of May 18th, on the subject of reproduction level, I am venturing to break into the correspondence. My satisfaction with Mr. Hughes's letter, unlike Messrs. Pacent and Likel's, is unqualified, for I agree with every word of it, and feel that the gap shown by the latter correspondents between original and reproduced sound levels is exaggerated, as is also the description of the drastic results that would follow an attempt to reproduce sound in the home at concert loudness. In doing so, I would recall the actual measured results I contributed to the issue of March 10th, 1938, in an article, "Loud Speaker v. Orchestra." These were obtained with a General Radio Sound Meter, used to compare original full orchestral performances in the Queen's Hall during rehearsal with the same items during the concert later in the day, reproduced in a typical living room about 14ft. x 12ft., with, if anything, more than the average amount of sound-absorbing surfaces, supplied by a push-pull triode output stage rated at only 1 1/2 watts and feeding an old 10in. R.K. energised loud speaker.

The level marked in Pacent and Likel's article as "Concert Hall Energy Level," approximately 100 phons, is nearly the loudest I observed at the peak of such an exceptionally noisy piece as Strauss's "Also Sprach Zarathustra"; and as it is described by them as *maximum* orchestral reproduction my measured results seem to be in good agreement. But the level marked "Home Energy Level," and described as the maximum normally tolerated, is only about 70 phons (even when boosted somewhat in the bass); whereas in my home tests it was possible to obtain the full concert hall meter readings without overloading the very moderate output stage or producing excessive loudness for listening. I say "listening," because I assume Pacent and Likel are considering this, and not people who wish to concentrate on a book, still less those who want to carry on a conversation. The *average* loudness during the concert was, of course, much less than the above maximum—actually it was in the region of Pacent and Likel's "Home Energy Level"—but in the concert hall it would, if anything, be less still, owing to the programme control bringing up the gain on quiet passages.

When adjusted for full concert hall loudness, the reproducer was not audible to neighbours; though this statement probably would not hold good for open windows or flimsy party walls. Even so, it is not certain that it would be considered a serious nuisance, as symphony concerts are not a large part of the programme material, nor are climaxes a large part of symphony concerts. If music haters insist on being in the same room, or very close to it, there is no difficulty in equalling or even exceeding concert hall loudness with a few milliwatts, by resorting to high-quality headphones.

I consider, then, that sound reproduction at original loudness is not so much out of the question as is often thought.

"CATHODE RAY."

AUTOMATIC FREQUENCY CONTROL

IN connection with the article under the above heading on page 545 of our June 8th issue, we are asked to point out that the principle of operation has been evolved as a result of research work in the laboratories of the Telefunken Company.

Letters to the Editor

Gramophone Records

IN the course of some correspondence dealing with recording matters I believe certain readers were good enough to suggest record titles worthy of inclusion in one's library.

Perhaps space could be found to republish these in collected form. Record purchase still seems something of a lottery—"wire edge" top register and banjo-like piano tone are all too familiar.

Could the recording companies be persuaded to mark or catalogue items which are particularly interesting on the score of technical excellence?

Maybe, candour in affairs commercial cannot reasonably be expected to go to such lengths. However, I have a notion that Mr. Voigt could furnish a very useful list.

London, S.W.15. J. L. GREATOREX.

Quality from Headphones

MANY thanks to Mr. Partridge for his article debunking the "straight-line" fetish of the quality fans. This sensible comment on the futile chase after "perfect" reproduction was long overdue.

For myself listening is a serious matter, wherein not only excellent quality *as heard by my own ear* and not by the whole street, but complete absence of distractions, are necessary conditions for the enjoyment of the items that I select for hearing. So I have one set for the family, which drools out dreary dance-music the whole day and about the quality of which I do not care two hoots, and a pair of phones carefully matched to the medium impedance triode output of a simple RF-det.-AF set for my personal listening. This gives me, owing to the sensitiveness of the phones, the choice of quite as many programmes as the family superhet, and incomparably better quality.

For high-quality headphone listening, good phones are essential. They need not be extremely sensitive; indeed, low resistance windings and a good output trans-

The Editor does not necessarily endorse the opinions of his correspondents

former are best. But the distance between the diaphragms and the ear-drums should be the least possible. The diaphragms themselves respond extraordinarily well over a very wide range of audio frequencies, but losses occur mainly in the air space mentioned.

I have obtained superb effects by using a medical stethoscope applied to a single old-fashioned horn-type speaker unit and believe there are possibilities in a modernisation of this system.

In conclusion, may I say that there is more in Mr. Partridge's article than mere debunking? It is also a reminder that there is a profound difference between the art of communication over long distances by radio, and the art of loud communications over short distances by air vibrations—which latter is better known as Public Address.

As a radio man pure and simple, I am not interested in PA. What happens after I have produced an audio-frequency voltage or reasonable magnitude by means of "detection" from a high frequency carrier wave, is not my pigeon; the PA people can amplify it up to entertain a whole town if they want to. For me the interest lies in producing that small audio-frequency voltage—picking it out of the congested muddle of etheric vibrations after it has come, perhaps, from the far ends of the earth. That is true radio. The rest is public address work. It is time that serious technical radio men realised it and concentrated on their own speciality.

Swindon.

"INSTRUCTOR."

Reproduction Level and "Scale Distortion"

AS Mr. J. R. Hughes has not come forward with a defence of his letter, published in *The Wireless World* of April 13th,

NEWS OF THE WEEK

RADIO RELAYS

Major Tryon Outlines the Post Office Plans in the House of Commons

THE debate on radio relays in the House of Commons last week was preceded by a statement from Major Tryon, the Postmaster-General, in which he said that although it was the intention that wireless broadcasting should go on in time of war, the system would be liable to deterioration or occasional interruption as a result of interference from various sources, from which a wire service would be immune. Therefore, the Government desired to develop wired broadcasting to the maximum possible extent. The relay companies with their existing plant and resources could make a valuable contribution towards the Government's objective, and he hoped that local authorities would bear that aspect of the question in mind, and give favourable consideration to applications from suitably qualified companies.

He made it clear to the House that it was no discredit to the Post Office, with the immense amount of work that they were doing, to say that they would get more wire broadcasting if they also called in the aid of the relay companies. Licences to such companies will be extended for a further period of ten years from January 1st next, subject to certain modifications in regard to the programmes supplied to subscribers and the control of exchanges in time of emergency. The new licences will also contain a provision enabling the P.M.G. to require a relay company to lease wires at a suitable rental for the purpose of obtaining programmes from a B.B.C. studio entirely by wire.

Telephone Broadcasts

Dealing with the proposed Post Office telephone broadcasting service, Major Tryon said that the subscriber would be able to use his ordinary receiving set which could be adjusted and attached to his telephone. He would still be free to get in touch with any station he might fancy at home or abroad. The radio trade was prepared to supply and maintain receiving sets of special design which would enable the best use to be made of the telephone broadcasting service. On the assumption that the arrangements would prove satisfactory, he proposed to start the service on the basis that all sets used by subscribers would be supplied and main-

tained through the usual trade channels.

The Post Office, he said, was in consultation with the B.B.C. concerning the arrangements to be made for the selection of good foreign programmes to supplement the B.B.C. programmes.

He hoped that about the end of this year a Post Office telephone broadcasting service would be started in the Central London area and practically the whole of Edinburgh, Birmingham and Manchester. The cost to the subscriber, he said, would be less than 1s. per week and the more it was under 1s. the better the Post Office would be pleased. Following the debate, which resulted in a Government majority, Major Tryon said that although experiments with the use of electric light wire for relay had not been successful in the U.S.A., the G.P.O. were continuing their examination of this matter to see if this very useful existing set of wires could not be put to further use. It was proposed that the relay services should be connected now, he said, so that if an emergency should arise they could, if necessary, maintain the ordinary broadcast services at once.

"EMPRESS OF BRITAIN"

Wireless on Their Majesties' Return Journey

EVERY facility that wireless can offer—with the possible exception of television—has been at the disposal of Their Majesties, the King and Queen, on their return journey across the Atlantic in the *Empress of Britain*.

The vessel's wireless equipment includes Marconi telegraph transmitters and receivers for long and short wavelengths, short-wave duplex telephone apparatus with world-wide range, a wireless direction finder and two lifeboat wireless installations.

It is possible to arrange microphones in selected places aboard the ship to relay the orchestra, concerts and other events of interest. By means of a special wireless receiver, broadcast programmes can be received and distributed throughout the ship and gramophone records can be used to relieve the orchestra.

In addition to handling the enormous amount of telegraphic traffic accruing from Their Majesties' presence aboard the liner, the equipment offered immediate facilities for the King and Queen to speak direct by radio telephone to either Canada or to Great Britain during the whole of the voyage.

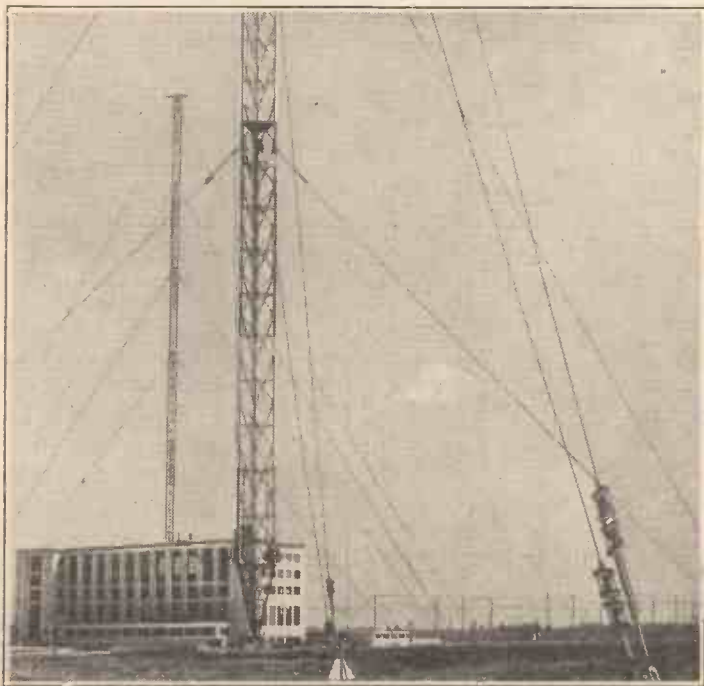

THE NEW 450-kW RADIO-PARIS transmitter at Allouis has recently been conducting night tests on 1,648 metres. The station is equipped with four 250-metre radiating masts for which special anti-fading qualities are claimed. In the background of this picture can be seen the transmitting aerials of the French short-wave station, Radio-Mondial.

SUNDAY AFTERNOON TELEVISION

Summer-Time Close Down

WE understand that Sunday afternoon television programmes will be temporarily suspended during the summer holiday period from July 16th to September 17th inclusive. Some reduction of programme hours is essential owing to the absence of staff on holiday, and it is believed that this arrangement will cause the minimum of inconvenience to viewers.

Another reason for the cancellation is the fact that most of the staff have joined some form of National Service, which requires absence for training.

AFTER MONTREUX

Power Increases in Scandinavia

A VERY substantial increase in the power output from Scandinavian medium- and long-wave broadcasting stations will occur when the Montreux Plan comes into force.

Denmark

Denmark will bring her number of medium-wave stations up to three with the erection of a new transmitter at Thorshavn, Faroe Islands. It will operate on 359.7 metres (834 kc/s) with a power of 5 kW.

Sweden

The present number of Swedish transmitting stations on the medium- and long-wave band is 31. Two new stations are to be added at Alvesta and Gotland. The following power increases are planned: Motala will raise its power from 150 to 200 kW, Sundsvall and Gothenburg from 10 to 120 kW each, Falun from 2 to 100 kW, Hörby from 60 to 100 kW, and Kalmar and Halmstad from 0.2 to 10 kW each.

Norway

In Norway, 14 transmitters with a total power of 353 kW are in operation, and the proposed addition of four new stations will raise this figure to 365 kW.

Finland

Apart from the new Olympic Games central short-wave transmitter at Bjorneborg, which will work with a power of 100 kW, Finland will not add to her present number of thirteen stations, but three of them will increase their output: Turku from 0.5 to 100 kW, Helsinki I from 10 to 120 kW and Helsinki II from 1 to 10 kW.

The estimated output of Scandinavian stations by March next year will be 1,670 kW, as compared with 995 kW at present.

THE DIRECTOR OF TELEVISION SPEAKS

MR. GERALD COCK, B.B.C. Director of Television, will, in a television talk at 9 p.m. on June 26th, to discuss

News of the Week—

the results of a recent questionnaire which yielded more than 4,000 replies. He will also take this opportunity to thank the viewers who responded.

It is not thought likely that any further questionnaire will be issued to viewers yet, but the B.B.C. wishes to keep the viewers' register up to date by adding the names of those new viewers who are prepared to cooperate in similar ways in the near future.

NO RADIO RELAYS IN GRIMSBY

A DEPUTATION from the Grimsby Chamber of Trade, the Grimsby and District Radio Engineers' Association, and the local Radio Retailers' Association, recently placed before the town's Highways Committee objections to the establishment of a radio relay system in their territory. Following the representations, a proposal that the Committee should not consider an application for a relay service in Grimsby was carried by a large majority.

COPENHAGEN'S NEW BROADCASTING HOUSE. An architect's sketch of the buildings which will house the central studios of the Danish broadcasting organisation is shown below, and, on the right, is seen a section

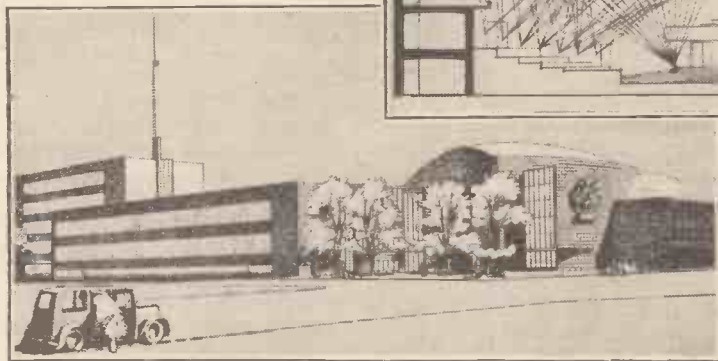

of the concert hall in which the interior of the roof has been designed to distribute sound from a number of sources equally over the auditorium. Work in the studios is already well advanced and they should be ready for occupation in the early autumn.

MOUNTAIN-TOP COMMENTARY

AN unusual programme involving a number of technical complications was recently broadcast over the Canadian Broadcasting Corporation's National network through Calgary from Sunshine Ski Lodge, 7,300 feet above sea level, almost on the Great Divide.

The Lodge is permanently equipped with a 50-watt Marconi short-wave transmitter-receiver, and C.B.C. engineers utilised this link for the purposes of relaying a mountain-top commentary on Canadian "Alpine" sports. At the receiving end in Banff Springs, some fifteen miles away, the output of two receivers was fed to Calgary over one of the permanent programme lines of the Canadian Pacific Railway.

**FROM ALL
QUARTERS****Radio Albania**

ITALY has arranged a regular series of broadcast programmes from the Tirana (Albania) short-wave station. Most of the transmissions will be relayed by Italian stations.

Spanish Broadcasting

SPAIN has been officially recognised as a full member of the International Broadcasting Union.

Radio Tunis

THE work of reconstruction of the French station Radio Tunis is likely to be completed by October 1st. The power of the transmitter will be 120 kW.

Radio Relays in Australia

A PRIVATE company has undertaken radio relay installations in Sydney and Melbourne, Australia.

Small Ships Wireless

ONE of the smallest ships afloat to be equipped with duplex wireless telephony is the tender *Greelings*, of Southampton. The installation, which has been carried out by Marconi, replaces a simplex set.

Amateurs Abroad

NORWEGIAN radio amateurs have been invited to attend summer manoeuvres of their army. They will be provided with free equipment, uniform and rail fares.

Axis Trading

NEW apparatus has been designed in Berlin to meet the Italian requirements for the broadcasting of eight simultaneous programmes from the new studios which are to be opened in Rome and Turin at the end of the year. Manufacture of the equipment was carried out by Italian labour in Milan.

Licences Rise Again

THE total number of British receiving licences in force at the end of last month was approximately 8,984,250. It may be remembered that the total of 8,962,850 for the previous month, April, was 5,259 less than the March figure. The latest total, however, shows an increase of 15,650 over that total.

New Indian Station

THE new Marconi 411-metre 5-kW transmitter shortly to be opened near Hyderabad City, India, will provide programmes in English and the vernacular.

N.B.C. Television

LONG-DISTANCE television reception has been the monopoly of B.B.C. televiewers since 1936, but reports of similar achievements are beginning to arrive from the U.S.A., where G.E.C. engineers in Schenectady have received good pictures from the N.B.C. television transmitter in New York City, 130 miles away. Perhaps America will one day achieve the Alexandra Palace record of 3,000 miles.

B.B.C. Arabic Service

MR. A. E. H. PAXTON has accepted the appointment of Arabic programme organiser in the Overseas Department of the B.B.C. Mr. Paxton, who has been English master in Egyptian secondary schools, was educated at Eastbourne College and Oxford, where he obtained honours in Oriental languages and gained the James Mew scholarship in Arabic.

New B.B.C. Service Starts in "Small Hours"

AT 12.25 a.m. (B.S.T.) on July 3rd the B.B.C. will launch a new service from Daventry for Latin-American listeners, and it is expected that a party of foreign diplomats will be present at Broadcasting House for the inaugural programme. Thereafter the daily schedule for the new service will be 12.25 to 2.15 a.m. (B.S.T.).

Belfast Radio Station

A NEW radio station has been brought into operation by the Air Ministry at Belfast Harbour. This station, call-sign GVE, will transmit on 350 kc/s (857 metres) and will function as an area station in place of Newtownards, which will become a "collaborating" station.

Broadcasting Houses

It is reported in the German Press that work will begin in the near future on the construction of new broadcasting houses at Leipzig, Munich, Stuttgart, Cologne and Saarbrücken. Building plans have been prepared and sites bought, but no further progress is yet evident.

Police Wireless

THE latest type of two-way police radio equipment was supplied by the Canadian Marconi Company to the Police Department of the City of Sherbrooke, Quebec, to assist that department to control traffic on the day Their Majesties visited Sherbrooke.

Emergency Equipment

A NUMBER of Grampian "Control" amplifying units were employed in connection with the Chelsea air raid exercise which was carried out on an intensive scale last Monday. Each PA unit comprises a battery operated amplifier which is also designed for use on AC mains, a loud speaker mounted on a tripod, and rotatable for purposes of sound direction, and a hand microphone. Units set up at pivotal points in Chelsea were used by air raid wardens for crowd control.

New Aerial Design

A SERVICE area increase of 20 per cent. at night is claimed for a new type of aerial used at the Stolp relay station in Germany. The aerial system is supported by a circle of six 150ft. masts and a central mast of the same height.

German Radio Show

WORLD-WIDE propaganda for German television will again be the main feature of the Berlin Radio Show which opens on July 28th. Ever since 1929 Germany has made television a feature of the exhibition, but the apparatus shown has never yet been put into service except for the experimental service which is transmitted in Berlin. The O.B. vans shown at last year's exhibition have not been used in public since. Other features of the exhibition will be a "Children's Broadcasting Corner," and sports in the gardens.

Europe's Receivers

THE International Broadcasting Union estimates that 35,130,000 wireless receivers are now in use in Europe. To-day, the Union begins its radio-drama conference at St. Moritz, Switzerland.

Logic

COMMUNITY sets in India are seriously restricting licence revenue. In consequence, the Government has placed before its Provincial Governments a plan whereby the licence fee for such receivers would vary according to the local population. The minimum fee of Rs.25 would increase to Rs.300 for a population of 100,000. The Government justify their scheme by pointing out that municipal bodies generally pay Rs.300 for the services of a band for one hour. By comparison, therefore, the cost of a year's broadcast programme is not excessive.

Facsimile—WHAT IT IS AND HOW IT WORKS

SO little has been published in this country about facsimile broadcasting that readers who didn't see the article on it in *The Wireless World* a little over a year ago* may not even have a clear idea of what it is. As the name suggests, it is an exact reproduction at the receiver of print, handwriting, pictures or other matter transmitted. In this exactness it is distinct from radiotelegraphy, which, in some systems, may actually print the message on paper but cannot copy the characters of the original or reproduce pictures; while television, though reproducing the original forms, does so transitorily, not permanently on a piece of paper—unless, of course, one photographs the screen. The motion in television is absent in facsimile broadcasting, but against this there is the advantage of being able to send it on any ordinary broadcasting channel, and receive it on almost any receiver, given the necessary extra apparatus.

A number of American broadcasting stations started facsimile services last year, and the standard of reproduction is remarkably good. Catty critics will no doubt have been suggesting that this development is to console Americans for being so far behind us with television. Well, the Irishmen over there may retort that if we rest on our laurels much longer the laugh will be on the other foot. However, even in this facsimile business, the American service came nearly ten years after the British. It may be a surprise to many people to know that there used to be a regular B.B.C. service of picture broadcasting. Anybody who, like myself, made use of this service is unlikely to be surprised that it was not noised abroad with much pride. One had to play about with wet sheets of paper in order to receive

* March 3rd, 1938.

By

"CATHODE RAY"

very indifferently reproduced pictures with an entertainment value that it would not be too harsh to estimate as nil. The modern systems used in America—one of them, by the way,

Facsimile receivers record the news on long rolls of paper, as shown here. In the case of de luxe models printed sheets, more closely resembling the make-up of an ordinary newspaper, are delivered.



bearing the same name as that used by the B.B.C.—can be left to work themselves overnight, and confront the owner of the set with a 30ft. roll of newspaper for his breakfast, or, if he has a *de luxe* model, a neat pile of printed sheets.

Even in the days of the B.B.C. experiment the principle was not new. It is essentially the same as in Bain's facsimile telegraph of about a hundred years ago, and its use for newspaper-picture transmission has been growing for years until now it has reached a high state of development. The broadcast apparatus is just an adaptation of these commercial systems to domestic conditions. It can be looked on as an enormously slower—and therefore easier—television process. The matter to be transmitted is scanned, using a light beam and photocell, and the amplified

output used to control the strength of a continuous 3,000-c/s note from the transmitter. In one arrangement the light beam itself is interrupted by a toothed wheel at this frequency. The object is to transpose all the signal frequencies up into a band that can be effectively amplified by ordinary apparatus, instead of having to deal with abnormally low frequencies such as 1 c/s. In between lines a synchronising signal is sent out, but being a still picture there is, of course, nothing corresponding to the television frame-synchronising signals that are needed to return the scanning back to the beginning again after the completion of the picture.

At the receiving end the varying 3,000-c/s note, which may be considered to be a sub-carrier wave on the radio-frequency carrier wave, is diverted from the loud speaker (where its effects would be rather disturbing!) to the special picture apparatus, consisting of a motor for moving a stylus line by line over a roll of paper slowly fed forward by gearing, and a relay system for producing marks on the paper corresponding to the momentary strength of the low-frequency carrier wave. Some sets mark the paper by means of pressure on an interleaved sheet of carbon paper; others by removing the surface of special paper, disclosing to varying degrees a dark layer beneath; and yet others by an electrolytic effect.

Wide Frequency Band Not Required

The width of the paper is anything from 4 to 8½ in., according to the system; and there are 100 lines per inch length, taking 1 minute to transmit. A section 4 in. long is therefore comparable in definition with a television "frame," but as it takes 6,000 times as long to put across—4 minutes instead of 1/25th of a second—it

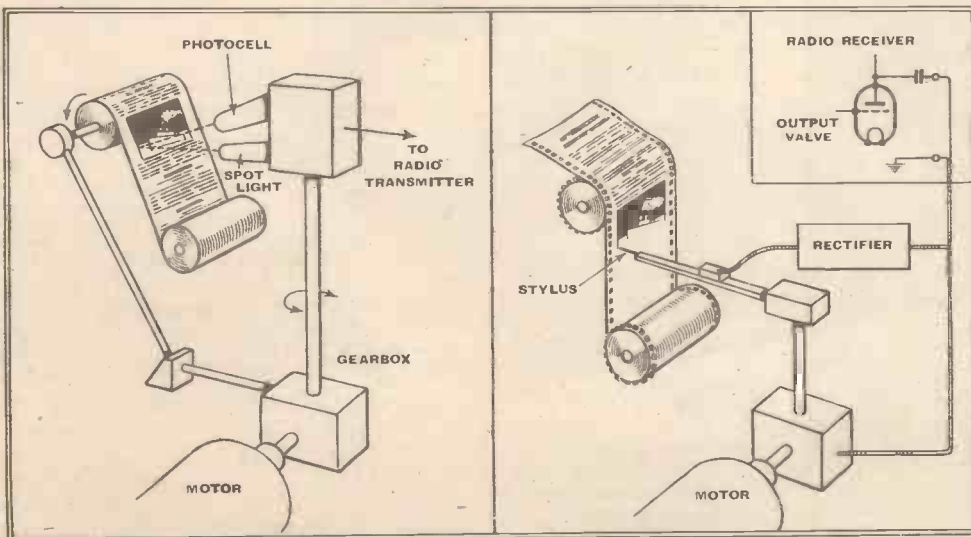

The principle of a facsimile broadcasting system is illustrated here. At the transmitting end the matter to be broadcast is scanned by a light-sensitive device, and the resulting signals used to modulate a 3000-cycle note sent out by the transmitter. At the receiver a valve adapter taps the signal from the output stage and uses it to control the marking of the paper and also to synchronise the scanning and paper feed.

Facsimile—

is to be expected that a larger proportion of the theoretical maximum definition is actually realised in practice. Assuming a 4in. width, and allowing a small fraction of time for the fly-back between one line and the next, the speed of marking is about 8in. per second, which may be compared with the 100,000 inches, or over a mile and a half per second, traced out by the cathode ray in a television receiver. As we know, the frequency at which this ray is modulated in order to fill in the detail goes as high as several million cycles per second. It can easily be calculated that, in facsimile, the corresponding figure is about 400 cycles per second, so a sub-carrier wave at as low a frequency as 3,000 c/s can easily be modulated at this rate, and there is obviously no difficulty in broadcasting it on any wavelength from ultra-short to long.

In the latest receiver the paper width is 8½in., and, instead of a single stylus moving backwards and forwards, there are three mounted on an endless chain so that one is always in contact with the paper. Printed matter can be transmitted at about the same speed as it would be delivered verbally in a news bulletin.

News Distribution

Most of the comments that have been made in this country are rather sceptical about the value of facsimile broadcasting, and doubtful about who would be likely to pay the cost of the service. So far as our own country is concerned there is plenty of room for doubt, especially as television will need all the development that can be devoted to it in the coming years if it is to be a really national service justifying the costly pioneer work that has been put into it. There are already so many calls on funds for existing broadcasting services that facsimile would have to queue up at the end of an almost stationary line. Then, again, we have the most highly developed national newspaper system in the world, and there is hardly a corner in the kingdom where a paper cannot be delivered on the day of issue by the ordinary means of circulation.

The situation is quite different in the U.S.A. The territory is vastly greater and, no doubt, it is very valuable to be able to distribute printed matter instantaneously everywhere. In fact, facsimile is so highly thought of that it was included among thirteen inventions picked out by President Roosevelt's National Resources Committee as carrying "vast potentialities for economic, social and cultural change." Apart from newspaper matter, in such a large area there are special advantages in being able to broadcast the description, photograph and fingerprints of a fleeing criminal. As regards the facilities for carrying on the services, broadcasting stations are much more numerous than they are here, many being owned by sectional interests. Surprisingly enough, most of those doing facsimile are owned by newspaper concerns. This being so, one does not have to look far to see a probable source of revenue. The sound

broadcasting business in America is kept going by advertising. If this is so for sound, isn't it still more likely to hold good for permanently recorded matter? Press advertising is regarded by the experts as the foundational medium, and, presumably, facsimile broadcasting is included. Indeed, one would expect broadcasts to be scrutinised more closely than ordinary printed matter.

As the extra unit for facsimile reception costs something like £10, even if produced in quantities, it has to justify itself by showing advantages over spoken news. One obvious drawback of the latter is that one has to listen all the way through or run the risk of missing some item of interest which, in fact, may never turn up. With a facsimile receiver not only can the interesting matter, if any, be picked out by a glance through, but, if it is not convenient to attend at the time of the broadcast, there is no need to do so. This is worth considering in these days of chronic crisis, when there is a tendency for important news to come in at odd hours of the day. A scheme has been proposed for superimposing signals at sub-audible frequencies (i.e., less than 20 c/s) on the programmes for the purpose of switching on suitably adjusted receivers at any time. These signals do not affect the audible (or visible) part of the programme. Of course, part of the receiver has to be active all the time, but it can be a part that costs little to run either in current or valve replacements.

It has even been hinted that it is possible to broadcast sound and facsimile simultaneously on an ordinary broadcasting wavelength, though I have yet to see details of how this apparent miracle is to be accomplished. If it is possible without any serious snags it might bring a facsimile service within the bounds of practicability in our own country, for one of the strongest objections at present is that it ties up valuable channels, to say nothing of power costs. The former, but not the latter, part of this objection is met in America by making it an overnight service.

"Lesdix" Micro-Relay



DEVELOPED from the microammeter which was used in the wide-range valve voltmeter described in our issue of May 4th, 1939, this relay operates with a current of 50 μ A and the contacts will deal with 100-150 mA. Known as the type W/1, this instrument costs £3, and may be obtained from Electradix Radios, 218, Upper Thames Street, E.C.4.

Television Programmes

Sound 41.5 Mc/s.

Vision 45 Mc/s.

An hour's special film transmission intended for demonstration purposes will be given from 11 a.m. to 12 noon each week-day, except during the Test Match. The National or Regional programme will be radiated on 41.5 Mc/s from approximately 7.45 to 9 p.m. daily.

THURSDAY, JUNE 22nd.

3, Mantovani and his Orchestra. 3.30, Gaumont-British News. 3.40-4, 253rd edition of Picture Page, introducing scenes from the Dorchester Floor Show.

5.20-6, London's Welcome to Their Majesties The King and Queen on their return from Canada. Cameras will televise the scenes at Waterloo and outside Buckingham Palace.

9, A Jerome Kern Programme, by Eric Wild and his Band, with Kay Kimber, vocalist. 9.30, British Movietonews. 9.40, Cartoon Film. 9.45-10.15, 254th edition of Picture Page.

FRIDAY, JUNE 23rd.

3-4.30, "Ah! Wilderness," a comedy by Eugene O'Neill. Cast includes Kitty de Legh, Percy Parsons and Joan Miller.

9, Ronald Frankau in Cabaret. 9.35, Gaumont-British News. 9.45, "An Expert in Crime," a play by S. E. Reynolds and Frederick Carlton. 10.20, Cartoon Film. 10.25-10.35, Phyllis Sellick, pianoforte.

SATURDAY, JUNE 24th.

11.30 a.m.-12.30 p.m., The First Test Match, England v. The West Indies. O.B. from Lords with commentary by Thomas Woodroffe.

2.30, Test Match O.B. continued. 3.30, Charles Heslop in "Percy Ponsonby Goes to the Test Match." 3.40, Gaumont-British News. 3.50-4.30, and 6-6.30, Test Match O.B. 9-10.30, "Smoky Cell," the play by Edgar Wallace.

SUNDAY, JUNE 25th.

3-4.30, Jean Murat and Vera Korène in "Le Deuxième Bureau"—Film.

8.50, News. 9.5-10.35, Leon M. Lion and Louise Hampton in "The Silver Box," a play by John Galsworthy.

MONDAY, JUNE 26th.

11.30 a.m.-12.30 p.m., Test Match O.B. from Lords.

2.30, Test Match O.B. continued. 3.30, Eve Lister in Songs, with Evel Burns at the piano. 3.35, Cartoon Film. 3.40, Gaumont-British News. 3.50-4.30, and 5.30-6.30, Test Match O.B. continued.

9, "Television Questionnaire." The Director of Television Explains. 9.10, British Movietonews. 9.20-10.35, "The Curate's Egg"—Revue.

TUESDAY, JUNE 27th.

11.30 a.m.-12.30 p.m., Test Match O.B. from Lords.

2.30, Test Match O.B. continued. 3.30, Cabaret. 4-4.30 and 5.30-6.30, Test Match O.B. continued.

9, Jack Hylton and his Band. 9.30, Gaumont-British News. 9.40, Guest Night. 10.10, Cartoon Film. 10.15-10.25, Charles Heslop in "Percy Ponsonby Goes to the Test Match."

WEDNESDAY, JUNE 28th.

3, "Doctor, My Book," a play by Alicia Ramsay and Rudolph de Cordova, portraying the inventor of the Abernethy biscuit. 3.40, Gaumont-British News. 3.50-4.10, Horace Goldin: Sawing through a Woman!

9, Charles Heslop in "Moonlight 'n' Everything," with Patricia Burke and Edward Cooper. 9.30, Rough Island Story. 9.55, British Movietonews. 10.5-10.35, "In Search of Valour," a comedy by Teresa Deevy.

Precipitation Static

STUDY OF THE CAUSES AND SUGGESTED MEANS OF SUPPRESSION

THE common types of atmospheric static interference due to lightning and inter-cloud discharges are familiar to most wireless listeners, the effect produced being a succession of crashes, crackles and noises of a similar kind. There is, however, another form of atmospheric static which, while less troublesome at ground stations proves a very serious obstacle to wireless reception in aircraft.

It is described as precipitation static and can be recognised, if heard at a ground station, as a combination of frying noises, periods of continuous crackling and a musical sound of varying pitch.

This form of interference can be so severe at times that for hours on end wireless reception is quite impossible and in view of its importance in aerial navigation, especially on the United States air lines, a special study was made of its causes, effects and possible means of suppression. A report on the work carried out so far and the conclusions reached forms the subject of a paper published in the May issue of the *Proceedings of the Institute of Radio Engineers*.

It had hitherto been assumed that precipitation static interference was solely caused by electrically charged particles of rain, snow, sand or dust striking the aerial. As the intensity of the interference resulting from this would depend on the number of particles that hit the aerial every second, aircraft travelling at 200 miles an hour would collect on its aerial a much larger charge than would a stationary aerial at a ground station. Apparent confirmation of this opinion was obtainable since it was possible to reduce the intensity of the interference by lowering the speed,

IN addition to the familiar "atmospherics" there is another form of static that causes severe interference with wireless reception in aircraft. This article deals with the investigations carried out to trace the causes and there is described also an effective means of suppression.

Fig. 2.—Some of the many different kinds of aerial used during the investigation of precipitation static interference.

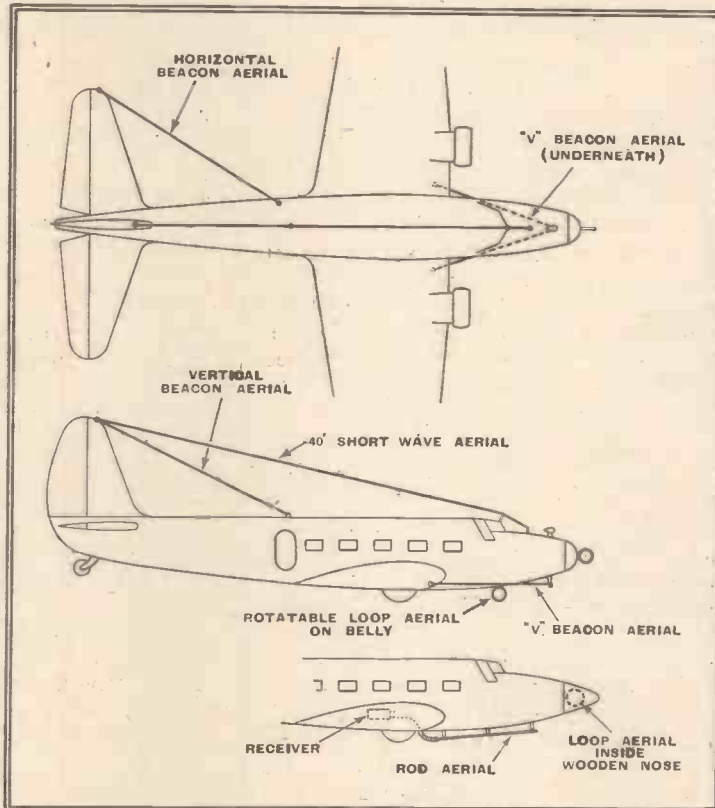

signals were entirely blanketed by interference when using a long wire aerial.

While charged particles can be a cause of precipitation static interference, the investigations revealed that it was not the only cause, as experiments with various kinds of protected aerials gave only partial relief and under severe static conditions practically no advantage at all over the exposed wires.

Pilots had often reported that a phenomenon described as St. Elmo's fire on the tips of the air-screws was generally accompanied by severe radio interference, and this led to a line of investigation that ultimately proved that electrostatic charges on the machine, for most of the aircraft employed for these services are of metal construction or metal covered, was the primary cause.

By connecting a recording meter to a sheet of copper foil attached to the inside of the windscreen of the aircraft the records obtained showed that rain, snow and dust particles striking the windscreen often induced an

electrostatic charge, and that the intensity of the interference heard in the wireless receiver was related to the magnitude of these charges.

From the meteorological data available the primary cause of atmospheric static is

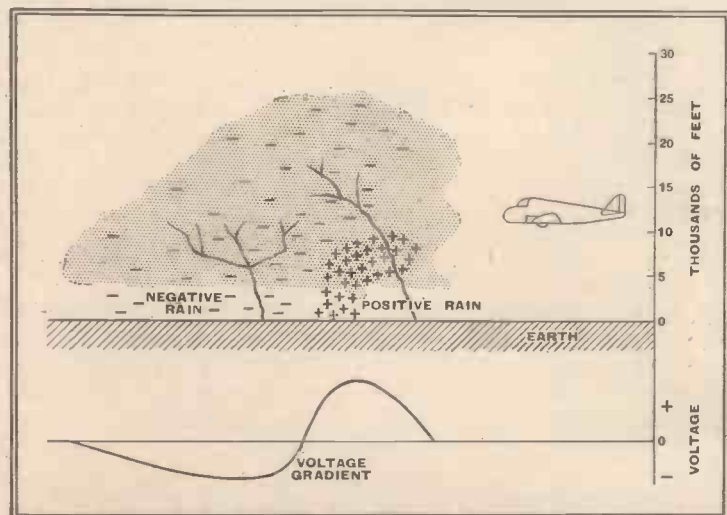

Fig. 1.—Thunder cloud formed by rising currents of warm air showing the distribution of electrical charge and voltage gradient.

In addition, reception on a shielded loop, such as is used for "homing" and direction finding was often possible when

a disturbance in the electrostatic field which surrounds the earth. There is a potential gradient in the atmosphere which varies from about 35 volts per foot of altitude at the surface of the earth to some 3 volts at 20,000 feet, and the potential difference between the earth and the limit of the atmosphere is estimated to be 1,000,000 volts.

Corona Discharges

While the charge remains evenly distributed an aeroplane can fly at a fixed altitude without being troubled by static interference. Any change in height will, however, upset the electrostatic equilibrium between the machine and the surrounding air, which will again not lead to interference if these variations are gradual. With very sudden changes in relative potential the machine will have to dispose of its charge quickly or make good the deficiency as the case may be, and under conditions of this kind corona discharges, similar to the St. Elmo's fire mentioned previously, are often observed. These corona seem to be the principal causes of precipitation static interference to wireless reception on aircraft.

Precipitation Static—

Normally the electric field in the atmosphere is not equally distributed, the disturbing influences being unequal heating by the sun's rays, the formation of cloud containing electrically charged particles of rain and many other causes. Long before the outward manifestation of electrically charged clouds in the form of lightning occurs, the actual potential differences within the cloud itself and through which the aeroplane may be flying can be sufficiently large to set up corona discharges and so produce static interference, the condition required being shown diagrammatically in Fig. 1.

An aircraft flying into a cloud of this kind would first enter an area of positively charged rain and later one negatively charged, and in the sudden transition it would have to dispose of a heavy positive charge into an area of possibly very high negative potential.

Noise Field

Simple charged clouds of this kind do not exist in nature, the actual path of the aircraft would more likely be one of rapidly changing potential differences, thus the interference produced in a wireless receiver would be more in the nature of a continuous irregular noise which is the characteristic form of this kind of interference.

It can quite well be realised that in extensive banks of cloud the machine might

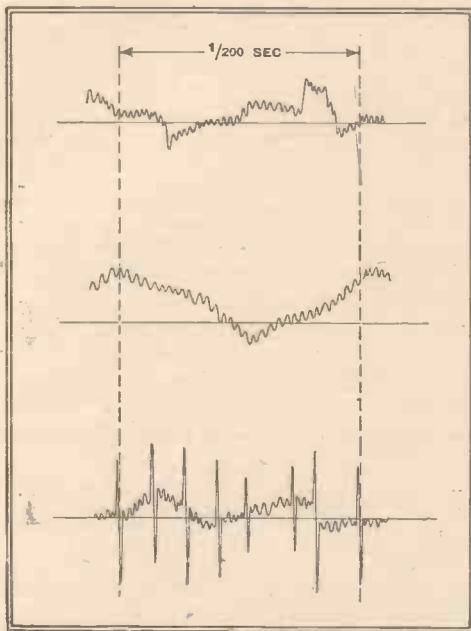

Fig. 3.—The complex waveform of the voltage fluctuations across a 100,000 ohm resistance in series with a steel rod fixed to the tail of the aeroplane are shown by these CR oscillograph patterns.

be subject to these electrostatic charges for long periods on end, thus constituting a serious hazard when reliance has to be placed on navigation by wireless.

In order to ascertain if the placing of aerials would provide a solution tests under all conditions of static interference were made; the positions of some of the aerials used are shown in Fig. 2. In general, it was found that those nearer

the tail of the aircraft gave the poorer signal to noise ratio and that no benefit resulted by using insulated aerial wire. A screened loop in the nose of the machine would often provide a readable signal when with others the signal was swamped by noise and it also indicated that the principal noise area was towards the tail of the machine. The screened loop was not, however, any the less immune from noise pick up under severe conditions of precipitation static.

Further investigation into the theory formulated that electrostatic charges on the machine were the main sources of noise, was carried out by connecting a number of short rods to the tail, on the nose, on each wing tip and to various parts of the fuselage. A study of measurements made of the current flowing in each revealed that at any instant one part of the machine might have a positive charge while another a negative; also that one wing tip could be in a positive field and the other in a negative, with the result that circulating currents actually flowed in the structure.

These transverse or fore and aft currents, though predominantly of a DC nature, had superimposed on them an irregular AC component, this being the responsible factor in the generation of noise.

In Fig. 3 is shown some oscillograph traces of the voltage fluctuations in the steel rod attached to the tail of the machine.

It is on record that while flying in a thundercloud the magnetic compass was deflected some 10 degrees with respect to the gyro-compass and tests on the ground using a storage battery showed that a transverse current from wing tip to wing tip of 45 amperes was necessary to reproduce the same deflection, while one of 125 amperes was needed from nose to tail.

The manner in which a machine in flight acquires an electrostatic charge is extremely complex and very high instantaneous voltages must often be present. In order to reproduce on the ground precipitation static noises comparable to those heard at times in the aircraft wireless receiver while in flight, it was necessary to charge up the machine to 100,000 volts from a Wimshurst disc.

It was concluded that a solution to the

problem could only be found in one of two ways. Either the machine's ability to acquire a charge must be reduced or means must be found to dissipate the charge in a way that would have the least effect on wireless reception.

As the latter seemed the most practical a solution was searched for on these lines.

The corona discharge noise tests indicated that their wavelength was very short

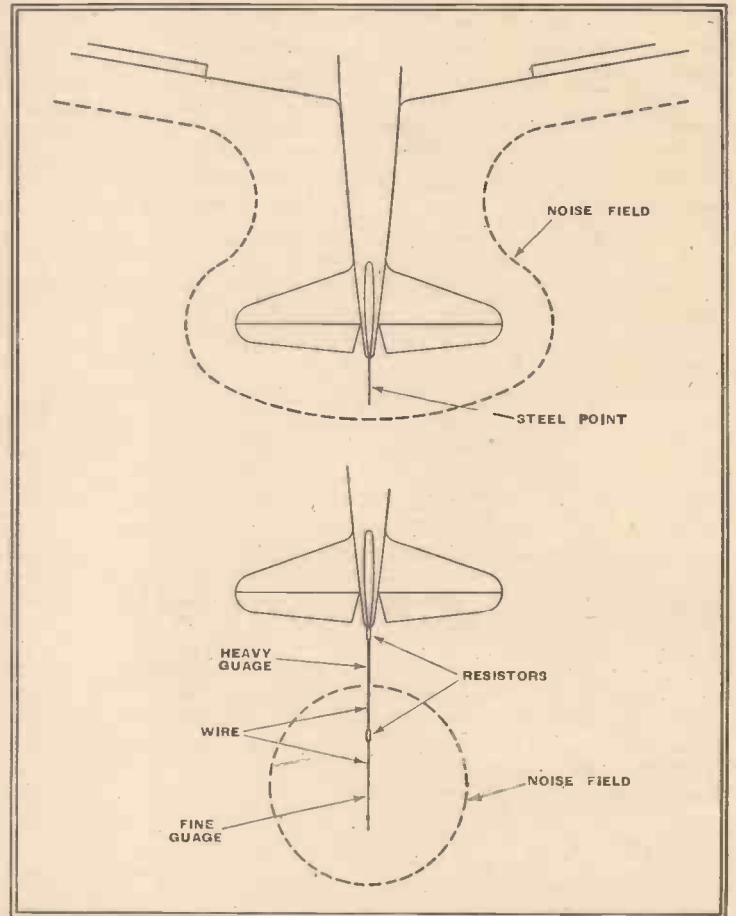

Fig. 4.—Noise field patterns with short and long corona dischargers; the latter is fitted with a suppressor resistance and a thin wire of correct size for the aircraft.

and that rapid attenuation occurred with distance. Taking the tail of the machine as the main concentration of noise a discharge rod was fitted with the idea of moving the corona, which would occur at the end of the rod, some distance from the machine.

A resistance in series with the rod materially reduced the amount of noise experienced during discharge.

Dischargers

Reducing the diameter of the discharge rod and increasing its length also gave an improvement. The noise field patterns at the rear of the test machine with a short discharge rod on the tail, and that which results by employing a trailing wire with resistances in series are shown diagrammatically in Fig. 4.

A practical static noise reducing discharge system is predicted on the basis that the discharge wire or wires must be able to go into corona before any other part of the structure and in order to achieve this its diameter must be smaller than that of any other projection on

Precipitation Static—

the average all-metal aircraft. The fine wire must also be long enough to permit of adequate attenuation of the noise field pattern before it reaches the wireless aerial.

Tests made with discharge wires attached to various parts of the machine showed that a fine wire of five feet in length with a resistance of 100,000 ohms in series was sufficient for most practical purposes. Wing tip dischargers gave very little relief; those towards the rear and on the tail were the most effective. It was estimated that with aircraft of the size used during the tests, a Boeing 247-D all-metal machine and a Douglas DC-3, the dischargers may have to dissipate as much as fifty watts of energy during severe conditions.

During the two years occupied by the tests some of the worst conditions of static interference were encountered and, apart

from quite short periods of a few minutes duration reception of the wireless beacon stations has always been possible since installing a static discharger.

A design suitable for use on commercial aircraft has been evolved and this consists of a cartridge-shaped container in which is carried the discharger wire, a special stainless steel wire of 0.016in. diameter attached to a resistor cord of 100,000 ohms and fitted with a small wind cone to prevent whipping while in flight. Release of the discharger is effected by remote control from the pilot's cockpit, and indicator lamps show when the wire has been ejected.

In the final assembly the discharge cartridges are duplicated but individually operated so that in the event of one being lost in flight a spare is available.

All the illustrations are reproduced from the May issue of the *Proceedings of the Institute of Radio Engineers*.

sion line were used. Horizontal polarisation has been employed at most transmitting stations.

Conditions have admittedly been favourable for long-distance communication on five metres, yet in apportioning the praise one must not overlook the many important improvements made in recent months in amateur ultra-short-wave equipment.

The freer use of CW, better frequency stability in transmitters, well-designed aerial arrays and improved receiving sets, not to mention the larger number of people now taking an active interest in this band, are factors that must also be taken into account. G2MC.

The Wireless Industry

CERTAIN departments of the Tungsram organisation have been transferred from Theobald's Road to an extension of the works premises and all enquiries should now be addressed to British Tungsram Radio Works, Limited, West Road, Tottenham, London, N.17. (Telephone: Tottenham 4884/5/6.)

The Sturdy Electric Company, Limited, manufacturers of transformers to the radio and allied trades has transferred to larger premises at Pontop View, Dipton, Newcastle-on-Tyne.

In Radio Interference Bulletin No. 61 Belling and Lee, Limited, suggest methods of minimising the effects of statistically charged rain. Chlorinated rubber and bituminous paints are among the materials mentioned.

A new catalogue of "Watamps" sound amplifying equipment has been issued by Allied Dynamic Industries, Limited, 303-7, Kingston Road, New Malden, Surrey.

Will Day, Limited, 19, Lisle Street, London, W.C.2, have prepared leaflets describing their Model SR Studio and Model PR Portable recording equipments.

W. A. Davis, A.M.I.W.T., 6, Oxford Street, Newcastle-on-Tyne, is prepared to make up transformers, chokes, etc., for *Wireless World* receiver and amplifier designs.

"Drydex" batteries are now available for the Detrola portable. The H.T. is the type 1160 of 90 volts and the L.T., type 1158, 1½ volts.

Holsun Batteries, Limited, have introduced a 90-volt battery for the new all-battery portables. It consists of two 45-volt units in one block measuring 4½ by 3½ by 5in. The type number is 1485 and the price 9d.

Five-metre DX
EXTRACTS FROM STATION LOGS

IT is now possible to amplify the brief reports of long-distance signals heard on 56 Mc/s during the last week in May and the first in June, and which were included in our last two issues, with extracts from the logs of G5TX, Newport, Isle of Wight, and G6CW Nottingham.

The former contains 23 British and two Continental stations, PAOPN Middleburgh, Holland, and ON4DJ Knocke, Belgium, their respective distances from G5TX being 220 and 190 miles approximately. These are not the most distant stations heard, as the credit for this must go to G3FA, of Newcastle, which is approximately 285 miles from the Isle of Wight.

In addition, G5TX's log includes G2AO, 2MV, 2OD, 2UJ, 2XC, 2ZV, 3YY, 5BY, 5MA, 5MV, 5OJ, 5RD, 5UK, 6CW, 6DH, 6FO, 6OT, 6OU, 6PG, 6XM, 8LY and 8OS.

A Scottish station GM8 ? and a French, F8 ? were also heard but unidentified, in addition to which a host of weak carrier

waves, obviously modulated by speech, were picked up and could have been identified if only the stations had signed off with CW. Possibly some of these might have been well over 400 miles away, as the Scottish station could not be less than 320 miles from G5TX.

Admittedly G5TX has an exceptionally good aerial system and is situated 440 feet above sea level, but the receiver employed is an o-V-1 using ordinary valves.

The most distant station reported by G6CW is G2ZV, near Littlehampton, at 148 miles. Stations worked and heard include G2HQ, 2MC, 2MR, 2MV, 5MA, 5RD, 6DH, 6IH and 6OT. In addition, reports of reception of G6CW have been received from various parts of Sussex, Surrey, Wiltshire and Yorkshire.

G6CW used a 1-V-1 TRF set with acorn RF and detector valves and a small pentode output stage. An elaborate rotatable aerial array having six half-wave elements arranged in phase and a 600-ohms transmis-

HENRY FARRAD'S SOLUTION

(See page 580)

THE part of the circuit diagram shown here reveals that whether the receiver is switched on or off there is a complete circuit discharging the grid bias cells through the LT cell, the valve filaments in parallel (only one shown here), and the bias divider. During the week after the set was installed the grid bias was running down, so that when used thereafter the QPP output valve was receiving practically no bias, instead of being biased nearly to cut off anode current; and the consumption was many times normal. Naturally the reproduction was distorted owing to grid current.

The LT was also discharging, but as the resistance of the bias divider would be arranged to pass a small current compared with the normal LT current this leakage was not noticeable.

When a bias divider is used the battery circuits should be broken by the on/off switch in at least two separate places.

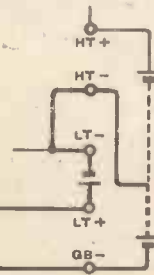

UNBIASED

Pity the Poor Manufacturer

I HAVE just been reading a book on modern psychology by a well-known Harley Street specialist. It starts off rather ponderously by asserting that there is a cause for everything and that nothing can occur without a cause. To me this sort of remark seems self-evident, but apparently it can't be so to everybody, otherwise people wouldn't pay fat fees to Harley Street to tell them of it. From what I can gather from the pages of this book we ought not to be too hard on the engine-driver who passes a railway signal when it is set at danger and thus smashes up the train he is driving; the psychologist's explanation is that in his early days he must have gone out a lot in a car driven by a woman, and so got quite accustomed to ignoring the traffic lights.

The reason why I bring the psychology business up is that it does seem to provide a logical explanation of certain extraordinary things which are occurring every day in our own world of wireless, and in particular makes clear the reason for a rather unfortunate incident that occurred recently in my own household. With the coming of the warm weather Mrs. Free Grid's mind turned momentarily from thoughts of new hats and such-like vanities, and dwelt on the so-called delights of river picnics and other similar horrible functions. Since picnics, river or otherwise, imply gorging yourself with food of a type you dislike at a time when you are not even feeling like eating food you do like, she at once demanded that I buy her a refrigerator, for apparently the advertising men have been busy, and it is considered *de rigueur* nowadays for all picnic food to come out of one of these contraptions.

A large number of radio manufacturers now make other electrical gear apart from wireless sets, and, from a sense of loyalty, I naturally insisted that the order for the



Done to a turn.

refrigerator should be placed with one of these firms. The thing duly arrived, and Mrs. Free Grid, who is rather partial to the pleasures of the table—this being, of course, why she is such ready prey for the slimming advertisers—shoved in a leg of mutton as a little addition to the more

usual hard-boiled eggs and other picnic fare.

All went well until the time came to start out for the picnic, and the refrigerator was opened to get the eatables. To use a popular phrase, the joint was "done to a turn," and the eggs and other things were all piping hot. An investigation on my part revealed the cause of the trouble; the maker of the refrigerator had absent-mindedly put electric cooker elements into the gleaming white case instead of proper refrigerator "works."

Had it not been for my reading the book on psychology which I have already mentioned, I should have been completely at a loss to understand the true cause of what had happened, and might have unjustly blamed the manufacturer. As it is, it is all quite clear to me. The maker of the refrigerator is primarily a wireless manufacturer, and is so used to the old-world radio ritual of supplying two or three models of a receiver before delivering the actual working model that he subconsciously does the same thing when dealing with other electrical apparatus. No doubt when I have received and returned two or three other refrigerators, I shall get the working model and all will be well. Meanwhile, if any of you should happen to get a wireless set which has a vacuum cleaner inside it, or a vacuum cleaner which starts to bring in Luxembourg when switched on, don't write a nasty letter to the manufacturer, but remember that he is probably suffering from what my book calls an "esoteric reflexive complex."

Telinterviews

WE are often told by Americans that we in this country are archaic, degenerate and out of date, and, if certain aspects of our national life are considered, I suppose that these accusations are justified. The London traffic, for instance, is so deplorably slow that many a man taking a bus journey from the Bank to Marble Arch has become a grandfather *en route*; this I can vouch for from personal experience. In other respects, however, notably television, we are far ahead of the Americans, and a special closed-circuit installation, which I was privileged to launch last week—using, of course, a bottle of ether instead of the customary champagne—confirms our lead in this, the most modern, of all branches of applied science.

The installation to which I refer has been designed to meet the particular needs of a well-known business executive who frequently finds it necessary to engage a new secretary, owing to pressure exerted by his wife. He is, unfortunately, of a rather bashful and retiring nature, and in the past he has been easy prey to the first girl he has interviewed, with the somewhat unfortunate result that he has been unjustly accused of engaging his secretaries

By FREE GRID

for their looks rather than for their capabilities.

I have got him out of his difficulties by the simple expedient of getting him to put in a closed-circuit television installation, one end of which is in his room and the other in another part of the building where the applicants for the job are foregathered, there being a separate Emitron for each

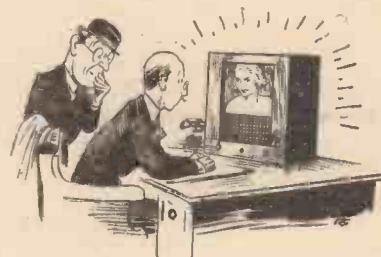

the "fader" is difficult to move.

girl. The beauty of the whole scheme is that if any one of them tends to make him override his better judgment he can quickly fade her out in favour of another, although even so he finds that the personal magnetism touch instilled into the girls by the business colleges is so great in some cases that the "fader" on his receiver is difficult to move. This latter difficulty I hope eventually to overcome by some form of automatic magnetism control.

My friend is so pleased by the success of the scheme that he is getting a similar installation put in at home, so that he can reprimand the cook, when necessary, without having to face the good lady in person. The scheme should have a great future, and I am thinking of floating a company to be called "Telinterviewers, Ltd.," or something like that. Eventually, of course, when all our telephones are fitted with television screens, as will most certainly be the case in the next decade, all interviews of this nature will be conducted by this Televisophone system.

Replies to Correspondents

Ethel (Golder's Green).—Your husband's expressed determination to "improve his scanning arrangements and increase the speed of his flyback" has, I assure you, a purely technical significance, and has no connection with the B.B.C.'s employment of female television announcers.

Eustace (Peckham).—It is perfectly true that a dog scratching himself near a television screen can produce interference just as much as rubbing cats' fur. This has, however, nothing to do with HF "skin effect," nor with the fact that electrical interference is sometimes referred to as "parasitics." With regard to the firm you mention, although their "parasite suppressor" would certainly cure your interference, I cannot see that this justifies their claim to be manufacturers of interference-suppression apparatus.

Random Radiations

Seven Years' Hard

SEVEN years, I've seen it stated, is the average time that a receiving set remains in use to-day before a new one is bought to replace it. I have no means of checking the figure, though from my own observations I shouldn't say that it's far out. If it is correct, it is a sad reflection on the policy of those who manufacture receiving sets. No set, unless it has had so many parts replaced at one time or another that it has to all intents and purposes been rebuilt, can possibly be very reliable or give very good reception after seven years of use. Mechanical parts such as wave-change switches, volume controls and variable condensers would be unlikely to stay the course in a high state of efficiency; and the loud speaker could almost be counted on to show signs (or rather to give audible signs) of wear and tear; we can take it then that a receiver which has had a normal amount of work would be in a rather cranky state some time before seven years are up.

One Reason Why

Then why is its owner so loth to replace it? There can be only one answer to that: Because he does not see good enough reasons for making a change. Very possibly he paid twenty pounds or more for the set. When it was three or four years old he thought about buying a new one, but was astonished and hurt to learn that its part-exchange value was a matter of shillings rather than pounds. And when he came to look at the new sets on offer he didn't find that they were so vastly superior in performance (except, of course, that there was no wobble in their moving parts) to his old friend. They cost a good deal less, but that was to be expected with improved manufacturing methods. Prices, he had noticed, had, in fact, dropped each year; very well; they would be lower still in twelve months' time, and he could quite well make the old receiver do till then. . . .

And Another

There's another point to which the manufacturers have not, I believe, paid sufficient attention. Too often innovations in receiving technique have failed to live up to the resounding fanfares with which they were launched. In most cases the ideas were sound enough; it was in the way in which they were put into practice that the trouble lay. And that trouble was, and to some extent still is, due to the insane policy of making each season's prices lower than those of the previous one. A fine example is Class "B" amplification. This was to give the battery-set user mains volume and quality, whilst actually reducing his running costs. The volume was there and, to some extent, the quality; but running costs were far from being reduced in the medium- and low-priced set, which were sent out with small-capacity H.T.B.s and no room inside them for anything else.

Imitation "De Luxe"

The "all-wave" set is a grand idea, but not if you keep the price down by supplying crude short-wave tuning arrangements and

By "DIALLIST"

omitting sufficient pre-selection to eliminate second channels. The low-priced "all-wave" set made on these lines gave many people the idea that short-wave reception was too uncertain and too difficult to be worth while. Take press-button sets; there are few handier and more generally satisfactory devices for general broadcast reception than the good press-button set. But it isn't much fun to use one that needs re-trimming at intervals, or one whose oscillator drifts so fast and so far that, having "buttoned" a station, you must use the manual control to keep it in resonance if you would avoid distortion. Press-button tuning is most certainly worth having if the receiver is a good one, costing a fair price; but the cheaper sets are the most "boosted" and far more of them are sold. Is it, then, a matter for surprise if the man-in-the-street, hearing reports now here, now there, about shortcomings which he doesn't know are confined to the cheaper sets, forms the opinion that there isn't much in it, after all? I firmly believe that if the attempt to make the cheap receivers pale imitations of luxury models were abandoned both the listener and the radio industry would benefit enormously.

A New Aspect of Television

A FRESH application for television has been discovered by the American General Electric Company. During one of their demonstrations at the New York World's Fair a woman member of the audience who is completely deaf found that she could to some extent follow the words of announcers and other speakers by means of lip-reading. This may open up a wonderful vista for the deaf. To many of them the broadcast wireless programmes are useless, but they might well be able to follow televised talks or even plays, were special care taken by those in the studio to make their lip movements clear and well marked. That is one possible application; Mrs. Sass, the lady in question, at once saw another. She is a business woman, but must now always use an intermediary when she telephones, even if she is speaking from one department to another on the house telephone. With combined vision and telephony apparatus she would need no such help for "inside" calls. There must be many deaf people in important business positions who would gladly avail themselves of such apparatus. As this is only one of

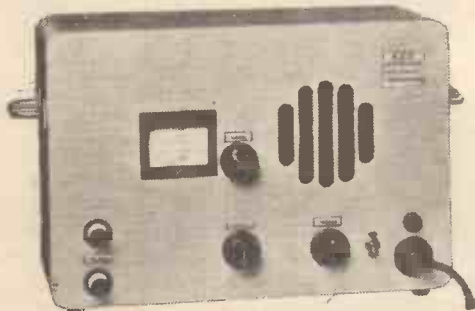

G.E.C. Type M931 Heterodyne Reactance Comparitor.

the many uses to which it might be put, there seems to be a field for the house visio-
phone.

A New W8XAL

W8XAL, the short-wave relay of WLW at Cincinnati, is not one of the most commonly heard American stations with us for, though it is rated at 10 kilowatts, it works on a frequency of 6.06 megacycles and is, therefore, mainly a winter transatlantic. It is possible on certain nights to hear it at this time of year if one is up sufficiently late. Mondays and Thursdays and Saturdays are the most favourable nights, provided that short-wave conditions are good, for then the station is at work right on till daylight the following morning. It is in operation on other nights, but closes down at 12.30 a.m. for some hours. A new W8XAL rated at 50 kilowatts is to be built soon. This station will work on six different channels according to times and seasons. It will broadcast to all parts of the world by means of beam transmissions. WLW's programmes via W8XAL will make a welcome addition to the U.S.A. fare provided for us, for, in addition to many items of its own, the station takes programmes from the National Red, National Blue and Mutual networks.

New G.E.C. Test Instruments

THE G.E.C. Heterodyne Reactance Comparitor and Thermionic Test Set, reference to which was made in our report in this year's Exhibition of the Physical Society, have now been redesigned and put into production.

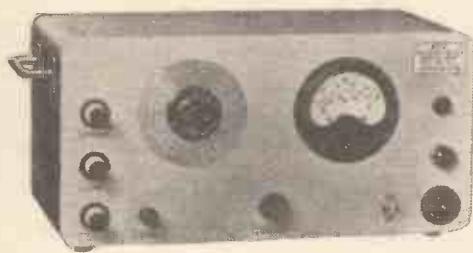

Salford-G.E.C. Thermionic Test Set.

The Heterodyne Comparitor works on the principle of the beat oscillator, and may be used by semi-skilled labour for checking coils and condensers against standards. In practice the instrument is adjusted to zero beat, when any errors may be read on a scale calibrated directly in percentage. The accuracy is 0.1 per cent.

A direct-reading valve voltmeter employing negative feedback is the basis of the Thermionic Test Set, which can be supplied for operation from mains batteries. The input resistance on the AF and DC ranges is 10 megohms. There are nine voltage ranges with maxima from 100 μ V to 1,000 V. DC, and 500 μ V to 500 V. AC. The eighteen current ranges have maxima of 0.01 μ A to 1 A. DC, and 0.05 μ A to 5 A. AC. The frequency range is DC to 20 Mc/s, and the accuracy is \pm 3 per cent.

The instruments are sold through Salford Electrical Instruments, Ltd., Silk Street, Salford, 3, Lancs.

Recent Inventions

CENTIMETRE WAVELENGTHS

FREQUENCIES of the order of 3000 megacycles ($\lambda = 10\text{cm.}$) and above, are generated by a grid-glow discharge tube V, mounted inside a coaxial transmission line T, T_1 , which is tuned to the operating frequency by the resonating effect of the space formed between a metallic disc M

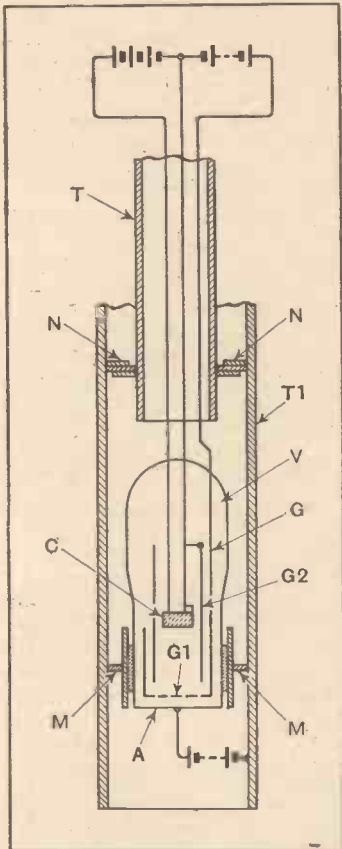

Method of generating ultra-high frequencies.

and a sliding bridge or condenser N.

The discharge tube contains argon gas at a low pressure. This gas is ionised in the space between an indirectly heated cathode C and a biased grid G of cylindrical shape. At the end of the grid is a perforated disc G1, which is separated from the anode A by a distance less than the mean free path of the ionised gas molecules.

A screening grid G2 confines the discharge to paths near the perforated disc G1. Owing to the close spacing between the disc and the anode A, oscillations are generated as though no gas were present, the short transit time of

Brief descriptions of the more interesting radio devices and improvements issued as patents will be included in this section.

the electrons favouring the production of very high frequencies. *Standard Telephones and Cables, Ltd. (assignées of C. A. Bieling). Convention date (U.S.A.) November 20th, 1936. No. 500755.*

SCANNING SYSTEMS

A CATHODE-RAY tube for use in television is provided with two or more permanent magnets located between the deflecting plates and the fluorescent or other target screen. The magnets produce a control field at an angle of 50 degrees to the path of the electron stream, and this is applied to increase the deflection of the stream so as to enlarge, say, the picture width, without otherwise affecting the pattern produced on the screen.

The object is to allow the use of scanning voltages of lower amplitude than usual on the deflecting plates, so that a more accurate "saw-toothed" formation can be obtained.

Hazeltine Corpn. (assignées of M. Cawein). Convention date (U.S.A.), December 24th, 1936. No. 500502.

AUTOMATIC SELECTIVITY CONTROL

THE IF amplifying valve V of a superhet receiver is arranged to develop a separate or independent voltage for automatic selectivity control. The two halves of a screening grid SG surround a gain-control grid G and an auxiliary anode A1. The latter traps some of the discharge current, and feeds it back to a resistance-capacity shunt R C placed across the primary of the coupling trans-

former T. The effect is to tighten or loosen the coupling, and so regulate the selectivity of the set.

When the incoming signals are weak, the AVC voltage on the grid G is at a minimum, and most of the electron stream passes to the main anode A, and then, via the second detector stage D, to the loud speaker LS. Very few electrons are intercepted by the auxiliary anode A1, so that there is comparatively little energy fed back to the shunt circuit R C. Selectivity is then high.

In the case of stronger signals, the AVC voltage on the grid G increases, and more of the discharge stream is therefore intercepted by the auxiliary anode A1. This results in a larger current being fed back to the phase-shifting shunt R C, so tightening the coupling of the transformer T, and increasing the width of the accepted sidebands.

The British Thomson-Houston Co., Ltd. Convention date, (U.S.A.), October 22nd, 1936. No. 500818.

POSITION-FINDERS

THE position of an aeroplane in flight is shown by the intersection of two pointers over a chart mounted on the dashboard of the machine. Each pointer is controlled by a separate frame aerial which is kept constantly rotating by a motor, each aerial being tuned to a different beacon transmitter.

A flexible drive connects the shaft of each frame aerial to its associated pointer, through a relay which is operated by the signal pick-up from each aerial, so that the pointer is driven to one side

or other until it takes up a position corresponding to "minimum" pick-up on the aerial, whereupon it remains stationary. The second pointer is similarly controlled by the other aerial, so that the intersection of the two pointers gives the pilot a "fix" of his position on the chart relative to the two distant beacon transmitters.

O. G. E. Roberts. Application date July 21st, 1937. No. 499383.

FACILITATING PROGRAMME CHOICE

THE figure shows a fitting added to a wireless set for holding a synopsis of the day's programmes conveniently in view. The programme sheet is placed in a holder P, which can be inclined at any desired angle to the vertical. When not required, the holder P can be folded back into

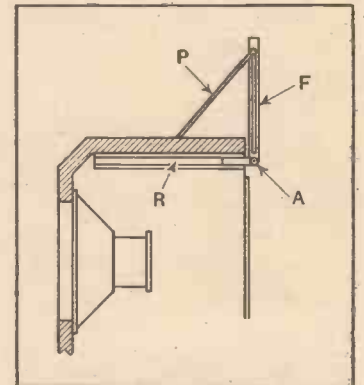

Device for holding radio programmes.

a frame F, and the whole fitting pushed out of sight into a recess R below the top of the cabinet. The frame is pivoted at A and slides in and out on guide rails.

A. Schwarzwald. Application date January 17th, 1938. No. 500762.

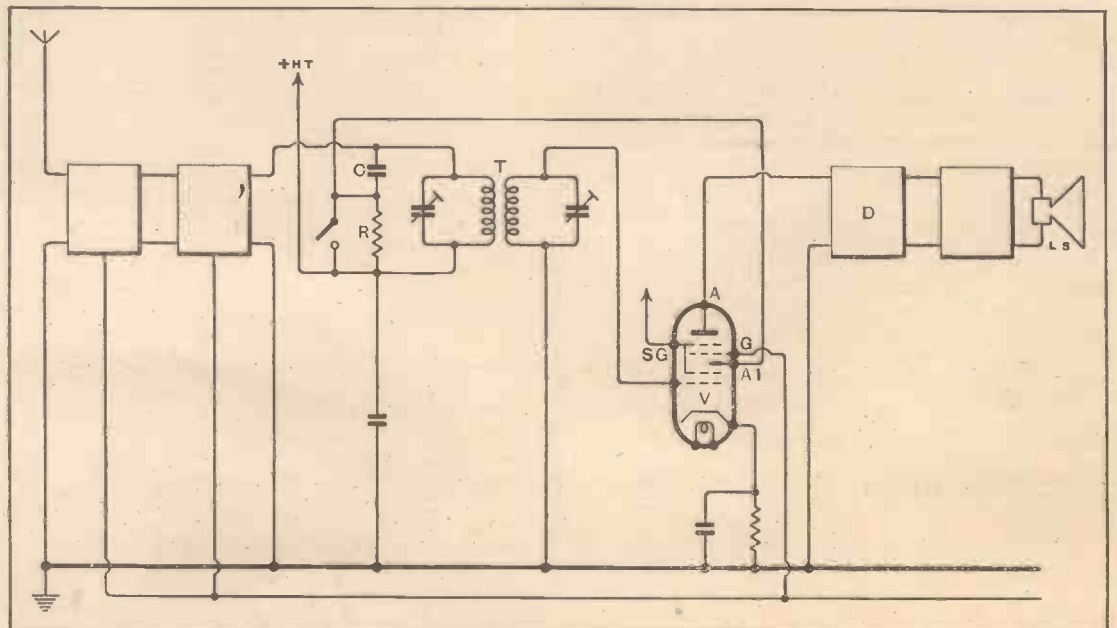

Circuit arrangement for correlating signal strength and selectivity.

The British abstracts published here are prepared with the permission of the Controller of H.M. Stationery Office, from specifications obtainable at the Patent Office, 25, Southampton Buildings, London, W.C.2, price 1/- each.

'HIGH FIDELITY'—

and its achievement!

above can be almost entirely eliminated. It is fairly obvious that if we start with a strip which in its quiescent condition, is already curved, pressure applied unilaterally to one end will only tend to increase and decrease the amount of curvature. For the centre cone curvature of comparatively small radius is necessary, whereas only a slight curvature is used in the main diaphragm, where such harmonics are not likely to be troublesome, due to the fact that the main diaphragm is only used to reproduce the lower frequencies.

Another very desirable feature of the curved diaphragm is owing to its increased radial rigidity, thinner material may be used than that of a flat diaphragm.



The ATTAINMENT OF AN IDEAL

GOODMANS LOUSPEAKERS

transmits a clear, crisp transient response. Loudspeakers simultaneous

5. Elimination of Bass modulation of the upper frequencies.

Bass modulation of the upper frequencies is the cause of a very unpleasant form of distortion which manifests itself as a ripple superimposed on high notes, giving a "warbled" tone to the reproduction. This is caused by the voice coil, during its axial travel at a low frequency (where the movement is at a maximum) cutting a magnetic field of varying intensity. Assuming the coil starts to move, some of the turns will pass outside the field, or at least into a field of very much lower flux density. Since the driving force exerted by the coil on the diaphragm is the product of the flux and current, a reduction in the flux means a reduction in the driving force. Take for example, a 50 c.p.s. note with a 100 c.p.s. tone superimposed. During one half cycle of the 50 c.p.s. vibration the voice coil, starting from the centre of the gap, or in other words through a phase angle of 180°, the result will be 1,000 = 10 complete cycles of the 100 c.p.s. note.

But each cycle will be gradually decreasing to a minimum then increasing in intensity from the previous cycle, so that instead of reproducing a steady note at 100 c.p.s. we have a note with its intensity varying at the rate of 100 c.p.s. This may be remedied either by arranging that the coil is very much longer than the gap, or that the gap is very much longer than the coil. In the first case a similar number of turns of wire is always in the gap, which in the second the coil is operating in a field of constant strength since the coil does not travel beyond the end of the gap. Both these methods cause a diminution in sensitivity but owing to the greater axial length of gap required to supply the method a much larger magnetic system is required to supply the increased total flux. In GOODMANS "High Fidelity" Loudspeaker method a much larger magnetic system is required to supply the increased total flux. It has generally been presumed that energized Moving Coil Loudspeakers are superior to Permanent Magnet types. The question of flux density is governed by the amount of magnetic material employed. First to the introduction of special alloys it would have been necessary to employ enormous magnets at prohibitive prices in order to obtain flux densities approaching those obtained by energized loudspeakers.

6. Freedom from Hum.

In designing these High Fidelity Loudspeakers it was decided to fit Permanent Magnets, provided flux densities, at least equal to

AN AUTHORITATIVE 20-Page BROCHURE—YOURS FOR THIS COUPON

This Brochure, acclaimed by the technical press as the most informative of its kind, describes the problems met with in the quest for "high fidelity" reproduction. The difficulties encountered in the attainment of level response, wide frequency range, and the reduction of sub-harmonics, etc., are fully described, together with the results of many tests and methods employed to overcome these difficulties.

This Brochure, of valuable technical data on the fundamental principles of loudspeaker design and with typical response curves, will be sent to you on receipt of the coupon below. Post it now!

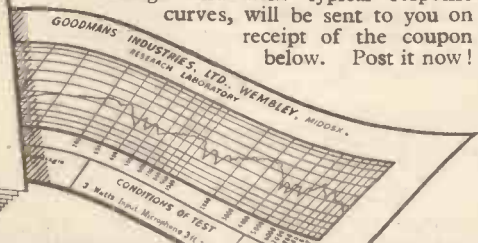

GOODMANS INDUSTRIES, LTD.

To GOODMANS INDUSTRIES LTD., Lancelot Road, Wembley, Mdx. Phone: Wembley 4001-5. Please send me a copy of your Technical Brochure—"The Attainment of an Ideal." I enclose 1/4d. stamp.

NAME..... ADDRESS..... W.W.22.6.39. Attach this to your card or letter heading.

POST THIS COUPON NOW



LEARNING MORSE

AN EASY METHOD OF MASTERING THE INTERNATIONAL SIGNAL CODE

Published from the Offices of **The Wireless World** 6^D NET BY POST 7d. W.W.94

THE

WIRELESS ENGINEER

The Journal for Professional Engineers and Advanced Wireless Experimenters

Monthly 2/6 net. Annual Subscription 32/- post free. ILIFFE & SONS LTD., Dorset House, Stamford St., London, S.E.1

W.W.2.

Mention of "The Wireless World," when writing to advertisers, will ensure prompt attention.



SOUND AMPLIFYING EQUIPMENT

Rack and Panel or Portable Equipments to suit particular requirements

AMPLIFIERS—Units of 10 to 120 watts undistorted output. (Volume expansion and contraction when required).

MICROPHONES—Carbon, Ribbon, or Moving Coll.

SPEAKERS—

Indoor:— 6 ins. to 10 ins. Cone P.M. units. Outdoor:— 3 ft. and 6 ft. Horns; metal diaphragm units.

When sending in your enquiries, please state approximate area to be served, and power supply.

To Sound Reproducer Sales—

BTH RUGBY

THE BRITISH THOMSON-HOUSTON COMPANY LIMITED, RUGBY, ENGLAND A2710N

CLASSIFIED ADVERTISEMENTS

NOTICES

THE CHARGE FOR ADVERTISEMENTS in these columns is

12 words or less, 3/- and 3d. for every additional word.

Each paragraph is charged separately and name and address must be counted.

SERIES DISCOUNTS are allowed to Trade Advertisers as follows on orders for consecutive insertions, provided a contract is placed in advance, and in the absence of fresh instructions the entire "copy" is repeated from the previous issue: 13 consecutive insertions 5%, 26 consecutive, 10%; 52 consecutive, 15%.

ADVERTISEMENTS for these columns are accepted up to **FIRST POST ON MONDAY MORNING** (previous to date of issue) at the Head Offices of "The Wireless World," Dorset House, Stamford Street, London, S.E.1, or on **SATURDAY MORNING** at the Branch Offices, 8-10, Corporation Street, Coventry; Guildhall Buildings, Navigation Street, Birmingham, 2; 260, Deansgate, Manchester, 3; 26a, Renfield Street, Glasgow, C.2.

Advertisements that arrive too late for a particular issue will automatically be inserted in the following issue unless accompanied by instructions to the contrary. All advertisements in this section must be strictly prepaid.

The proprietors retain the right to refuse or withdraw advertisements at their discretion.

Postal Orders and Cheques sent in payment for advertisements should be made **& Co.** payable to **ILIFFE & SONS Ltd.**, and crossed **Notes being untraceable if lost in transit should not be sent as remittances.**

All letters relating to advertisements should quote the number which is printed at the end of each advertisement and the date of the issue in which it appeared.

The proprietors are not responsible for clerical or printers' errors, although every care is taken to avoid mistakes.

ARMSTRONG'S NEW HEADQUARTERS



Like our new Headquarters, Armstrong Chassis have a strong foundation and are built by experienced workmen from the best quality material.

During the past seven years "Wireless World" readers have proved their quality and reliability. If you've not heard one, why not call when next in Town?

From Mondays to Fridays we are demonstrating until 7.30 p.m. and on Saturdays an Engineer is in attendance until 5.30 p.m. for the convenience of customers who cannot call during the week. In the meantime send for our Illustrated Catalogue which includes the following outstanding models.

MODEL RF96 Price £8.0.0

6-V. ALL-WAVE RADIOGRAM CHASSIS Complete with Matched M.C. Speaker.

Incorporating R.F. Amplifier, 3 wavebands, 17.9-50, 200-550, 1,000-2,000 m., 3 stages of A.V.C., corrected 3½ watts output.

MODEL AW93PP . . . Price £10.10.0

9-V. ALL-WAVE RADIOGRAM CHASSIS 3 wavebands, R.F. Pre-Amplifier, 3 stages of A.V.C. and 8 watts R.C. coupled Triode P.P. output.

MODEL AW125PP . . Price £17.17.0

12-V. ALL-WAVE RADIOGRAM CHASSIS 5 wavebands, 12-550 continuous, 1,000-2,000 m., R.F. Pre-Amplifier, 2 I.F. stages with Variable Selectivity, Manual R.F. gain control and 10 watts R.C. coupled Triode P.P. output.

ARMSTRONG MANUFACTURING CO., WALTERS ROAD, HOLLOWAY, LONDON, N.7 (Adjoining Holloway Arcade).

Telephone: NORTH 3213.

NUMBERED ADDRESSES

For the convenience of private advertisers, letters may be addressed to numbers at "The Wireless World" Office. When this is desired, the sum of 6d. to defray the cost of registration and to cover postage on replies must be added to the advertisement charge, which must include the words Box 000, c/o "The Wireless World." All replies should be addressed to the Box number shown in the advertisement, c/o "The Wireless World," Dorset House, Stamford Street, London, S.E.1. Readers who reply to Box No. advertisements are warned against sending remittances through the post except in registered envelopes: in all such cases the use of the Deposit System is recommended, and the envelope should be clearly marked "Deposit Department."

DEPOSIT SYSTEM

Readers who hesitate to send money to advertisers in these columns may deal in perfect safety by availing themselves of our Deposit System. If the money be deposited with "The Wireless World," both parties are advised of its receipt.

The time allowed for decision is three days, counting from receipt of goods, after which period, if buyer decides not to retain goods, they must be returned to sender. If a sale is effected, buyer instructs us to remit amount to seller, but if not, seller instructs us to remit amount to depositor. Carriage is paid by the buyer, but in the event of no sale, and subject to there being no different arrangement between buyer and seller, each pays carriage one way. The seller takes the risk of loss or damage in transit, for which we take no responsibility. For all transactions up to £10, a deposit fee of 1/- is charged; on transactions over £10 and under £50, the fee is 2/6; over £50, 5/-. All deposit matters are dealt with at Dorset House, Stamford Street, London, S.E.1, and cheques and money orders should be made payable to Iliffe & Sons Limited.

SPECIAL NOTE—Readers who reply to advertisements and receive no answer to their enquiries are requested to regard the silence as an indication that the goods advertised have already been disposed of. Advertisers often receive so many enquiries that it is quite impossible to reply to each one by post. When sending remittances direct to an advertiser, stamp for return should also be included for use in the event of the application proving unsuccessful.

NEW RECEIVERS AND AMPLIFIERS

R.

RADIO CLEARANCE, Ltd.

63, High Holborn, W.C.1. Phone: Holborn 4631.

GUTHMAN MC Murdo Silver Communication Receiver.

WE are Sole Distributors for the United Kingdom of Above Product.

CIRCUIT Superhet, with double regeneration obtained at signal frequency and also at intermediate frequency. As a result, very high sensitivity and selectivity are obtained.

CONTROLS—R. meter, silencer, tone, aerial trimmer, A.F. gain, selectivity, beat oscillator, receiver-send A.V.C. B.O. on/off; assembled with valves but unwired. £17; wired and aerial test'd, £18/18.

ROTHERMEL Piezo High Fidelity Speakers.

MODEL R.95, 7in. cone, will handle 5 watts; 9/11.

MODEL R105, 10½in. cone, will handle 6 watts; 11/6.

ABOVE can be Used in Conjunction with Existing Moving Coil Speaker, connect across primary of speech transformer; to use independently a choke must be connected between the receiver or amplifier output; in the event of push-pull connect to the 2 anode terminals of output transformer, ignoring C.T.

T.C.C. 8 mfd. 450-volt Working Wet Electrolytics, can type, 1 hole fixing; 1/6 each.

POLAR ½ and ¼ Resistances, good selection; 4/6 a gross.

PHILCO American Mains Transformers.—200-250-volt, 6.3-volt 3 amp., 5-volt 2-amp.; 7/6 each.

BRITISH Belmont.

RECEIVERS and Chassis Still Available from Stock; as previously supplied.

RECEIVERS, with valves; £7/7.

CHASSIS, with valves; £5/19/6.

ALL Lines Previously Advertised Still in Stock.

ALL Orders Over 5/- Carriage Free; under this amount sufficient postage must be included with order.

ALL Enquiries Must Enclose 1½d. Stamp.

RADIO CLEARANCE, Ltd., 63, High Holborn, W.C.1. Telephone: Holborn 4631. [8593]

NEW RECEIVERS AND AMPLIFIERS

* DEGALLIER'S "Challenge Radio Corporation."

SEND 2d. stamp for Handsome Illustrated Catalogues Telling of our Superb Range of Receivers; direct public sales policy (saves you 40%), most exceptional value on the market, from a T.R.F. Midget at £3/5 to a 19-valve general purpose receiver, 6 bands, with two P.A. speakers, at 30 gns. 6-page brochure of Wireless World report on this set is available; car radio; any known American valve, all 5/6 each; also American P.A. speakers, cabinets, and the Challenger 6-valve A.C. tuning unit, 5 bands 6-10, 12.8-50, 65-200, 150-550, 900-2,000 metres. Hours business 11 a.m. until 9.30 p.m.

DEGALLIER'S, 31, Craven Terrace, London, W.2. Paddington 6492. Nearest point Lancaster Gate Tube Station. [8515]

ARMSTRONG Co.—After many years at our old premises at Camden Town we have removed to a new building in Walters Rd., Holloway, N.7 (see displayed advertisement).

ARMSTRONG Amplifier Division Has Moved to New Premises at 94, Camden Rd., N.W.1. Enquiries for High Fidelity amplifiers and simple feeder units should be made to this address. Catalogue of this apparatus will be forwarded free to those interested.

ARMSTRONG Co. (Amplifier Division), 94, Camden Rd., N.W.1. [8518]

USED SETS FOR SALE

MISCELLANEOUS

A NUMBER of Reconditioned Sets in Good Order; from £5 upwards—Halford Radio, 31, St. George St., W.1. [0617]

Wanted

Q.A. Super Receivers Only, "Wireless World," 28/2/1936. Box 192, c/o The Wireless World. [8600]

CAR RADIO

1939 Models from 4½ gns.; 6 new car aeriels, from 9/6; trade enquiries solicited; lists free.—Shippers, 18, Corporation St., Manchester. [0622]

FINEST American Twin Running-board, Aeriels, completely rubber covered, maximum signal pick-up, minimum noise, easy mounting, now only 17/6 pair complete; handsome chromium roof aeriels, to mount straight or "vee," complete, 15/-; immediate despatch, carriage paid; cash with order or c.o.d.

WIRELESS SUPPLIES UNLIMITED, Essex House, Stratford, E.15. Maryland 3191. [0577]

PUBLIC ADDRESS

PUBLIC Address Contractors Can Hire P.A. Vans, loud speakers, microphones and equipments of all types from Hire Dept., Gramplan Reproducers, Ltd., Kew Gardens, Surrey. Tel.: Richmond 1175-6-7. [0618]

For PROMPT DELIVERY
of High Quality

LOUDSPEAKERS, LOUD-
SPEAKER CONES, LOUD-
SPEAKER COMPONENTS,
TRANSFORMER LAMINATIONS,
TRANSFORMER HOUSINGS,
TRANSFORMER WINDINGS,
CHOKE WINDINGS, FIELD
COIL WINDINGS, PERMANENT
MAGNETS, PRESS TOOLS AND
PRESSINGS, JIG BORING,
AUTOMATIC SCREW MACHINE
PARTS UP TO 2" DIAMETER.

Call on
BRITISH ROLA LTD.

MINERVA ROAD, PARK ROYAL, N.W.10.
'PHONE: WILLESDEN 4322-3-4-5-6

Contractors to the Admiralty, War Office and Air Ministry.

PUBLIC ADDRESS

VORTEXION P.A. Equipment.
IMITATED, but unequalled.
WE Invite You to a Demonstration.
A.C.-D.C. Dance Band Amplifier, 10 watts output, complete in case, with moving coil microphone, speaker and cables. weight 22lb.; 12 gns.
A.C.-20 15-20 watt Amplifier, 38-18,000 cycles, independent mike and gram., inputs and controls, 0.037 volts required to full load, output for 4, 7.5, and 15 ohms speakers or to specification, inaudible hum level; ready for use; 8½ gns., complete.
C.P. 20 12-volt battery and A.C. Mains Model, as used by R.A.F., output as above; 12 gns.
A.C.-20, in portable case, with Collaro motor, Piezo pick-up, etc., £14; C.P.20 ditto, £17/17.
50-WATT Output 6L6s, under 60-watt conditions, with negative feed back, separate rectifiers for anode screen and bias, with better than 4% regulation, level response, 20-25,000 cycles, excellent driver, driver transformer, and output transformer matching 2-30 ohms impedance electronic mixing for mike and pick-up, with tone control, complete with valves and plugs; £15.
COMPLETE in Case, with turntable B.T.H. Piezo pick-up and shielded microphone transformer; £20.
80-WATT Model, with negative feed back; £25, complete.
120-WATT Model, with negative feed back; £40, complete.
250-VOLT 250 m.a. Full Wave Speaker, field supply unit; 25/-, with valve.
ALL P.A. Accessories in Stock; trade supplied.
VORTEXION, Ltd., 182, The Broadway, Wimbledon, S.W.19. Phone: Lib. 2814. [8241]

SPECIAL Sale of Demonstration Sound Equipment.
8 Watt Universal Amplifier, complete with valves; £4.
20 Watt A.C. Amplifier, complete with valves, input for 2 microphones, and pick-up electronic mixer panel; £10.
40 Watt A.C. Amplifier, complete with valves, input for 2 microphones, and pick-up electronic mixer panel; £14.
8 Watt A.C./D.C. and Battery Operated Public Address Equipment, complete in one case with gramophone turn table, microphone and two horn speakers; £20.
16 Watt A.C./D.C. and Battery Operated Public Address Equipment, complete in one case with gramophone turn table, microphone and two horn speakers; £22/10.
20-25 Watts A.C. Public Address Equipment, complete in one case with gramophone turn table, microphone and two horn speakers; £24.
40 Watt A.C. Public Address Equipment, complete in one case with gramophone turn table, microphone and two horn speakers; £33.
SELMER; 114, Charing Cross Rd., London, W.C.2. [8598]

"PARTRIDGE P.A. Manual," standard handbook on electro-acoustics, amplifiers, and audio circuits; price 2/6 (free to trade).
"PARTRIDGE Amplifier Circuits," describes many modern constructional amplifiers, 2w. to 45w. output, battery, A.C.-D.C., etc.; price 2/- (no free copies).
PARTRIDGE, N., B.Sc., A.M.I.E.E., King's Buildings, Dean Stanley St., London, S.W.1. [0630]
QUALITY Amplifiers and Microphone Equipments for Hire or Permanent Installation.—Harmony House, 116, Cambridge Rd., Southport. [8505]
ALEXANDER BLACK, Ltd., Established 1925.—For microphone equipment when quality counts. Booklet on request.—55, Ebury St., S.W.1. Sloane 6129. [0596]

NEW MAINS EQUIPMENT

V. ALL Transformers at Last Week's Prices.
VORTEXION, Ltd., 182, The Broadway, Wimbledon, S.W.19. Phone: Lib. 2814. [8611]

NEW LOUD-SPEAKERS

SINCLAIR Speakers for All Types.—Alma Grove, Copenhagen St., N.1. [0603]
SAVE Pounds.—1¼d. stamp for list British and American P.A. Speakers.—Degallier's, 31, Craven Terrace, London, W.2. [8554]
BAKERS New Corner Horn Speakers, Triple cone conversions; from 29/6, and surplus speaker bargains.—Bakers Selhurst Radio, 75, Sussex Rd., South Croaydon. [8608]

LOUD-SPEAKERS

SECOND-HAND, CLEARANCE, SURPLUS, ETC.
VAUXHALL UTILITIES, 163a, Strand, W.C.2.—Rola G.12 P.M. speakers, 62/6; G.12 energised, 50/-; Rola 8in. P.M., 14/9; all brand new with transformers. [8609]
3,000 Speakers from 5/6 each, P.M. and energised, 4in. to 14in., including several Epoch 18in.—Sinclair Speakers, Alma Grove, Copenhagen St., N.1. [0591]

Wanted

WANTED, Hartley-Turner speaker, permanent magnet or duode.—Beasley, Tilm Lane, Retford. [8604]

ERIC Insulated RESISTORS

Cannot break down!

That's why set manufacturers use them!
 Now let us explain why you should always use Erie. The strong Ceramic Insulating Tube will stand up to 3,000 volts A.C. The ends are sealed for protection against moisture, ensuring a perfect mechanical and electrical junction and the connecting wires will take a 12 lb. pull. All resistors are rationally rated and are guaranteed to carry 50% overload with less than 4% maximum resistance change—even then they will not break down.

Exhaustive tests show exceedingly low voltage co-efficient. For example, a 1,000 ohm ½ watt resistor changes but .002% per volt, a 10,000 ohm unit drops only .0041% per volt, 100,000 ohm changes .0076% per volt and a 1 megohm unit .011% per volt. Erie Insulated Resistors give uniformly superior results in all standard tests for load, temperature, voltage, humidity and noise. They are compact and safe. No possibility of shorts and earths even in the smallest installation spaces. Numerous tests are made during the process of manufacture and finally every Resistor is INDIVIDUALLY HAND TESTED.

CARBON RESISTORS

RMA9.	½ watt ± 10%.	Insulated	...	3d. each
RMA8.	1 watt ± 10%.	Insulated	...	6d. each
RMA2.	2 watt ± 10%.	Non-insulated	...	1/- each
RMA1.	3 watt ± 10%.	Non-insulated	...	1/6 each
RMA0.	5 watt ± 10%.	Non-insulated	...	2/6 each

The following Erie Products are as reliable as our Resistors:

TONE & VOLUME CONTROLS

Less Switch	...	2/6 each
With Single-Pole Switch	...	3/- each
With Double-Pole Switch	...	3/6 each
Centre Tapped with Switch	...	4/6 each

Non-standard spindles 6d. per control extra.

DUAL & GANGED CONTROLS

Less Switch	...	4/6 each
With Single-Pole Switch	...	5/- each
With Double-Pole Switch	...	5/6 each

FOR DEALERS AND SERVICE ENGINEERS

★ ERIE RESISTOR KITS



For efficiency and economy you should have your resistor stock in handy cabinet form. No losses—No waste—Easy to find. We give you the cabinet. You pay only for the resistors, which are an assortment of the most used values.

All these Resistors are RMA Colour Coded Tolerance. + or - 10%.
 KIT I R 48. 48 One-Watt Resistors. List price 24/- in FREE Pressed-steel box.
 KIT I R 96. 96 Half-Watt Resistors. List price 24/- in FREE Pressed-steel box.
 KIT I R 100. 100 One-Watt Resistors. List price 50/- in FREE Strong board Cabinet, 8 partitioned drawers.
 KIT I R 200. 200 Half-Watt Resistors. List price 50/- in FREE Strong board Cabinet, 8 partitioned drawers. Subject to usual Trade Discount.

The range of ERIE PRODUCTS includes:

Volume Controls, Tone Controls, Vitreous Wire-wound Power Resistors, Ceramicon-Midget Fixed Condensers, Silver Mica Condensers, Car Radio Suppressors, High Voltage Resistors.

Send to-day for full details

ERIE RESISTOR LTD.

CARLISLE RD., THE HYDE, HENDON, N.W.9
 Telephone: Colindale 8011

TRADE COUPON

To Erie Resistor Ltd., Carlisle Road, Hendon, N.W.9.

Please send details of your RESISTOR KITS, CONTROLS, SUPPRESSORS, etc., and trade terms.

ATTACH THIS TO YOUR BUSINESS CARD W 22/6

LOUD-SPEAKER CONVERSIONS

EPOCH Domino Loudspeakers Can Now be Converted to the Famous "NEW" Super Cinema Speaker with 14in. Cone, replacement for all Epoch speakers, also output transformers; a genuine Epoch hand-made cone for any speaker.

HALFORD DISTRIBUTORS, Ltd., 31, St. George St., W.1.—Sole manufacturers of Epoch loudspeakers and the famous Halford Phantom radio set. [0632]

TRANSMITTING APPARATUS

A.C.S. RADIO, specialists in short-wave apparatus, communication receivers, including Hallicrafters, National and R.M.E. transmitting equipment, valves and components.—Send for free catalogue to A.C.S. Radio, 16, Gray's Inn Rd., W.C.1. Holborn 9894-5. G2NK, Technical Manager. [0550]

G5NI—The oldest and largest distributor of amateur equipment, transmitting and receiving; short-wave catalogue, 1¼d.; G5NI 70-page Manual, 7½d., post free; authorised direct distributor for Collins, National, R.M.E., Thordarson, Hammerlund, Biley, Taylor, Eimac, etc., etc.—44, Holloway Head, Birmingham. [0531]

CABINETS

A CABINET for Every Radio Purpose.
CONVERT Your Set into a Radiogram at Minimum Cost; surplus cabinets from noted makers under cost of manufacture (undrilled); 30/- upwards; motors at wholesale prices.
"FIT-A-GRAM" Cabinet, 31' x 17' x 15'; 21/-.

UNDRILLED Table Console and Loud-speaker Cabinets from 3/6.
INSPECTION Invited; photos loaned to country customers.

H. L. SMITH and Co., Ltd., 289, Edgware Rd., W.2. Tel.: Pad. 5891. [0485]

CLEARANCE Sale!!—Radiogram and television cabinets, prices slashed! 10 gns. worth for 50/- 5 gns. worth for 20/-—Write, wire, 'phone or call, Cameo Co., 23, Denmark St., W.C.2. (Tel. 5900.) [8527]

DEGALLIER'S for the Finest Obtainable American Cabinets, Table, Console and Radio Grams; also Record Changers, 5 gns. Send 1½d. stamp for reprints from actual photographs.—Degallier's 31, Craven Terrace, Lancaster Gate, London, W.2. [8553]

DYNAMOS, MOTORS, ETC.

D.C.-A.C. Convertors, motors, all voltages, for sale and wanted.—Easco, 18w, Brixton Rd., S.W.9. [0558]

ALL Types of Rotary Convertors, electric motors, battery chargers, petrol-electric generator sets, etc., in stock, new and second-hand.

A.C.-D.C. Conversion Units for Operating D.C. Receivers from A.C. Mains, 100 watts output, £2/10; 150 watts output, £3/10.

WARD, 46, Farringdon St., London, E.C.4. Tel.: Holborn 9703. [0518]

RECORDING EQUIPMENT

WANTED—V.G. tracker and head, also motor.—Box 159, c/o The Wireless World. [8594]

ALL Recording Discs and Materials in Stock; tracker units, £4/7/6; recording motors, £3/17/6.—Write for further details, Will Day, Ltd., 19, Lisle St., W.C.2. [0595]

FEIGH Recording Sets are Within Reach of All; ball bearing gear box, worm drive traverse; records on any disc, Morse, speech or music; diamond cutter-pickup on tone arm, the set 37/6; 6in. blanks, 3/3 doz.; 10in. discs, 7/- doz.—Electradix, 218, Upper Thames St., London, E.C.4. [0620]

VALVES

ALL Types of American Tubes in Stock of Impex and Arcturus makes at competitive prices.

WE Can Also Supply a Full Range of Guaranteed Replacement Valves for Any British non-ring, American or Continental type at an appreciably lower price.

SEND for Lists of These, and also electrolytic condensers, line cords, resistances, etc.

CHAS. F. WARD, 46, Farringdon St., London, E.C.4. Tel.: Holborn 9703. [0452]

AMERICAN, 2/9; 1,000 non-ring British, from 1/9; bargains galore; lists free.—Shippers, 18, Corporation St., Manchester. [0607]

METROPOLITAN RADIO SERVICE—Special offer. American valves, in makers' cartons, 3/- each; Octals, 3/6 each; American valves, first grade, in all types; trade supplied.—1021, Finchley Rd., N.W.11. Speedwell 3000. [0436]

TEST EQUIPMENT

WEARITE All Wave Battery Oscillator, complete and as new; 90/-—1,350 Stratford Rd., Birmingham, 28. [8606]

COMPONENTS

SECOND-HAND, CLEARANCE, SURPLUS, ETC.

PREMIER SUPPLY STORES.

PLEASE See Our Displayed Advertisement on page 5. [0488]

SOUTHERN RADIO, 46, Lisle St., London, W.C. Ger-rard 6653.—Stocks of receivers and replacement components, as previously advertised. [8548]

COLLARO A.C./D.C. Record-changers, 200-250, plays eight 10in. or 12in. records, mixed, also incorporates repeater and retractor; limited quantity, £5/5, in sealed cartons.

HENRY'S, 72, Wellington Av., Stamford Hill, N.15. Stamford Hill 2907. [8216]

Well-known manufacturers stake their reputations on **SOUND SALES** for **TELEVISION TRANSFORMERS**

We are looking orders from well-known manufacturers for all transformers necessary in the modern Television Chassis, comprising—H.T., Time Base, Line and Frame Transformers. A number of manufacturers have depended exclusively on Sound Sales Mains Transformers for use in their most successful radio productions over the last 10 years. Their experience confirms our claim that Sound Sales Television Transformers are a definite insurance against service troubles. We look forward to receiving YOUR enquiries.

Specified by **SOUND SALES** the Experts
 MARLBOROUGH RD. UPPER HOLLOWAY, LONDON, N.19. (Contractors to the G.P.O., etc.)
 Hours of Business—
 Monday to Friday, 8.30 a.m. to 6 p.m.
SATURDAYS CLOSED

This NEW "R.F. 41" **HARTLEY TURNER** IS A GREAT JOB!



Receiving Unit for use in conjunction with an L.F. Amplifier. 12" x 10" x 8" overall.

Briefly:—4 valve superhet, 5 wavebands: (1) 6 to 10m.; (2) 12.8 to 51m.; (3) 65 to 230m.; (4) 200 to 550m.; (5) 900 to 2,100m. A pentode R.F. operates on all bands except No. 1. Triode-hexode frequency changer. Single pentode I.F. amplifier, two variable band-width transformers giving three degrees of selectivity. Variable IF gain. Linear diode signal and A.V.C. rectification. Proportionate application of A.V.C. bias to R.F. and I.F. stages provides good signal-to-noise ratio and signal-handling capacity. One triode stage of L.F. amplification. Volume and tone controls. Provision for pick-up. Walnut control panel. Flood-lit glass dial, calibrated in metres and station names. Reverse vernier slow motion tuning control. Calibrated magic eye tuning indicator. 18 SWG cadmium plated steel chassis, robust construction. Price including valves and coupling leads, £11.5.0.

Full specification on request. Write now.



THE HARTLEY TURNER RADIO COMPANY
 62 Queensway, London, W.2. Tel.: Bayswater 1102

COMPONENTS—SECOND-HAND CLEARANCE, SURPLUS, ETC.

RYALLS RADIO, 280, High Holborn, London, W.C.1, offer new goods, post free.
ELLIPTICAL Speakers, Celestion, suitable Ekco replacements, 750 and 1,250 ohms, less transformers, speech 25 ohms, new, handle 8 watts, carry up to 120 m.a.; 5/6 each.
AMPLIFIERS, A.C. 200-250v. output 18 watts A.C. from pair 6L6 in push-pull, 3 stage, ample volume for driving extra speakers available. Complete with valves, and pair of elliptical speakers, wired up ready for use; 2/6, carriage paid.
GARRARD AC Induction Type AC7a Gramophone Motors, with pick-ups complete, 200-250v., 12in. turntable and unit plate, auto. stop, speed regulator, new; 32/6 each.
SPEAKERS, pairs, brand new, elliptical cone speakers, made by first class firm, quality of reproduction outstanding, push-pull pentode transformer, fields 325 ohm for smoothing; choke, 3,600 as bleeder, circuit available, handle 10-15w.; 14/- pair.—Ryalls Radio, see above. [8374]
VAUXHALL—Hivac valves, all types, screened iron-cored coils, switch, circuit, 2-gang 11/3; 3-gang 17/-
VAUXHALL—T.C.C. dry, 8 mfd., 2/6; 600v. aluminium containers; T.C.C. 600v. dry, cardboard containers, 8 mfd., 1/9.
VAUXHALL UTILITIES, 163a, Strand, W.C.2.—Ask for free list; metal rectifiers, HT10, 10/-; HT9, 9/-; [8610]
GRUB Screws, assorted B.A. sizes and lengths; 1/6 per gross assorted; postage 1/4d.—Andrews, 30, Everton Rd., Croydon. [8613]
3 WAVE-BAND Tuning Packs for British Valves, aligned and tested; 3-gang H.F., F.C., battery or mains, 32/6 only; 465 K/C 1F's, for above, 2/6 each.—S.A. Radio, 295, Norwood Rd., S.E.24. [8605]
MAINS RADIO DEVELOPMENT Co. Offer Immediate Delivery, carriage paid, call mornings; telephone Tudor 4046; stamp for list 227A; Transatlantic all-wave tuning packs now available from stock; stamp for details.
DUBILIER Mica Tag Condensers, 0.00005, 0.0001, 0.0002, 0.0003, 0.0005 mfd.; 3d., 2/6 dozen.
ERIE 1-watt Colour Coded Unused Resistors, any size, 50 ohms to 5 megohms, your selection; 3d., 2/6 dozen; 2-watt, 6d.
CENTRALAB Latest Potentiometers, long standard spindle, unused, all sizes, 5,000 ohms-2 megohms; 2/-, with mains switch 2/3.
TUBULAR Condensers, 400-volt working, wire ends. Best make, 0.0001-0.05 mfd., 4d.; 0.1 mfd., 4d.; 0.25, 0.5 mfd., 6d.
CLIX Unused Chassis Valveholders, 5-pin, 7-pin, 3d. each; all American sizes, 6d. each; best sleeving, 1 1/2d. yard.
FIFTY Unused N.S.F. 1/4, 1, 2-watt Resistors, wire ends, marked, colour coded, 26 different useful sizes in each parcel; 50 for 2/6 only.
MAINS RADIO DEVELOPMENT Co., 4-6, Muswell Hill Rd., London, N.6. Tudor 4046. [8569]

REPAIRS AND SERVICE

"SERVICE with a Smile."
AMERICAN Valves, spares, linecords, rewinds; repairers of all types of American and British receivers.—F.R.I., Ltd., 22, Howland St., W.1. Museum 5675. [0434]
ANGLO-AMERICAN RADIO, 59, New Oxford St., offer Specialised Repair Service, British and American receivers, all types.—Temple Bar 3231. [8607]
LOUD-SPEAKER Repairs, British, American, any make, 24-hours service; moderate prices.—Sinclair Speakers, Alma Grove, Copenhagen St., N.1. [0590]
GUARANTEED Repairs Any Transformers, choke, motor armature, converter, dynamo, etc.; keenest prices, immediate quotation, prompt, dependable service.—See below.
L.T.P. (LONDON TRANSFORMER PRODUCTS, Ltd.), Willesden, N.W.10. Willesden 6486 (3 lines). [6892]
MAINS Transformer Service, Repairs, rewinds or construction to specification of any type, competitive prices and prompt service.—Sturdy Electric Co., Dip-ton, Newcastle-on-Tyne. [0516]
METROPOLITAN RADIO SERVICE—Guaranteed repairs to American and British receivers; American valves, service parts and rewinds; trade supplied.—1021, Finchley Rd., N.W.1. Speedwell 3000. [0435]
DEGALLIER'S "Reliable Service With a Written Guarantee." First class workmanship, lowest prices; all British and American receivers; let American specialists do the job. 48-hour service.—Degallier's Ltd., 31, Craven Terrace, London, W.2. Pad. 6492. [8552]
REPAIRS to Moving Coil Speakers a Speciality; cones and coils fitted, fields altered, prices, including eliminators, quoted; loud speakers, 4/-; L.F. and output transformers, 4/-, post free; guaranteed satisfaction; trade invited, estimates free; prompt service.—Loud-Speaker Repair Works, 5, Balham Grove, London, Battersea 1321. [0394]

SITUATIONS VACANT

IMPERIAL AIRWAYS Require Radio Officers of British Nationality, aged 23-30, for 'universal service'.
QUALIFICATIONS Include Possession of P.M.G. Air Operator's W.T. Licence. Two years' previous marine or air operating experience desirable. Preference given to holders of 1st Class Marine Certificate. Basic Salary £4 10s. to £6 5s. per week, according to seniority, plus service pay and allowances according to base. Accident Insurance £1,000 provided. Contributory Pension Scheme. Applicants subject to examination by Company's Medical Officer.
WRITTEN Application, giving full details of age, experience and qualifications, should be made to the Flying Establishment Officer, Imperial Airways, Airways House, London, S.W.1. Please mark envelope SEO/L. [8571]

The **LITTLE METER** that does the **BIG JOBS**

THE UNIVERSAL **AVOMINOR**
 Reqd. Trade Mark BRITISH MADE
ELECTRICAL MEASURING INSTRUMENT

D.C. VOLTAGE	
0-75 mv.	0-100 v.
0-5 v.	0-250 v.
0-25 v.	0-500 v.
A.C. VOLTAGE	
0-5 v.	0-100 v.
0-25 v.	0-250 v.
	0-500 v.
D.C. CURRENT	
0-2.5 ma.	0-25 ma.
0-5 "	0-100 "
	0-500 "
RESISTANCE	
0-20,000 ohms	
0-100,000 "	
0-500,000 "	
0-2 megohms	
0-5 "	
0-10 "	

Weighing only 18oz. and measuring but 4 1/2" x 3 1/2" x 1 1/2", this is a really portable meter of high accuracy for measuring A.C. & D.C. volts, D.C. milliamperes and ohms. An accurate moving-coil movement gives a 3" full scale deflection. Total resistance is 200,000 ohms. Complete with instruction booklet, leads, interchangeable testing prods and crocodile clips.

£5.10. (leather case 10/-)
 DEFERRED TERMS IF DESIRED
 Write for descriptive pamphlet
 Sole Proprietors & Manufacturers:—
The Automatic Coil Winder & Electrical Equipment Co., Ltd., Winder House, Douglas Street, London, S.W.1. Phone: Victoria 3404/7

TO SERVICE MEN
 Bargain Offer!!!
 A SERVICE KIT FOR **17/6**

This Service Kit comprises:
4 VOLUME CONTROLS. 20,000, 50,000, 1 meg., 1 meg.
72 RESISTORS. Assorted, colour coded resistors, 1/2 to 3 watts.
2 DOZ. CONDENSERS. Assorted tubular, electrolytic and mica condensers.
1 STEEL CABINET. A very useful steel cabinet with partitions for above, screws, etc.

VALUE £4 for **17/6**
KIT No. 2 comprising resistors and condensers only, as above 12/6
KIT No. 3 comprising volume controls and cabinet only 6/6
SPECIAL OFFER!!!
 Fully shrouded Transformers by America's largest manufacturer. While they last.
 All 230 v. primary and fully impregnated.
 T28708—375/375 v. 150 m/A, 6.3V5A, 2.5V5A, 5V3A 15/-
 T19610—350/350 v. 150 m/A, 2.5V6A, 2.5V2A, 5V3A 12/6
 T7236—375/375 v. 120 m/A, 6.3VCT. 4A, 5V3A 10/6
 T7326—350/350 v. 100 m/A, 6.3VCT. 3A, 5V3A 8/6
 T7307—350/350 v. 80 m/A, 6.3VCT. 3A, 5V3A 7/6
 T7000—320/320 v. 80 m/A, 6.3V4A, 5V3A 7/6
 T6025—320/320 v. 80 m/A, 2.5V6A, 5V3A 7/6
 T464915—110/4A Primary Tapped 110-250 v. 5/6
 T1119AB—110/250 v. 500 watt Auto Transformer 29/6
 The following chokes are interwired and impregnated.
 T7007—250 m/A, 135 ohms, 20-8 Hy., cadmium shrouded 12/6
 T7007A—20 Hy., 250 ohms, 30-12 Hy., cadmium shrouded 12/6
 100 m/A, 20 Hy., 250 ohms, unshrouded, cadmium 4/11
 60 m/A, 15 Hy., 250 ohms 1/11

RADIOMART Telephone: MIDland 3254.
GSNI (Birmingham) Ltd.
44, HOLLOWAY HEAD, BIRMINGHAM

Pamphonic
AMPLIFIERS
 Pamphonic Reproducers Ltd. (Associated with P.Y.E. Ltd.)
 45, St. Pancras Way, London, N.W.1.
 Phone: EUSon 1727.

BARGAINS by ELECTRADIX

THE "LESDEX BIJOU" ELECTRIC WATER PUMP is a centrifugal, all-bronze pump. 2 1/2" lift. 120 gals. per hour. Throws jets 10ft. Runs for 20 hours for a unit. A.C. or D.C., any voltage supplied; or 12 or 30 volts D.C. Costs only 67/6. Supplied in hard-wood case for 5/- extra. High lift Cesspool Pumps. Type "R" with electric motor, 25 10s.

MOTOR BLOWERS. Fume Exhauster and Air Circulators. Strong iron body, 2 1/2" fan, outlet, direct coupled to motor, A.C. 220-v., 65/-; 110-v. D.C., 45/-; D.C. 220-v., 55/-.

BUZZERS. Buzzers for Signals, Wave-meters or Testing. High Note Platinum contacts. List 10/-.

Sale, 6/-. High Note "D.M." Buzzer in case, 3/6. Service Buzzer, No. 2, 12/6. Dill Double Circuit Twin Buzzers, 10/-.

20 volt G.P.O. Buzzers, 3/6. Small Buzzer, 1/6. Large models, 2/6 and 3/6.

BELLS. ALARM BELLS. Mains, battery or magneto waterproof types. 1,000 British House Bells, wall and table. Priority for A.R.P. A.R.P. workers and especially Hains may want portable H.T. for emergency outdoor field transmitters. Portable Hand Generators in teak cases by Eveready, 800 and 1,600 volts D.C.

Portable Emergency Field Cable, unbreakable Army type, 55/- mile. Police and Fire Brigade, day and night Lucas and Aldis Army Signal lamps, telescopic sights, hand or tripod. Crystal sets, 7/6. Battery set kits, oak cabinet panel fitted 2 vari. condensers and range switch, terminal panel, etc., partly wired. Maker's surplus, 15/-.

The West-One MOVING COIL RELAY is a 50 micro-amp. meter fitted with fine platinum contacts for single pole or C.D. up to 150 ma. Flush vertical panel type 2" overall. Resistance of coil 800 ohms approx. Can be used as a master Relay to control a power relay, is so sensitive that it will operate on the reception of a crystal set. Usual price 65/-.

Reduced to 45/-.

RELAYS. Selector 25 way, 8 gang, Auto, 10/-.

Single-blade No. 1 Relays, 1,000 ohms, 6/6. No. 2, 2,000 ohms, 8/-.

C.O. Relays, No. 5, polarised 8 6 and so on. 16 distinct types in stock. Transmitters Relays, Scander Type, 5 amps., 15/-.

Yankee Ham Relays, 7/6. Ship Magnetic, 15/-.

Credal Polarised, 2-way, 25/-.

Ask for Relay brochure "W.W."

TAPE MORSE RECORDERS. For radio to 30 w.p.m. or land line. New portable walnut case, very complete model with key and meter indicator. Standard G.P.O. type with tape reel on base. For experimenters we have a few incomplete with perfect spring drive. Paper tape reels, 6d.

TRANSMITTERS SHIP KEYS with massive contacts, 21/6.

First-class Keys, balanced movement and heavy contacts of gold-silver, tungsten, etc. Panel Keys to fold up flat, 6/6.

Fullerphone double acting Keys, 6/6.

51KBSL R.A.F. Morse Key, solid lacquered brass on mahog. base, 7/6.

Three-colour-light Switch Box with Morse key for code signals, 4/6.

Walter's enclosed Key, all bakelite, 10/6.

Super Transmitting Radio Key, 51KE, 21/-.

TELESCOPES. Navy Telescopes, hand spotters, 25/-.

Gun type, 17/6.

MAGNETIC 1 1/2" COMPASS with Plain Scale. Bevel glass, brass body. A British Bargain for 9d. only.

MERCURY "LESDEX" MERCURY SWITCHES will operate with the same characteristics almost indefinitely, because they are hermetically sealed and absolutely gas tight.

S.P. MERCURY CONTACT TUBES, 5 amps., 4/-; 10 amps., 5/-.

THERMOMETERS. Panel 2 1/2" dial, 5ft. ether tube for distant indicating, reading 0 to 100 deg. Cent., 7/6.

Cambridge ditto, 10/6.

FOURNIER THERMOMETER by Cambridge Instrument Co., 4in. dial, 10-110 deg. Cent. Fitted adjustable electric contacts, 45/-.

2 1/2in. right angle Immersion Thermom., to 150 Cent., 3/6.

15-DAY TIME SWITCHES. Verner 1 amp., 5 amps., 50 amps., 100 amps., 200 amps., cheap.

EMERGENCY ENGINE SETS. Stuart petrol-electric sets, water-cooled, coupled to 30 volts 5 amp. dynamo, £12.

30 volts 10 amps., £17.

Portable air-cooled engine sets, 2 1/2 kw. for field charging.

EDISON Steel Storage Cells. DYNAMOS and Switchboards from 50 watts to 50 kw. Morse chains and wheels, 5-set. Shewgear boxes, 1/2 h.p., 10/-.

Gear boxes, 2-1 for 1/2 h.p., 4/8.

Electric Governors, 7/6.

Bowden R.A.F. Remote Controls, 18 points, 7/6.

PARCELS of experimental coils, magnets, wire, chokes, mikes, condensers, switches, terminals, etc., post free, 10 lbs., 5/-.

1,000 other Bargains in New Sale List "W."

ELECTRADIX RADIOS
218, UPPER THAMES STREET, LONDON, E.C.4
Phone: Central 4611.

Partridge

SPEECH TRANSFORMERS

Partridge Intervalve and Output Transformers have built up and maintained a reputation that is second to none. If you are interested in true high-fidelity reproduction send your enquiries to:—

N. PARTRIDGE
B.Sc., A.M.I.E.E.
KING'S BUILDINGS
DEAN STANLEY STREET
LONDON - - S.W.1
Phone: VIctoria 5035

"Wireless Direction Finding," Third Edition. Price 25s. net. Post free 25s. 9d.

SITUATIONS VACANT

AIR MINISTRY.

DIRECTORATE of Signals.

APPLICATIONS are invited for Appointment as an Assistant Signals Officer in the Civil Aviation Signals Service.

THE commencing salary will be determined according to qualifications and experience, within the scale £350 rising by annual increments of £18 to £500 per annum.

THE Qualifications Required are:—

E **DU**CATION to Degree Standard in Light Electrical Engineering.

E **X**PERIENCE in the Design of Modern Radio Transmitters and Receivers.

P **R**EFERENCE will be given to candidates who have not reached their 45th birthday, and who have the following additional qualifications:—

E **X**PERIENCE in the design, testing and installation of aircraft radio equipment.

A **G**ENERAL Knowledge of the Application of Radio Aids in Aviation.

A **D**MINISTRATIVE Experience.

THE Officer will be largely concerned with approval of new types of aircraft radio apparatus, and his duties will be mainly administrative, but may involve occasional flying as an observer.

S **U**BJECT to a period of satisfactory probation, the selected candidate will be eligible for consideration for a post on the permanent establishment when vacancies arise.

R **E**QUESTS by postcard for forms of application should reach the Under-Secretary of State, Air Ministry (S.I.e.), Adastral House, Kingsway, not later than July 10th, 1939, and the completed forms must be returned by July 14th, 1939. [8602

AIR MINISTRY.

A **N**UMBER of Vacancies Exist for Technical Officers and Assistants II and III at Various Royal Air Force Stations for Work in Connection with the Development, installation and maintenance of wireless equipment.

THE Qualifications Required Are:—

(A) Education to degree standard or equivalent in Physics or electrical engineering, or a sound technical training.

(B) Workshop or laboratory experience in the development of radio communication equipment.

A **K**NOWLEDGE of the Operation and maintenance of Royal Air Force wireless equipment would be an advantage.

S **A**LARY Scales Are:—

B210—Technical Officers: £275 by £18-£455 by £25-£580 (men); £275 by £12-£347 by £18-£464 (by £25-£580 in exceptional cases) (women).

B211—Assistants II.—£315 by £12-£385 (men); £265 by £12-£315 (women).

B212—Assistants III.—£130 by £12-£214 (efficiency bar) by £12-£310 (men); £130 by £12-£214 (efficiency bar) by £12-£260 (women).

THE Appointments Will be Non-pensionable in the first instance.

R **E**QUESTS for the Necessary Form of Application should be Addressed to the Under-Secretary of State, Air Ministry (S.2A/B.8019), Berkeley Square House, Berkeley Square, W.1, quoting the appropriate reference number and enclosing a stamped addressed envelope. [8597

N **O**RTHERN POLYTECHNIC, Holloway, London, N.7.

THE Governors of the Northern Polytechnic Invite Applications for the Post of Laboratory Steward in the Department of Musical Instrument and Radio Technology.

C **A**NDIDATES Should Have a Thorough Knowledge of Scientific Instrument Making, radio servicing and maintenance of laboratory apparatus, and be able to take sole charge of the radio and physical apparatus of the department.

THE Successful Candidate Will be Required to Take up His Duties on the 4th September, 1939.

THE Commencing Wage Will be £3 per Week, rising by annual increments of 4/- to £4 per week. The person appointed must pass a medical examination and contribute 5% of his salary to the Superannuation Fund.

O **N** Receipt of Stamped, addressed foolscap envelope, full particulars and form of application will be forwarded. Forms must be returned not later than the 10th July, 1939.—R. H. Currell, Secretary. [8612

R **A**DIO Component Tester to Take Charge and Maintain test gear.—Bulgin, Barking. [8597

V **A**CANCIES for Technically Trained Men in Radio Valve Factory in London, applicants with production experience preferred; age 21-30.—Write, stating experience, etc., to Box 203, c/o *The Wireless World*. [8603

Y **O**UTHS Required, 15-18, as assemblers for amplifiers, etc., by London firm, must have had radio experience.—Write, giving details of previous employment and age, A., Box 164, c/o *The Wireless World*. [8595

S **E**RVICE Engineers Required by Television Manufacturers, highly skilled men only, car essential; state age, experience, salary required and when available; the present staff are aware of this advertisement.—Reply Box 190, c/o *The Wireless World*. [8599

A **S**SISTANT Test Engineer Required for Audio-frequency Work by London Firm, must have experience of modern testing and measurement equipment.—Write, giving full details, age, previous experience and salary required, T. E., Box 163, c/o *The Wireless World*. [8596

PREMIER
★ **RADIO** ★
STOCKTAKING SALE
SPECIAL CLEARANCE OFFERS!

TWEETERS. Half Price Offer.

ROTHERMEL-BRUSH de Luxe Piezo Electric Power Tweeters, 6 1/2" diam. Freq. response up to 10,000 c.p.s. Handling capacity 6 watts. List Price, 30/-.

Special Half Price Offer, 15/- each.

ROTHERMEL NOISE MASTER, "Anti-Static" Aerial Kit for 12-2,100 metres. Designed to match input impedance of all standard Receivers. Complete Kit with 2-30ft. coils wire, Insulators, Lead-ins, 50ft. special lead-in cable and 2 special matching Transformers. List price, 35/-.

Special Half-Price Offer, 17/6 each.

POTENTIOMETERS WITH SWITCH, 1/2 meg., 1 meg., 20,000 ohms and 10,000 ohms, 1/3 each.

POTENTIOMETERS WITHOUT SWITCH, 2 meg., 1 meg., 1/2 meg., 400,000 ohms, 25,000 ohms, 20,000 ohms, 10,000 ohms, 1/- each.

SPECIAL OFFER—CONTINENTAL MAINS VALVES, 4v. AC Types, 5-pin only, AC/HL, AC/L, AC/P, AC/SG, AC/VMS, AC/HP, AC/VHP, 2/6 each.

20v. 18a AC/DC Types, SG. Var. Mu. SG. Power, HF Pen., 2/- each.

U.S.A. Types, 24, 30, 41, 39/44, 35/51, 55, 56, 57, 58, 71, 77, 78, 85, 89, 2A5, 2A6, 2A7, 2B7, 6A7, 12Z3, 210, 250, all 2 for 3/-.

TUBULAR CONDENSERS, .002, .0001, .0003 and .0005 mfd., 1/- doz. Your choice.

ELECTROLYTIC CONDENSERS. Metal Can. 8 mfd. 320 volts, 2 for 1/6. 8 + 8 mf. 475v. + 10 mf. 50v., 2 for 2/6. 8 + 8 mf. 450v. + 8 mf. 250v., 2 for 2/6.

T.C.C. DRY ELECTROLYTICS. 8 + 8 + 4 mf. 500v., 2/- each.

LISSEN Power Packs in aluminium cases, 150 v., 25 m.a., with 6.3 v. L.T., 100-250 v. mains, 10/8, with Rectifier.

MORSE KEYS. Excellent brass movement on bakelite base, 2/9 each.

BENJAMIN "CLASS B" Output Chokes, 1/6 each.

PREMIER Heavy Duty Class B Driver Transformers, 5/- each.

PREMIER SHORT-WAVE KITS.

Complete to the last detail including all Valves and coils, as well as theoretical and wiring diagrams and lucid instructions for building and working. Each kit is supplied with a steel chassis and Panel and uses plug-in coils to tune from 13 to 170 metres.

1 Valve Short-Wave Receiver or Adapter Kit ... 17/6

1 Valve Short-Wave Superhet Converter Kit ... 20/-

1 Valve Short-Wave A.C. Superhet Converter Kit 22/0

2 Valve Short-Wave Receiver Kit ... 25/-

3 Valve Short-Wave Screen Grid and Pentode Kit. 58/6

PREMIER U.S.A. QUARTZ TRANSMITTING CRYSTALS 7 mc Band, 10/- each, with Calibration Certificate. Enclosed holder and Base, 3/-.

PREMIER SHORT-WAVE COILS, 4- and 6-pin types, 13-26, 22-47, 41-94, 78-170 metres, 1/9 each, with circuit. Special set of S.W. Coils, 14-150 metres, 4/- set, with circuit. Premier 3-band S.W. coil, 11-25, 10-43, 38-86 metres. Suitable any type circuit, 2/6.

ULTRA S.W. COILS, 4-10 metres Wound silver plated Wire. Mounted on Trolitul base. Inside diam. coils 1/2", 3/4, 5/8, 6/8 or 7 turns, complete with base, 1/- each.

UTILITY Micro Cursor Dials, Direct and 100:1 Ratios, 3/9.

PREMIER Short-Wave Condensers, all-brass construction, with Trolitul insulation. 15 mmf., 1/6; 25 mmf., 1/7; 40 mmf., 1/9; 100 mmf., 2/-; 160 mmf., 2/3; 250 mmf., 2/6.

TROLITUL DOUBLE SPACED TRANSMITTING CONDENSERS. 15 mmf., 2/9; 40 mmf., 3/6; 100 mmf., 4/-; 160 mmf., 4/6.

NEW TROLITUL SPLIT STATOR CONDENSERS, 50 x 50 mmf., 10/6.

COIL FORMERS, 4- or 6-pin low-loss, 1/- each. Orders 5/- and over sent Post Free. Under 5/- please add 6d. Postage.

Have you had our 1939 Catalogue, Handbook and Valve Manual? 90 pages of Radio Bargains and Interesting Data. Price 6d.

ALL POST ORDERS TO: Jubilee Works, 167, Lower Clapton Road, London, E.5. Amherst 4723.

CALLERS TO: Jubilee Works, or our NEW PREMISES, 169, FLEET STREET, E.C.4. Central 2833.

or 50, High Street, Clapham, S.W.4. Macaulay 2381.

THE INSTITUTE OF WIRELESS TECHNOLOGY
(Founded in 1925. Incorporated.)

PROFESSIONAL MEMBERSHIP
The advantages of professional membership are open to all qualified wireless engineers.

Full information, with syllabus, may be obtained from the Secretary, Institute of Wireless Technology, 4, Vernon Place, Southampton Row, London, W.C.1. Phone: Holborn 4879.

MOTORCYCLE
Every Thursday 3d. W.W.16

KINGSTON SURREY

UNIQUE OPPORTUNITY FOR A
WIRELESS TRADER
IN THE HEART OF THE TOWN

NEW BUILDING. PROMINENT POSITION
REASONABLE RENTAL

SOLE AGENTS
HEALEY & BAKER
SHOP SPECIALISTS

29, ST. GEORGE STREET, HANOVER
SQUARE, LONDON, W.1

TELEPHONE: MAYFAIR 2965 (14 LINES)

ENGINEERS!
ARE YOU EARNING
LESS THAN £10 PER WEEK?

If so, you cannot afford to carry on without reading our 208-page Handbook. The book explains clearly and definitely many ways of carving out a successful career. Among other things it explains the Services of our unique Appointments Department; outlines Home-Study Courses in all branches of Civil, Mechanical, Electrical, Motor, Aero, Wireless, "Talkie" Engineering, Building, Govt. Employment, etc., and gives details of B.Sc., A.M.I.C.E., A.M.I.E.E., A.M.I.Mech.E., A.M.I.A.E., A.M.I.W.T., A.M.I.R.E., G.P.O., MATRIC., and all Exams. We Guarantee — "NO PASS—NO FEE." Whether you are an old hand or a budding apprentice get this book to-day. FREE and POST FREE.

BRITISH INSTITUTE OF ENGINEERING TECHNOLOGY.
387 Shakespeare House, 17/19, Stratford Place, London, W.1.

THE BEST WAY TO LEARN MORSE
"MASTERS" INSTRUCTIONAL RECORDS

Prepared by an ex-R.A.F. Signal Instructor, these records contain messages at a speed of from 2 to 20 words a minute.

Details on request.
Price 2/6 each or Complete Set of Three 7/-
C. E. MASTERS
Orchard House, Finchampstead Road, Wokingham, Berks.

We don't claim to make the cheapest transformers but we do claim to make good ones. Most of the professional P.A. men seem to think so, too.

W. BRYAN SAVAGE LTD.
Westmoreland Rd., London, N.W.9. Phone: Colindale 7131

INDEX TO ADVERTISEMENTS

Armstrong Manufacturing Co.	2
Automatic Coil Winder Co., Ltd.	4
Birmingham Radiomart G5N1	4
British Institute of Engineering Technology	6
British Rola, Ltd.	2
British Thomson-Houston Co., Ltd., The	1
Electradix Radios	5
Erie Resistor, Ltd.	3
Goodmans Industries, Ltd.	1
Hartley Turner Radio	4
Healey & Baker	6
Institute of Wireless Technology	5
Masters, C. E.	6
Pamphonic Reproducers, Ltd.	4
Partridge, N.	5
Premier Supply Stores	5
Salford Electrical Instruments, Ltd. Inside Front Cover	6
Savage, W. Bryan, Ltd.	6
Sound Sales, Ltd.	4

Printed in England for the Publishers, **LILFFE AND SONS LTD.**, Dorset House, Stamford Street, London, S.E.1, by The Cornwall Press Ltd., Paris Garden, Stamford Street, London, S.E.1. "The Wireless World" can be obtained abroad from the following: FRANCE: W. H. Smith & Son, 248, Rue Rivoli, Paris; Hachette et Cie, Réaumur, Paris; and branches; Messageries Dawson, 4, Rue de Faubourg, Poissoniere, Paris. BELGIUM: W. H. Smith & Son, 74-75, Boulevard Adolphe Max Brussels. AUSTRALIA: Gordon & Gotch, Ltd., Melbourne (Victoria), Sydney (N.S.W.), Brisbane (Queensland), Adelaide (S.A.), Perth (W.A.), and Launceston (Tasmania). NEW ZEALAND: Gordon & Gotch, Ltd., Wellington, Auckland; Christchurch and Dunedin. INDIA: A. H. Wheeler & Co., Bombay, Allahabad and Calcutta. CANADA: Imperial News Co., Toronto, Winnipeg and Vancouver; Benjamin News Co., Montreal; Gordon & Gotch, Ltd., Toronto. SOUTH AFRICA: Central News Agency, Ltd.; Wm. Dawson & Sons (S.A.), Ltd., Cape Town. UNITED STATES: The International News Co., New York.

SITUATIONS VACANT

RADIO Test Operators, male, with experience in routine alignment or fault diagnosis of broadcast receivers, required immediately.—Apply by letter only, stating age, previous experience and remuneration expected, to Employment Dept., E. K. Cole, Ltd., Southend-on-Sea. [8551]

RADIO Valve Applications Engineer Required for Technical Department of Well-known Valve Manufacturer, should have extensive up-to-date experience and intimate knowledge of valves.—Write, stating age, experience and salary required to The British Tungram Radio Works, Ltd., West Rd., Tottenham, N.17. [8614]

SITUATIONS WANTED

SENIOR Radio Development Engineer Seeks Post; specialist in ultra-high frequency and television technique.—Box 65, c/o The Wireless World. [8562]

RADIO Engineer, aged 26, requires situation, experienced service and repair man, 5 years' factory practice with first Austrian radio factories. Austrian subject, English, French, German, commercial knowledge; first class references and certificates.—Box 7392, Samson Clark's, 61, Mortimer St., London, W.1. [8601]

ELECTRIC DRY SHAVERS

REMINGTON, Rand, Shavenmaster, Packard, Casco and Rabaldo.—Trade enquiries to Leonard Heys, 36, Henry St., Blackpool. [0633]

MISCELLANEOUS

CHEAP Printing.—1,000 billheads, 3/6; sample free.—Cretway Press, 18, Buxted, Sussex. [8180]

CP.O. Engineering Dept. (No experience required.) Commencing £3/13 per week. Age 18-23. Excellent prospects.—Free details of entrance examination from B.I.E.T. (Dept. 574), 17-19, Stratford Place, London, W.1. [8522]

EVERY Radio Dealer Who is Not a Regular Reader of "The Wireless and Electrical Trader" should send his trade card at once for a specimen copy and full details of the "Trader" Services. "The Wireless and Electrical Trader" has the widest influence, the largest weekly circulation, and is read by all the leading manufacturers and traders. Trade only, 15/- per annum, post free.—Published at Dorset House, Stamford St., London, S.E.1. [0615]

ENGINEER'S Guide to Success Shows How to Secure Quality in Television, Radio, Engineering and Servicing, sound, recording, wireless communication, etc., by studying at home with the T.I.G.B. Write to-day for this Great Guide—free—which gives full particulars, contains the world's widest choice of engineering courses—over 200—and alone gives the regulations for qualifications such as A.M.I.E.E., A.M.I.R.E., A.M.I.T.E., A.M.I.W.T., C. and G., etc. Training until successful guaranteed.—The Technological Institute of Great Britain, 82, Temple Bar House, London, E.C.4. (Founded 1917. 20,000 successes.) [8526]

PATENT AND TRADE MARK AGENTS

GEE and Co. (H. T. P. Gee, Mem. R.S.G.B., etc.), 51-52, Chancery Lane, London, W.C.2. Holborn 4547-8. Handbook free. [0001]

TUITION

RADIO Training.—P.M.G. exams. and I.E.E. Diploma: prospectus free.—Technical College, Hull. [0611]

PRACTICAL Radio and Television Home Study Courses; booklet free.—I.P.E., 3, Shirley Rd., London, W.4. [8506]

WIRELESS.—Complete training, Marine, Broadcast and Television. Posts waiting. Mod. fees. Boarders taken. Approved college, prosp.—Dept. W., London Radio College, Stamford Park Rd., London, W.4. (Chi. 3244.) [0580]

BUSINESSES AND PROPERTY FOR SALE, TO BE LET, OR WANTED

"THE Wireless and Electrical Trader" is an essential part of the equipment of every Wireless Trader; its pages reflect the very latest turn of trade events, and it is read by all the leading dealers and manufacturers, for particulars of businesses offered or wanted. By subscription to the trade only, 15/- per annum, post free.—Send your trade card for specimen copy to Dorset House, Stamford St., London, S.E.1. [0614]

BOOKS, INSTRUCTION, ETC.

ALL Wireless and Radio Engineering Books Available on New Financial Terms, as low as 2/6 monthly.—Write a card for details from Phoenix, Chandos Place, W.C.2. [8484]

AMERICAN Valve Data.—The new 200-page Raytheon Valve Data Book gives full characteristics and applications of all types of American valves; invaluable to all servicemen; post free, 2/3; abroad, 3/-.—Leonard Heys, 36, Henry St., Blackpool. [0594]

"FOUNDATIONS of Wireless." By A. L. M. Sowerby, M.Sc. Second edition. An elementary textbook on receivers. Deals fully with the construction of wireless sets, valves, and the process of detection. Price 4/6 net. By post 4/11, from Hiffe and Sons, Ltd., Dorset House, Stamford Street, London, S.E.1.

"RADIO Data Charts." By R. T. Beatty, M.A., B.E., D.Sc. Second edition. A series of Abacs providing most of the essential data required in receiver design and enabling problems to be solved without having recourse to complicated mathematical formulae. Price 4/6 net. By post 4/10, from Hiffe and Sons, Ltd., Dorset House, Stamford St., London, S.E.1.

FOURTH EDITION—
Revised and Enlarged with 50
Additional Pages

WIRELESS SERVICING MANUAL

By **W. T. COCKING**
(of "The Wireless World")

The most complete book of reference of its kind. A reliable practical guide for amateur and professional.

The present Edition of the "Wireless Servicing Manual" brings the material of the book right up to date and includes an additional chapter on television receivers which is practically the only source of servicing information available on this subject.

Testing apparatus is fully dealt with and the methods of locating and curing faults in receiving equipment are explained in detail.

Ganging, Automatic Volume Control, Instability, Distortion, Mains Hum, Whistles, Local Interference and Aerials are all separately treated.

The reference material, including base-connections for British, Continental and American valves and the various colour codes for components, has been extended and revised.

BOUND IN CLOTH BOARDS
SIZE 7½ ins. x 5 ins.
288 Pages

PRICE 5/- net
By post 5/5

Issued in conjunction with
"THE WIRELESS WORLD" and
Published by the Proprietors:—

LILFFE & SONS LTD.,
Dorset House, Stamford Street,
London, S.E.1

THE ELEMENTARY PRINCIPLES OF WIRELESS TELEGRAPHY AND TELEPHONY

By R. D. BANGAY

Third Edition. Revised by O. F. BROWN, B.Sc.

FOR many years this volume has been the standard book of instruction for wireless beginners and students. The progress of wireless during recent years has made necessary the New Edition, which covers the whole subject in a clear and simple style. Attention is given to the theoretical elements of electricity and magnetism, the dynamo and the properties of waves.

Many new chapters have been added and descriptions of circuits have also been included.

A leaflet giving full particulars of the volume and a synopsis of chapters will be sent on request.

PRICE:

7/6 net. By post 8/-

From all leading Booksellers
or direct from the Publishers

ILIFFE & SONS LTD., DORSET HOUSE, STAMFORD STREET, LONDON, S.E.1
w.w.97

The ELECTRICAL REVIEW

The Complete Technical Journal

Practical articles on all aspects of electricity supply and utilisation—Industrial, commercial and domestic. Latest news of the electrical industry and developments. Advertisement pages form a comprehensive buyers' guide.

Contents of June 23rd Issue :—

CABLE RESEARCH AND TESTING

A description of the arrangements at Henley's extended establishment at Gravesend.

ELECTRICITY IN THE RHODESIAS

Recent developments are discussed and some account given of the electrical plant at the gold and copper mines.

BRIGHTON EXTENSIONS

New 37,500-kV. Brush-Ljungstrom set and boiler plant at the Southwick station.

OVERSEAS ELECTRICAL TRADE

Figures of exports and imports during May.

NEWS OF THE WEEK

EVERY FRIDAY 6d.

Subscriptions : United Kingdom £1 14s.
Canada £1 12s. 6d. Other Countries
£2 1s. 6d. per annum. post free.

ELECTRICAL REVIEW LTD.

Dorset House, Stamford Street, London, S.E.1

Third Edition of

WIRELESS DIRECTION FINDING

By R. KEEN, B. Eng.

A BOOK OF INSTRUCTION AND REFERENCE FOR ENGINEERS, TECHNICIANS, TELEGRAPHISTS AND OTHERS ENGAGED OR INTERESTED IN THE USE OF DIRECTIVE WIRELESS TELEGRAPHY FOR THE NAVIGATION OF SHIPS AND AIRCRAFT.

Deals with the principles of Wireless Direction Finding and gives an account of the circuits and apparatus used in its application to navigation. The Adcock Aerial has a separate chapter covering its principles, installation and performance. Shore, Ship and Aircraft installations, as well as a special section on the choice of a suitable site for the Aircraft Ground D.F. with Adcock Aerials are included.

Also useful references to a selected list of some 600 of the more important contributions to the literature of D.F.

800 pages
550 illustrations

25/- net

By post 25/9

From leading Booksellers or direct from the Publishers:

ILIFFE & SONS LTD., DORSET HOUSE, STAMFORD STREET, LONDON, S.E.1

DAILY SKETCH

FOR INSIDE INFORMATION

- Explains the News
- Anticipates the News
- Makes Clear the Tangled Web of the News

Every Day more People buy the
Daily Sketch to

BE "IN THE KNOW"

The

Wireless World

6^D

*THE
PRACTICAL
RADIO & TELEVISION JOURNAL*

Thursday, June 29th, 1939



**VIBRATORS
HOW THEY WORK**

BELLING-LEE

PARTS specified
for 'WIRELESS WORLD'
MAGNETIC TELEVISION
RECEIVERS

D.I DIODE VALVE HOLDER

Specially made for the Midget Diode Valves now in use. Silver plated contacts with soldering connection. Strongly constructed.

No. 357/H High Voltage type with insulated mounting pillars Price ea. 1/6



HIGH VOLTAGE VALVE HOLDER

(Reg. Design 821026)

Designed for rectifier valve in Television receivers, etc. Extra long creepage distances for high volts working. When tested with D.C. plus A.C. super-imposed, corona becomes visible in dark at 10,750v peak. Voltage consisted of 5,375v. D.C. plus 5,375 v. peak A.C. Tested on 50c/s A.C. without D.C. corona first occurred at 7,300 v.

No. 352 Price ea. 1/-



FUSED MAINS INPUT CONNECTOR

Bakelite moulding, designed for efficiency and safety. On removing cover, fuses are immediately accessible and circuit is dead. Conforms to B.S.S. 5 amp. standard, please state fuse rating required.

No. 1114 Price ea. 4/3

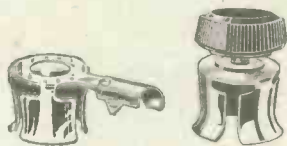

PLUG TOP VALVE CONNECTORS

Essential for use with most modern valves. No other means of connection provided. All metal parts silver plated. Simplest form, spring brass

No. 1175 Price ea. 1d.

With Insulated terminal head No. 1167 Price ea. 3d.

'B' TYPE TERMINAL

(Patent 248921)

Non-rotating name, bakelite insulated, anti-twist wedge on collar, polished black, white letters. Insulation washer. With all Television and standard markings. Each in carton with guarantee.



No. 1001 Price ea. 8d.

BELLING & LEE LTD
CAMBRIDGE ARTERIAL ROAD, ENFIELD, MIDDX

B.I. COPPER EARTHING RODS

for WIRELESS APPARATUS

(U.K. Patent Nos. 238598, 429385, 430040.)

100% MORE SURFACE AREA

Designed to give a low resistance earth contact. Made from solid drawn H.C. copper. The multiple fins ensure larger surface area and better contact with the earth than any driving earth of similar diameter and weight at present on the market; giving nearly 50 per cent. more contact area than a circular rod of equal diameter, or 100 per cent. more than a solid rod of equal weight. About 1 1/2" of the rod is left exposed and the earth lead is simply clamped against the rod by means of the copper clamp ring and screw. No sweating or soldering is required. Supplied in two standard sizes, 18" and 24". Longer rods of similar type can be supplied, if desired, to meet special requirements.

BRITISH INSULATED CABLES LTD.,
CABLE MAKERS AND ELECTRICAL ENGINEERS,
PRESCOT, LANCS. Tel. No. PRESCOT 6571

Memo

Don't forget

Player's

Please

PLAYER'S NAVY CUT CIGARETTES

MEDIUM or MILD
10 for 6½^d 20 for 10½^d

The Wireless World

THE
PRACTICAL RADIO
JOURNAL
29th Year of Publication

No. 1035.

THURSDAY, JUNE 29TH, 1939.

VOL. XLIV. No. 26.

Proprietors : ILIFFE & SONS LTD.

Editor :
HUGH S. POCKOCK.

Editorial,
Advertising and Publishing Offices :
DORSET HOUSE, STAMFORD STREET,
LONDON, S.E.1.

Telephone : Waterloo 3333 (50 lines).
Telegrams : "Ethaworld, Sedist, London."

COVENTRY : 8-10, Corporation Street.
Telegrams : Telephone :
"Autocar, Coventry." 5210 Coventry.

BIRMINGHAM :
Guildhall Buildings, Navigation Street, 2.
Telegrams : Telephone :
"Autopress, Birmingham." 2971 Midland (5 lines).

MANCHESTER : 260, Deansgate, 3.
Telegrams : Telephone :
"Iliffe, Manchester." Blackfriars 4412 (4 lines).

GLASGOW : 26B, Renfield Street, C.2.
Telegrams : "Iliffe, Glasgow." Telephone : Central 4857.

PUBLISHED WEEKLY. ENTERED AS SECOND
CLASS MATTER AT NEW YORK, N.Y.

Subscription Rates :

Home and Canada, £1 10s. 4d. ; other
countries, £1 12s. 6d. per annum.

As many of the circuits and apparatus described in these
pages are covered by patents, readers are advised, before
making use of them, to satisfy themselves that they would
not be infringing patents.

CONTENTS

	Page
Editorial Comment	593
Vibrators : A Simplified Explana- tion of How They Work .. .	594
Distortion in Transformer Cores. Part II—The "Partridge Dis- tortion Index" and Its Calcula- tion	597
Letters to the Editor	600
Television Service Area Map ..	601
Magnetic Television Receiver. Part I—Characteristics of Mod- ern Apparatus	602
News of the Week	605
Wanted—A New Kind of Receiver	607
Unbiased	610
Recording on Steel Tape	611
Microphones at Alexandra Palace	613
Random Radiations	614
Recent Inventions	616

EDITORIAL COMMENT

Television

The Need for Haste

IN the early stages of television the *Wireless World* repeatedly urged the authorities and the manufacturers to develop the new service with caution, and not to rush into an enormous production of sets nor extend television stations to other parts of the country until the foundations of the service had been firmly laid in London, and sufficient evidence collected to provide the assurance that extension to the provinces would be justified by results.

We are fully convinced to-day that that advice was sound at the time and that had any other course been adopted the radio industry would not have been able to adapt itself quickly enough to quantity production, nor would the B.B.C. have been able to cope with more stations without the service suffering in quality and the reliability of receiving sets being found wanting.

No Longer Experimental

To-day the period necessary for consolidation has passed. Manufacturers are in a position to supply sets for a rapidly growing public demand, and the experience they have gained during a period of gradual development has enabled them to face production now in quantity with reliability.

B.B.C. experience has been extensive enough now to make those responsible confident that they can run additional stations. We have also had assurances that the solution of the problem of a link between one station and another has been suitably solved.

If there had been any question of abandoning television the decision to

do so should have been taken long ago. Since television is going on, the delay in extending it is unwarranted.

The radio industry is just in that position where it has sunk a very large amount of capital in television, so far unremuneratively when considered collectively, but could now reap a reward if the market for television sets were extended.

End This Indecision

The success of the B.B.C. transmissions is no longer in question. It is necessary to have owned a set over the period of development to appreciate how great has been the progress made and how excellent a source of interest and entertainment the programmes are to-day. No longer is there any need to hesitate to recommend investment in a television set, even to our closest friends.

What is the reason for the present hesitancy? The Television Advisory Committee showed so much courage and leadership in the early stages that it seems inconceivable that that same committee can have lost its nerve when called upon to face the next step.

Even neglecting the question of national prestige in an enterprise where so far we have held the lead in the world, the other considerations we have mentioned are in themselves enough to make further hesitation unjustifiable.

To turn back now is out of the question. To stand still where we are, leaving the radio industry with the burden of expenditure already met but unable to go on to prosperity, is equally unthinkable. The next step must be taken, and, realising that it will require time before a second station can be in actual operation, the decision should be made at once.

Vibrators

A SIMPLIFIED EXPLANATION OF HOW THEY WORK

FUNDAMENTALLY, vibratory converters act by the periodical interruption (by a buzzer) of the primary circuit of a step-up transformer through which a fairly heavy current is passed from accumulator batteries. As the current in the primary is started and stopped, the field which it produces changes rapidly and induces in the secondary winding an alternating EMF much greater than that of the input accumulator. This can be rectified (either by additional contacts on the buzzer reed or, in the case of very high output voltages, by valve rectifiers) and applied, after smoothing, to circuits normally employing HT batteries or mains supplies, such as receivers and transmitters.

This seems at first sight to be merely an application of the well-known buzzer—or, to the highbrow, "vibrating reed motor," principle; and that is supposed to be very simple to understand. As a matter of fact, large and brain-cracking books have been written on the behaviour of the currents and voltages occurring in the simple buzzer, especially in the case of the induction coil which was much used before the advent of valve oscillators for the study of electrical oscillation, and many of the problems raised by buzzer action have cropped up again in connection with its

By
W. H. CAZALY
Grad. I.W.T.

use in vibrators.

It is easy to make a vibrator that will work after a fashion. Amateur experimenters have done so for many years, using all sorts of gear, such as old spark coils and electric bell mechanisms. Some obvious circuits are given in Fig. 1. But unless these are very carefully designed and constructed, their efficiency is poor. To obtain even 10 mA output at 100 volts (1 watt), at least 2 watts must be put in by the accumulators. Even this 50 per cent efficiency is not easy to secure with low input voltages, and length of life of the contacts less so. However, commercial vibrators are available which not only give their rated outputs with efficiencies of the order of 70 to 80 per cent. (which is seldom attained by rotary converters), but, which is equally important, remain in good working order for thousands of hours' use. These results are obtained not only by the employment of specially suitable materials, but by the application



of principles of which it is proposed to give a brief outline.

The first thing to note is that in even the simplest vibrator circuits (say, Fig. 1 (a)) the action may be divided into at least three components, involving regular and cyclic action. They are (1) the mechanical periodicity of the vibrating reed; (2) the making and breaking of the contacts; (3) the resonant frequency of the transformer and its associated condensers. Keeping these in action requires the expenditure of energy, which is provided by the input accumulators. If they

VIBRATORY converters — "vibrators" for short—are coming more and more into popular use for obtaining high-voltage supplies from low-voltage sources such as accumulators. They are, however, far from being the simple pieces of apparatus that their basic principle of action might at first suggest.

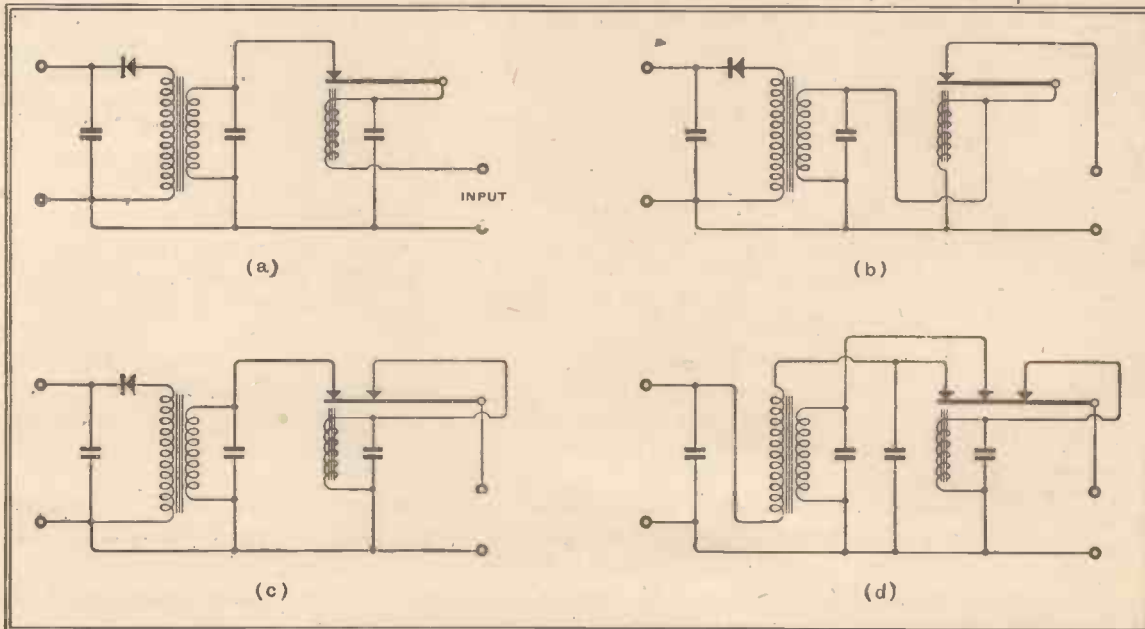

Fig. 1.—Possible vibratory rectifier circuits. (a) Primary in series with buzzer coil: primary current passes through buzzer coil, contacts carry total energising current: efficiency poor. (b) Primary in parallel with buzzer coil, hence primary inductance lowered: contacts carry total current. (c) Primary and buzzer in parallel, but separate contacts. (d) Developed from (c) with self-rectifying contacts, buffer and tank condensers. Basis of practical circuit for "half-wave" rectification—i.e. only one half of reed travel utilised to make and break contacts. Compare with Fig. 2. The rectifier in (a), (b) and (c) must withstand the high reverse voltage.

are all out of tune with each other, this energy requirement rises inordinately and the input accumulators either have to be of comparatively high voltage or must pass very heavy current, which means that they must be bulky and heavy and be frequently recharged.

It is like trying to keep three pendulums swinging by erratic and mis-timed hits with a hammer. If the hits can be delivered at precise and regular times and the periodicities of the pendulums can be made to suit, they can be kept going with very little energy. If they are made

Vibrators—

to do some work while they are swinging—that is, if they are “damped”—then more energy has to be used on them; but it will be doing useful work.

That is the sort of thing aimed at in vibrators. The energy given out by the accumulators just to keep the reed vibrating, the contacts opening and closing, and the currents and voltages occurring in the transformer windings, must be as little as

could be made to act as a single tuned circuit in almost exact resonance with the reed. In practice the load is never reactive, since it consists of an anode or some circuit absorbing power and is therefore equivalent to a resistive load. However, for a given load and reed frequency, the transformer can be designed at least to an approximation to resonance. This disposes of one problem at least partially—though saying this is like a well-known cookery recipe, which begins “Take a hare—.” First, of course, it is necessary to catch the hare.

Before the transformer can be designed and made up, many inter-related factors must be taken into account. Correlating these—the turns ratio to obtain the correct step-up of voltage, the inductance of the secondary, its self-capacity (which partially tunes it), the gauges of wire to carry the expected currents, the DC resistance of the primary, the dimensions and material

coil is not specially tuned to the reed. Even the operation of extra contacts adds little to its requirements of energy from the accumulators. It is essential, however, that it should work very smoothly and constantly and at a frequency rather lower than that normally found with buzzers. Making and breaking the contacts at high frequency renders it difficult to design the transformer so that the primary is satisfactorily energised during the short contact period and also requires more energy to move the reed rapidly. Excessively high transient voltages are also set up, which raise insulation problems. To vibrate for long periods and constantly, special steels are usually employed.

Associated Apparatus

The action of the vibrator and the parts played by the other components of the circuit—the contacts and the buffer condensers—is best understood by following the progress of the curves in Fig. 2, in conjunction with a little imagination applied to Fig. 3, which is a working circuit omitting RF chokes, screening, etc. On closing the main switch, S₁, a current starts to flow through the buzzer energising coil, L₁ and one-half of the primary, L₂. The current in L₁ may be ignored, since its only function is to attract the reed. The current through L₂ will rise rapidly at first and then slow down its rate of change until it tends to reach its maximum of, in this case, 3 amperes, which is determined by the DC resistance of L₂. As it rises the change in its magnetic field induces an EMF in the secondary winding. Now S₆ is still open; hence only L₄ is in circuit in series with the reservoir condenser C₆, which is charged up by the EMF induced in L₄. If the primary current were allowed to reach its DC maximum, at point C in Fig. 2, the induced EMF in L₄ would fall as the rate of change of primary current slowed down,

possible. If the secondary is loaded, i.e., if its output is fed to a circuit doing something requiring power, the load energy must be reflected back into the input in the form of reasonably proportional increase of current in the primary circuit. There are incidental problems, also, due mainly to the fact that when inductive circuits are broken, high back EMF's and brief but heavy currents are set up, which require good insulation, refractory and carefully made contacts, and accessory components to act as buffers to these shock releases of energy. If these incidental problems are not solved the life of the vibrator is short.

The Main Problems

The actions involved are extremely complex, but it is possible to outline some of the main points that have to be considered. The design of the transformer is about the most important problem, and it is vastly complicated by the fact that the currents and voltages that occur in its windings do not vary according to a sine law. Some idea of the complexity of the waveforms involved may be had from a glance at the curves given in Fig. 2.

In general, the design of the transformer must be such that it behaves as a tuned circuit that resonates at the frequency (or double the frequency) of the reed vibrations with a given load across the secondary. Of course, if the load were purely reactive and the input EMF varied according to the sine law, the transformer

of the core to suit the widely varying magnetising currents, to mention a few—is quite enough to create a headache in even a fairly competent mathematician, though the work can be considerably simplified by making use of *The Wireless World* Radio Data Charts. Even then, there is still the problem of selecting the material and the dimensions of the reed, so that it will vibrate naturally to suit the transformer.

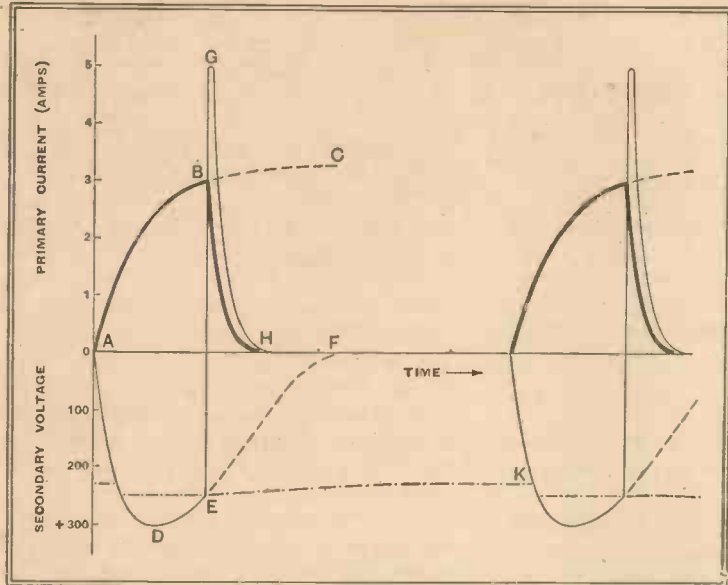

Fig. 2.—Variations of current and voltage during a complete contact period. The primary current is represented by the thick line, the secondary by the thin line and the reservoir condenser charge by the chain dotted line.

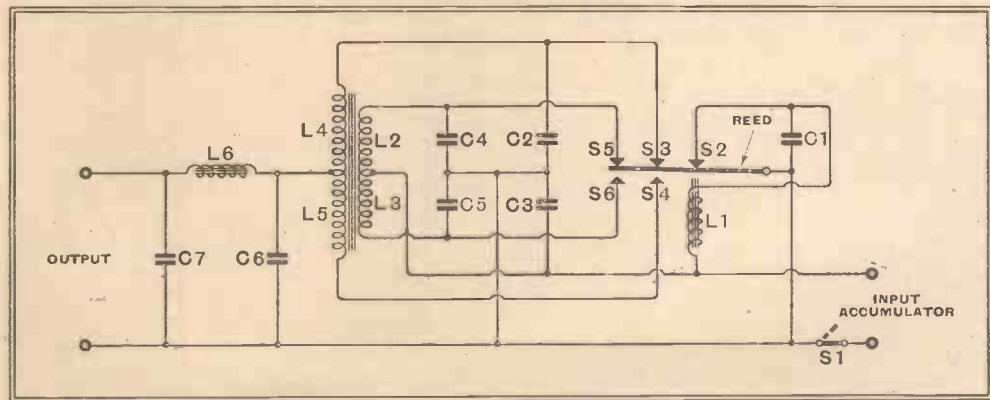

Fig. 3.—Basic circuit of a typical vibratory rectifier. Screening and R.F. chokes have been omitted for simplicity.

The reed motor, or buzzer, itself requires the least effort to design, for unless the buzzer coil is connected in series with the primary circuit inductance, which is not usual, it forms a separate component with little effect on the rest of the circuit. Buzzers can be made to work with very little energy, even if the buzzer energising

and C₆, after being charged up to 300 volts, would discharge again through the part of its curve DEF. Hence, S₅ is arranged to break the circuit of L₂ when the current, still rising rapidly enough to maintain 250 volts of induced EMF across L₄, reaches point B, and S₃ opens simultaneously or a tiny moment before so that

Vibrators—

C6 is left in the charged condition. The opening of S5 allows the primary current to fall, and it does so very rapidly because the secondary is now open-circuited: this rapid collapse of the primary field induces a very high secondary EMF, as is shown occurring in the secondary voltage curve EGH.

The peak voltage at G would cause violent sparking across the gap at S3 were it not for the buffer condenser C2, which comes into circuit as S3 is opened and is charged by this shock EMF until the gap has had time to open far enough for no spark to pass. C4 is performing a similar office for contact S5. The reed, attracted by L1, now passes across to make contacts at S4 and S6, and a cycle exactly similar to the one described takes place, with L3 and L5 now energised. During the time that the reed is passing from one set of contacts to the other and both sets are open, the reservoir condenser C6 discharges partially through L6 and the load circuit, and its voltage falls as shown on the curve from E to K. When S4 and S6 are closed, it is charged up again to 250 volts.

Even this very elementary outline of what happens is sufficient to show the extreme importance of everything happening at exactly the right moment. The distance the reed travels is not great and the time it takes to do so is small. Hence, the slightest maladjustment of the timing of the contacts is seriously detrimental to efficiency. It is impossible, in fact, to adjust the contacts without proper jigs, as are used by the manufacturers, and attempts to do so are likely not only to fail, but irreparably to damage the contacts in a very short period of subsequent use.

Results of Maladjustment

For instance, if the contacts open simultaneously, but too soon, C6 begins to discharge the sooner and so falls at K to a lower than normal voltage. The hum level rises unless the output circuits are very generously smoothed and the DC output voltage falls. If they do not open soon enough, the hum level and regulation are slightly improved, but again the output voltage falls. If the contacts do not open and close simultaneously, either C6 is insufficiently charged or charged to too low a voltage, or, if S5 opens before S3, the high reversed EMF causes an extremely heavy current to pass, discharges C6, and makes so violent a spark at S3 (dependent on the exact moment when it does open) that the contact surfaces are quickly burned and may even fuse together. S5, remaining closed after S3 has opened, means that current is flowing uselessly in the primary without inducing a charging EMF for C6 and represents a loss of efficiency.

The transformer and the buffer condensers together form a tuned circuit. Hence the capacities of the buffer condensers matter considerably. If replaced, they should be of the correct values,

neither more nor less. As they have to deal with very high though momentary voltages, and as they are constantly being charged and discharged, they should be of first class make and adequately rated. Using buffer condensers of too large a capacity will so alter the tuning of the transformer that the primary is insufficiently energised during the brief closing of the contacts and efficiency will fall off. Too small buffer condensers will cause a very heavy current to pass through the primary, and this, when it stops and its field collapses, will result in excessively high reversed EMFs, causing a large spark to occur at the contacts and very much shortening their effective life.

Mechanical Analogy

It should always be borne in mind that a vibrator is analogous to a four-stroke internal-combustion engine rather than to a steam engine. The latter is designed to take great but steady and smooth pressures. The former is designed to handle energy released in a series of violently explosive packets, like repeated blows with a hammer. So the vibrator has to deal with short, intense bursts of energy as the contacts close and open and hand them out at the output terminals as a steady, smooth flow of DC through the external circuits.

The resistive load on the secondary plays an important part in determining the phasing and the currents and voltages. Vibrators are designed for certain outputs at which they are rated, and if they are called on to deliver other outputs, their efficiency falls sharply. This is one of the most serious limitations of the vibratory converter, since it precludes its use to supply amplifiers operating on Class "B" or "C" principles without special precautions which lower efficiency and deprives it of the universality of the HT battery. For instance, a vibrator rated to give 200 volts at 50 mA (10 watts) with an efficiency of 70 per cent. may give 100 volts at 10 mA with efficiency of the order only of 10 to 20 per cent. Nor, at this low output, will its life be lengthened; indeed, owing to the throwing out of phase of the winding resonances, sparking may ensue and the life be actually shortened.

There are, however, so many vibrators on the market rated for outputs from 130 volts 10 mA to 250 volts at 50 mA, that there should be no difficulty in choosing one to suit a particular receiver or transmitter, and as long as it is kept to the one job it will prove satisfactory. If for some reason a large output vibrator is required to provide less than its rated output, it is permissible to reduce its output without much loss of efficiency by lowering the input voltage. This should be done by using lower-voltage input accumulator batteries—say, 4 volts instead of 6 volts. It is not advisable to drop the voltage through a resistance in the primary circuit as this alters the phasing of the transformer circuits.

Interference still remains only a partially solved problem with vibrators. It is diffi-

cult completely to avoid sparking, and even if this is reduced to invisibility, there are still high-frequency oscillations set up in the circuits which radiate directly and are propagated through stray and self-capacities and inductances. The brute force methods involved in very thorough screening and RF choking seem to be most effective, though a great deal can be done by judicious earthing. It must not be forgotten that the leads to the input accumulators carry the RF effects of sparking in the primary, and by "thorough" screening would be meant the screening, not only of the vibrator unit itself, but these leads and the input accumulators themselves, including any leads taken to the main input switch S1, if this is not placed at the vibrator unit. For the same reason the input accumulators must not supply also the filament current of battery valves, though with care they can supply the heaters of indirectly heated valves. RF chokes are necessities in both output leads and must be placed within the screening of the vibrator. The earthing system has considerable effect, too, for if the vibrator and its screening are earthed by a short lead to a really good earth, and the receiver is given a separate earth at a little distance from that of the vibrator, interference should be reduced to inaudibility provided that the receiver RF circuits, including the aerial lead-in, are also screened. To sum up this matter of screening, the vibrator is like any other source of strong local interference and should be dealt with accordingly.

**Morse Operating
INSTRUCTIONAL COURSE**

A COMPREHENSIVE course in morse operating is being prepared by Messrs. L. F. Miller and R. J. Bennett, of 81, Wellesley Road, Chiswick, London, W.4. It covers not only the learning of the code and the acquisition of speed, but also such subjects as correct methods of key manipulation, practice exercises and suggestions as to the style of handwriting most conducive to

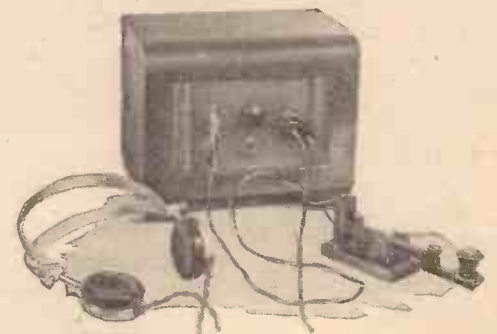

Morse practice set, complete with key and headphones.

speed. A valve oscillator practice set is supplied to students.

Readers of our own recently issued booklet "Learning Morse," and other would-be operators who have already acquired the elements of the subject, will perhaps be interested to learn that, if sufficient response is forthcoming, Messrs. Miller and Bennett propose to arrange practical instructional classes.

Distortion in Transformer Cores

Part II.—THE "PARTRIDGE DISTORTION INDEX" AND ITS CALCULATIONS

Cores

IT can be shown both experimentally and theoretically (see appendix) that the harmonic distortion appearing in the voltage across the secondary terminals of an output transformer, having a closed magnetic circuit not polarised by DC, is:—

$$\text{Distortion (per cent.)} = x \times \frac{R}{Z_F} \dots \dots (3)$$

where x is the percentage distortion taken from the curves of Fig. 5, R is the parallel impedance of the valve and its external

By N. PARTRIDGE, B.Sc. (Eng.),
A.M.I.E.E.

load, as calculated in this manner, should normally be the optimum load for the valve.

Z_F and x are both variable, and are dependent upon the frequency and the flux density (B) in the core of the transformer. The way in which Z_F varies with flux density in the case of Silcor 2 has been illustrated in Fig. 8.

If the iron losses are overlooked, the simplest method of determining Z_F is to measure the inductance of the transformer primary at any known flux density. The value of inductance at any other density can be deduced from the information contained in Fig. 8,

and the impedance, to a sufficiently close approximation for the present purpose, is:—

$$Z_F = 2\pi \times \text{frequency} \times \text{inductance} \dots (4)$$

The values of x can be taken directly from Fig. 5, providing the core material is Silcor 2. It can be the percentage content of any one harmonic at the chosen flux density or, alternatively, it may be the total harmonic distortion. It is, of course, absolutely essential that Z_F and x be evaluated at one and the same flux density.

Practical Examples

To examine the degree of distortion that may be found in practice, three different

IN Part I of this series of articles the author showed that the iron core of any output transformer can give rise to serious harmonic distortion. Part II explains by a number of examples how the magnitude of this distortion may be calculated in practical cases.

transformer designs will be reviewed. The calculations relating to the first example will be given in full so that the reader can see exactly how formula (3) is used in conjunction with Fig 5 and Fig. 8.

Example 1.—Take an output stage consisting of two DO24 valves in Class "A" push-pull, giving a maximum output of 12 watts. The optimum load given by the makers is 5,000 ohms, anode to anode, and the AC resistance per valve is 2,500 ohms.

A transformer having a primary winding of 2,200 turns upon a rin. stack of No. 4 stampings of Silcor 2 will have a measured impedance of approximately 21,800 ohms at 50 c/s when the flux density is 4,000 lines per sq. cm. Given this one value of the impedance at a stated

anode load taken together, and Z_F is the impedance of the transformer primary to the fundamental frequency.

The reader is advised not to worry too much about the origin of this formula. Mathematical reasoning is very fascinating, but must not be allowed to interrupt the major line of thought. Our immediate interest is centred upon the behaviour of output transformers, and formula (3) will yield the desired information providing it is used properly. Let us examine the various terms one at a time.

" R " is the combined impedance of the AC resistance of the valve and its effective anode load when connected in parallel. The former is a reasonably constant figure which can be extracted from the data given by the valve manufacturers. It depends upon the characteristics of the valve and the manner in which the valve is used, but is quite independent of the transformer design. The external anode load will be the true load connected across the secondary of the output transformer multiplied by the square of the transformer ratio. The anode

TABLE 1

B	Z_F	x from Fig. 5			$x \times \frac{R}{Z_F}$ ($R = 2,500$)			
		3rd	5th	7th	3rd	5th	7th	Total
2,000	16,000	11.0	5.3	4.5	1.72	0.83	0.70	3.25
4,000	21,800	17.2	9.5	7.0	1.97	1.08	0.80	3.85
6,000	22,900	22.3	13.1	10.6	2.43	1.43	1.16	5.02
8,000	21,200	27.0	16.0	15.6	3.18	1.88	1.84	6.90
10,000	17,300	31.0	18.7	20.3	4.48	2.71	2.94	10.13

TABLE 2

Frequency c/s	Watts	B	Z_F	x	$x \times \frac{R}{Z_F}$
40	12	12,900	8,180	110.0	33.6
50	12	10,300	16,700	71.0	10.6
70	12	7,350	30,900	54.5	4.4
90	12	5,720	41,300	44.3	2.68
110	12	4,680	49,500	37.8	1.90

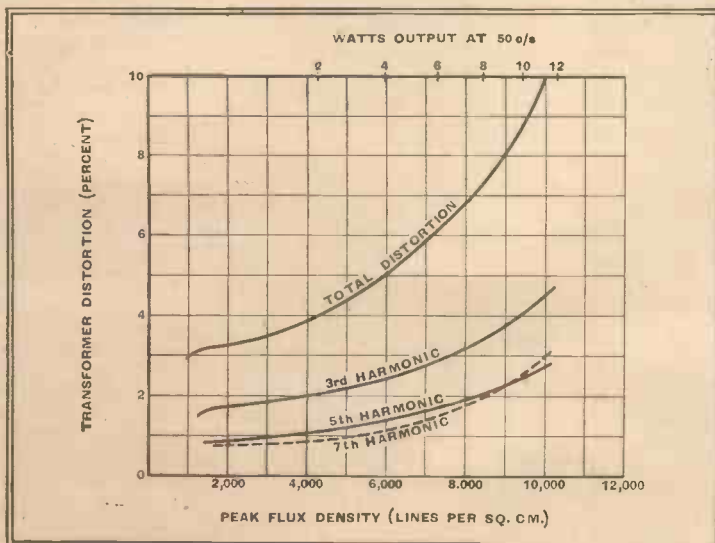

flux density it is easy to deduce all the other values by reference to Fig. 8. Table 1 shows the impedance at five different values of B . It should be noted that the primary impedance varies between three and four times that of the optimum load and, therefore, the attenuation at 50 c/s will be very small.

Columns 3, 4 and 5 of Table 1 contain the values of x for the third, fifth and seventh harmonics respectively. These are taken directly from Fig. 5. Assuming the ratio of the transformer has been correctly chosen, the anode-to-anode load will be 5,000 ohms. The total valve impedance is also 5,000 ohms ($2,500 \times 2$) and hence R becomes 2,500 ohms. This figure is constant throughout the ensuing

Fig. 9.—The distortion produced at 50 c/s by the transformer described in the text for use with two DO24's in push-pull. Table 1 shows how the figures are calculated.

Distortion in Transformer Cores
calculations, but Z_F is different for each flux density.

Returning to Table 1, columns 6, 7 and 8 with the results of multiplying x by $\frac{R}{Z_F}$ while column 9 shows the total distortion, i.e., the sum of columns 6, 7 and 8. These figures have been plotted in Fig. 9 and the curves so produced tell the whole story concerning the distortion caused by the transformer at 50 c/s. By repeating the calculations similar sets of curves could be derived for any other frequency.

In addition to the flux density scale, a scale of watts has been added to Fig. 9. This is derived by using the formula:—

$$\text{Volts} = \sqrt{\text{Anode Load} \times \text{Watts}} \dots (5)$$

The voltage across the transformer terminals at any output can thereby be calculated and substituted in equation (1) to discover what value of B corresponds to the output in question.

Another very informative graph is shown in Fig. 10. The derivation of this curve may be traced from Table 2. It

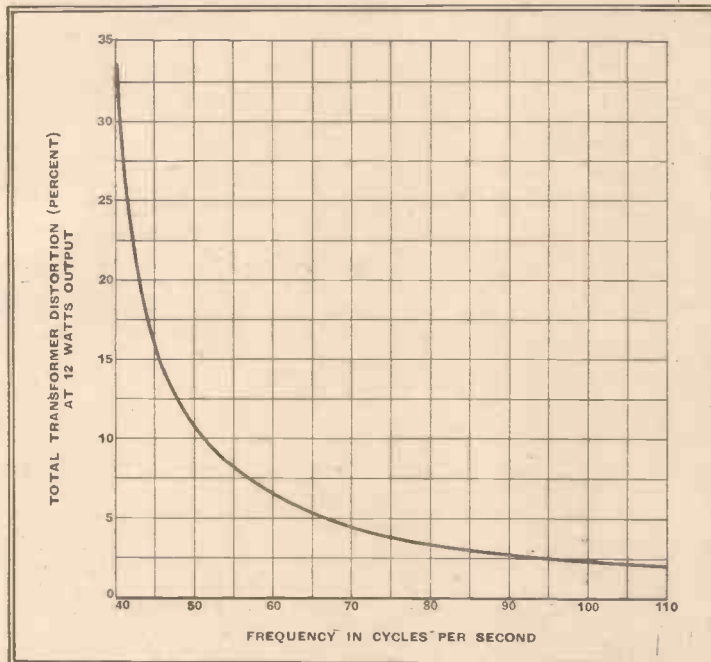

Fig. 10.—Showing how the total distortion at full load varies with frequency. The origin of this curve is indicated in Table 2 and the transformer to which it applies is the same as that analysed in Table 1.

defines the total distortion that would be produced by the above transformer when delivering 12 watts at various frequencies. The total distortion has dropped to $2\frac{1}{2}$ per

TABLE 3

B	Z_F	x from Fig. 5			$x \times \frac{R}{Z_F}$ (R = 4,000 approx.)			
		3rd	5th	7th	3rd	5th	7th	Total
2,000	9,630	11.0	5.3	4.5	4.57	2.21	1.87	8.65
4,000	13,000	17.2	9.5	7.0	5.28	2.92	2.15	10.35
6,000	13,600	22.3	13.1	10.6	6.55	3.84	3.11	13.50
8,000	12,700	27.0	16.0	15.6	8.50	5.03	4.92	18.45
10,000	10,300	31.0	18.7	20.3	12.0	7.26	7.90	27.16
12,000	7,400	35.0	20.0	23.0	19.0	10.8	12.4	42.2

cent. at 90 c/s. But below about 60 c/s the distortion increases very rapidly. This is due to the combined effect of higher flux density and lower impedance (Z_F).

The foregoing outline of the calculations relating

Fig. 11.—High-impedance valves such as tetrodes or pentodes accentuate the transformer distortion. These curves apply to a transformer working in conjunction with two KT66's.

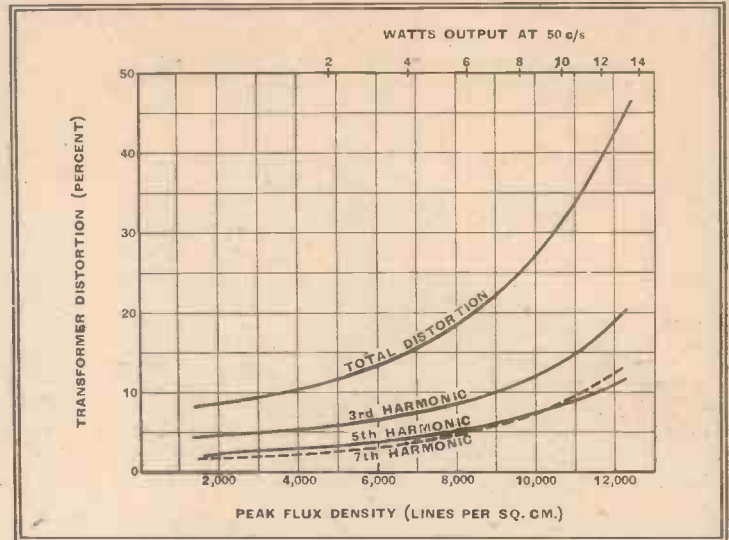

to the problems of iron distortion have, perhaps, made this section of the article a little heavy. The reader is asked to forgive this, because the subject matter is quite new and, therefore, a full explanation

was unavoidable. However, having shown the method, attention can again be turned to the lighter side of discussing the results.

The transformer selected for Example 1 is obviously useless as far as high-fidelity reproduction goes. Somewhere around 10 per cent. distortion at 50 c/s is far more than can be tolerated. But the reader should observe with special care that the transformer would be classed as very good if judged by the normally accepted standards.

Taking the usual "selling points" one at a time we find:—

(1) **Frequency Response.** This is excellent. The primary impedance is three to four times the load impedance at 50 c/s (*The Wireless World* has often recommended a ratio of two as

being adequate), hence the bass is well looked after. The high-frequency response depends only upon the method of winding the bobbin and can be taken as level up to 20,000 c/s for the sake of argument.

(2) **Ratio.**—Our calculations have assumed that the ratio was exact.

(3) **Resistance of Windings.**—The primary resistance would be in the region of 80 ohms total, which is commendably low for an optimum load of 5,000 ohms.

Defining Performance

The author has frequently made derogatory remarks concerning the present craze for lauding frequency response as a proof of excellence. And here we have a typical example of its very limited indications. The transformer examined above passes the much vaunted "straight line" test with flying colours, in spite of being in fact a very third-rate article.

Obviously, additional tests are indispensable. A statement of harmonic distortion is imperative for the purpose of comparing the merits of various output transformers. The author suggests that a very simple scheme would be to state the total percentage distortion produced at 50 c/s when the transformer is delivering its

Fig. 12.—Illustrating how small the harmonic distortion due to the output transformer can be made by careful design. These curves apply to the 50 c/s performance of a transformer working with two DA30 valves in push-pull.

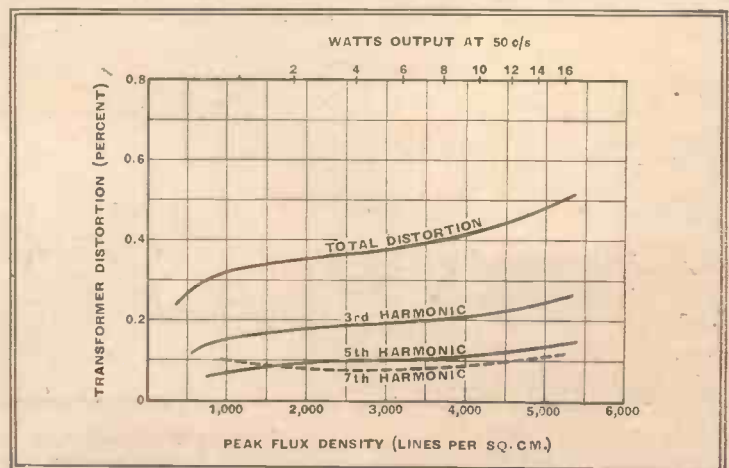

Distortion in Transformer Cores—

full rated output into a resistive load, of value equal to the nominal secondary load. The corresponding figure for the above transformer would be 10.6 per cent. It must be remembered that such a distortion index is arbitrarily chosen and, in order to emphasise this and to avoid confusion with other possibilities, it will be referred to as the "Partridge Distortion Index."

Example 2.—As a second example we will try two KT66 valves in push-pull, operating with an anode-to-anode load of 4,000 ohms. The AC resistance is very high (about 25,000 ohms each) and the output 17 watts.

Again keeping the No. 4 stampings and winding 1,700 turns upon a 1in. stack, the impedance will be as indicated in Table 3. The distortion curves are reproduced in Fig. 11, which corresponds to Fig. 9 of the previous example, and it can be seen that the Partridge Distortion Index is too high to be estimated. Note that once more the frequency response curve would proclaim the transformer as good.

It will be appreciated from this example that high impedance tetrodes and pentodes accentuate transformer distortion. With

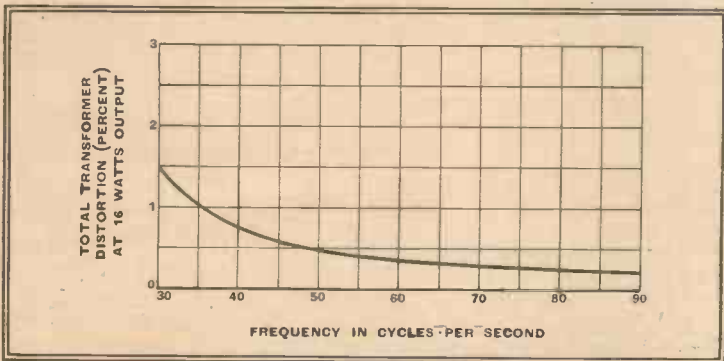

Fig. 13.—These curves relate to the same transformer as Fig. 12 and show how the distortion at full load varies with frequency.

tetrodes the value of R is usually considerably less than that of the optimum load because of the effect of the AC resistance of the valve. In the present case R is approximately equal to the optimum load since the valve impedance is too large to have much effect.

Example 3.—As a final illustration which can be taken as representative of good design, a transformer for use with two DA30's will be described. These valves require an anode-to-anode load of 9,000 ohms in Class "A," and give a speech output of 17 watts.

The transformer uses a 1½in. stack of No. 4 stampings and is wound with 4,400 turns on the primary. Fig. 12 shows the distortion at 50 c/s. In this case the Partridge Distortion Index is

0.5 per cent, which is very satisfactory. In Part IV of this series it will be shown how even better results are possible by using a different magnetic material and a modified design technique. Fig. 13 shows how the distortion at full output varies with frequency and corresponds to Fig. 10 relating to Example 1.

When reviewing the latter curve (Fig. 13) it must be borne in mind that the full output at

Fig. 15.—At (a) is shown Fig. 14 (c) inverted. It is analogous to the usual valve circuit illustrated at (b).

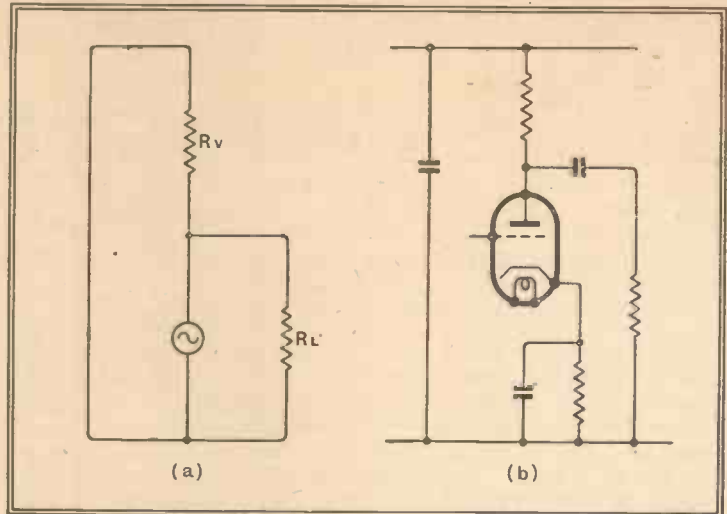

30 c/s can never be expected in normal use. If the full output is devoted to one frequency, nothing can be superimposed upon it without overloading the output stage.

But music consists of many frequencies all reproduced at one and the same time. Hence the amplitude of the bass notes must be small compared with the maximum amplitude permissible. In the opinion of the writer the distortion on full load at 50 c/s can be taken as the maximum

distortion likely to be encountered in practice.

As a parting reflection, how can the obvious superiority of the transformer described in Example 3 be detected by the tests usually applied to this type of component? Clearly it would be judged as simply another good transformer. What further proof is necessary to demonstrate

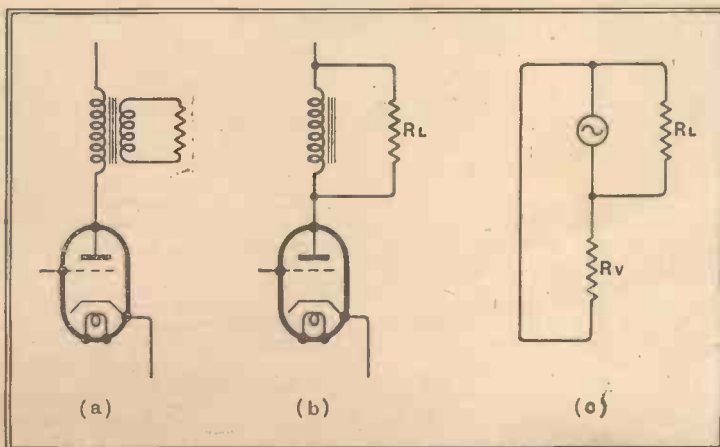

Fig. 14.—Circuit (a) is the usual output transformer diagram which can be represented as at (b) by suitably choosing the value of RL. (c) is the equivalent of (b) if the transformer is considered as a generator.

APPENDIX

To prove that the percentage distortion produced by an output transformer is equal to

$x \times \frac{R}{Z_F}$, consider the output transformer as a generator of harmonics. Fig. 14 (a) can be reduced to Fig. 14 (b), which is equivalent to Fig. 14 (c). Next, turn Fig. 14 (c) upside down. This has been done in Fig. 15 (a) and the similarity between this and the usual valve circuit of Fig. 15 (b) becomes at once apparent.

Falling back upon the well-known valve calculations, the harmonic voltage appearing across the load will be:—

$$V_H \times \frac{\text{External Impedance}}{\text{Generator Impedance} + \text{External Impedance}} \quad (6)$$

where V_H is the open circuit harmonic voltage. Let Z_F = primary impedance to fundamental frequency.

I_F = value of current at the fundamental frequency.

Z_H = primary impedance to any specified harmonic.

V_H = internally generated voltage of specified harmonic.

x = harmonic current produced by V_H expressed as a percentage of the fundamental current (I_F) when the external impedance is zero. Values of x were given in Fig. 5.

V_H = short circuit current \times primary impedance.

$$= \frac{x}{100} I_F \times Z_H$$

$$\text{Normal External Load} = \frac{I}{\frac{I}{R_L} + \frac{I}{R_v}} = R \text{ (say)}$$

(see Fig. 15 (a).)

$$\text{Total impedance of the circuit} = R + Z_H = Z_H \text{ approx.}$$

(see Fig. 15 (a).)

This approximation is justified in normal cases because Z_F is at least equal to R in any reasonably well-designed transformer, and Z_H will be several times Z_F since impedance increases almost in proportion to frequency. The addition of R and Z_H must be vectorially performed and is numerically approximately equal to $\sqrt{R^2 + Z_H^2}$ which is nearly equal to Z_H because Z_H^2 is large compared with R^2 . Therefore:—

Harmonic voltage across load by substitution in equation (6)

$$= \frac{x}{100} I_F Z_H \times \frac{R}{Z_H} = \frac{x I_F R}{100}$$

$$\text{Fundamental voltage across load} = I_F Z_F$$

Therefore the harmonic voltage appearing across the load expressed as a percentage of the fundamental voltage becomes:—

$$\frac{x I_F R / 100}{I_F Z_F} \times 100 = x \frac{R}{Z_F}$$

Distortion in Transformer Cores—
the immediate necessity for a statement of the Partridge Distortion Index or some other figure that will serve as a reliable guide? It is the only way the genuine article can be distinguished. A "straight

line" response is not a passport to the land of high fidelity. The elimination of harmonic distortion serves a more useful purpose than the retention of frequency bands beyond the range employed for radio or gramophone.

knowing where they are from) identifying a particular transmission which removes all doubt of the call sign having been misread. Particulars are appended to this letter, but not for publication.

As one of the pioneers of amateur radio in this country I maintained my transmitting licence until last year, although I have had no transmitter in operation for several years. As a result of this repeated infringement and the inability of the Post Office, in spite of frequent notifications from me, to track down the infringer, I gave up the licence in question, and shall therefore be glad if readers of *The Wireless World* will delete my name from their list of call signs. At the same time I would like to repeat that, if the infringer is identified, I shall consider it my duty to other experimenters who abide by the regulations, to give all the assistance in my power to the authorities in any prosecution which may be decided upon. I will also take independent action if possible.

PERCY W. HARRIS.

Wimbledon, London, S.W.19.

Letters to the Editor

A.R.P. and the Amateur

TO the initiated, the value of portable or fixed wireless sets for maintaining communication under difficult circumstances during emergencies is so well known and appreciated that it seems unnecessary for its advantages to be stressed, but despite that fact the Home Office still sets its face against the employment of radio in A.R.P. communications. It is quite obvious that the first bomb may deprive a town completely of its line communications and render practically the whole of its A.R.P. service useless. The extra strain put upon the much-vaunted loop lines, which in their turn may also be put out of action or destroyed, would not solve the problem, and the use of runners or cyclists through shrapnel-infested streets, probably made impassable by bomb craters to wheeled traffic, may possibly only add to the list of killed or wounded and still fail to bring help to the stricken area. Small portable transmitter-receivers could and would maintain reliable communication under all conditions except that of a direct hit without endangering one extra life. The necessary training could be given by members of the transmitting fraternity, say under the auspices of the Radio Society of Great Britain, who could organise those members willing to help, either as operators or to train personnel.

Thus the Home Office would have the use of a body of men who could, if unlikely to be called up for other services, maintain control or controlled stations at their homes, or use portables as required. Others who have become members of the fighting Services, or who would be in line for such Services in the event of war, could help in the training of additional A.R.P. helpers.

I was interested to see that the police have taken such a course, and are installing wireless apparatus in every police station in the metropolitan area. What about forming a section of the "Specials" to include amateurs who would be prepared to operate the sets?

The Home Office has a fund of useful material at its very door, but unless they wake up before the advent of war it will be too late to take advantage of that fact. Many members of the amateur fraternity, though adverse to war and all its causes, would not hesitate to assist in the protection of their homes; and many too old for more active service could render valuable assistance as wireless operators. If scattered, it would be difficult to re-form the ranks, and their usefulness would probably be spent in less valuable work. Let the Home Office awake to its responsibility.

W. E. F. CORSHAM (G2UV).

Wembley, Middlesex.

Qualifications of Service Personnel

MAY I ask Mr. G. L. Morrow to qualify his statement "that a high standard of technical knowledge in the Services is unnecessary and even undesirable"?

The Editor does not necessarily endorse the opinions of his correspondents

Radio development is very active in the Services just now, and, let us hope, will continue to be so.

How, then, are operators, suddenly confronted with new sets embodying new designs and principles, going to be able to operate, maintain and modify them if they lack sufficient fundamental knowledge to enable them to keep abreast of such development?

Also, Mr. Morrow lays stress on the use of analogies, whereas anyone who has tried to learn radio theory by such evasive methods knows only too well their ability to "lead one up the garden path."

And, sir, if we are to believe Mr. Morrow, the radio branches of the Services are peopled by automatons whose brains respond to morse symbols, but shy like a startled faun when confronted with anything more formidable than $I = \frac{E}{R}$. Are we to assume, therefore, that the pages of *The Wireless World* are looked upon as a foreign journal by such people?

Men leaving the Services and seeking positions in the radio profession will surely object to any such inference, whilst serving personnel will just as surely deplore the obvious insinuation that their ability to assimilate knowledge is strictly limited.

In conclusion, may I congratulate Mr. Morrow on having found such a comfortable armchair from which to air his views?

Cranwell, Lincs. J. CLARKE, Cpl.

News from Japan

THE following may be of interest to those of your readers owning SW receivers and able to take down morse:—

"Domei English broadcast, European zone, 8 G.M.T. Starting Wednesday, June 21st, Station Tokio Oyama; call sign JUQ; frequency 18,080 kc/s."

This announcement was given at the conclusion of the English broadcast on June 20th from JUP on 23 metres at approximately 13.00 G.M.T. Speed about 20 w.p.m. Sunderland. A. HARGREAVES.

Pirate Transmitters

A YEAR or more ago you were kind enough to publish a letter from me notifying readers of *The Wireless World* that my call sign G2MQ was being wrongfully used by some unauthorised transmitter. The publication of the letter (in which I indicated that I was taking legal action against the person concerned, if found) brought about an immediate cessation of the activities of the pirate in question, but they have apparently started again, for this morning I have received a QSL card from two different parts of the world (I do not wish to give the pirate the satisfaction of

Frequency Modulation

FROM the point of view of a purist in nomenclature, "Heptode" (*The Wireless World*, June 15th) is perhaps right in saying that frequency modulation is a different thing from phase modulation; but in actual practice the name frequency modulation is given to a process that is nothing more nor less than simple phase modulation. The definition of frequency modulation, quoted by "Heptode" from J. E. Young's "Electric Communications and Electronics," has nothing to do with frequency modulation as dealt with by radio engineers or radio physicists.

He says that a single frequency current can be expressed as

$$i = A \sin(2\pi ft + \theta),$$

where A is the amplitude, f is the frequency and θ the relative phase. Then he says that if f is slowly varied the wave is said to be frequency modulated. The discussion below shows that this kind of modulation does not occur in practice.

Suppose f is varied slowly by replacing the constant f by a variable $f(1 + k \sin 2\pi Ft)$. F is the frequency of modulation of f and is assumed small compared with f; k can be regarded as the modulation depth of f and may be assumed small compared with unity. The current now is

$$i = A \sin(2\pi ft + \theta + 2\pi kft \sin 2\pi Ft).$$

By sketching a graph of the argument,

$$2\pi ft + \theta + 2\pi kft \sin 2\pi Ft,$$

it is not hard to see that this new value of i is a function oscillating between positive and negative values, the number of such oscillations per second increasing indefinitely with time. The reason for this behaviour is that since f in the original expression for i was multiplied by the time t, the variation is also multiplied by t and becomes greater and greater as time goes on. In other words, the radio engineer looking at this current, either on an oscillograph or with tuned circuits, would say that its frequency was increasing with time without limit. It is hardly necessary to add that the radio engineer never does look at such a current.

Young's definition of frequency modulation is thus quite academic. It is easy to show that phase modulation, as defined by him and by others, is what radio engineers, and their tuned circuits, commonly regard as frequency modulation.

PRO BONO RADIO.

Farnborough, Hants.

Alexandra Palace Television Service Area Map

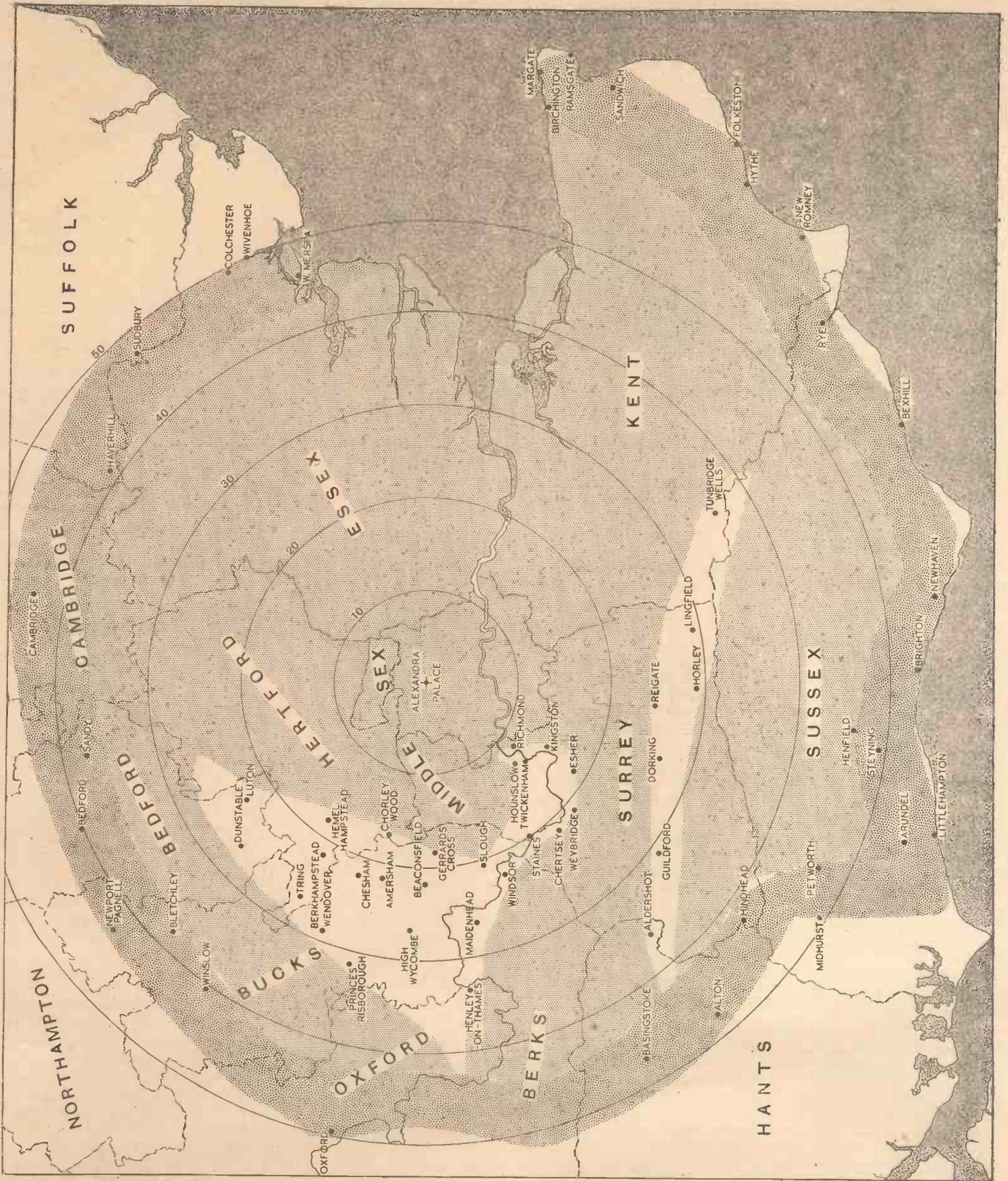

This map, based on one prepared by the R.M.A., covers the area in which reliable reception can be expected from the London Television Station. The dark shaded band represents the boundary of the area in which consistent reception is usually obtained under average conditions, while in the areas inside this zone shown in white reception is usually satisfactory but difficulties may be experienced due to local conditions. The concentric circles represent 10-mile steps. Copies of the larger and more detailed R.M.A. map, printed in colours, are obtainable at 2/6 each from the Radio Manufacturers' Association, 59, Russell Square, London, W.C.1.

Magnetic Television

Part I.—CHARACTERISTICS OF MODERN APPARATUS

By

W. T. COCKING

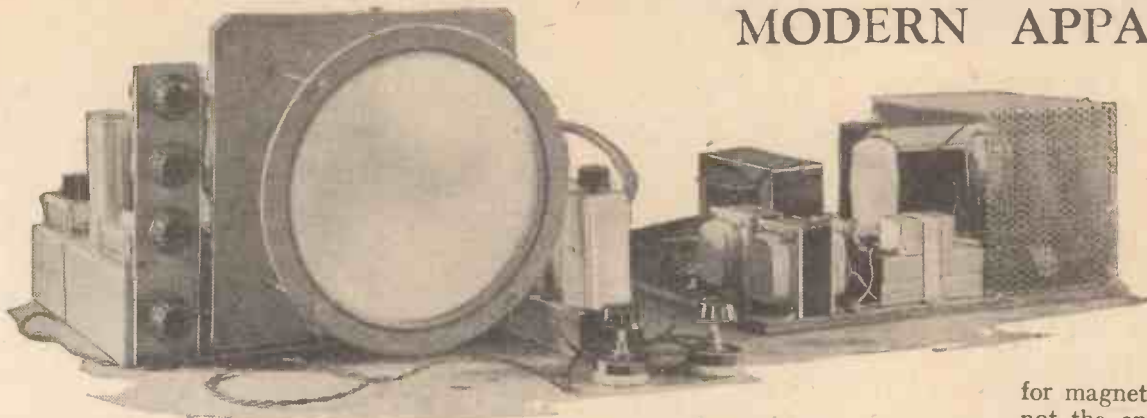

THE word receiver is greatly over-worked nowadays, for it is commonly used to cover the whole receiving equipment instead of being retained with its earlier meaning of the apparatus between aerial and loud speaker. The loud speaker and mains equipment are now considered part of the receiver, and in television the term includes the cathode-ray tube, the scanning circuits, the power supply, and often the sound equipment, as well as the receiver proper.

It is often difficult to avoid this double meaning, but in these articles it will generally be used in its narrower sense to denote that part of the apparatus which takes the signal from the aerial, selects and amplifies it, and puts it into a suitable form for modulating the CR tube and synchronising the time-base oscillators. Its function is thus exactly analogous to a sound receiver, and in fact, it differs only in detail and not in principle. The CR tube, of course, corresponds to the loud speaker of sound equipment.

In television, however, there is apparatus which has no analogy with sound reproduction. This is the time-base and scanning gear. The purpose of this is to make the spot on the screen of the CR tube move regularly over the screen in exact accordance with the evolutions performed by the scanning beam in the transmitting camera.

Enormous variety in the type of television receiving equipment is possible. In considering its design the first step is to make a choice between the electrostatic and electromagnetic types of cathode-ray tube. Both need a similar final anode potential of the order of 3,000-6,000 volts, but, if anything, the magnetic tube can do with the lower voltage. This tube also needs only the single high-voltage supply, for focusing is accomplished by passing current through a coil which surrounds the neck of the tube. This current can be derived from the receiver or time-base HT supply. With electrostatic focusing, no coil is needed, but potentials must be

applied to electrodes built into the tube. In general, about 200-400 volts is necessary for the first anode and about 800-1,500 volts for the second. As these voltages are derived from the main high-voltage supply, it must be better smoothed than in the case of a magnetic tube.

As regards focusing apparatus there is really very little to choose between the two. For the electrostatic tube it is necessary to provide three different voltages, of which one must be accurately adjustable, with a fairly high degree of smoothing. With an electrostatic tube only one high voltage is needed and it requires little smoothing. To offset this it is necessary to provide a focusing coil, current for it, and a means of adjusting the current accurately.

Magnetic or Electrostatic Deflection?

Turning now to deflection, saw-tooth oscillators are needed in either case. With the electrostatic system two pairs of deflector plates at right-angles are built into the tube, and for deflection something like 1,000 volts p-p. of saw-tooth voltage waveform must be applied in push-pull to each pair. This usually means a pair of push-pull triodes between each saw-tooth oscillator and each pair of deflection plates. Quite a large number of high-voltage condensers are needed, and the time-base HT supply must be of the order of 1,000 volts at some 20 mA.

With magnetic deflection the usual arrangement is to mount two pairs of coils at right-angles round the neck of the tube and to pass saw-tooth current waveforms through them. The usual procedure is to employ a pentode amplifier between each saw-tooth oscillator and each pair of deflector coils, the coils being fed through a suitable transformer. Fewer valves are needed, and the HT supply may be 120 mA. or so at 300 volts only. Certain components and valves, however, must be built to withstand voltages of the order of 3,000, which occur on the line fly-back.

This is not the only system available

for magnetic deflection and, in fact, it is not the one employed in the equipment to be described later in this article. Here no amplifiers are used and the deflector coils are part of the saw-tooth oscillators. This leads to economy of HT current consumption, but, as will be seen later, leads to no saving in the number of valves.

In a comparison between the two systems the balance is probably in favour of magnetic deflection so far as cost is concerned, but in the design of the equipment electrostatic deflection is unquestionably the easier. In regard to the ease of setting up the apparatus to follow a given design, there is less to choose, but electrostatic deflection is rather the easier of the two. There is, however, no serious difficulty with magnetic.

We now come to the all-important matter of performance. Here there can be very little doubt that magnetic focusing and deflection score over electrostatic. In general, and for a given anode voltage and standard of definition, the magnetic tube gives a brighter picture than the electrostatic.

Apart from the saturation characteristics of the fluorescent screen, brilliancy increases with the anode voltage and the spot size tends to decrease, thus permitting better definition. The spot size obtainable, however, depends also on the electron density of the beam, or the beam current, and the method of focusing. The brilliancy also depends on the beam current. It consequently pays better to use a method of focusing which permits the required spot size to be obtained with a large current than one with which the spot size can be obtained only with a small current.

Magnetic focusing permits the use of a heavier beam current than electrostatic focusing, so that a more brilliant picture can be obtained for the same voltage. In deflection, too, the magnetic tube scores. The deflector plates of the electrostatic tube tend to affect the focus at large deflection angles, with the result that while the spot may be perfectly focused over the centre of the picture, it may be very badly focused at the edges. More-

Receiver

over, quite small misalignment of the electrodes can seriously affect the shape of the spot—instead of being round, it may be drawn out into a line.

All these defects can occur with magnetic deflection, but they are much more readily controllable. Since the coils are all outside the tube, they can be centred precisely, if the user cares to take the trouble. In general, with good design of the coils and no extreme care in setting up the coils, focusing defects are not completely absent, but are very much less than with electrostatic deflection.

There is thus no doubt but that it is desirable to choose the magnetic type of tube, and the next thing is to decide on its size. This depends only on cost and the viewing distance. The larger the tube the more the apparatus costs, not only because the larger tube is itself more expensive but also because it is likely to need a higher voltage for the same brilliancy. This in turn calls for more deflecting power, so that the cost of the time-base goes up. Further, the larger tube must be provided with a larger cabinet.

Viewing Distance

From the point of view of performance the optimum size of tube depends entirely on the viewing distance and is actually proportional to it. Experience shows that with a 12-in. diameter tube, giving a picture about 10in. by 8in., the optimum viewing distance is 5-6ft., and the picture is then roughly the equivalent in apparent size to that obtained in a good seat in an average cinema. Tubes are obtainable in sizes from about 5in. to 16in. diameter, so that viewing distances similarly vary from some 2ft. to 8ft.

In general, a viewing distance of about 4ft. to 5ft. would seem to meet most domestic requirements. A greater distance than this may be inconvenient in the small rooms of modern houses. In any case, it is better to err on the small side rather than on the large, since it is not only cheaper but it is easier to go nearer the picture than to get further away. The front of the set will stand from the wall of the room at least 2ft., so that in viewing one's eyes will be 6-7ft. from one wall.

The arrangement of furniture in a room is usually such that one's head is at least 2-3ft. from the wall when sitting down, so that for a viewing distance of 4-5ft. the room should not be smaller than 8-10ft. in one dimension. This is the minimum for convenient viewing, and in practice a 4-5ft. viewing distance works out about right for a room which is 10-15ft. across. For such a distance a tube of 9-10in. diameter is correct.

We thus find that for the average

IN the series of articles of which this is the first full details will be given of a modern television receiver which has been developed in the "Wireless World" Laboratory and which has proved capable over an extended period of giving an extremely good picture. It is felt that these articles will prove serviceable in demonstrating in practical form the points discussed in earlier theoretical articles, even to those whose interest in television is more theoretical than practical, while the data given will be adequate to enable any proficient constructor to build a replica.

modern room a 9-in. tube is about the optimum; for larger rooms a 12-in. tube is desirable, while the 16-in. tubes meet the requirements of unusually large viewing distances. Cost is almost always the sole consideration when a tube smaller than 9in. is selected, as it is comparatively seldom that the viewing room is so small as to render desirable the use of a smaller tube.

Incidentally, it should not be thought that the relation between tube and room size is in any way critical. It is not, as the wide variations in viewing distances in a cinema show. There is always an optimum distance, but quite a wide latitude is permissible. If one is too far from the television picture, then detail will be lost, while if one is too near the line structure will be obvious and the definition may seem poor. If one cannot be at the correct distance it is usually better to be too far away than too near.

We thus choose a 9-in. magnetic tube as best meeting our requirements, and of the various types listed of similar performances we choose one which is readily available and for which deflector and focusing coils are easily obtainable. For this equipment the Baird tube has been selected and it is used with Baird coils. This in turn necessitates the use of an unusual, but economical, time-base circuit for which the coils are designed. This will be described in greater detail later.

Turning now to the receiver, it must provide an output sufficient fully to modulate the tube. This is about 20 volts p-p. of vision signal, but the output must be greater than this to allow for the sync pulses; the total output must be nearly 30 volts p-p. The DC component of the vision signal must be retained if the mean illumination of the picture is to be reproduced correctly, and its retention is, of course, essential for sync separation. In order to obtain good definition, modulation frequencies up to 2 Mc/s or more must be retained and phase distortion must be kept at a minimum.

The degree of sensitivity needed depends entirely upon the district in which the apparatus is to be used and upon the efficiency of the aerial system. In the suburbs around Alexandra Palace a very strong signal is obtained and quite a modest receiver will suffice. For distances of 5 to 10 miles, however, a moderately sensitive receiver is needed, and outside this distance the sensitivity required goes up quite rapidly with distance.

Long-range Reception

At more than about 30 miles it is not possible to guarantee reliable reception, no matter how sensitive the receiver is.

Good results are obtained every day at distances much greater than this, but in a new district one cannot say whether or not it is possible without trying it. In one place 70 miles or so from the transmitter good reception may be consistently obtained; at another place, perhaps, only 40 miles away, the same receiver may only produce a poor picture.

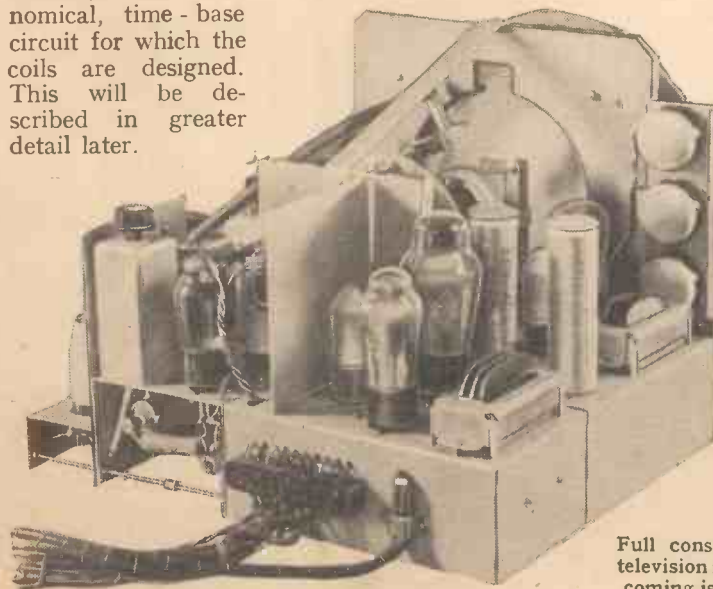

Full constructional details of this television receiver will appear in forthcoming issues of *The Wireless World*.

Magnetic Television Receiver—

So much depends on the nature of the country lying between transmitter and receiver that it is difficult to foretell whether good results are likely to be obtained at any great distance or not. In any case the aerial is very important.

In order to cater for the needs of as many as possible it was decided to make this receiver of a highly sensitive type. The sensitivity is actually unnecessarily high for those near Alexandra Palace, but it is much easier to omit a stage if desired than to add an extra one.

LIST OF PARTS

RECEIVER.

1 Aerial coil, 45 Mc/s	Peto-Scott VIA
1 RF coil, 45 Mc/s	Peto-Scott VIR
1 Oscillator coil, 58 Mc/s	Peto-Scott VIO
4 IF coils, 13 Mc/s	Peto-Scott VIIF
Fixed condensers:	
3 10 mmfds., ceramic	Dubilier CDS3
2 0.001 mfd., mica	Dubilier 690W
11 0.01 mfd., mica	Dubilier 691W
1 0.02 mfd., tubular	Dubilier 4601/S
2 0.1 mfd., tubular, 350 V	Dubilier 4603/S
1 0.25 mfd., tubular	Dubilier 4606/S
Resistances:	
1 50 ohms, $\frac{1}{2}$ watt	Erie
2 100 ohms, $\frac{1}{2}$ watt	Erie
3 150 ohms, $\frac{1}{2}$ watt	Erie
1 200 ohms, $\frac{1}{2}$ watt	Erie
3 500 ohms, $\frac{1}{2}$ watt	Erie
1 1,500 ohms, $\frac{1}{2}$ watt	Erie
1 2,000 ohms, $\frac{1}{2}$ watt	Erie
2 4,000 ohms, $\frac{1}{2}$ watt	Erie
6 5,000 ohms, $\frac{1}{2}$ watt	Erie
1 6,000 ohms, $\frac{1}{2}$ watt	Erie
2 10,000 ohms, $\frac{1}{2}$ watt	Erie
1 15,000 ohms, $\frac{1}{2}$ watt	Erie
1 25,000 ohms, $\frac{1}{2}$ watt	Erie
2 50,000 ohms, $\frac{1}{2}$ watt	Erie
1 75,000 ohms, $\frac{1}{2}$ watt	Erie
2 1 megohm, $\frac{1}{2}$ watt	Erie
1 65,000 ohms, 1 watt	Erie
1 3,500 ohms, 2 watts	Erie
1 Potentiometer, wire-wound, graded, 15,000 ohms	Reliance "TW/G"
1 RF choke	Eddystone 1011
1 Coil, 144.5 μ H	Wearite PO7
1 Coil, 37.5 μ H	Wearite PA6
7 Plug-top valve connectors	Belling-Lee 1175
6 Valveholders, British octal, chassis mounting	Clix XIIIO
1 Valveholder, 7-pin, chassis mounting	Clix XII2
1 Valveholder, 5-pin, chassis mounting	Clix XIII
2 Valveholders for Mazda Di	Belling-Lee 357/H
Chassis, aluminium	Peto-Scott
2 yards G.E.C. twin-core 110/.0076	Domestaflex
Domestaflex	Peto-Scott W9404
Valves:	
5 SP41, 1 SP42, 1 ACTH1, 2 Di	Mazda
1 354 V	Mullard

TIME BASE.

1 Scanning kit, including focus coil, frame yoke, frame choke, line deflector coils and shroud, line scanning transformer	Baird
1 Potentiometer, 0.5 megohm	Reliance "Compo SG"
1 Potentiometer, 50,000 ohms, wire-wound	Reliance "TW"
1 Potentiometer, 20,000 ohms, wire-wound	Reliance "TW"
2 Potentiometers, 2,000 ohms, wire-wound	Reliance "TW"
Condensers:	
1 0.001 mfd., tubular	T.C.C. 451
1 0.0025 mfd., 2,000 V., tubular	T.C.C.
1 0.1 mfd., tubular	T.C.C. 341
1 0.25 mfd., tubular	T.C.C. 341
3 0.5 mfd., tubular	T.C.C. 341
2 8 mfd., 150 V	T.C.C. "FT"
2 8 mfd., 450 V	T.C.C. 802
1 50 mfd., 12 V, electrolytic	T.C.C. "FT"

Resistances:

1 1,000 ohms, $\frac{1}{2}$ watt	Erie
1 10,000 ohms, $\frac{1}{2}$ watt	Erie
1 20,000 ohms, $\frac{1}{2}$ watt	Erie
1 50,000 ohms, $\frac{1}{2}$ watt	Erie
1 100,000 ohms, $\frac{1}{2}$ watt	Erie
1 0.5 megohms, $\frac{1}{2}$ watt	Erie
1 1,000 ohms, 1 watt	Erie
1 20,000 ohms, 1 watt	Erie
1 2,000 ohms, 2 watts	Erie
1 20,000 ohms, 2 watts	Erie
1 Connector, 10-way	Bryce 5C6
3 Wander plugs	Clix MPI
5 Valveholders, 5-pin high-voltage	Belling-Lee 352/5
Chassis and tube mounting	Peto-Scott
Valves:	
2 2D4A, 1 UR1C	Mullard
1 AC/P	Mazda
1 41MP	Cossor
1 Magnetic tube, 9in.	Baird

POWER UNIT.

1 Mains transformer	Partridge WW/T2
Primary, 200-250 V; Secondaries, 350-0-350 V, 120 mA, 4 V 2.2 A, 4 V 3.5 A, 4 V 8 A	
1 Mains transformer	Partridge WW/T1
Primary, 250 V; Secondaries, 3,000 V 0.5 mA, 20 V 0.2 A, 4 V 0.65 A, 2 V 2.5 A	
2 smoothing chokes, 10 H, 120 mA, 200 ohms	Sound Sales H10/120
Condensers:	
1 4 mfd., electrolytic, 500 V	B.I. E.C.S.20
2 8 mfd., electrolytic, 500 V	B.I. E.C.L.40
1 0.1 mfd., 4,500 V tubular	B.I.
Resistances:	
1 1,000 ohms	Bulgin PR5
1 50,000 ohms, $\frac{1}{2}$ watt	Erie
6 3 megohms, $\frac{1}{2}$ watt	Erie
1 200 ohms, 20 watts	Bulgin PR24
1 Valveholder, 4-pin	Clix XII11
1 Valveholder, British octal	Clix XII28
1 Connector, 10-way	Bryce 5C6
1 Connector, 5-way	Bryce 5C4
1 Connector, 2-way	Bryce 5C1
1 Fused plug, 2A fuses	Belling-Lee 1114
1 Terminal	Belling-Lee B1001
Baseboard, panel, etc.	Peto-Scott
Valves:	
1 HVR2	Mullard
1 UU7	Mazda

Two New Cossor Sets

A. C. COSSOR, LTD., have recently added two new receivers to their range. They are the Model 33 battery superhet with push-button tuning, and the Model 62 AC console receiver.



The new Cossor Model 62 AC console receiver.

The latter, at 11 guineas, is housed in a walnut cabinet of striking appearance, and

makes use of a wide-response 8-inch moving-coil loud speaker. There are four valves + rectifier in the superheterodyne circuit, which covers three wavebands (16-52 metres, 190-580 metres, and 840-2,150 metres).

There are four valves in the superhetero-

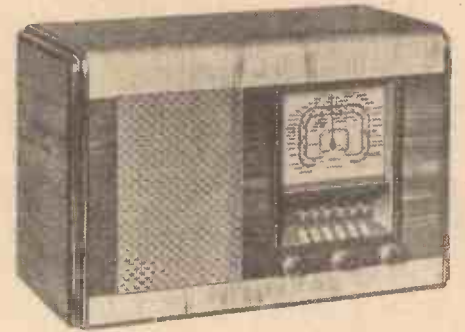

Cossor Model 33 battery receiver with push-button tuning.

dyne circuit of the battery model, which covers approximately the same wavelengths. The final valve is a high-slope "economy" pentode, and grid bias is automatic. A mechanical push-button system is employed, and station adjustment may be effected from the front of the receiver. The price of the Model 33 is 9 guineas.

PROBLEM CORNER—26

An extract from Henry Farrad's correspondence, published to give readers an opportunity of testing their own powers of deduction:—

"Bellevue,"

Hampstead, London, N.W.3.

Dear Mr. Farrad,

Thank you for helping me to identify the mysterious short-wave news bulletins; you are evidently quite right in tracing them to the television station. Now I have another problem, and hope you will be equally successful with it. For the last week or so I have been bothered with whistles on the medium waveband. Up till then it has been very free from whistles, the only strong one being on Milan, due, I understand, to the second harmonic of London Regional coming in on the second channel. Only certain stations seem to be affected—the worst are Brussels No. 2 and Radio-Lyons (not Lyons PTT), and a little cluster of stations around each have whistles, but only when not dead in tune. Now that the evenings are light until fairly late it is only towards the end that most of the whistles are noticeable. But until recently I didn't get them at all, light or dark.

The set, as you remember, is an all-wave model, and has an RF stage, a frequency-changer, IF and double-diode-output-pentode, besides the rectifier; and I have a very good aerial, so I get as good results as most sets with more valves.

The whistles don't bother me very much, but as they started so suddenly it seems to me that they may be due to some slight fault that has developed and could be put right if you could give me some idea of where to look.

Yours sincerely,

Will B. Keen.

What are the whistles due to, and where should Mr. Keen look for the cause? Solution on page 612.

NEWS OF THE WEEK

PROVINCIAL TELEVISION

Traders' Deputation to the P.M.G.

MAJOR TRYON, the Postmaster-General, last week received a deputation organised by the Radio and Television Traders' Federation which urged the speedy extension of the television service to the provinces and Scotland.

The deputation not only stressed the necessity for this extension, but, emphasising the fact that radio and television were two distinct forms of entertainment, stated that they were voicing the demand of the public for the new form of entertainment. Moreover, if the British television industry was to maintain its present lead in this field, the service must be extended.

£1 Licence Suggested

If the difficulty in the way of such an extension was a financial one, then the deputation proposed that a new licence should be introduced for the radio and television services at a combined fee of £1 per annum—the existing 10s. wireless receiving licence to remain. It was felt that the public would be prepared to pay for this additional form of entertainment.

Television Committee's Report

The deputation urged the provision of one provincial television station this year, two further stations by the end of 1940, and an 85 per cent. coverage by 1942. The Postmaster-General stated in reply that the Television Advisory Committee had been investigating the problem in all its aspects, and he understood that they were about to submit him a report on the subject. He promised that in considering the report he would give full weight to their representations.

QUESTIONS IN THE HOUSE

The Foreign Office and Broadcasting : Electrical Interference : Italian Propaganda

REPLYING on behalf of the Prime Minister to a question in the House of Commons last week, Mr. Butler, Under Secretary for Foreign Affairs, stated that the existing relations between the B.B.C. and the Foreign Office in regard to foreign language broadcasts will undergo no change with the inauguration of the new Department for Foreign Information; that is to say, although responsibility for what is broadcast rests with the B.B.C., it is understood that the Corporation will continue to maintain the closest contact with the Foreign Office and will make full use of the information at the disposal of the Foreign Publicity Department.

In a written reply to another question of a similar nature, Mr. Butler explained that the purpose of the Vansittart Committee was to co-ordinate the work of foreign publicity undertaken by such bodies as the British Council, the British Broadcasting Corporation and the Travel Association, and to bring together such Government Departments as were concerned in this work. The Foreign Publicity Department of the Foreign Office will henceforth be responsible for co-ordinating these activities.

Electrical Interference

Answering a question on electrical interference and its suppression, Major Tryon, the Postmaster-General, stated that about a thousand complaints were received during the year 1938 concerning interference with wireless reception caused by neon sign installations. In most of these cases, the owners of the installations agreed to fit interference suppression devices,

although there was at present no legal power to compel them to do so. Enquiries regarding the possible scope and operation of a new wireless Telegraphy Bill to deal, *inter alia*, with the question of electrical inter-



TREASURE ISLAND'S 20-kW short-wave transmitter, W6XBE. Erected in the Palace of Electricity at the San Francisco Golden Gate International Exposition, it radiates transmissions to the Far East on 9.53 Mc/s., when the path between the transmitter and the destined listening point is dark and on 19.57 Mc/s. when part of the path is light.

ference with wireless reception were being actively pursued. The problem was, however, one of great complexity involving consultations with many interests which would be affected, and Major Tryon said that some time must elapse before these consultations could be completed.

Italian Broadcasts

In reply to another question, Mr. Butler said that the Prime Minister was kept informed of the nature of the broadcasts from Bari. His Majesty's Government have not thought it desirable to address representations to the Italian Government about any recent broadcasts.

SUCCESS OF START POINT

Some Listeners' Reactions

FROM along the south coast as far as the Kent-Sussex border the B.B.C. continues to receive gratifying reports of the reception of Start Point.

A Bosham (Sussex) listener states that Start Point is twice as strong as London Regional, while listeners in South London acclaim it as providing an alternative to London Regional.

The B.B.C. engineers are much encouraged by the fact that these successful results are due to the special aerial arrangement at Start Point,

which is devised to give maximum spread eastwards. At the same time, the west is well satisfied, judging by reports from Penzance and Polperro. The Isle of Wight is also well pleased.

B.B.C. listeners in the densely populated area around Brighton, hitherto very poorly served, report that Start Point now provides them with a reliable alternative programme to Daventry.

Grumbles have come from Wales, however, where many listeners miss the English transmissions from Washford and are apparently expecting equivalent results from Start Point. The new station, however, is not intended for Wales, which should be able to pick up English programmes from Droitwich. In South Wales the new Clevedon station is filling in the gaps.

NEW TELEVISION VIEW-FINDER

A CATHODE-RAY tube view-finder is now being used by the B.B.C. on one of the super-Emitron cameras for outside broadcasts.

Hitherto the task of keeping moving objects in the picture has been a difficult one for the cameraman, as the image is upside down and, when a telephoto lens is used, is exceedingly small. The new view-finder gives the cameraman a perfect check on the picture, as it is seen in the scanning van.

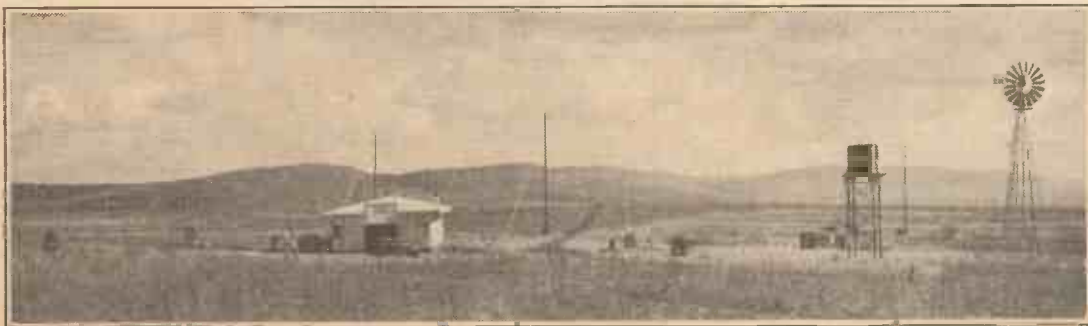

"SOUTH AFRICAN TATSFIELD"—the South African Broadcasting Corporation's diversity receiving station at Panorama, 14 miles from Johannesburg. Three rhombic aerials orientated on Europe are being erected and a series of masts for experimental aerials beamed on other parts of the globe are also contemplated. Mr. Griffiths of the B.B.C. receiving station at Tatsfield, who has been supervising the erection of the station, has now returned to this country.

News of the Week—

Another recent improvement is a new chromium-plated microphone boom which, strapped to an engineer's back, supersedes the unwieldy bamboo pole.

TELEPHONE BROADCASTING

THE Postmaster-General's new scheme for the use of the telephone service as a broadcasting medium has raised the question whether all programmes will still emanate from B.B.C. studios. In official circles it is considered possible that the special studio facilities may be available in Whitehall whence announcements of national importance could be broadcast direct.

The R.M.A. has issued the following statement concerning the P.M.G.'s pronouncement on the projected service:—

The Radio Manufacturers' Association can only reiterate the view expressed some time ago that relay and wired wireless systems are in no way a substitute for the radio receiving set, which gives listeners a wide choice of programmes from all over the world.

In emphasising the case for wired communication in case of emergency, the Postmaster-General seems to have overlooked the lessons of the Great War. It was shown repeatedly that in bombed and shelled areas wired communication was subject to continued interruption and if, as has been frequently stated, large areas are vulnerable from the air, then wired communication may be subject to interruption and the radio link is vital to the maintenance of communication.

The Postmaster-General appears to have overlooked or ignored the importance of radio services as a means of maintaining communication in case of emergency, although it appears to be fully recognised by the Services.

VIEWERS' OPINIONS OF TELEVISION

A "TELEVISION tea party"—the first of its kind, although others are probable—was held in the Concert Hall, Broadcasting House, on Monday. Some 150 regular home viewers from all parts of London and the Home Counties informally met members of the Alexandra Palace staff. Members of the Board of Governors and the Director-General were also present.

After tea viewers were given the opportunity to express their opinions and criticisms regarding the television service and some interesting observations were made.

It was very apparent from the applause given to one suggestion that viewers are not only willing to pay extra for the service, but feel that it is unfair for listeners to bear the cost, and a television licence fee of £1 was suggested.

The question of interference from car ignitions was raised, and one viewer asked the pertinent question—how many car owners in the gathering had suppressors fitted to their own cars.

OBITUARY

DR. ARTHUR EDWIN KENNELLY, Sc.D., Emeritus Professor of Electrical Engineering at Harvard and at the Institute of Technology, Massachusetts, died at Boston last week, aged 77. He was at one time principal assistant in electricity to Edison, and discovered the ionised layer surrounding the earth at almost the same time as Oliver Heaviside. Dr. Kennelly was born at



A PROSPECTIVE BUYER examines the first knockdown television kit placed on the American market by the Andrea Radio Corporation. The makers claim that the set can be constructed by the "average man" in thirty working hours.

Too Many Valves

A MOVEMENT to reduce the number of new valves introduced in the radio industry is being initiated by the American Radio Manufacturers' Association. A good deal of confusion already exists on account of the vast number of types on the American market, and the recent introduction of the 7-pin Loctals has further aggravated the position.

Radio-Tangier Becomes French

FOLLOWING the transfer of the Tangier broadcasting station from Spanish to French interests, it is reported in the *Agence Economique et Financiere* that the station will be transmitting upon lines approved by the French Government towards the end of the year.

More French S-W Stations

IT is announced that at the beginning of 1940 two new 100-kW short-wave stations will be put into service in France. It is further stated that six other short-wave transmitters are to be built which will bring the total number of French S-W stations to nine.

Marconi School

INTENDING applicants are reminded that vacancies at the Marconi School of Wireless Communication, Chelmsford, are limited, and those wishing to attend the session commencing Monday, September 11th, 1939, are advised to make early application. Hostel accommodation can be provided for those wishing it.

Voice from the Wilderness

AUSTRALIAN listeners recently heard a broadcast from Dr. Cecil Madigan's scientific expedition in the Simpson Desert. The expedition had reached the centre of the desert, and relay stations established along the route to Adelaide passed on the transmission from the expedition's "pedal transmitter" to the National Network of the Australian Broadcasting Commission.

Wireless for Small Ships

AT the Board of Trade enquiry into the loss of the 325-ton cargo vessel *Rumore*, which disappeared with a crew of seven in St. George's Channel during January, 1938, the assessors recommend that it should be considered whether such vessels as this, which are not required by law to be fitted with wireless telegraphy apparatus, should not all be equipped with wireless telephony transmitters.

Interference on 6 metres

THE Federal Communications Commission is expected to recommend that all diathermy machines should have adequate filters in their power lines and be confined to one frequency band, so as to cut down interference with broadcasting to a minimum.

O.M.

WHO is the world's oldest amateur transmitter? Writing in *QST* Mr. L. J. Ryan, of Hannibal, Missouri, stakes his claim. He is seventy-eight years old and has been an active operator for twenty-one years.

Finnish People's Set

FOLLOWING a survey of Finnish broadcast listeners, a campaign has been run by Finnish newspapers calling for the provision of a cheap "People's Set" on the lines of the Norwegian and German types which the less well-to-do majority of the population could afford to buy.

New Appointment

SIR CECIL GRAVES, Deputy Director-General of the B.B.C., has been elected Vice-President of the International Broadcasting Union.

School Broadcasting

THE President of the Federal Council of Teachers in Northern Ireland will lead a deputation of school teachers which is to approach the Ministry of Education with a view to extending the facilities for listening to educational broadcasts in their schools.



PORTABLE PA EQUIPMENT used during the recent A.R.P. test in Chelsea. This Grampian "Control" unit is battery or AC operated.

Bombay and received the latter part of his education at University College, London.

FROM ALL
QUARTERS

Radio Relays?

A NUMBER of telephone subscribers residing in the vicinity of the new B.B.C. Bristol transmitter at Clevedon have reported the intrusion of the West Regional programme into their telephone conversations. This is a frequent occurrence in areas adjacent to new transmitters, and can be speedily corrected by G.P.O. engineers.

WANTED— A New Kind of Receiver

EASY TUNING AND WORTHWHILE DX
AT A REASONABLE PRICE

By R. W. HALLOWS, M.A.

BROADLY speaking, only two kinds of wireless set are available to-day—the broadcast receiver and the communication receiver. Admirably as either may do the job for which it is designed, my feeling, after a considerable experience in handling a large number of sets of both these types, is that neither quite meets the needs of the average man who makes long-distance wireless reception his hobby.

Those who do so are a large and growing body. At one time it seemed that this hobby, almost as old as wireless itself, might lose its popular appeal. Before the coming of the various European wavelength plans, the medium-wave and the long-wave bands had drifted into such a state of chaos that there were few foreign stations that one could be certain of receiving well on any given evening. Listening on the short waves to the few regular broadcasting stations that there were was a business altogether too difficult, too fiddling and too trying to the patience for any but hard-bitten, expert enthusiasts. Doubtless you recall your own efforts with those early "straight" short-wave receivers—the hair's-breadth movements that were necessary with the tuning knobs, whose foot-long extension spindles were far from eliminating the effects of body capacity.

Several factors played their part in saving long-distance listening. Successive "plans" introduced sufficient order into the medium waveband to make the reception of a large number of foreign stations free from mutual interference a certainty at any time. Increases in the power of stations enabled far better quality to be

ALL long-distance listeners would like to possess a high-class communication receiver, and many of them do so. There is, however, a large class of listener, whose hobby is listening to really distant stations, to whom the price of one of these de-luxe sets is prohibitive. The ordinary broadcast receiver is inadequate for their purpose, and in this article practical suggestions are made whereby manufacturers could make a suitable long-distance set for about £20, the basis of the design being the communication receiver in which all the non-essentials and de-luxe gadgets have been omitted.

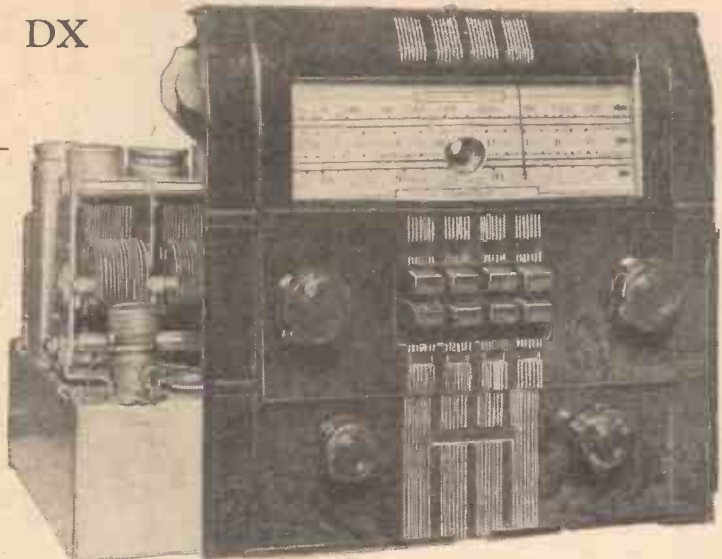

Courtesy Frank Heaver, Ltd.
In this American-made "Colonial" receiver more than usual care is taken, by means of a large, clearly marked dial, to make tuning easy.

obtained with a diminution of background. On the short waves matters improved amazingly. Optimum wavelengths for different times and seasons were found and used; channels were allocated by international agreement; civilised countries all over the world began to transmit regular programmes from high-powered stations; and, finally, the beam system was exploited with the happiest results.

But, in addition to all this, there was the development of the superheterodyne receiver as a moderately priced set suitable for general use. Its sensitiveness, its selectivity, its stability and the simplicity of its controls made it the ideal popular receiver. To-day there is, I suppose, hardly any owner of a wireless set who cannot

tune in some distant stations, and does not occasionally do so. In a sense we are all long-distance listeners now. I am writing, though, not for those who just now and then "run round the dial" to see whether there is anything of interest from abroad on the short or the medium waves—in the "broadcast" superhet, or even in the modern small "straight," they have exactly the instrument that they require. The people whose needs it does not fulfil are those whose pleasure lies in regular long-distance listening, in the capture of new stations as they come into operation, in the keeping of records of their successes and failures, and in observing the variations in reception conditions.

Broadcast Receiver Limitations

First let us examine the "broadcast" receiver through a DX man's spectacles and see where and how it does not fill the bill. To begin with, it is a mass of compromises. In their laudable efforts to combine reasonably good performance with simplicity of control and a moderate price, the manufacturers have cut down the "variables" to the smallest possible number; it may, in fact, be said that one quite understandable aim of most set makers is to keep down the number of knobs to as near three as they can possibly manage. The compromises called for by a small number of controls mean necessarily that, however well suited the set is for its own special job, it is not adaptable for others.

To the long-distance man the "broadcast" receiver has many shortcomings. The sensitivity is inadequate, and the simplicity of its tuning arrangements makes them far too coarse for his purpose, at any rate on the short-wave range. On this

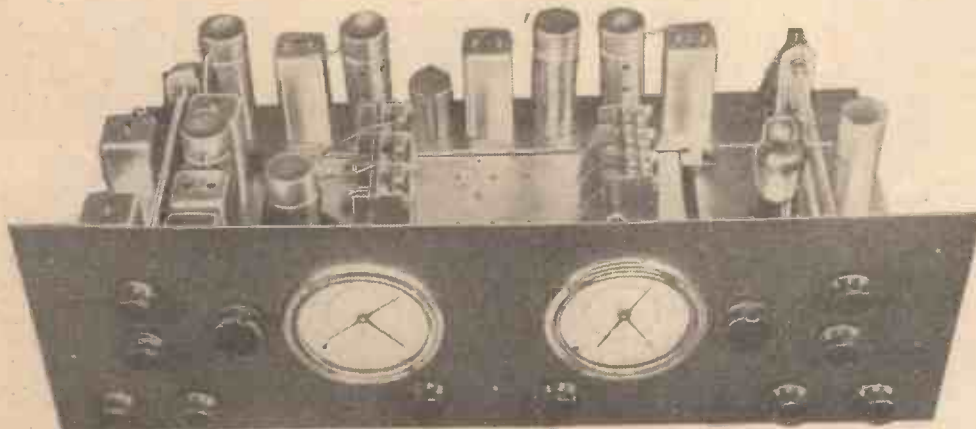

On short wavelengths, bandsread tuning as used in "The Wireless World" communication receiver shown here, is essential for real long-distance work.

Wanted—A New Kind of Receiver

range the dial is often so coarsely graduated, and the pointer so stout, that accurate calibration is all but impossible; nor is the business made easier if the oscillator creeps. Also, the selectivity in this part of the tuning range is frequently inadequate, and second channels are a nuisance, while the waveband coverage is too limited as few of these receivers will tune below 16 metres or above 50.

The only present alternative to the "broadcast" set is the communication receiver, and here we have a beautiful instrument. In a high-class set of this kind there may be a dozen or more controls, each of which is a genuine help to reception. With such a set one can squeeze the last ounce out of any signal, but there is one big drawback, a drawback that is insuperable to many of us, namely, its cost, which may be from £40 to £75, or even more than that.

Planning the Set

Now, after using many communication receivers I have come to the conclusion that most of them are a good deal more elaborate than they need be for our purposes. This kind of receiver is, after all, really a professional's set. For our amateur DX work we could do with something smaller, less elaborate—and less costly. The set that I have in mind is a kind of "sports model" receiver. For want of a better name I call it a "reach-out" set. It would be something betwixt and between the "broadcast" set and the communication receiver. In my view it would be the ideal second set in any family which counts one or more long-distance enthusiasts amongst its members.

What we want for the reception of distant stations is a set that is much more

used have generally been on the lines of the block circuit diagram in Fig. 1, the panel fittings being: (1) Main tuning knob and dial; (2) band spread tuning knob and dial; (3) HF gain control; (4) IF selectivity control; (5) AF gain control; (6) crystal gate on-off switch; (7) crystal balancer; (8) BFO switch; (9) BFO pitch control; (10) tone control; (11) send-receive switch; (12) AVC in-out switch; (13) tuning meter; (14) 'phone jack; (15) mains switch.

These big sets have usually more gain in reserve than one can ever possibly use. The RF gain control is usually kept full on when AVC is in, but I have noticed that if the AF control dial is graduated from 0 to 10 I seldom advance it beyond 2 or 3, and never above 5. Probably we must keep two SF stages in order to get rid of second channels on the short waves. But I think that a single IF stage would suffice—certainly it would if it were regenerative, on the lines described recently by Mr. McMurdo Silver in *The Wireless World*.

The crystal gate is a luxury that can be dispensed with in the interests of economy, particularly as by far the greatest number of long-distance folk go in mainly for the reception of telephony. For the same reasons we can part with the BFO without many sighs. It has its uses when searching for weak telephony signals, but my experience is that it is so seldom brought into action that it will not be greatly missed. One high-efficiency AF pentode following a detector of the

class tuning system is the greatest of aids to success on the short waves. Such systems are expensive, which is one of the chief reasons why I don't want to see cheap reach-out receivers.

Band-spreading—real band-spreading—is essential. By far the handiest and most satisfactory system that I have used consists of a small ganged variable condenser whose sections are in parallel with those of the tank condenser. The tank should have large, finely graduated scales, marked in kilocycles or megacycles, as the case may be. It should have a two-speed drive, as it is a great convenience to be able to return quickly to zero when you have finished exploring one waveband

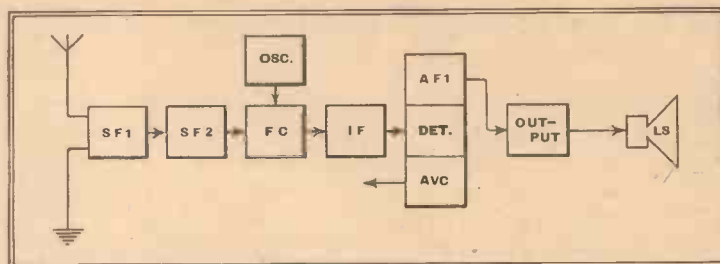

Fig. 2.—Circuit of suggested "reach-out" receiver.

and are about to start on another. The bandsread dial should be as large as that of the tank, but marked simply into 100 equal divisions. The drive here should also be two-speed to facilitate returning to zero. The main dial should read correctly when the small condenser's vanes are fully meshed—that is, with its dial reading 100.

With such an arrangement calibration is simplicity itself. When dealing with, say, the 15 Mc/s band, the main dial is set initially at 15.4 Mc/s, and the bandsread at 100. The log would then read something like this:—

Station	Main	Bandsread
DJR	15.4	87
W2XAD	"	86
OZH2	"	85
GSP	"	84

and so on. To return to any desired station—say, W8XK, logged at 73 on the bandsread dial—it is only necessary to check the settings on one strong and reliable station (GSP would do well). Put the main dial as near 15.4 Mc/s as you can, and set the bandsread dial at 84. Then move the main dial slightly until GSP is tuned in. W8XK, if working, will then be found when the bandsread dial is turned to 73.

Eliminating Non-Essentials

Of the other controls we must certainly keep selectivity, AF gain, AVC in-out, and tone. The last is of great importance, though not all communication receivers—even the biggest of them—have it. Weak signals from great distances are liable to suffer considerably from attenuation of the upper audio frequencies, so much so that, though there is amplification enough available to bring them up to reasonable strength, speech may almost, if not en-

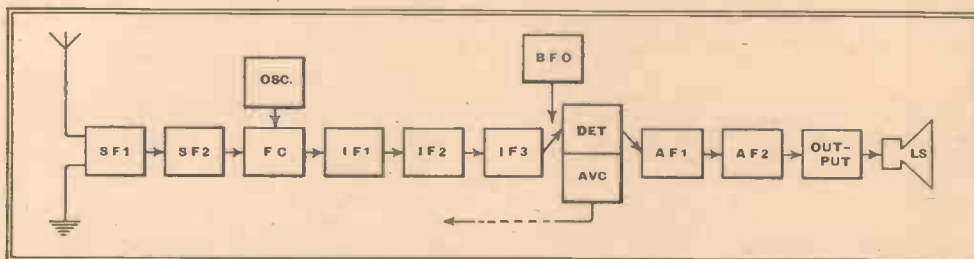

Fig. 1.—Typical circuit arrangement of a communication receiver.

flexible than the domestic one. There must be a considerable reserve of amplification in hand for use when needed; the selectivity must be variable to enable us to get the best out of any signal; the short-wave ranges—I use the plural advisedly—must be highly efficient; and, above all, the tuning must be fine, and so arranged that the set lends itself readily to calibration. How can we meet these needs with a simplified form of communication receiver at a suitable price? And, first of all, what is that price to be? I should put it at about £20. The last thing that I want to see is a cheap reach-out set. We need a precision instrument, and precision does not go hand in hand with cheapness.

Big communication receivers that I have

6B8 type should provide all the AF gain needed.

The circuit is thus cut down to the seven working valves seen in Fig. 2, with, of course, a rectifier in addition. The separate oscillator we must keep, for creeping is one of the things that we specially want to avoid.

Now for the controls, of which the one governing tuning is, to my mind, the most important part of any long-distance receiver. I would far rather have a four- or five-valve set of no great sensitivity, but with good tuning arrangements, than one with cramped, coarsely marked scales and backlash in the condenser drive, no matter how many valves it contained. I am sure that you will agree that a first-

Wanted—A New Kind of Receiver

tirely, be unintelligible when there is no tone control. This should take the form of a bass attenuator with, if possible, a treble boost.

The main switch is obviously a necessity, and the tuning meter also is indispensable. RF gain control I would like to have, and the send-receive switch, too. The latter is most useful even to non-transmitters; it is very handy, for instance, when radiated interference from a passing car's ignition system is a nuisance. But, if need be, these could be sacrificed for economy's sake. The 'phone jack is not really important.

The last point to be considered is the wavelength, or frequency coverage. The set need not take in the long-waveband; for there is nothing of DX interest on it. It should, I think, give continuous coverage from about 9.25 to 550 metres—say, 32.5 Mc/s to 540 kc/s. Allowing for the necessary overlap, this works out very nicely, for a ratio of slightly over 2:1, into six wave ranges. In round figures, and excluding the overlaps, these are as follows:—

32.5	16 Mc/s
16	8 Mc/s
8	4 Mc/s
4	2 Mc/s
2000	1000 kc/s
1000	500 kc/s

The reach-out receiver therefore emerges as a seven-valve set, with genuine band-spread tuning and such desirable controls as selectivity, AF gain, AVC in-out, and tone. If our price limits will run to them there will also be a RF gain control and a send-receive switch.

Such a set, if well designed, should be immune from such things as oscillator drift and second-channel interference. There should be sufficient gain at hand for all amateur DX purposes, and selectivity variable between, say, 2 kc/s and 12 kc/s should enable us to get the utmost out of any signal. The suggested tuning arrangements would certainly be a joy to use.

That is the kind of set that I should like to have. But one man's meat is proverbially another man's poison, so your ideas may differ from mine. If they do, remember that the correspondence columns of *The Wireless World* are always open to your suggestions. Between us we may evolve and induce the manufacturers to give us the perfect £20 long-distance receiver.

Television Programmes

Sound 41.5 Mc/s. Vision 45 Mc/s.

An hour's special film transmission intended for demonstration purposes will be given from 11 a.m. to 12 noon each weekday. The National or Regional programme will be relayed on 41.5 Mc/s from approximately 7.45 till 9 p.m. daily.

THURSDAY, JUNE 29th.

3, "An Expert in Crime," a play by S. E. Reynolds and Frederick Carlton. 3.35, British Movietonews. 3.45, 255th edition of Picture Page.

9, Walsh and Barker in Cabaret. 9.35, Gaumont-British News. 9.45-10.15, 256th edition of Picture Page.

FRIDAY, JUNE 30th.

3-4.30, "Smoky Cell," a play by Edgar Wallace.

9, Beatrice Lillie—Starlight. 9.15, British Movietonews. 9.25, Tennis Demonstration by Dan Maskell. 9.40, Cartoon Film. 9.45, "Nancy's Puppets" in "Pyramus and Thisbe." 10, Film. 10.10-10.40, "The Words Upon the Window Pane," a play by W. Butler Yeats.

SATURDAY, JULY 1st.

3, Jerome Kern Programme by Eric Wild and his Band, with songs by Kay Kimber. 3.20, Charles Heslop in "Percy Ponsonby Goes to Wimbledon." 3.30-4.30, O.B. from the Centre Court at Wimbledon of the Tennis Championship Meeting. Commentary by T. Woodroffe.

9, Wyn Richmond in songs, with Evel Burns at the piano. 9.10, "Cricket on the Green"—E. H. Tattersall. 9.15, Gaumont-British News. 9.25, "Fiat Justitia." Excerpts from famous trials of literature and drama. Cast includes D.A. Clarke-Smith and Charles Heslop. 10.15, Cartoon Film. 10.20-10.30, Eleanor Warren, cello.

SUNDAY, JULY 2nd.

3.25-4.30, A.R.P. Parade, Hyde Park, in the presence of His Majesty The King. O.B. of the first massed parade of A.R.P. units in London.

8.50, News. 9.5, Sir Ronald Storrs, Speaking Personally—"American Impressions." 9.15, The Covent Garden Ballet in "Les Sylphides." 9.50, British Movietonews. 10-10.30, Ruth Draper, the famous American diseuse.

MONDAY, JULY 3rd.

3, Scenes from Henry Sherek's "Dorchester Floor Show." 3.20, British Movietonews. 3.30-4.0, Tennis O.B. from Wimbledon.

9-10.30, Leon M. Lion and Louise Hampton in "The Silver Box," by John Galsworthy.

TUESDAY, JULY 4th.

3, "In Search of Valour," a comedy by Teresa Deevy. 3.30-4, Tennis O.B. from Wimbledon.

9, Elizabeth French and Bruce Carfax in Songs from "Bitter-Sweet" and "White Horse Inn." 9.10, "American Art To-day"—talk. 9.30, British Movietonews. 9.40-10.40, "Whistling Bullets"—Western Film.

WEDNESDAY, JULY 5th.

3, "Down on the Farm," O.B. from Bull's Cross Farm, where A. G. Street and the Farmer will discuss work for July. 3.15, Fashion Parade. 3.30-4, Tennis O.B. from Wimbledon.

9.5, Gaumont-British News. 9.15-10.30, "Luck of the Devil," a comedy by Lynton Hudson.

Five-metre DX

RECEPTION ON THE EAST COAST

SINCE June 10th last, conditions have not favoured long distance reception on 56 Mc/s, and for all practical purposes this band has been useful only for local communication.

Some notes regarding reception during the whole of May and the first three weeks of June have been received from G6DH in Clacton-on-Sea, Essex. Of 21 stations heard or worked 17 were over 50 miles away and these comprise G2AO (85), 2HG (54), 2LW (58) 2MR (67), 2MV (62), 2XC (120), 2XG (50), 2ZV (110), 5BY (60), 5MA (70), 5TX (130), 6CW (125), 6FO (175), 6OH (70), 6OT (54), 6QZ (58), and 8SK (52).

The figures in parentheses are the approximate distances in miles from G6DH.

A French station was heard on June 9th at 9.50 p.m. and another at 8 a.m. on the 13th of the month, but telephony was employed and they could not be identified, owing to bad fading.

Should these notes be seen by our continental confrères, may we make a plea for signing off on CW for identification? G6DH comments on the fact that many of the stations he received at good strength fail to reply to his calls, and ventures to suggest that the average five-metre transmitter is now far more efficient than the accompanying receiver, while better aeriols, such as beam arrays, might be used with advantage. We, too, have had similar experiences and deplore the fact that so many insensitive receivers are still in use on this band.

In due fairness to all, however, it should be stated that even when equipped with a sensitive superhet, local interference at times can be so bad that even moderately strong CW signals are almost unreadable. The great bugbear on five metres is unquestionably motor-car ignition noise.

G2MC.

HOME RECORDER

Designed for operation with a standard broadcast receiver, this home recorder has recently been produced in Holland by Philips. Coated glass blanks are normally used, while the driving motor, which exerts a torque of some 10,000 g/cm., is flexibly mounted and coupled to prevent the transmission of vibration to the turntable.

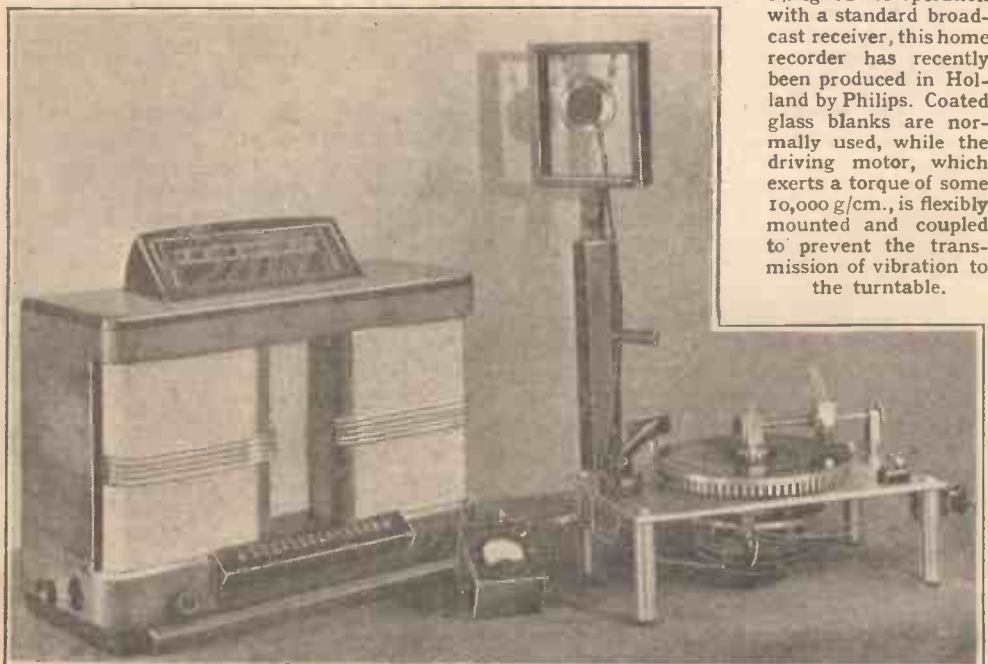



UNBIASED

BY
FREE GRID

You can knock the aerial over.

A Leakage of Information

I WAS greatly dismayed to read in the *Wireless World* the other day of a new type of aerial which has been evolved to overcome certain difficulties associated with car radio, the reason for my dismay being that a similar invention of my own has been literally "beaten on the post."

The trouble with car aerials has always been to find a compromise between wireless efficiency and the limitations imposed by the necessity that the aerial should be in a position where it is not liable to damage. It has long been known that one of the most suitable arrangements from a purely wireless point of view is a simple vertical rod mounted on the roof. Unfortunately, such a position has in the past been almost entirely ruled out by the fact that the aerial rod gets smashed up if the car passes under a low arch, or even by some careless person putting baggage on the roof, although I am told that in the best circles they do not do that nowadays. It must, however, be remembered that being an ardent wireless man I do not confine myself to the best circles but associate impartially with everybody, including the wireless manufacturer in his humble cottage and his customers in their stately mansions.

Now, as some of you may know, in some foreign countries they do not employ the brutal methods of our own police of hitting you over the head with a wooden truncheon if you are obstreperous on your way to the station. Out of consideration for the prisoner's skin they use a rubber truncheon which, like a stocking filled with sand, stuns but leaves no mark.

A certain foreign police force recently placed an order with an English manufacturer for a few gross of these articles but refused to accept delivery owing to their being rather too hard and therefore liable to hurt the prisoners. Mrs. Free Grid, with a woman's inability to resist buying anything which is "marked down," irrespective of whether she has a use for it or not, bought several packing cases full of these truncheon throw-outs very cheaply, with the result that I was absolutely compelled to invent something in which they could be used.

I have always been fired by reading tales of how great inventions came into existence, one of my favourites being the story of how James Watt invented the steam engine as a means of using up the surplus steam from his mother's kettle after an occasion on which he had been

scalded and scolded through forgetting to take it off the gas ring in time, and so allowing it to boil over. You will understand, therefore, that the little matter of inventing something to use up the surplus rubber truncheons did not worry me greatly, and I soon conceived the idea of boring a hole down the centre and inserting a flexible wire, the whole gadget being then mounted on a car roof to act as an aerial. The beauty of the idea is that you can knock the aerial over by driving the car under a low bridge, or even by throwing a heavy trunk on it, but afterwards it will, by virtue of its resiliency, spring into its correct vertical position once more.

Now that I have been forestalled, of course, I have several gross of useless rubber-truncheon car aerials on my hands, for to use them now would be against my principles. It seems to be a remarkable coincidence that two minds should simultaneously think of this great idea, and even though the inventor is not using actual rubber truncheons, I can't help thinking that there has been a leakage of information in my household. Can any of you budding Hornleighs see any vital clue that I may have overlooked?

Advice to Manufacturers

ALTHOUGH it seems hardly possible to realise it, Radiolympia is only two months ahead and I have been giving thought to the question of what manufacturers are going to offer us in the way of new sets this year, and I am taking this opportunity of giving one or two well-meant criticisms in advance. The reason for this is that, although from what I hear there are some good things in store for us, certain set makers are in one or two respects following the example of the late Mrs. Bloomer in their manufacturing efforts, and if I make my criticisms now there is still time for them to repair these bloomers before the Show starts.

There is, I hear, a considerable number of new television sets being got ready for us, this being to my mind a strong indication that we shall soon have a provincial television service, as I know wireless manufacturers too well to believe that they would risk their money in this way unless they knew something. Talking of television, I hear on reliable authority that combined radiograms and television sets are not altogether popular. This is not because, as you might think, the tele-

vision part of them is liable to become obsolete more quickly than the other part; the boot is on the other foot nowadays, as television design has settled down so firmly that it is the "ordinary" half of a combined instrument that is liable to get out of date first.

Combined radiograms and television receivers have, by no means, disappeared from the market, however, and there is one very strong criticism about them which I desire to make and that is that without exception they are all AC driven. I am quite aware that the only way for DC users to have television in their houses is for them to employ a rotary converter, but why compel them to use a converter for driving the ordinary wireless and gramophone part of the outfit too? Television is only on for a short time each day, and nobody wants a converter running to operate an ordinary set all day. What is the matter with marketing a few of these instruments with only the television part AC driven, so that DC users could switch the converter off in non-television hours? It is all very well to say that DC users should buy their television sets and radiograms separately; why on earth should they?

There is yet another point of criticism about the sets which I learn will be inflicted on us this year, and that is this remote control business. Personally, I am all in favour of remote control, and shall

Put it under the floorboards.

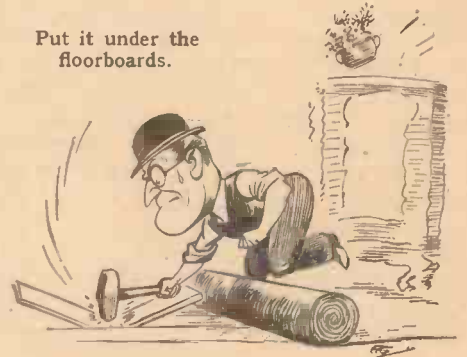

welcome the opportunity of having all the buttons in a neat little unit on the arm of my chair, but why on earth is there no provision for taking the unit into another room and connecting it to the end of an extension wire there? Practically every set is provided with terminals for operating an extension loud speaker in another room, and while running the flex to the loud speaker there it is no more trouble to run extra wires for the push-buttons; in fact, there is a splendid opportunity for someone to market a multi-core extension cable, including loud-speaker wires as well.

I do realise, of course, that multi-core cable is liable to be somewhat fatter than a loud-speaker flex, but so much the better, as it is less liable to get kinks in it and, in any case, it is perfectly easy to put it under the floorboards.

Recording on Steel Tape

EQUIPMENT FOR REPRODUCING DICTATION AND TELEPHONE CONVERSATIONS

A METHOD of magnetic recording was introduced by Poulsen in 1900, and was used in conjunction with his arc system of radiotelegraphy. It was known as a "Telegraphone." Telegraph signals transmitted at high hand speed were recorded at the receiving station on a steel wire, i.e., circular cross section, driven at a higher velocity when recording than during reproduction. Thus the signals could be transcribed at a convenient speed for the operator. In the same year Poulsen obtained a U.S. Patent No. 661,619 for steel tape as a recording carrier or medium.

Although Poulsen proved the possibilities of magnetic recording, the development of a practical "quality" system had to await the coming of thermionic valve amplifiers. Research into the metallurgical problems of the special steel tape required was commenced by a German engineer, Dr. Stille, in 1924; this, together with his work on the mechanical and electro-magnetic questions involved in this system, was of great importance. The Blattnerphone, which was first employed by the B.B.C. some years ago, was largely based on research and patents due to Dr. Stille, although certain improvements were made by B.B.C. engineers in collaboration with the British Blattnerphone Co. In 1933 Marconi's Wireless Telegraph Company designed a machine in which certain defects in the original model were overcome, and this instrument, known as the Marconi-Stille recorder, is used to-day by the B.B.C. and other organisations.

The process of magnetic recording depends basically upon two properties of steel, namely, remanence (i.e., the

length of steel to be magnetised, to a great extent independently. In its simplest form magnetic recording can be carried out by pulling a length of steel wire or tape at constant velocity through a recording head which will vary the distribution of remanent flux along the length of the wire. Reproduction can be obtained by passing the magnetised tape at the same velocity through a reproducing head which is sensitive to the tape's flux changes.

It is essential that any previous variations in the flux distribution in the tape should be removed before recording. This is usually done by drawing it through a "wiping" or "wash-out" head which magnetises it to saturation. To obtain optimum results it is also necessary to bring the magnetic condition of the tape at the instant of magnetisation to such a point on the hysteresis (B-H) curve that the remanent magnetisation corresponds to the waveform of the current through the winding. This is performed by a biasing or polarising current. The wiping, recording and reproducing heads usually have different types of coils and pole-pieces, but are otherwise identical. The steel tape may be magnetised longitudinally, or transversely, through its thickness or through its width, or in any combination of these directions.

IT is well known that the B.B.C. has been recording programmes on steel tape for many years past, and the actual equipment has been exhibited at Radiolympia. A combined recording and reproducing instrument of this type for use in offices can now be obtained, and is described in this article. Various refinements have been added, the most important being provision for direct connection to the G.P.O. telephone circuit for recording conversations without the intervention of a microphone or of the G.P.O. telephone earpiece.

and, thirdly, the recording impressed upon the sound-carrier can be easily obliterated, thus leaving the tape free for further recordings.

A steel wire magnetic recorder suitable for use in offices has now made its appearance under the name of Textophone. It is housed in a cabinet of similar size to an average radiogram, and provides an uninterrupted recording of 20 minutes' duration. The sound input can be either from microphone or by direct connection to the telephone circuit, for which the G.P.O. has granted permission.

Two pairs of coils are arranged in the recording-head. Each individual coil is provided with a guide slot for the core pressing against the steel wire under spring pressure. The pair of coils first influencing the wire are fed with DC, which erases any previous recording. The second pair are also fed with DC for magnetic biasing purposes, but there is a superimposed alternating current representing the sounds to be recorded. For reproduction the wire moves in the same direction as when recording. A single ear-piece and also a pair of headphones are provided.

The steel wire is stored on interchangeable drums, and is run to and fro through the recording and reproducing mechanism by an electric motor. The speed of the moving wire as it passes from one coil to the other is approximately 5 feet per second, this speed being kept as constant as possible by using a synchronous driving motor.

Valve amplification is, of course, used, and the various switching operations are remotely controlled by push-buttons and telephone-type relays. Thus the master Textophone unit can be situated anywhere in a building, with small control panels at each operating position. Circular scales with markings in minutes are fitted which show the time available for a recording. About 2 minutes before the end of a spool of wire is reached a strong buzzer signal is heard in the headphones.

Two features of the Textophone of outstanding interest are that a second recording on the wire automatically obliterates a previous one, irrespective of whether the erase key is operated or not, and that

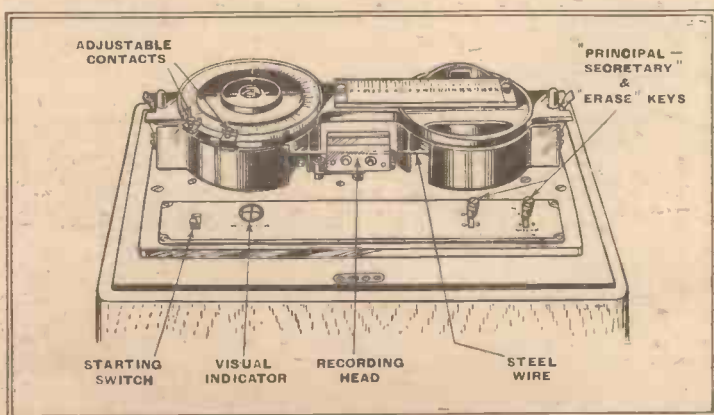

amount of magnetic flux remaining in a path, which has been magnetised, after the impressed magneto-motive force has been removed) and coercivity. This latter property permits adjacent elements in a

The distinguishing characteristics of magnetic recording are, first, that immediate play-back is possible as no processing is required; secondly, it is unaffected by external vibrations or mechanical shocks;

Recording on Steel Tape—

each time the stop key is pressed the tape runs back a little before finally stopping. The object of this latter arrangement is to permit the last few words of the previous message to be repeated when a new one is started. The overall frequency response of the instrument is said to be 100 to 8,000 c/s.

The purchase price of a complete Textophone equipment with one spare spool of wire is £198 10s. net, but rental or graduated payments are permissible. It is obtainable from E. Shipton and Co., Ltd., of 24, Broadway, London, S.W.1.

D. W. A.

Premier Transmitting Racks

THE rack-form construction of amateur transmitters and modulating equipment combines the advantages of attractiveness and flexibility, for by assembling the various stages on separate chassis any one part can be replaced by a different circuit without disturbing the remainder of the equipment or detracting from its frontal appearance.

The racks, designed by the Premier Radio Co., Jubilee Works, 167, Lower Clapton Road, London, E.5, are fitted with panels 19in. wide, which is the standard size now employed in racks of this kind.

Our illustration shows a three-tier rack measuring 39in. high and 19½in. wide overall. Each chassis is 17½in. wide and 12in. deep (back to front), and has 2in. side-pieces. There are three panels measuring 19in. x 10½in., and a smaller one 3½in. wide at the top for meters.

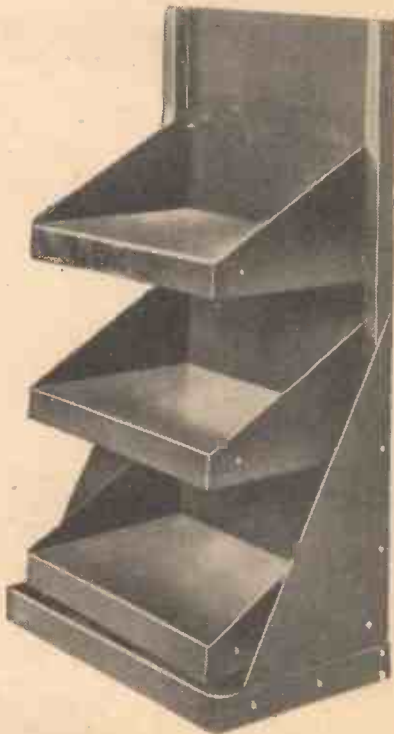

Three-tier transmitting rack made by Premier.

Finished in black crackle enamel, this rack cost £2 14s. complete, but the parts can be purchased separately if desired. The main framework costs £1 2s. 6d., chassis with brackets 5s. 6d. each, and 19in. x 10½in. panels 4s. 6d. each. The price of the small meter panel is 1s. 6d. Thus it costs no more to buy the parts separately and as required than it would to purchase a complete rack.

In Forthcoming Issues

MAGNETIC TELEVISION RECEIVER.
Full details for home construction.

SHORT-WAVE ADJUSTMENTS.
Trimming the SW circuits of an all-wave superhet.

POWER SUPPLY UNIT. For generating HT for a portable transmitter; a vibratory converter, operated from a 6-volt accumulator, is employed.

For those who require a larger rack there is a six-tier one which measures 67in. high. Complete, it costs £4 10s. The framework only costs £1 10s., and it accommodates the same chassis and panels as the 39in. size. There are available also panels 7in. wide which fit both racks, and these cost 3s. each.

HENRY FARRAD'S SOLUTION

(See page 604)

AS the explanation of the previous trouble, based on the assumption that the IF of the set is about 470 kc/s, is correct, it may be assumed that the IF is as stated. The information in the present letter also leads to this conclusion, because Milan is on 814 kc/s, and London Regional on 877. The second harmonic of London Regional is, of course, 1,754 kc/s, and for this to come in on the second channel when tuned to Milan the IF must be half the difference

$$\text{i.e., } \frac{1754-814}{2}, \text{ or } 470.$$

Now Brussels No. 2 is on 932 kc/s: half this is 466. Radio-Lyons is 1393: one-third of this is 464. The other stations affected give figures in the same neighbourhood. The whistles are therefore probably due to harmonics of the IF. Harmonics are inevitably produced by the rectification of the IF by the diodes, and unless proper precautions are taken these are liable to be picked up by the aerial or circuits near the input, beating audibly with any station tuned in which is nearly equal in frequency. This is especially liable when, as in this case, there is no audio stage and consequently a considerable IF voltage at the diodes, and a radio stage to amplify any harmonic leakage. Even when the frequency of the station being received differs from an IF harmonic frequency by more than an audible amount, the actual IF is altered by a slight mistuning, and the whistle is heard, as Mr. Keen noticed.

The usual precautions to avoid this trouble are careful screening of the diode circuits and a filter between them and the pentode section of the valve. If one of the condensers in this filter became open-circuited, or the screening unearthed, harmonics would almost certainly cause trouble, so Mr. Keen is advised to examine this part of the set.

PROBLEM CORNER No. 25

A Correction.

IT is feared that the task of would-be solvers of Henry Farrad's problem last week was made more difficult by an error in the circuit diagram of Philip Cowe's receiver. The short-circuiting switch for the long-wave reaction coil should be joined directly across the coil and not to earth; in the position shown it would impose a partial short-circuit across the HT supply. In order that reaction may be effective on long waves, this switch must, of course, work in opposite sense to the others.

News from the Clubs**General Experimental Wireless Club**

Headquarters: Barnard Castle School, Barnard Castle, Co. Durham.

Hon. Sec.: Mr. D. Knox, Barnard Castle School, Barnard Castle, Co. Durham.

This club, which is additional to those given in the directory of clubs published in our April 6th issue, has now been in existence for five months, and the members are desirous of getting into touch with other organisations.

Ashton-under-Lyne and District Amateur Radio Society

Headquarters: Commercial Hotel, 80, Old Street, Ashton-under-Lyne, Lancs.

Meetings: Alternate Wednesdays.

Hon. Sec.: Mr. K. Gooding, 7, Broadbent Avenue, Ashton-under-Lyne, Lancs.

A new club room has been obtained, and it is hoped to install gear shortly, and to apply for a transmitting licence.

Dollis Hill Radio Communication Society

Headquarters: Braintcroft School, Warren Road, London, N.W.2.

Meetings: Wednesdays at 9 p.m.

Hon. Sec.: Mr. E. Eldridge, 79, Oxgate Gardens, Cricklewood, London, N.W.2.

Ordinary meetings have been cancelled until September.

Romford and District Amateur Radio Society

Headquarters: Y.M.C.A., Red Triangle Club, North Street, Romford, Essex.

Hon. Sec.: Mr. R. C. E. Beardow, 3, Geneva Gardens, Chadwell Heath, Essex.

On May 14th a joint field day organised by the Southend Society was held. On June 11th a second field day organised by the Romford Society took place, at which there were 39 entries contained in 12 cars and one bicycle.

The Society's transmitter, G4KF, has been licensed for portable operation. At a recent meeting a representative of Peto-Scott demonstrated a "Trophy" receiver.

Southend and District Radio and Scientific Society

Headquarters: Strand Chambers, High Street, Southend-on-Sea, Essex.

Meetings: Alternate Fridays at 8.15 p.m.

Hon. Sec.: Mr. J. M. S. Watson, 23, Eastwood Boulevard, Westcliff-on-Sea, Essex.

The following programme of field days has been arranged for the summer months:—

July 3rd.—56 Mc/s Field Day.

August 21st.—1.7 Mc/s DF Field Day.

September 24th and 25th.—All night 1.7 Mc/s DF Test.

October 23rd.—1.7 Mc/s DF Field Day.

British Sound Recording Association

Headquarters: 44, Valley Road, Shortlands, Kent.

Hon. Sec.: Mr. F. J. Chinn, 14, Tirlmont Road, South Croydon, Surrey.

On June 9th a members' equipment evening was held at the London meeting room off the Strand. For this meeting each visitor contributed an item of equipment which he described and demonstrated. Mr. D. Davidson brought along a recording and play-back amplifier, and also a moving coil microphone. Mr. L. Widger, research engineer of the National Institute for the Blind and St. Dunstons, provided two portable reproducers, one electric and the other an acoustic model with stethoscope earpieces, for playing the 24 r.p.m. "talking books for the blind." A ribbon microphone was demonstrated by Mr. C. Appley, while Mr. D. Allous provided a special Presto recording of an American sponsored programme. Mr. D. Roe contributed a ribbon-condenser microphone, some novel tracking mechanisms being shown by Mr. J. Hale.

Eastbourne and District Radio Society

Headquarters: The Science Room, Cavendish Senior School, Eastbourne, Sussex.

Hon. Sec.: Mr. T. G. R. Dowsett, 48, Grove Road, Eastbourne, Sussex.

At the last meeting Mr. A. Achurch gave a lecture entitled "Television Transmission and Reception." He dealt with the subject in a very thorough manner, commencing with a very detailed account of the work of the pioneers.

Edgware Short Wave Society

Headquarters: Constitutional Club, Edgware, Middlesex.

Meetings: Wednesdays at 8 p.m.

Hon. Sec.: Mr. F. Bell, 118, Colin Crescent, Hendon, London, N.W.9.

Arrangements are well in hand for the society's five-metre field day to be held on July 2nd. There are ten entries. The transmitter, which will be in charge of G2QYP, will radiate each hour for five minutes. The station is also working in the RSGB field day on July 9th.

Among future activities will be a lecture by a Voigt representative, a discussion on practice and theory and a discussion on five-metre field day apparatus.

Watford and District Radio and Television Society

Headquarters: Carlton Tea Rooms, 77, Queens Road, Watford, Herts.

Hon. Sec.: Mr. P. G. Spencer, 11, Nightingale Road, Bushey, Herts.

A successful junk sale was held on May 18th.

Microphones at Alexandra Palace

DETAILS OF THE E.M.I. MOVING COIL AND RIBBON TYPES

FROM the very first the quality of the sound accompaniment to television has set a standard which is rarely equalled in the course of the daily programmes on medium and long waves, and there has been much speculation as to the origins of this advance in the technique of collecting and converting sound.

A recent paper read before the Wireless Section of the Institution of Electrical



Front view of E.M.I. moving-coil microphone. It is built to withstand the hard use to which it is put in the shifting scenes of the television studio.

Engineers' and the subsequent discussion have gone a long way to clearing up the mystery, and it is now fairly certain that the good results may be attributed to (a) the use of amplifiers of improved electrical characteristics, particularly as regards low harmonic distortion; (b) fortuitous studio characteristics and new arrangements of microphone placing, resulting from the necessity of keeping the microphone out of the field of vision of the cameras; (c) the advantage which has been taken of an ultra-high frequency carrier to extend the range of modulation frequencies up to and well beyond 10,000 c/s. This is roughly the order of importance of the factors affecting quality.

It goes without saying that the microphones, which are the prime movers in any broadcasting system, must be of the highest possible quality. Those used at Alexandra Palace have been developed by Electric and Musical Industries, Ltd., and are of both the ribbon and moving coil types.

The moving coil microphones, which are a development of the type which has already won its spurs in the production of electrical gramophone recordings, are robust and are the ones generally used when the scene calls for continual movement of both microphone and camera. Amplifier channels are provided for three ribbon and five moving-coil microphones.

The diaphragm of the moving-coil microphone is a disc of balsa wood about 2½ mm. thick enclosed between thin aluminium sheets, one of which is used as an annular surround. This is stretched under radial tension by the ring B to obviate minor instabilities and also as a means of adjusting the resonant frequency.

The stretching ring is arranged to shield the thin surround from direct sound waves, and parasitic resonances in the surround are controlled by a groove C cut in the inner surface of the ring, in conjunction with air viscosity in the small clearance between ring and diaphragm.

The diaphragm weighs only 0.75 gram, and its resonant frequency in conjunction with the restoring force of the stretched diaphragm is relatively high. In order that it shall not be still further raised by the air volume enclosed behind the dia-

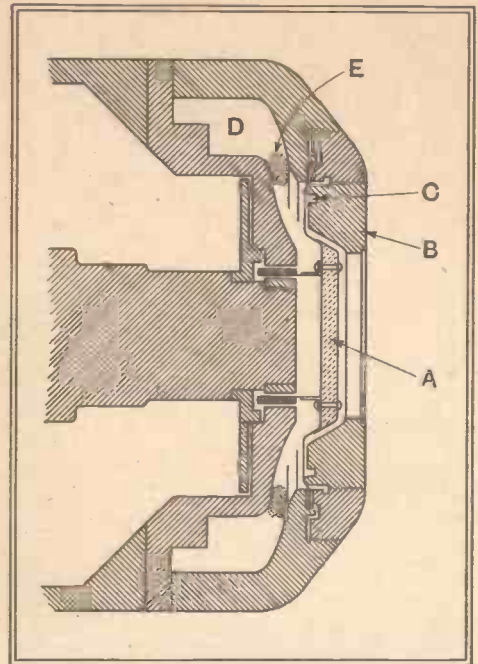

Cross-section of diaphragm assembly in the E.M.I. moving-coil microphone

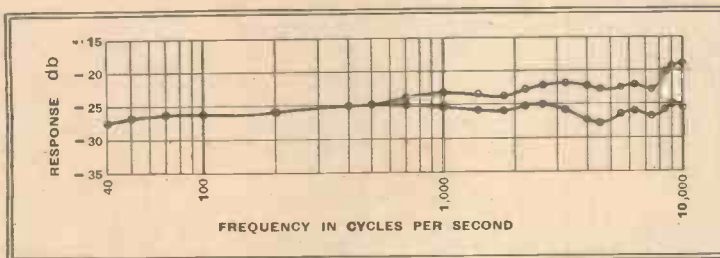

Frequency response of moving-coil microphone with its "A" amplifier. The vertical scale represents the electrical power level minus the acoustic power level. Zero db. on the electrical scale is 1 milliwatt and on the acoustic scale is (1 dyne/cm²)². The upper curve is for a sound source on the axis and the lower for random sound.

phragm an enlarged air cavity D is provided with a cotton wool ring E at the mouth to prevent "Helmholtz resonator" effects.

Enamelled aluminium wire is used for the moving coil and is wound on a thin aluminium former which is riveted to the balsa wood diaphragm. The energised magnet system is of the conventional "pot" type and is constructed of cobalt

A stretched plane ribbon is employed in the E.M.I. ribbon microphone. It is coupled to the amplifier through a transformer with a stranded-wire primary.



iron. Recently a permanent magnet version has been introduced.

Mechanical resonance of the diaphragm system is controlled by electromagnetic damping. A series circuit, resonant at the same frequency as the fundamental of the diaphragm system, is connected across the output. At resonance the impedance of this circuit is low and acts as a shunt preventing the development of the increased amplitudes which would otherwise be associated with the mechanical resonance. In order that the correction may be exact, not only in magnitude but in phase, the ratio of L, C and R is adjusted to equal that of the mechanical mass, compliance and damping.

A three-winding step-up transformer is used between the microphone and the grid of the first valve in the microphone amplifier, and the equaliser circuit is connected across the third winding. There are two additions to the simple series resonant circuit: (1) the inductance is shunted by a condenser and resistance to

¹ The Marconi-E.M.I. Audio-Frequency Equipment at the London Television Station, by I. L. Turnbull, M.Sc. (Eng.) and H. A. M. Clark, B.Sc. (Eng.).

Microphones at Alexandra Palace—
compensate for the increase of microphone
impedance at high frequencies and (2)

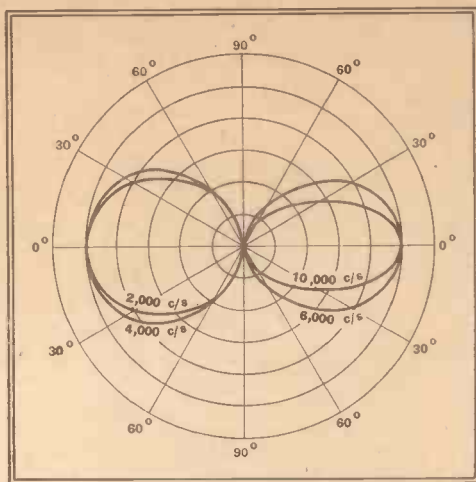

Vertical polar diagram of the E.M.I. ribbon
microphone.

the condenser is shunted by a resistance to reduce the output below 50 c/s and thus to attenuate heavy LF transients.

In the ribbon-type velocity microphone a permanent magnet with ventilated pole pieces is employed. The aluminium ribbon is only 1in. long and 0.00005in. thick. It is uncorrugated, and its tension is adjustable by means of nuts on the pillars supporting the ribbon clamps.

The impedance of the ribbon is only 0.25 ohm, and a special shield transformer, the primary of which is wound with 9-strand wire to avoid eddy current losses at high frequencies, is mounted at the base of the magnet.

Directional Response

The directional properties of a ribbon microphone in a horizontal plane are frequently made use of, but the vertical polar diagram which also has a minimum for sound directed towards the end of the ribbon generally shows some frequency distortion due to the wavelength of the higher frequencies being comparable with the length of the ribbon. This was one of the reasons leading to the adoption in the E.M.I. ribbon microphone of a shorter ribbon, for in television the microphone must often be suspended out of sight above the performers' heads, as in film studio technique, and it may not be possible to avoid picking up some of the sound at an acute angle to the ribbon.

It will be seen that the qualities of both moving coil and ribbon types find application in television programmes, and their improved performance is in no sense unworthy of the very high standard which has been achieved elsewhere in the audio-frequency equipment, particularly in the amplifiers.

Frequency response
of the E.M.I. ribbon
microphone (without
amplifier) taken on
the axis.

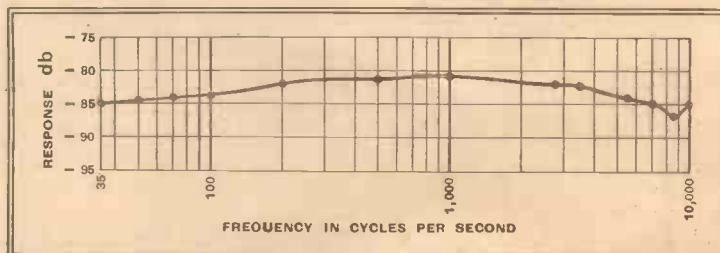

Random Radiations

By "DIALLIST"

Signs of the Times

HAVE you noticed how much more common an object of the town and the countryside the television aerial is becoming these days? I'm referring, of course, to the H-shaped dipole-and-reflector assembly that every viewer seems to use here, though the arrangement is not at present much favoured in the United States. The other evening I drove along a piece of road running through three small country towns and partly through one largish one. When I last took that drive, not long before Christmas, there were two television aerials to be seen; this time I counted seven, and probably I missed one or two, for a good many houses, standing back from the road, are now hidden from view by the dense screening of tall trees in full leaf. It is dangerous to argue from the particular to the general, but if that kind of increase is taking place in other localities we can feel that television is now really catching on.

Who Are the Viewers?

And from what I have seen of other places in the service area of the Alexandra Palace transmitter I'm inclined to believe that that two-to-seven increase is no bad indication of what is happening. In my own little town there was only one television aerial a year ago. A second appeared in the early autumn. Now there are five that I know, and I believe that there are one or two others. To revert to the aerials seen during my recent trip, the distribution of these is rather interesting. One rose proudly over a wireless shop, one adorned an inn, the rest belonged to private houses. And it is noteworthy that of these five private-house aerials two belonged to quite small homes on housing estates. It isn't, then, only the wealthy who are going in for television; viewers are of all sorts and conditions.

The Old Lady Shows Her Pictures

ONE of my friends is an old lady, a widow whose only son has to be abroad during the greater part of the year. She can't get about very much and somebody suggested to her that a television receiver was just what she needed to furnish entertainment in the evenings when she is alone and to keep her in touch with what is going on in the world. At first she shied at the idea, being firmly convinced that she would never be able to work a vision receiver herself. However, she saw one or two and found that they weren't so difficult to operate after all. After some cogitation she had one put into her house on trial. Not many days passed before she decided that it must be a per-

manency, and now it is the joy of her life. So completely at home does she feel with the set that she gives viewing parties whenever any big event is televised and won't allow anyone but herself to touch it. Anyone more completely unmechanically minded than she I can't imagine; that she works her own apparatus with the greatest success is proof enough that the modern vision receiver is a pretty simple thing to operate.

Semi-Scrambling

YOU may remember that I recorded a week or two ago in these notes having tuned in Raymond Gram Swing's weekly talk direct from New York and having found the transmission apparently "semi-scrambled." A Washford reader is kind enough to send me an explanation. He tells me that the "privacy" equipment is never employed when communication channels are used for broadcast relays, one reason for this being that it would cause a deterioration rather than an improvement in the quality. During broadcast relays this equipment is removed and the single-sideband carrier-suppressed system of transmission is brought into operation. My reader suggests that the good quality of the Swing relays is mainly due to this: the system improves the signal-to-noise ratio very considerably and has good effects on the quality by minimising the effects of selective fading.

Must Try This

He tells me that speech was, as I noted, partly intelligible because of the transmission of a "residual carrier," with an amplitude 10-20 decibels below normal level; a carrier very small in comparison with the sideband amplitude is apparently sufficient to make speech transmitted by the single-sideband suppressed-carrier system to some extent understandable when reception takes place in the ordinary manner. "But if," he adds, "you heterodyne these relays with a beat-frequency oscillator, adjusting it to zero beat with the receiver residual carrier, you will find, provided that the amplitude of the injected frequency is adequate, that speech can be received satisfactorily." I must try that next Saturday by using my communication receiver and bringing the BFO into action. Many thanks to my correspondent for this tip and for the information that he has sent.

Why Does Backlash Survive?

ONE of the things that puzzles me about some of the modern wireless sets is that so much backlash should be found in their tuning condenser drives. This doesn't matter enormously on the medium waves or the long, but it is something more than a nuisance when you are using the short-wave range. In the old days we were careful to select dials whose drive didn't suffer from backlash; I can remember turning down certain makes that did so suffer, but it was not too difficult to find others that were satisfactory. I suppose it's this thrice-accursed craze for price-smashing that is responsible for the survival of the backlashy drive to-day. One finds it mostly in the

cheaper sets, though certain of the more expensive ones also harbour it. On the other hand, some of the good sets are blessed with positive condenser drives that are a joy to use. But at this time of day these shouldn't be confined only to certain sets; they should be found in all.

Channel-Sharing

THE description in *The Wireless World* for June 15th of the semi-directional aerial array of the Start Point station was specially interesting because it shows one way in which the provisions of the Montreux Plan regarding certain stations may be carried out. Under previous plans it was assumed that two stations in different countries could share a channel without causing mutual interference if they were separated geographically by 1,000 miles or so. When the present Lucerne Plan came into operation it was very soon found that this was not necessarily the case; Jerusalem's appearance as a background to the North Regional is probably the best-known instance in this country of long-distance mutual interference; but it is by no means the only one. Those who worked out the Montreux Plan have solved the problem—in theory at any rate—by laying down that most of the many pairs of stations to which single channels have been assigned shall reduce their radiation in one another's direction, or radiate mainly towards a particular quarter.

Reducing Mutual Interference

Turku, in Finland, for example, is to be the partner of Tunis on 318.1 metres; Turku is to reduce its sky-wave radiation to the S.S.E. and Tunis its sky-wave radiation to the N.N.W. The same provisions are made about the Latvian Riga and the Libyan Tripoli on 251 metres. Smyrna, it is hoped, will avoid interfering, on 440.5 metres, with Cologne by using an aerial array directed towards the S.W. And so the plan has been worked out to avoid mutual interference by getting some stations to radiate in a particular direction, some to minimise their ground-wave radiation towards certain quarters and some to do likewise with the sky-wave. But, curiously enough, Start Point, whose radiation is directly mainly E. and W., is to share 245.5 metres with the Russian Tchernigor next spring. Tchernigor lies within about 10 degrees of due east from Start Point, the distance between the two being some 1,500 miles. As the Russian station is not shown as using any kind of directional aerial, it won't be surprising if either it or Start Point has eventually to move to another channel.

The Modern Portable

TWO things have served to revive the popularity of the portable wireless set: A.R.P. and the new valves with low-voltage and low-current filaments. The fact that the latter can be run from dry cells is a great attraction. Good and efficient though it is, the accumulator has the drawback of needing periodic attention, whether you use it or not. The dry cell can be left to look after itself and will remain in good order if put away for months so long as you don't store it in some over-warm spot. Heat has curious effects on dry batteries. A moderate amount of it may increase the activity of the depolariser for a time; in fact, at temperatures a little above 90 deg. Fahrenheit I have known the EMF of cells go up whilst they were under load. But even this

sort of temperature confers short-lived benefits, for it soon causes the paste electrolyte to dry up. Modern "all-dry" portables that I have tried gave a very good account of themselves. They are handy little receivers, remarkably efficient for their size and weight.

Pet Annoyances

TWO stock excuses made by demonstrators in wireless salerooms annoy me beyond words. Here is No. 1. Whilst the set is working, loud and unpleasant noises issue from the speaker. "Don't take any notice of that," remarks the demonstrator; "that's only interference; nothing to do with the set." At that point I usually ask if it can be prevented. The reply is invariably that to do so is the easiest thing in the world; it only needs a special aerial. "Then why haven't you got one?" I ask, and you know the rest. And No. 2. The set under inspection has a poisonous hum. "Don't bother about that; you won't hear it when the programme is coming through." Don't you share my feeling, when you're told that, that you wish you'd brought your gun? If any demonstrator reads this, I do hope he will take it to heart.

Shock-proof and Otherwise

CURIOUS how individual people vary in their susceptibility to electric shocks. I am one of those unfortunate people who execute spectacular leaps when coming into unexpected contact with quite low potentials. The other day I was looking over a field telephone instrument, and, reading in the instructions that its "liveness" could be tested by pressing the buzzer key and applying wet fingers to the line terminals, I proceeded with touching faith to carry out the instructions, except that I thought I'd make the first shot without a preliminary wetting of the fingers. There was no doubt that the instrument was alive—and kicking! My hand and forearm tingled for some time afterwards. Next time I took my Territorial class I described the test to them and asked the nearest man to try it. He put unwetted fingers on the terminals and felt nothing. Having wet

them, he was just able to feel a slight tickling sensation. The rest tried it in turn. Most of them didn't need to wet their fingers; a few proved nearly as shockproof as the first man; only one man withdrew his fingers as hastily as if the terminals had been red-hot. I suppose it all depends on the thickness of the skin and its moistness or otherwise.

Fans for Fans

I'M writing this sitting not far away from the very welcome glow of a good big fire. Still, summer will no doubt come in time, turning our thoughts from fires to fans. If you're thinking of installing one or more in your home to create refreshing breezes in the hot weather, do, I beg of you, choose them with care. There are few more diabolical producers of nasty noises from the loud speaker than fans of certain kinds. Unless you have assured yourself by trial of their innocuousness, or can obtain a satisfactory guarantee of it, it may be wise, provided you have an AC supply, to reject fans containing motors of the commutator type in favour of those driven by induction motors. These latter motors are simpler in design, and in the types used in fans there are no brushes to cause bother; but the great point about them is that they don't give rise to interference with wireless reception. There are, of course, fans with commutator motors which are completely innocent of this crime; but the majority emphatically are not. On the whole, then, the induction motor is perhaps the safest bet for the wireless enthusiast who wants to keep both body and temper cool, and it has other advantages besides.



French Broadcast Sets

A somewhat bizarre tendency was manifest in many of the new receivers shown at the recent Paris Fair. The "de luxe" radio-gramophone illustrated above is housed in a glass-covered cabinet, while the metal lamp support acts as an aerial. Remote control is becoming popular; the control unit seen on the left may be removed from its housing in the receiver and operated at a distant point. Another practical innovation was a battery-fed portable specifically designed for use in a car, but readily removable when required.



Recent Inventions

CONTROLLING SELECTIVITY

THE figure shows a simple arrangement for varying the selectivity of a receiver by the so-called Miller effect. The valve V, which may be the second detector of a superhet., is fed with IF signals at A and is coupled to a LF stage at B. The screening grid is coupled to the HT line through a resistance R, and to the cathode through a condenser C, a switch S, and an optional resistance R₁. This provides three alternative

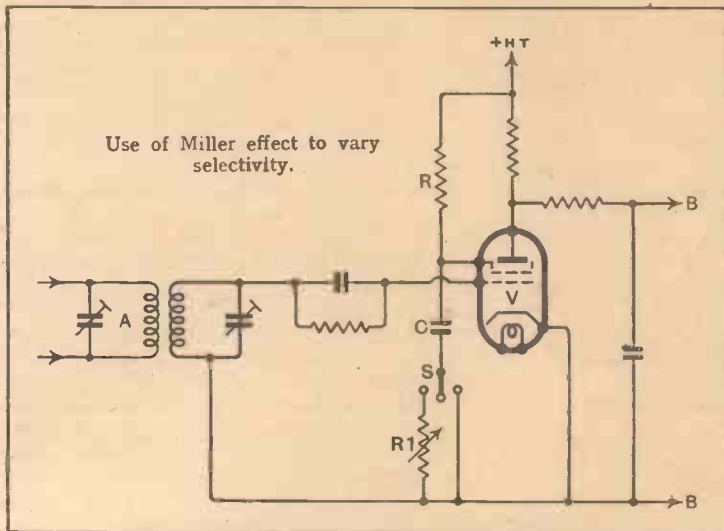

working conditions, as the condenser C may be left open-circuited, as shown, or it may be connected to the cathode, either directly or via the series resistance R₁. Each of these settings gives a different anode impedance, and therefore a different value of "reflected" capacity across the anode and screen-grid, which in turn produces a different degree of damping of the tuned input circuit A. In practice the damping can be varied more or less continuously from 10,000 to 250,000 ohms, to give a corresponding control of the selectivity of the set.

F. T. Lett. Application date, July 14th, 1937. No. 502248.

NEW METHOD OF A.V.C.

ONE method of controlling the amplification of a set in accordance with the incoming signal strength is to apply biasing-voltages, derived from the carrier-wave, to the grids of valves having a variable- μ characteristic. Such valves are inherently liable to cause amplitude distortion.

An alternative scheme, which avoids the use of variable- μ

The British abstracts published here are prepared with the permission of the Controller of H.M. Stationery Office, from specifications obtainable at the Patent Office, 25, Southampton Buildings, London, W.C.2, price 1/- each.

Brief descriptions of the more interesting radio devices and improvements issued as patents will be included in this section

valves, is to control the degree of coupling, say, between the aerial and the first valve, or between two successive valves, automatically and in such a way that as signal strength increases, the coupling is loosened, and vice versa. All the valves of the set

may then have a linear characteristic.

According to the invention, the DC output from one of the IF valves is passed through a small motor of the galvanometer type. This is used to drive two differential condensers, which are connected to two of the tuned circuits in such a manner that they vary the effective coupling between them as the strength of the received signal rises or falls.

L. W. Meyer (communicated by N. V. Philips Gloeilampenfabrieken). Application date July 19th, 1937. No. 502562.

NAVIGATIONAL RECEIVERS

RELATES to a D.F. receiver in which the bearing of a distant transmitter is shown by the trace formed on the fluorescent screen of a cathode-ray tube. When using such an arrangement under conditions of severe interference, it is essential to have extremely selective circuits between the aerial and the cathode-ray tube, though it is desirable that the circuit feeding the associated headphones should not have an equally sharp cut-off, since the wireless operator might then miss an urgent signal from some aircraft or ship which is transmitting slightly off tune.

According to the invention, the cathode-ray circuits are maintained at the required high level of selectivity, though the circuit feeding the operator's headphones is given a band-pass characteristic (so as to receive signals over a wider range of frequencies). There is, however, a sharply resonant peak at the centre of the audible band, in order to allow the operator to iden-

tify the particular signal from the station on which he is taking a bearing.

J. P. Jeffcock. Application date, August 20th, 1937. No. 500592.

ONE VALVE—MANY PURPOSES

A COMBINATION of positive and negative feed-back is used to give to a valve any desired value of AC resistance differing from the actual or specified value. For instance, if a standard type of valve is used throughout the various stages of a receiver the output valve should be given a low value of resistance, since it is coupled to the loud speaker, while on the other hand the first, or RF, stage should be given a high resistance in order to secure high gain and selectivity.

According to the invention, two feed-back paths are provided between the anode and grid, one of which is controlled by output current and the other by output voltage. If the apparent anode resistance of the valve is to be lowered, the feed-back derived from the current output is made regenerative or positive, that derived from the voltage output being made degenerative or negative.

In the figure, V is a pentode feeding the loud speaker S. An

feed-back voltage across the secondary winding of T₁, which is connected as shown from the resistance R₁ to the grid of the pentode via the secondary of the transformer T. On the other hand, the feed-back from the shunt circuit C, R, R₁ is a negative one. The conditions are reversed if it is desired to increase the valve resistance, as would be the case for the HF input amplifier.

The British Thomson-Houston Co., Ltd. Convention date (U.S.A.), January 30th, 1937. No. 503044.

LOUD-SPEAKER IMPROVEMENT

A LOUD-SPEAKER of the kind in which the diaphragm is supported in a frame, so that air has free access to the back as well as to the front of the diaphragm, tends to develop a natural resonance, usually between 60 and 200 c/s, which causes it to "boom" when reproducing speech.

It has already been proposed to remedy this by damping the diaphragm in various ways, but, to some extent, such damping usually affects the upper musical frequencies also, with the result that the high-note reproduction of the loud speaker is not so brilliant as it might be.

According to the invention, the desired effect is produced by using a fabric, instead of the customary felt, as the damping material. The vibration of the diaphragm forces the air to pass to and fro

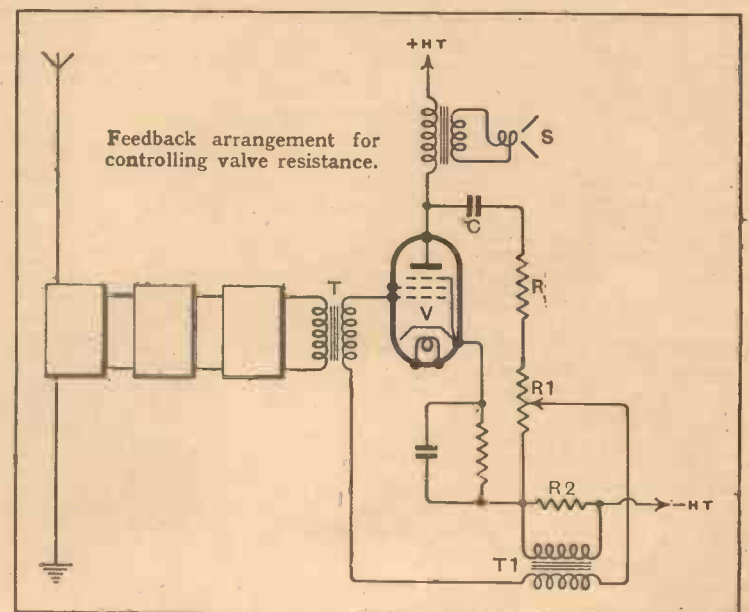

anode shunt circuit is provided, comprising a blocking condenser C, a high resistance R, and a resistance R₁ of lower value. The direct anode-cathode circuit includes, in series with it, a resistance R₂ of 200 ohms, across which is shunted the primary of a transformer T₁. The potential drop across R₂ and the primary of T₁ is in phase with the output current, and produces a positive

through the "pores" of the cloth to produce damping, and the vibration of the cloth itself produces more damping. Velvet and plush are mentioned as the thickest material to be used, though fabrics of more open weave are sometimes to be preferred.

The General Electric Co., Ltd., and F. H. Brittain. Application date September 20th, 1937. No. 501152.

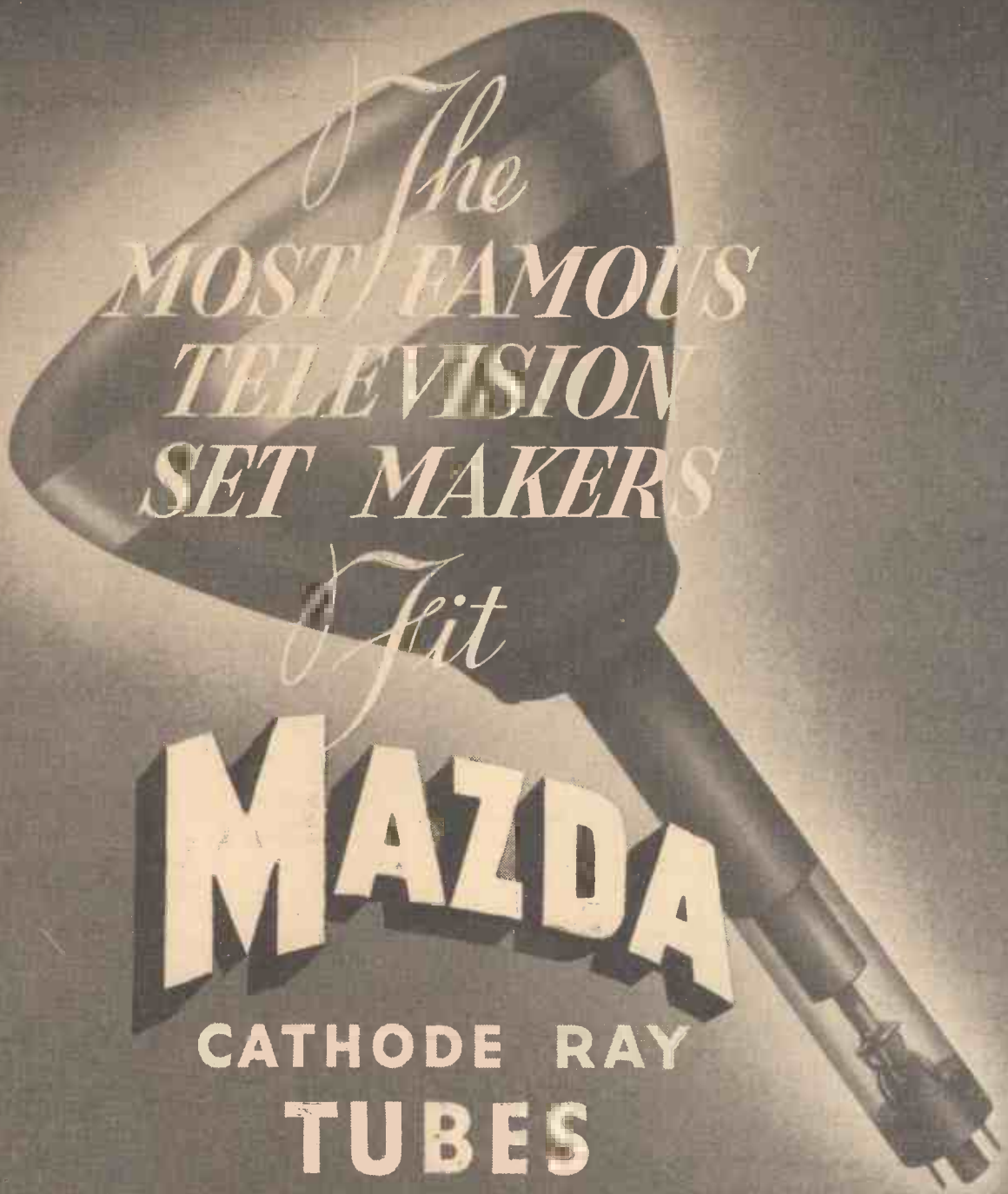

The
**MOST FAMOUS
TELEVISION
SET MAKERS**

Fit
MAZDA
CATHODE RAY
TUBES

AND MAZDA SPECIAL VALVES

**SEE THAT YOUR TELEVISION SET
IS FITTED WITH MAZDA**

Mazda Radio Valves & Cathode Ray Tubes are manufactured in Gt. Britain for the British Thomson-Houston Co. Ltd., London & Rugby and distributed by
THE EDISON SWAN ELECTRIC CO. LTD.  **155 CHARING CROSS RD., LONDON, W.C.2**

For full particulars write to Technical Service Department

Mention of "The Wireless World," when writing to advertisers, will ensure prompt attention.

R.M.352

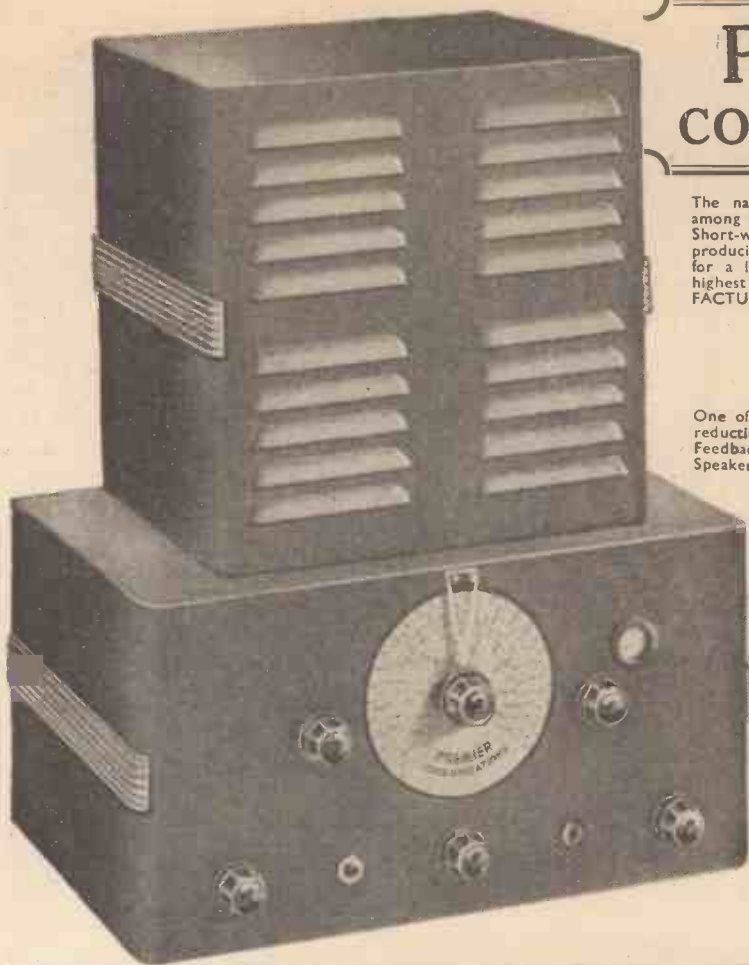

PREMIER "5V5" COMMUNICATIONS RECEIVER

The name of "Premier" is already well known among English amateurs for their wide range of TX, Short-wave, and Public Address Equipment, and in producing the "5V5" we are filling a long-felt need for a low-priced Communications Receiver of the highest possible efficiency, of BRITISH MANUFACTURE.

The Premier "5V5" is a 5-valve A.C. Superhet Communications Receiver of outstanding design, complete in every respect, and incorporating many features never before available at this low price. This Receiver provides full coverage from 12-2000 metres in 5 wave bands.

Band 1.	12-33 metres
Band 2.	30-90 metres
Band 3.	90-200 metres
Band 4.	200-560 metres
Band 5.	850-2000 metres

One of the most outstanding features is an entirely separate band spread condenser fitted with drive reduction, thus enabling any signal to be accurately and instantaneously logged. Feedback effects, always so troublesome in short-wave reception, are entirely avoided by placing the Speaker in a separate steel cabinet to match the Receiver.

Tube Line-Up.—6K8 Triode Hexode Frequency Changer—6F7 I.F. Amplifier and B.F.O.—6Q7 Second Detector, A.V.C. and First Audio—6V6 Output Tetrode—5Y3 Full Wave Rectifier.

Features

5 TUBES—Complete Coverage 12-2000 metres—Illuminated Band Spread Dial—Individual Coils for each band—Beat Frequency Oscillator—A.V.C. Switch—Send-Receive Switch—Iron cored I.F.'s—Litz wound High "Q" Tuning Coils—Aerial Matching Control—Phone Jack—Beam Power Output—Over 4 watts Output—Separate Moving Coil Speaker in steel case to match—5 WAVE BANDS—Separate Band Spread Condenser with Reduction Drive.

PRICE COMPLETE WITH 5 TUBES AND MOVING COIL SPEAKER IN SEPARATE STEEL CASE **£8.8.0**

Deferred terms available

Write for our 90-page 1939 Catalogue, Data Handbook and Valve Manual, price 6d.

PREMIER RADIO CO.,

ALL POST ORDERS TO: JUBILEE WORKS, 167, LOWER CLAPTON RD., LONDON, E.5
CALLERS TO: JUBILEE WORKS Amherst 4723 or 169, FLEET STREET, E.C.4 Central 2833 or 50, HIGH STREET, CLAPHAM, S.W.4. Macaulay 2381.

Covers **CONTINUOUS** fundamental frequency band from **95 Kc. to 40 Mc.**

The **ALL-WAVE**

Avo-Oscillator

Read. Trade Mark. BRITISH MADE.

Covers complete band from 95 Kc. to 40 Mc. by six fundamental ranges. Extended to 80 Mc. by harmonic calibration. Directly calibrated throughout. Externally modulated, internally modulated, or R.F. signal obtained at will. Internal modulation is 30% at 400 cycles, the L.F. signal being available for external use. Double attenuation enables signals to be varied from a few microvolts to 50 millivolts, with a force output of 1 volt.

• Write for fully descriptive leaflet.

Sole Proprietors & Manufacturers
The Automatic Coil Winder & Electrical Equipment Co. Ltd.
Winder House, Douglas Street, London, S.W.1. *Phone: Victoria 34047.

Battery Model
9 Gns.
(Complete with Batteries)
A.C. Mains Model
10 Gns.
Leather Carrying Case: 35/-
DEFERRED TERMS IF DESIRED

A Good Tip

WHEN BUYING AN ELECTRIC SOLDERING IRON

LOOK FOR:—

- PROTECTION OF WINDINGS AGAINST FLUX FUMES AND MOISTURE.
- EFFICIENT HEAT CONDUCTION CONTACT TO TIP.

THIS IRON HAS HERMITICALLY SEALED HEATING ELEMENT GIVING PERMANENT PROTECTION AND MACHINED VALVE-FACE BEVEL FIT CONNECTION TO COPPER TIP FOR QUICK CONDUCTION

IT'S A **STANLEY**

Send for folder SW for other good points about it.

SOLE CONCESSIONAIRES
E. P. BARRUS, LTD
36 UPPER THAMES ST., LONDON, E.C.4

CLASSIFIED ADVERTISEMENTS

NOTICES

THE CHARGE FOR ADVERTISEMENTS in these columns is

12 words or less, 3/- and 3d. for every additional word.

Each paragraph is charged separately and name and address must be counted.

SERIES DISCOUNTS are allowed to Trade Advertisers as follows on orders for consecutive insertions, provided a contract is placed in advance, and in the absence of fresh instructions the entire "copy" is repeated from the previous issue: 13 consecutive insertions 5%, 26 consecutive, 10%; 52 consecutive, 15%.

ADVERTISEMENTS for these columns are accepted up to **FIRST POST** on **MONDAY MORNING** (previous to date of issue) at the Head Offices of "The Wireless World," Dorset House, Stamford Street, London, S.E.1, or on **SATURDAY MORNING** at the Branch Offices, 8-10, Corporation Street, Coventry; Guildhall Buildings, Navigation Street, Birmingham, 2; 260, Deansgate, Manchester, 3; 26a, Renfield Street, Glasgow, C.2.

Advertisements that arrive too late for a particular issue will automatically be inserted in the following issue unless accompanied by instructions to the contrary. All advertisements in this section must be strictly prepaid.

The proprietors retain the right to refuse or withdraw advertisements at their discretion.

Postal Orders and Cheques sent in payment for advertisements should be made payable to **ILIFFE & SONS Ltd.**, and crossed **& Co.** Notes being untraceable if lost in transit should not be sent as remittances.

All letters relating to advertisements should quote the number which is printed at the end of each advertisement and the date of the issue in which it appeared.

The proprietors are not responsible for clerical or printers' errors, although every care is taken to avoid mistakes.

ARMSTRONG'S ★ NEW HEADQUARTERS



★ The illustration above, with its light and shade, enables you to visualise the building as it actually appears.

SO WITH ARMSTRONG CHASSIS! Carefully designed, carefully built and each one individually tested before despatch, they bring to you, in every detail of light and shade, the performance as actually heard in the concert hall. You can verify this by calling for a demonstration: from Mondays to Fridays until 7.30 p.m. and on Saturdays until 5.30 p.m. for the convenience of those who cannot call during the week. In the meantime send for our Illustrated Catalogue, which includes the following outstanding models.

MODEL RF96 Price **£8**

6-V. ALL-WAVE RADIOGRAM CHASSIS
Complete with Matched M.C. Speaker.

Incorporating R.F. Amplifier, 3 wavebands, 17.9-50, 200-550, 1,000-2,000 m., 3 stages of A.V.C., corrected 3½ watts output.

MODEL AW93PP Price **10 gns.**

9-V. ALL-WAVE RADIOGRAM CHASSIS

3 wavebands, R.F. Pre-Amplifier, 3 stages of A.V.C. and 8 watts R.C. coupled Triode P.P. output.

MODEL AW125PP Price **17 gns.**

12-V. ALL-WAVE RADIOGRAM CHASSIS

5 wavebands, 12-550 continuous, 1,000-2,000 m., R.F. Pre-Amplifier, 2 I.F. stages with Variable Selectivity. Manual R.F. gain control and 10 watts R.C. coupled Triode P.P. output.

ARMSTRONG MANUFACTURING CO.,
WALTERS ROAD, HOLLOWAY, LONDON, N.7
(Adjoining Holloway Arcade).

Telephone: NORTH 3213.

NUMBERED ADDRESSES

For the convenience of private advertisers, letters may be addressed to numbers at "The Wireless World" Office. When this is desired, the sum of 6d. to defray the cost of registration and to cover postage on replies must be added to the advertisement charge, which must include the words Box 000, c/o "The Wireless World." All replies should be addressed to the Box number shown in the advertisement, c/o "The Wireless World," Dorset House, Stamford Street, London, S.E.1. Readers who reply to Box No. advertisements are warned against sending remittances through the post except in registered envelopes: in all such cases the use of the Deposit System is recommended, and the envelope should be clearly marked "Deposit Department."

DEPOSIT SYSTEM

Readers who hesitate to send money to advertisers in these columns may deal in perfect safety by availing themselves of our Deposit System. If the money be deposited with "The Wireless World," both parties are advised of its receipt.

The time allowed for decision is three days, counting from receipt of goods, after which period, if buyer decides not to retain goods, they must be returned to sender. If a sale is effected, buyer instructs us to remit amount to seller, but if not, seller instructs us to return amount to depositor. Carriage is paid by the buyer, but in the event of no sale, and subject to there being no different arrangement between buyer and seller, each pays carriage one way. The seller takes the risk of loss or damage in transit, for which we take no responsibility. For all transactions up to £10, a deposit fee of 1/- is charged; on transactions over £10 and under £50, the fee is 2/6; over £50, 5/-. All deposit matters are dealt with at Dorset House, Stamford Street, London, S.E.1, and cheques and money orders should be made payable to Iliffe & Sons Limited.

SPECIAL NOTE.—Readers who reply to advertisements and receive no answer to their enquiries are requested to regard the silence as an indication that the goods advertised have already been disposed of. Advertisers often receive so many enquiries that it is quite impossible to reply to each one by post. When sending remittances direct to an advertiser, stamp for return should also be included for use in the event of the application proving unsuccessful.

NEW RECEIVERS AND AMPLIFIERS

R.

RADIO CLEARANCE, Ltd.

63, High Holborn, W.C.1. Phone: Holborn 4631.

GUTHMAN MC Murdo Silver Communication Receiver.

WE are Sole Distributors for the United Kingdom of Above Product.

CIRCUIT Superhet with double regeneration obtained at signal frequency and also at intermediate frequency. As a result, very high sensitivity and selectivity are obtained.

CONTROLS.—R. meter, silencer, tone, aerial trimmer, A.F. gain, selectivity, beat oscillator, receiver-send A.V.C. B.O. on/off; assembled with valves but unwired, £17; wired and aerial tested, £18/18.

ROTHERMEL Piezo High Fidelity Speakers.

MODEL R.95, 7in. cone, will handle 5 watts; 9/11.

MODEL R105, 10½in. cone, will handle 6 watts; 11/6.

ABOVE can be used in conjunction with Existing Moving Coil Speaker, connect across primary of speech transformer; to use independently a choke must be connected between the receiver or amplifier output; in the event of push-pull connect to the 2 anode terminals of output transformer, ignoring C.T.

T.C.C. 8 mid. 450-volt Working Wet Electrolytics, can type, 1 hole fixing; 1/6 each.

POLAR ½ and ¼ Resistances, good selection; 4/6 a gross.

PHILCO American Mains Transformers.—200-250-volt, 6.5-volt 3-amp., 5-volt 2-amp.; 7/6 each.

BRITISH Belmont.

RECEIVERS and Chassis Still Available from Stock; as previously supplied.

RECEIVERS, with valves; £7/7.

FOR One Month Only; chassis with valves; £5/7/6.

ALL Lines Previously Advertised Still in Stock.

ALL Orders Over 5/- Carriage Free; under this amount sufficient postage must be included with order.

ALL Enquiries Must Enclose 1½d. Stamp.

RADIO CLEARANCE, Ltd., 63, High Holborn, W.C.1. Telephone: Holborn 4631. [8593]

NEW RECEIVERS AND AMPLIFIERS

* **DEGALLIER'S** "Challenge Radio Corporation."

SEND 2d. stamp for Handsome Illustrated Catalogues. Selling of our Superb Range of Receivers; direct public sales policy (saves you 40%), most exceptional value on the market, from a T.R.F. Midget at £3/5 to a 19-valve general purpose receiver, 6 bands, with two P.A. speakers, at 30 gns. 6-page brochure of *Wireless World* report on this set is available; car radio; any known American valve, all 5/6 each; also American P.A. speakers, cabinets, and the Challenger 6-valve A.C. tuning unit, 5 bands 6-10, 12.8-50, 65-200, 190-550, 900-2,000 metres. Hours business 11 a.m. until 9.30 p.m.

DEGALLIER'S, 31, Craven Terrace, London, W.2. Paddington 6492. Nearest point Lancaster Gate Tube Station. [8515]

ARMSTRONG Co.—After many years at our old premises at Camden Town we have removed to a new building in Walters Rd., Holloway, N.7 (see displayed advertisement).

ARMSTRONG Amplifier Division Has Removed to New Premises at 94, Camden Rd., N.W.1. Enquiries for High Fidelity amplifiers and simple feeder units should be made to this address. Catalogue of this apparatus will be forwarded free to those interested.

ARMSTRONG Co. (Amplifier Division), 94, Camden Rd., N.W.1. [8518]

USED SETS FOR SALE

HALLICRAFTER

£12 or Near Offer.—Hallicrafter Sky Chief Communication receiver, £25 new, only 3 months old.—Pritchard, 42, Green Lane, Purley, Surrey. [8629]

HALLICRAFTER, "New Skyrider 25," MC.0.54 to 32, with speaker, as new, in original packing, cost £37/10. With rotary converter 220v. D.C. into 230v. A.C., 200 watts output, cost £21; what offers?—Marchal, 143, Whitfield St., London, W.1. [8615]

CAR RADIO

NEW Caradios from £4/10, used Caradios from £3; suppressors, 1/- each.—Cook, 41, Glebe Ave., Kenton. [8633]

1939 Models from 4½ gns.; 6 new car aeriels, from 9/6; trade enquiries solicited; lists free.—Shippers, 18, Corporation St., Manchester. [0622]

"CROSSLEY" and "Traveler" Sets, latest models, aeriels and all accessories; prices incomparable.—Radio and Sound Equipment, 3, Lytton Close, London, N.2. [8618]

MASTERADIO, Ltd., announce the New Masteradio Junior, the British-made car radio with press-button tuning, 6-valve circuit, long and medium wave-bands; fits any car; price 10½ gns., including aerial.

OTHER Models at 13½ gns., 16½ gns., and 22½ gns.—Full details from Masteradio, Ltd., Newton St., London, W.C.2. Phone: Holborn 2128-9. [8646]

PARTRIDGE OUTPUT TRANSFORMERS

are as free from harmonic distortion as it is possible to make them. Mr. Partridge is a recognised authority on transformer theory and application. You cannot do better than go to the fountain head.

Send your enquiries to:—



N. Partridge

B.Sc., A.M.I.E.E.

King's Bldgs., Dean Stanley St., London, S.W.1.

Phone: VICTORIA 5035.

PUBLIC ADDRESS

VORTEXION P.A. Equipment.
IMITATED, but unequalled.
WE invite You to a Demonstration.
A C.-D.C. Dance Band Amplifier, 10 watts output, complete in case, with moving coil microphone, speaker and cables, weight 22lb.; 12 gns.
A C.-20 15-20-watt Amplifier, 38-18,000 cycles, independent mike and gram. inputs and controls, 0.037 volts required to full load, output for 4, 7.5, and 15 ohms speakers or to specification, inaudible hum level; ready for use; 8½ gns., complete.
C.P. 20 12-volt battery and A.C. Mains Model, as used by R.A.F., output as above; 12 gns.
A C.-20, in portable case, with Collaro motor, Piezo pick-up, etc., £14; C.P.20 ditto, £17/17.
50-WATT Output 6L6s, under 60-watt conditions, with negative feed back, separate rectifiers for anode screen and bias, with better than 4% regulation, level response, 20-25,000 cycles, excellent driver, driver transformer, and output transformer matching 2-30 ohms impedance electronic mixing for mike and pick-up, with tone control, complete with valves and plugs; £15.
COMPLETE in Case, with turntable B.T.H. Piezo pick-up and shielded microphone transformer; £20.
80-WATT Model, with negative feed back; £25, complete.
120-WATT Model, with negative feed back; £40, complete.
250-VOLT 250 m.a. Full Wave Speaker, field supply unit; 25/-, with valve.
ALL P.A. Accessories in Stock; trade supplied.
VORTEXION, Ltd., 182, The Broadway, Wimbledon, S.W.19. Phone: Lib. 2814. [8241]

"**PARTRIDGE P.A. Manual**," free to trade, from N. Partridge, B.Sc., A.M.I.E.E., King's Buildings, Dean Stanley St., London, S.W.1. [0631]
QUALITY Amplifiers and Microphone Equipments for Hire or Permanent Installation.—Harmony House, 116, Cambridge Rd., Southport. [8505]
ALEXANDER BLACK, Ltd.—Consult us on sound installations, temporary or permanent; booklet on request.—55, Ebury St., S.W.1. Sloane 6129. [0597]
PUBLIC Address Contractors Can Hire P.A. Vans, loud speakers, microphones and equipments of all types from Hire Dept., Gramplan Reproducers, Ltd., Kew Gardens, Surrey. Tel.: Richmond 1175-6-7. [0618]
RIBBON Microphones, 7 models, from £3/19/6, list free; 15 watt high gain, high fidelity, 4 stage amplifier for ribbon microphones, £12/10; 30 watt ditto, £18.—Holiday and Hemmerdinger, Ltd., 74, Hardman St., Manchester. [8622]

NEW MAINS EQUIPMENT

VORTEXION Supply G.P.O., B.B.C., L.P.T.B. Why not you?
ALL Models Super Shrouded, primaries screened and tapped, 200-250v., filaments C.T.
ANY Model Fitted 5v. or 6.3v. Filaments if Required:
500—0-500 150 m.a., 4v. 4a., 2.5a., 4v. 2a., 4v. 2a., 4v. 2a., 35/-; 400 or 350v., same price.
500—0-500 120 m.a., 4v. 4a., 4v. 2.5a., 4v. 1.2a., 4v. 1.2a., 28/-; 400v. or 450v., same price.
425—0-425 150 m.a., 4v. 8-10a., 4v. 2.5a., 4v. 1a., 4v. 1a., 32/-.
350—0-350 120 m.a., 4v. 4a., 4v. 2.5a., 4v. 1.2a., 21/-; with extra 4v. 6a., 25/-.
350—0-350 75 m.a., 4v. 2.4a., 4v. 1.2a.; 18/-.
250—0-250 60 m.a., 4v. 2.4a., 4v. 1.2a.; 15/-.
AUTO Transformers, 100-120 to 200-240v., 80 watts, 11/-; 120 watts, 14/6; 200 watts, 21/-; 250 watts, 25/-; 300 watts, 28/-; 500 watts, 47/6.
W.W. Q.A. Output Transformer; 21/-.
MICROPHONE Transformers, in heavy magnetic shielding; 12/6.
CHOKES—30h. 60 m.a., 7/6; 7-13h., 120 m.a., 12/6; 30h. 150 m.a., 15/-; 25h. 150 m.a., 21/-.
TRANSFORMERS and Chokes to Any Specification.
CAR Battery Charger, 6 and 12v., 1½ to 2 amperes; 30/- complete.
VORTEXION, Ltd., 182, The Broadway, Wimbledon, London, S.W.19. Telephone: Liberty 2814. [8642]

NEW LOUD-SPEAKERS

SINCLAIR Speakers for All Types.—Alma Grove, Copenhagen St., N.1. [0603]
GET the Most Out of Your Set with an Epoch Loud Speaker, the supreme reproducer.
HALFORD RADIO, 31, St. George St., W.1.
SOLE Manufacturers of Epoch Loud Speakers, output transformers, etc., and also of the famous Halford Phantom Radio Set. [0632]
SAVE Pounds.—1½d. stamp for list British and American P.A. Speakers.—Degallier's, 31, Craven Terrace, London, W.2. [8554]
BAKERS New Corner Horn Speakers, Triple cone conversions; from 29/6, and surplus speaker bargains.—Bakers Selhurst Radio, 75, Sussex Rd., South Croydon. [8608]

VORTEXION 15W
Type CP20 AC and 12-VOLT DC AMPLIFIER

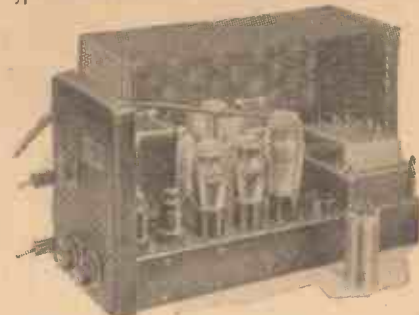

THIS small Portable Amplifier, operating either from AC mains or 12-volt battery was tested by "THE WIRELESS WORLD," October 1st, 1937, and has proved so popular that at Customers' demand it remains unaltered except that the output has been increased to 17.2 watts and the battery consumption lowered to 6 amperes. Read what "The Wireless World" said:—

"During tests an output of 14.7 watts was obtained without any trace of distortion so that the rating of 15 watts is quite justified. The measured response shows an upper limit of 18,000 c/s and a lower of 30 c/s. Its performance is exceptionally good. Another outstanding feature is its exceptionally low hum level when AC operated even without an earth connection. In order to obtain the maximum undistorted output, an input to the microphone jack of 0.037 volt was required. The two independent volume controls enable one to adjust the gain of the amplifier for the same power output from both sources, as well as superimpose one on the other, or fade out one and bring the other up to full volume. The secondary of the output transformer is tapped for loudspeakers or line impedances of 4, 7.5 and 15 ohms."
AC and 12-volt CHASSIS with valves, etc. £12 12 0
Or in Rexine Case with Collaro Motor, Piezo P.U. and Mike Transformer..... £17 17 0
AC only CHASSIS with valves, etc. £8 18 6
Or in Rexine Case with Collaro Motor, Piezo P.U. and Mike Transformer..... £14 0 0
Gauze Case for either chassis 12/6 extra.
SEND NOW FOR FULL DETAILS.

Vortexion Ltd., 182, The Broadway, Wimbledon, S.W.19. Phone: Liberty 2814.

KINGSTON
SURREY

UNIQUE OPPORTUNITY FOR A
WIRELESS TRADER
IN THE HEART OF THE TOWN

NEW BUILDING. PROMINENT POSITION
REASONABLE RENTAL

SOLE AGENTS
HEALEY & BAKER
SHOP SPECIALISTS

29, ST. GEORGE STREET, HANOVER
SQUARE, LONDON, W.1

TELEPHONE: MAYFAIR 2965 (14 LINES)

Pamphonic
AMPLIFIERS

Pamphonic Reproducers Ltd. (Associated with PYE Ltd.)
45, St. Pancras Way, London, N.W.1.
Phone: EUSTON 1727.

LOUD-SPEAKERS

SECOND-HAND, CLEARANCE, SURPLUS, ETC.
V AUXHALL UTILITIES, 163a, Strand, W.C.2.—Rola G.12 P.M. speakers, 62/6; G.12 energised, 50/-; Rola 8in. P.M., 14/9; all brand new with transformers. [8640]
3,000 Speakers from 5/6 each, P.M. and energised, 4ln. to 14in., including several Epoch 18in.—Sinclair Speakers, Alma Grove, Copenhagen St., N.1. [0591]

TELEVISION

MURPHY Television Set, as new, under guarantee; £26/10.—Box 285, c/o The Wireless World. [8632]

TRANSMITTING APPARATUS

A MATEUR Selling Transmitting Receiving Equipment; stamp.—Box 286, c/o The Wireless World. [8631]

CRYSTALS, 1.7 and 3.5 mc., 5/- each; all guaranteed and tested O.K.—Radio G6MY, Morley, Leeds. [8636]

A.C.S. RADIO, specialists in short-wave apparatus, communication receivers, including Hallicrafters, National and R.M.E. transmitting equipment, valves and components.—Send for free catalogue to A.C.S. Radio, 16, Gray's Inn Rd., W.C.1. Holborn 9894-5. G2NK, Technical Manager. [0550]

G5NI—The oldest and largest distributor of amateur equipment, transmitting and receiving; short-wave catalogue, 1½d.; G5NI 70-page Manual, 7½d., post free; authorised direct distributor for Collins, National, R.M.E., Thordarson, Hammerlund, Biley, Taylor, Eimac, etc., etc.—44, Holloway Head, Birmingham. [0531]

CABINETS

A CABINET for Every Radio Purpose.
CONVERT Your Set into a Radiogram at Minimum Cost; surplus cabinets from noted makers under cost of manufacture (undrilled); 30/- upwards; motors at wholesale prices.
"FIT-A-GRAM" Cabinet, 31 x 17 x 15; 21/-.

UNDRILLED Table Console and Loud-speaker Cabinets from 3/6.
INSPECTION Invited; photos loaned to country customers.

H. L. SMITH and Co., Ltd., 289, Edgware Rd., W.2. Tel.: Pad. 5891. [0485]

CLEARANCE Sale!!—Radiogram and television cabinets, prices slashed! 10 gns. worth for 50/-! 5 gns. worth for 20/-!—Write, wire, phone or call. Cameo Co., 23, Denmark St., W.C.2. (Tem. 5900.) [8527]

DEGALLIER'S for the Finest Obtainable American Cabinets, Table Console and Radio Grams; also Record Changers, 5 gns. Send 1½d. stamp for reprints from actual photographs.—Degallier's, 31, Craven Terrace, Lancaster Gate, London, W.2. [8553]

DYNAMOS, MOTORS, ETC.

D.C.-A.C. Convertors, motors, all voltages, for sale and wanted.—Easco, 18w, Brixton Rd., S.W.9. [0558]

ALL Types of Rotary Convertors, electric motors, battery chargers, petrol-electric generator sets, etc., in stock, new and second-hand.

A.C.-D.C. Conversion Units for Operating D.C. Receivers from A.C. Mains, 100 watts output, £2/10; 150 watts output, £3/10.

WARD, 46, Farringdon St., London, E.C.4. Tel.: Holborn 9703. [0518]

ELECTRADIX Rotary Convertors for A.C. Radios on D.C. Mains; alternators 50 to 500 cycles; mains motors and motor generators for 1 to 600 cells; petrol engines and switchgear.—218, Upper Thames St., London, E.C.4. [0619]

RECORDING EQUIPMENT

ALL Recording Discs and Materials in Stock; tracker units, £4/7/6; recording motors, £3/17/6.—Write for further details, Will Day, Ltd., 19, Lisle St., W.C.2. [0595]

VALVES

ALL Types of American Tubes in Stock of Impex and Arcturus makes at competitive prices.

WE Can Also Supply a Full Range of Guaranteed Replacement Valves for Any British non-ring, American or Continental type at an appreciably lower price.

SEND for Lists of These, and also electrolytic condensers, line cords, resistances, etc.

CHAS. F. WARD, 46, Farringdon St., London, E.C.4. Tel.: Holborn 9703. [0452]

A MERICAN, 2/9; 1,000 non-ring British, from 1/9; bargains galore; lists free.—Shippers, 18, Corporation St., Manchester. [0607]

METROPOLITAN RADIO SERVICE—Special offer. American valves, in makers' cartons, 3/- each; Octals, 3/6 each; American valves, first grade, in all types; trade supplied.—1021, Finchley Rd., N.W.11. Speedwell 3000. [0436]

COMPONENTS

SECOND-HAND, CLEARANCE, SURPLUS, ETC.

PREMIER SUPPLY STORES.

PLEASE See Our Displayed Advertisement on page 7. [0488]

SOUTHERN RADIO, 46, Lisle St., London, W.C. Ger-rard 6653.—Stocks of receivers and replacement components, as previously advertised. [8548]

COMPONENTS—SECOND-HAND

CLEARANCE, SURPLUS, ETC.

ROGERS RADIO SPARES.

ALL Types of Speakers, gramophone motors, electro-litics, meters in stock; send for list.—36, Newnham Terrace, S.E.1. [8645]

VAUXHALL.—Hivac valves, all types. Flat sheet aluminium, 12in. x 12in. 3/-. 18in. x 18in. 5/6.

VAUXHALL.—T.C.C. dry, 8 mfd., 2/6; 600v. aluminium containers; T.C.C. 600v. dry, cardboard containers, 8 mfd., 1/9.

VAUXHALL UTILITIES, 163a, Strand, W.C.2.—Ask for free list; metal rectifiers, HT10 10/-. HT9 9/-. [8641]

RYALLS RADIO, 280, High Holborn, London, W.C.1, offer new goods, post free.

ELLIPTICAL Speakers, Celestion, suitable Ekco replacements, 750 and 1,250 ohms, less transformers, speech 25 ohms, new, handle 8 watts, carry up to 120 m.a.; 5/6 each.

AMPLIFIERS, A.O. 200-250v. output 16 watts A.C. from pair 6L6 push pull, 3 stage, ample volume for driving extra speakers available. Complete with valves, and pair of elliptical speakers, wired up ready for use; 72/6, carriage paid.

GARRARD AC Induction Type AC7a Gramophone Motors, with pick-ups complete, 200-250v., 12in. turntable and unit plate, auto stop, speed regulator, new; 32/6 each.

SPEAKERS, pairs, brand new, elliptical cone speakers, made by first class firm, quality of reproduction outstanding, push-pull pentode transformer, fields 325 ohm for smoothing choke, 8,600 as bleeder, circuit available, handle 10-15w.; 14/- pair.—Ryalls Radio, see above. [8374]

MAINS RADIO DEVELOPMENT Co. Offer Immediate Delivery, carriage paid, call mornings; telephone Tudor 4046; stamp for list 227A.

DUBILIER Mica Tag Condensers, 0.00005, 0.0001, 0.0002, 0.0003, 0.0005 mfd.; 3d., 2/6 dozen.

ERIE 1-watt Colour Coded Unused Resistors, any size, 50 ohms to 5 megohms, your selection; 3d., 2/6 dozen; 2-watt, 6d.

CENTRALAB Latest Potentiometers, long standard spindle, unused, all sizes, 5,000 ohms-2 megohms; 2/-. with mains switch 2/3.

TUBULAR Condensers, 400-volt working, wire ends, best make, 0.0001-0.05 mfd., 4d.; 0.1 mfd., 4d.; 0.25, 0.5 mfd., 6d.

CLIX Unused Chassis Valveholders, 5-pin, 7-pin. 3d. each; all American sizes, 6d. each; best sleeving, 1 1/2 yard.

FIFTY Unused N.S.F. 1/4. 1. 2-watt Resistors, wire ends, marked, colour coded, 20 different useful sizes in each parcel; 50 for 2/6 only.

MAINS RADIO DEVELOPMENT Co., 4-6, Muswell Hill Rd., London, N.6. Tudor 4046. [8569]

MOLLARO—A.C./D.C. Record-changers, 200-250, plays eight 10in. or 12in. records, mixed, also incorporates repeater and rejector, limited quantity, £5/5, in sealed cartons.

HENRY'S, 72, Wellington Av., Stamford Hill, N.15. Stamford Hill 2907. [8216]

ANGLO-AMERICAN RADIO, Ltd., for receivers, short-wave equipment, signal shifters, Meissner all-wave tuners. Quality counts. Particulars on request.—59, New Oxford St., W.C.1. [8630]

MANUFACTURERS' Surplus 10in. Energised Speakers, 1,000 ohms, pentode transformer, 9/6; motor operated press button assemblies, complete, 22/6.—Ambassador Radio, Brighouse, Yorks. [8626]

3 WAVE-BAND Tuning Packs for British Valves, aligned and tested; 3-gang H.F., F.C., battery or mains, 32/6 only; 465 K/C IFTs, for above, 2/6 each.—S.A. Radio, 293, Norwood Rd., S.E.24. [8605]

Wanted

PAIR of McMichael Dimic Plug-in Medium Wave Coils, 200 metres.—Osborne, 30, Forest Rd., Bath. [8625]

SIMPSON Turntables, in good order; state price.—200T, 17, Sylvan Ave., N.W.7. [8634]

REPAIRS AND SERVICE

"SERVICE with a Smile."

AMERICAN Valves, spares, linecords, rewinds; repairs of all types of American and British receivers.—F.R.I., Ltd., 22, Howland St., W.1. Museum 5675. [0434]

LOUD-SPEAKER Repairs, British, American, any make, 24-hours service; moderate prices.—Binclair Speakers, Alma Grove, Copenhagen St., N.1. [0590]

GUARANTEED Repairs Any Transformers, choke, motor armature, converter, dynamo, etc.; keenest prices, immediate quotation, prompt, dependable service.—See below.

L.T.P. (LONDON TRANSFORMER PRODUCTS, Ltd.), 1, Willesden, N.W.10. Willesden 6486 (3 lines). [6892]

MAINS Transformer Service, Repairs, rewinds, or construction to specification of any type, competitive prices and prompt service.—Sturdy Electric Co., Dip-ton, Newcastle-on-Tyne. [0516]

METROPOLITAN RADIO SERVICE.—Guaranteed repairs to American and British receivers; American valves, service parts and rewinds; trade supplied.—1021, Finchley Rd., N.W.1. Speedwell 3000. [0435]

DEGALLIER'S "Reliable Service With a Written Guarantee." First class workmanship, lowest prices; all British and American receivers; let American specialists do the job. 48-hour service.—Degallier's Ltd., 31, Craven Terrace, London, W.2. Pad, 6492. [8552]

REPAIRS to Moving Coil Speakers a Speciality; cones and coils fitted, fields altered; prices, including eliminators, quoted; loud-speakers, 4/-; L.F. and output transformers, 4/-, post free; guaranteed satisfaction; trade invited, estimates free; prompt service.—Loud-Speaker Repair Works, 5, Balham Grove, London, Battersea 1321. [0394]

SPECIFIED BY THE EXPERTS

For use in The Wireless World
MAGNETIC TELEVISION RECEIVER
Two S.S. type 10/120
SMOOTHING CHOKES
Price 13/6 each

In accordance with Wireless World practice, these Chokes were specified only after test in the actual receiver under working conditions. . . So for Quality and Reliability's sake follow the Designer's Recommendation.

May we send YOU our latest Catalogue and Technical Manual . . . PRICE 6d.

Specified by the Experts



MARLBOROUGH RD., UPPER HOLLOWAY, LONDON, N.19. (Contractors to the G.P.O., etc.)

Hours of Business—Monday to Friday, 8.30 a.m. to 6 p.m. SATURDAYS CLOSED



THE NEW 70 RANGE, BRITISH MADE

TAYLOR-METER

ONLY COSTS £10.10.0 AND COVERS

D.C. VOLTS 0.002 to 2,000 in 14 Ranges. A.C. VOLTS 0.2 to 2,000 in 12 Ranges. OUTPUT VOLTS 0.2 to 2,000 in 12 Ranges. D.C. AMPS. 10 microamps. to 20 amps. in 16 Ranges. A.C. AMPS. 10 microamps. to 5 amps. in 6 Ranges. OHMS 0.1 ohms to 5 meg. in 4 Ranges, with internal battery. DECIBELS -18 to +60 in 6 Ranges. CAPACITY 0.0002 to 100 mids. in 4 Ranges. INDUCTANCE 0.2 to 1,000 H in 2 ranges. Special inexpensive adaptors are made to extend these ranges still further. * With Adaptor No. 312.

Each instrument is hand calibrated & guaranteed. Can we send you full details?

TAYLOR ELECTRICAL INSTRUMENTS Ltd. 45, FOUBERT'S PLACE, REGENT ST., LONDON, W.1

THE INSTITUTE OF WIRELESS TECHNOLOGY (Founded in 1925. Incorporated).

PROFESSIONAL MEMBERSHIP

The advantages of professional membership are open to all qualified wireless engineers.

Full information, with syllabus, may be obtained from the Secretary, Institute of Wireless Technology, 4, Vernon Place, Southampton Row, London, W.C.1. Phone: Holborn 4879.

SITUATIONS VACANT

AIR MINISTRY.

DIRECTORATE of Signals.

APPLICATIONS are invited for Appointment as an Assistant Signals Officer in the Civil Aviation Signals Service.

THE commencing salary will be determined according to qualifications and experience, within the scale £350 rising by annual increments of £18 to £500 per annum.

THE Qualifications Required are:—

EDUCATION to Degree Standard in Light Electrical Engineering.

EXPERIENCE in the Design of Modern Radio Transmitters and Receivers.

PREFERENCE will be given to candidates who have not reached their 45th birthday, and who have the following additional qualifications:—

EXPERIENCE in the design, testing and installation of aircraft radio equipment.

A GENERAL Knowledge of the Application of Radio Aids in Aviation.

ADMINISTRATIVE Experience.

THE Officer will be largely concerned with approval of new types of aircraft radio apparatus, and his duties will be mainly administrative, but may involve occasional flying as an observer.

SUBJECT to a period of satisfactory probation, the selected candidate will be eligible for consideration for a post on the permanent establishment when vacancies arise.

REQUESTS by postcard for forms of application should reach the Under-Secretary of State, Air Ministry (S.I.e.), Adastral House, Kingsway, not later than July 10th, 1939, and the completed forms must be returned by July 14th, 1939. [8602]

AIR MINISTRY.

A NUMBER of Vacancies Exist for Technical Officers and Assistants II and III at Various Royal Air Force Stations for Work in Connection with the Development, installation and maintenance of wireless equipment.

THE Qualifications Required Are:—

(A) Education to degree standard or equivalent in Physics or electrical engineering, or a sound technical training.

(B) Workshop or laboratory experience in the development of radio communication equipment.

A KNOWLEDGE of the Operation and maintenance of a Royal Air Force wireless equipment would be an advantage.

SALARY Scales Are:—

B210.—Technical Officers: £275 by £18-£455 by £25-£580 (men); £275 by £12-£347 by £18-£464 (by £25-£580 in exceptional cases) (women).

B211.—Assistants II.—£315 by £12-£385 (men); £265 by £12-£315 (women).

B212.—Assistants III.—£130 by £12-£214 (efficiency bar) by £12-£310 (men); £130 by £12-£214 (efficiency bar) by £12-£260 (women).

THE Appointments Will be Non-pensionable in the first instance.

REQUESTS for the Necessary Form of Application should be Addressed to the Under-Secretary of State, Air Ministry (S.2A/B.8019), Berkeley Square House, Berkeley Square, W.1, quoting the appropriate reference number and enclosing a stamped addressed envelope. [8597]

DEPARTMENT of Scientific Research and Experiment, Admiralty.

APPLICATIONS are invited for a vacant post of Technical Officer (Male) in the Admiralty Technical Pool for service initially at H.M. Signal School, Portsmouth.

2 Every candidate must be a natural-born British subject, the child of a person who is or was at the time of death a British subject.

3 Candidates must have had a sound practical engineering training and should preferably possess a good honours degree in electrical engineering.

4 The work required to be performed is of a technical nature in connection with Admiralty shore wireless stations at home and abroad. The successful candidate must have had practical experience of the planning of wireless stations and preferably also some experience of erection work. He will be required to be familiar with power-supply problems, with the general operation of wireless apparatus, both receiving and transmitting, and direction finding, and to be capable of dealing with the mechanical design of large and complex aerial systems. A knowledge of the civil engineering side would be an advantage.

5 The post is pensionable under the Superannuation Acts.

6 The salary scale for technical officers is £275-£18-£455 (efficiency barrier)-£25-£580, with extension in certain cases by £25 to £680. Successful candidates normally enter at the minimum of the scale, but in special cases consideration will be given to the payment of an initial salary higher than the minimum of the scale, but not greater than £455, according to the age, qualifications and experience of the candidate.

7 Technical Officers are eligible for promotion by merit to the higher ranks of the Technical Pool, which contains the following posts:—

SENIOR Technical Officer; £680-£25-£800 p.a.

PRINCIPAL Technical Officer; £850-£30-£1,050 p.a.

CHIEF Technical Officer; £1,050-£30-£1,250 p.a.

8 Applications, giving full name, date of birth, particulars of qualifications and experience and accompanied by copies of testimonials, should be forwarded to the Secretary of the Admiralty (C.E. Branch) not later than July 14th, 1939, quoting Reference Number C.E. 7040/39.

9 Application forms are not required. [8643]

SITUATIONS VACANT

WAR DEPARTMENT.

STAFF for Scientific Research.

SUPERINTENDENT Required for a War Department Experimental Establishment in the South of England.

THE duties include the organisation and supervision of experimental research and development for military purposes in radio and electrical engineering, acoustics and illumination engineering. Applicants must possess first-class qualifications and experience in electrical engineering or applied physics, and should preferably have had training and/or experience in workshop and drawing office practice. Experience in the organisation of research and experimental work, and a knowledge of the radio and electrical industries essential.

SALARY Scale: £1,050, rising by annual increments of £30 to £1,250 a year.

THE Federated Superannuation System for Universities will apply; the War Department contributes approximately 10 per cent. of salary, and the individual contributes approximately 5 per cent. Ex-members of H.M. Forces given preference, other things being equal.

APPLICATION Forms Obtainable by Postcard from the Under-Secretary of State (C.5.), The War Office, London, S.W.1, and to be lodged by 7th July, 1939. Quote Appts. 151.(G). [8617]

CROWN AGENTS FOR THE COLONIES.

COLONIAL Government Appointments.

APPLICATIONS from Qualified Candidates are Invited for the Following Post:—

WIRELESS Engineer Required for the Posts and Telegraphs Department, Gold Coast, for three years, with possible permanency; salary £450, rising to £720 a year; free passages and quarters and liberal leave on full salary; candidates, age 27-37, must possess the City and Guilds Certificate in radio communication, telephony and telegraphy, and have a thorough theoretical and practical knowledge of commercial wireless transmitters and receivers; they must be able to instal and maintain a wireless station, and to supervise repairs in the Department's workshops; preference will be given to General Post Office employees with some knowledge of modern trunk line circuits and to candidates with a knowledge of Morse and an ability to operate.

APPLY at Once by Letter, stating age, whether married or single, and all particulars of qualifications and experience, and mentioning this paper, to the Crown Agents for the Colonies, 4, Millbank, London, S.W.1, quoting M/5976. [8627]

WAR DEPARTMENT (and Later for Ministry of Supply When Formed).

STAFF for Scientific Research.

APPLICATIONS Invited from Adult Male Candidates for the Undermentioned Appointments. Successful candidates will be posted in the first instance to the Bawdsey Research Station, Woodbridge, Suffolk, and will be required to undertake or assist in research and experimental work in connection with one of the following—design of apparatus for radio direction finding; design of apparatus for radio and/or line communications; design of electro-acoustic apparatus.

SCIENTIFIC Officer.—Candidates must hold a first or second class Honours degree in Physics, Mathematics or Electrical Engineering, and have had considerable experience in research or experimental work, either at a University or with a commercial firm.

ASSISTANT II.—Candidates must possess a sound knowledge of the theory of radio communication and should preferably have had training to the standard of a University degree in Physics or Electrical Engineering and be capable of undertaking experimental and design work in radio communication problems.

ASSISTANT III.—Candidates should preferably be under 30 years of age and have had laboratory or works experience in radio engineering and training up to the standard of a University degree in Physics or Electrical Engineering.

ANNUAL Salary Scales, etc.

SCIENTIFIC Officer.—£400 by £18 to £464, and thence by £25 to £680 (efficiency bar at £580).

EXCEPTIONALLY, a commencing salary up to £454 will be given to selected candidates with special qualifications and experience in research or experimental work. The Federated Superannuation System for Universities will apply to this appointment. The Government contributes approximately 10 per cent. of salary and the individual approximately 5 per cent. of salary.

ASSISTANT II.—£315 by £12 to £385.

ASSISTANT III.—£130 by £12 to £310 (efficiency bar at £214). Higher commencing salaries up to £214 may be approved according to qualifications and experience, and in this connection the possession of a University degree will be taken into consideration.

INCREMENTS are Annual and Subject to Satisfactory Service.

PROMOTION to Higher Grades, and in the case of assistant grades appointment to pensionable posts, is governed by suitability and merit as and when vacancies arise.

EX-MEMBERS of H.M. Forces Given Preference, other things being equal.

APPLICATION Forms Obtainable by Post-card from the Under Secretary of State (C.5.), The War Office, London, S.W.1, and to be lodged not later than 10th July, 1939. Quote Appts. 154 (G). [8644]

SERVICE Engineers, full or part-time, required in all districts; test instruments essential; car advantage. —Box 287, c/o The Wireless World. [8635]



At the picnic, our portable set
Quite early, stopped working, and yet
We missed none of the fun
As we might well have done
If we hadn't had FLUXITE, you bet!

See that FLUXITE is always by you—in the house—garage—workshop—wherever speedy soldering is needed. Used for 30 years in Government works and by leading engineers and manufacturers. Of Ironmongers—in tins, 4d., 8d., 1/4 and 2/8. Ask to see the FLUXITE SMALL-SPACE SOLDERING SET—compact but substantial—Complete with full instructions, 7/6. Write for Free Book on the art of "SOFT" SOLDERING—and ask for leaflet on CASE-HARDENING STEEL and TEMPERING TOOLS with FLUXITE.

TO CYCLISTS! Your wheels will NOT keep round and true unless the spokes are tied with fine wire at the cross-ins AND SOLDERED. This makes a much stronger wheel. It's simple—with FLUXITE—but IMPORTANT

THE FLUXITE GUN

is always ready to put Fluxite on the soldering job instantly. A little pressure places the right quantity on the right spot and one charging lasts for ages. Price 1/6 or filled 2/6.



ALL MECHANICS WILL HAVE
FLUXITE
IT SIMPLIFIES ALL SOLDERING
FLUXITE, LTD., Dept. W.W., DRAGON WORKS, BERMONDSEY ST. S.E.1

TO SERVICE MEN



Bargain Offer!!!

A SERVICE KIT FOR 17/6

This Service Kit comprises:

- 4 VOLUME CONTROLS. 20,000, 50,000, 1 meg., 1/2 meg.
- 72 RESISTORS. Assorted, colour coded resistors, 1/2 to 3 watts.
- 2 DOZ. CONDENSERS. Assorted tubular, electrolytic and mica condensers.
- 1 STEEL CABINET. A very useful steel cabinet with partitions for above, screws, etc.

VALUE £4 for 17/6

KIT No. 2 comprising resistors and condensers only, as above 12/6
KIT No. 3 comprising volume controls and cabinet only 6/6

SPECIAL OFFER!!!

Fully shrouded Transformers by America's largest manufacturer. While they last.

All 230 v. primary and fully impregnated.	
T28708—375/375 v. 150 m/A., 6.3V3A. 2.5V6A. 5V3A	15/-
T19610—350/350 v. 150 m/A., 2.5V6A. 2.5V2A. 5V3A	12/6
T7226—375/375 v. 120 m/A., 6.3VCT. 4A. 5V3A	10/6
T7226—350/350 v. 100 m/A., 6.3VCT. 3A. 5V3A	8/6
T7307—350/350 v. 80 m/A., 6.3VCT. 2A. 5V3A	7/6
T7000—320/320 v. 80 m/A., 6.3V4A. 5V3A	7/6
T6025—320/320 v. 80 m/A., 2.5V6A. 5V3A	7/6
T4649D—10V4A Primary Tapped 110-250 v.	5/6
T1113AB—110/230 v. 600 watt Auto Transformer	29/3
The following chokes are interleaved and impregnated.	
T7007—250 m/A., 135 ohms 20-8 Hy., cadmium shrouded	12/6
T7007A—150 m/A., 250 ohms 20-12 Hy., cadmium shrouded	12/6
100 m/A., 20 Hy., 500 ohms, unshrouded	4/11
60 m/A., 15 Hy., 250 ohms	1/11

RADIOMART Telephone: MIDland 3254.
G5NI (Birmingham) Ltd.
44, HOLLOWAY HEAD, BIRMINGHAM



The weekly journal for all who keep Canaries, British Hybrids or Foreign Pet Birds.

W.W.91
Specimen copy of recent issue free on request from The Publisher, Dorset House, Stamford Street, London, S.E.1

SITUATIONS VACANT

SERVICE Engineer Wanted, West London; good mechanic, British, age 30 or over; able take charge; permanency right man.—Box 272, c/o The Wireless World. [8624]

RADIO Gramophone Development Co. Require Chassis Testers and Trouble Shooters; applications should be made in writing or in person to: Globe Works, Newtown Row, Birmingham, 6. [8638]

RADIO.—Production assistant to works manager; good knowledge of production layout and works administration experience.—Apply, by letter preferred, Pilot Radio, Ltd., 31-33, Park Royal Rd., N.W.10. [8621]

YOUTH Over 21 Years, with radio service or similar experience, is required in valve testing department.—Send full particulars of technical training, experience, age and salary required, to Cosmos Mfg. Co., Ltd., Brimsdown, Enfield. [8620]

EXAMINERS and Testers Required in Factory producing radio receivers and transmitters for the services; permanent and interesting work for good men; Croydon District.—Reply, stating age, salary and experience, to Box 246, c/o The Wireless World. [8616]

TELEVISION Time Base Engineer Required; with University degree or equivalent qualification; must have had industrial experience; our own staff know of this advertisement; write in confidence, full details of experience, salary required, and age, to Box 282, c/o The Wireless World. [8639]

DYNATRON Radio, manufacturers of the finest possible radiogramophones, receivers and televisions, require Senior Test Engineer; also service and test engineer; both must have excellent credentials and abilities, personality and drive car; work congenial, permanent, progressive; only first-class men need apply.—Perfecta Works, Ray Lea Rd., Maidenhead. [8637]

ELECTRIC DRY SHAVERS

REMINGTON, Rand, Shavemaster, Packard, Casco, Rabaldo.—Trade enquiries to Leonard Heys, 36, Henry St., Blackpool. [0633]

MISCELLANEOUS

CHEAP Printing.—1,000 billheads, 3/6; sample free.—Creteway Press, 18, Buxted, Sussex. [8180]

G.P.O. Engineering Dept. (No experience required.) Commencing £3/15 per week. Age 12-23. Excellent prospects.—Free details of entrance examination from B.I.E.T. (Dept. 574), 17-19, Stratford Place, London, W.1. [8522]

TRACERS (both sexes) Required Urgently for Drawing Offices.—Those wishing to take up this lucrative work should apply immediately for Free Handbook to B.I.E.T. (Dept. 718), 17-19, Stratford Place, Oxford St., London, W.1. [8568]

EVERY Radio Dealer Who is Not a Regular Reader of "The Wireless and Electrical Trader" should send his trade card at once for a specimen copy and full details of the "Trader" Services. "The Wireless and Electrical Trader" has the widest influence, the largest weekly circulation, and is read by all the leading manufacturers and traders. Trade only, 15/- per annum, post free.—Published at Dorset House, Stamford St., London, S.E.1. [0615]

PATENTS

"PRACTICAL Hints on Patents," free on application.—The Imperial Patent Service, First Avenue House, High Holborn, W.C.1. Preliminary consultation free. [0481]

TUITION

RADIO Training.—P.M.G. exams, and I.E.E. Diploma; prospectus free.—Technical College, Hull. [0611]

PRACTICAL Radio and Television Home Study Courses; booklet free.—I.P.E., 3, Shirley Rd., London, W.4. [8506]

WIRELESS.—Complete training, Marine, Broadcast and Television. Posts waiting. Mod. fees. Boarders taken. Approved college, prosp.—Dept. W., London Radio College, Grove Park Rd., London, W.4. (Chi. 3244.) [0580]

BUSINESSES AND PROPERTY FOR SALE, TO BE LET, OR WANTED

RADIO and Cycle Business in South Birmingham Suburb for Sale, turnover last year £3,500, with certified net profits £327, an extremely attractive business with modern shop and house; offers invited to include H.P. accounts if desired; s.a.v. (about £250).—Shield, Camp and Co., Chartered Accountants, 33, Great Charles St., Birmingham, 3. [8619]

"THE Wireless and Electrical Trader" is an essential part of the equipment of every Wireless Trader; its pages reflect the very latest turn of trade events, and it is read by all the leading dealers and manufacturers, for particulars of businesses offered or wanted. By subscription to the trade only, 15/- per annum, post free.—Send your trade card for specimen copy to Dorset House, Stamford St., London, S.E.1. [0614]

BOOKS, INSTRUCTION, ETC.

AMERICAN Valve Data.—The 200-page Raytheon Data Book gives full characteristics applications, all types American valves; invaluable to servicemen; post free anywhere, 2/3.—Leonard Heys, 36, Henry St., Blackpool. [0594]

ALL Wireless and Radio Engineering Books Available through new financial terms as low as 2/6 monthly.—Write a card or call personally for details and lists from the Radio Department, Phoenix, Chandos Place, W.C.2. [8623]

PREMIER

RADIO

STOCKTAKING SALE

Huge Reduction in Prices of TRIAD U.S.A. VALVES from 2/3 each!

Send for NEW Price List.

Special Offer of ROLA G.12 SPEAKERS

G.12 P.M.'s with Transformer 57/6
 G.12 ENERGISED 1,250 Ω or 2,500 Ω field with Transformer 50/-

All brand new and boxed.

SPECIAL CLEARANCE OFFERS!

TWEETERS. Half Price Offer.

ROTHERMEL-BRUSH de Luxe Piezo Electric Power Tweeters, 6in. diam. Freq. response up to 10,000 c.p.s. Handling capacity 6 watts. List Price, 30/-. Special Half Price Offer, 15/- each.

ROTHERMEL NOISE MASTER, "Anti-Static" Aerial Kit for 12-2,100 metres. Half Price Offer, 17/6 each.

POTENTIOMETERS WITH SWITCH, 1/2 meg., 1/4 meg., 20,000 ohms and 10,000 ohms, 13 each.

POTENTIOMETERS WITHOUT SWITCH, 2 meg., 1 meg., 1/2 meg., 400,000 ohms, 25,000 ohms, 20,000 ohms, 10,000 ohms, 1/- each.

SPECIAL OFFER—CONTINENTAL MAINS VALVES, 4v. AC Types, 5-pin only, AC/HL, AC/L, AC/P, AC/SG, AC/VMS, AC/HP, AC/VHP, 2/6 each.

20v. 18a AC/DC Types, SG. Var. Mu. SG. Power, HF Pen., 2/- each.

U.S.A. Types, 24, 30, 41, 30/44, 35/51, 55, 56, 57, 58, 71, 77, 78, 85, 89, 2A5, 2A6, 2A7, 2B7, 6A7, 12Z3, 210, 250, all 2 for 3/-.

TUBULAR CONDENSERS, .002, .0001, .0003 and .0005 mfd., 1/- doz. Your choice.

ELECTROLYTIC CONDENSERS. Metal Can. 8 mfd. 320 volts, 2 for 1/6. 8 + 8 mf. 475v. + 10 mf. 50v., 2 for 2/6. 8 + 8 mf. 450v. + 8 mf. 250v., 2 for 2/6.

T.C.G. DRY ELECTROLYTICS. 8 + 8 + 4 mf. 500v., 2/- each.

LISSEN Power Packs in aluminium cases, 150 v., 25 m.a., with 6.3 v. L.T., 100-250 v. mains, 10/6, with Rectifier.

MORSE KEYS. Excellent brass movement on bakelite base, 2/9 each. Orders 5/- and over sent Post Free. Under 5/- please add 6d. Postage.

ALL POST ORDERS to: Jubilee Works, 167, Lower Clapton Road, London, E.5. Amherst 4723.
 CALLERS TO: Jubilee Works, or our NEW PREMISES, 169, FLEET STREET, E.C.4. Central 2833.
 or 50, High Street, Clapham, S.W.4. Macculay 2381.

BOOKS, INSTRUCTION, ETC.

"ELEMENTARY Principles of Wireless Telegraphy and Telephony." By R. D. Bangay. Revised by O. F. Brown, B.Sc. Third edition (1930). The standard textbook for wireless students and beginners. Deals with the whole subject of wireless telegraphy and telephony, avoiding too technical a treatment of the problems involved. Well illustrated. Price 7/6 net. By post 8/-, from Illiffe and Sons, Ltd., Dorset House, Stamford St., London, S.E.1.

"THE Wireless World" Diary for 1939 contains 77 pages of facts, formulae and general information of the kind that is always wanted but is difficult to follow. Also a list of the most important European Broadcasting Stations and short-wave stations of the world. Twelve pages of circuit diagrams of receivers, amplifiers and units. —By post 1/7 from Illiffe & Sons, Ltd., Dorset House, Stamford St., London, S.E.1.

"FOUNDATIONS of Wireless." By A. L. M. Sowerby, M.Sc. Second edition. An elementary textbook on receivers. Deals fully with the construction of wireless sets, valves, and the process of detection. Price 4/6 net. By post 4/11, from Illiffe and Sons, Ltd., Dorset House, Stamford Street, London, S.E.1.

"RADIO Data Charts." By R. T. Beatty, M.A., B.E., D.Sc. Second edition. A series of Abacs providing most of the essential data required in receiver design and enabling problems to be solved without having recourse to complicated mathematical formulae. Price 4/6 net. By post 4/10, from Illiffe and Sons, Ltd., Dorset House, Stamford St., London, S.E.1.

INDEX TO ADVERTISEMENTS

	PAGE
Armstrong Manufacturing Co.	3
Automatic Coil Winder Co., Ltd.	2
Barrus, E. P., Ltd.	2
Belling & Lee, Ltd.	Inside Front Cover
Birmingham Radiomart G5N1	6
British Insulated Cables, Ltd.	Inside Front Cover
Edison Swan Electric Co., Ltd.	1
Electradix Radios	7
Fluxite, Ltd.	6
Healey & Baker	4
Institute of Wireless Technology	5
Pamphonic Reproducers, Ltd.	4
Partridge, N.	3
Player's Cigarettes	Inside Front Cover
Premier Supply Stores	2, 7
Rothermel, R. A., & Co., Ltd.	7
Savage, W. Bryan, Ltd.	7
Sound Sales, Ltd.	5
Taylor Electrical Instruments, Ltd.	5
Verdexon, Ltd.	4

RADIO LABORATORY HANDBOOK

By M. G. SCROGGIE, B.Sc., A.M.I.E.E.
 Issued in conjunction with "The Wireless World"

"Radio Laboratory Handbook" gives the serious wireless worker complete information from first-hand experience about laboratory equipment, the instruments which are necessary and the correct methods of operating them.

The fundamental principles are fully discussed, as well as the sources of power and signals, instruments and measurements. Ultra-high-frequency work, the working out of results, and reference data are also dealt with. There is a collection of the most useful symbols, abbreviations, formulae, laws, curves, tables and other data.

A complete index, numbered sections and cross references enable the reader to find what is required without loss of time.

384 pp. 211 illustrations

PRICE 8/6 NET By Post 9/-

From Bookstalls and Booksellers or direct from the Publishers

ILLIFFE & SONS LTD.,
 DORSET HOUSE, STAMFORD ST., LONDON, S.E.1

ELECTRADIX

Rebuilding and Decorating SALE

REDUCED PRICES TO CLEAR

VIBRATOR BATTERY SUPERSEDER with metal rectifier, for H.T. from your 2-volt battery. 3 output volt tappings. Reduced from £3 15s. to sale price 35/-. ALL-WAVE CRYSTAL SETS for plug-in coils, 2 tuning condensers, semi-perm. Detector, 5/6. Why bother to make one for your A.R.P. when cheaper to buy ours?

POCKET HEADPHONES, V.D., all leather headband, strap and cords, 2/6 pair. Wireless type with aluminium headbands, 2/9. 4,000 ohms, 4.6. House, Office and Field Telephones, wall and table, from 10/-. TELEPHONES for House, Office, Garage and A.R.P., cheap. If you are making up your own set buy a Hand Comb. Micro telephone. It will speak over house bell circuits, 7/6.

WIND DYNAMOS: Start generating at 300 revs. up to 2,000 revs., 8/10 amps., ball-bearing, enclosed type, 35/-. LUCAS AERO, 9/12 volts, 250 watt D.C. with enclosed Automatic Cut-out. Used on aircraft for L.T. supply to lighting, heating and wireless. Cost £15. Sale 25/-.

H.T. DUAL, cost £12. 600 volts, 100 m.a. and L.T. 6 volts, 5 amp. Sale, 20/-. PULVO VACUUM DUST EXTRACTORS for works, on trolley, 220 volt, 1-h.p. motor. £5 10s. High Voltage 2 kW motor Gen. 200 v. D.C. to 5,000 v. 400 m.A., £15. 700 watt M.G., 25v. D.C. to 1,400 v., 500 m.A., £5 10s.

SMALL MOTORS. We have nearly a thousand surplus small Motors in almost new condition. 1/100th h.p. to 1/8 h.p. are offered at bargain prices. All voltages.

MOTOR BARGAINS, in midjet lamp. Motor for A.C. or D.C. 200/230 volts, 1/110th h.p. D.O.T. type totally enclosed K.B. Cover, 2,000 revs., at a price never before offered, 7/6 only. Next larger G.M. No. 2 type, high speed, 1/60th h.p., 4,000 revs., 9/6. Larger still 1/40th h.p. Model G.E. No. 1, 12/6.

All as new and first rate for model driving or light duty. EMERGENCY 12-VOLT LIGHTING SETS. "V" Dynamo sets for use with 12-volt battery, 12/16 volts, 10 amps. Enclosed type ball bearings, Vee pulley. Special complete Switchboard for same with ammeter, max.-min. auto cut-out and 1n. Main Switch and Fuses. The set 65/-.

Generator only, 35/-. G.Z. Meter, 7/6. 30 AMP. 1 k.w. Model T.B. Generator, 12 1/2 volts, 45/-. SWITCHGEAR. Battery Auto-Cut-outs. Dix 10 amp. Min., 15/- N.C.S., 30 amp., 35/-. Crawley 100 amp., 45/-. Stud switches, 20 on slate panel, 5/6. FANS, PUMPS and COMPRESSORS cheap.

SIGN LIGHTING. Contact Flasher, G.E.C. 3-circuit motor-driven. Sale price 50/-. Drill Stands. Massive rise and fall rack, 7/6.

METERS. All ranges and sizes in stock. Laboratory precision apparatus, Bridges, Uni-pivots, Galvos., Micro-Ammeters Wavemeters, etc. (See Sale List.)

ELLIOTT 4-Range Testing or Welding Ammeter and Transformer, 400 amps., 100, 25 and 5 amps. with selector switch, 24.

MEGERS as new. Direct Reading .001 ohms to 10 mega. Long scale dial for Resistance measurements, 100, 250 and 500 volts, from 25.

SILVERTOWN Portable Tester. Combined Wheatstone Bridge, Galva, shunts and ratios, as new, £8. G.P.O. Plug-in Bridge Resistance Boxes, to 8,000 ohms, 60/-.

SOLENOIDS, 6-volt for model work or distance switch, core travel 1/4 in. pull 1 oz., 3/6. A.C. Magnets, 230 volts, 30 m/a., 14 oz., 1/2 6.

8 in. DIAL RECORDERS for Draught or L.P. to 12 in. water, 12-hr. clock, 37/6 each.

RELAYS. For front or back of panel, microamps or amps. The small current type for photo cells, radio and remote controls, etc. Low, medium or high res. Prices are low. 5 m.a. Moving Iron, 8/6, 10/6 and 12/6. High Grade Moving Coil, 50 microamps, Weston 60/-; in bronze water-tight case, 70/-.

New model W.L., 50 microamps, 1 1/2 in. panel type, 80/-. MICRO-AMMETERS for Valve Voltmeters, etc., 0 to 50 microamps, full scale, 50 mV. moving coil, 1,000 ohms, flush panel, 2 1/2 in. dial, 2,000 metres. All sizes in stock. 40/- Send for list "W.S."

SPARK COILS. 1/2 in. and 1/4 in. gap, 10/6. Plain ignition coils 6 or 12 v., 3/6. Short wave spark transmitters for boat model control, 17/-. 1,100 Porcelain Ceiling Roses, with Screw Junction Connectors, 2/- dozen.

Meters, Galvos, Bridges, Meggers, Recorders, Lab. Equipment, Chargers, Switchgear, Res. and Instrument Wire, Relays, Motors and Dynamos, Amplifiers and Microphones. Large selection always in stock.

FREE. Our Green Sale List "W." 15 large pages. 100 illustrations of electrical bargains offered by

ELECTRADIX RADIOS

218, UPPER THAMES STREET, LONDON, E.C.4
 Telephone: Central 4611

GET 2 YEARS FREEDOM FROM NEEDLE CHANGING

with the GENUINE Walco Sapphire

GRAMOPHONE NEEDLES

More than 2,000 playings from one needle, a minimum of record wear, and greatly improved reproduction are obtained from the new Walco Needle—price 12/-. Order now or write for FREE BOOKLET "SOUND REPRODUCTION" from

R.A. Rothermel (Dept. G),
 Canterbury Road, High Road, Kilburn, N.W.6

We do quite a lot of business making up transformers to customers' own specifications; but we have a standard list. May we send you a copy?

W. BRYAN
 WESTMORELAND RD. LONDON N.W.9

SAVAGE LTD
 PHONE, COLINDALE 7131

The Yachting World

and Power Craft

The Leading British Yachting Journal

"THE YACHTING WORLD" deals with yachts of all types and tonnages, whether on the sea or inland waters. Every aspect of yachting and motor boating is covered in an attractive and interesting manner.

Every Friday 6^d.

ILLIFFE & SONS Ltd.,
 Dorset House, Stamford St., London, S.E.1 W.W.81

Sixth EditionRevised and Enlarged

HANDBOOK of TECHNICAL INSTRUCTION for WIRELESS TELEGRAPHISTS

by H. M. DOWSETT

(M.I.E.E., F.Inst.P., M.Inst.R.E.)

This standard handbook is planned primarily for the use of wireless operators, whether prospective or actual. It is virtually a complete theoretical course for students wishing to qualify for the Postmaster-General's Certificate of Proficiency.

CONTENTS INCLUDE:

The Electric Charge and the Condenser—The Condenser in Practice—Direct Current and Ohm's Law—Scalar and Vector Quantities and Curve Plotting—Primary Batteries—Accumulators—Magnetism—Electro Magnetism—Self-Induction—Dynamo Electric Machines—Measuring Instruments—Switchboards and Switchgear—Alternating Current Effects, and Vector Diagrams—Alternating Current Fundamental Formulae—Alternating Current Generators, Alternating Current Motors and Transformers—Damped Oscillations—Commercial Types of Spark Transmitter—Aerials and Radiation—Simple Receiver Circuit and Crystal Detector—Thermionics and the Various Applications of the Valve—Depth Sounding—Valve Transmitters—Wavemeter and Transmitter Adjustment—Theory of Valve Receiver Circuits—Valve Receivers—Short Wave Aerials and Apparatus—Marine Direction Finders—Marine Audio Relay Service—Distress Call Apparatus—Lifeboat and Emergency Outfits—Trawler Apparatus—Maintenance of Marine Radio Installations and Possible Faults.

NOW ON SALE PRICE 21/- By post 21/9
Foreign Postage 22/-.

Obtainable from leading booksellers or direct from the Publishers:

ILIFFE & SONS LTD., DORSET HOUSE, STAMFORD STREET, LONDON, S.E.1

The
**Wireless
World**
GREAT CIRCLE
PROJECTION MAP
(ON A ZENITHAL AZIMUTHAL GRATICULE)

GIVING THE TRUE DISTANCE AND DIRECTION
OF EVERY POINT IN THE WORLD FROM LONDON

All short-wave listeners and experimenters will find this map extremely useful for quickly and easily ascertaining the distance and direction of transmitting stations. This information may be read off directly with the help of nothing more elaborate than a foot rule with the inches divided decimally.

The map measures 29" X 34 $\frac{3}{4}$ " and is complete with scales and full explanatory notes.

2/- post free

Published by "THE WIRELESS WORLD,"

ILIFFE & SONS LTD., DORSET HOUSE, STAMFORD ST., LONDON, S.E.1

WW50

Second Edition—

RADIO DATA CHARTS

A SERIES OF ABACS
providing most of the essential
Data required in Receiver Design.

By R. T. BEATTY, M.A., B.E., D.Sc.

Published from the Offices of
"THE WIRELESS WORLD"

"Radio Data Charts" provide designers of wireless apparatus with a ready and convenient means of solving problems without having recourse to complicated formulæ and mathematics.

By the use of "Radio Data Charts" such abstruse problems as the design of tuning coils are solved almost as easily as the simple application of Ohm's Law.

Price 4/6 net By post 4/10

From leading booksellers or direct from the publishers

ILIFFE & SONS LTD.

Dorset House, Stamford Street, London, S.E.1

W.W.93

FOURTH EDITION

Revised and Enlarged with 50 Additional Pages

WIRELESS SERVICING MANUAL

By **W. T. COCKING**
(of "The Wireless World")

The most complete book of reference of its kind. A reliable practical guide for amateur and professional

The present Edition of the "Wireless Servicing Manual" brings the material of the book right up to date and includes an additional chapter on television receivers which is practically the only source of servicing information available on this subject.

Testing apparatus is fully dealt with and the methods of locating and curing faults in receiving equipment are explained.

Ganging, Automatic Volume Control, Instability, Distortion, Mains Hum, Whistles, Local Interference and Aerials, are all separately treated.

The reference material, including base-connections for British, Continental and American Valves, and the various colour codes for components, has been extended and revised.

BOUND IN CLOTH BOARDS

SIZE 7½ ins. x 5 ins.

288 Pages

5/- net. By post 5/5

Issued in conjunction with "THE WIRELESS WORLD" and Published by the Proprietors:—

ILIFFE & SONS LTD., DORSET HOUSE, STAMFORD STREET, LONDON, S.E.1



LEARNING MORSE

AN EASY METHOD OF MASTERING THE INTERNATIONAL SIGNAL CODE

Published from the Offices of **The Wireless World** **6^D NET**
ILIFFE & SONS LTD., Dorset House, Stamford St., London, S.E.1 **BY POST 7d.**
W.W.94

THE WIRELESS ENGINEER

The Journal for Professional Engineers and Advanced Wireless Experimenters

Monthly 2/6 net. Annual Subscription 32/- post free.

ILIFFE & SONS LTD., Dorset House, Stamford St., London, S.E.1

W.W.2.

The ELECTRICAL REVIEW

The Complete Technical Journal

Practical articles on all aspects of electricity supply and utilisation—industrial, commercial and domestic. Latest news of the electrical industry and developments. Advertisement pages form a comprehensive buyers' guide.

Contents of June 30th Issue:—
ELECTRICAL CONTRACTORS AND MINING ELECTRICAL ENGINEERS

Annual Conference Reports.

I. E. E. SUMMER MEETING

AMERICAN EXPORTS

Principal markets for electrical equipment.

NEWS OF THE WEEK

EVERY FRIDAY 6d.

Subscriptions: United Kingdom £1 14s.
Canada £1 12s. Other Countries £2 16s per annum, post free.

ELECTRICAL REVIEW LTD.

Dorset House, Stamford Street, London, S. E. 1

Mention of "The Wireless World," when writing to advertisers, will ensure prompt attention.

DAILY SKETCH

FOR
INSIDE INFORMATION

●
Vividly Presents

- ALL THE NEWS
- BRILLIANT PICTURES
IN ABUNDANCE
- A TEAM OF GREAT WRITERS

BEVERLEY BAXTER, M.P.
CANDIDUS
PAMELA FRANKAU
QUINTIN GILBEY
L. V. MANNING

BEVERLEY NICHOLS
LADY OXFORD
KAY PETRE
SIR HUGH WALPOLE

To be 'in the know' every day more people buy the

DAILY SKETCH

EASY TO READ