

Wireless World

RADIO • ELECTRONICS • ELECTRO-ACOUSTICS

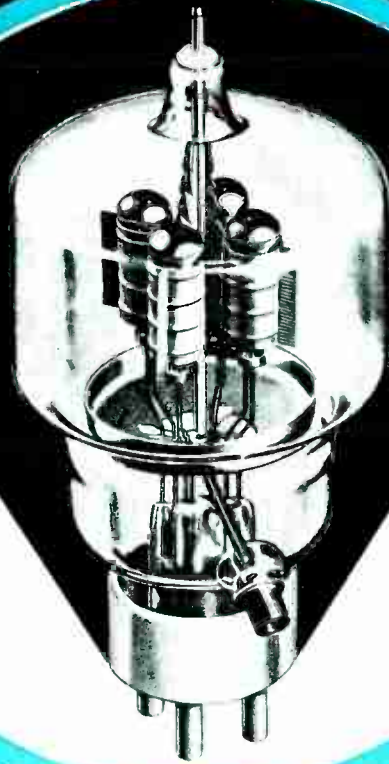

MAR. 1944

1/6

Vol. L. No. 3

IN THIS
ISSUE :

WAVEMETER DESIGN FOR U-H-F

PRIMER ON RUBBER BONDING

NUMBER

3

IN SERIES

FIRST EXAMPLE

As originally planned -

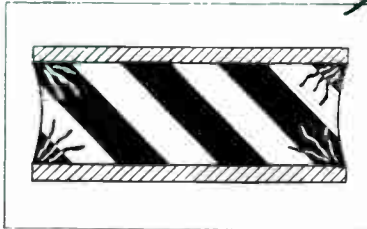

... elementary sandwich, rubber-bonded to flat metal plates having "non-radiused" edges. This leads to severe stress-concentrations at junction of rubber and metal.

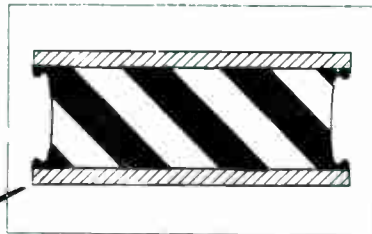

As modified

... bonded edge of metal plates covered by stress-reducing "beads," prevents load-carrying volume of rubber from failing at edges.

SECOND EXAMPLE

As submitted to us -

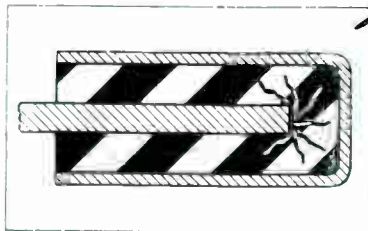

... centre metal part bonded end-on into rubber bulk. Stress-concentrations caused by movement of enclosed metal edges.

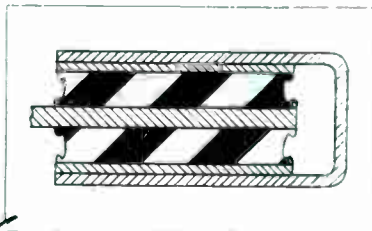

As modified

... stress-concentrations avoided by modification to moulding-in of centre metal part and by profuse use of stress-reducing "beads."



RUBBER BONDERS LTD.

ENGINEERS IN RUBBER BONDED TO METAL
FLEXILANT WORKS · DUNSTABLE · BEDS.



MODEL 7
UNIVERSAL
AVOMETER

AVO

REGD. TRADE MARK

On Active Service



"AVO" Electrical Testing Instruments are maintaining on active service and in industry the "AVO" reputation for precision and reliability. Orders can only be accepted which bear a Government Contract Number and Priority Rating.



Regd. Trade Mark

MEANS
ACCURACY

Sole Proprietors and Manufacturers

THE AUTOMATIC COIL WINDER & ELECTRICAL EQUIPMENT CO., LTD., Winder House, Douglas St., London, S.W.1

Telephone: Victoria 3404/7



the amateur is still in radio

No other industry has had the benefit of such an eager and proficient group of supporters as the radio amateur.

By his own experimentations and inventions, and because of the extreme demands he made upon radio equipment, the radio amateur has been the driving force behind many of the major developments in radio. Out of the amateur testing grounds have come advanced techniques and vastly superior equipment of which Eimac valves are an outstanding example.

Eimac valves created and developed with the help of radio amateurs, possess superior performance characteristics and great stamina. They will stand momentary overloads of as much as 600% and they are unconditionally guaranteed against premature failure due to gas released internally. These are good reasons why Eimac valves are first choice among leading electronic engineers throughout the world.

Follow the leaders to

Eimac
THE U. S. PAT. VAL.
VALVES

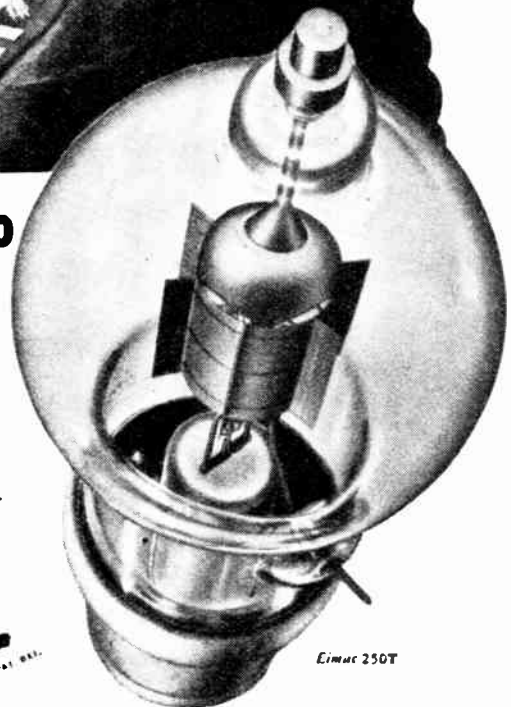

Eimac 250T

Eitel-McCullough, Inc., San Bruno, California Plants located at San Bruno, California and Salt Lake City, Utah

754

Export Agents: Frazar & Hansen, 301 Clay Street, San Francisco, California, U. S. A.

Service Engineers

repairing domestic radio may now use

ERSIN MULTICORE SOLDER

THE SOLDER WIRE WITH 3 CORES OF NON-CORROSIVE ERSIN FLUX

Ersin Multicore — the A.I.D. approved solder wire containing three cores of active non-corrosive Ersin flux, has been adopted by the leading makers of radio and electrical appar-

atus in preference to other forms of solder because it provides speedy and efficient soldering with complete immunity from corrosive or dry joints.

Because of the economy of metals effected in using Ersin Multicore and the fact that the repair of domestic radio is now rated as an "Essential Home Civil Requirement," Service Engineers, too, can now enjoy the advantages of the finest cored solder in the world.

Stocked by the leading radio and electric factors. There may be slight delays in delivery, but insist on Multicore, and you will receive your share in turn. In case of extreme difficulty write to Multicore Solders Ltd., giving name and address of usual factor. Firms engaged upon Government Contracts are invited to write for free technical information and samples.



13 GAUGE - 4/10
 16 GAUGE - 5/3
 above prices subject to usual trade discount

MULTICORE SOLDERS LTD. COMMONWEALTH HOUSE, NEW OXFORD ST., LONDON, W.C.1. Tel. CHAncery 5171/2

WHAT IS MEASUREMENT?

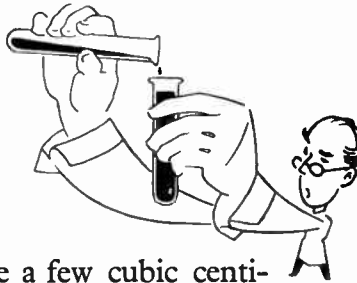

You can see a few cubic centimetres, but you can't see the current in an electric circuit! True, but you can *measure* it.

FOR ACCURATE MEASUREMENT USE ACCURATE INSTRUMENTS



M.I.P. Instruments have been tried and tested under exacting conditions all over the world. Their fine workmanship and unfaltering service have made them standard equipment in Electrical Measuring Instruments wherever accuracy and precision are of first importance.

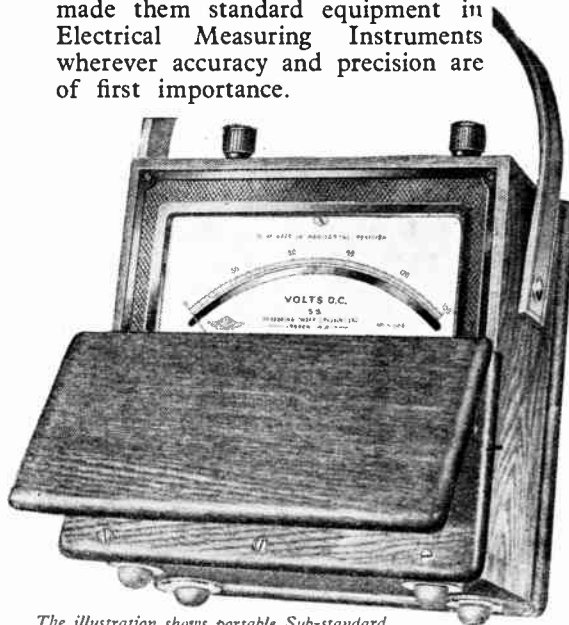

The illustration shows portable Sub-standard Moving Coil Voltmeter.

MEASURING INSTRUMENTS (PULLIN) LTD.,

Electrin Works, Winchester Street, Acton, W.3.

WHARFEDALE

GOLDEN CHASSIS

Basically unchanged since 1935 . . . and still in the forefront to-day!

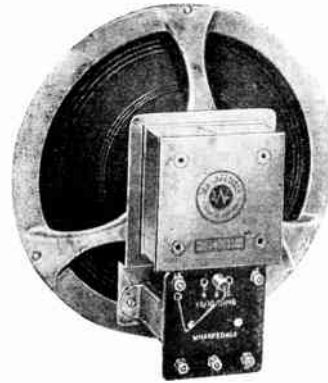

The Response Curve here shown was taken nearly 7 years ago and it has been found impossible to improve on it by any change in the Cone. Improvements to the suspension have brought the Cone Resonance down to below 75 C.P.S. Used by B.B.C., G.P.O., etc.

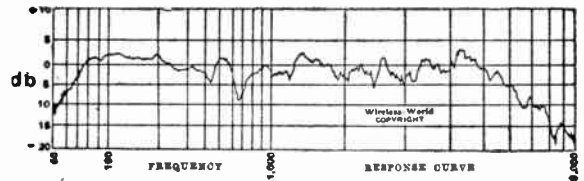

PRICE 70/- (without Transformer). PRIORITY ORDERS ONLY
WHARFEDALE WIRELESS WORKS
HUTCHINSON LANE, BRIGHOUSE, YORKS.

★ CABINETS ★

When Victory rings down the curtain on War, we shall again be able to provide you with cabinets of tasteful design.

F. W. EDWARDS, LIMITED.
18, NORMANS BUILDING'S CENTRAL ST LONDON E.C1. Clerk 7460.

WALTER CONDENSERS ARE MADE FOR

WALTER INSTRUMENTS, LTD.

Earls Court Exhibition Buildings, Earls Court, London, S.W. 5
FULHAM 6192

C. R. Casson 7a



**T H E R E I S N O S U B S T I T U T E
F O R
E N G I N E E R I N G E X P E R I E N C E**

*

And this is obviously a matter of extent, intensity and time.

Take Electrical condensers for instance—simple in conception maybe—but demanding infinite experience and skill, to satisfy the exacting operating conditions of modern requirements. The fulfilment of these has meant the whole time occupation of highly skilled specialists, working at high pressure, in this way to earn, along with their countrymen in other spheres, the right of survival.

What a wealth of experience and technical excellence will be available to all, when happier times arrive ; and nowhere more than in Dubilier Condensers.

DUBILIER
CONDENSER CO. (1925) LTD.





*Clear as a
Crystal*

AND HERE IS THE REASON . .

. . . the answer has been found in Bullers Low Loss Ceramics to the problem of Dielectric Loss in High Frequency circuits.

Years of Laboratory research and development have brought these materials to a high degree of efficiency. To-day they are in constant use for transmission and reception, and play a vital part in maintaining communications under all conditions.



**Made in
Three
Principal
Materials**

FREQUELEX

An Insulating material of Low Dielectric Loss, for Coil Formers, Aerial Insulators, Valve Holders, etc.

PERMALEX

A High Permittivity Material. For the construction of Condensers of the smallest possible dimensions.

TEMPLEX

A Condenser material of medium permittivity. For the construction of Condensers having a constant capacity at all temperatures.

BULLERS, LTD.
THE HALL,
OATLANDS DRIVE,
WEYBRIDGE, SURREY
Telephone :
Walton-on-Thames 2451
Manchester Office :
196 Deansgate, Manchester.

Bullers

LOW LOSS CERAMICS

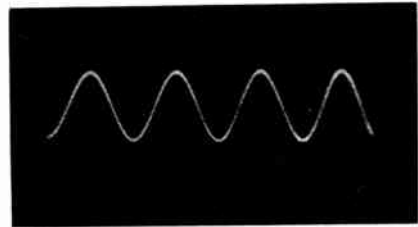

B.S.R. STANDARD SINE WAVE SOURCES

TYPE LO.800A. OSCILLATOR

—an actual oscillogram of output voltage is illustrated—gives good waveform even below 10 c.p.s. This necessitates a minimum "pull-in" between the two H.F. oscillators. Superlative design results in an almost perfect waveform from the lowest to highest frequencies. The output voltage is constant to within a few per cent. over the frequency range. This Model is chosen as a Standard by most Departments. Stable, reliable. Indispensable to all serious workers.

Output up to 5 watts. Three range output voltmeter incorporated—0-250, 0-50, 0-10. Four output impedances, 5000, 1000, 600 and 15 ohms. Frequency ranges (3 models), 0-15000, 0-25000 and 0-50000 c.p.s.



**BIRMINGHAM SOUND
REPRODUCERS LTD.,**
Claremont Works, Old Hill, Staffs.
Cradley Heath 6212/3. Grams: Electronic, Old Hill

*When they have
finished their
vital war service*



DAGENITE

AND

PERTRIX

*—the dependable BATTERIES
will again be available
to all*

FOR RADIO, CARS, MOTOR
CYCLES, COMMERCIAL VEHICLES, AIRCRAFT, ETC

Sales Concessionaires: **HOLSUN BATTERIES LTD.**
137 Victoria Street, London, S.W.1.

D106.

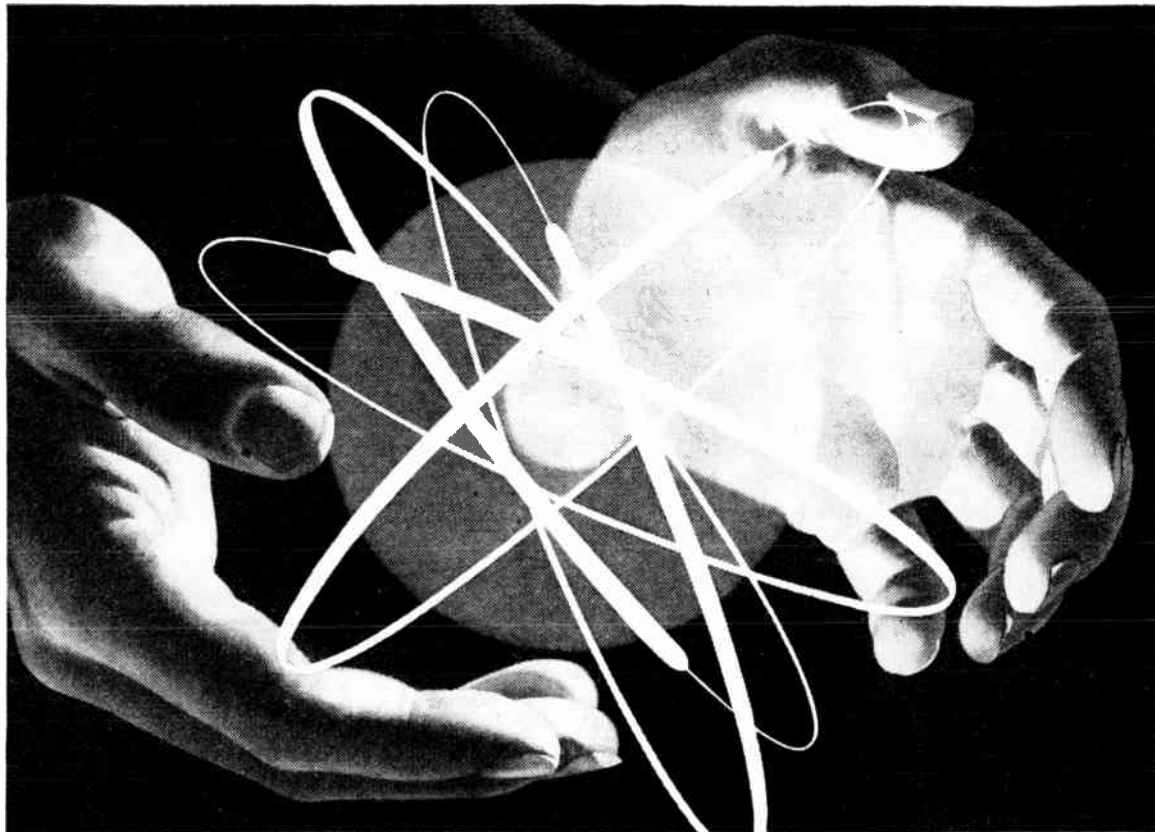

THIS IS MAGIC 1944

Through thick fog a plane flies safely to its base; makes a perfect landing. In a factory a wisp of smoke appears and an automatic-warning sounds the fire-alarm almost before the fire is started. A new machine records the thought-impulses of the brain. X-rays reveal the ills of human tissues, the flaws of massive metal castings—All this is the magic of electronics—the science of the electron.

Born only at the beginning of the century, this wonder-science now speeds

our industry, contributes to our safety, combats disease, probes the mysteries of the universe—And, already established as a landmark in the short history of electronics, Mazda Valves and the organisation behind them journey on towards an era of new and dazzling progress — The Electronic Era.

MAZDA valves

FOR INDUSTRIAL, MEDICAL, RADIO,
SCIENTIFIC AND DOMESTIC APPLICATIONS

THE EDISON SWAN ELECTRIC CO. LTD.,  155, CHARING CROSS RD., LONDON, W.C.2.

*In all communications-
Condensers are at work*



TRADE **HUNTS** MARK
The
Home of Condensers

ADVT. of A. H. HUNT LTD., LONDON, S.W.18. EST. 1901

M.R. SUPPLIES

maintaining their reputation for instant delivery and dependable quality, offer the following brand new RADIO, ELECTRICAL and INDUSTRIAL EQUIPMENT. All prices nett cash.

MINIATURE P.M. M COIL MICROPHONE SPEAKER UNITS. These 3-inch units are fitted with an exceptionally heavy alnico magnet giving first-class reproduction both as speaker or mike. Imped. 12-ohms. Ideal for P.A., calling systems, etc., and for ext. speaker, portables, etc. 30/-.

ROTHERMEL-BRUSH PIEZO-CRYSTAL MICROPHONES. Neatly housed in black bakelite, 2 1/2 in. dia., with plated mounting boss tapped standard 1/4 in. fitted with 6ft. screened lead. Level response and high output, and confidently recommended for all microphone uses. Take advantage of this exceptional opportunity—only 42/- each. Suitable Table Stands, chrom., extending, 25/-. Floor Stands, chrom., portable, with "easy-mount" adaptor, 45/6.

G.E.C. CURRENT-FED MICROPHONES. Require no amplifier—work directly from 12-volt accumulator (current drain when in use only 14 amp.). Supplied with appropriate transformer for matching to 15-ohms coil—4x terminals:—mike, battery, speaker. The microphone has a return switch at convenient point above handle to be pressed while speaking, thus conserving battery consumption. Complete, 29/17 6. NOTE.—Any 15-ohms speaker will suit, but we can supply from stock the most efficient type with P.M. Projector Unit (15-ohms) and 30-inch Dispersive Horn, price 28/17 6. The complete system as above supplied for £18 10/0 (Carr. 7/8). We have only 30 complete systems.

G.E.C. PUBLIC ADDRESS SPEAKERS (Projector type). Latest 10-watt P.M. M(Coil Proj. Unit (15-ohms Imp.) with built-in multi-line transformer, and 42-inch round All-Metal Horn. Greatest projection power and intelligibility. £10 5/0 complete. (Carr. 7/6).

ELECTRODE WIRE JOINTERS ("Fuzit" by S.T.C.). Suitable for all S.W.G. from 50 to 30. Place twisted ends in jaws of tool-press and release trigger. Instantaneous and perfect wire jointing. Complete with well-housed portable Transformer (200 250 v.) and all leads, 25 nett (Pkg. Carr. 3/6). Govt. No. must be quoted for this item.

SLIDING RESISTANCES. 100 watts, fully enclosed, 4 1/2 in. long with bushed cable entries. Laminated brushes giving smooth, positive action. Full range a.s.u. available:—4 ohms 5 amps., 10 ohms 3 amps., 50 ohms 1.4 amps., 100 ohms 1 amp., 200 ohms 0.7 amp. and 400 ohms 0.6 amp. Any one 25/-.

"PYROBIT" ELECTRIC SOLDERING IRONS. The popular "instrument" model for small electrical work—can be held like a pencil. Only 9 1/2 in. long with efficient radiation for hand comfort. Voltage 230/250, watts 45 (bit temperature over 300 deg. C.). Supplied with pointed pencil bit, 21/-. Extra adjustable angle bit, if required, 4/3. Resin-coated SOLDER (S.T.C.) 40 per cent. tin, on 1 lb. reels, 4/9.

"PYROBIT" NEON TESTERS (New Safety model) with Screwdriver. 100, 750 volts A.C./D.C. 9/6.

TRANSFORMER BOBBINS. Solving the rewind problem. Standard for many sets, H.M.V., Marconi, Pye, Lissen, etc. Prim. tapped 200 250 v. Secs. 1—350 0 350 v. 75 ma., 4 v. 3a., 4 v. 4 a., core opening 1 1/2 in. sq. and 1 1/2 in. through, 18/6. Also with 6.3 v. 4a. and 5 v. 3a., same price.

LONDEX RELAYS. 6-volt D.C. coil, 2-pole break (3 amps. at 230 v.), 7/6.

ERICSSON HEADPHONES, 2,000 ohms with adjustable headbands, 25/- pair.

TOGGLE PRESSES (S.T.C.). Still available from stock—see previous advertisements. Please include sufficient for packing postage.

(Telephone MUSeum 2958.)

M.R. SUPPLIES, 68, New Oxford Street, London, W.C.1.

(Telephone: MUSeum 2958)

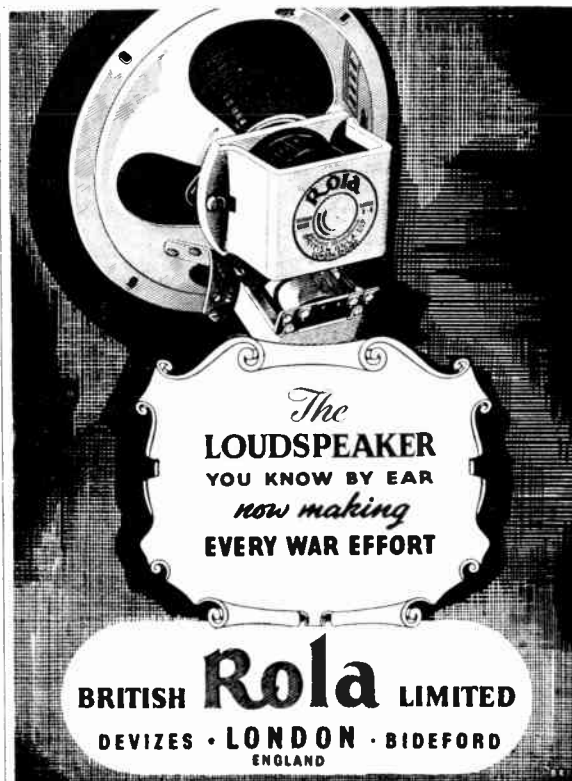

The
LOUDSPEAKER
YOU KNOW BY EAR
now making
EVERY WAR EFFORT

BRITISH Rola LIMITED
DEVIZES · LONDON · BIDEFORD
ENGLAND

SPECIAL CABINET OFFER



No. 1

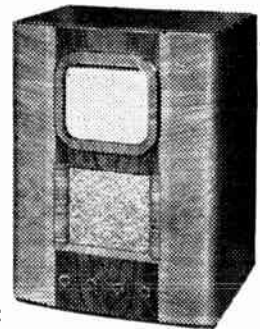

No. 2

No. 1. Exceptionally well-made pre-war cabinets figured and inlaid walnut, ex television, large enough for radio chassis, loudspeaker and power pack. Dimensions: 20" x 17" x 16" **4 Gns.**

No. 2. As above, dimensions: 22" x 17" x 16" **£4.12.6**

No. 3. DE LUXE Console Model, specification as above, dimensions: 38" x 19" x 16" **8 Gns.**

SEE ILLUSTRATIONS.

Packing case for all above, 10/- extra.

MULLARD & MAZDA CATHODE RAY TUBES

7 in. **£3 10 0** 9 in. **£4 18 0**

HOLDER, for above, complete with mounting base, scanning and focussing unit with coil **47/6**
HIGH VOLTAGE TRANSFORMER, for above, **47/6**
 200/250 v., 4,000 v., 2 v. 2 amp.

Line scanning output transformer **12/6**

.1 T.O.C. 4,000 v.w. Condensers for above, Brand new **8/6**

RECTIFIERS FOR ABOVE, UU4 at 11/-; U21 at 18/3
 Plywood frame and rubber foot for Cathode Ray Tube, also suitable for loudspeaker baffle, 7 in. hole **7/6**

VALVE HOLDERS—AMPHENOL TYPE. International or Mazda Octal, chassis mounting, 1/-.

TUBULAR STEEL FRAMES. Cadmium plated for radio chassis mounting and many other purposes, drilled ready for use—14 in. high x 14 in. wide, very useful for swivel frame in Radio Laboratory. 7/6 the pair.

SUPERIOR QUALITY KNOBS, ex television, suitable for radio. For 1/4 in. spindles with grub screw. 1 1/2 in., 1/8; 1 in., 1/3; 3/4 in., 9d.

TUBULAR PAPER CONDENSERS. 350-500v., D.C. working, .0001, .0003 mfd., 4/- doz.; .001, .004 mfd., 6/- doz.; .01 mfd., 7/- doz.; .05 mfd., 9/- doz.; .1 mfd., 12/- doz.; .25, .5 mfd., 15/- doz., or assorted parcel of 50 for 27/6. Minimum orders, 1 doz. any type.

SILVER MICA CONDENSERS. Flat wire-ended. Assorted values, 17/6 per 100 (not more than 5 alike).

RADIO CHASSIS, 18-gauge steel, cellulosed grey, fitted 4 octal valve holders, grommets, with 20 colour coded resistors. Dimensions: 11 x 7 1/2 x 1 1/2. 15/-
 Also similar but fitted mains socket and three 4-pin valveholders, grommets, drilled ready to take transformers, chokes, etc. Dimensions: 14 x 10 1/2 x 1 1/2. 17/6.

HUMDINGERS. 25,000 and 50,000 ohms, 6d. each.

CALLERS to Show Rooms,
61 HIGHGATE HIGH ST., N.6
 Phone: MOUtvint 9432

SCREENED INTERLACED FLEXIBLE MICROPHONE CABLE. Single. Special Offer, 9d. per yd. Pre-war Super Quality, 1/3 per yd. Twin, 1/3 per yd.

MICROPHONES. De Luxe Piezo-Crystal microphones in chromium case. Specification: 60 D.B. below 1 volt. Frequency response 30/8,000 C.P.S., 6 Gns.

As above—Standard Model in bakelite case, 3 Gns. 2-tier Stands for above, 25/-.

ALUMINIUM VALVE CAPS. Special price 6d.

SCREENED MICROPHONE LEAD, fitted four Wander Plugs, 3/6.

6 ASSORTED VOLUME AND TONE CONTROLS with and without switch, 19/6.

L.F. SMOOTHING CHOKES. Finest quality, 20, 40 and 60 henries, 150 m.a., 16/9 each.

SWITCHES. DPDT panel mounting, P.O. type. 2/8. D.P. 4-point pushpull, 9d.

LINAGLOW LIMITED

We have **THE GOODS**
 but insufficient space
 to advertise them all—
So send us your requirements

HOURS OF BUSINESS 9 a.m. to 5.30 p.m.
Saturday, 9.30 a.m. to 12.30 p.m.

LOUDSPEAKER TRANSFORMERS. Pushpull output tapped Primary and Secondary; 120 m.a. ratios 10:1, 5:1 and 3.5:1. 15/- a Multi-Ratio and Push-Pull transformer, ratios 30:1, 45:1, 60:1, 90:1 and P.P. class B, 75 m.a., 12/6. Heavy duty multi-ratio transformer, ratios 24:1, 41:1, 48:1, 68:1, 82:1, 116:1, 80 m.a., 15/6.

MAINS TRANSFORMERS. 200/250, 350-0-350, 6.3v. 3 amp., 5v. 2 amp. 120 m.a. shrouded, 42/6; 300-0-300, 4v. 6 amp., 4v. 2 amp., 150 m.a., 42/-; 325-0-325, 4v. 6 amp., 4v. 2 amp., 2 v. 1.5 amp., 150 m.a., 45/-.

AUTO TRANSFORMERS. Step up or down, 110 220/240 v., 100-watt, 35/-; 110/240 v., 75 watt, 27/6.

LOUDSPEAKERS. P.M. 3 ohm voice coil without transformer, 5 in., 21/-; 6 in., 22/6; 8 in., 25/6; 10 in., 28/6. 10 in. Mains Energised M.C. Speaker, 2,000 ohm field, 2.5 ohm speech coil, 32/6.

SPECIAL HEAVY DUTY RESISTORS. 5-watt for bias, etc., all values from 25 to 2,000 ohm, 1/9 each. Similar to above, but 10-watt, 2/3.

50-OHM CENTRE-TAPPED RESISTOR, tapped at 25 ohm, for pilot lamps, 2/-.

SPECIAL MULTI-LINE CORD RESISTOR. 5 tappings, 50 ohm, 1 tapping 750 ohm, with slider, 2 amp., 8/6. 950 ohm 2 amp., Chassis mounting, heavy duty on porcelain former, 2 adjustable tappings, 8/6 each.

UNIVERSAL RESISTOR. Suitable for practically every type of American and British AC/DC Receiver, supplied in safety cage with asbestos lining. Specification: 750 ohms 3 amp., with four sliders for adjustable tappings, 12/6.

VALVES

AMERICAN TYPES AT B.O.T. CONTROLLED RETAIL PRICES. FOR REPLACEMENT PURPOSES ONLY.

1H5, 12F5, 128F5, 9/2; 1A5, 1C5, 5Y3, 6X5, 25Z6, 35Z4, 35Z5, 11/-; 6Q7, 12Q7, 128Q7, 11/7; 6P6, 6K7, 12SK7, 50L6, 25L6, 12J7, 35L6, 42, 78, 12/10; 6A4, 6B8, 6K8, 68A7, 128A7, 14/-; 70L7, 83, 15/3. Also British Valves at Manufacturers' List Prices. AC/ME, 10/8; UU4, U6, U7, 11/-; HL41DD, TDD4, 11/7; AC/VP2, CL4, EF39, KTW61, Pen 45, SP41, 8P45, T41, VP41, 12/10; D1 Diode 1in. Peanut Valve with valve holder, 12/10; ECH3, FC13, X63, X65, 14/-; AC6Pen* EL35, Pen 46*, U21, 18/3.

*Post Office Permit Necessary.
 All prices include P.T. Add 3d. per valve postage.

UNIVERSAL RAZOR RESISTANCE. Suitable for practically every type of electric Razor, drops voltage from 200-250 to 100-110v. Supplied in safety metal case with asbestos lining. Specification: 1,500 ohms with adjustable slider, 10/6.

LINE CORDS. 2-way 360 ohms, 8/6; 480 ohms, 11/-; 600 ohms, 13/9; 3-way heavy duty 3 amp., 360 ohms, 13/6; 480 ohms, 17/8; 600 ohms, 21/-.
3in. Goodman P.M. LOUDSPEAKER. Extra heavy magnet for Midgets and communication sets, 30/-.

POST ORDERS to Dept. M.O.12
3 HAMPSTEAD LANE, N.6.
CASH WITH ORDER ONLY

VOLUME CONTROLS. 1,000, 5,000, 10,000, 20,000, 25,000, 50,000, 100,000-ohm; 1, 1/2 and 2 megohm without switch, 4/9 each. As above with switch 6/9. 1/2 megohm Double Pole Switch, Best American, 7/6. **WIRE WOUND**, best American, New ex television, 2,000 and 10,000 ohms, 5/- each.

WIRE-ENDED CARBON RESISTORS. New, ex television chassis, 1, 1/2, 1 and 2-watt. Assorted parcel of 100 35/-.

5-v. A.C. ALL-WAVE SUPERHET CHASSIS

Complete with valves and 8 in. Energised M.C. speaker. Provision for Extension loudspeaker and pick-up.



£15.10.0

Including P.T.
 Packing Case, 10/- extra.



No. 3

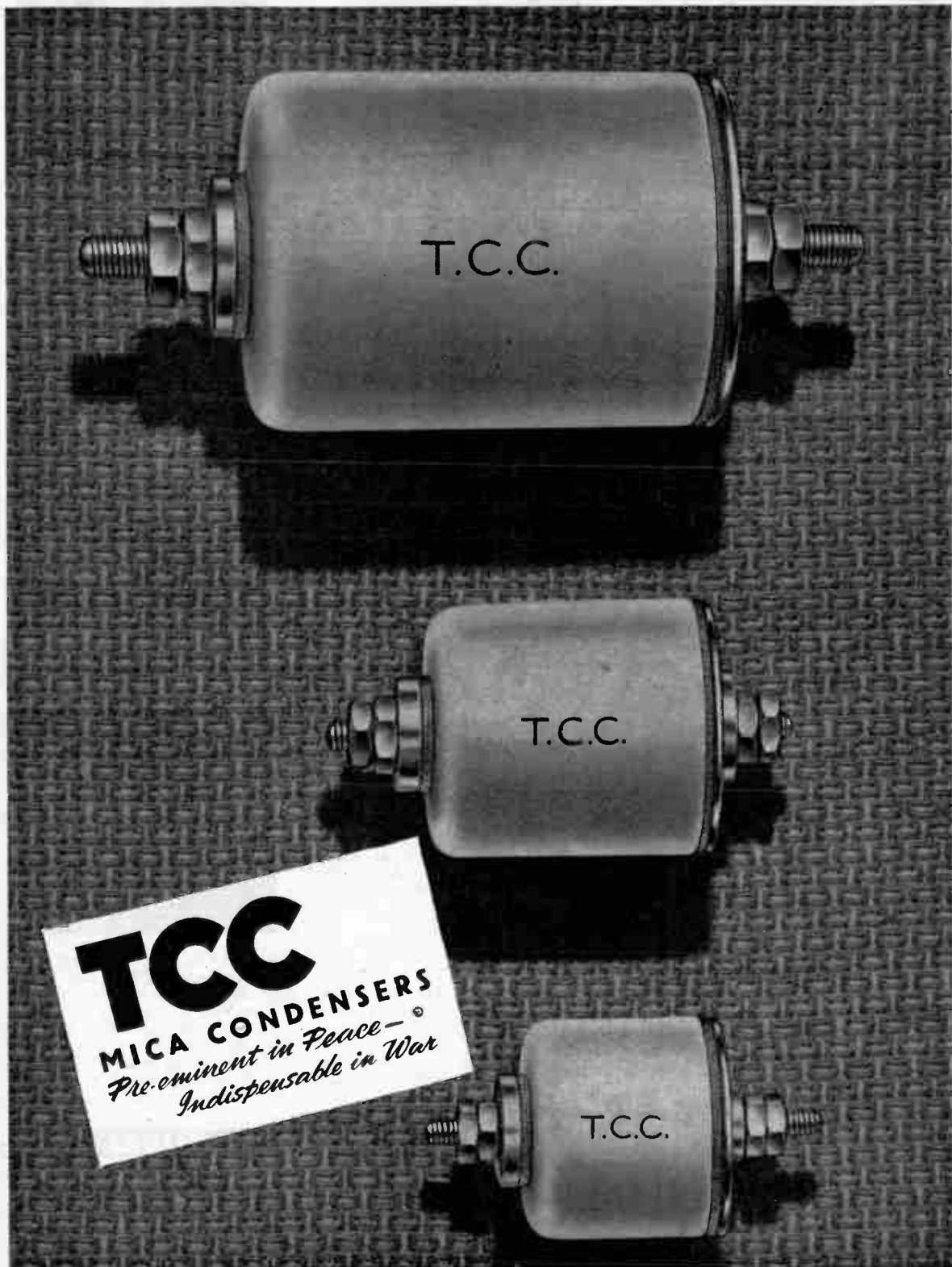

TCC
MICA CONDENSERS
Pre-eminent in Peace—[®]
Indispensable in War

ADVERTISEMENT OF THE TELEGRAPH CONDENSER CO., LTD.



GOODMANS
New **T 2-12"**
LOUDSPEAKER

for the SERVICES
and all PUBLIC ADDRESS PURPOSES
including FACTORIES, WORKSHOPS,
 CANTEENS, ETC.

Goodmans
 LOUDSPEAKER & TELEPHONE ENGINEERS

INDUSTRIES, LTD.
 WEMBLEY, MDX.



Most people have learned not to trust the eye against the hand. You can't trust the eye alone in judging P.A. Equipment, either. Actual performance is the only dependable guide . . . still another reason why R·S Equipment is in such heavy demand in sterner fields that the range generally available is very, very small. If, however, you would like your customers to know just what R·S Equipment can still be supplied, a penny stamp will bring you our most recent catalogue.

R·S
AMPLIFIERS

R. S. Amplifiers, Ltd., 3-4, Highfield Road, Shepperton, Middx.
 Telephone: Walton-on-Thames 1019.

ROGERS

Postwar industry will be making wider use of industrial electronic technique developed during recent years. In this

work Rogers Radio Tubes—the tubes which opened the way to all-mains wireless—have played and will play a recognised part. Rogers with an established reputation for quality, produce all standard types of radio receiving tubes, power tubes for radio transmission, audio frequency amplification and industrial electronic applications generally. At present engaged solely on official work, they look forward to future co-operation over a wide field of industry.

ROGERS RADIO TUBES LTD.

TORONTO (ONTARIO) CANADA

A subsidiary of BROADCAST RELAY SERVICE LIMITED,
 VICTORIA STATION HOUSE, VICTORIA ST, LONDON, S.W.1.

EDDYSTONE

Interchangeable coil units versus *Switched Coils*

The Eddystone designers have eliminated switch contact trouble and dead-end effect by the use of separate coil units, ensuring the utmost reliability. In addition the frequency range can be considerably extended. In place of the commonly used range of, approximately, 26,000 to 600 Kc/s., the 358X covers all frequencies from

31,000 to 40 Kc/s.

Complete technical details, including all circuit values, in 30-page Instructional Booklet on "358X." Price 2/6 post free.

358X



WEBB'S

Radio

14, SOHO ST. LONDON. W. 1. 'Phone: GERrard 2089

THE RECEIVER MAY BE INSPECTED between 9 a.m. and 4 p.m. (Saturdays 9 a.m. to 12 noon).

★ IN THE DEVELOPMENT AND MANUFACTURE OF

Radio Frequency CABLES

B.I. HAVE PLAYED A LEADING PART

★ . . . and though supplies are directed to the Services, the experience gained over a considerable manufacturing period is available for the benefit of approved users.

Note.—From fundamental principles, B.I. have made outstanding contributions to design and construction of cables for radio frequency transmission and have perfected production technique.

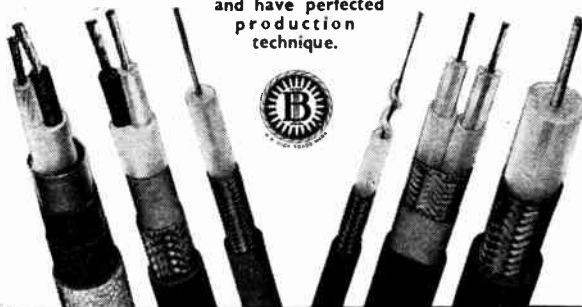

© BRITISH INSULATED CABLES LTD. PRESCOT, LANCS.

L.T. UNITS in "WESTALITE"

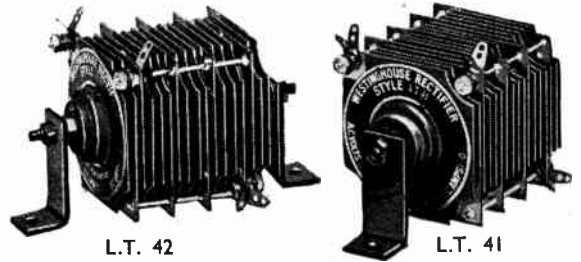

L.T. 42

L.T. 41

TYPE	OUTPUT	
	VOLTS	AMPS
L.T. 41	12	1
L.T. 42	6	1
L.T. 44	12	2
L.T. 45	6	4

This range covers small rectifiers for charging batteries up to 6 lead acid cells, or supplying small resistance loads.



METAL RECTIFIERS

WESTINGHOUSE BRAKE & SIGNAL CO., LTD.,
Pew Hill House, Chippenham, Wilts.

CELESTION

VALVEHOLDERS

Manufactured under "Amphenol" Licence.

The name "Celestion" is a guarantee of quality & service.

List of British and American types will be sent on request.

At present we can only supply against Priority Orders.

CELESTION LTD.
Engineers
KINGSTON-UPON-THAMES, SURREY.
Telephone: Kingston 5656-7-8

HIVAC

THE SCIENTIFIC VALVE

BRITISH MADE

Specialists in

MIDGET VALVES

HIVAC LIMITED
Greenhill Crescent,
Harrow on the Hill, Middx.

Telephone: Harrow 0895.

*A midget
in size
but a
giant in
performance*

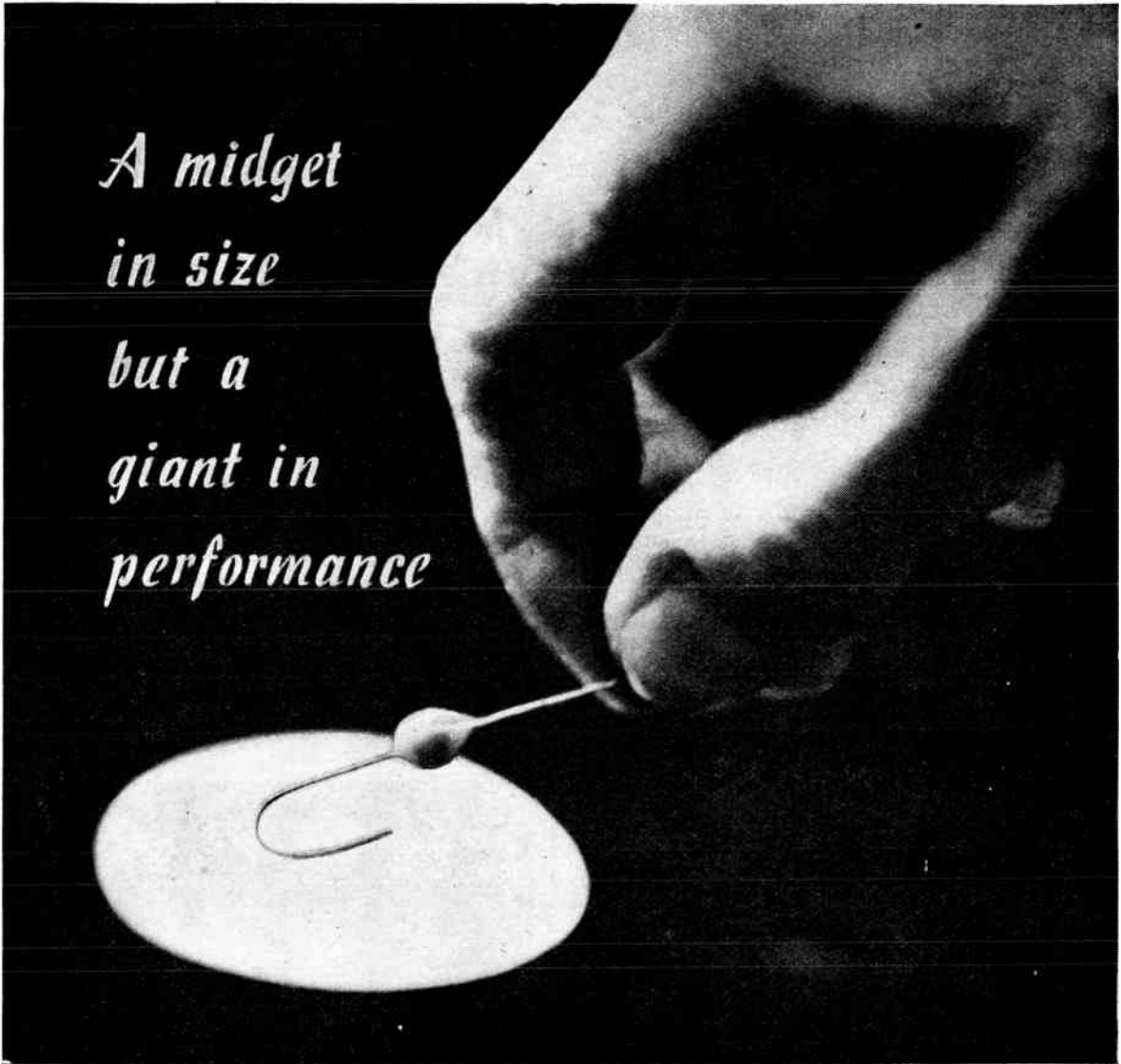

A mighty important little fellow for maintaining vital radio communications is this U.I.C. Pearl Type Ceramic Condenser.

Diameter 7 mm. max. Length 9 mm. max. Capacity range 0.5pF—5pF. Capacity Tolerance pl/mn 20%. Test Voltage 1500v D.C.

Suitable for tropical and arctic conditions.

UNITED INSULATOR CO. LTD.
12/22, LAYSTALL STREET, LONDON, E.C.1

Tel.: TERminus 7383 (5 lines)

Grams.: Calanel, Smith, London



CERAMIC
PEARL TYPE
CONDENSERS
TYPE APPROVED

THE PIONEERS OF LOW LOSS CERAMICS

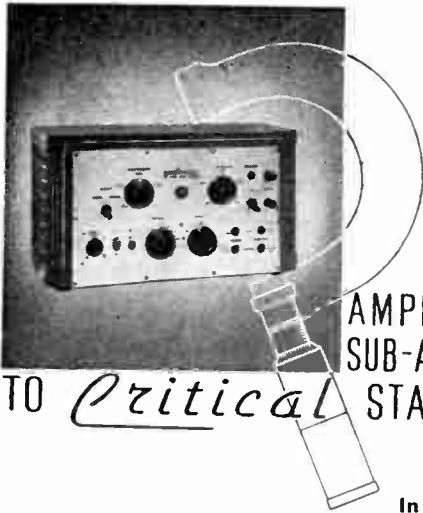

AUDIO AMPLIFIERS & SUB-ASSEMBLIES TO *Critical* STANDARDS

In addition to Standard Amplifiers the activities of Acoustical include Special Amplifiers for Industrial Applications, Microphones, Transformers, Coil Winding, Sheet Metal Work, Stampings, Switch Assemblies, etc.

ACOUSTICAL MANUFACTURING Co. LTD.
HUNTINGDON - TEL: 361

TAYLOR ALL WAVE SIGNAL GENERATOR MODEL 65A

We also manufacture:—
Model 83A.—74 Range Universal Taylormeter. 4,000 ohms per volt A.C. and D.C. Price £15 15s. 0d. complete.
Model 45A S. Mutual Conductance Valve Tester. Covers all popular British, American and Continental Valves. A.C. Mains operated. Price £15 15s. 0d.
Model 47A S.—Mutual Conductance Valve Tester combined with Multirange Universal Meter. A. C. Mains operated. Price £18 18s. 0d.

This new, improved generator operates from A.C. Mains and covers a range from 100 Kilocycles to 46 Megacycles in 6 wavebands, the dial being directly calibrated in frequency. Output smoothly variable up to approximately 100,000 Microvolts. Either external or internal modulation at 400 Cycles can be used. Iron cored coils used on all bands. The instrument is thoroughly screened, and mains filter is fitted, reducing radiation to minimum. Screened output lead and book of instructions supplied.

Price £14 14s. 0d. complete.

Write for technical brochure



TAYLOR ELECTRICAL INSTRUMENTS LTD.
419-424, Montrose Avenue, Slough, Bucks.
Phone: Slough 21381. Grams: "Taylins Slough."

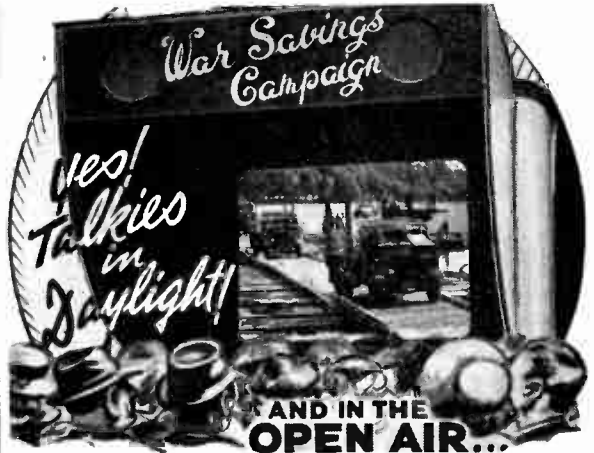

AND IN THE OPEN AIR...
The large fleet of Daylight Mobile Cinemas operated by British Films, Ltd., cover thousands of miles each year, bringing entertainment news and views to places and people so remote or so busy that "the pictures must come to the people." Naturally, in these days, such a valuable service is fully engaged on work of National Importance; but fullest information on the post-war potentialities of the Mobile Daylight Cinema as it can affect your business will gladly be sent on request.

BRITISH FILMS LTD.
Pioneers in Mobile Cinemas

Head Office: 199, PICCADILLY, LONDON, W.1. Tel.: REGent 2828
Works: 260, HIGH RD., BALHAM, LONDON, S.W. Tel.: BATersea 8506

Instrument Cases

If you are on Priority Work, IMHOF's Engineering Division can place a well-equipped modern plant and a wide experience at your disposal for the building of high-grade Instrument Cases, Chassis, etc., in metal.

IMHOF'S
CONTRACTORS TO THE ADMIRALTY,
AIR MINISTRY, MoS and G.P.O.

ALFRED IMHOF, LTD., 112-116, NEW OXFORD STREET, LONDON, W.C.1. MUSEUM 5941



Polarised Relays

Air Ministry type, high speed (V.F.) Relay. A modern instrument in cast alloy case, 2½in. dia. × 4½in. high. The Relay is mounted on high-grade Paxolin base, 2½in × 2½in. × ½in. with 8 pins for connecting. It is polarised by a 3in. horseshoe magnet. Separate adjustments are provided for magnetic bias on armature. Large size operating coil with double windings 24 ohms and 13,500 ohms; alloy armature carries double contacts providing single-pole change-over switching with large adjustable fixed contacts. All contacts are of platinum and will carry 60-watts non-inductance load.

All contacts, windings and metal case are insulated from each other and brought out to pins on Paxolin base. The actuating current is 8 volts at 0.6 m.a. Speed approx. 100 c.p.s. Price **£3.5.0**

Polarised Double-Acting Relays

These are telephone type Relays with polarised differential movement. Two 500-ohm windings. Large diameter contacts. A typical example of first-class workmanship. As illustrated **17/6**

ELECTRO-MAGNETIC RELAYS. Brand new surplus stock, make and break units to operate on 1½ v. at 15 m.a.; to clear stock **5/9**

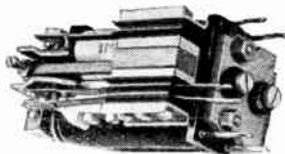

MANUFACTURER'S STOCK :

HEAVY DUTY MAINS TRANSFORMERS

Input 200-250 v. A.C., 350-0-350 v. 120 m.a., 4 v. 2 a., 4 v. 3 a., 6.3 v. 4a. Weight 11 lbs. **33/6**

HEAVY DUTY CHOKES, 140 ohm, 150 m.a. **17/6**

SLIGHTLY USED VALVES—PERFECT.—X65

Osram-Marconi Triode Hexode, 10/-, MHLD 6.3 v. Double-diode-triode, 7/6. Battery Triode H.F. Detector, 2 v., 4/6. VW48 Battery S.G., 2 v., 8/-, VT51 Battery Pentode, 2 v. 5-pin, 7/6. VR57 Frequency Changer, 10/-, P220 Battery Power, 2 v. 4-pin, 5/-, VT55 D.D. Triode, 6.5 v., 2 amp., 7/-, Mercury Vapour Rectifiers, 8/-, Battery Power, 2 v., 5/-.



MAINS TRANSFORMERS
A special line of newly manufactured British transformers. 350-0-350 v. at 80 m.a., 6.3 v., **37/6**
3a., 5v. 2a size
Post and packing 1/3 extra.

EXTENSION SPEAKERS.

Brand new, first-class P.M. speakers in beautifully polished cabinets **52/6**
In Rexine covered cabinets **50/-**

LOUDSPEAKERS

ROLA 10in. P.M. Speakers, 35/-, **CELESTION** 8in., with transformer, **29/6**.

GOODMANS P.M. SPEAKERS, without transformers: 5in., 21/-; 8in., 30/-; 10in., 47/6. Post and packing, 1/6 each extra.

MANSBRIDGE TYPE METAL-CASED CONDENSERS

350-V. WORKING	
4 mfd., 4 × 1½ × 2in.	6/6
2 mfd., 4 × 1½ × 2in.	4/6
2 mfd., 4 × 1 × 1½in.	2/6
2 mfd., 2½ × 1 × 1½in.	2/6
.02 mfd. Size 4½ × ½ × 1½in.	1/6
.2 + .2 mfd. Size 2½ × ½ × 2in.	2/6
Also 250 mfd., 25 v., in Bakelite case	2/6

CORRECTION

Last month the price of these was incorrectly printed, and should have read

500-V. WORKING

2 mfd. Size, 4½ × 3 × 2½ in. **5/6**

PLATINUM CONTACTS

Double Spring, mounted on ebonite

1/6



PENTODE OUTPUT TRANSFORMERS

Well-made and efficient. Suitable for Small Speakers.

Size 1½ × 1½ × 1½ ins.

7/-

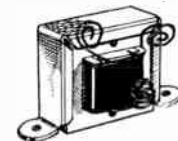

Miscellaneous Offers from last column:

CONDENSERS. First-class 0.1 mfd., oil-filled, 5,000 v., working, only 11/6 each.

TWIN SCREENED PICK-UP LEADS, fitted 2 plugs, 8ft. 6in. long, 2/0.

LONDON CENTRAL RADIO

Miscellaneous Offers:

ELECTRO-MAGNETIC COUNTERS. Ex-G.P.O. every one perfect, electro-magnetic, 500 ohm coil, counting to 9,999, operated from 25 v.—50 v. D.C., many industrial and domestic applications, 6/-.

VIBRATOR UNITS Synchronous. Brand new American self-rectifying vibrator units, 12 v. input, 280 v. output, 65 m.a., fitted with 7-pin American base, 16/-.

SCANNING AND DEFLECTOR COILS. Ex-television receivers, assembled to complete in metal frame, 7/6.

ELECTRIC SOLDERING IRONS. 200-250 v., 65/75 w., 12/6.

6-GANG SUPERHET VARIABLE CONDENSERS, 0.005 mfd., with trimmers, 10/6.

YAXLEY TYPE WAVE-CHANGE SWITCHES, 4-way, 3-bank, with shielded oscillator section, length from stop plate approx. 5in., spindle 2in., 6/3; 5-way, 6-bank, with 3 screened sections, adaptable to many uses, length from stop plate approx. 6½in., spindle 2in., 7/3; 3-way, 3 double banks, without shields, 2in. spindle, length 6½in., 6/3.

YAXLEY PATTERN SWITCHES, 5-way, single bank, on-off mains switch, carrying 1 amp. at 250 v., 2in. spindle with knob, 6/-; 3-way, single bank, 1in. spindle, with knob, 3/3.

OAK SWITCHES, 2½in. spindle, complete with knob, 4-way, 2-bank, with connecting block, 5/-; 4-way, 2-bank, 4/3.

MOTOR TUNING. Fine brand new 3-gang 0.0005 mfd. condenser, no trimmers, designed for motor drive, large diameter driving disc and reduction gear for slow motion manual drive, 13/6 each.

BRASS ROD. Screwed brass rod, 2 B.A., 4 B.A., and 6 B.A., 12in. lengths, useful for many purposes, 5/6 doz. lengths.

VALVE-HOLDERS, all brand new, Celestion Amphenol, Mazda and Inter. octal, 1/-.

VALVE-HOLDERS. Paxolin, 7- and 9-pin, 7d. each, 6/- doz.

DROPPING RESISTANCES. To replace 2- and 3-way line cords, with diagram showing connections, 0.3 amp., in strong metal case, 13/- each; without case, 10/- each.

VITREOUS ENAMELLED RESISTANCES, 10,000 ohm, 10 w., 3/6.

ELECTRIC RAZOR RESISTANCES, universal input, in strong metal case, 10/- each.

REACTION CONDENSERS. Fine quality job, 0.0003 mfd., to clear at 2/3 each.

TUBULARS. Wire-end tubular condensers, 0.1 and 0.01 mfd., 400 v. working, 1/-, 2 mfd., 400 v., 3/6.

COSSOR 0.025 CONDENSERS, 8,000 v., 7/6.

METAL-CASED CONDENSERS, 0.03 mfd., 500 v., 1/3.

T.C.C. TUBULAR CONDENSERS, 0.1 mfd., 6,000 v. D.C. test, 8/9; 0.04 mfd., 350 v., 2/-; 0.22 mfd., 350 v., 1/-.

T.C.C. CONDENSERS in metal cases, special offer, much reduced to clear, 4 × 4 mfd., 70 v. working, 2/6 each.

EX-GOVT. PLUGS AND JACKS, as previously advertised, 5/9.

EX-G.P.O. PLUGS, 1/9.

METAL SCREENED ANODE VALVE-CAPS, with short screened lead, 9d.

RED BAKELITE ANODE CAPS, 1/-.

HEAVY METAL SCREENED CABLE. Single, 1/-, Twin, 1/6 per yd.

TRIMMERS. Postage stamp 40 PF., 6d. Twin 40 + 40 PF., 1/-.

PHILIPS POTENTIOMETERS. 100,000 ohm. With switch, 4/6, without switch, 3/6.

CARBON POTENTIOMETERS, 50,000 ohm., 5/6.

DIAL LAMPS. Philips' screw type dial lamps for dial illumination, 15 watt, 1/9 each.

SPEECH COIL RIBBON WIRE, enamelled copper, gauge approx. 20 thou. by 5½ thou., 3/3 per lb. reel; also 23 s.w.g. d.c.c. wire, 100 yd. coils, 5/6.

LONDON CENTRAL RADIO STORES

23, LISLE STREET, 'Phone: GERrard 2969 LONDON, W.C.2



THE
SIMMONDS NUT

PINNACLE
NUT

SPIRE NUT

SIMMONDS
INSTRUMENTS
& CONTROLS

SIMMONDS
ELECTRONIC
PRODUCTS

FRAM OIL
AND ENGINE
CLEANER

CANDIDATE for SIMMONDS

Portrait of a young man discovering early in life that you can't put the clock back. Never mind! It was a poor clock anyway. When the hands said 4.25 the time was roughly a quarter to six. Not good enough for this lad. He took it to bits to find out why.

This is the kind of boy who'll be coming to us in a few years for a job — and he's likely to get one.

His technique is a bit clumsy but he has the right idea. We too spend a good deal of thought on slow and unsatisfactory processes in industry. We like to take the thing to bits, and see why it's made that way, and how to save lost time. And if speeding up means scrapping the clock and designing a new one, well, Simmonds have done that in more than one instance.

Are you losing time anywhere? Then you might let us "have a go" at the problem.

finding
new
and
better
ways



Simmonds Aerocessories Limited, Great West Road, London. A Company of the Simmonds Group

S I M M O N D S
LONDON · MELBOURNE · MONTREAL · PARIS · NEW YORK

Wireless World

Radio • Electronics • Electro-Acoustics

33rd YEAR OF PUBLICATION

MARCH 1944

Proprietors :
ILIFFE & SONS LTD.

Managing Editor :
HUGH S. POCOCK,
M.I.E.E.

Editor :
H. F. SMITH.

Editorial, Advertising
and Publishing Offices:

DORSET HOUSE,
STAMFORD STREET,
LONDON, S.E.1.

Telephone :
Waterloo 3333 (35 lines).

Telegrams :
"Ethaworld, Sedist, London."

△

PUBLISHED
MONTHLY

Price : 1/6

(Publication date 25th
of preceding month)

Subscription Rate :
Home and Abroad
20/- per annum.

Branch Offices :

COVENTRY :
8-10, Corporation Street,
Telephone : Coventry 5210.
Telegrams :
"Autocar, Coventry."

BIRMINGHAM :
Guildhall Buildings,
Navigation Street, 2.
Telephone :
Midland 2971 (5 lines).
Telegrams :
"Autopress, Birmingham."

MANCHESTER :
260, Deansgate, 3.
Telephone :
Blackfriars 4412 (4 lines).
Telegrams :
"Iliffe, Manchester."

GLASGOW :
26B, Renfield Street, C.2.
Telephone : Central 4857.
Telegrams : "Iliffe, Glasgow."

△

As many of the circuits and
apparatus described in these
pages are covered by patents,
readers are advised, before
making use of them, to satisfy
themselves that they would
not be infringing patents.

COMMENTS OF THE MONTH	65
U-H-F WAVEMETER. By A. H. Beattie and L. Knight	66
MORE ABOUT RADIO HEATING. By L. L. Langton, A.M.I.E.E.	70
NOVEL P-A GEAR	73
LETTERS TO THE EDITOR	74
U.S.A. PLANS POST-WAR RADIO. By D. A. Bell, M.A.	76
UNBIASED. By Free Grid	78
AIRCRAFT RADIO By Charles B. Bovill	79
RADIO DATA CHARTS—No. 15 : IF Transformer Design. By J. McG. Sowerby, B.A., Grad.I.E.E.	82
MATCHING—III : Transmitter Aerial Couplings By S. W. Amos, B.Sc. (Hons.), Grad.I.E.E.	86
WORLD OF WIRELESS	88
NEWS IN ENGLISH FROM ABROAD	90
"WIRELESS WORLD" BRAINS TRUST	91
NEW CONTRAST EXPANSION UNIT. By M. O. Felix	92
RANDOM RADIATIONS. By "Diallist"	94
RECENT INVENTIONS	96

Miniature I.F. Transformers

DESIGNED FOR MAXIMUM
GAIN AND SELECTIVITY IN
THE SMALLEST DIMENSIONS

The coils are contained in enclosed pot-type iron dust cores, tuning adjustments being obtained by means of adjustable iron dust centre cores.

Fixed tuning condensers are contained inside the screening can.

The following frequencies are preferred standards but others are available for particular applications :—

M.400 - - 460 Kc/s. M.405 - - 1.6 Mc/s.
M.411 - - 2.1 Mc/s. M.415 - - 4.86 Mc/s.
M.418 - - 9.72 Mc/s.

Wartime restrictions prevent our accepting orders other than those covered by priority numbers.

The illustration shows the actual size of the Unit which is provided with one hole fixing, the terminal wires being fed through insulated bushings which, in turn, prevent movement of the transformer when mounted in position.

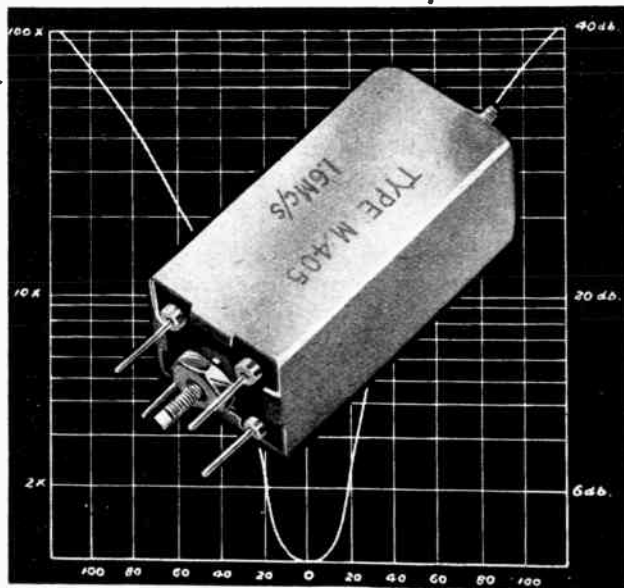

WRIGHT & WEAIRE LTD.

HIGH ROAD, TOTTENHAM, N.17.

Telephone : TOTtenham 3847-8-9.



Porcelain

His day's work done, he becomes one with the crowd on its homeward way, and there is nothing to distinguish him from his accustomed background. But we know him as a highly skilled craftsman who controls a white-hot furnace which is baking porcelain. Not the kind that will ever grace a tea-table, but a high grade of ceramic material with special electrical properties used in the manufacture of resistances, valves and many other components vital to

radio communications.

Much depends on their unfailing reliability—and so Philips, whose manufacturing resources extend from raw material to finished product, make their own porcelain to their own exacting standards.

He is one of the thousands of workers who gave you, before the war, the Philips products you knew and trusted so well. *His skill is a vital asset to the nation today.*

PHILIPS



RADIO ★ LAMPS

AND ALLIED ELECTRICAL PRODUCTS

PHILIPS LAMPS LTD., CENTURY HOUSE, SHAFTESBURY AVENUE, W.C.2 (411)

Wireless World

Radio • Electronics • Electro-Acoustics

Vol. L. No. 3

MARCH 1944

Price 1s. 6d

Comments of the Month

Frequency Allocations—Centralised Research—Discs

IN last month's *Wireless World* we pleaded that an attempt should be made at once to settle those international aspects of frequency allocation that affect large-scale wireless production. The proposal was put forward with diffidence, as to hope for anything approaching international agreement seems impossible while a world war is raging. It is, therefore, all the more gratifying to find that our suggestion has been well received; it is generally realised that it would be intolerable if sections of the wireless industry were forced to mark time in a state of uncertainty for months—or years—after the end of active hostilities. Even America, less dependent on her neighbours than overcrowded Europe, is forced to take international allocations into account. A contributor, writing in this issue on American plans for post-war radio, touches on this matter, and suggests a United Nations Frequency Conference. Although objection can be made to that suggestion, it would provide a solid foundation on which to build.

Standardising Electricity Supplies.—A recent report by the Institution of Electrical Engineers suggesting an early post-war change to a standardised AC supply will be welcomed in wireless circles. From our point of view the most important result of the change-over to AC, if it can be made as rapidly as is recommended, will be greatly to assist the early re-establishment of television. Lack of a domestic AC supply is in practice a virtual barrier to the installation of a television receiver.

Co-operative Wireless Research.—One of the strongest arguments that can be adduced in favour of a non-profit wireless research organisation is that radiolocation, which has served our cause so well, was based mainly on the work of scientists who investigated reflection phenomena without concerning themselves with the immediate financial gain likely to accrue from their labours. That is one of the points brought forward by the British Institution of Radio Engineers in presenting a proposal for the establishment of a British Radio Research Institute to engage in "basic research of the type that has hitherto suffered restriction

owing to its high cost, absence of obvious or immediate practical applications, or the poor prospect of early financial returns." The institution, which would be "financed by industrial subscriptions supplemented by a Government grant of at least equal amount," would, it is suggested, be directed by a board comprising representatives of the Government (including the Services and B.B.C.) industry, the Brit.I.R.E. and associated professional institutions and Universities of the Empire. *Wireless World* has long stressed the need of co-operative research, if only to avoid much of the waste of human endeavour that is inherent in the present system. It is not proposed that individual manufacturers should abandon research, but rather that they should concentrate on applying the fundamental work of the co-operative organisation.

Scope for Inventors.—True to "Brains Trust" traditions, the discussion that has been going on in our pages has failed to provide a clear-cut and unanimous answer to the question, "Is the disc gramophone record obsolete?" But many interesting facts have come to light, and at least one definite conclusion can be drawn. We may agree that existing gramophone practice is, by and large, satisfactory enough and still capable of development; alternatively, we may, like one contributor, express disgust at a system that depends on "scraping a steel point carrying some tons of weight per square inch over what is virtually a refined macadamised roadway." But none of our contributors has been bold enough to put forward without reservation a proved and ready-made successor to the disc record. It seems clear enough that neither inherent conservatism nor wicked "vested interests" tie us to a form of domestic reproduction that admittedly seems crude. Here, it would seem, is a fruitful field for an inventor to devise a system free of all shortcomings. Increased playing time, freedom from rapid deterioration, easy manipulation and storage, combined with easily attainable quality of reproduction at least as good as the best obtainable from discs, are the principal requirements.

UHF WAVEMETER

Range 70-270 Mc/s
with Quartz Crystal
Frequency Standard

By

A. H. BEATTIE

and

L. KNIGHT

(Murphy Radio Limited)

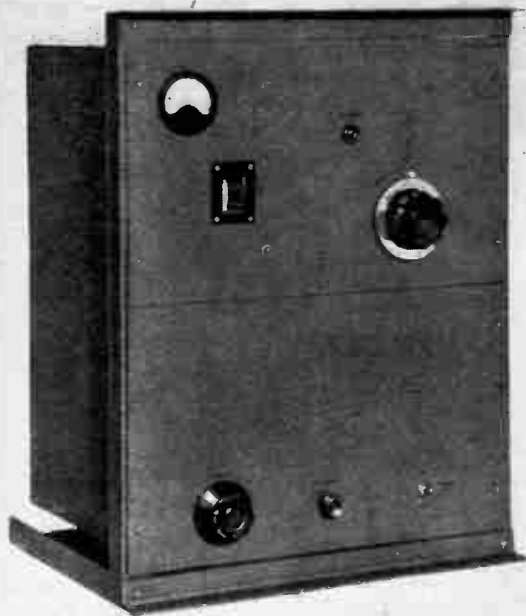

General views of the complete instrument. In the lower photograph, the dust cover and back plate of screened UHF unit have been removed.

CONVENTIONAL methods of measuring ultra-high frequencies with Lecher wire systems must always be cumbersome and, even if used with extreme care, cannot be relied upon to give very accurate results. In the development of this wavemeter it was decided, therefore, to concentrate on a simple heterodyne method which could use a quartz crystal as its frequency standard. Such an arrangement, it was thought, would give speed and reliability of measurement combined with reasonable portability.

The first requirement appeared to be a wide range UHF oscillator against which the unknown frequencies could be compared, with some provision for checking the calibration of this oscillator against the harmonics of a crystal oscillator. It was realised that merely mixing the signals and tuning audibly for zero beat would be far from satisfactory at these frequencies. Even if an amplifier and speaker giving a substantial response up to 15 kc/s were used, a heterodyne would only be audible over a tuning range of 30 kc/s, and would be extremely difficult to find with an oscillator covering a range of nearly 200 Mc/s. Consequently, the solution seemed to be to feed the beats from the mixer into an amplifier, the frequency response

of which could be specially arranged to indicate zero beat visually on a moving-coil meter.

Fig. 1 shows the general outline of the arrangement adopted. Fig. 2 shows the schematic circuit, and it is proposed now to explain this stage by stage, paying special attention to the more important electrical and mechanical points.

UHF Oscillator. — At ultra-high frequencies oscillator design is very closely bound up with the design of the tuning condenser. It was therefore decided to make a special condenser for the instrument, patterned basically on the now unobtainable G.R. variable condenser, Type 755A, but having its main features arranged to suit our particular requirements.

One of the most important points which had to be borne in mind was that of keeping the series inductance very small. The necessity for this is well illustrated by the fact that for a frequency

range of 70 to 250 Mc/s, assuming a tuning capacity range of 130 $\mu\mu\text{F}$ to 10 $\mu\mu\text{F}$, the total tuning inductance required in the circuit is of the order of only 0.04 μH .

The first and most obvious factor affecting series inductance was the physical size of the condenser; it was therefore important that this should be as small as possible. The rotor lead should be short and should be taken into the centre of the rotor assembly.¹

A linear frequency law would have been desirable, but such a law necessitated very eccentric rotor plates and the stators would then have had to be large to accommodate them. This, unfortunately, would have seriously increased the residual inductance, and it was necessary to choose a rotor plate shape which was more semi-circular yet which would give an acceptable frequency law.

¹ D. B. Sinclair. "A High Frequency Model of the Precision Condenser." *G.R. Experimenter*, October and November, 1938.

The plate shape giving a logarithmic law appeared to be a reasonable compromise.

The condenser frame consists of a five-sided box of $\frac{1}{4}$ in. brass, with ball-races mounted on opposite sides to carry the rotor assembly. The rotor plates are of brass and are soldered into slots in a section of brass tube, the latter being attached to a steel spindle by "Distrene" blocks. The stators (also brass) are similarly fixed into slots in a brass bar mounted on two "Distrene" strips which bridge the open end of the frame. A small brass bar mounted on one of these "Distrene" strips holds a three-fingered wiper against a slip-ring on the rotor assembly. The tuning inductor (L_2) is mounted directly on the condenser; it consists of a 270-degree arc, 1 in. dia., made of 14 SWG copper wire, and, in common with all the brass parts of the condenser, is silver plated.

In order to facilitate tuning a slow-motion drive incorporating a worm and a spring-loaded split gear-wheel is used, giving a reduction ratio of approximately 20:1. The main tuning scale is engraved on a $\frac{1}{4}$ in. dia. "Erinoid" drum, attached directly to the rotor spindle, and is augmented by a degree dial on the tuning knob.

The obvious choice for an oscillator valve seemed to be an acorn type, and the American 955 (V_3) was found to give excellent results. The valveholder is mounted on one of the "Distrene" strips on the tuning

condenser so that the anode-stator and grid-rotor connections are as short as possible. The grid capacitance (C_3) is formed by a $\frac{3}{8}$ in. square brass plate separated from the stator fixing-bar by 0.005 in. of mica. The cathode is earthed directly to a soldering-tag on the corner of the frame, as it was found essential to keep this earthing lead short (less than $\frac{1}{8}$ in.) in order to prevent spurious oscillations occurring with the tuning condenser at minimum capacitance.

Fig. 1. Schematic arrangement of crystal controlled UHF wavemeter.

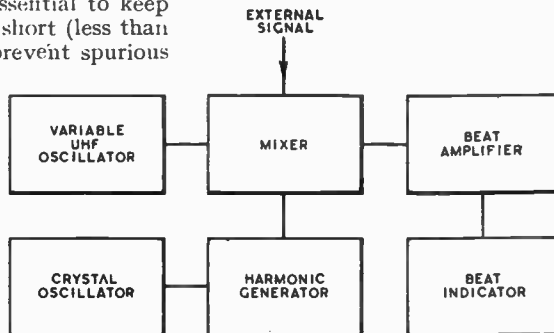

It was found advisable to feed the HT to the oscillator inductor through a high impedance, since, due to the large range of the tuning condenser, the voltage node deviated slightly from the mechanical centre of the inductor at some frequencies. A $\frac{1}{8}$ in. dia. self-supporting choke (L_8) wound with 17 turns of SWG enamelled wire was found satisfactory.

To prevent any change of frequency due to the slight increase in HT volts when switching off the crystal oscillator, the HT supply to the UHF oscillator is regulated by a Cossor S130 neon stabiliser (N).

Crystal Oscillator.—This oscillator employs a 10 Mc/s crystal

in an orthodox circuit. The valve used (V_4) is a VR65 (6.3-volt counterpart of the Mazda SP41) which, connected as a triode, makes an excellent oscillator and reduces the number of different types of valve in the instrument. In order that the maximum possible 10 Mc/s volt-

age may be fed into the following stage, the anode circuit (L_3, C_4) tuned to that frequency is arranged to have a high L/C ratio.

Harmonic Generator.— This stage consists of a Type 955 acorn triode (V_1) which, being considerably overloaded, produces a long train of strong harmonics. Reducing the bias on this valve assists in the distortion, and the cathode resistance (R_1) is made as small as possible without exceeding the maximum grid current rating of 1.4 mA. The best form of anode load was found to be a self-supporting choke (L_1) consisting of 20 turns of 20 SWG enamelled wire, and having a diameter of $\frac{1}{4}$ in. This choke, while having a reasonably high impedance over the range 70-270 Mc/s has a low impedance at 10 Mc/s. The 10 Mc/s voltage on the anode is therefore kept relatively low and does not flood the mixer.

Mixer.—At frequencies in the order of 250 Mc/s the conversion conductance of multi-grid valves is extremely low, and the natural choice for a mixer valve appeared to be a UHF diode, such as the Mullard EA50. It was found experimentally that the best method of coupling the diode (V_2) to the UHF oscillator was by the insertion of a $2 \mu\mu\text{F}$ condenser (C_2) between the diode anode and the HT tapping points on the oscillator inductor. The loading thus placed on the UHF

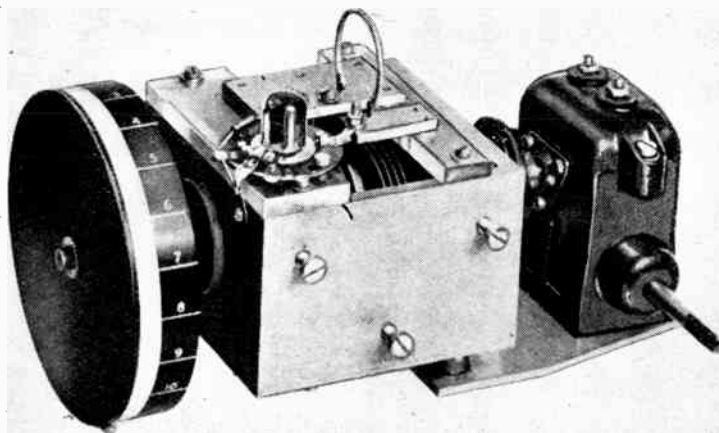

UHF oscillator unit. The reduction gear driving the tuning condenser is on the right.

UHF Wavemeter—

oscillator tuned circuit is negligible, since in practice this point is very near the voltage node of oscillation.

decoupled by two cup-type condensers. In the LT and the two HT filters (F₄, F₁, F₃) these condensers are each 100 $\mu\mu\text{F}$. In the BF filter (F₂), though, it is neces-

filter (F₂) to minimise the shunting of the diode by the filter at UHF.

Beat Amplifier.—The amplifier

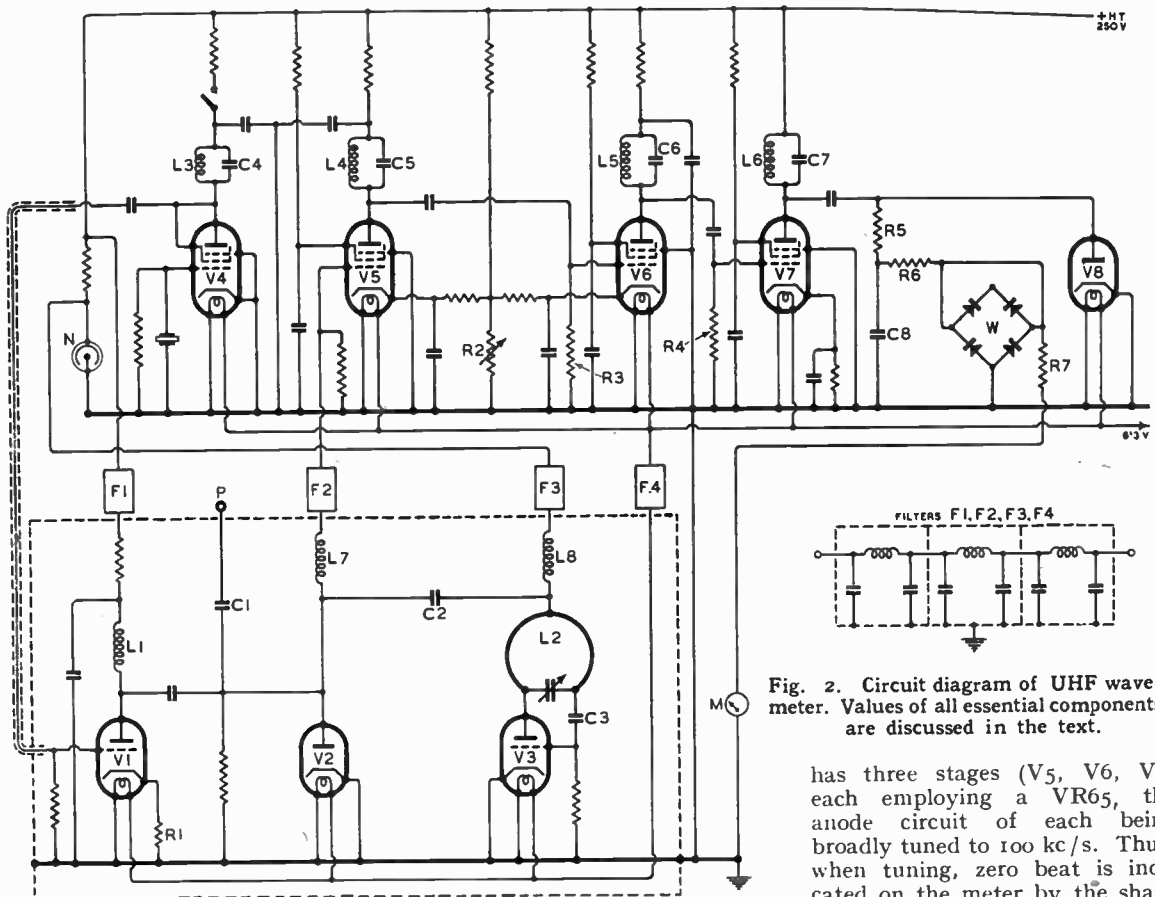

Fig. 2. Circuit diagram of UHF wavemeter. Values of all essential components are discussed in the text.

A concentric plug (P) is fitted on the front panel to enable external signals to be fed into the mixer. This plug is connected by another 2 $\mu\mu\text{F}$ condenser (C₁) to the diode anode.

The mixer stage is mounted very close to the UHF oscillator and the harmonic generator, the three stages being enclosed in a cast aluminium box, thus screening all the UHF sections of the circuit.

With the exception of the 10 Mc/s feed which is a screened lead, all connections into the box are taken through filters (F₁, F₂, F₃, F₄). The filters are housed in smaller castings mounted on the main oscillator box. Each has three inter-screened sections, each section consisting of a $\frac{1}{4}$ in. dia. self-supporting choke wound with 24 turns of 30 SWG wire

sary to use a considerably lower capacitance to prevent any serious attenuation of the beat notes, and 5 $\mu\mu\text{F}$ condensers are used. A choke L₇, which is similar to L₈, is placed between the mixer anode and the

Top and bottom views of mixer and harmonic generator unit.

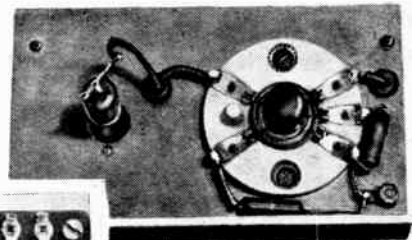
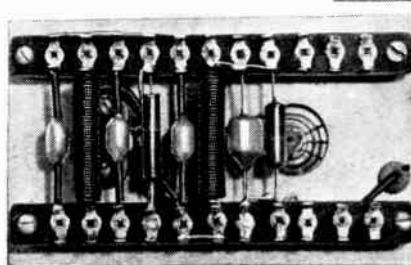

L₅C₆, L₆C₇) are used, and they are damped by shunting them with low-value resistors (R₃, R₄, R₅). This gives a response curve which falls off gradually above 100 kc/s, making the beats

easy to find, but which is steep below about 50 kc/s, allowing a sharp setting of zero beat (see Fig. 3).

Beat Indicator.—The amplified beat notes are rectified by another EA50 diode (V8) and the diode-load current used to operate a 500 μ A meter (M). To limit the meter current to about 450 μ A, a protection device is added which incorporates a 5 mA instrument rectifier (W) in conjunction with two suitably chosen resistors (R6, R7). This feature, besides merely preventing overloads on the meter, greatly assists the instrument's ease of operation by effectively flattening still further the overall frequency response of the beat amplifier.

A 2 μ F condenser (C8) was introduced into the meter circuit to give a fairly slow time-constant. This did not make the tuning sluggish and was completely successful in eliminating the tiny flickers which had been present originally, due to microphony in the UHF oscillator valve.

Operating Procedure. — When the UHF oscillator is tuned, with the crystal oscillator switched on, zero beat is indicated whenever the frequency passes through a multiple of 10 Mc/s. The tuning drum, besides carrying the arbitrary degree scale, has an approximate calibration in Mc/s, and thus it is an easy matter to identify the multiple of 10 Mc/s to which the UHF oscillator is tuned.

Fig. 3. Overall frequency response of beat amplifier and indicator.

Turning the gain control (R2) to a mid-way position brings into prominence beats at 65 Mc/s, 75 Mc/s, 85 Mc/s . . . 265 Mc/s. These are caused by the second harmonic of the UHF oscillator beating with the 13th, 15th, 17th . . . 53rd harmonics of the crystal oscillator. With the gain increased to maximum these beats become very strong and, in fact, the limiting effect of the meter protection circuit gives the impression that they are as strong as those corresponding to mul-

tiples of 10 Mc/s. Thus a reliable calibration check is possible every 5 Mc/s.

The procedure, therefore, in adjusting an external oscillator to, say, 168.5 Mc/s is first to find the dial reading on the internal UHF oscillator for 165 Mc/s and 170 Mc/s, and assuming a linear tuning-law, to deduce the dial set-

One of the filters (F1 to F4) with cast aluminium cover.

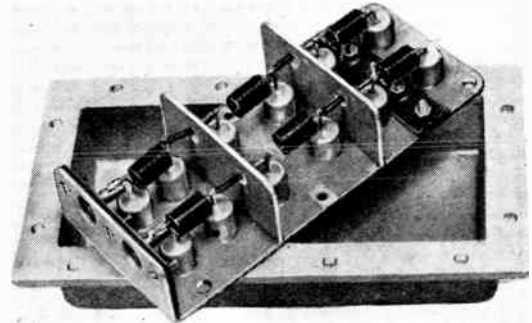

ting for 168.5 Mc/s. Then, with the dial at this setting and with the crystal oscillator switched off, the external oscillator is fed into the mixer and tuned for a zero beat indication on the meter.

Naturally, by applying a reverse process it is a simple matter to ascertain the frequency of an external signal.

The actual frequency range of the original model is 70-270 Mc/s, but provided that the external signal is strong it is possible to use the second and third harmonics of the internal UHF oscillator, thus making the effective range of the instrument 70-810 Mc/s.

The sensitivity of the instrument is high; on the original model the beats with an external signal of 200 μ V at 70 Mc/s give half-

(multiples of 5 Mc/s) is 50 kc/s at 70 Mc/s and 150 kc/s at 270 Mc/s.

Since the frequency law of the condenser is not linear, a small inaccuracy can occur when inter-

polating between spot frequencies. The backlash on the slow-motion drive also contributes a small discrepancy, although by careful tuning this can be practically eliminated. It has been found experimentally that the total error due to these causes rarely exceeds 100 kc/s and never exceeds 200 kc/s.

This instrument in its original form is unsuitable for measuring signals with certain special types of modulation, and the design has since been slightly modified. The first beat amplifier stage is now arranged to have an extended low frequency response and a condenser feed is taken from the anode to a socket on the front panel. From this socket, the amplified beat can be fed into an oscilloscope and a very satisfactory zero beat indication obtained.

In conclusion, we should like to express our thanks to Murphy Radio, Limited, for permission to describe this apparatus, and to Mr. E. A. Goldring, A.R.P.S., for providing the photographs.

OUR COVER

THE illustration reproduced on the cover of this issue shows an Eitel-McCullough 300-watt triode designed for operation at maximum rating at frequencies up to 40 Mc/s. The reproduction is approximately half size.

GOODS FOR EXPORT

The fact that goods made of raw materials in short supply owing to war conditions are advertised in this journal should not be taken as an indication that they are necessarily available for export.

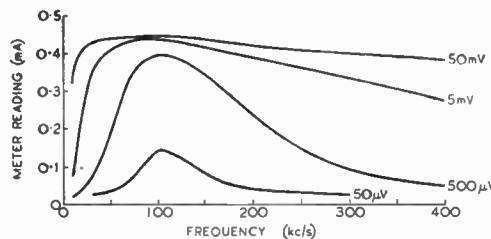

scale deflection on the meter, while at 270 Mc/s, only 100 μ V is required.

Accuracy.—The beat notes are easily tuned to less than 15 kc/s, and an accuracy of ± 0.05 per cent, being assumed in the crystal oscillator (which corresponds to ± 35 kc/s at 70 Mc/s, and ± 135 kc/s at 270 Mc/s), the total error possible at spot frequencies

RADIO HEATING

A GENERAL survey of the application of radio frequency power to industrial heating problems appeared in last month's issue of this journal. It is proposed in this article to expand some of the points already dealt with and to indicate some of the less obvious factors which must be taken into account by the designer of radio heating equipment.

Metals are heated by placing the "work" inside a coil carrying large RF currents. Eddy currents are induced in the outer layers of the work which become heated. This method is termed eddy current heating (ECH) and the frequencies normally employed range from 100 kc/s to 2 Mc/s. RF power below 100 kc/s is more economically generated by other than thermionic methods and this article is not concerned with its applications. On the other hand, at frequencies above 2 Mc/s the thickness of the layer heated is too small for most practical purposes.

The RF power required for the ECH of metal is, in most industrial applications, many times greater than the power required for heating dielectric materials. The reason for this is quite obvious when it is considered that in heating metals for the purpose of, say, surface hardening, the rise in temperature must be of the order of 800-1,000 deg. C. and must take place in a few seconds to prevent the heat penetrating by thermal conduction. With dielectrics, the temperature rise usually required is about 100 deg. C. or less and may conveniently take a full minute. Furthermore, the overall efficiency obtained with ECH is sometimes low, as it depends upon many practical compromises to be discussed later. The theory of ECH is fairly simple in its broad outline and will now be considered.

If a conductor of circular cross-section is carrying AC the current will crowd more and more towards the outer surface of the conductor as the frequency is

By

L. L. LANGTON

A.M.I.E.E.

Assembly for hardening the teeth of a screw tap showing central heating coil and outer casing from which a water spray is subsequently applied for quenching.

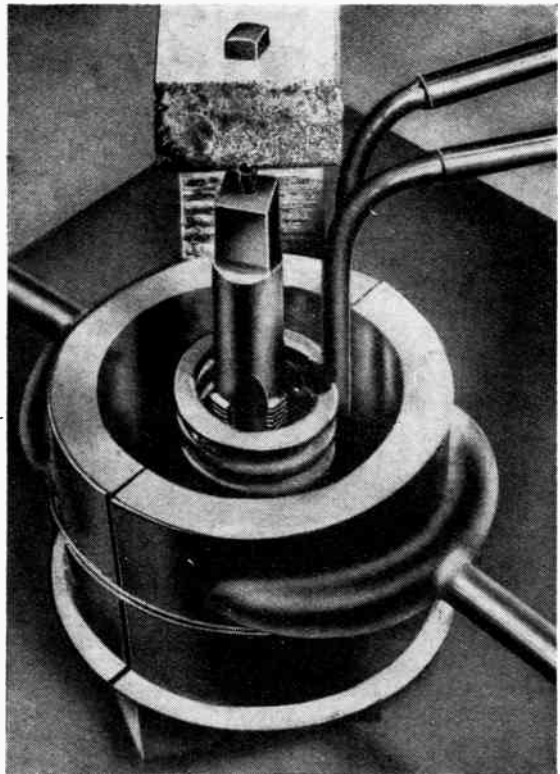

Courtesy: Lepel High Frequency Laboratories Inc.

raised. It will be recalled that the reason for this well-known skin effect is because the inductance of the core of the conductor is greater and hence its impedance to AC. If the conductor is made of magnetic material having a high value of permeability it is natural to expect this skin effect to be greatly enhanced because the inductance of the core will be increased by the permeability of the material. The amount of crowding depends upon the ratio of the resistance of the outer layers to the impedance of the core and so, for materials of high specific resistance, the skin effect would be less. According to Babat and Losinsky* 90 per cent. of the heat is generated in a thickness of

$$t = \frac{1}{2\pi} \sqrt{\frac{\rho}{\mu f}}$$

where t = thickness in cms.

μ = effective permeability of the material.

f = frequency in c/s.

ρ = specific resistance of material in C.G.S. units (i.e. ohms per $\text{cm}^3 \times 10^9$).

For carbon steel at 20 deg. C.

$$t = \frac{20}{\sqrt{f}} \text{ mm.}$$

Assuming that the current density within a layer of thickness t is constant it will be proportional to $\frac{H_t}{4\pi\rho}$, where H_t is the tangential component of the alternating field at the surface of the work.

The power dissipated by eddy currents will be proportional to $H_t^2 \rho / 16\pi^2 t$. Substituting for t , it will now be seen that the power dissipated in work $P \propto \sqrt{\rho\mu}$.

This is a very important expression for it shows that for a material to be heated efficiently by induced eddy currents, its specific resistance as well as its permeability must be high.

When magnetic material becomes heated, its permeability is reduced until a temperature is reached called the Curie point, at which the permeability is unity. The material is then no longer magnetic. It will be seen that this effect coupled with the

* Journ. I.E.E., Vol. 86, Feb. 1940.

fact that the specific resistance of the heated metal rises with temperature, will cause the heated layer to penetrate deeper into the work. For instance, above the Curie point (800 deg. C.) the thickness of the layer for carbon steel will be: $\frac{500}{\sqrt{f}}$ mm.

The energy required to heat the peripheral layer and then to penetrate layers of the work is transferred from the work coil by electro-magnetic induction. As the work itself forms the secondary of a transformer, it must have an impedance due to its own inductive reactance and resistance. It is the inductive component of the work which enables the energy to be transferred and the resistive component which converts it into heat. Magnetic work will have a greater inductive and resistive component than non-magnetic materials such as copper, brass, etc., which are mainly good conductors. It will be seen that to heat such materials as copper by eddy-current induction is wasteful, but may be justified in some industrial processes.

The wastefulness in heating non-magnetic materials of low specific resistance is caused by the fact that since the inductance of the work is low, the load which can be imposed upon the generator tends to be very light. This means that only a small percentage of the power of which the generator is capable can be extracted.

In practice the anode current of the generator is much greater for iron and steel than for copper "work" of equal size and shape. It is not unusual with copper to have an anode current which is only just perceptibly greater than the no-load current. This very small anode current rise with copper may be somewhat increased if the generator tank circuit dynamic resistance is very carefully matched to the impedance of the work. If the work coil which is optimum for iron is used with copper, very small anode current rises will be obtained. Similarly a work coil which is optimum for copper will give poor efficiency with iron.

To maintain heat in magnetic materials which have reached

their Curie point is not so wasteful, for, although the permeability is unity, the specific resistance of the heated portion will be very high, and such energy as is induced is sufficient to maintain temperature against thermal losses. Should, however, the material commence to cool owing to draughts, etc., the temperature would drop below the Curie point, and efficient heating conditions would again prevail. During the heating cycle of the work (whether it is magnetic or not) the power taken from the thermionic generator will be anything but constant, because the permeability and/or specific resistance of the work will be constantly changing as its temperature rises.

It has been tentatively suggested that the power rating of equipment supplied for heating should be stated as the power capable of being delivered into a definite resistive load. In the case of ECH this may be particularly misleading to a purchaser who is interested to know how much heat he can get into a specified piece of work. We have seen that the power capabilities of the thermionic generator are by no means the only factor determining the amount of heat the work will receive.

The amount of heat required to do a certain piece of work is

the product of the weight, the specific heat of the material and the temperature rise required. The answer is given in calories if the units are grams and degrees Centigrade, and in British thermal units if the units are pounds and the degrees Fahrenheit. To convert this heat energy into electrical energy, the constants are:

$$1 \text{ calorie} = 4.2 \text{ joules or watt-seconds.}$$

$$1 \text{ B.T.U.} = 1,080 \text{ joules or watt-seconds.}$$

For the work to be heated in a specified time the number of watts of energy that must be induced is easily found.

Eddy current heating shows to best advantage in work requiring selective heating where only a part of the job requires hardening, or other special heat treatment. To give an example, a long rod of metal was required to have a hardened surface, with the exception of short lengths at each end which were to be left soft for riveting. To perform such a hardening job by old methods would be complicated and costly, but by ECH it was done as follows. The work coil was wound to cover the part required to be hardened, leaving a short length projecting at each end. The work coil and work were submerged in water and when power was applied the portion inside

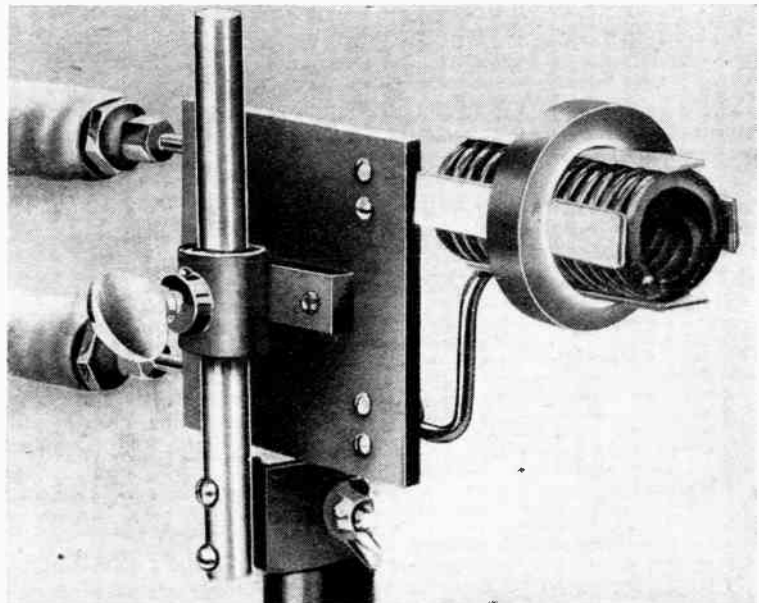

Courtesy: Lepel High Frequency Laboratories Inc.
Internal coil for localised heating of the inner surface of a steel ring.

More About Radio Heating—

the work coil quickly became raised to red heat, and formed a layer of water vapour which insulated it thermally from the water. The temperature rise in the exposed ends was, of course, very small and when power was shut off the water quickly quenched and hardened the hot metal.

Dielectric Heating

Insulation materials are heated by using them as the dielectric for a condenser which is across the tank circuit of a power oscillator or amplifier. Displacement currents set up in the dielectric by the alternating potential on the condenser electrodes heat the dielectric uniformly throughout its mass. There is, of course, loss of heat to the atmosphere and to the electrodes, which tends to keep the outside of the dielectric mass cooler. This method is usually referred to as dielectric heating. Frequencies commonly employed range from approximately 5 Mc/s to 20 Mc/s.

The insertion of the insulator into the condenser will increase its capacity from the value it had when using air as the dielectric. The ratio of this increase is called the dielectric constant of the insulation material. This ratio is not constant, however, and is found to decrease with rising frequency, particularly at high frequencies.

The power factor of the condenser depends upon its capacity and the value of the effective shunt resistance which, in a practical case, is controlled by the type and dimensions of the dielectric being heated. The shunt resistance of a condenser may be converted to an equivalent series resistance, and the power factor ($\cos \theta$) is the ratio of this series resistance to the impedance of the condenser.

The power absorbed in a condenser dielectric is proportional to the square of the applied RMS voltage, the reactance (or more precisely the impedance) and the power factor of the condenser. When considering the power absorbed and hence the heating of the dielectric, the capacity is better expressed in terms of the electrode area, the distance between electrodes and the di-

Material	Frequency			
	1 Mc/s	10 Mc/s	25 Mc/s	50 Mc/s
Phenolic woodflour powder ...	0.130	0.156	0.161	0.160
Phenolic asbestos powder ...	—	0.351	0.244	—
Urea cellulose powder ...	—	0.123	0.144	—

electric constant of the material (K). The expression now becomes

$$P = \frac{0.255 \omega E^2}{10^{12}} \cdot \frac{A}{d} (K \cos \theta) \text{ watts}$$

where A = area in square inches,
d = electrode spacing in inches,

$$\omega = 2\pi f$$

and where V is the volume of the dielectric in cubic inches

$$P = \frac{0.225 \omega}{10^{12}} \left(\frac{E}{d} \right)^2 V (K \cos \theta) \text{ watts.}$$

Power and hence heat in the dielectric is seen to (1) increase with frequency for a constant power factor. (2) Increase as the square of the potential gradient (E/d). (3) Increase directly with the volume of the dielectric. (4) Increase with the product of dielectric constant and power factor. The rate of increase in each of these four cases is slightly modified by the variable factors mentioned earlier. In some practical applications of dielectric heating there is another variable due to the presence of moisture in the cold dielectric, which is evaporated away on heating. Such dielectric materials have to be heated between mesh electrodes in order that the water vapour may escape.

The product of dielectric constant and power factor is termed the loss factor of the material. This is the index to be considered in deciding which materials may be economically heated in dielectric methods. The loss factor for a material will vary with frequency and the point at which the loss factor is a maximum may influence the choice of heating frequency. It cannot, however, be the deciding factor for, at the selected frequency, the potential gradient may need to be so great for a reasonable heating time that a breakdown in the dielectric would occur.

Loss factors for some moulding materials over a range of frequencies have been measured and published by Bakelite Ltd., and are given in the accompanying

table. It will be noted that they do not vary according to any expected law. As a standard for comparison it is convenient to remember that the loss factor for ruby mica—a good insulating material—is 0.0008 at 2 Mc/s.

As mentioned earlier, dielectric heating does not usually require such large power as ECH. Useful work of a diverse nature may be done in the average moulding shop with the powers as low as 500 watts, while ECH apparatus of equally large industrial application would need a power of about 5–10 kW.

The main application of dielectric heating of medium and low power is in moulding where it obviously means bigger, better and faster moulding. Dielectric heaters of high powers (200–300 kW) have been used in making plywood. The areas concerned are very large and the thickness of the ply is not limited provided sufficient power is available. Food dehydration also requires high powers as the quantity of food treated must for commercial reasons be fairly large. These fields of application for dielectric heating may be considered at the present time to be the most useful for industrial purposes, though others will doubtless be developed in the near future.

THE WIRELESS INDUSTRY

A PAMPHLET with data on B.I. thermo-plastic cables and flexible cords with polyvinyl chloride insulation has been issued by British Insulated Cables, Prescott, Lancs.

Callender's Cable and Construction Company has appointed H. J. Allcock, M.Sc., M.I.E.E., to be Works Controller of its Northern factories. Eric Bowyer, B.Sc., is to be Production Manager of the Company's Anchor Works and associated factories.

The wireless and allied industry is giving good support to the War Savings campaign. Last year the Marconi Group membership subscribed nearly £100,000, while the year's total of W. T. Henley's Telegraph Works approached £50,000.



NOVEL P-A GEAR

New Installation at L.N.E.R. Terminus

AUTOMATIC volume control, in a novel but quite literal sense, is provided in the new public address system recently installed at Liverpool Street Station, the London terminus of the London & North-Eastern Railway. The volume of some of the groups of loudspeakers is automatically adjusted in relation to the prevailing noise level of the

Rear view of the automatic control relays and power supply unit. Inset is the announcer's control panel and microphone.

station by the use of noise detector microphones. The output from these is applied to a microphone amplifier by means of which a varying DC bias proportional to the noise level is applied to one of the valves of the pre-amplifier.

The installation has been designed by Central Rediffusion Services in co-operation with the L.N.E.R. Chief Engineer's Department to overcome acoustic and other problems arising out of the heavy volume of traffic passing through this busy terminus. These problems have been met, first by directing beams of sound down each individual platform so that speech is not audible on ad-

The two rack-mounted pre-amplifiers, below which is the noise-control amplifier.

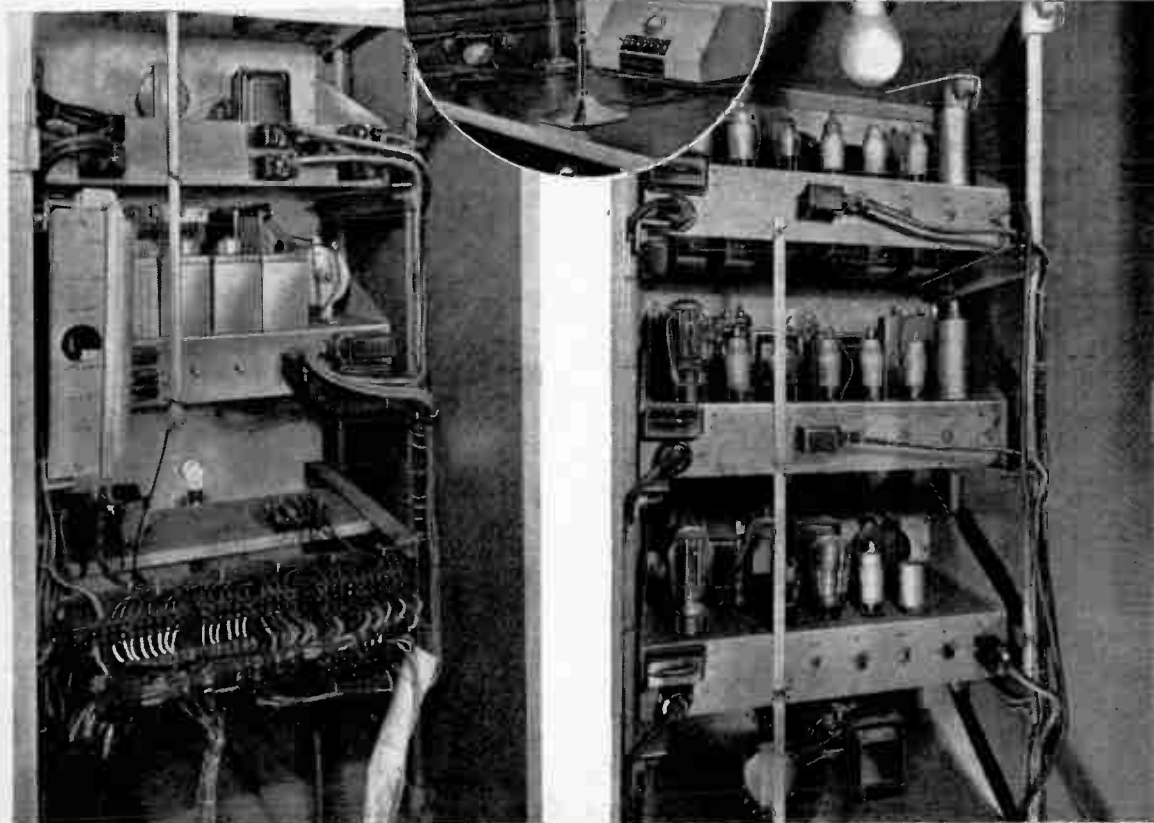

Novel P-A Gear—

jacent platforms; secondly, by giving a wide angle of diffusion of speech in the circulating areas;

Some of the fifty-one directional loudspeakers silhouetted against the smoky atmosphere. Inset is one of the small metal-cased loudspeakers used throughout the circulating areas of the station.

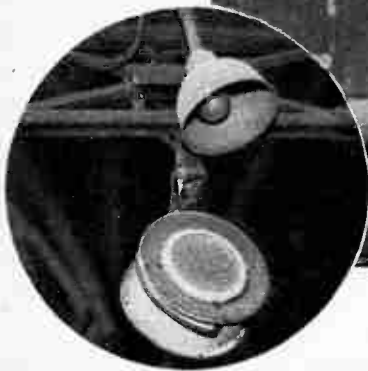

and, thirdly, by varying the power fed to each group of loudspeakers so as to meet changing noise levels by means of the volume control system already mentioned.

The system includes no fewer than 123 loudspeakers, of waterproof construction and resistant to the effects of humidity and sulphur and soot corrosion. They are divided into seven groups covering the platforms, cab rank, circulating area and refreshment rooms. The platforms are served mainly by 51 horn-type loudspeakers suspended on carrier wires at a height of about 15 feet. They are highly directional and localise speech as much as possible to the platform for which it is intended. The circulating areas are covered by 59 small circular metal-cased loudspeakers mounted at frequent intervals at a height of 8-10 feet. The refreshment rooms and enquiry office are served by 13 wooden cabinet loudspeakers.

A multi cell crystal microphone is used for feeding a pre-amplifier, which has three stages of amplifi-

cation and includes a valve voltmeter giving visual indication to the announcer, to assure maintenance of constant level of speech.

for various loudspeaker groups. A spare pre-amplifier is installed in case of failure. Two 85-watt power amplifiers are run in paral-



The indication of the valve voltmeter is independent of the main gain setting of the pre-amplifier, and the individual gain settings

lel, and, should one become faulty, arrangements are made for automatic disconnection of its input and output.

Letters to the Editor

Exit the "Tone-arm" • Carbon Resistor Protection • Why "I" for Current?

Pick-up Arms

THE controversy over the notation for the arm that supports the head of a gramophone pick-up seems no nearer a conclusion.

I am satisfied that the choice must lie between the terms "carrying arm" and "tracking arm." "Arm," without any qualifying adjective is, I think, rather a despairing effort; so also is the reversion "tone arm." The latter is suggested because of the torsional consideration in this long member. Surely if one adopts this outlook one might as well call the head a "sound-box" because of the audible mechanical output and its effect upon buzziness in the treble range. If it is necessary to use a term implying the torsional problems why not use "torsional member"? I do not like this because it is too vague.

I did not originally appreciate Mr. Aldous's attempt to distinguish between the driven recording head and the reproducing head, but I am not certain that this is of fundamental importance. Both systems require an arm to allow the head to track properly; tracking itself, and the question of tracking error, which is an unusual geometrical problem, is common to both.

My objection to "carrying arm" is that it sounds awkward; "tracking arm" does not.

I am rather pleased at the growing æsthetic consciousness amongst engineers and feel that this is an occasion when so little is at stake that the better sounding phrase should be used.

A. C. ROBB.

Upton, Wirral.

[Our correspondent has over-

looked the description "pick-up arm," suggested by R. W. Lowden in our January issue. Both "tracking arm" and "carrying arm" need further qualification in some contexts. "Pick-up arm" is by itself sufficiently descriptive, and so seems to be the best of the names suggested. This correspondence may be closed by saying that, although we may forget the "tone arm" of the acoustic gramophone, we must remember H. Morgan's timely warning (*Wireless World*, February) that tone may still be affected by the pick-up arm.—ED.]

Pity the Author!

WRITERS of textbooks, particularly those concerned with popular sciences such as radio engineering, frequently receive requests for technical information from readers and students. An author is generally very pleased to help in solving technical difficulties, but it seems unfair that he should be expected not only to provide free advice but also to pay for conveying the reply to the enquirer. In my case only one out of a fair sized mailbag has so far remembered that an author (of technical books at least) is not a man of unlimited means. His reply to my thanks for this elementary courtesy is perhaps worth quoting: "Why not include in the preface a reminder that readers who have bought the book have not bought the author?"

This omission of the stamped addressed envelope is probably due to lack of appreciation that the questioner is not the only one writing, and I should be very grateful if you would give this point publicity in your correspondence columns.

AN AUTHOR.

Carbon Resistors

IN my article on carbon resistors, which appeared in the January issue, it was stated that a polyvinyl chloride sleeve was unsatisfactory as a protection against the effects of moisture. This might be misconstrued as a criticism of the resistors made by The Gramophone Company. It may be pointed out that the resistors made by this company are protected against the effect of moisture by means of a lacquer; and

the polyvinyl chloride sleeve is used for mechanical protection only. It is clear that these resistors will not suffer from the defects present in resistors protected by sleeving only.

R. H. W. BURKETT.

Aldershot.

Why "I" for Current?

A QUESTION which has been puzzling me for many years is why the symbol "I" was chosen to represent current in equations and formulæ. May I beg space to ask if any readers can shed light on the origin of this? Was the letter chosen arbitrarily, and if so, by whom? There would appear to be some considerable authority behind it, for did it not cause the mathematicians "i" ($=\sqrt{-1}$) to become a "j" when applied to electrical problems?

Chester.

G. GHERY.

Incidence of Deafness

I SEE no reason why the estimates of Messrs. Lilburn and Balbi should not be equally correct. The question is: what are their respective standards of partial deafness?

Unfortunately, the self-consciousness of the deaf in relation to their affliction is such that they defer enquiry about an aid until the last possible moment. Further, the possibilities of medical aid are commonly so limited, that professional assistance is frequently sought only when it is too late for preventive measures. These factors make the collection of reliable statistics on deafness difficult in normal times.

It occurs to me that the medical files connected with National Registration would give precise information on a nation-wide scale. It is only necessary to find how many men are disqualified from military service on account of their hearing.

Compilation of statistics of persons in Grade IV and, if necessary, of Grade III could surely be made to yield sufficient information of national value to justify a skilled committee's being appointed to do the research and report. Needless to say, the incidence of deafness would be a small part of such an analysis.

Even if complete analysis were not attempted, detailed information on the disabilities of a repre-

sentative cross-section of the community should be obtainable at small enough expense to justify manufacturers of various classes (e.g., manufacturers of remedial appliances, or of foods or medicines) combining to pay for an investigation of their potential market.

JOHN A. HAMILTON.

Glasgow, S.3.

[Although the two estimates quoted were not made on precisely the same basis, there was fairly close agreement as to standards of deafness. The low estimate of 100,000 persons related to those "who need assistance," and the strongly contrasting figure of between four and five millions to those "in need of a hearing aid."—ED.]

Servicemen's Organisation

I NOTICE that at last there is some sort of a plan for a servicing certificate, and now may I suggest that servicemen get together and form their own Institute or Society, and create their own standards?

Radio repairing is a vocation on its own, and it deserves an independent organisation to cater for its own needs.

S. GOLDSTEIN.

R.E.M.E., India.

MURPHY SERVICE INSTRUCTIONS

THE second part of the manual giving alternative valve types which may be used to maintain Murphy receivers in service has now been published. Like Part I, which was mentioned in our August, 1943, issue, it deals with specific models and gives in tabular form the position of each valve in the circuit, together with possible alternatives by Marconi, Osram, Mazda, Cossor, Mullard or Brimar. Where valveholder or circuit modification is necessary, a reference number is given and detailed instructions are to be found, together with valve-base connections, at the back of the book.

The sets dealt with are A36, A38, A40, A46, A48, A50 and A52. The price of Part II of the manual, which is issued by Murphy Radio, Ltd., Welwyn Garden City, Herts, is 1s. net.

"WIRELESS WORLD" INDEX

OUR Publishers announce that the Index for Volume XLIX of *Wireless World* (Jan.-Dec., 1943) is now ready; price 1s. 1½d. by post. A binding case, complete with index, can be supplied at 4s. 10d. by post. Readers' copies can be bound in the Publishers' case, with index, at a cost of 10s. 9d., including return postage.

U.S.A. PLANS POST-WAR RADIO

Plea for a "United Nations Agreement"

By D. A. BELL, M.A.

EARLY in 1943 J. L. Fly, Chairman of the Federal Communications Commission of U.S.A., appealed for proper planning of the change-back of the radio industry from war to peace,¹ and particularly invited the I.R.E. and the (American) R.M.A. to set up a planning committee. Fly expounded the point of view which is now generally accepted: the radio industry has been vastly expanded for the war, and at the end of the war could not be suddenly stopped without causing serious financial and social dislocation. The extent of the problem has since been shown by information released in Washington, that American radio production is now at the rate of \$250,000,000 per month, and for the year of 1944 is scheduled to reach the total of \$4,500,000,000; this is several times the value of the total export trade (all classes of goods) of the U.S.A. in a year such as 1935. In addition to the current capacity of the industry, demobilisation will release numbers of radio mechanics and technicians from the Forces, and there will be large surpluses of components and equipment. No wonder U.S.A. talks of being the "radio factory of the world" after the war. Fly mentioned the possible expansion of the application of radio technique to other fields, such as medicine and surgery, industrial processes and industrial safety, and also urged the improvement of technique of transmission of sound and pictures to foreign peoples so as to establish common ideals among people of goodwill everywhere. But, returning to domestic fields, he pointed out that after the war we may expect a rapid expansion in the latest developments, FM and television, and that, since the broadcast industry is now frozen, there will be a unique opportunity to adopt the most advanced technique now available with less than the usual degree of economic difficulty resulting from the obsoles-

cence of previous standards.

The R.T.P.B.—The American radio interests have responded to this invitation, and have set up a "Radio Technical Planning Board," whose aims are worth quoting; they are "To formulate plans for the technical future of the radio industry and services, including frequency allocations and system standardisation, in accordance with the public interest and the technical facts, and to advise government, industry and the public of its recommendations. Such planning shall be restricted to engineering considerations." The sponsors of the R.T.P.B. are non-profit associations and societies having an important interest in radio. It can also call upon any technically qualified persons for advice, and it appears that in this way commercial firms are represented on the Board through the Board's technical panels; the Board consists of one representative of each sponsor and the chairmen of all the panels. The sponsors present at the first meeting included the A.R.R.L., I.R.E., R.M.A., A.I.E.E., various associations of broadcasters, etc.; Dr. W. R. G. Baker, vice-president of General Electric, was appointed chairman of the Board for one year.

It is only the technical aspects of radio problems which are to be examined by the Board; but in fact it seems inevitable that the technical recommendations must be influenced by the economic background of the questions. The sponsors of the Board are non-profit associations, representing both professional radio institutions such as the I.R.E. and users of radio such as the National Association of Broadcasters; the necessity of avoiding the direct intrusion of commercial interests is obvious, but the practical experience of engineers employed in industry is very valuable, and is apparently brought to the Board through its technical panels. The Board has no powers to secure adoption of its recommendations,

but it is so representative of all radio interests that neither government departments nor private enterprises would be likely to disregard its technical recommendations without strong reasons.

Much is expected of television in the U.S.A., both as an amenity which should be spread nationwide in a short period and as a means of providing useful work for the radio industry after the war; presumably the R.T.P.B. will be asked to give recommendations for the picture standards and for the carrier frequencies to be used, problems which in Britain will have to be considered by the new Television Committee. The R.T.P.B. is in some ways a more suitable body for this job, because one cannot fix carrier frequencies for television without considering frequency allocations for other services. Already a whole series of tentative frequency allocations from 30 Mc/s upwards has been agreed between the F.C.C. and the Civil Aeronautics Administration of U.S.A., for communications, airfield traffic control, course beacons, blind landing gear, etc., and even a transfer to centimetre waves would not give television a clear choice of frequencies.

International Problems.—If the R.T.P.B. is asked to recommend carrier frequencies for television (or any other service), it may give an answer which seems to meet all the technical requirements of U.S.A. services but yet may clash with frequency allocations subsequently made at the next international telecommunications conference. There are two reasons which make it impossible for one nation alone to allocate frequencies to various services. The obvious difficulty arises on the lower frequencies which are capable of long-distance propagation and so interfere with the use of the same frequency in other parts of the world; it is difficult to place an upper limit to the long-distance frequencies, but the sound programme from the London television service was on one occasion received in South Africa, so that

¹ Proceedings of the Institution of Radio Engineers. Vol. 31, p. 33.

the television frequencies may not be immune from international interference. But even on purely optical frequencies some international agreement is necessary. One reason for this was explained in the Editorial of the February *Wireless World*: television might suffer severe interference from radar equipment used for navigation, and besides interference from shipping in coastal districts we might have interference from air navigation in any part of the country near an aerodrome, for surely aircraft will need radio guidance even more than ships. A further reason is that some types of navigational aid will need co-operation between the moving station on ship or aircraft and fixed stations; obvious examples in the case of aircraft are the blind landing systems and radio beams marking courses which are known in U.S.A. as "radio ranges." In such cases there must be international agreement on frequencies to enable aircraft and ships to have equipment which will operate in all parts of the world. Will it be necessary to wait until after the war—perhaps two years or more after an armistice—and call a truly international conference, or will the United Nations draw up a wavelength plan this year? The latter is the only hope if the radio industry is to be converted immediately from war production to the production of civilian requirements in navigational aids as well as broadcasting. Unfortunately, the exact frequencies which have been found most successful for radar are regarded as a military secret, but from the point of view of the design of both broadcasting receivers and navigation equipment the exact carrier frequency is not important,

though some idea of the wave-band is necessary to determine the types of valve and general technique to be used. It would be very useful to the radio industry (and surely not harmful to military security) if a formula of this type could be issued:—

"Somewhere between 40 and 100 Mc/s there will be a band or bands totalling 25 Mc/s in width available for sound and vision broadcasting; between 100 and 500 Mc/s there will be 100 Mc/s for broadcasting, 200 Mc/s for air to ground communication and . . ."

Britain has yet to go as far as U.S.A. in preparing to work out its own radio plans, and this must be our next step. But we must not forget the need for an international agreement on wavelengths; when Britain as well as America has set up machinery for clarifying national requirements, it should be possible for the two countries to call a conference of the United Nations to lay down an international frequency allocation.

RADIO DATA CHARTS

Revised and Expanded

Third Edition

WHEN the last copies of the second edition of this set of abacs by the late Dr. R. T. Beatty were sold it was decided to prepare a completely revised new edition. This was undertaken by J. McG. Sowerby, B.A., who is already known to readers of this journal as the contributor of many new and useful abacs in recent issues.

The total number of charts in the new edition has been increased from 30 to 40 and a set of copper wire tables is also included. In addition to the 10 new charts, 11 of the

original series have been redrawn to extend their range or otherwise to bring them up to date and the text has been revised and rewritten throughout.

Problems covered by the new series include the design of transmission lines, change of coil inductance and RF resistance due to screening, loudspeaker dividing networks, multi-ratio output transformers for supplying simultaneously loudspeakers of different impedances with different powers—and, of course, all the routine work of coil, choke, mains transformer design, etc., which formed the backbone of the original work.

The price of the enlarged third edition, which is issued from the offices of *Wireless World* by our publishers, Hiffe and Sons, Ltd., Dorset House, Stamford Street, S.E.1, is 7s. 6d., or 7s. 9d. by post.

RADIO BRAZZAVILLE

THE story of Radio Brazzaville affords a striking example of the part played by wireless in the war. When France fell this 8-kW telegraphic station in French Equatorial Africa was modified, with the help of purely local resources, for telephony. Although output was reduced to 3 kW, this makeshift broadcast transmitter served as a link between outposts of Fighting France and the Mother-country.

Now, thanks to the installation of high-power RCA short-wave equipment, Radio Brazzaville has become an information centre for the whole of the French Empire. Satisfactory reception in Metropolitan France, her colonies and, indeed, the whole world, is ensured by a multiple directional aerial system. In addition to the broadcast transmission service, there is an extensive monitoring and interception organisation handling 60,000 or more words a month. Africans have been trained in aural morse and slip reading, and Marconi and Boehme undulators are installed for the reception of high speed telegraphy.

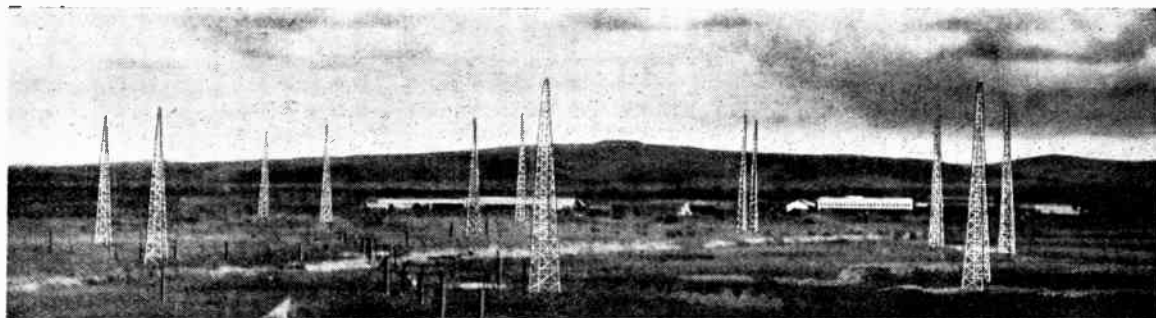

Radio Brazzaville: The six-way directional aerial system provides for beam transmission to the entire French-speaking world, occupied and free. It is supported by 24 130-ft. masts.

Noisy Neighbour Neutraliser

FROM time to time we have read a lot in the pages of this journal about the structure of the human ear and the way in which it functions, and in almost every case the writers of the articles have seen fit to draw attention to what, in their opinion, a wonderful organ it is.

I need hardly say that I profoundly disagree with such an opinion, as in actual fact the ear is one of the few organs of the body in which Nature has slipped up badly. The reason, of course, is that, unlike the eye, which can be closed down at will to shut out something unpleasant, the ear is provided with no movable lid or flap to perform a similar office. The nose too, is one of Nature's failures in this respect. Our fighting men in the not-always-so-gorgeous Middle East will bear me out in this.



"The not-always-so-gorgeous Middle East"

This aural deficiency is very regrettable, as anybody will bear witness who has ever had the misfortune to dwell next-door to anybody addicted to the pernicious and utterly anti-social habit of operating a loudspeaker at full blast with open windows. The constant shifting about of the population due to evacuation, de-evacuation and "direction" by the Ministry of Labour recently resulted in this misfortune occurring to me. An individual addicted to this miserable habit was recently "directed" to come and live next door to me and do something or other, with the result that I received the full benefit of his over-loud speaker. The law is none too helpful in these cases, and I determined to take it into my own hands and put into practice the military maxim that the best form of defence is attack.

By FREE GRID

I, therefore, set about the construction of a super-amplifier feeding a super-loudspeaker, but was soon brought to a halt by the vexing wartime regulations regarding the purchase of valves having a greater output than ten watts. Valves are, however, not a *sine qua non* to audio-frequency amplification, although no doubt this pampered and spoon-fed generation of radio men know nothing of Stentorphone principles and have probably never even heard of Johnsen-Rahbek technique, which depends on varying the adhesion, by application of signal potentials, between the contacting surfaces of a conductor and a semi-conductor.

At any rate the result of my labours has been that I have been able to silence all opposition, for whenever the directee (horrible word) turns up the wick I am able to bring my heavy guns into action and reduce him to impotence. Unfortunately, whenever I switch on there is such a nerve-shattering roar that several people in the neighbourhood have complained to the authorities that they are unable to hear the air-raid sirens and on several occasions the local A.R.P. people have turned out at the double to deal with what they supposed was Adolf's secret weapon. On the other hand several people living a couple of streets away have written to thank me for enabling them to help in the national fuel-saving campaign by turning off their own sets and listening to mine.

Devil's Advocate

LIKE the proverbial Irishman who is always "agin the Government" as a matter of principle, I have always endeavoured to range myself on the side of law and order "agin" both the Editor and the radio manufacturer or dealer, even on those rare occasions when conscience dictated the opposite. A recent letter from a reader has, however forced me to depart from my principles. In this letter he cries aloud for justice and for vengeance against a radio dealer who, so he alleges, is obviously "working a racket" which he desires me to expose.

As is my custom, I have investigated the whole case thoroughly, with the result that I have very reluctantly been compelled to decide

that not only is no racket being worked but, on the contrary, the dealer in question is exhibiting unusual intelligence and common sense.

The facts are simple. My correspondent lives in a DC district and for a long time past AC/DC valves, more especially output valves, have been almost as scarce as bananas, in spite of much that has been said to the contrary. He has been on the waiting list of his local dealer for a special output valve for almost exactly eighteen months and recently received a letter stating that a valve was waiting for him at long last but that the dealer insisted on



"A letter from a reader"

having the set into his shop for overhaul before supplying the goods.

To the uninitiated it seems an obvious case of an unscrupulous dealer, unable to charge more than the official price for the valve, trying to get a "black market" profit by a racket to which I drew attention in these columns in November, 1942. Investigations showed things to be quite the opposite, however. The set in question is one which has been out of action for a full eighteen months owing to the extreme shortage of AC/DC output valves, and since it is of a type which is liberally bespattered with electrolytic condensers, its owner would probably have had very real cause for complaint had he merely inserted the new valve and switched on.

Radio manufacturers had something to say about this point early in the war when we were all putting our television sets into cold storage, but it is as well to remember that a long-disused "ordinary" set is equally vulnerable. There must be many, many thousands of such sets stored away in furniture depositories and suchlike places for the duration of the war, with no possibility of their being switched on every few months to keep the electrolytics properly "formed." I think that manufacturers, or even the Editor, might let a waiting world have a few words of wisdom about what to do before switching on after the last "All clear" has sounded.

Angles on **BRIMAR PRESTIGE**

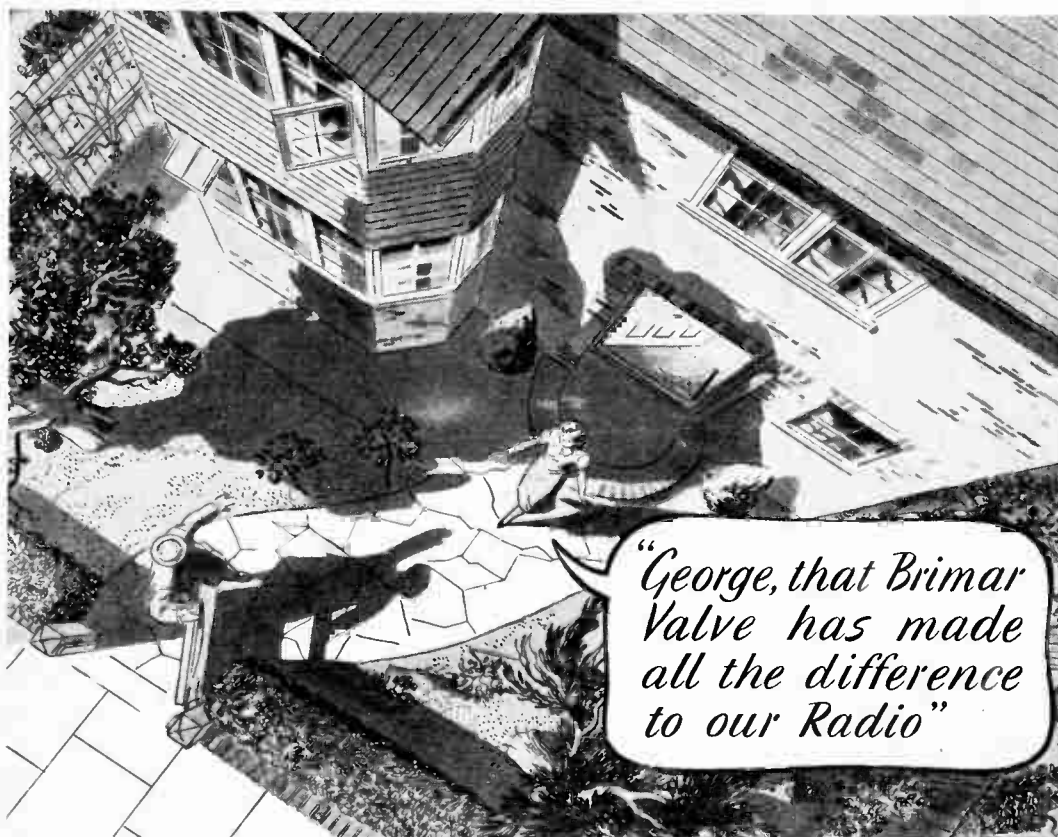

By no means an uncommon result when Brimar Valves are fitted. Engineers are well aware of their close limits and unfailing reliability.

BRIMAR

BVA

VALVES

STANDARD TELEPHONES AND CABLES LIMITED, FOOTSCRAY, SIDCUP, KENT.

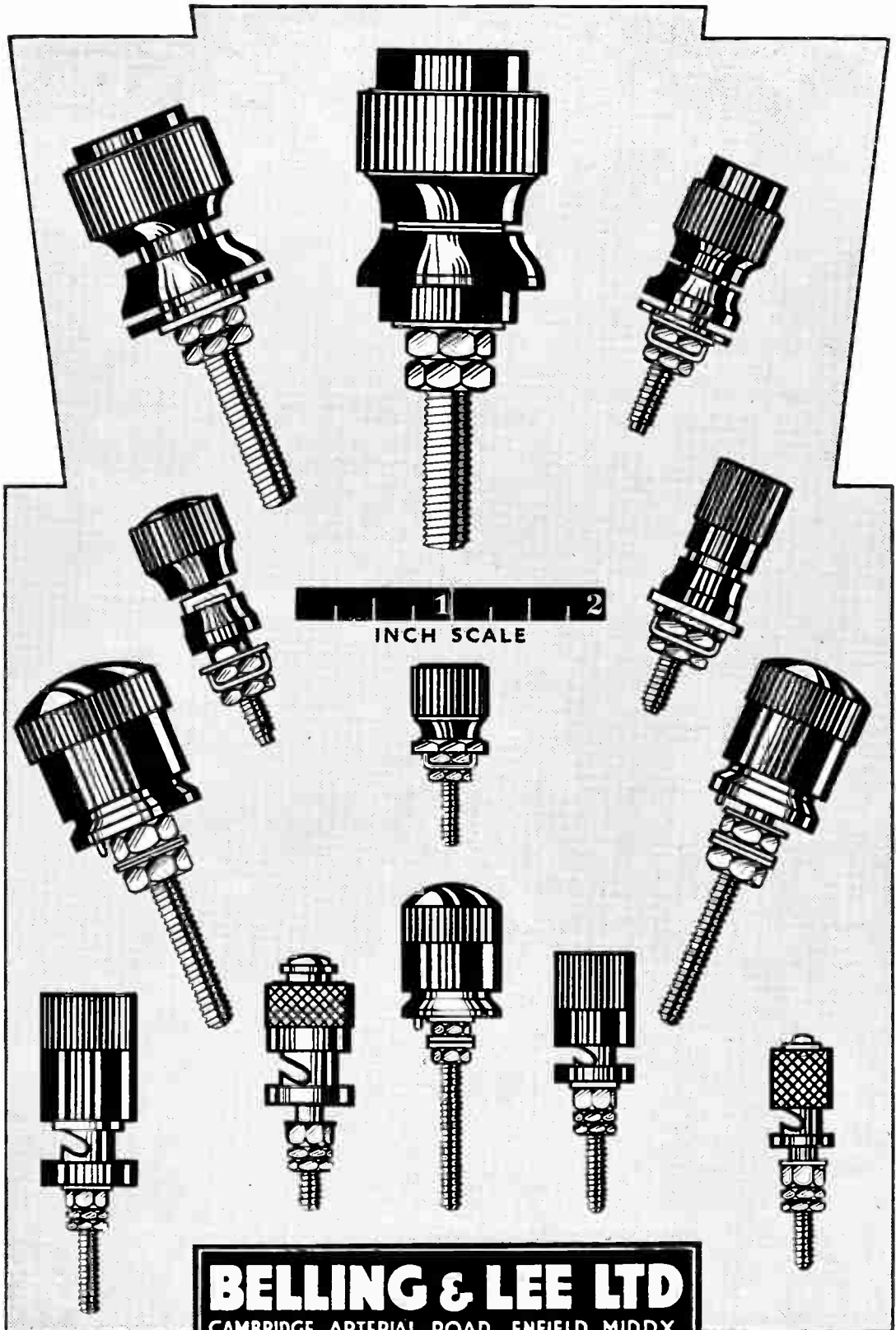

BELLING & LEE LTD
CAMBRIDGE ARTERIAL ROAD, ENFIELD, MIDDX

GA

AIRCRAFT RADIO

A Textbook of Engineering Principles

Reviewed by

CHARLES B. BOVILL

IF, as seems likely, there is to be a great extension of civil aviation after the war, it follows that an increasing number of radio technicians will wish to know more about aircraft radio. The principles underlying that rather specialised application of the art are well set out in a book,¹ written by an American author, which has recently become available in this country. The fact that American aircraft radio practice differs in several important particulars from that of Europe does not greatly lower the value of the book to the English reader, though one feels that some of the problems that arise outside the U.S.A. deserve more detailed treatment; in particular, MF transmission from aircraft should have been mentioned.

The newcomer to aircraft wireless technique, however wide his experience in other fields, will clearly need information on what may be described as the radio characteristics of aircraft; by this expression it is meant to imply the aerial characteristics for transmission, reception and beam work, mounting of VHF aeriels and the behaviour of short waves when used for communication to and from aircraft. As an example, the possibility of using VHF for aircraft work was in doubt when experiments were first made, it being found that the propellers tended to modulate transmission and reception at a frequency which was the product of the propeller speed and number of blades. This phenomenon required a special technique for the positioning of aeriels before its effects could be overcome.

Another characteristic peculiar to aircraft is the low resistance of aeriels at HF which calls for unusual design in the output circuits of transmitters and the input circuits of receivers. This characteristic is the result of the unique condition of the aeriels being associated with an almost perfect

earth and free from sources of dielectric loss.

A further effect exclusive to aircraft wireless is that the range of HF communication is greater with similar apparatus between a ground station and an aircraft than between two ground stations, due to the fact that at normal operational heights the condition is never met where neither ground wave nor ionosphere reflected wave is not received.

Homing Beacons

The author gives extensive treatment to the system of radio ranges, or equi-signal beacons, which are used throughout the U.S.A. for aerial navigation; while the criticism may be made that this system is not of interest to radio engineers in Europe, its principles and specialised technique embrace many problems peculiar to aircraft radio—in particular in its VHF applications. The range system comprises a pair of aerial systems transmitting a figure-of-eight polar diagram of radiation at right angles to one another which are alternately energised by a single transmitter, the one set of aeriels being modulated with the letter A (— —) the other being modulated with the letter N (— ·). The figure-of-eight diagrams overlap every 90 degrees and provide equi-signal zones. The A-N morse characters interlock in these zones, causing a continuous note which is an indication of the correct course, off-course being indicated by either the letter A or N only. From the point of view of simplicity of the aircraft receiving equipment this arrangement has many advantages but suffers from various defects chiefly due to the frequency used, which is normally in the 200 to 300 kc/s band. Waves in this band are susceptible to night effect as well as to changes in the conductivity of the soil over which they travel, the ultimate effect

being that the courses appear to bend.

Owing to the shortcomings of MF ranges a number of VHF types have been built and have yielded promising results. The adoption of VHF for this service was founded on the principle that, owing to the optical paths followed, the waves would be less effected by changes in soil conductivity.

The author puts forward a sound theoretical argument for this assumption, substantiated by results of practical experiments and adds that economically the system is advantageous, the cost of a complete VHF radio range being less than the cost of a single mast of a medium-frequency installation.

The only guidance given by a radio range is directional, and it does not afford any reliable means whereby a pilot can tell his position along the course when flying out of sight of the ground. For many years pilots used a technique of observing the "cone of silence" effect when directly over a transmitter in order to locate its exact position. The effect took the form of a sudden decrease in signal strength when above the range aeriels, due to their coupling to the aircraft aerial being at a minimum. The indication by this method was apparently unreliable and caused several accidents. A series of markers were therefore installed along range courses which indicated specific points such as the beginning and end of a range course. The marking has been found to be effective, and with the present arrangement the markers consist of a small transmitter operating on 75 Mc/s, which cause a horizontally polarised lobe of signal to be transmitted upward; this signal is received in the aircraft and is made to operate a warning light on the pilot's dashboard, thus indicating his position. The author is of the opinion that future installations of this type will be operated on UHF of the order of 600 Mc/s owing to the simplicity with which the necessary polar diagram can be

¹ *Principles of Aeronautical Radio Engineering*. By P. C. Sandretto. Pp. 406 + XIII; 228 figures. Published by McGraw-Hill Publishing Company, Aldwych House, London, W.C.2. Price 24/6d.

Aircraft Radio—obtained when using this frequency. A vertical polar diagram of a 75-Mc/s marker transmitter is shown in Fig. 1.

The aspects of radio telephony transmission to and from aircraft on HF are, needless to say, very completely covered in the book, as this form of communication has been in continual use in the U.S.A. for over 15 years. The standard technique now employed is for equipment to be remotely controlled by the pilot, the stability of transmitters and receivers being assured by crystal control. Circuits of high sensitivity are used in the receivers,

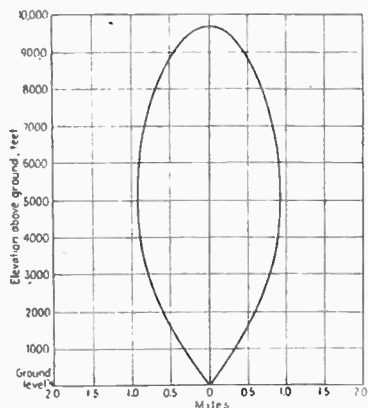

Fig. 1. Vertical polar diagram of a 75-Mc/s "marker" transmitter. The diagrams illustrating this review are reproduced from "Principles of Aeronautical Radio Engineering."

this being made possible by the excellence of modern ignition screening of aircraft engines. The power requirement to give adequate service range varies between 50 and 250 watts. The standard airline communication frequencies are in the 3-Mc/s band for day working and in the 6-Mc/s band for night working.

From the author's description of the apparatus one is led to believe that very skilled maintenance staff must be needed to keep the equipment airworthy, as it is usual to employ complicated electro-mechanical band switching devices.

The extracts from the standing regulations in force relating to airborne apparatus in the U.S.A. are evidence of the robustness and sound design of the various units and of the rigorous treatment which they are expected to receive

under flight, take-off and landing conditions.

It appears likely that VHF radio telephony will eventually supersede HF for aircraft communication work owing to its inherent freedom from atmospheric and in order to relieve congestion of the longer wave bands; it seems logical to suppose that the zonal effect of FM transmission would also be advantageous.

The author outlines the results of some experiments in communication. Vertical polarisation has apparently been found to give the most satisfactory all-round performance, but it has been found difficult to obtain omni-directional polar diagrams of radiation and reception, due to the screening effects of wings and tail units, bearing in mind also that the choice of aerial site is restricted by considerations of propeller "flutter" or modulation.

The author devotes a chapter to airborne DF, and provides useful basic design data and descriptive matter relating to commercially available apparatus, but one feels that more information relative to the practical aspects of the complete aircraft DF installation is required, such as the causes of quadrantal errors. However good receiver design and however efficient a loop may be, the final installation and calibration of aircraft DF is the factor which decides its utility as a navigational aid. A typical quadrantal error curve of a twin-engined monoplane is shown in Fig. 2.

The technique of aircraft DF does not appear to have made any outstanding progress in the past few years beyond refinements to apparatus to simplify tuning and operation and there is no evidence in Sandretto's book of a successful HF or VHF aircraft DF apparatus having been developed.

Ground Clearance Indicators

In order to carry out many essential manoeuvres with an aircraft it is important to be able to determine the distance between the aircraft and the ground below. This information is not given reliably by the normal aneroid type altimeter due to its calibration being in height above sea level.

As a consequence many devices have been projected and tested which measure ground clearance by other than pressure variation

means. The chapter on Absolute Altimeters contains a thorough survey of the subject, Sonic, Capacity and Radio types being described in detail with interesting historical notes. The Sonic types are shown to be ineffective for the reason that there is a change in position of the aircraft between the time that the signal is transmitted and the echo is received back in the aircraft, thus causing an error which becomes progressively worse as aircraft speed increases.

The Radio Altimeter, due to its inherent advantage of the greater speed of travel of radio waves, is shown to be a reliable instrument up to altitudes of 5,000 feet. The underlying principle of this altimeter is to measure the difference in frequency between a signal transmitted from an FM transmitter to a receiver adjacent to it and the signal reflected from the ground, the frequency difference being proportional to altitude.

A less widely known altimeter operating on a capacity principle is described, the basic idea of which is of interest. This altimeter uses two plates suspended beneath an aircraft which have a capacity to each other and to the aircraft; when in close proximity to the ground two other capacities appear, one from each plate to earth and their sum can be considered as a capacity in parallel with the capacities formed by each plate to the aircraft and to each other. The parallel capacity is proportional to the height of the aircraft above ground. The change in capacity per foot is of

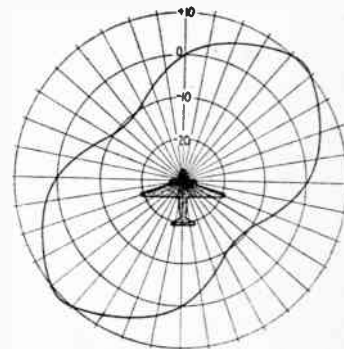

Fig. 2. Quadrantal error curve of an aircraft direction finder.

course extremely small, and according to the author, shows on measurement, with practical sizes of plate a change of only 0.5 $\mu\mu\text{F}$

between heights of ten and one hundred feet. The future development of this type of ground clearance device appears to depend on finding some means of detecting very small changes in capacity.

Radio has been considered for some years as a solution to the difficulties of making landings under conditions of low visibility and a number of systems have been made available commercially. The devices used are in all cases arranged to give course guidance and indication of specific points along the course such as the point at which the descent should be commenced and the point at which the landing runway starts, and in this respect can be considered as miniature radio ranges; the majority of systems also attempt to give guidance in a further plane, the angle of descent. The author states that although many demonstrations have been made, no system has been completely successful in the U.S.A. and the chapter on this phase of aircraft radio is intended more as a summary of the systems which have been tested with a commentary on the results than a source of information relating to the basic principles.

It is apparent that the devices are all satisfactory except for the accuracy of the angle of descent guidance or glide path which tends to be instable and requires too critical handling of the aircraft during the final stages of the landing.

Problems peculiar to aircraft radio engineering which can be described as being outside the basic design and technical principles are grouped under the main heading of Accessories. This section deals with important factors such as noise suppression, aerial facilities required, microphones, telephones and power supplies on aeroplanes.

Hitherto DC supplies only have been generally accepted, such supplies comprising a 12- or 24-volt floating accumulator, or, on the larger aircraft, three or four such independent systems. Attention has, however, lately been turned to the use of AC supplies in aircraft, at frequencies of 400-1,000 c/s. The choice of the higher frequencies was made to enable transformers and chokes of the lowest possible weight to be used. From the radio aspect the use of

AC has many advantages, among them being the avoidance of the necessity for using DC rotary converters with their attendant

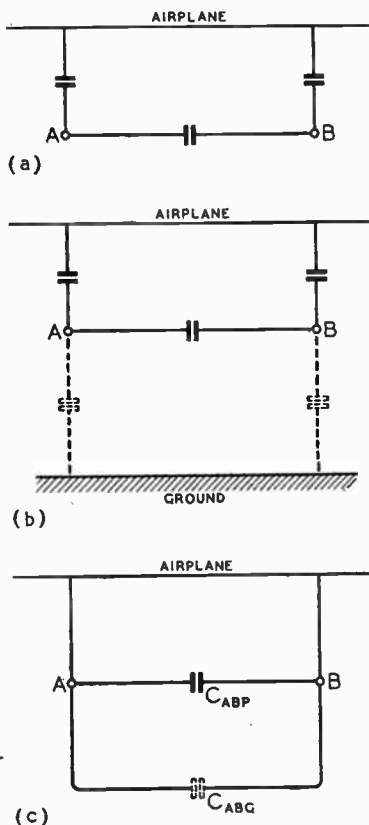

Fig. 3. The capacity altimeter : diagram (a) shows capacities existing between the electrodes when the aircraft is in free space, while (b) shows the extra capacities which come into play as the earth is approached. Diagram (c) represents the electrical equivalent of (b).

weight and maintenance requirements. Some interesting weight comparisons are made in the chapter on aircraft power supply systems which indicate that AC is eventually likely to be adopted generally for transport aircraft. In the aeroplane electrical installation of the future it appears that the prime mover for the power supply will be independent of the aircraft engines and will be in the form of a petrol-driven generator, this being necessary for reasons of frequency stability and to counter the possibility of electrical failure as the result of an engine stopping.

A series of drawings showing standardised sizes of cases and

mountings for radio equipment are included in the Appendix which show that liaison exists in America between manufacturers of radio equipment and aircraft. In Europe until the outbreak of war it was not unusual for structural modifications to have to be made to aircraft to accommodate the required ratio apparatus.

In conclusion it can be said that Sandretto's book will have a wide appeal to technicians, in fact to all associated with aircraft radio problems, including installation engineers, and it can be regarded as a standard text book of reference upon the technique of aircraft radio engineering.

AUSTRALIAN PIONEER

IN appreciation of the services Sir Ernest Fisk has rendered in Australasia in the field of radio communications the Council of the Institution of Electrical Engineers has elected him an Honorary Member of the Institution.

Sir Ernest is a Past President of the Institution of Radio Engineers (Australia) and Chairman of Amalgamated Wireless (Australasia) and several other companies concerned with wireless. He joined the English Marconi Company in 1906, and before going to Australia in 1910 was engaged in operating



Sir Ernest Fisk.

and development work in various parts of the world. In 1913 he assisted in the formation of Amalgamated Wireless of Australasia, and since then has played a prominent part in antipodean wireless.

RADIO DATA CHARTS—15

IF Transformer Design

By

J. McG. SOWERBY,

B.A., Grad.I.E.E.

(By permission of the Ministry of Supply)

BASICALLY the IF transformer consists of two tuned circuits coupled to one another inductively, capacitatively, or by a combination of both. To obtain high amplification it is usually desirable that the dynamic resistance of the tuned circuits be high, since they will normally be used as the anode loads of pentodes or tetrodes where the gain is nearly proportional to the load. Since $R_D = L/Cr$ where r is the RF resistance of the coil, it follows that for a high R_D , C must be small and the ratio L/r (or $Q = \omega L/r$) large. A limit to the Q of the coil is imposed by considerations of convenience, and a figure of 300 is rarely exceeded, values usually falling within the range 50 to 150. A limit to the reduction of C is set by variation of the valve capacities with changing AVC bias which must be swamped by C . Thus C usually falls within the range 100 to 300 $\mu\mu\text{F}$ according to circumstances, and L is made to resonate at the desired intermediate frequency.

Fig. 1 shows a typical inductively coupled IF transformer

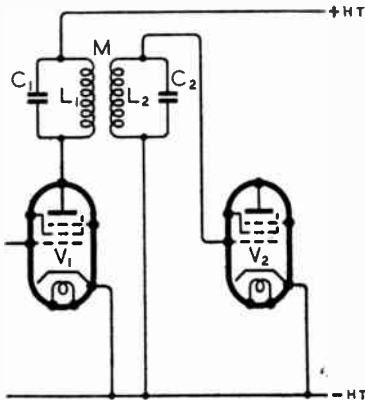

Fig. 1. Typical IF transformer-coupled stage.

whose primary L_1C_1 is identical with its secondary L_2C_2 , so that the Q of the two tuned circuits is the same. If g_m is the mutual conductance of V_1 then the gain of the stage may be written:

$$A = g_m |Z| \quad \dots \quad (1)$$

where $|Z|$ is the transfer impedance, and the anode resistance

of V_1 is very high compared with $|Z|$. This gain is the ratio of the output voltage at the secondary terminals to the input voltage at the grid. At the IF to which both L_1C_1 and L_2C_2 are tuned, the transfer impedance may be written:

$$|Z| = \frac{R_D Qk}{1 + (Qk)^2} \quad \dots \quad (2)$$

where R_D is the dynamic resistance of one tuned circuit isolated from its fellow, and k is the coupling coefficient.

$$k = M/\sqrt{L_1L_2} \text{ or } k = M/L \text{ if } L_1 = L_2 = L \quad \dots \quad (3)$$

where M is the mutual inductance between the windings. If $k = 1/Q$ so that $Qk = 1$ the coupling is said to be critical, and $|Z|$ is at a maximum and is simply $R_D/2$.

Since the gain is proportional to the transfer impedance $|Z|$ —equation (1)—then a curve showing the variation of $|Z|$ with frequency would represent the selectivity characteristic. Such a selectivity curve may be drawn for any given pair of coupled circuits and at critical coupling it is found that the curve is approximately flat topped. As the coupling is decreased (Qk less than 1) a single peak at the IF is obtained and the maximum $|Z|$ falls below $R_D/2$. As the coupling is made greater than critical (Qk greater than 1)—sometimes called overcoupling—two peaks appear symmetrically on either side of the IF and the impedance at these peaks is again $R_D/2$. Fig. 2 (a) shows the overcoupled condition, and (b) shows the curve for coupling less than critical. These curves apply only to one particular pair of coupled circuits, but it has been shown by R. T. Beatty (*Wireless Engineer*, Oct. 1932, p. 546) that they can be cast in universal form to cover all identical pairs of coupled circuits. This is done by plotting the logarithm of the ratio of $|Z|$ to

$R_D/2$ (which is always the maximum) against $2Q\Delta f/f$ where Δf is the detuning and f is the intermediate frequency; the ratio scale is then marked off in decibels for convenience. Such curves have been plotted for various values of Qk both greater and less than critical and are shown on the universal selectivity chart presented here. Only half the complete curve has been plotted since it is symmetrical.

In practice it is troublesome to have to calculate $2Q\Delta f/f$ for every value of Δf in order to plot a selectivity curve for a given pair of coils, and so an abac has been superimposed on the selec-

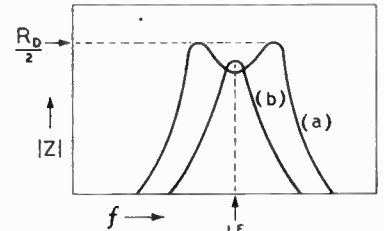
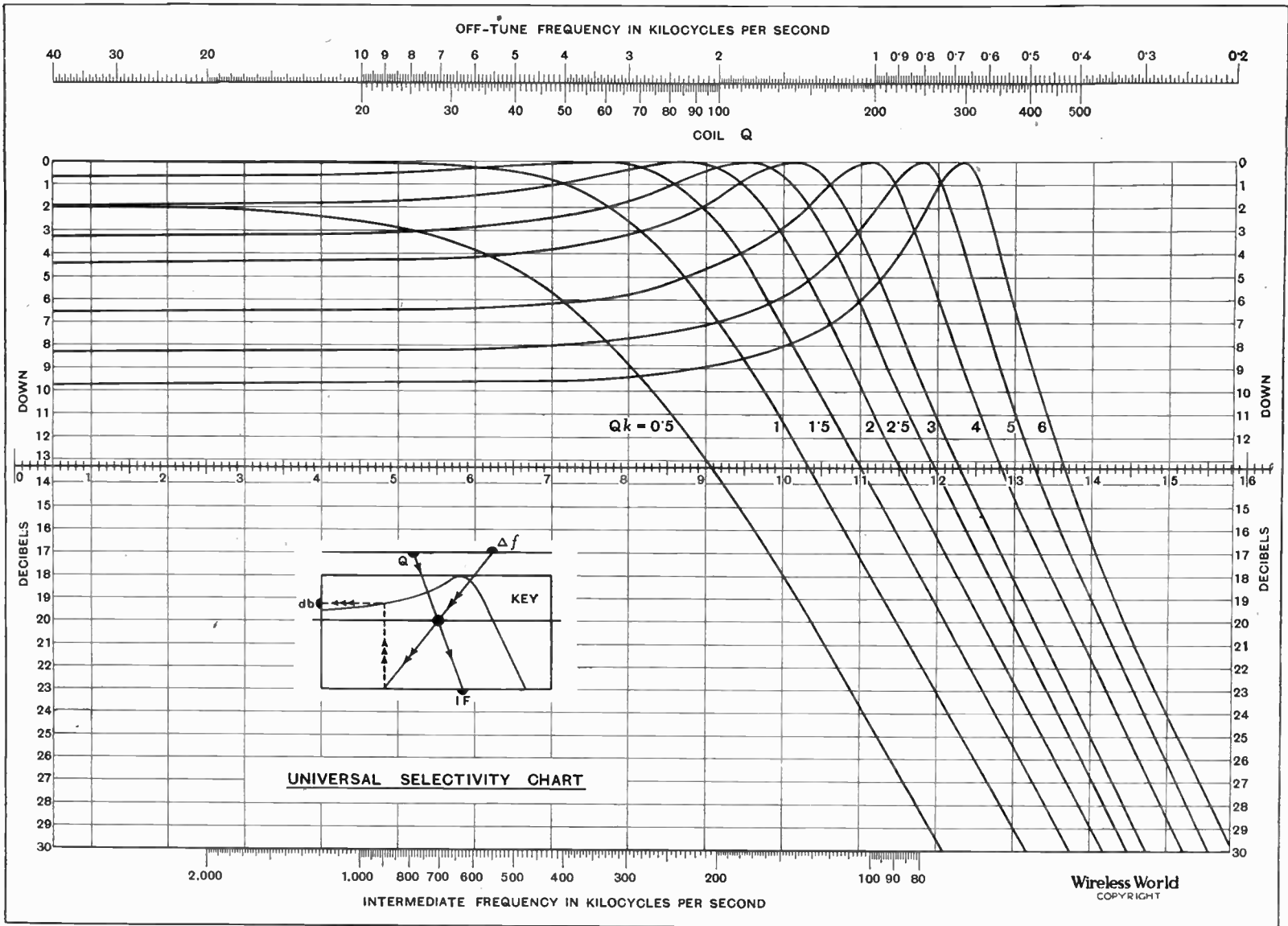
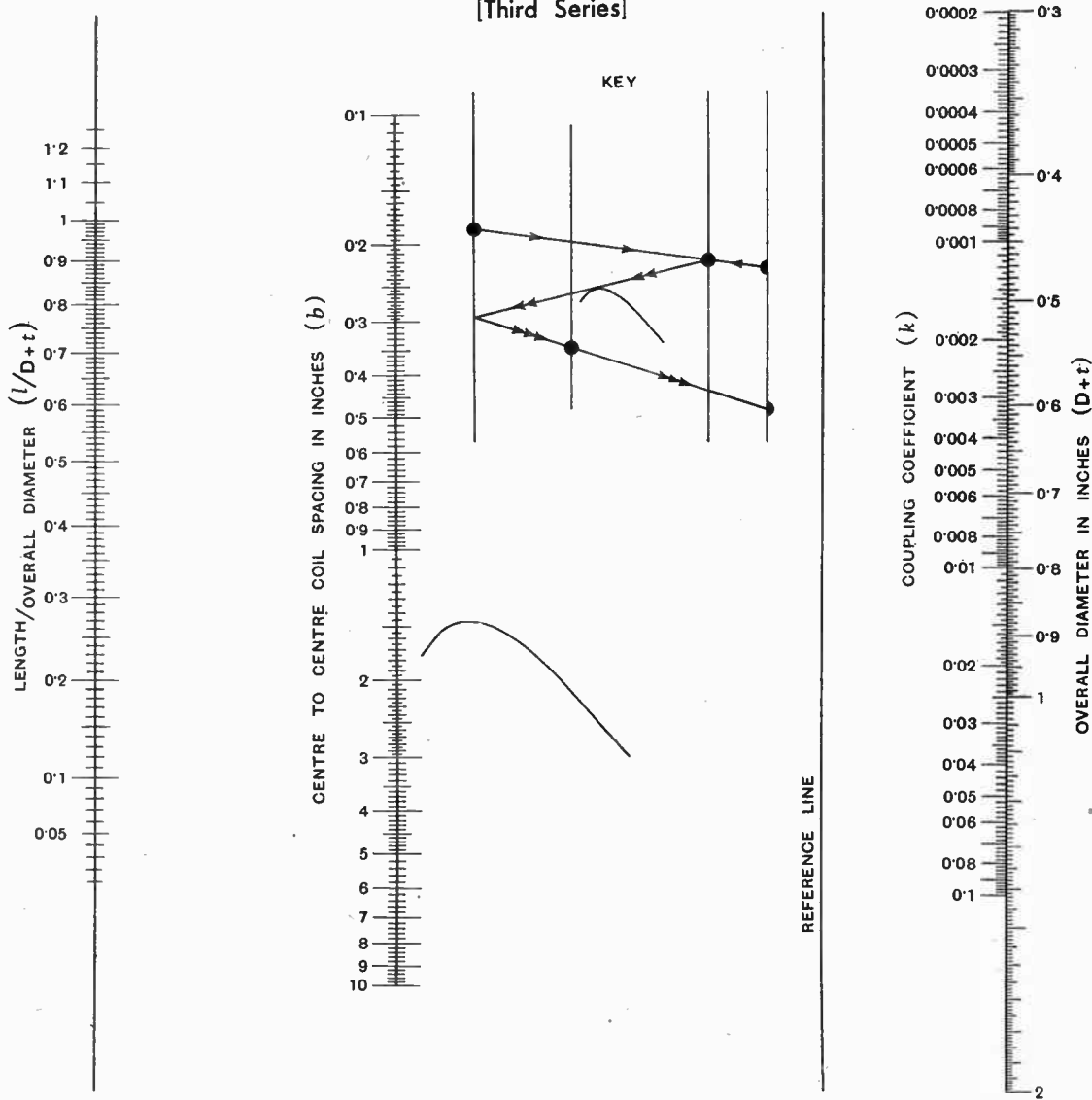

Fig. 2. Response curves (a) with more and (b) with less than critical coupling.

tivity curves to perform this calculation. It is simple to handle, as will be seen from the key and from the example. By means of the chart an entire selectivity curve may be laid off from a number of points calculated by the chart in quite a short time. It is worth noting that the equation on which the curves are based requires some simplifying assumptions for its derivation which means that the curves are accurate enough at an IF of 450 kc/s or more, but that at 100 kc/s or less too much reliance should not be placed on figures for large detuning. Readers requiring a fuller exposition of the derivation of the curves and their utilisation are referred to R. T. Beatty's paper mentioned above or to *Radio Receiver Design* by K. R. Sturley (1st Ed. Chapman and Hall, pp. 295 to 303). Information concerning the use of the chart with pairs of dissimilar circuits is given by (Concluded on page 85)



ABAC No. 15
[Third Series]



COUPLING COEFFICIENT OF IF TRANSFORMERS

Wireless World
COPYRIGHT

Radio Data Charts—15—

K. R. Stutley (*Wireless Engineer*, Sept. 1943, p. 426).

Example 1.

Two identical tuned circuits ($Q = 100$) working at an IF of 450 kc/s have a coupling coefficient equal to 0.02 so that $Qk = 2$. What is the attenuation at 2, 3, 5, and 10 kc/s off tune?

Following the key, join $Q = 100$ to $f = 450$ kc/s giving a point on the reference line. Swivelling about this point read off the decibels down on $Qk = 2$ curve using the values of 2, 3, 5, and 10 kc/s on the top scale. At these frequencies the response is 1.15, 0.34, 0.91, and 12.7 decibels down respectively. Note that if two such transformers were used in successive stages the response would be twice the number of decibels down at the selected frequencies off tune. If the stages are not the same the individual decibels down should be added to give the overall response.

From the universal selectivity chart the required response curve may be chosen, and hence the desired coupling coefficient. This is obtained in practice by placing the coils L_1 and L_2 of Fig. 1 coaxially on the same former the correct distance apart. If the coils are identical then the relation between their spacing (b) and the coupling coefficient

required k is 0.02 ($Q = 100$, $Qk = 2$); the dimensions of the coils are as follows: $D = 0.8$ in., $t = 0.3$ in., and $l = 0.2$ in. What is the requisite spacing (b)?

First find $l/(D + t)$. This is $0.2/1.1 = 0.1818$. Join this point to $k = 0.02$ giving a point on the reference line. From this point draw a tangent to the curve on to the $l/(D + t)$ scale, and join this point to $(D + t) = 1.1$. The ruler now cuts the spacing scale at the answer—1.5 in. nearly—at any rate within the accuracy of the formula.

It is worth noting that the inductance of the coils may be found with the aid of "Radio Data Charts" by R. T. Beatty

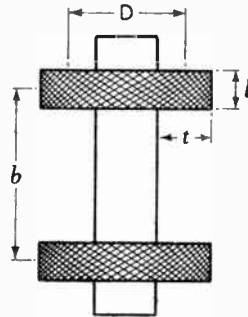

Fig. 3. Symmetrical IF transformer for which the distance b between coils can be calculated for any given coupling coefficient k .

and that M may be calculated for a given spacing between the

$$(k) \text{ is } b = 0.4375(D + t) \left\{ \sqrt[3]{1 + \frac{2.3l}{D + t}} - 1 \right\} \text{ approx.} \quad \dots \quad (4)$$

where all the dimensions are in inches, and the nomenclature is shown in Fig. 3. This formula is due to S.W. Amos (*Wireless World*, Sept. 1943, p. 272) who claims it to be accurate within about 4 per cent. for practical coils. It is now only required to find the correct spacing for the desired k with the given coils from this formula and the design of the IF transformer is complete. An abac has therefore been drawn to cover equation (4) which is given here. The use of the abac should be quite clear from the key and the abac may be read as accurately as the formula warrants. An example follows.

Example 2.

Continuing Example 1, the

notes roughly in alphabetical order, but as there is no index and many of the figures and their captions are without a definite title it is not always easy to find the information required. Thus one finds "Recommended design and constructional details of a wooden studio recording console" between a table of decibels and a series of "equaliser" (tone control) circuits.

Incidentally, the term "equalisation" is defined later as "the logarithmic progressive increase in amplitude of the highest frequency that it is desired to record, from the outside to the inside of a record," and throughout the book there is ambiguity as to the sense in which this term is employed. Unfortunately this is not an isolated example, and one is continually being brought up short by loose and in some cases inaccurate definitions.

While the book cannot for this reason be recommended to student beginners, those with a grounding in the subject will easily avoid the pitfalls and even the "professional recordist" cannot fail to find a fair measure of new and useful information. For instance, there is a full list of the recommendations for standards of electrical transcription recently issued by a Committee of Broadcasters in America, and the bibliography containing 207 selected references to literature on recording is alone worth the money. The table of direct disc recording defects, with their symptoms, causes and cures, is valuable, as is the table of recording blank types with suggested methods of manufacture for amateurs.

Some typographical errors were detected, but these are covered by an Errata and Addenda sheet which the author informs us can be obtained by sending a stamped addressed envelope to him, c/o B.S.R.A., "Strathdee," Studley Road, Torquay. F. L. D.

FARADAY MEDALLIST

FOR his outstanding contributions to electrical science, Dr. Irving Langmuir, whose work on hard vacuum valves, thyratrons, and gas-filled incandescent lamps is well known, has been awarded the Faraday Medal.

This is the twenty-second award of the medal, which is presented by the Institution of Electrical Engineers not more frequently than once a year either for notable scientific or industrial achievement in electrical engineering or for conspicuous service rendered to the advancement of electrical science without restriction as regards nationality or membership of the Institution.

BOOK REVIEW

Manual of Direct Disc Recording, by D. W. Aldous. Pp. 49. Figs. 36. Published by Barnards (Publishers), Ltd., The Grampians, Western Gate, London, W.6. Price 2s.

THE author is well known as a collector of information on disc recording, and in this handbook he has given a very generous helping from his unique fund of knowledge. To pack as much information as possible into 49 pages the author has dispensed with a continuous text and has arranged his

MATCHING

III.—Transmitter Aerial Couplings

THE problem of securing efficient transfer of power from the final closed tuned circuit (tank circuit) of a transmitter to its aerial is simpler, in some respects, than the corresponding problem in receivers. For example, in transmitters one is concerned generally with a single carrier frequency rather than a range, and the need for selectivity in the tank circuit is not so pressing as in receivers. In fact, great adjacent channel selectivity here is undesirable, for a substantially flat characteristic is required to give good transmission of sidebands. On the other hand, considerable rejection is wanted at multiples of the carrier frequency to suppress radiation of harmonics. Complications are introduced, however, by the fact that transmitting aerials are some distance away from the main building, so that the transfer of power has to take place along a twin-wire transmission line (feeder) or a coaxial cable.

By S. W. AMOS,
B.Sc. (Hons.), Grad.I.E.E.

one has first to match the load of the output stage of the modulated RF amplifier to the characteristic impedance of the cable and then the resistance of the aerial has to be transformed into a suitable value for terminating the cable. Now the dimensions of the transmitting aerial are likely to be small compared with the wavelength radiated, which means that the aerial is capacitive and may thus be represented, as before, by a condenser c in parallel with a resistance R_p . It is possible by placing a reactance across this circuit to transform the apparent resistance of the aerial into another value. In Fig. 1 the added reactance takes the form of another condenser C , and we will choose its value so that the aerial resistance appears to be the value of the characteristic impedance of the cable. We have thus satisfied

see that the windings of L are sufficiently thick to carry safely the rather large currents common in high-powered transmitters and C should have an insulation resistance capable of withstanding for long periods the 20,000 volts likely to be found at the base of a medium-wave aerial.

At the transmitter end of the cable we have an example of pure resistive matching, for the output tuned circuit is clearly resonant at the frequency we are concerned with and so behaves as a pure resistance of value $L^2\omega^2/R_2$, where R_2 is the RF resistance of L_2 . A transformer circuit can thus be used as shown in Fig. 1, but it would almost certainly be wound in such a way that the symmetry of the output circuit is preserved. This is not indicated in the figure.

One point should be appreciated here. If all the coupling components are free from power dissipation, i.e., are pure reactances, then all the power generated in the output stage must necessarily go into the aerial no matter what the value of those reactances. But the output valves will only deliver their maximum power when they are "looking into" their correct load resistance, and this can only be obtained by choosing and using the correct value of matching reactances.

We will now consider the problem of aerial matching on short waves, for the problem here is somewhat different from the foregoing, as we shall see. It is convenient when transmitting on short waves to make the radiator one or more half-wave dipoles as the dimensions are convenient. Each dipole, being resonant at the frequency for which it is designed, behaves as a pure resistance of 80 ohms approximately so that the problem of securing maximum radiation from the aerial array is one of matching the comparatively high optimum load of the output valves to the low resistance of the aerial *via* a transmission line. It is customary with short-wave transmitters to use twin wire feeders, and one method of aerial matching using such a feeder is illustrated in Fig. 2. Both output

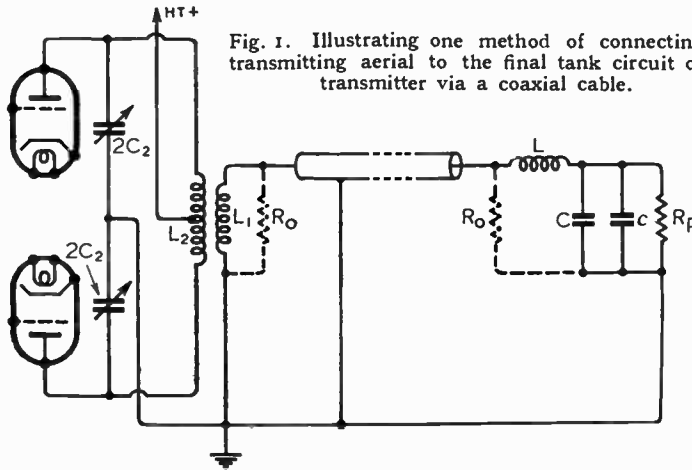

Fig. 1. Illustrating one method of connecting a transmitting aerial to the final tank circuit of a transmitter via a coaxial cable.

As an example of the problems that need to be solved, let us consider the case of a high-power medium-wave transmitter, which uses a coaxial cable as a link. It has been mentioned earlier that for successful transmission along lines they need to be terminated at both ends in a resistance equal to their characteristic impedance. This requires the use of two impedance-matching devices, for

matching equation (1) that $R_l = R_c$. We now need to neutralise the effective reactance of the aerial system, which we can do by adding an inductance L as shown in Fig. 1. Some readers will recognise this is the circuit of the L-type network. In Fig. 1 R_0 is a fictitious resistance representing the characteristic impedance of the coaxial cable.

Practically, it is important to

circuit and feeder are balanced, and so to preserve the balance the feeder is connected to two tapping points symmetrically disposed about the middle of the tank

resistance is 80 ohms. Hence the characteristic impedance of the quarter-wavelength of feeder AB is given by—

$$R'_0 = \sqrt{80 \times 500} = 200 \text{ ohms.}$$

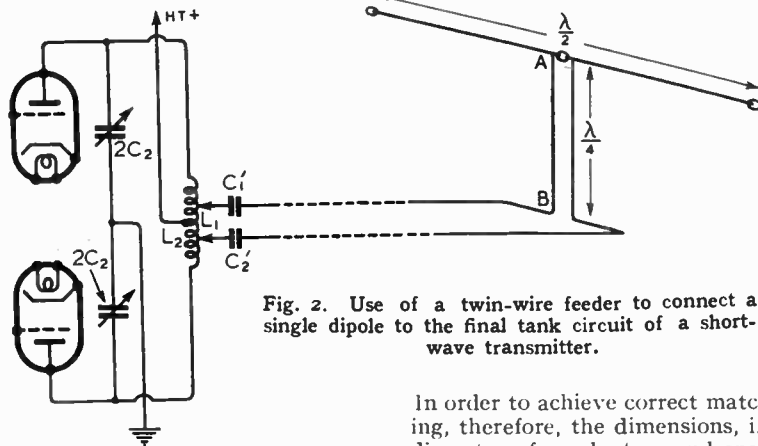

Fig. 2. Use of a twin-wire feeder to connect a single dipole to the final tank circuit of a short-wave transmitter.

tuning inductance, as shown in the diagram. C'_1 and C'_2 are included to isolate the feeder from the HT supply. If R_{opt} is the optimum plate to plate load of the output stage and R_0 is the characteristic impedance of the feeder, then the condition for maximum power transfer is—

$$\frac{1}{k^2} \frac{L_2}{L_1} = \frac{R_{opt}}{R_0}$$

The value of k will depend on the design of the tank tuning inductance, but it is unlikely to differ greatly from unity. The value of R_0 will depend on the physical dimensions of the feeder, but will lie between 400 and 800 ohms in practice. Suppose in a particular case R_{opt} is 5,000 ohms and R_0 is 500 ohms. If the value of L_2 is $20\mu\text{H}$, then from the above equation, L_1 will need to be $2\mu\text{H}$ for correct matching.

A quarter-wavelength of feeder has the property that it will accurately match two resistances R_1 and R_2 connected across its ends provided that its characteristic impedance R'_0 is the geometric mean of R_1 and R_2 , i.e., provided $R'_0 = \sqrt{R_1 R_2}$. In Fig. 2 the impedance transformation at the aerial itself is achieved by means of this property. R_0 is 500 ohms and the aerial

In order to achieve correct matching, therefore, the dimensions, i.e. diameter of conductors and spacing between them, of the feeder AB are then chosen to have this particular value of characteristic impedance.

In conclusion the author hopes that this brief series of articles has done something towards showing that the principles of matching are more universal in their application to radio problems than is generally supposed.

METROVICK "LO-VOLT" SOLDERING IRON

THE iron illustrated is one which was designed originally for use in the Metropolitan Vickers Electrical Co.'s works, but is now being made for sale. As its name implies, it is of the low-voltage type, and with 10 to 12 volts has an operating temperature of 290 to 360 deg. C., with corresponding consumption of 25 to 36 watts. A standby loading of 16 watts with 8 volts on the heater is recommended. The shank is of stainless steel, and the heating element and the copper tip are both replaceable.

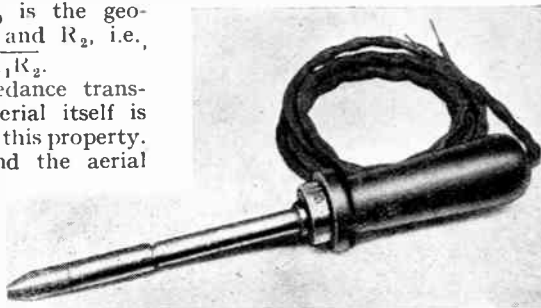

The overall length of the "Lo-volt" iron is $8\frac{1}{2}$ in., and it weighs $3\frac{1}{2}$ oz.

GALPINS

ELECTRICAL STORES

"FAIRVIEW,"
LONDON ROAD, WROTHAM,
KENT.

TERMS: Cash with Order. No C.O.D.
All prices include carriage or postage.

- RESISTANCE MATS**, size 8in. by 6in., set of four 80, 80, 150 and 600 ohms, carry $\frac{1}{2}$ to $\frac{1}{2}$ amp. Set of four, 5/-.
- MOTOR-DRIVEN PUMP**, for oil or water, motor 220v. D.C., 1 amp., 1,250 r.p.m., maker Keith Blackman. 26 10s.
- MASSIVE GUNMETAL WINCH**, complete with long handle, for use with $\frac{3}{16}$ in. dia. wire cable, weight 50 lbs., condition as new. 23.
- ELECTRIC LIGHT CHECK METERS**, well-known makers, first-class condition, electrically guaranteed, for A.C. mains, 200/250 volts 50 cy. 1 phase 5 amp. load, 11/- each; 10 amp. load, 13/6.
- SOLID BRASS LAMPS** (wing type), one hole mounting, fitted double contact, S.B.C. holder, and 12 volt 16 watt bulb. 3/6 each, or 30/- per doz.

WANTED

If any reader has Price Lists or Catalogues of Radio and Electrical Goods I would greatly appreciate them to replace those lost in removal. Postage or cost willingly refunded.

- TUNGSTEN CONTACTS**, $\frac{3}{16}$ in. dia., a pair mounted on spring blades, also two high quality pure silver contacts, $\frac{3}{16}$ in. dia., also on spring blades, fit for heavy duty, new and unused. There is enough base to remove for other work. Set of four contacts, 5/-.
- ROTARY CONVERTER**, D.C. to A.C. Input 22 volts D.C. (twenty-two). Output 100 volts at 140 M/A, 50 cycle, single phase, ball bearing, in first-class condition, no smoothing. 23.
- MOVING COIL AMPMETERS**, 2 1/2 in. dia., panel mounting, modern type by famous makers, range 0- $\frac{1}{2}$ amp. (F.S.D. 10 M/A), 25/-.
- ROTARY CONVERTER**, D.C. to D.C., input 24 volts D.C., output 1,000 volts 250 M/A, choke and condenser smoothing fitted to both input and output, condition as new, weight 80 lb. 210.
- RESISTANCE UNITS**, fireproof, size 10 x 1 1/2 in. wound chrome nickel wire, resistance 2 ohms to carry 10 amps. 2s. 6d. each.
- TRANSFORMER**, size 7 x 9 x 5 1/2 in., 56 lbs., double wound, 230 v. to 40 volts at 1,000 watts. 25.
- AMPMETER**, switchboard type, 6in. dia., for AC/DC, one reading 0-300 amps., one reading 0-100 amps., either meter 50/-.
- VOLTMETER**, switchboard type 8in. dia., for AC/DC reading 0-50 volts, 50/-.
- BLOCK CONDENSERS**, Mansbridge type, paper, 8 M.F., 250v., 5/-; 4 M.F., 750v., 4/-; 4 M.F., 300v., A.C., 4/6; 2 M.F., 250v., 15/- per doz.
- ELECTROLYTIC condensers**, 2,000 M.F., 12v., 7/6; 2,000v., 25v., 7/6.
- TRANSFORMER**, 400v., 3-phase to 230v., single phase, size overall 18 x 16 x 8in., weight approx. 2 cwt., 5 K.V.A., 215.
- MOVING COIL METERS**, all 2in. dia. and flush mounting; a few only. 0-10 M/A, 40/-; 0-150 M/A, 37/6; 0-25 M/A, 50/-; 0-5 M/A, chipped case, 45/-; 0-5 amps, 30/-; 0-10 amps, 30/-; one only 3in. scale, panel, 3 range, 0-15 amps, 0-30v. and 0-150 volts, 55/-.
- TRANSFORMER** cores will rewind for a 1 kW. auto. present windings not guaranteed, 22/6.
- RECTIFIERS**, metal, H.T. 0, 300v., 60 M/A, 15/-; H.T. 10, 200v., 100 M/A, 17/6; W6, 5/-; type 120, 15/-; L.T. 4, 6v., 1A, 10/-; A4, 9v., 2 amps., 30/-; large type output approx. 100v.- $\frac{1}{2}$ amp., 20/-.

WORLD OF WIRELESS

TELEVISION COMMITTEE

AS reported in last month's issue, the Government has appointed a committee to consider and make recommendations as to the development of television after the war. The members of the committee, of which Lord Hankey is Chairman, are: Sir Noel Ashbridge and Robert Foot, B.B.C.; Sir Raymond Birchall and Colonel Sir Stanley Angwin, Post Office; R. P. J. Harvey, Treasury; Sir Edward Appleton, Department of Scientific and Industrial Research; and Professor Cockroft, Ministry of Supply.

J. Varley Roberts (G.P.O.) is the Secretary.

It will be seen that a number of the members sat on the original Television Advisory Committee of which Lord Selsdon was Chairman.

It is, perhaps, significant that the B.B.C. has recalled from its North American Office Gerald Cock, who was Director of Television from 1935 until the outbreak of war.

MORE TELEVISION COMMITTEES

FOLLOWING on the Government appointment of a committee to consider and report on the future of television comes news of the setting up of two new committees. They have been formed with the support of the Radio Manufacturers' Association and the Radio Industry Council, and both are under the chairmanship of C. O. Stanley.

The Television Policy Committee's function is to consider means of re-starting the service and to assist the work of the Government committee and other official bodies by offering advice and submitting information, data, and the views of the industry. The Television Commercial Development Committee, on the other hand, is essentially a body working within the industry itself, seeking to unify the activities of the various sections.

SETS AND COMPONENTS

WHEN asked about the distribution of the new "standard" sets the President of the Board of Trade stated that both the imported lend-lease sets and the wartime standard sets would be distributed to retailers on the basis of pre-war trade. It is understood maximum prices for these sets will be announced very shortly.

Asked once again if he would cause the supply of valves and components to be increased in order that sets now out of commission might be brought into service, Mr. Dalton said that supplies of many types of valves for civilian

use were adequate but some special types were in short supply. In view of the very heavy Service demands, he regretted that he could not hold out any hope of an early increase. He further stated that larger quantities of components were available for civilian sets than last year.

LICENCE FEES

"IF the B.B.C. is to maintain a high standard after the war and keep pace with technical developments the question would inevitably arise whether the existing licence fee of ten shillings a year is adequate." This reply was given by the Minister of Information to a Member of Parliament who asked whether the continuance of the present licence fee, which was fixed many years ago, was adequate to produce high-class programmes.

It was pointed out that since the outbreak of war payments to the B.B.C. had not been related to the revenue from wireless licences. Instead, the B.B.C. received an annual grant-in-aid to cover all its services, including broadcasts to troops abroad.

THE LATE COLONEL OZANNE

IT is with regret we announce the death, on February 12th, of Colonel Guy D. Ozanne, M.C., M.I.E.E., at the age of 54. Until the beginning of the war he was with Wingrove and Rogers, whom



he joined in 1926. During the war he had been undertaking special duties for the War Office. Well known and popular in the industry, he had served as Chairman of the Radio Component Manufacturers' Federation and was on the Council of the R.M.A.

Colonel Ozanne served in the Indian Army from 1909 to 1923 and was O.C. City of London Signals from 1930 to 1935.

SERVICE RECORDING

IT has recently been made known that a scheme for providing radio entertainment for the Forces in all theatres of war, by means of recordings rediffused from local transmitters, has been in operation for more than eighteen months.

Many hundreds of programmes of all kinds have been recorded for distribution to about forty different broadcasting centres in such places as Iceland, Madagascar, Algiers, and Tunis, by this Overseas Recorded Broadcasting Service, as it is called. These recordings are made at the H.M.V. and the Decca Studios in St. John's Wood and Brixton, where activity is even greater than in normal times, although the output of new commercial records is so restricted.

Each of the three Services has its own Radio Production Unit, for the purpose of using the talents of the many recording and broadcasting personalities now in the Forces, and all these recorded programmes are devised and performed by Service men and women.

RECORDING U.S. TRANSMISSIONS

IT may not be generally known that, in compliance with a regulation of the Federal Communications Commission, all programmes radiated by American international broadcasting stations are recorded for reference purposes. It has been found that 16in. discs, permitting an hour's programme to be recorded on each side, are preferable to film recording, which could accommodate a day's transmissions on one reel. The main reason being the ease with which a programme can be referred to.

The audio input to the recording equipment is obtained from RF monitors (demodulated RF) and not from the audio input channels. This ensures a recording of the actual transmission.

B.B.C. FORCES PROGRAMME

WHAT are announced as two self-contained and contrasting services will be available for British listeners from February 27th, when the B.B.C. introduces the General Forces Programme, which will be broadcast from 0630 to 2300 (BST) on two medium and many short wavelengths. The present Forces Programme, which was introduced for the B.E.F. in France in February, 1940, will be discontinued.

The General Overseas Service, broadcast on short waves only, was introduced in June last year for British men and women serving abroad; it will now be incorporated in the new General Forces Programme.

The number of news bulletins of five minutes' or more duration, broadcast in English by the B.B.C. on short waves now totals more than twenty. The schedule, which will be operative from February 27th, with the short wavelengths on which each bulletin will be radiated, is given below. Times are BST.

0030	25.53, 30.53, 31.32, 31.55, 41.01, 41.32, 41.49, 48.78, 49.10.
0200	30.53, 31.32, 31.55, 41.01, 41.32, 41.49, 48.78, 49.10.
0300	30.53, 31.55, 41.01, 41.49, 48.78.
0345	} 41.32, 41.49, 48.78, 49.10.
0415	
0500	
0530	49.10.
0600	31.25, 31.55, 41.01, 41.49, 48.78, 49.22.
0700	19.44, 19.60, 19.66, 19.91, 25.38, 25.53, 30.53, 31.25, 31.55, 41.01, 41.32, 41.49, 42.13, 48.78, 49.10.
0800	19.60, 19.66, 19.91, 25.38, 25.53, 31.25, 31.55, 41.01, 41.49, 48.78.
0900	19.44, 24.92, 30.53, 41.32, 42.13.
1000	19.51, 19.76, 25.09, 25.42, 25.58, 30.96, 31.06, 31.17, 31.25, 31.41, 31.55, 31.61, 31.88, 41.21, 41.38, 41.49, 41.64, 41.75, 41.96, 42.46, 48.98, 49.26, 49.42, 49.92.
1100	16.92, 19.44, 24.92, 25.38, 30.53.
1200	13.97, 16.79, 19.91, 25.47, 31.12.
1400	13.97, 16.79, 19.60, 19.82, 19.91, 24.80, 25.29, 25.53, 25.68, 31.12, 41.32.
1600	13.97, 16.79, 19.60, 19.82, 24.80, 25.29, 25.53, 25.64, 25.68, 30.53, 31.12, 31.55, 31.75, 49.10, 49.59.
1700	16.79, 19.66, 25.53.
1745	19.51, 25.34, 25.58, 41.21, 41.75, 49.42.
1900	19.66, 19.82, 24.92, 25.29, 25.47, 25.53, 25.64, 25.68, 30.53, 31.25, 31.55, 31.75, 41.01, 42.46, 48.78.
2045	19.66, 25.53, 30.53, 31.25, 41.01.
2145	24.92, 25.53, 30.53, 31.32, 31.55, 41.01, 41.32, 41.49, 42.46, 48.78, 49.10.
2245	31.32, 41.32, 41.38, 41.64, 42.13, 48.43, 48.66, 48.98, 49.10, 49.26, 49.59.
2345	25.53, 30.53, 31.32, 31.55, 41.01, 41.32, 41.49, 48.78, 49.10.

In addition to the above bulletins there are those transmitted in the Home Service at 0700, 0800 (ex. Sun.), 0900 (Sun.), 1300, 1800, 2100 and 0000, which are radiated on 48.54 metres as well as on three medium wavelengths.

CANADIAN WOMEN OPERATORS
WOMEN of the R.C.A.F. are receiving an intensive six months' training to qualify for the trade of Wireless Operator (ground). They have to attain an average Morse speed of 22 w.p.m. and when qualified wear sparks on the sleeves of their uniform.

At Central Navigation School at Rivers, Manitoba, the largest of its kind in the British Empire, twenty of these girls are employed at the radio station in the control tower and their job is to maintain communication with training craft. Morse is used instead of telephony because it is faster and less susceptible to interference.

IN BRIEF

Pye Telecommunications, Ltd., is the title of a subsidiary of Pye, Ltd., formed to develop the telecommunications branch of the parent company.

The late **J. M. G. Rees**.—We announce with great regret the death, on February 6th, of J. M. G. Rees, A.M.I.E.E., a director of Oliver Pell Control. Mr. Rees, whose friendly per-

sonality made him a popular figure in the wireless industry, was largely responsible for developing the Varley radio business.

The late H. Boon.—We regret to record the death on February 3rd on H. Boon, Advertising and Publicity Manager of the Chloride Electrical Storage Company. Mr. Boon, who was well known in the wireless industry, had been with the company for fourteen years.

Reports Wanted.—The Turkish broadcasting authorities have asked for reception reports of the English transmissions from TAP, Ankara, which are radiated daily on 9.465 Mc/s (31.70 m) at 1800 and in addition on Thursdays at 2130 (BST). Reports sent care of *Wireless World* will be forwarded.

Radio Pictures.—Sir Edward Wilshaw, chairman of Cable and Wireless, stated that owing to the war there was a greatly increased demand for rapid transmission of Press photographs and of drawings and documents essential to its prosecution. At present, he said, C. and W. have ten circuits operating. They are: New York (and San Francisco), Cairo, Capetown, Bombay, Montreal, Moscow, Berne, Algiers, Stockholm, Melbourne (and Sydney).

Lord Reith's Election to the Court of Cable and Wireless and the Board of the associated companies marks his return to the "wireless fold," which he left on relinquishing the Director-Generalship of the B.B.C. in 1938.

Argentine Stations.—A decree was recently issued in Argentina prohibiting foreigners from owning or operating broadcasting stations or holding shares in the companies controlling them. It is stated the measures have been taken "until radio stations can be nationalised by the State."

One practical suggestion . . . so long as the B.B.C. devotes only two programmes to the home listener it should sharply distinguish them, keeping, say, the Forces Programme entirely for background noise and devoting the Home Programme entirely to programmes which can only be appreciated if the listener pays attention.—R. H. S. Crossman, in *New Statesman and Nation*.

Professor P. M. S. Blackett, F.R.S., who is Langworthy Professor of Physics at the University of Manchester and during the war is working for the Admiralty, has been appointed President of the Association of Scientific Workers.

I.E.E. Wireless Section.—"Some Applications of Thyratrons in Radio Engineering" is the subject of a paper to be given by A. J. Maddock, M.Sc., at a meeting to be held on March 1st. E. M. Lee, B.Sc., will open a discussion on the "Treatment and Tests for Extreme Climatic Conditions" on March 21st. Both meetings will commence at 5.30 p.m. and will be held at the Institution of Electrical Engineers, Savoy Place, Victoria Embankment, W.C.2.

Cambridge Wireless Group.—The Council of the Institution of Electrical Engineers has approved a provisional Committee to form a Wireless Group in Cambridge and District. The Chairman is C. R. Stoner, B.Sc.; Vice-chairman, B. J. Edwards, and Hon. Secretary, D. I. Lawson, M.Sc.

HOME SAFELY— THANKS TO RADIO



THE far reaching achievements of the electronics industry are being made available to the Armed Forces in ever increasing quantities.

Crowe is proud of its proven ability to produce precisely made electronic control mechanisms in large numbers.

★ Exclusively Represented by **Frank Heaver Ltd.**, Kingsley Road, Bideford, N. Devon.



CRONAME RADIO COMPONENTS

CROWE NAME PLATE AND MANUFACTURING CO. CHICAGO, ILL. U.S.A.

OF OUR ABILITIES AND FACILITIES WE GIVE GLADLY



PARAMOUNT above all else is the necessity of meeting urgent and immediate demands for the protection of cherished liberty.

Astatic's engineering and manufacturing facilities are therefore first at the disposal of Allied Governments.

Astatic will be ready to serve you again with high quality piezo-electric devices when the "All Clear" of Victory sounds.

Register your name with our Representative for your future benefit.



THE ASTATIC CORPORATION YOUNGSTOWN, OHIO, U.S.A. TORONTO, CANADA.

Exclusively Represented by **Frank Heaver Ltd.**, Kingsley Road, Bideford, N. Devon

World of Wireless—

Knighthood.—Oliver Simmonds, M.P., head of the Simmonds Group of Companies (which includes Simmonds Aerocessories, Ltd.), received a Knighthood in the recent New Year Honours List.

Competitions for Authors.—The Australian Broadcasting Commission has announced a writers' competition, with prizes totalling £1,000. There are six groups—novels, plays, documentary

features, short stories and poems. Further particulars and entry form can be obtained from the Australian Broadcasting Commission, Australia House, Strand, W.C.2.

F. E. Henderson, author of "Introduction to Valves," will lecture on the design and application of thermionic valve rectifiers at a meeting of the Institution of Electronics at 3 p.m. on March 18th at the Royal Society of Arts, John Adam Street, Adelphi,

London, W.C.2. Application for tickets should be made to Alexander H. Hayes, 64, Winifred Road, Coulsdon, Surrey

Institute of Physics.—A meeting of the Electronics Group will be held at 5.30 p.m. on March 2nd in the Reid-Knox Hall of the British Institute of Radiology, 32, Welbeck Street, London, W.1, when Dr. F. C. Toy, of the Shirley Institute, Manchester, will lecture on the electron microscope.

NEWS IN ENGLISH FROM ABROAD

Country : Station	Mc/s	Metres	Daily Bulletins (BST)	Country : Station	Mc/s	Metres	Daily Bulletins (BST)
Algeria				India			
Algiers	8.965	33.46	1600, 1700, 1800, 1900, 2100, 2200	VUD3 (Delhi) ..	7.290	41.15	0800, 1300, 1550
	12.110	24.77	1700, 1800, 1900, 2100	VUD4	9.590	31.28	0800, 1300, 1550
				VUD3	15.290	19.62	0800, 1300
America				Iran			
WRUW (Boston) ..	6.040	49.67	0800	EQB (Teheran) ..	6.155	48.74	2225
WLWK (Cincinnati)	6.080	49.34	0600, 0700, 0800, 0900,				
WKTS (New York) ..	6.120	49.03	0900	Mozambique			
WOOW (New York)	6.120	49.01	0100, 0200, 0300, 0400, 0500, 0600	CR7BE (Lourenco Marques)	9.830	30.52	2050
WBOS (Boston) ..	6.140	48.86	0900, 1000				
WCBX (Brentwood)	6.170	48.62	0500	Newfoundland			
WGEO (Schenectady)	6.190	48.47	0615, 0810	VONH (St. John's) ..	5.970	50.25	2315
WKTM (New York)	6.370	47.10	0000, 0100, 0200, 0300, 0400, 0500, 0800, 0900, 2300	Palestine			
WLWO (Cincinnati)	7.575	39.61	0600, 0700	Jerusalem	11.750	25.53	1615
WKRD (New York)	7.820	38.36	0000, 0100, 0200, 0300, 0400, 0500, 0600, 0700, 0800, 0900†	Portugal			
WGEO (Schenectady)	9.530	31.48	1000, 2100	CSW6 (Lisbon) ..	11.040	27.17	2000
WCDA (New York) ..	9.590	31.28	1200	Spain			
WCRC (New York) ..	9.590	31.28	1100	EAQ (Aranjuez) ..	9.860	30.43	2050†
WKRD (New York)	9.897	30.31	1000, 1100	Sweden			
WLWO (Cincinnati)	11.710	25.62	1200, 2000, 2100, 2200	SBU (Motala) ..	9.535	31.46	2220†
WRUW (Boston) ..	11.730	25.57	1300, 1400	SBP	11.705	25.63	1700
WCRC (Brentwood)	11.830	25.36	1530, 1630, 2045	Switzerland			
WGEO (Schenectady)	11.847	25.32	1300, 1400, 1500, 1600, 1700	HER3 (Schwarzenburg)	6.345	47.28	2150
WBOS (Boston) ..	11.870	25.27	1100	HER4	9.535	31.46	2150
WRUS (Boston) ..	15.130	19.83	1300, 1400, 1500, 1600, 1700, 1800	Syria			
WBOS (Boston) ..	15.210	19.72	1400	FXE (Beirut) ..	8.035	37.34	1735
WLWK (Cincinnati)	15.250	19.67	1400, 1500, 1600, 1700†, 1800, 1900, 2000, 2100, 2200	Turkey			
WCBX (Brentwood)	15.270	19.65	1530, 1630, 2045	TAP (Ankara) ..	9.465	31.70	1800
WGEO (Schenectady)	15.330	19.57	1200, 1300, 1400, 1700	U.S.S.R.			
WRUW (Boston) ..	17.750	16.90	1600, 1700	Moscow	5.890	50.93	2300
WLWO (Cincinnati)	17.800	16.85	1400, 1500, 1600, 1700, 1800		6.980	42.98	1240, 1700, 2300
WCDA (New York) ..	17.830	16.83	1530, 1630		7.300	41.10	1700, 1800, 2000, 2100, 2200, 2300, 2347
					7.332	40.92	2000, 2100, 2200, 2300
					9.545	31.43	1240, 1515
Australia					10.445	28.72	1240
VLL4 (Sydney) ..	7.240	41.45	1515		11.830	25.36	1600
VLG (Melbourne) ..	9.580	31.32	1515		11.940	25.13	0100, 2347
					15.230	19.70	1240, 1515
					15.750	19.05	1240, 1320
Belgian Congo				Vatican City			
Leopoldville ..	15.520	19.33	1200	HVJ	5.970	50.25	2015
Brazil							
PRL8 (Rio de Janeiro)	11.715	25.61	2030†	Algers	1,176	255	0100, 1400, 1800, 1900, 2000, 2200
China				Athlone	565	531	1340†, 1845, 2210
XGOY (Chungking)	9.635	31.14	1500, 1700, 2130	Tunis	868	345.6	0000, 0100, 1900, 2000, 2100, 2200, 2300
Ecuador							
HCJB (Quito) ..	12.455	24.09	0000, 2030				
Egypt							
Cairo	7.510	39.94	1845, 2100				
French Equatorial Africa							
FZI (Brazzaville) *..	11.970	25.06	1945, 2145				

It should be noted that the times are BST—one hour ahead of GMT.

†Sundays excepted.

Wireless World Brains Trust

What is Synthetic Sound ?

QUESTION No. 18. What is "synthetic sound"? This expression has cropped up several times lately in "Wireless World"; it seems to be applied exclusively to sound produced by methods like those devised by Rudolf Pfneniger, who painted by hand the desired wave-forms, afterwards photographing them on to a sound-track for conversion into sound.

But is it not a fact that all instrumental music might equally well be described as "synthetic"? In this respect there is only a difference in degree, and not in principle, between a penny whistle, a violin, an electronic organ and a hand-painted sound-track. The expression seems redundant and even undesirable, as it emphasises a distinction that does not in fact exist.

H. W. PAGE

This question deals with the terminology of a technique akin to that of wireless, and so with a matter that is an Editorial responsibility of "Wireless World." We propose, therefore, to depart from the usual rule of the Brains Trust, and to offer an Editorial reply to the question.

SYNTHETIC sound is sound artificially produced by combining the various component wave-forms necessary to give the desired result. The expression should be reserved exclusively to describe sound produced by methods primarily devised and designed to provide the means for synthesis.

A violin is not designed for synthesising sound, but for producing characteristic violin music. For example, it cannot produce a pure tone without harmonics.

Good examples of synthetic sound generators are Pfneniger's painted sound tracks already quoted, and the mechanical method of synthesis mentioned by C. C. Buckle in our January issue. Another example is the air-raid siren—if, as can reasonably be assumed, the designer did in fact set out deliberately to produce by mechanical means a sound having those characteristics judged to be most suitable for the purpose in view. It is debatable whether electronic musical instruments, in their present form, can properly be called "synthetic." There

seems to be a tendency in the later electronic organs to aim at producing characteristic organ music rather than providing the executant with means for synthesising sound.

Of course, if we agree that the only "natural" music is that produced by the human vocal apparatus then we may describe all instrumental music as *artificial*. But to call it *synthetic* would be a misuse of a word to which a precise meaning should be assigned. All instrumental music is not synthetic, in the sense of being consciously and deliberately synthesised or artificially built up from its elemental component parts.

To avoid confusion we propose to use the expression "synthetic sound" in the restricted sense generally, and we believe rightly, assigned to it. But here we do not claim the traditional right of the "question master" to the last word.

R.S.G.B. PRESIDENT



E. L. GARDINER (G6GR), was installed as President of the Radio Society of Great Britain at the first meeting of the Society this year. He is well known for his work on quartz-crystal filters, on which he contributed a series of articles to *Wireless World* a few years ago.



THE "FLUXITE QUINS" AT WORK

"Buck up with that FLUXITE," bawled EH,
"We can't stick around here all day,
We've got bags to do,
So come down, please do"
(And Ol did, without further delay).

See that FLUXITE is always by you — in the house — garage — workshop — wherever speedy soldering is needed. Used for over 30 years in Government works and by leading engineers and manufacturers. Of all Iron-mongers—in tins, 8d., 1/4 & 2/8.

Ask to see the FLUXITE SMALL-SPACE SOLDERING SET—compact but substantial—complete with full instructions, 7/6.

TO CYCLISTS! Your wheels will NOT keep round and true unless the spokes are tied with fine wire at the crossings AND SOLDERED. This makes a much stronger wheel. It's simple—with FLUXITE—but IMPORTANT.

The FLUXITE GUN puts FLUXITE where you want it by a simple pressure. Price 1/6, or filled, 2/6.



ALL MECHANICS WILL HAVE

FLUXITE

IT SIMPLIFIES ALL SOLDERING

Write for Book on the ART OF "SOFT" SOLDERING and for Leaflets on CASE-HARDENING STEEL and TEMPERING TOOLS with FLUXITE. Price 1d. each.

FLUXITE LTD.

(Dept. W.W.), Bermondsey Street, S.E.1

CONTRAST EXPANSION CIRCUIT

*Applying the
Principle of the
Cathode Follower*

By M. O. FELIX

RECENTLY many readers have written either for or against contrast expansion. The general opinion appears to be that while it is desirable it must be controlled accurately at both receiving and transmitting or recording ends. The object of this article is to give the circuits which may be used for this.

During the last few years there have been two types of circuit in use. The first includes all circuits using lamps, either in simple or bridge circuits. Although cheap and easy to incorporate, these have the obvious disadvantages that the expansion curve is difficult to control, and that there is considerable power wastage.

The second type consists of a variable-mu valve, the gain of which is varied by the DC output from a rectifier. A typical circuit

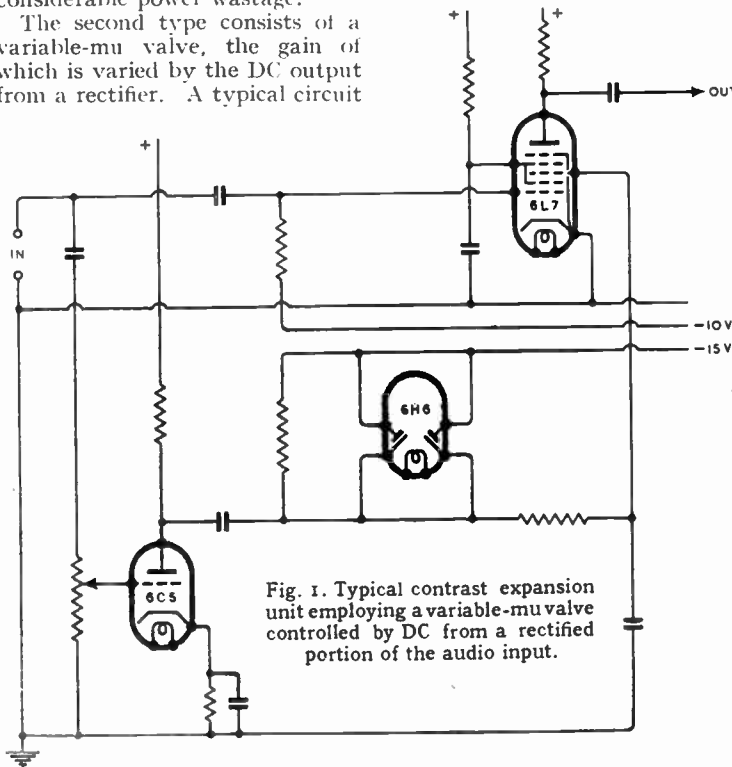

Fig. 1. Typical contrast expansion unit employing a variable-mu valve controlled by DC from a rectified portion of the audio input.

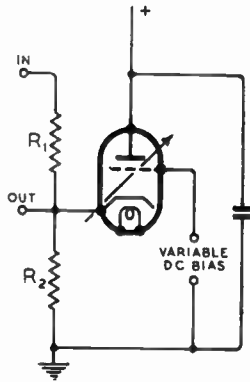

Fig. 2. Simplified circuit of a cathode follower type of contrast expansion unit.

using a 6L7 is shown in Fig. 1. The disadvantages of the circuit are:—

(1) For negligible distortion the input must be limited to 100 mV.

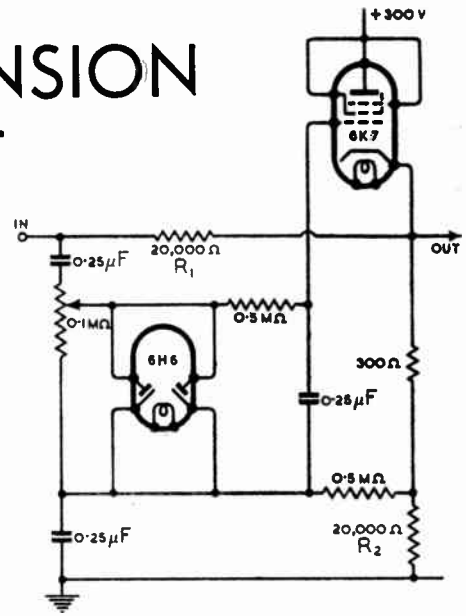

Fig. 3. Complete circuit with suggested values.

(2) The prevention of hum pick up is doubly difficult due to the very small amplification of small inputs.

(3) Receiver design is complicated since the detector output must be at least 2 volts on highly modulated signals.

(4) A separate amplifier is required before the rectifier.

(5) Several values of fixed bias are required which must be obtained either from a separate rectifier or from a heavy current potentiometer.

A new circuit using a type of cathode follower has been devised, and a simplified circuit is shown in Fig. 2. Now the output impedance of the cathode follower Z is $1/g_m$ where g_m is the mutual conductance of the valve. Assuming $Z \ll R_2$ and $Z \ll R_1$ we can write $V_{out} = V_{in} \frac{Z}{R_1}$.

The output is thus inversely proportional to the slope of the valve. Using a variable-mu pentode strapped as a triode, this can conveniently be varied by a DC bias on the control grid.

The complete circuit is shown in Fig. 3. Using a 6K7 a change of only 10 volts in grid bias varies the slope from about 2 to 0.2 mA/volt. The output thus varies from 1 to 1/5 of the input, i.e., a change of 18 db—more than will ever be required.

Other advantages are:—

(1) It will handle inputs of 20 volts or more, with no distortion, thus simplifying any precautions against hum.

(2) Using a 6K7 strapped as a triode, no separate amplifier is required before the rectifier.

(3) The output impedance is low, particularly on small inputs, so that the output may be taken via a screened lead for some distance if required.

(4) The expander can be cut out of circuit completely by biasing the valve off in any way, for instance, by inserting a large cathode bias resistor. The potentiometer ratio will then be $\frac{R_2}{R_1 + R_2}$.

It has been suggested that until controlled compression is introduced at the transmitting end, better results can be obtained by having different times of charge and discharge in the rectifier

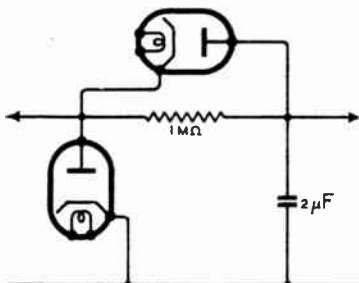

Fig. 4. Modified rectifier circuit giving charge and discharge time constants of different value.

circuit. The modification to achieve this is shown in Fig. 4, where the time constants are about

0.02 and 2 for charge and discharge respectively.

A second possibility is that the compression will require the compensation shown in Fig. 5 (this is

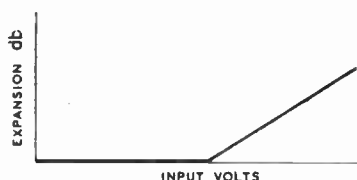

Fig. 5. "Delayed" expansion obtained by applying a fixed bias to the rectifier.

believed to correspond more nearly to that employed at present). This can be obtained by applying a DC bias to the rectifier, so that no expansion will take place until it is overcome. The value of this bias would depend, however, on the carrier level; the detector input is, therefore, taken through a separate RF amplifier, rectified and smoothed, and a proportion of the voltage fed in series with the expander diode.

Unfortunately it has not yet been possible to test this type of expander practically. If any reader tries out this circuit, I should be pleased to hear of his results.

"CO-AX" CABLES

TECHNICAL details of standard types of "Co-Ax" articulated air-spaced cables are given in a leaflet recently issued by Transradio, Ltd., 16, The Highway, Beaconsfield, Bucks. The information given is unusually full and includes figures for characteristic impedance capacity, inductance, attenuation, permissible loading, loss factor and insulation resistance.

The Improved VORTEXION 50 WATT AMPLIFIER CHASSIS

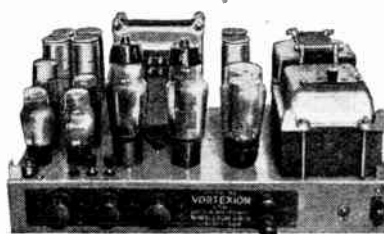

The new Vortexion 50 watt amplifier is the result of over seven years' development with valves of the 6L6 type. Every part of the circuit has been carefully developed, with the result that 50 watts is obtained after the output transformer at approximately 4% total distortion. Some idea of the efficiency of the output valves can be obtained from the fact that they draw only 60 ma. per pair no load, and 160 ma. full load anode current. Separate rectifiers are employed for anode and screen and a Westinghouse for bias.

The response curve is straight from 200 to 15,000 cycles in the standard model. The low frequency response has been purposely reduced to save damage to the speakers with which it may be used, due to excessive movement of the speech coil. Non-standard models should not be obtained unless used with special speakers loaded to three or four watts each.

A tone control is fitted, and the large eight section output transformer is available to match, 15-60-125-250 ohms. These output lines can be matched using all sections of windings, and will deliver the full response to the loud speakers with extremely low overall harmonic distortion.

PRICE (with 807 etc. type valves) £18.10.0

Plus 25% War Increase

MANY HUNDREDS ALREADY IN USE

Supplied only against Government Contracts

VORTEXION LTD.

257, The Broadway, Wimbledon, S.W.19

'Phone: LIBerty 2814

Books issued in conjunction with "Wireless World"

	Net Price	By Post
FOUNDATIONS OF WIRELESS. Fourth Edition, by M. G. Scroggle, in preparation	7/6	7/10
TELEVISION RECEIVING EQUIPMENT, by W. T. Cocking	10/6	10/10
RADIO LABORATORY HANDBOOK, by M. G. Scroggle. Second Edition	12/6	12/11
WIRELESS SERVICING MANUAL, by W. T. Cocking. Sixth Edition	7/6	7/10
HANDBOOK OF TECHNICAL INSTRUCTION FOR WIRELESS TELEGRAPHISTS, by H. M. Dowsett and L. E. Q. Walker. Seventh Edition	30/-	30/7
WIRELESS DIRECTION FINDING, by R. Keen. Third Edition	30/-	30/7
RADIO DATA CHARTS. Third Edition, Revised by J. McG. Sowerby, B.A., Grad. I.E.E.	7/6	7/10
RADIO INTERFERENCE SUPPRESSION, by G. W. Ingram	5/-	5/4
LEARNING MORSE. 335th thousand	6d.	7½d.
INTRODUCTION TO VALVES, by F. E. Henderson	5/-	5/4
VALVE REPLACEMENT MANUAL, by A. C. Farnell and A. Woffenden	6/-	6/2

Obtainable from leading booksellers or by post from

ILIFFE & SONS LTD., Dorset House, Stamford Street, London, S.E.1.

RANDOM RADIATIONS

By "DIALLIST"

A Look Ahead

TURNING the other day through the *Journal of the Institution of Electrical Engineers*, my eye was caught by a reprint of the opening address given by the Chairman of the Installations Section. He is, as is only right and proper, an enthusiast for the electrification of the home. So are most of us who are interested in the development of electricity and electrical appliances. But I wish that I had fewer misgivings from the standpoint of the wireless enthusiast about the increased use of domestic electrical appliances that is bound to come once the war is over. One diagram that accompanies the report of the address shows twenty-four different appliances intended to be plugged in to wall sockets. And, of these, nine at any rate are well-known causers of interference with radio reception. Amongst them are such things as the hair-dryer, the floor-polisher, the vacuum cleaner and the sewing machine. But, long as it is, the list makes no mention of many appliances, sure to be popular in the post-war world, which are notorious for the interference to which they give rise. I am thinking of the shaver, the egg-whisk, the cocktail shaker, the mincing machine and dozens of other things of the kind. What a pity it is that we are not planning—for really I don't think we are—to insist that all household appliances sold shall be of the non-radiating kind. We shall probably never have again such a chance as we have now of ensuring this.

A Fine Opportunity

Think for a second what an opportunity it is. A large percentage of offending apparatus in use in '39 has now been discarded as worn out; the new appliances that will flood the markets soon after the end of the war are not yet being made. And there's another point. It seems likely that household electricity supplies throughout the country will be standardised as 230-volt, 50-cycle AC. This will mean the renewal of domestic electric appliances in large areas of the country where the supplies now differ from the future standard. It would be grand if the change-over could mean the replacement of radiating apparatus with apparatus innocuous from the radio point of view. It could be done; but will it? Vested interests are strong and

obstinate. Years ago I asked why non-radiating induction motors should not be used in vacuum cleaners. The reply of one large firm was that the induction motor could not be employed since with 50-cycle AC the required speed was not to be obtained. Well, well! Surely they've heard of such things as gears?

□ □ □

Cable Faults

AS I had hoped and rather expected, a whole heap of letters from readers on the subject of tracing breaks in multi-cored cables eventually reached me. It was some time before they did, for I was on a tour of inspection in the far chilly north of these islands. My best thanks to all who were kind enough to send me their suggestions. My original query, if you remember, was this: one pair in a cable containing a considerable number of cores is found to be "dis," both leads being broken. The length of the cable is 200 yards. It is rubber covered, but not screened. No measuring instruments but an Avometer and a wavemeter are available. What is the best method of locating the break? It is important to do so within a few inches so that as little as possible of the valuable cable may be wasted in making the necessary repair. The question aroused considerable interest, for the replies were many. One remarkable point is that no two suggested methods were exactly the same. Quite a number would have worked well if the problem had been to locate a break in one lead of a cable containing but a single pair, but did not pan out for big multi-cores. Others, again, required instruments that were not available and could not have been obtained for some little time—if at all—and it was important to have that cable in working order again as quickly as possible.

Suggestions

My original idea was to measure the capacity of the broken pair and to compare it with that of a sound pair. This could be done by using each in turn as the tuning capacity of an oscillating circuit. The wavemeter, by the way, was a very accurate one. One reader, who is an apprentice, made the interesting suggestion that an electrocope should be rigged up and charged by means of a battery, and first the broken pair and then a sound pair.

But, as so many correspondents point out, it is better, whatever capacity method is used, to rely on wire-to-earth rather than wire-to-wire measurements in a multi-core cable. Several methods of using a pair of headphones, a buzzer and a search electrode are described, and I feel that these are probably the most promising lines to work on: telephones and buzzer are practically always available at an Army station, however small.

Fellow Sufferers!

Two Post Office engineers, who describe themselves as brother sufferers, speak of the damage done by "mechanical monsters," which seem to take a fiendish delight in discovering the whereabouts of cables laid in unmade ground and then in driving over them, and so doing them what the British soldier calls a spot of no good. Yes, I've had some of that, alas! And mechanical monsters are not the only destroyers. One morning I laid a multi-core temporarily across an asphalt parade ground, carefully warning all and sundry to keep away from it. Imagine my feelings when a little later I came back to the scene to find a whole battery at marching drill and within a yard or so of my cherished cable. Seeing me, the officer in charge hastily gave an about-turn. But he was just too late. That about-turn, with the smart and soldierly stamping of hobnailed and iron-heeled boots, was made right on top of the cable. I realised then the meaning of "moments too big for words." But to return to the P.O. engineers. Their method couldn't have been employed, for it needs either a calibrated slide-wire or a pair of P.O. resistance boxes. But it's ingenious and well worth trying out when such things are available.

An Ingenious Idea

Briefly, the far ends of the faulty pair are first of all connected up to those of a good pair. The resistance of the slide-wire or the two resistance boxes in series is then connected between the near end of the broken lead (it is assumed that only one is "dis") of the faulty pair and the near end of one of the good pair. The near ends of the other two wires are joined and a pair of phones is connected between them and the slider of the slide-wire. The secondary of a screened transformer is connected across the resistance of the slide-wire, its primary being

fed by a buzzer. The slider of the slide-wire is adjusted for a minimum signal in the phones. Then the distance from the near end to the

break is $\frac{2PL}{P+Q}$, where L is the length of the cable in yards; P the resistance between the slider and the good wire; and Q the resistance between the slider and the broken wire. The principle involved is that "the impedance of a pair up to the disconnection and the loop-back from the disconnection via the far end are inversely proportional to the capacities of these paths."

□ □ □

The Wondrous CRT

THE more I use the cathode-ray tube (and that means every day) the more I marvel at the wonderful things it enables us to do already and its potentialities in the future when peace returns. In it the nimble electron can truly be said to have been harnessed for man's service and made to show its abilities as in no other apparatus that I know. We shoot a shower of electrons from a "gun," make it pass through apertures and between plates and so produce on a fluorescent screen a spot of light, which can be focused, brightened or dimmed and made to move in any direction at well-nigh incredible speeds. And with this tiny spot we can draw the pictures of television or make an electric circuit give an ocular demonstration of exactly what is going on within it. Possibly one of the greatest marvels to early workers in the field of electricity, were they brought to life again to-day, would be the fact that the movements of the electron beam can be started, stopped and reversed in direction without any appreciable time-lag. Considered as a particle of negative electricity, the electron has mass, yet it seems to be unaffected by such things as inertia and momentum. In years to come we may wonder how in the past we ever managed to design wireless apparatus without the aid of the cathode-ray oscilloscope. There should be no guess work about the wireless sets of the future, for there are few, if any, secrets hidden from the CRO. Nor will fault-finding provide such baffling problems as it was wont to do of old; the cathode-ray oscilloscope provides the trouble shooter with a magic eye indeed.

WASTE PAPER

MOBILE map units now follow our armies into battle and their printing machines are capable of turning out 5,000 maps per hour. These are printed on specially toughened, high-grade paper—one more reason why paper is urgently wanted to equip the Army for its attack on the enemy.

Forward . . .

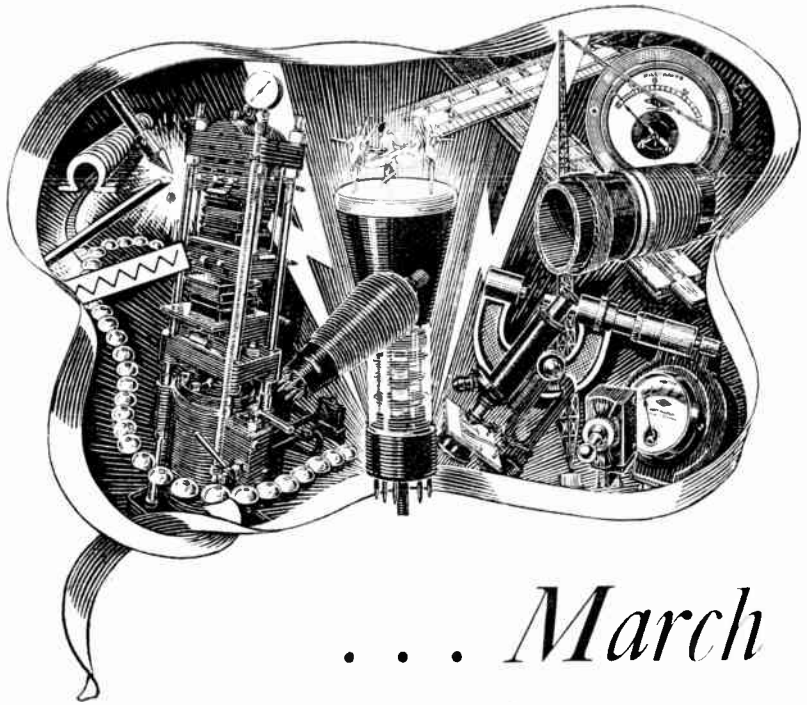

. . . March

THE science of Electronics moves apace in present time of War, but the future holds promise of great achievements. At present, we may only see "as in a glass" the fashion of things to come. In all phases and in all applications, BULGIN RADIO PRODUCTS will make their contribution; until then, we ask your kind indulgence. Please quote priority and Contract Nos.

"The Choice of Critics"

BULGIN

A. F. BULGIN & CO. LTD., BYE PASS RD., BARKING, ESSEX
Radio and Electrical Component Manufacturers.
TEL.: RIPPLEWAY 3474 (4 lines).

RECENT INVENTIONS

RADIO BEACONS

TWO unmodulated carrier waves are radiated simultaneously. One wave of frequency f_1 has a phase which varies progressively around the periphery of any circle centred on the beacon. The other wave of frequency f_2 is radiated omnidirectionally. A periodic signal of frequency $(f_1 - f_2)$ is also transmitted in order to correlate the phase of the first wave with some datum point such as the north-south line passing through the beacon.

The variable-phase frequency f_1 is produced by feeding two "crossed" pairs of vertical aerials in phase-quadrature, whilst the second frequency f_2 is radiated from a single aerial, so that its phase varies normally, i.e., progressively with distance. The "zero" or datum signal is obtained by periodically interrupting one or both of the carrier waves at times which are synchronised with the passage of the rotating phase through geographical north.

At any distant point, a beat frequency of $(f_1 - f_2)$ will be detected, its phase being determined by the orientation of the receiver relatively to the beacon. The detected beat frequency is fed through a phase-splitter to the deflecting plates of a cathode-ray tube, so as to produce a circular trace, which is momentarily brightened (or deflected) by the datum signal, thereby giving a direct visual indication of the required bearing.

Standard Telephones and Cables, Ltd., and C. W. Earp. Application date April 3rd, 1942. No. 556476.

TUNING HOLLOW RESONATORS

THE tuning of a hollow resonator, such as is used for ultra-high frequencies, is usually effected either by varying the dimensions of the resonator, say by telescoping, or by providing a suitable capacity shunt at a potential loop.

According to the invention a resonator consisting of a hollow conducting box or tube and a coaxial inner tube is tuned by a variable condenser of the standard type located at the open end of the system. The fixed vanes are connected to the outer conductor whilst the moving vanes are connected to the adjacent end of the inner tube, so that the effective capacity is in shunt across the ends of the two coaxial elements.

The moving vanes are rotated by a spindle which passes through the centre of the hollow inner tube and is fixed to a control knob mounted outside the plate closing the far end of the resonator. This is located at a potential node, so that hand-capacity effects are negligible. The arrangement is suitable for tuning a short-wave receiving set.

Kolster Brandes, Ltd., and D. N. Corfield. Application date March 20th, 1942. No. 556167.

A Selection of the More Interesting Radio Developments

VELOCITY MODULATION

RELATES to the construction and mounting of the resonant cavities or chambers used for amplifying or generating ultra-short waves by velocity-modulating an electron stream.

As shown in diagram (a), a discharge tube of the cathode-ray type is fitted with a gun G, a target electrode T, and two sets of electrodes S, Si, which define gaps through which the electron stream passes. Each of the gaps is associated with an external resonant chamber R, Ri, respectively. An annular part of each of the gap structures extends through the glass wall of the tube into the resonant chamber, the tuning of the latter being accurately adjusted by means of plungers P, Pi.

The construction of the resonators is shown more clearly in diagram (b). Each consists of two metallic halves

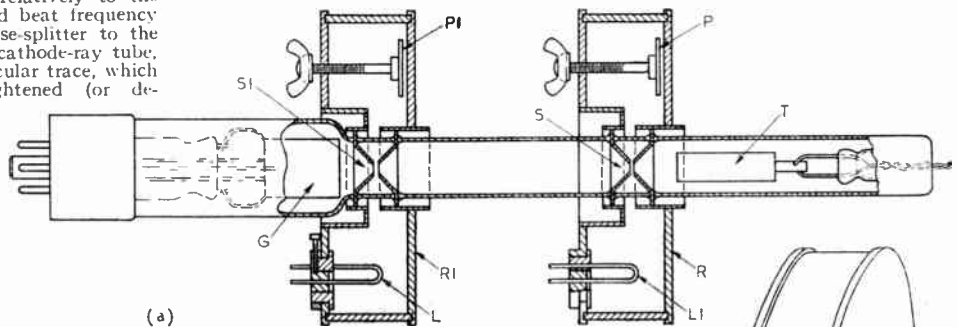

which are hinged together at one end, and closed by a hook and catch at the other, so as to fit snugly around the gap electrodes, the flexible slotted skirts F ensuring good contact.

The first resonator Ri may, for instance, be excited by means of a loop coupling Li. The electron-stream passing through the gap Si is then frequency-modulated or "bunched," and in passing through the next gap S excites the second resonator R, from which amplified oscillators are fed to a load circuit through a loop Li.

Standard Telephones and Cables, Ltd. (communicated by Western Electric Co., Inc.). Application date March 28th, 1942. No. 555162.

AUTOMATIC STEERING CONTROL

RELATES to a photoelectric device for indicating the angular movement of a body relatively to a fixed magnetic flux, such as the earth's field.

A balanced magnet carrying a small mirror is hung so as to be free to rotate in one plane in a transparent damping fluid such as paraffin, and is flanked by two bars of high permeability, which act as inductors to emphasise the effect of the earth's field on the magnet. Light from a lamp is normally reflected from the mirror on to a photo-

electric cell, which is included in the grid circuit of a gas-filled relay.

The magnetic assembly is mounted on a rotatable platform, so that the flanking bars can be set at right angles to the earth's field where the craft to be controlled is following a predetermined course. Any departure from the course will cause the magnet to swing, so as to alter the incidence of the light reflected on to the photoelectric cell, and thereby operate the gas-filled relay. This can be used either to indicate the deviation, or to operate the steering control in the direction required to bring the craft back to its course. Two such relays may be used to control the horizontal and vertical movements respectively of an aircraft. The arrangement can also be used to indicate the presence of an unknown magnetic field.

D. C. Gall. Application dates March 14th and 21st, 1942. No. 556175.

DRY-CONTACT RECTIFIERS

AN AC rectifier of the selenium type is provided with a counter-electrode made wholly or substantially of pure silver. This is stated to give

Demountable velocity modulation tube

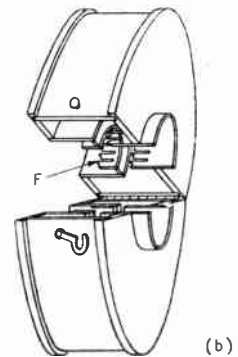

a higher rectification ratio than the metals or alloys hitherto used. The combination also results in a favourable "bottom-bend" characteristic.

The electrode may be sprayed or sputtered on the selenium or applied in the form of foil.

Westinghouse Brake and Signal Co., Ltd.; L. E. Thompson and A. Jenkins. Application date March 25th, 1942. No. 556310.

The British abstracts published here are prepared with the permission of the Controller of H.M. Stationery Office, from specifications obtainable at the Patent Office, 25, Southampton Buildings, W.C.2. price 1/- each.

*Over twenty years of
experience and research
are behind the advanced
technique of today . . .*



MULLARD
THE MASTER VALVE
A Valve for Every Purpose

DOMESTIC · COMMERCIAL · INDUSTRIAL · SCIENTIFIC · MEDICAL · EXPERIMENTAL

THE MULLARD WIRELESS SERVICE CO. LTD., CENTURY HOUSE, SHAFESBURY AVENUE, LONDON, W.C.2. (77 rev.)

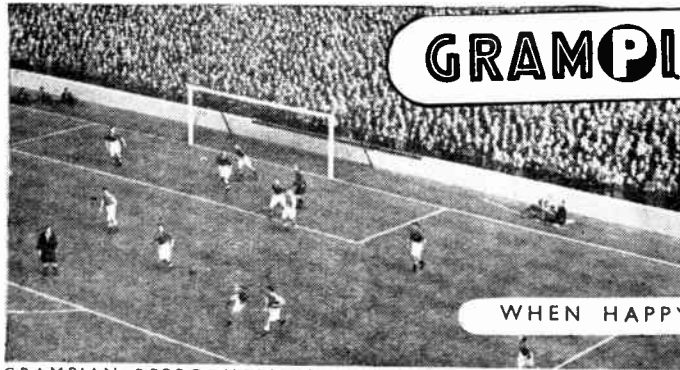

GRAMPIAN

'**SOUND
IN SOUND**'

- ★ SPEAKERS
- ★ AMPLIFIERS
- ★ MICROPHONES

WHEN HAPPY DAYS ARE HERE AGAIN

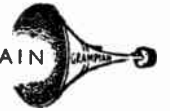

GRAMPIAN REPRODUCERS LTD. HAMPTON ROAD, HANWORTH MIDDLESEX.

Telephone: FELtham 2657-9

I am the c.g.s. unit of energy—you'll find me in every radio circuit.



E. R G

ERG is the trade mark that will identify our products of quality—small parts for big jobs.

ERG RESISTORS LTD.

1021a, FINCHLEY ROAD, LONDON, N.W.11
PHONE: SPEEDWELL 6967



Superspeed
CORED SOLDER
A.I.D. APPROVED

H. J. ENTHOVEN & SONS LTD.
230 THORNTON ROAD, WEST CROYDON, SURREY
THORnton Heath 2462

MELTON METALLURGICAL LABORATORIES LTD

Liquid Silver, Platinum and Gold
for metallising CERAMIC, MICA, QUARTZ or GLASS.
Low melting-point **SOLDER** from 70°C.
Non-corrosive Liquid **FLUX** for all electrical purposes. A.I.D. Approved.
Agents for Australia: A. S. HARRISON & CO. PTY. LTD.
85, CLARENCE STREET, SYDNEY.
IPSWICH RD., TRADING ESTATE, SLOUGH, BUCKS. Phone: Slough 20992

Varley

TRANSFORMERS and CHOKES
For **RELIABILITY**
SEND US YOUR ENQUIRIES
OLIVER PELL CONTROL LTD
CAMBRIDGE ROW, BURRAGE ROAD, WOOLWICH, LONDON SE

Remember-Walter
J.C.H. LTD

RADIO STAMPINGS • RADIO CHASSIS • RADIO PRESSINGS

FARM LANE, FULHAM, S.W.6. TELEPHONE: FULHAM 5234

BASICALLY BETTER...

Air Insulation is the basic principle of **CO-AX** LOW LOSS CABLES *Unequaled* H.F. PROPERTIES

TRANSRADIO LTD. Inc. TELEQUIPMENT CO. 16 HIGHWAY, BEAconsFIELD.

C.R.C.1

CLASSIFIED ADVERTISEMENTS. Rate 6/- for 2 lines or less and 3/- for every additional line or part thereof, average lines 5-6 words. Each paragraph charged separately. Press Day: April issue, first post Friday, March 10th, one day earlier at branch offices. Box Numbers 2 words, plus 1/- Deposit System: particulars on request. No responsibility accepted for errors.

The HIGH-FIDELITY REPRODUCTION OF MUSIC.

A Discussion - Meeting of The British Institution of Radio Engineers is to be held on 10th March.

Dr. Malcolm Sargent will be the principal speaker and the discussion will be opened by

Dr. Norman Partridge

Admission is by ticket only and application should be made to The Secretary at the offices of the Institution, 9, Bedford Square, London, W.C.1.

N. Partridge

Transformer Manufacturers,
76-78, PETTY FRANCE, LONDON,
S.W.1. Telephone: ABBey 2244.

ARMSTRONG SERVICE

Man proposes but war disposes! That is why there has been some delay in our Service Department, which we greatly regret.

Happily, however, we have caught up with arrears and can now service receivers and return most of them in seven days.

Whilst this position lasts we can also undertake the repair and overhaul of receivers other than our own make including American types.

All enquiries should be addressed to

ARMSTRONG (Radio Service Dept.)
WALTERS ROAD, HOLLOWAY, LONDON, N.7
Phone: NORth 3213

NEW RECEIVERS AND AMPLIFIERS

30-WATT ac amplifiers, precision built instruments, input and output channels to requirements; early deliveries.—Below.
150-WATT racks, comprising 5 amplifiers as above intercoupled, fitted for remote control for industrial installations; send for full details and illustrations; complete equipment, including speakers and microphones, etc., available.—Below.

18-WATT ac/dc amplifiers, mixing input channels, bass and treble controls, input and output transformers; 18gs.—Below.
DANCE and stage transportable equipment, comprising 18-watt amplifier as above, m/c mike, adj. stand, 2 speakers, cables; 36gs.—Broadcast & Acoustic Equipment Co., Ltd., Broadcast House, Tombland, Norwich. 26970.

AMPLIFIERS and tuning units, ac or ac/dc, any power ratings; special designs for essential work; sub-contracts accepted.—Norton, 49, Clifford Ave., London, S.W.14.

£24 World quality amplifier with tone control stage, 8 watts push-pull trade output, price includes super quality triple cone, 12in permanent magnet speaker with large matched output transformer and all valves; as above but with 15-watt tetrode output, £25. ideal for realistic reproduction for public address, limited number available.—Bakers Selhurst Radio, 75, Sussex Rd., S. Croydon. Tel. Croydon 4226 for demonstration. [2474

NEW radio chassis, contain 8 Octal valve holders, 27 mica condensers, 30 resistances, 4 tubular condensers, volume control, 7 screened coils, trimmers, 5nfd 500v electrolytic, £2; new Philips 11v television chassis, includes scanning coils and mains pack, no valves, £12/10; new Shaftesbury 10watt portable amplifier, microphone, stand, speaker plugs, cables, etc., complete in rexine case, 30gs., suit audiences of 600; Rothermel crystal microphones on telephone type stand, £4/10; Shaftesbury crystal microphones on telescopic floor stand, £6/15; Rothermel senior crystal gram pick-ups, £3/17/6; 2-volt 45-ampere glass accumulators, 10/6; American GT valves; orders over £3 carriage paid.—H.P. Radio Services, Ltd., 55, County Rd., Liverpool, 4. Tel. Aintree 1445. Est. 1935.

RECEIVERS and **SECOND-HAND** FOR sale, 230 volt ac National H.R.O. Senior, with 9 coils—Apply Box 3048. [2426
H.M.V. 660 Auto AC/16G 5 wave-bands super model, perfect; offers.—Box 3057. [2477
COMPLETE vision chassis, ex-H.M.V. 900, as new; £15.—BM/ZIDDF, London, W.C.1.
£80—As new, commun. rec., Eddystone 358, coils A to F.—Barber, Laindon 3291.

DEAF, aids, Ardenite, Radioaid, Amplivox: offers.—44, St. Andrews Rd., St. Ann's, Lancs. [2457

30-WATT amplifier, new, and 2 G.12 speakers; 45gs.—Tel. Wimbledon 5703 after 5 p.m. [2493

TANNAY amp ac/dc 6w, new valves, mike, e.p.k.—£17, offers.—Russell, Castle St., Buckingham. [2472

PARMEKO super recording amplifier, fully metered, perfect; £75.—Benson, Bush Barn, Robertsbridge. [2448

CHALLENGER 18-valve super-twin 6-wave, 4½-2,000, assembled in black metal cabinet, G12 p.m. speaker; offers; Lancs district.—Box 3062. [2499

R.M.E. 69 communication receiver, crystal filter, signal meter, 9 to 550 metres, matched speaker; offers.—41, Lichfield Rd., Walsall. [2476

THREE radiograms, McMichael, Ekco, Marconi, also American Freud Eissman mid get set, perfect, take £20 for Marconigram.—Ring Bays, 0363. [2461

HARTLEY-TURNER type 111.F. tuner and 7-watt push-pull amplifier, including h.t. speaker and valves except PX4s; best offer; Regentone W.2A mains unit, £2 10.—Box 3054. [2449

AMERICAN 16-valve de luxe Auto Radiogram, period style cabinet, remote control, band width variable for super fidelity band spread, tuning seven wave-bands, 15 meters upwards; £200.—Box 3065. [2510

RADIOGRAM, 20 valve, 6 wave-band, £25; bookcase radio, new, £40; communication receivers, Music While you Work outfits, etc., fitted with 18in cinema speakers; amplifiers ac and ac/dc; autochangers and communication receivers wanted urgently, good prices paid.—Mai, 9407, 65, Carlton Mansions, Randolph Ave., London, W.9. [2481

WANTED, midget or small ac superhet, in good condition.—Box 3060. [2489

WANTED, wireless receivers, any quantity, going or otherwise!!—Cathodyne Radio Services, 134a, South Faling Rd., W.5. Tel. Fal. 1368. [2425

Advertisers and buyers are reminded that under Defence Regulations 1939, Statutory Rules and Orders 1940, Number 1689, a permit (T 99 G) must be obtained before sale or purchase of certain electrical and wireless apparatus, particularly such valves and apparatus as are applicable to wireless transmission.

THE RADIO INSTRUMENT CO.

MAINS TRANSFORMERS (available from production) Type A, 350/0/350 v., 100 m.a., 4 v. 2 a., and 4 v. 4 a., CT, £7/-.
Type B, 350/0/350 v., 100 m.a., 5 v. 2 a., and 6.3 v. 4 a., CT, £7/-.
Type S, 350/0/350 v., 80 m.a., 4 v. 2 a., and 4 v. 2 a., and 4 v. 4 a., CT, 26/-.
SPECIAL NOTICE

We regret that, due to the restrictions on supplies of No. 33 Laminations, we are unable (for the present) to supply the larger types of transformers from our range, except to orders bearing a

PRIORITY CONTRACT NUMBER.
The following types are therefore withdrawn from general distribution: W, X, Y, Z, AZ and OP12 output transformer.

WOUND BOBBINS.
Mains trans. bobbins, specification as types A and B. Size of aperture, 1½in. square, 1½in. long through. Interleaved and impregnated, 18/6 each.

SPEAKER TRANSFORMER BOBBINS.
The popular replacement standard, tapped either triode or pentode, 2/6 each, £7/- per doz.

COMPLETE SPEAKER TRANSFORMERS.
Replacements for Bola, Celestion, etc., usual fitting. Tapped Triode/Pentode, 6/- each, 65/- doz.

WAVECHANGE SWITCHES.
Six-bank four-way Yaxley types, 7/6.
Two-bank 5-way, makes useful meter switch, 3/11.
Three-bank 3-way, wavechange, 5/6.

BLACK POINTER KNOBS.
For meters or wavechange, ½in. bore, 9d. each, 7/6 doz.

SCREENED MIKE CABLE.
Single conductor, 7/6 doz., twin 12/6 doz. yards.

MOVING COIL METERS.
Flush bakelite case, 100 D.C. res. 1½in. scale marked in .2 m.a. to 1 m.a. (limited number only), 60/-.

TRADERS, SERVICE MEN: A new yellow list is fresh from print; we are again commencing the Monthly Bulletin to subscribers on our mailing list (one shilling per year). Application should be made on business heading.

FOR ALL YOUR SERVICE SPARES—WRITE OR PHONF

THE RADIO INSTRUMENT CO.
294, BROADWAY, BEXLEYHEATH, KENT.
Phone: Bexleyheath 3021.

L.R.S. STUART PUMPS

As supplied to Govt. Depts. & County Councils



Prompt Delivery

These Centrifugal Pumps are ideal for Machine Tool Cooling and all pumping purposes—hot or cold water. Supplied complete with foot-valve, strainer and hose union. Suitable rubber hose available from stock.

No. 10, 100 gals. per hour. Carr. 2/- extra. 25 2 6
No. 11, 280 gals. per hour. Carr. 2/- extra. 26 6 0
No. 12, 660 gals. per hour. Carr. 3/- extra. 27 12 0

Please send 2d. stamp for specification. State purpose for which pump is required.

AVOMINOR AC/DC and DC METERS
Prompt delivery. Priority Orders only.

LONDON RADIO SUPPLY CO.
Estab. 1925
Ardingly Road, Balcombe, Sussex



We're doing our best, too! And although we don't fear physical violence, we do fear your grouches when we disappoint you on Transformer deliveries. But in these days of heavy priority work orders pile up and supplies get short and, regretfully, we must say more often than we should like, "Sorry, no transformers." So please don't shoot us—we're doing our best.

**GARDNERS
RADIO LIMITED**
*Manufacturers of
Very Good Transformers*
SOMERFORD • CHRISTCHURCH • HANTS



**FOR THE
RADIO SERVICE
MAN, DEALER
AND OWNER**

The man who enrolls for an I.C.S. Radio Course learns radio thoroughly, completely, practically. When he earns his diploma, he will KNOW radio. We are not content merely to teach the principles of radio, we want to show our students how to apply that training in practical, every-day, radio service work. We train them to be successful!

INTERNATIONAL CORRESPONDENCE SCHOOL

Dept. 38, International Buildings,
Kingway, London, W.C.2

Please explain fully about your Instruction in the subject marked X.

**Complete Radio Engineering
Radio Service Engineering
Elementary Radio Television**

And the following Radio examinations:
**British Institution of Radio Engineers
P.M.G. Certificate for Wireless Operators
Provisional Certificate in Radio Telephony and
Telegraphy for Aircraft
City and Guilds Telecommunications
Wireless Operator & Wireless Mechanic, R.A.F.**

Name..... Age.....
Address.....

AMERICAN Sky Chief portable receiver. Bolt, 62, Hamilton Rd., Alford, Lincs

WE offer cash for good modern communication and all-wave receivers.—A.C.S. Radio, 44, Widmore Rd., Bromley. [1541]

LONDON CENTRAL RADIO STORES will pay good prices for receivers, radio-grams, amplifiers, dynamos, converters, test equipment, electric gramophone motors, and all radio and electrical accessories.—London Central Radio Stores, 23, Lisle St., London, W.C.2. Gerrard 2969. [9836]

NEW LOUSPEAKERS

BBROADCAST 12in p.m. loud speakers, precision built instruments to lab. standards and micrometer accuracy. Ticonall magnets, demountable diaphragm and magnet assemblies, perfect and permanent alignment, extended frequency range, uniform response, superior acoustical characteristics, maximum sensitivity, highest efficiency.—Broadcast & Acoustic Equipment Co., Ltd., Tombland, Norwich. 26970. [2025]

£5 Auditorium permanent magnet speaker with triple cone, manufactured by Bakers Selhurst Radio, the pioneer manufacturers of moving coil speakers since 1925, wide frequency range, even response, ideal for quality reproduction, fitted with 1½in speech coil and magnet having exceptionally high flux density in the air gap, suitable for public address equipment when quality reproduction is first consideration; send 2/6d. stamp for leaflet giving details of features and constructional details of loud speaker frequency range; also constructional details of an infinite baffle cabinet; every music lover interested in realistic reproduction should write for leaflet.

£8/15 only.—Brand new Super Power Cinema permanent magnet speaker with 18in triple cone; will handle 20 watts U.D.O., ideal for quality public address equipment when power handling capacity plus realistic reproduction is required.—Bakers Selhurst Radio, 75, Sussex Rd., South Croydon, Tel. Croydon 4226 for demonstration. [2475]

LOUSPEAKERS SECONDHAND

2 B.T.H. R.K. speakers, good condition: £5 each.—Box 3059. [2485]

HARTLEY-TURNER, with infinite baffle cabinet, rectifier, etc., as new; £7.—42, Grimshaw Rd., Peterborough. [2496]

HARTLEY TURNER Duode, 2,440 ohms. P.P.L.L. output trans. £6; Goodman 8in P.M., Ign.—232, East Park Rd., Leicester.

WE. 555 W. unit and folded Exponential horn, £27/10; Voigt twin cone unit, brand new condition.—Offers to R. Neall, 91 Broad St., Daventry. [2413]

BAKER, 6-ohm, 600, with mains transformer, metal rectifier and condensers, recently fitted new triple cone.—The Lodge, Barys Court, Leigh, Reigate. [2487]

Wanted

HARTLEY Turner speaker; price and particulars, please.—Box 3055. [2469]

G.12 P.M., with 150hm speech coil; must be perfect; state price, etc.—Sculley, 52, Ridgeway, Hayes, Kent. [2504]

WANTED, Voigt domestic corner horn with base chamber; circuit of Hamrad 140 comm. rec.—Noakes, Cobden St., Leicester.

DYNAMOS, MOTORS, ETC.

VALVE (BTH), heavy duty rectifier, input 200, 240 volts, output 40-90, volts 30 amps; £35.—Neall, 91, Warwick St., Daventry.

ALL types of rotary converters, electric motors, battery chargers, petrol-electric generator sets, etc., in stock, new and second-hand; supplied against priority orders only.

WARD, 37, White Post Lane, Hackney Wick, E.9. Tel. Amherst 1393. [1988]

ROTARY converter by Electro Dynamic Construction Co., 230 volts 521 amps ac to 230 volts dc, in excellent order; £15 or near offer.—Baylis, 67a, Clarendon Rd., W.11. [2422]

ML rotary transformer, dc to dc, input 50 volts, output 500 volts 150 ma, as new. £9; Epoch M.C. microphone and trans., £6; Novatone model H, £5; numerous components; send stamped addressed envelope for list.—Castagnoli, 71, Culver St., Colchester.

LT. dynamos for charging. Lucas-Rotax, 6-12v 8 amps dc, 3rd brush, weight 11lb size 8in x 4½in, nnused ex W.D., cost £10, to clear 17/6 each; ht and lt G.E.C. double current 6v and 600v, 17lb ditto, 27/6; all carr. paid England and Wales.—Electradix, 214, Queenstown Rd., Battersea, S.W.8. [1748]

ALTERNATOR by Crompton Parkinson, 3kw, 110 volts, 27 amps, 60 cycles (or 100 volts 50 cycles), £25; Crypto rotary converter, 230v d.c. to 230v a.c., 750 watts, £17; 200v a.c. to 110v a.c. 500 watts, £15; 250v d.c. to 230v a.c. 900 watts, £25; 250v d.c. to 110v a.c. 1,500 watts, £27; 110v d.e. to 75v 2,500 watts, £30; also dynamos and lighting sets up to 5kw.—Harris, Strouds, Brixfield.

HILL & CHURCHILL
BOOKSELLERS
SWANAGE DORSET

ENGLISH & AMERICAN
BOOKS IN STOCK ON

**RADIO AND
TELECOMMUNICATION**

CATALOGUE ON APPLICATION

**LAMINATIONS & SCREENS
RADIOMETAL · PERMALLOY
SILICON ALLOYS**

Electrical Sound & Television Patents Ltd.
12 PEMBROKE STREET, N.1

COVENTRY RADIO
COMPONENT SPECIALISTS SINCE 1925

Latest List of Coils, Condensers, Transformers, Resistors, Switches, Speakers, Trimmers, Chokes, Rectifiers, Volume Controls, Instrument Wires, Flex, etc.

Sent on receipt of 1d. stamped envelope

THE COVENTRY CO.,
191, DUNSTABLE ROAD, LUTON

VOIGT

For high quality loud speakers when the good times come again.

The Courts, Silverdale, London S.E.26. Phone: SYD 6666.

SALFORD Selenium
PHOTO-ELECTRIC CELLS

**ENLIGHTENMENT
ON LIGHT**

A Range of Standard sizes available — mounted or unmounted. Special sizes to order.

Please address enquiries to—
SALFORD ELECTRICAL INSTRUMENTS LTD.
PERI WORKS, SALFORD, J.

Telephone: BUSHBY (441 to 444) Telegrams: PERELEC, MANCHESTER
PROPRIETORS: THE GENERAL ELECTRIC CO. LTD., OF ENGLAND

VALVES

This is part of our current stock of valves and if all their equivalents were mentioned it would be found that we can supply either the exact valve or a suitable replacement for almost any type. Wherever possible please order C.O.D. Stamp with enquiries, please.

PRICES STRICTLY B.O.T. RETAIL

BATTERY.—210HL, LD210, 5/10; LP2, P220, PM2A, 7/4; HD24, TDD2A, 9/2; 210SFT, 210VPT, 210SG, 220HPT, 220/OT, HP210, KT2, KT2A, PM12M, PM22A, SP2, S215VM, VP2, VP2B, X22 W21, Z21, Z22, 11/-; 230XP, 12/2; X24, 12/10.
A/D TYPES.—2DA, 6/9; 904V, AC2HL, MH4, MH14, 9/2; AZ1, AZ31, DW2, DW4-500, 1W4-350, NU14, 11/-; AC044, MH41, PX4, TDD4, 11/7; AC1VP1, AC1VP2, AC1Pen, AC2Pen, AC5Pen, MVSPen, MVSPenB, PenA4, PenVA, SP4, VP4, VP4B, VPT1, 12/10; AC7H1, AC7PT, PC4, MX40, TH4, TX41, VHT4, 4MXP2, 14/-; PenB4, 14/8; PenDD, 15/3; MP/Pen, 16/6; PW4-500, 18/3; PX26, PP3 400, 24/4; Pen428, 30/5.
UNIVERSAL.—2113A, 9/2; CY1, U31, UR1C, UR3C, U4020, 11/-; 11D3, TDD13, 11/7; 8D2, 9D2, 138FA, CL4, CL33, Pen36C, SP13, SP1320, VP13A, VP13C, 12/10; PenDD4020, 15/3.
MAZDA.—H123, 5/10; U15, U16, U17, VP23, 11/-; H14HD, H143HD, 11/7; Pen45, SP41, TP23, VP41, 12/10; TH41, TH233, 14/-; QP25, PenDD4020, 15/3.
E. TYPES.—EM4, 11/-; EBC3, EBC3C, 11/7; FC1, CL33, PFP, EL3, EL33, 12/10; ECH2, ECH3, ECH35, EFP, EFP, EK2, EL2, 14/-; EB11, EB11A, 15/3; EL5, 16/6; EL33, 18/3.
AMERICAN.—024, 1A5, 1A6, 1A7, 1B5, 1C5, 1H5, 1H6, 2A6, 2A7, 5C4, 5Y3, 5Z4, 6A3, 6A4, 6A6, 6AG6 6A7 conversion, 6C6, 6D6, 6C8, 6E6, 6F6, 6F6, 6P8, 6H6, 6G5, 6J7, 6K6, 6K7, 6K8, 6L6, 6L7, 6P5, 6Q7, 68C7, 68F7, 6V6, 6X5, 6Z5, 10, 12A5, 12Q7, 12A7, 12S7, 12Z5, 15, 19, 24, 25, 25A7, 20D8, 25Y5 conversion, 25Z5 conversion, 25Z6, 32, 33, 34, 35, 37, 38, 48, 48, 49, 50, 53, 57, 71A, 75, 76, 78, 79, 80, 81, 85, 89, 186R8 (Ballast), K55B and C (Ballast).

VALVES & ADAPTORS

In the few cases where we cannot supply the exact valve or equivalent we can get your set going with a valve and an adaptor, the additional cost being 4/-

SPARES

KIT OF 12 TOOLS in American cloth folder, very handy, 30/-.
LINE COB.—3 amp, 3 core 60 ohms, per ft., extremely good quality, 6/9 per yd. **CELLULOSE CEMENT** for speaker valve and most other repairs, 5/- large tin. "SERVIS L" more than a switch cleaner, 5/- tin. **MAINS TRANSFORMERS**, 350-0-35, 4-volt heaters, 29/3; **VOLUME CONTROLS**, with switch, 7/6; **VALVE EQUIVALENT CHARTS**, 1/7, post free.

J. BULL & SONS

(Dept. W.W.)

246, HIGH ST., HARLES DEN, N.W.10.

R. K. Dundas

LIMITED

Experimental and Aeronautical Engineers and Scientific Instrument Makers. Manufacturers of Precision Mechanical, Electro-Mechanical and Thermionic Instruments. Electro-Medical and Industrial Apparatus, Time Interval Measurement and Counters, DC Amplifiers and Recorders. Specialised Design Enquiries Welcomed

THE AIRPORT, PORTSMOUTH

Telephone : 74874.

Wanted

CONVERTER required for radio, dc to ac.—Tel. Redfern, Fulham 0278. [2427]
WANTED, rotary converter, any size.—Hull, 221, City Rd., London, E.C.1. [2428]
TEST EQUIPMENT
COSSOR oscillator and oscilloscope for sale, both as new.—Box 3050. [2441]
NEW Avon all-wave a.c. oscillator; offers.—12, Highcliffe Drive, Sheffield. [2459]
NEW Universal Avomitor, £9, exchange all-wave oscillator, G12 duode.—Box 3061.
COSSOR oscilloscope, 4 1/2 in tube, £20; Cossor gauging oscillator, a.c., £15; both good condition.—40, Tower Rd., Epping. [2407]
TESTOSCOPE used everywhere by radio service engineers, makes 20 important tests; send for interesting leaflet "R.I."—Rinbaken, Manchester, 1. [1074]
TAYLOR, 0-1 mA meters, 3 1/2 in scale, with 5mA rects, new unused, 6gns.; 5in lathe, ac motor, chuck, tool rest, etc., 10gns; send stamp for bargains.—Box 3043. [2409]
COSSOR model 3402 9in double beam oscilloscope, new, unused, comp. except for C.R.T., which is still avail.; Deposit system; £50 or offer.—"Solars," Chiddingfold, Surrey.
MULLARD Master valve test-board, type 7629, with large number of test cards and instructions at £65.—Wallace Heaton, Ltd., 127, New Bond St., London, W.1. [2460]
MACLACHAN all-wave oscillator, calibration graph; also R. and C. bridge, similar Scroggies; offers.—Goodsell, "Woodside," Eldred Ave, Brighton, 6, Sx. [2492]
EVERSHED Megger circuit testing ohm meter £5/10; dynamometer valve tester, £8/10; Rothermel Brush crystal tweeter, 25/-.—92, Grange Park Rd., Thornton Heath.
TAYLOR model 301 meter, 0-0.8 ma, 2 1/2 in dial, new, £4; wanted, precision 5- or 6-gang condenser, 300-500 mmfd sections.—Lewis, 138, Maidstone Rd., Rochester, Kent.
RESISTANCE capacity bridge, with milliammeter, magic-eye indicator and neon leakage test, own power supply; Oscilloscope, 5in tube, 1,000v power supply; quantity valves, meters, etc.—Box 3049. [2436]
HUNDREDS of voltmeters and ampmeters in stock by well-known makers, Weston, G.E.C., N.C.S., etc., mostly 6in and 8in surface switchboard types; prices from 30/- to £3 each; also a few smaller meters; please note ranges available—volts 0-10 to 0-150, amps 0-1 to 0-2,000, milliamps 0-50 to 0-1,000; all in a.c. and d.c. types; few multi-range and recording types.—Harris, Strouds, Bradford, Berks.
WANTED, all-purpose meter.—Full parties. to Allen, 10 Queens Rd., Sale, Ches. [2495]
E.M.I. 20,000 o.p.v. meter; Marconi impedance bridge (T.F.373); E.M.I. valve voltmeter; Hickhok traceometer, Box 3053.
WANTED, 1 milliammeter 0.1 milliamps, or also any type of universal Avomitor or Avometer.—Bloom, 35, Cranwick Rd., Stamford Hill, N.16. [2495]
RIDER Chanalyst, oscillograph and signal generator.—Full particulars to Godfrey Industries, Ltd., Brundall, Norwich. Tel. Brundall 70. [2471]
NEW MAINS EQUIPMENT
EVERETT Edgcombe automatic voltage regulator for 230 volts 50 cycles, vibrating contactor type, £6.—Harris, Strouds, Bradford, Berks. [2465]
VORTEXION mains transformers, chokes, etc., are supplied to G.P.O., B.B.C., L.P.T.B.; why not you? Imitated but unequalled; orders can only be accepted against Government contracts.
VORTEXION, Ltd., 257, The Broadway, Wimbledon, London, S.W.19. Lib. 2814.
WESTINGHOUSE H.T.111 with Heybeard transformer, input 210-250, output 350 volts d.c., 120 in amp, four 2mf smoothing condensers, 4,000 volt wkg., Ferranti flush voltmeter, reading 150 volts, 1,000 ohms p.v., as new.—Box 3058. [2479]
BATTERY chargers for a.c., no valves; commutating rectifiers, 230 volts, input 15 volts 5 amps out, £12/10; 25 volts 6 amps, £15; 6 volts 1/2 amp, £4; rotary converter, 200v a.c., in 16 volts 24 amps, d.c. out, £22; chargers for d.c., 220v in, 15v 4 1/2a out, £4; 220v in, 12v 12a out, £5; 250v in, 7 1/2v 50 amps out, £17.—Harris, Strouds, Bradford, Berks. [2467]
Wanted
WANTED, Westinghouse metal rectifier, either L.T.5, L.T.41 or L.T.44, second-hand, good condition.—Box 3066. [2511]
MORSE EQUIPMENT
MORSE practice equipment for class-room or individual tuition; keys, audio oscillators for both battery or main operation.—Webb's Radio, 14, Soho St., London, W.1. Tel. Gerrard 2089. [2291]
GRAMOPHONE AND SOUND EQUIPMENT
GARRARD univ. motor, 11.5, with 12in turntable, new, auto-stop; £6.—Box 3046.

AUSTERITY RADIO LIMITED

Formerly F. H. Wilson
CONSTRUCTORS' KITS

3-v.

T.R.F.

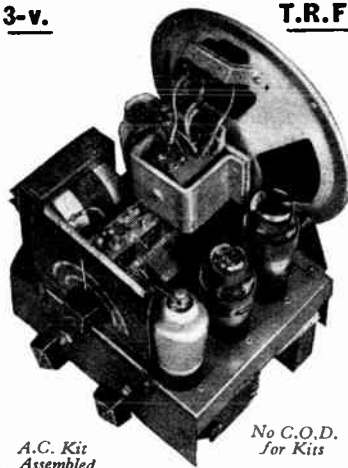

A.C. Kit Assembled.

No C.O.D. For Kits

Delivery approximately One Month.

When assembled these Kits give excellent reproduction on Medium and Long Waves. Supplied complete with chassis, 8in x 8 1/2 in x 2 1/2 in. Valves, M.C. Speaker and wiring diagram. (Regret, no cabinets.) 3 controls. A.C. 3-V. (+ RECTIFIER) KIT. V.M.H.F. Pen., Triode, L.F. Pen., Rectifier, M.C. Speaker. Price 10 gns. Post 1/1, plus 3/6 packing (returnable).
BATTERY 3-V. KIT. V.M.H.F. Pen., Triode Detector and Output Tetraode, P.M. Speaker. Price 27. Post 1/1, plus 3/6 packing (returnable).

3-GANG CONDENSERS, ceramic insulation, .00025, 8/6; also STANDARD .0005 ceramic insul., 12/6.

SHORT-WAVE COILS, 3 bands covering 12-50 metres. Aerial and H.F. mounted on screened switch. Wired up to terminal output connections. All numbered. 1 1/2" spindle. Complete with circuit. 20/-.

A. & H.F. TRANSFORMERS with reaction colour coded. 10/6 a pair.
SCREENED DUAL RANGE COILS, Long and Medium. Aerial and H.F. Transformers with reaction. Size 2 1/2 dia. x 3 1/2 in. Iron-cored on medium wave only. With circuit blue print. 12/6 a pair.

465 KCS. L.F. TRANSFORMERS, Iron-cored, screened, with trimmer, 15/- a pair. Air-cored, unscreened, small, 15/- pair.
UNIVERSAL MAINS TRANSFORMERS, A.C. input, 230 v. output, 300-0-300, 6.3 v., 4 amp., 5 v., 2 amp., 4 v., 2 amp., 4 v., 4 amp., 80 ma. Screened primary colour coded—a good replacement transformer, especially for sets using mixed valves. 32/6 each.

STANDARD REPLACEMENT MAINS TRANSFORMERS, input 200/250 A.C., output 350-0-350, 80 m.a., 4 v., 4 amp., 4 v., 2 amp. Screened primary, 30/- each.

STANDARD MAINS TRANSFORMERS, input 200/250 A.C., output 350-0-350, 160 m.a., 6.3 v., 5 amp., 5 v., 2 amp., 35/- each.

MAINS VOLT DROPPING RESISTORS, 3 amp. 1,000 ohms, 2 variable sliders, 6/-; 3 amp. 760 ohms, 2 variable sliders, 7/-.
10-WATT WIRE-WOUND RESISTORS, 2,000, 1,000, 500 and 150 ohms, 2/6 each.
PADDERS, Twin ceramic .0005 mfd. and .001 mfd. (max.), 2/6 each.

VOLUME CONTROLS, 1, 1, 1 and 2 meg., with switch, 6/6 each. 6,000, 10,000, 25,000 and 50,000 ohms, less switch, 4/- each.
COMBINED VOLUME CONTROL, 100,000 ohms and Reaction Condenser, 6/6.

CHASSIS, Undrilled steel, painted, new, 10 1/2 x 8 x 2 1/2 in., 7/6; 8 x 6 x 2 1/2 in., 4/6 each.

★ Please add postage for enquiries and orders, C.O.D. orders accepted.
 Licence to export to Northern Ireland and Eire. Owing to present circumstances, prices are subject to increase without notice.

307, HIGH HOLBORN, LONDON W.C.1. Phone: HOLborn 4631

SEXTON'S for SALES, SERVICE, SATISFACTION

ELECTRIC IRONS for 100/110 volt, 200/220 volt, 230/250 volt, AC/DC mains, 3-3½ lbs. weight, strong wooden handle with plated dome, connector guard and rest, ground and polished sole plate, complete with fit. flex at 28/6 each.

AMERICAN LEASE LEND RADIO VALVES. Most popular types available at Board of Trade Controlled Prices.

BRIVARON RADIO VALVES. British made, types as follows: RF.120, equivalent to Marconi U.12, 80 equivalent to American 80. 5Y3 equivalent to American 5Y3. 5Y4 equivalent to American 5Y4. RF.40 equivalent to ID5 or URIC at 11/- each. Postage 4d.

LINE CORDS. 3-way, best quality, 360 ohms at 8/6. 480 ohms at 10/6. 600 ohms at 13/6. 2-way, best quality, 350 ohms at 7/6. 450 ohms at 9/6. 600 ohms at 12/6 each.

EXTENSION LOUD SPEAKERS. Permanent magnet.

"Rola" 3 ohm voice coil, less trans., size 5in. at 21/6, with trans. at 26/6.

"Rola" 3 ohm voice coil, less trans., size 6in. at 22/6, with trans. at 27/6.

"Rola" 3 ohm voice coil, less trans. size 8in. at 24/-, with trans. at 29/6.

"Celestion" Model CT.104, 8in. chassis with Universal trans. 3 watts at 36/-.

"Celestion" Model CT.108, 8in. chassis with Universal trans. 5 watts at 48/-.

"Goodman's" 3½in. 12 ohm. voice coil, ideal for microphones, communication sets, etc., at 25/- each.

ELECTRIC IRON ELEMENTS. Universal 200/250 v. AC/DC mains at 2/6 each.

TERMS: Cash with Order only. Send Id. stamp and stamped addressed envelope for latest list of electrical appliances and radio.

J. E. SEXTON & CO. LTD.

164, Gray's Inn Road, London, W.C.1.
Tel: Terminus 1304 & 4842.

COILS for filters, tone controls, etc., all types transformers for "W.W." circuits.

-R. Clark, 30, Langland Cres., South Stanmore, Middx. [2275]

AMPERITE ribbon microphone, on chrome stand, £15; E.M.I. p.m.201 moving coil microphone on chrome stand, £14.-Harris, Strouds, Bradford, Berks. [2468]

PRESTO Jr. portable recorder, with amplifier and crystal pick-up, complete, as new, and 6 12in D.S. discs, £100.-Benson, Bush Barn, Robertbridge. [2447]

RECORDING cutters.—We can supply first class steel cutters at 8d. each; cash with order only.—The Bishop Sound and Electrical Co., Ltd., 108, Beverley Way, London, S.W.20

RECORDING engineer offers consulting service for disc-film-tape, etc.; advice, diagrams; tests and reports; general design and information all aspects of sound recording.—S.a.e. with enquiries BM/DFAD, London, W.C.1

OFFERS for pick-ups, Jones m/coil with transformer and corrector, Marconi magnetic and Cosmoord; also G.E.C. gramophone ac/dc motor and turntable, and few Telsen h.f. unscreened transformers or aerial coils; all as new.—Box 3042. [2403]

AUTO-TROPE radio gram chassis, complete consisting 4-waveband receiver chassis, rack type amplifier, with 3 stages of resist. coup. push-pull, using M14 valves, final stage PX25s. with two rect., 1 G 12 energised speaker and 1 Magnavox 33 ditto; autochanger built on tubular chas. chrom. plated, independent motor for changing mechanism; play either one or both sides record; best offer secures.—Rockalls, Rustington, Sussex, Tel. Rust. 433.

PUBLIC address equipment by G.E.C., all brand new, surplus to requirements, amplifiers 14 watt, BCS 2216, £24; 60 watt BCS 2230.2, £56; microphones, BCS 2285 m/c, 110/-; BCS2274 carbons, 70/-; 14 industrial metal speakers, 75/-; 12 cabinets, BCS1937, 52/6; 8-10 watt Farnell amp, £15; fitted bakelite junction boxes, 11/6 and 13/- per dozen.—N.E. (Sales), Ltd., 48, Prestongate, Hessele, Yorks. [2497]

Film Industries portable amplifiers, each provided with 2 input circuits, gramophone and moving coil microphone, arranged with change-over switch, also introduces frequency compensating (bass boosting) circuit in gramophone position; microphone transformer incorporated in amplifier; 2 output plugs for 4 ohms and 8 ohms impedance; battery consumption (12 volts); rotary converter, HT power output 10 watts; size 6½in x 10¼in x 10½in high; weight 2½lb; price, complete with valves and plugs, each £26/10. plus carriage; ideal for police cars, fire engines, electioneering purposes, air raid warning vehicles, lifeboats, ambulances, passenger service vehicles; 40in all-metal horns with 1.5 7 unit, 12gns each.—Larg's, Whitehall St., Dundee. [2437]

Wanted

WANTED, steel tape sound-recording apparatus.—Box 3067. [2513]

AUTO-CHANGE record unit, good condition.—Paul, 30, Thurlow Place, London, S.W.7.

RECORD changer, late model, perfect.—James, 40, Robertson Rd., Bristol, 5.

ROTHERMEL crystal microphone, B1 BR2S or AR12, second hand.—Reid, 97, Helgrave Rd., London, S.W.1. [2486]

COMPONENTS—SECOND-HAND, SURPLUS FOR sale, 300 American submidget tone controls, ½ meg.—Box 3063. [2501]

NEW 5-band 3-stage superhet coil units, 25/- each (stamp parties); Celestion 8in P.M.S. trans. 26/6.—BM/ZDDP, W.C.1. [2506]

SPEAKERS, P.M., 8in, less trf., 21/-; chassis inc. 8 v. holders, I.F.s., resistors, etc., 25/-; other bargains; s.a.e.; list.—Box 3051.

ALL radio enthusiasts will find much to interest them at Berry's (Short Wave), Ltd., 25, High Holborn, W.C.1 (Tel. Holborn 6231), or a 1d. stamp will bring the latest list.

IT would be an exaggeration to say we have everything in radio, but we have nearly every valve, resistance, condenser, etc.; pay us a visit, it will save you a lot of time.—Berry's (Musical), Ltd., 10, London Rd., Camberley, Surrey. [2454]

SPECIAL offer, line cord, British made, super quality, 3 core 0.3 amp 80 ohms per foot at 6/9 per yard; also 2 core 0.15 amp 100 ohms per foot at 5/6 per yard. c.w.d. or c.o.d.—J. Bull and Sons, 246, High St., Harlesden. [2488]

K. H. EDE, "Eureka," Surrey Gardens, Effingham, Surrey.—C.w.o. No c.o.d. under £1, please. Celestion 8in p.m. speakers with trans., 27/6 ea.; Centralab v.c., less switch, long spindles, 1 meg., 3/4 ea.; resistances, ¼ and ½ watt, 8 useful values, 3/6 doz; Dubilier flat wire end mica cond., 0.0001 50/- ea., 4/6 doz; valves, type 5Y3, 5/6 ea.; special bargain! 110k0 if. trans. and oscillator coils, leads marked, ex-Ekco, 10/- per set; 3 gang tuning cond. for use with above, 3/6 ea.



Yours to a tenth of a thou'

Precision Engineering production calls for up-to-date machines and a highly skilled staff. These, of course, we have, but—in light Engineering products especially, delivery dates are most useful when they are adhered to. YOU know that—so do we.

Wingard
(MA) LTD.

Precision Engineers
EUGENE WORKS, EDGWARE ROAD, HENDON, N.W.9



W. BRYAN SAVAGE
LTD.

Expert assistance in the solution of problems relating to

● TRANSFORMERS, CHOKES
● AMPLIFIERS
● POWER UNITS

and Specialised Equipment embodying

ELECTRONIC CONTROL

WESTMORELAND RD., N.W.9
COLINDALE 7131

AFTER THE WAR!

The advance in Radio Technique after the war will offer unlimited opportunities of high pay and secure posts for those Radio Engineers who have had the foresight to become technically qualified. How you can do this quickly and easily in your spare time is fully explained in our unique handbook.

Full details are given of A.M.I.E.E., A.M.Brit.I.R.E.E., City & Guilds Exams., and particulars of up-to-date courses in Wireless Engineering, Radio Servicing, Short Waves, Television, Mathematics, etc., etc.

We Guarantee "NO PASS—NO FEE"

Prepare for to-morrow's opportunities and post-war competition by sending for your copy of this very informative 112-page guide NOW—FREE.

BRITISH INSTITUTE OF ENGINEERING TECHNOLOGY (Dept. 388)
Stratford Place, London, W.1

LONDEX for RELAYS

The wide range of Londex Relays includes a variety of

TYPES APPROVED

by
**AIR MINISTRY
M.A.P.
ADMIRALTY**

Ask for details and leaflet SPN/WW.



Multiple contact Relay LF.

LONDEX LTD

MANUFACTURERS OF RELAYS
ANERLEY WORKS 207 ANERLEY ROAD LONDON S.E.20

Become a W/T Operator!

Skilled W/T Operators are required in practically every branch of the Services—Army—Navy—Air Force as well as for the Mercantile Marine. Many who would like to become W/T Operators are located too far away from the few schools which they might attend, whilst others cannot spare the time taken to travel to and from classes.

THE CANDLER SYSTEM OF MORSE CODE TRAINING IS CARRIED OUT IN YOUR OWN HOME

The excellence of Candler Code Courses has accounted for the success of many thousands of present-day operators. Many readers of "The Wireless World" are taking Candler Courses.

MOST IMPORTANT

J. Clarricoats, Sec., Radio Society of Great Britain, says:—

"I regard the Candler System as being the most important system of its kind and already large numbers of Members of the Radio Society of Great Britain have intimated to me that they are studying the course of instruction with a view to preparing themselves for service in one branch or another of H.M. Forces."

There are Courses for **Beginners and Operators**. Full details are given in the Candler "Book of Facts," Free for a Postcard request. Write to:—

THE CANDLER SYSTEM CO.
(Room 55.W), 121, Kingsway, London, W.C.2.
Candler System Co., Denver, Colorado, U.S.A.

PREMIER RADIO

Premier 1-Valve de Luxe Battery Model S.W. Receiver, complete with 2-volt valve, 4 coils covering 12-170 metres. Built on steel chassis and panel, Handpiped tuning, 55/-, including tax.

PREMIER MICROPHONES

Transverse Current Mike. High-grade large output unit. Response 45-7,600 cycles. Low hiss level, 23/-.

Premier Super-Moving Coil Mike. Permanent Magnet model requiring no energising. Sensitivity 66db. Impedance 25 ohms. Excellent reproduction of speech and music, £5/5/-.

Microphone Transformers, 10/6 each. Crystal Mike. Response is flat from 50-5,000 cycles with a slightly rising characteristic to 8,000 cycles. Output level is minus 60db. Price 39/6.

Chromicon Collapsible Type Microphone Stand, 52/6.

CHASSIS

Lead coated steel, undrilled.
 10 x 8 x 24" price 7/- each.
 16 x 8 x 24" price 8/6 each.
 20 x 8 x 24" price 10/6 each.

I.F. TRANSFORMERS, IRON CORED 450-470 kc/s, plain and with flying lead, 7/6 each.

NEW PREMIER S.W. COILS

4- and 6-pin types, now have octal pin spacing and will fit International Octal valve holders.

4-PIN TYPE
 Type Range Price
 04 9-15 m. 2/6
 04A 12-26 m. 2/6
 04B 22-47 m. 2/6
 04C 41-94 m. 2/6
 04D 76-170 m. 2/6

6-PIN TYPE
 Type Range Price
 06 9-15 m. 2/6
 06A 12-26 m. 2/6
 06B 22-47 m. 2/6
 06C 41-94 m. 2/6
 06D 76-170 m. 2/6

CHASSIS MOUNTING
 OCTAL HOLDERS
 104d, each.
 New Premier 3-Band S.W. Coil, 11-25, 25-38, 38-86 m., 4/9.

Rotary Wave Change Switch, to suit above, 1/6.
Bakelite Dielectric Reaction Condensers.
 0001 mf. 1/3, 0003 mf. 2/6, 0005 mf. 2/9 each
 0003 mf. Differential 2/11 each

H.F. CHOKES

S.W. H.F. Choke, 10-100 m. 1/3
 Binocular H.F. Choke 1/6
 Brass Shank Coilers, 1in. bore 7id. each
 Flexible Coilers, 1in. bore 1/6 each

7-pin Ceramic Chassis mtg. English fitting Valve Holders, 1/6 each.
Amphenol Octal Chassis mounting Valve Holders. International type, 1/3 each; English type Octal, 1/3 each.

RESISTANCES

Mains Resistances, 680 ohms, 5A Tapped. 360 x 180 x 60 x 60 ohms, 5/6 each.
 1,000 ohms, 2A Tapped. 900, 800, 700, 600, 500 ohms, 5/6 each.

SWITCHES

QMB, panel mounting, split knob type, 2 point on/off, 2/- each. Double pole on/off, 3/6 each.

VOLUME CONTROLS

Carbon type, 20,000 1 meg. and 3 meg., 3/9 each.
 5,000, 10,000, 4/6 each.
 Wire Wound Type, 5,000 and 10,000 ohms, 5/6 each.

Valve Screens for International and U.S.A. types, 1/2 each.
Resin-Cored Solder, 7id. per coil.
Push-Back Connecting Wire, 2jd. per yard.
Systoflex Sleeving, 2 mm., 2/6 per doz. yards.
Screened Braided Cable, Single, 1/3 per yard.
Twin, 1/6 per yard.

MOVING COIL SPEAKERS

Goodmans 3 1/2in. P.M. Speaker, 15 ohms voice coil, 30/-.
 Rola 3 1/2in. P.M. Speaker, 3 ohms voice coil, 25/-.
 Rola 3in. P.M. Speaker, 3 ohms voice coil, 25/-.

Above speakers are less output transformer.
 Pentode Output Transformers, 3 1/2 watts, price 10/6 each.

Collection 3in. P.M. Speaker, 28/8.
 Collection 10in. P.M. Speaker, 49/6.
 The above speakers are fitted with output transformers.

Morse.—The Premier Oscillator supplied complete with valve, on steel chassis, price 27/6. Practice key 3/3, TX key 5/10, Super key 11/6. 3-Henry Chokes (as used in Oscillator), 13/-, High pitched Buzzer, adjustable note, 1/11 each.

Send for details of other Accessories available.

ALL ENQUIRIES MUST BE ACCOMPANIED BY A 2jd. STAMP.

PREMIER RADIO CO.

ALL POST ORDERS TO:
JUBILEE WORKS, 167, LOWER CLAPTON ROAD, LONDON, E.5. (Amherst 4723.)

CALLERS TO:
JUBILEE WORKS or 169, FLEET STREET, E.C.4. (Central 2833.)

The New
"PYROBIT"
SOLDERING IRON



for Precision Instrument Work
 Can be operated like a pencil

With only 45 watts a Bit Temperature of over 300°C is obtained

For all Voltages from 6—250 volts.

The ACRU ELECTRIC TOOL MFG. CO. LTD.
 123 HYDE ROAD
ARDWICK, MANCHESTER, 12
 Telephone: ARDwick 4284

YOU can become a first-class RADIO ENGINEER

We are specialists in Home-Study Tuition in Radio, Television and Mathematics. Post coupon now for free booklet and learn how you can qualify for well-paid employment or profitable spare-time work.

T. & C. RADIO COLLEGE
 2 The Mall, Ealing, W.5

(Post in unsealed envelope, 1d. stamp.)

Please send me free details of your Home-Study Mathematics and Radio Courses.

NAME

ADDRESS

W.W.28

G. A. RYALL, 69, Wharfedale Gdns., Thornton Heath, Surrey.—Please note new temporary address; mail order only; no c.o.d. under 20/- please.

T.C.C. 0.1 non-induct. tubul. condensers, in pax tubes, type 330, 350 wks., 7/6 doz.

SLOW motion (epicycloid) drives, in well finished brass, ratio 8:1, shaft 1 1/2 in long. 1 in dia., drilled to take pointer, 1/3 each.

PAXOLIN strip, 2 1/2 in wide, 12 in lengths. 3 1/6 and 100 25/-; short lengths cut group board size, 6 1/3.

THIMBLE top caps, 24 1/3; insulating tape, black, 1/3 lb; Wearite switches, ebonite with silver-plated contacts, for 2nd and band pass, with dial lights, 1/6 each.

5-PIN plugs and sockets, complete with metal insulated cap, 2 for 1/6.

DIAL plates, oblong, 5 1/2 x 2 1/2 approx., Burndept, Varley, Vidor, with station names, 4 assorted for 1/6.

BURNDEPT portable set dials, 4 1/2 in x 2 in approx., two types, 2, 1/3; Burndept 4-band, 8 x 5 1/2, s.w. on lower half dial, 1/6 each; Vidor 3-band, 6 1/4 x 5 1/2, 1/6 each.

COILS, iron core, midget, Litz wound. Medium wave tapped, no reaction, 2/3 each; push-back wire stranded, cotton covered, 3 colours, 12 yards, 2/3.

MICROPHONE capsules by Standard Telephones, 3/9 each; Centralab volume controls, less switch, long spindles, 5,000 ohms. 1/4 meg, 1/2 meg, 3/9 each.

CENTRALAB volume controls, short spindle, 1/2 meg, less switch, unused, 2/10 each; twin screened, flexible, 1/3 yard; ditto, high insulation and cotton outer cover, 1/9 yard; ditto, 4-way, 2/3 yard.

LITZ: colour coded resistances, 2-watt type. £ 680, 6,800, 140,000, 150,000, 220,000, 470,000, 820,000, 2, 1/6; Erie 5-watt, 680, 6,800, 1/3 each.

TEN-WAY cable, 2/- yard; ditto with three 5 amp conductors, 3/- yard; tough flexible rubber cable twin conductors, 1/3 yard.

YAXLEY type low loss switches, single pole double throw, 2 bank 2/9, single bank 2/3; octal plugs with base, 8-pin, complete with insulated metal cap, 1/3 each.

CLYDON and Plessey trimmers, 70mm, 2, 1/6; 1,000 and 2,000mm, 2, 1/-; low value oddments, 2, 1/-.

MORGANITE volume controls, with switch, small type, long spindles, 1/2 meg, 5/- each; 10,000 ohm, less switch, 3/9; Sator, 50,000, with switch, 5/9.

INPUR strips, 2in x 3/4 in, 2-way, 2/9 dozen; with terminal screws, 3/9 dozen; anchor or mounting strips, 2/3 dozen, 5-way.

SPECIAL offer of T.C.C. double mica condensers, 0.0001 x 0.0001 x five (ten condensers) for 1/3; Hunts 0.01 mica condensers, 1/- each; hf chokes on ebonite bobbins, 5,000 ohms, 1/3 each. [2434

EXPERIMENTER'S surplus gear for sale, valves, power packs, condensers, resistors, coils, transformers, vol. controls, etc.; e.s.e. for details.—Box 3047. [2423

LONDON CENTRAL RADIO STORES.—See our displayed advert., page 17, this issue.—London Central Radio Stores, 23, Lisle St., London, W.C.2. Ger. 2969. [2359

LASKY'S RADIO, 370, Ilarrow Rd., Paddington, W.9, offer for sale the following components: special bargains for set builders: grey cellulosed steel radio chassis, complete with i.l. and aerial coils, trimmers, condensers, a and earth sockets, 8 valve holders, resistors, and many various components, etc.; size 8in x 2in x 1 1/2 in; special offer, 24/6 post free. 0.02mfd 2,000v at 1/- each; 0.25mfd 2,000v 1/6 each; 0.05mfd 500v at 1/- each; 2mfd 600v block at 2/6 each; 50mfd 12v at 1/4; 10mfd 25v at 1/6 each; 0.1mfd 350v at 6d. each; speakers, Rola p.m., 5in, at 19/6; 6 1/2 in at 21/-; 8in at 23/6; all less transformer; Goodmans' 3 1/2 in at 27/6. 5in at 21/6; special offer 10in at £2/5, post extra; send us your requirements. [2463

ELECTRIC soldering irons, pencil bit, 12/6; resin core solder, 1lb 4/6; 18g tinned copper wire, 1/4lb, 2/-; 2mm sleeving, 2/9 doz yds; pushback wire, 1/9 doz yds; heavy twin mains flex, 7/6 doz yds; rubber-covered 3mm flex, 1/9 doz yds; 50mfd 12v electrolytics, 1/6; 10mfd 50v can type, 2/9; 0.2 amp 1,000 ohm droppers, adjustable, 4/-; 0.3 amp 750 ohm, adjustable, 5/6; American octal valve holders, 8d.; British 7-pin, 8d.; 0.1mfd 350v condensers, 6/6 doz; black set knobs, 7/- doz; solder tags, 2/- gross; "Clix" 2-pin plugs, 5 amp, 1/-; 3-pin 5 amp, 1/3; 3-pin 15 amp plugs, 2/6; BC adaptors, 1/3; volume controls, long spindles, all usual values, 3/6; with switch, 4/6; top cap connectors, 1/- doz; screened type, 8d. ea.; octal or standard; insulation tape, 1/4lb 1/-; large stocks American valves, etc.; orders above 10/- post free; mail order only.—"A. H.," Hazeljohn, Crofton Lane, Orpington. [2438



Any Size

Low in cost
Require no attention
No lubrication
No adjustment
Cushion shock
Prolong life
Transmit power
No wear
Designed to eliminate vibration

You are certain to be interested in this unique constructed in flexible bearing.

THE RUBBER AND METAL ARE ONE UNIT AFTER WELDING OR BONDING.

CLAYFLEX
FLEXIBLE BEARINGS

CLAYFLEX LTD.
TIDDINGTON RD., STRATFORD-ON-AVON
PHONE: STRATFORD-ON-AVON 3296/7
GRAMS: CLAYFLEX, STRATFORD-ON-AVON

"ENGINEERING OPPORTUNITIES"



This unique handbook shows the easy way to secure A.M.I.Mech.E., A.M.Brit.I.R.E., A.M.I.E.E., City and Guilds, etc.

WE GUARANTEE— "NO PASS—NO FEE."

Details are given of over 150 Diploma Courses in all branches of Civil, Mech., Elec., Motor, Aero, Radio, Television and Production Engineering, Tracing, Building, Govt. Employment, R.A.F. Maths., Matriculation, etc.

Think of the future and send for your copy at once—FREE.

B.I.E.T., 387, SHAKEPEARE HOUSE
17, STRATFORD PLACE, LONDON, W.1.

THE AMBASSADOR P.A.143



FOR INDUSTRIAL EDUCATIONAL AND WELFARE NEEDS

Is the best selling line in P.A. equipment. With built-in radio unit £28.10s. (subject) + 25% TAX Industrial speakers (10") £3.12s. (subject)

Catalogue and terms on request.

R. N. FITTON LTD
HUTCHINSON LANE, BRIGHOUSE
Scottish Distributors: Tel.: 283
British Electrical & Manufacturing Co. Ltd.
133, West Campbell Street, Glasgow
Tel.: Central 3286

E.D.C. rotary converter, 24v dc to 230v ac 60-100w radio filter, silence cabt., as new, £15; adaptor in flat cabinet (to stand set on). MH4 valve, circuit, new, 50/-; wtd., 230v ac gramo. motor or Simpson turntable.—Worden. Lightfoot Lane, Broughton, Preston. [2490]

COULPHONE RADIO, New Longton, nr. Preston.—New goods only; Tungram and B.V.A. valves; mains transf., 350v, 100 ma. 4v 6a, 4v 2.5a, 6.3v 3a, 5v 3a, 33/6; mains transf. bobbins, windings as above, 18/6; n.m. speakers, less transf., Rola 5in 21/6. 6½in 22/6. 8in 24/-. Plessey 10in, powerful magnet, 35/-. Celestion, with pen. trans., 8in 30/-. 10in, heavy duty magnet, 45/-; power-pen. output transf, 7/6; push-pull Universal, 15/6; Paraflex I.I. transfs., 4:1, 6/6; Bell transfs., 6/6; line cord rep. resistors, 800 ohm, 2 adj. taps, 6/9; push-back wire, 100ft 6/-; carbon resistors, ¼w 4d., ½w 6d., 1w 9d.; switch cleaner, 2/3 bott.; cellulose cement, 4/-; apt. rored solder, 4/6lb tin; cop. wire, 2/3 ¼lb; sleeving, 2mm, 3d. 7d; condensers, 50mfd 12v, 25mfd 25v, 2/-; 25mfd 50v, 2/9; tubular and silver mica, all sizes; valve holders, 1d. per pin; vol. controls, with sw., 5/9; less sw. 4/9; smoothing iron elements, 450w, 2/3; fire spirals, 750w, 2/-; 1,000w 2/6; s.a.e. for stock list. [2417]

SOUTHERN RADIO'S wireless bargains: Screws and nuts, assorted gross of each (2 gross in all), 10/-; soldering tags, including spade ends, 6/- gross; Philco 3-point car aerials, excellent for short-wave and home aerials, 7/6; Limit tone arms, universal fitting for all types of sound boxes and pickup heads, 10/-; Ace "P.O." microphones, complete with transformer, ready for use with any receiver, 7/-; circular magnets, very powerful, 1½in diameter, by ¾in thick, 1/6 each, 15/- per doz.; Erie resistances, brand new, wire ends, all low value from 0.8 ohms upwards, a few higher value are included in each parcel, ¼, ½, 1 and 2 watt, 100 resistances for 30/-; Multicon Master mica condensers, 28 capacities in one from 0.0001, etc., etc., 4/- each; special assorted parcel for service men, 10/-; Erie resistances (description above), 24 assorted tubular condensers, 8 reaction condensers, 0.0001, 12 lengths insulated sleeving, 75ft. push-back connecting wire, soldering tags, screws, wire, etc., 65/-, all brand new; crystals (Dr. Cecil), 6d., with cats-whisker, 9d.; complete crystal detectors, 2/6; 75ft. wire for aerials, etc., 2/6; 25yds push-back wire, 5/-; Telsen reaction condensers, 0.0001, 1/9 each; Telsen large disc drives, complete with knob, etc. (boxed), type W 184, 2/6 each; insulated sleeving, assorted yard lengths, 3/6 doz.; single screened wire, doz. yards, 10/-; loud speaker units, unshrouded, midget type, 4/-; metal case condensers, 0.1 +0.1+0.1, 2/6; rheostats, power type, 30 ohm, 4/6; pointer knobs, black and brown, ¼in. 1/-.—Southern Radio Supply Co., 46, Lisle St., London, W.C. Gerrard 6653. [2152]

CABINETS

NEW and modern design loud-speaker cabinets, fitted with loose baffle boards, size 13in×12in×7in, polished oak or w.t. unit, in stock for immediate delivery, 17/6 each; any type or design of cabinet made to order, wholesale only.—Send your enquiries to Waldenberg Bros., Ltd. (est. 1896), New York Rd., Leeds, 2. Tel. 22490. [2249]

VALVES

2000 valves, British and American; send stamped addressed envelope for list.—Napiers, 127, Prestwick Rd., Ayr. [2421]

5000 valves, all types, including output, rectifiers, etc.; also a few tax-free ones left; s.a.e.—Davies, 28, Mount Vernon Crescent, Barnsley. [2406]

ANY British or U.S.A. valve, 10", c.o.d. only; EBL1, FC4, 6B7, 6A7, 6A8, VP4, 80, SP13, EF9, etc.—65, Carlton Mansions, Randolph Ave., London, W.9. [2482]

COULPHONE RADIO, New Longton, nr. Preston.—Tungram and B.V.A. valves, hundreds in stock; post and packing free; rectifiers 5Y3G, 5Z4G, 80, equiv. U12, U14, etc., 10/6; really prompt service; s.a.e. with enquiries. [2418]

LIMITED stock of standard valves available, L Mulart, AZ1, EBL1, Pen. A4, PM2B, Mazda, AC/HI/DP, C/VP1, JIL, 1320, UUS, VP 41, VP 210, VP 1322; Brinar 6A8G, 6F6G, 6K7G, 6Q7G, 9D2, 25A6G, 25Z4G; sent c.o.d.—Larg's, Whitehall St., Dundee.

VALVES—We have over 5,000 new and boxed English and U.S.A. mains and battery valves in stock, including 6A7, 6A8, 25Z4, 75, 5Z4, U50, 35Z5, 50L6, 35L6, 6F6, FC13C, VP2, SP4, PX4, PENA4, 125Q7, TDD4, UUS, 6K7, 117Z6, 6Q7, 6K8, 6X5, 6B8, 1W4350, U12, 12A8, 12Q7, 6SA7, 6SK7, PEN35c, etc.; send us your requirements.—Lasky's Radio, 370, Harrow Rd., Paddington, W.9 (opposite Paddington Hospital). [2462]

"UNIVERSAL CIRCUITS"

by R. S. Roberts, M.Brit.I.R.E., A.M.I.R.E.

Three folders and a thirty-six page booklet, presenting the main principles of radio circuit operation in a concise and convenient form for the pocket.

- I. The Transmitter.
- II. The T.R.F. Receiver.
- III. The Superheterodyne Receiver.

By means of hinged flaps, the charts give a large number of recognised alternatives for each stage. To assist the student in memorising and understanding these, a logical five-colour scheme has been adopted throughout.

"Grid Leak" says: "The Charts and Notes are really intended for students and teachers of radio, but are extremely useful to every radio engineer."

Price complete 6/3 post free, from

The Bookstall
NORTHERN POLYTECHNIC
HOLLOWAY, LONDON, N.7

SPEAKER REPAIRS by Specialists

Any make, British or American Best Service

TRADE ONLY Moderate Charges

Also Components for Service Men at keenest prices. List Id. Holders of Export Licence for Northern Ireland.

A. W. F. RADIO PRODUCTS 'Phone: 11926
Borough Mills, Sharpe Street, Bradford, Yorks.

WARD ROTARY CONVERTERS

Petrol Electric Generating Plants, H.T. Generators, D.C. Motors, Frequency Changers, etc., up to 25 K.V.A.

CHAS. F. WARD
37, WHITE POST LANE, HACKNEY WICK, E.9
'Phone: Amherst 1393

Radio Service

REWINDS. Mains from 25/-. Output from 6/-, Field Coils, 9/-. PROMPT DELIVERY.

VALVES (B.V.A.). Send for list—good select.

PHILIPS D.C. CONVERTERS—Bought—Sold—and Exchanged.

R.A.F. 50-1

A.D.S. Co. 261/3/5, Lichfield Road, ASTON, BIRMINGHAM, 6.

TESTSCOPE



Makes 40 important tests A.C./D.C. Used everywhere by Electricians, Wiremen and Service Engineers. Interesting booklet "T11" on testing, free. From all Wholesalers or direct.

RUNBAKEN -- MANCHESTER -- I

LOW VOLTAGE BULBS
FOR ALL PURPOSES

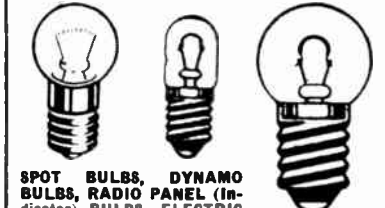

SPOT BULBS, DYNAMO BULBS, RADIO PANEL (Indicator) BULBS, ELECTRIC LAMPS, TORCH CASES, BATTERIES.

SUPLEX LAMPS LTD.

Appointed B. O. T. IMPORTER SELLING AGENTS
50, GRAY'S INN ROAD, LONDON, W.C.1.
Tel.: HOLBORN 0225

OUR adaptors will help in replacing unobtainable valves; send 7d for interesting booklet on valve replacements; trade enquiries invited.—V.E.S., Radio House, Ruislip.

1000 valves in stock.—CY1C, 11/-; UR3C, 11/-; U10, 11/-; VP23, 11/-; AC2/PenDD, 15/3; AC5/PenDD, 15/3; Pen DD4020, 15/3; VP13C, 12/10; SP13, 12/10; Pen A4, 12/10; 80, 11/-; 78, 12/10; 45, 11/7; 42, 12/10; U05, 11/-; U31, 11/-; 1W4/350, 11/-; HL23, 5/10; AC/TH1, 14/-; SP41, 12/10; EM3, 10/5; AZ1, 11/-; 36, 12/10; 6C6, 12/10; ICSGT, 11/-; IHSGT, 9/2; 35Z4GT, 11/-; send s.a.e. for valve and wireless parts lists, 2d.—Ransom, 9 and 34, Bond St., Brighton. Retailers not supplied. [2397]

VALVES, British and American, many types in stock; Midget aerial and hi coils, medium and long waves, ideal for midget T.R.F. receivers, 11/- per pair; Midget 2-gang 0.0005mfd variable condensers, fitted slow motion drive, 12/6; Midget receiver chassis, drilled for four valves, 10½x6x2in. grey, first class, heavy quality, 9/6; Midget speaker transformers, 7/6; standard speaker transformers for Pen output, 9/6; superior quality smoothing chokes, heavy duty, 120ma. 200 ohms, 15/-; 80ma. 500 ohms, 12/6; midget smoothing chokes, 50-60ma, 7/6; Midget knobs, highly polished, black, midget knobs, brown and standard knobs, 1¼in diameter, at 9d. each, 8/- doz; Midget rotary switch, s.p.d.t., 3/6; push back connecting wire, 3d. yard; dials, three wavebands, short, medium and long, station names, etc. in colours, ivorine, 7x4in. 1/6; special prices for quantities; replacement field coils for standard 8in m.c. speakers, 400 ohms, also useful as smoothing choke winding, 5/- 48/- doz; universal mains droppers for all receivers, 1,000 ohms, 0.2 amp, fitted two variable taps, 4/6; 750 ohms, 0.3 amp, do. taps, 5/6; heavy quality dropper, porcelain former, do. taps, fixing feet, superior job, 950 ohms, 0.2 amp, and 800 ohms 0.3 amp, 7/6 each; mains transformers, 350-350, 4v, 2 amp, 4/6; 4 amp, standard prim., and ditto, 6.3v 5.0v l.t., at 35/- each; superior class job; wire-wound potentiometers, 2,000 ohms, 6/6; condensers, tubular wire ends, 350v working, 0.1 and 0.01 mfd, 7/6 doz; Paxolin chassis mounting valveholders, British and American, 9d. each, 8/- doz; screened braided single core cable, 1/- yard; 2-way screened leads, braided insulation, 54in, fully finished, terminating four plugs for mike, gram, amplifiers, etc., 3/-; superior quality line cord, 50 ohms per foot, 3-way, 0.3 amp, 6/- yard; everything for the serviceman and experimenter, full range speakers, Rola 8in, p.m. less tran, 27/6; do. 8in, mains energised, less tran, 2,000 ohms field, 30/-; R. and A., 8in, mains energised, with Pen tran, 1,500 ohms field coil, 37/6; Celestion, 8in, p.m. with tran, 35/-; Midget speaker, 5in, p.m. with tran, 52/6; sleeving, etc., etc.; send for lists; licence to export to N. Ireland, stamped addressed envelope with all enquiries, please; postage on all orders.—O. Greenlick, 34, Bancroft Rd., Cambridge Heath Rd., London, E.1. Steppeny Green 1334.

Wanted

NEW boxed valves wanted, any quantity, dealers' and service men's complete stocks bought.—J. Bull and Sons, 246, High St., Harlesden, N.W.10. [2155]

REPAIRS AND SERVICE MIDWEST, McMurdo, Belmont, Crosley, Ferguson, etc., valves; the American experts—Bennett's, 4, Humberstone Drive, Leicester. [2478]

LOUDSPEAKER repairs, British, American, any make; moderate prices.—Sinclair Speakers, 170, Copenhagen St., London, N.1. Terminus 4355. [2415]

METROPOLITAN RADIO SERVICE Co. guaranteed repairs to American and British receivers.—1021, Finchley Rd., N.W.11. Sps. 3900. [964]

"SERVICE with a Smile"—Repairers of all types of British and American receivers; coil rewinds; American valves, spares, line cords.—F.R.I., Ltd., 22, Howland St., W.1. Museum 5675. [1575]

MAINS transformers service, repairs, rewinds, or construction to specification of any type, competitive prices and prompt service.—Etdurdy Electric Co., Ltd., Dipton, Newcastle-upon-Tyne. [9651]

DEGALLIER'S, Ltd.—Service with a guarantee. If you cannot get your receiver serviced, let American specialists do the job; first-class workmanship only; specialising in Air-King, Belmont, Challenger, Delco, Detrola, deWald, Emerson, Ferguson, Garod, Halli-crafter, Hammerlund, Lafayette, Meisner, McMurdo, Midwest, Majestic, Pilot, Philco, Player, Spartan, Stronberg-Carlson, Wells-Gardner, etc., also any British set; remember, for 14 years we have handled as distributors American receivers; this is self-explanatory; s.a.e. with all enquiries.—Degallier's, Ltd., 9, Westbourne Court, London, W.2.

ELECTRADIX

LABORATORY GEAR. Mirror Galvos, Sullivan Marine Reflecting vertical M.C. suspen., £9 10s. Tinsley Ballistic ditto, £6 10s. Mahog. Stand Scales for Spot use, £3 10s. Wheatstone Bridges and 142 m. Resistance boxes quoted for. A number of ex-W.D. Wheatstone Bridges, less coils, cheap. Circuit testing G.P.O. Vertical Galvos., 35/-. Mag. Ringer and A.C. Bell, 25/-. We can still supply Siemens High-Speed Relays, Meggers, A.C. Panel Voltmeters, Rotaries and Alternators, 10,000 ohm Relays, etc.

WAVEMETERS & RADIOGNOMETERS. We have some ex-W.D. Wavemeters, Buzzer and Heterodyne, less calibration chart, 45/- and 70/-. Radio Direction-Finders in mahog. cases, 90/-.

METAL CABINETS AND COVERS. Die cast aluminium boxes with hinged lid; inside 8½ x 4½ x 5½in., for oscillators, etc., 10/-. Covers. Light metal, ventilated special arch shape to contain 6½ x 5in. with terminal cover extension, 3/6. Crystal Sets for pocket or table.

SMALL SWITCHGEAR. Automatic Circuit Breakers, 10 amps. upwards, open or ironclad, triple pole, thermal trip, from 25/-. Battery cut-outs and Remote control D.C. contactors 6/12 volts 8 amps., type L, 10/6. 10 volts, 240 volts and 230 volts, 10 to 40 amps., 35/-. Rotary Instrument Switches, 7-way by R.I., ebonite panel, 7 studs on teak box, 7/6 only. Low voltage Switchgear, Lucas 8-way Aero enclosed, change-over and fuses, R.A.F. surplus, 3/6. 6-way R.A.F. push-button, 2/9. G.P.O. single c/o, 7/6. 3-way rocker switches, 3/6.

Bargains in Knife Switches, unmounted or on panel of enamelled slate, 24in. x 18in. Several 100 amp. size, each with porcelain handle, fuses fitted under. Bargain at 42/6 pair. Special Switch-panel, fitted 3 D.P. knife, 200 amp. switches with fuses and one pair of 60 amps., the whole panel, £6.

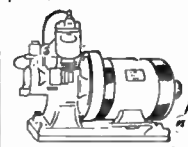

PETROL ELECTRIC PLANTS. 500 watt, direct coupled Stuart, 50 volts D.C. £45. **LIGHTWEIGHT ENGINES**, for direct coupling, Twin-cyl. petrol air-cooled Douglas, with fuel and oil tanks, governor, mag. ign., 2½ H.P., £25.

MOTOR PUMPS. We can give immediate delivery of the famous Stuart Turner 12-volt D.C. motor pumps; 120 gals. per hour, 84/-. Same type but for A.C. mains, 136/-. Pumps only; R type twin-piston rotary for ½ H.P. motor drive, £3/5/-.



DYNAMOS, MOTORS AND MOTOR GENERATORS. We carry a large stock of serviceable machines, but can only list a few. See last month's issue. Plenty of D.C. H.P., £3 10s.

MOTORS, D.C., in almost all sizes. A.C. ½ H.P. and 1/3 H.P. split-phase, 1,425 revs.; cheap.

TRANSFORMER COMPONENTS. Stampings Control limits supply. We offer some 100-watt transformers for rewinding. Good class. Sold for re-making, 22/6. Stalloy Sheets for Transformer Stampings, 38in. x 6in., 1/3 each.

POWER TRANSFORMERS. Single phase 50 cycles 35 KVA, 35,000 watts, by Brit. Elec. Transf. Co. 220 volts to 110/110 volts, £30. 2 KVA Foster 200 volts to 4,000 volts, £8 10s. 1½ KVA Zenith 100 volts to 6,000 volts, £8. 3 KVA 400 volts S.P. 50 cycles to 600 volts, oil filled, by Metvick, £9. All as new.



CONDENSERS. Ultra Short Wave variable air condensers. 16 m.mfd. Trolitul insulation ball-bearings. Surplus to a Govt. contract and new, 5/-.

Please send stamped envelope for answer to enquiries and include postage for mail orders.

ELECTRADIX RADIOS

214, Queenstown Road, Battersea, London, S.W.8
Telephone BACcaulay 2159

All types of radio receivers serviced. A. Murphy and Pilot specialist; valves in stock; sound repairs for 13 years.—T. F. Feyrer, F.I.P.R.E., 50, Vine St., Uxbridge.

REPAIRS to radios, amplifiers, hair dressing machines, and all radio electrical apparatus; workmanship guaranteed, time taken 10-14 days.—L. E. Healey, 125-125a, Old Rd., Clacton, Essex. We can repair anything, wholesale or retail, [2408]

REWINDS to mains and output transformers, field coils and chokes; prompt delivery on priority contracts.—Metropolitan Radio Service Co., 1021, Finchley Rd., N.W.11. Speedwell 3000. [2402]

MISCELLANEOUS

PHOTO-ELECTRIC cells, 90 volts, 21/- each.—Universal Electrical Co., 221, City Rd., London, E.C.1. [2429]

TIME recorders.—Write for particulars.—Gledhill-Brook Time Recorders, Ltd., 84, Empire Works, Huddersfield. [2419]

16MM. splicers for sale, Wardour combined guillotine and scraper type, solidly constructed, an instrument to be proud of; £5.

16MM. super film rewinders, Wardour heavy duty professional type, packs into a suitcase, made to take 1,600 reels; prices on application.—Sole distributors, Mobile Cinema Services, Ltd., Surbiton, Surrey. Elmbridge 5211-23. [2451]

RUBBER stamps made up to your special requirements, and design, typical example, stamp showing name, address and profession; 9/6 post free.—V.E.S., Radio House, Ruislip. [1884]

SYNCHRONOUS motors, "Sangamo" 200V 250 volts ac, 50c, self-starting, fitted reduction gears and extra gears, ideal movements for time switches, electric clocks, etc.; 22/6 the set.

MERCURY break trip switches, 15-20 amps. enclosed bakelite on metal saddles 2 1/10 x 7/10, terminal block, etc.; 6/6 each.

CINE lenses, 1-inch focus, combined taking and projecting, 3.5 and 1.9, fitted iris diaphragm, ideal for soundheads; 8/6 each; terms cash with order.—H. Franks, Scientific Stores, 58, New Oxford St., W.C.1. Tel. Museum 9594.

CALLERS only.—Large selection of differential reduction gears, meters, relays, etc.

NIFE nickel cadmium alkaline batteries.—Capacity alkaline cells, 70 ah to 300 ah quantity, types L, 8 and T, suitable for lighting plants, traction, starter batteries, etc.; also 1,500 yards multi circuit cable, consisting of 14 separate rubber insulated t.c. conductors, each 1/036in, whole compounded, t.r. insulated and braided; write for list; trade supplied.—Mathew Bros., 25, Sandy Lane North, Warrington, Tel. 4050. [2319]

SITUATIONS VACANT

RADIO sales assistant, Central London short wave shop.—Send details, age, experience, salary reqd., Berry's (Musical), Ltd., 10, London Rd., Camberley. [2405]

A LONDON company, scheduled, manufacturing miniature valve amplifier equipment, requires young works manager with mechanical ability, knowledge tool design, L.F. amplification, small scale production and managerial experience; the position offers excellent post-war prospects for first-class man.—Write age, experience, salary required, Box 3044.

LABORATORY assistants required by West London firm scheduled under the E.W.O., manufacturing electro-acoustic apparatus. Applicants of school-leaving age considered, but must have basic technical education, preferably including radio-telephony; successful applicants will receive specialised training; excellent post-war prospects.—State age, education, qualifications and experience, if any, to Box 3045. [2411]

LARGE electrical manufacturing concern will have vacancies in their post-war organisation for experienced buyers, and invite candidates under 35 years of age who are now in H.M. Forces or who feel uncertain about post-war prospects in their present occupation, to register their names, giving full particulars of career and capabilities; consideration might be given to immediate appointments of eligible applicants.—Box 378, L.P.E., 110, St. Martin's Lane, W.C.2. [2424]

SITUATIONS WANTED

RADIO engineer requires employment all day Saturday.—Molen, 45, Fitzjohn Ave., Hampstead. [2420]

K EEN radio engineer, age 30, electrical diploma, laboratory and production experience, requires responsible position on post-war work; free from military service.—Box 3064.

L ECTURER in Telecommunications, B.Sc. (1st Class), under 30, alien, experience of consulting work, design of radio instruments and components, contributions to technical and patent literature, seeks return to research or development.—Box 3052. [2442]

RADIO communication engineer, 30, at present lecturing, desires change, preferably to industrial employment—Box 3056

TECHNICAL TRAINING

A.M.I.E.E., City and Guilds, etc., on "No pass—no fee" terms; over 95% successes. For full details of modern courses in all branches of electrical technology send for our 112-page handbook, free and post free B.I.E.T. (Dept 388A), 17, Stratford Place, London, W.1 [2452]

GREAT possibilities exist for technically qualified engineers, key men in industry and afterwards. Through the home-study courses of The T.I.G.B. take a recognised engineering qualification, such as A.M.I.Mech.E., A.M.I.E.E., A.F.R.Ac.S., A.M.I.Chem.E., C. and G., etc., in which examinations the T.I.G.B. students have passed 25 FIRST PLACES and hundreds of passes. Write today for "The Engineer's Guide to Success" free—containing the world's widest choice of engineering courses covering all branches, including aeronautical, mechanical, electrical, wireless, chemical, etc.

THE TECHNOLOGICAL INSTITUTE OF GREAT BRITAIN, 82, Temple Bar House, London, E.C.4. [1405]

TUITION

LEARN Morse code the Candler way.—See advertisement on page 28. [1292]
RADIO training.—P.M.G. exams, and I.E.E. Diploma; prospectus free.—Technical College, Hull [10611]

ENGINEERING Opportunities.—Free 112-page guide to training for A.M.I. Mech.E., A.M.I.E.E., and all branches of engineering and building; full of advice for expert or novice; write for free copy, make your peacetime future secure. B.I.E.T. (Dept 387B), 17, Stratford Place, London, W.1.

A POSTAL training in electrical engineering—power or radio; individual correspondence tuition by highly qualified engineers with wide teaching and technical experience—Elementary or advanced courses. Preparation for recognised examinations. Pre-service training specially arranged.—G. B., 18, Springfield Mount, Kingsbury, N.W.9. [1731]

● **NEW VALVES** ●
TUNGSRAM, ETC.

SP220, equivalent to P2, P20A, PM202, PM2, etc., 6 -
DDT18, equivalent to TD113, CE3B, 11D, etc., 9 6.
DDT18S, equivalent to TD113, etc., 9 6.
Equivalent to VP20, HP2118, etc., 12 6.
Philco 1A4 and 1B4, 9 - each.

Assortment of Components, specially suitable for Radio students, constructors, etc., containing all kinds of useful gear, service sheets and journals, £1 per parcel.

Post and packing extra. Complete satisfaction guaranteed. Terms—Cash with order. Mail order only. No callers, please.

E. H. ROBINS TRADING CO., LTD.
44, Kyle Crescent South, WHITCHURCH, Glam.

"SYSTEMATIC RADIO SERVICING"

A method for organising the repair-shop, devised and employed by J. Bull. Also a catalogue of many Radio Service Aids including "History of Faults," "Job Cards," which almost repair the sets, "Valve Base Data Cards," and perhaps most important, a Rectifier which will replace any of the popular universal valves such as 12Z3, 25Z5, 1D5, U30, 40SU4, etc. Price 1/7 p.f.

V.E.S.

(W) Radio House, Methorne Drive, Ruislip, Mdx.



Illustration shows standard 240 watt model. Other types and sizes for various specialised jobs.



W. T. HENLEY'S TELEGRAPH WORKS CO. LTD.
Engineering Dept., Milton Court, Westcott, Dorking, Surrey

There's no corrosion of the connections in the Solon Electric Soldering Iron. Tucked neatly away at the end of the handle, the heat can't get at them. Efficient rubber sleeve cord grip prevents sharp bending of the flexible. The heating element is inside the copper bit—giving constant heat; no waste of current! Features that make Solon soldering quicker, cleaner, safer. All Solon irons are supplied with 6ft. of Henley 3-core flexible. Made for the following standard voltages—100/110, 200/220, 230/250. Supplies are, of course, only available for essential war work. Early orders are advisable, as demands are heavy.

Made in England

MATRICULATION
Brings Success & Security

Whatever your age, you can now study for the all-important Matriculation Examination at home on "NO PASS—NO FEE" terms. "MATRIC" is the accepted passport to all careers, and opens up opportunities which would otherwise be completely closed to you. Ensure the success and security of you and yours through post-war difficulties by writing for our valuable "Guide to Matriculation" immediately—FREE.

B.T.I. (Dept. 114)

356, Oxford Street, London, W.1.

COACHING for P.M.G. examinations; 150 typical 1st and 2nd class technical questions, price by post 5/-. The North Eastern School of Wireless, 69, Osborne Rd., Newcastle-upon-Tyne, 2. [2081]

RADIO Engineering.—Television and Wireless Telegraphy, comprehensive postal courses of instruction. Apply British School of Telegraphy, Ltd., 179, Clapham Rd., London, S.W.9 (Estd. 1906). Also instruction at school in wireless for H.M. Merchant Navy and R.A.F. [9249]

THE Tuitionary Board of the Institute of Practical Radio Engineers have available home study courses covering elementary, theoretical, mathematical, practical, and laboratory tuition in radio and television engineering; the text is suitable coaching matter for I.P.R.E. Service-entry and progressive exams; tuitionary fees—at pre-war rates—are moderate.—The Syllabus of Instructional Text may be obtained post free from the Secretary, Bush House, Walton Avenue, Henley-on-Thames, Oxon. [1462]

PATENT NOTICES

THE proprietors of British Patent No. 513650, entitled "Improvements in closures for evacuated envelopes" offer same for license or otherwise to ensure it practical working in Great Britain.—Inquiries to Singer, Ehrlert, Stern and Carlberg, Chrysler Building, New York City 17, N.Y., U.S.A. [2327]

RADIO electric patents.—Well-known London radio component manufacturers are open to consider patents or designs for post war period. Write Progress, c/o Alfred Bates and Son, Ltd., 150, Fleet St., London, E.C.4.

THE proprietors of British Patents Nos. 516110, 516111, 516167, 516168, entitled Improvements in Electron Discharge Tubes, and No. 516169, entitled Improvements in bases or Caps for Electron Discharge Tubes, offer same for license or otherwise to ensure their practical working in Great Britain.—Inquiries to Singer, Ehrlert, Stern and Carlberg, Chrysler Bldg., New York City, 17, N.Y., U.S.A. [2498]

THE proprietor of British Patents Nos. 527353 and 527484 entitled "Improvements in photoelectric cells, and methods and means for making, sensitising, and stabilising the same" and "Improvements in photoelectric cells, and method for making, sensitising and stabilising the same," respectively, offers same for license or otherwise to ensure practical working in Great Britain.—Inquiries to Singer, Ehrlert, Stern and Carlberg, Steger Building, Chicago 4, Illinois, U.S.A. [2331]

BOOKS, INSTRUCTIONS, ETC.

WT.D., servicing sheets, good cond.—Haywood, 267, Sewall Highway, Coventry.

WANTED, Radio Craft, October, 1937, and March, 1938.—Best, 96, Hermon Hill, Snaresbrook, London, E.18. [2430]

SALE, "W.W.", Oct. 1936 to Dec. 1942. 6 weekly copies missing. What offers?—Warner, 9, Broomhill Rd., Ipswich. [2439]

WEBB'S radio map of the world locates any station heard, size 40x30in, 4/6, post 6d., on linen, 10/6, post free.—Webb's Radio, 14, Soho St., London, W.1. Tel. Gerard 2089. [1947]

BATTERY CHARGERS & TRICKLE CHARGERS



Trouble-free Chargers fitted with selenium all-metal rectification. A few Agencies available. Thirty years experience behind every Runbaken product. Booklet R.15, giving useful information and describing 12 Models on request.

RUNBAKEN-MANCHESTER 1

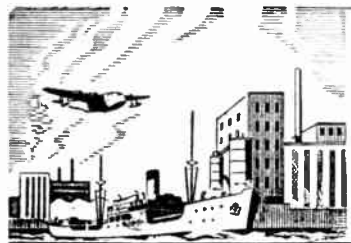

INVENTORS

We invite new inventions which, guided by the technical knowledge, manufacturing facilities and world-wide marketing organisation of the Simmonds Group, may be developed to play vital parts in modern industry.

ALL COMMUNICATIONS MUST BE IN WRITING IN FIRST INSTANCE TO—

The
SIMMONDS GROUP
LONDON
MELBOURNE
PARIS - NEW YORK
LOS ANGELES

SIMMONDS DEVELOPMENT CORPORATION LTD. 2-3 NORFOLK ST. W.C.2

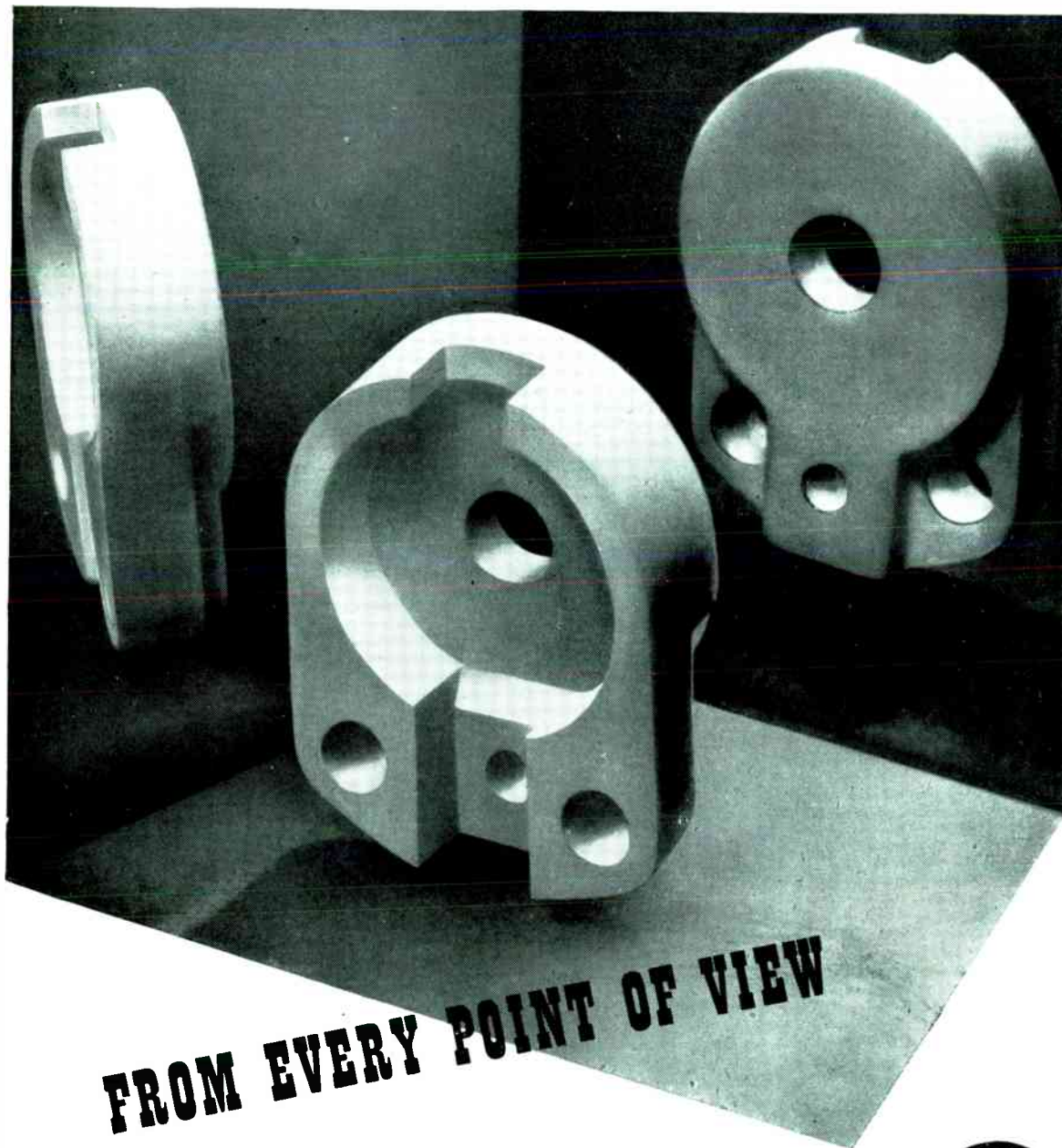

FROM EVERY POINT OF VIEW

Frequentite is the most suitable insulating material for all high frequency applications. Ten years ago we introduced the first British-made low-loss ceramic, and consultation with us before finalising the design of new components is a wise precaution.



STEATITE & PORCELAIN PRODUCTS LTD.

Head Office: Stourport-on-Severn, Worcester.

Telephone: Stourport 111.

Telegrams: Steatint, Stourport

S.P.31



Over
to you-OVER!

Intensive research and experiment by scientists and technical experts in collaboration with the service departments have resulted in important developments in design and technique. To-day the output of Osram Valves is devoted to the war effort. But Osram Valves for maintenance of existing equipments are available. Consult your usual supplier.

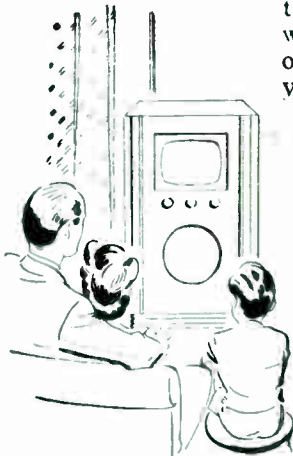

One day — perhaps soon — the progress and developments that have been made will be of the greatest interest and benefit to all. Then it will be, over to you — over!

Osram
Valves

MADE IN ENGLAND

Advt. of The General Electric Co. Ltd., Magnet House, Kingsway, London. W.C.2