

EDITORIAL COMMENT

GUARANTEES AND GOODWILL

Some time ago there was a newspaper story about a disgruntled owner of a television receiver. After suffering from a series of breakdowns and failures to get satisfactory repairs, he took the set back to the dealer's shop and hurled it through the plate-glass window. Happily, the state of affairs revealed in the subsequent court proceedings hardly reflects the typical public attitude towards radio dealers, or, for that matter, towards broadcast receiver manufacturers. All the same, it goes to show there is not so much goodwill as we would all like to see.

Part of this lack of goodwill must be attributed to the unsatisfactory nature of the guarantees given by makers of broadcast receivers. As our contributor "Diallist" points out, these are far too complicated and in some respects appear to the purchaser to be ungenerous, to say the least, particularly in regard to valves and c.r. tubes. It will be interesting to watch the effect on the public of the recent announcement by the makers of Ambassador and Baird television sets, who are now giving an extra year's guarantee with the c.r.ts.

During last autumn there was a somewhat bitter correspondence in *The Times* on the onerous nature of guarantees. Though some of the letters were directed against makers of "consumer durables" in general, the radio industry got rather more than its share of reproach.

It may be argued that there is virtually no difference between the terms of the guarantees commonly given with broadcast sets and with other comparable articles. That may be true enough, but would *Wireless World* be excessively starry-eyed in thinking the time may well have come for the radio industry to lead the rest in trying to establish a brand-new kind of relationship between seller and buyer? The old legal maxim "let the buyer beware" seems to be utterly outmoded in a world where the complex products of modern technology go into the homes of buyers whose lack of knowledge leaves them completely in the hands of the sellers.

RADIO MILESTONES

Heinrich Hertz was born exactly one hundred years ago. Oversimplifying a little, it is often said that Marconi, by connecting an effective aerial to Hertz's oscillator, made the first significant step towards a workable radio system. It is true enough to say, in the same vein, that the second fundamental advance was made in 1906 when de Forest put a grid into Fleming's diode.

During the past year Dr. Lee de Forest has received many well-deserved honours to mark the jubilee of his invention. But the triode made virtually no impact on radio technique for at least six years. It was not until regeneration was introduced in 1912 that the triode offered outstanding advantages over existing devices. The regenerative receiver, with a sensitivity vastly greater than anything known before, opened up a new world, and also paved the way for the oscillating valve generator.

According to Armstrong, who opposed de Forest during prolonged patent litigation in America, the oscillating triode was the greatest of all radio inventions.

FEBRUARY
1957

Vol. 63 No. 2

High-Power Transistor Audio

DEMONSTRATIONS of audio amplifiers built round a new range of transistors were given recently by the General Electric Company. The demonstrations were preceded by some discussion of the preferred basic design features of the amplifiers.

Suitable collector bias conditions are chosen from the current/voltage characteristics and it is then thought best to measure the small signal a.c. relationships at these conditions in order to derive equivalent circuit parameters. By this method the internal feedback, which in transistors can be significant at all frequencies, can be more easily taken account of. This procedure is not as complicated as it may seem, for several of the equivalent circuit parameters are found to be roughly the same in many circumstances.

Advantages of Class B Operation.—As regards the choice between class A or class B operation, there are stronger reasons for preferring class B with transistors than with valves. In transistors the collector dissipation, and the way in which this varies with the input signal, are both considerably different for the two types of operation. Thus if we take the maximum power limit as that determined by the maximum allowable mean collector dissipation, we find that the maximum available power for two transistors operating in class B push-pull is five times that for the same pair in class A; and is, in fact, five times the allowable collector dissipation. If we take the power limit as being that at which the distortion starts to increase rapidly (caused by alteration of current gain with peak current) similar ratios and powers are also obtained.

Another important consideration is the input power required. Owing to the characteristics of transistors they can be operated to much lower voltages relative to the h.t. supply than the corresponding pentode valves so that the maximum theoretical efficiencies for class A and class B operation of $\frac{1}{2}$ and $\frac{\pi}{4}$ respectively can be very nearly achieved using transistors. Under quiescent conditions the power drain with class B operation of transistors is of the order of 0.1 of the maximum output power rising to 1.3 times the maximum power when this is being delivered. With class A operation there is a continual drain of about four times the maximum power.

Having regard to these two factors of available power and power input required, the best use of a.f. transistors will be made in class B battery amplifiers, i.e., in public address or in ordinary commercial battery receivers. Other factors supporting this view are their compactness and the low voltage supplies required. Furthermore, when a push-pull class B transistor amplifier is overloaded the "clipping" distortion produces little loss of clarity for public address purposes.

The common emitter type is preferred for both small and large signal amplifiers. This has the highest gain and any disadvantages can be conveniently avoided in circuits which reduce this gain. For example, the input resistance of such amplifiers is often undesirably low (e.g., when using a crystal pickup); and in order to increase this the simple

addition of a series resistor is most convenient in spite of the loss of gain.

Phase Splitting Circuits.—In most of the amplifiers mentioned a transformer phase splitter was adopted. This gives a higher gain than if a transistor is used, but the size of the transformer may sometimes be a disadvantage. As the impedances concerned are low the transformer specification will be somewhat different from that in a valve amplifier. Thus the minimum primary inductance required for good l.f. response will be much less, being of the order of 50 millihenrys rather than 50 henrys. On the other hand the d.c. resistance must be very low necessitating thicker wire.

If a transistor is used to provide phase splitting the coupling condensers tend to charge up, and the forward bias on the output transistors necessary to reduce crossover distortion is decreased. The maximum available power is then decreased, though the frequency response is improved.

In such transformer phase splitting circuits with transistors, several new types of distortion arise; but apart from the normal panacea of negative feedback other techniques are available for considerably reducing these. Thus the changing input resistance as one transistor takes over amplification from the other every half cycle (the emitter resistance varies inversely with the emitter current) can be avoided by a small amount of forward bias (≈ 100 mV) to the emitter-base junction so that a positive emitter current flows under quiescent conditions. Carrier storage effects producing ringing at a high frequency, which occur as well when the signal changes sign, can also be largely eliminated by bifilar winding of the secondary of the phase splitting transformer.

Phase changes in the transformers as well as in the transistors themselves of course limit the amount of feedback that can be supplied; but there is no difficulty in obtaining the roughly 7 dB overall feedback required to reduce distortion sufficiently in class B amplifiers, if an RC feedback loop is used to take some account of these phase shifts. The application of feedback in transistor circuits is also important for reducing the effect of variation among individual transistor characteristics in mass production or replacement.

Complete Amplifiers.—Seven different amplifiers have been made with maximum powers ranging from 250 milliwatts to 20 watts. They consist of an input amplifying stage, the phase splitting transformer, and a push-pull output stage. For the class B amplifiers the total harmonic distortion at maximum power was $\approx 8\%$. The 4-watt class A amplifier which was demonstrated (corresponding to the 20-watt class B amplifier using the same transistors) had 0.8% total harmonic distortion at 4 watts (0.5% at $2\frac{1}{2}$ watts) with 16 dB overall feedback. This distortion could have been reduced to 0.3% at 4 watts by using a class A push-pull driver stage. Power gains for both types of amplifier were ≈ 50 dB or greater.

The 250 mW amplifier corresponds to the usual battery radio valve output stage. However, in normal

use the volume control is often set so as to cause overloading; so that an improvement in quality can be effected using a 1-watt amplifier, though a disadvantage is that the quiescent current drain is nearly doubled. There is no corresponding battery valve equivalent in this case.

A very compact battery-operated, 45 r.p.m., record player using the 1-watt amplifier was demonstrated. The battery life when supplying the turntable as well as the amplifier is about 15 hours using 5 U2 batteries. Although this may not seem very much; as the G.E.C. representative remarked, "15 hours worth of records take a very long time to play!"

The 250-mW amplifier for the output of a transistor a.m. receiver which was also shown in a very compact form, used a directly coupled 120-ohm centre-tapped loudspeaker voice coil. This increases the thermal stability in the output stage because of the d.c. resistance, but the application of overall feedback in two balanced loops is difficult. A single-ended push-pull output stage was described as a means of rapidly changing to twice the power supply voltage for a normal push-pull output stage; but there was no direct coupled loudspeaker application for this case.

As regards other applications of these transistors, low-noise pre-amplifiers developed include the usual bass and treble tone controls; and for a normal microphone (600-ohm output impedance) or pickup ("variable reluctance" or crystal) input signal, give signal to noise ratios of about 60 dB. Concerning the possibility of a transistorized tape deck the most difficult problem is the provision of erase power. Two EW70s (one of the new types of transistor) can be used in class B push-pull to deliver 2 watts at 35 kc/s, thus largely solving this problem.

Details of New Range.—The new G.E.C. tran-

sistors are all of the germanium junction *p-n-p* type. They are hermetically sealed and of all-metal construction; the metal can provides a heat sink, and facilitates the attachment of a radiator. The low-resistance base connection, which is also integral to the construction, besides providing good thermal contact, also enables the potential h.f. performance to be more fully realized.

Having regard to their general characteristics and maximum allowable collector dissipation there are essentially three new transistor types. These are known as the GET 4 and 6, GET 5 (formerly EW70) and the EW57 (provisional); and have allowable collector dissipations (at 45°C) of 50 mW, 400 mW and 4 watts respectively. The frequency cut-offs are ≈ 250 Kc/s for the EW57 and greater than 1 Mc/s for the others.

The GET 6 is a low-noise version of the GET 4 and has a noise level well comparable with that in thermionic valves. The EW57 is also subdivided into three types according to the supply voltage required (6, 12 or 24 volts). All of these transistors have been in pilot production for about two years and should be in quantity production later this year.

With regard to the limiting operating conditions for these transistors there was thought to be good prospects of improvement. At present the maximum operating temperature is 50°C, but this can probably be increased up to about 70°C. If collector leakage currents become embarrassing silicon transistors (samples of which should be available before the end of the year) would be a complete answer and should function to well over 100°C.

The power limit should also see a major improvement with operation at high collector temperatures. Moreover experimental samples which maintain their current gains at high values of emitter current (another limiting factor) have also been produced.

COMMERCIAL LITERATURE

Printed Circuits.—An illustrated booklet for engineers and technicians on the available types of printed circuits and the problems of designing equipment using them. Rigid, flexible and flush-bonded types are discussed, also incorporated components, heating elements, and facilities offered for development and production. From Technograph Printed Circuits, 32, Shaftesbury Avenue, London, W.1.

Tape-to-Disc Transfer Service.—Details and prices in a leaflet from Sound News Productions, 59, Bryanston Street, Marble Arch, London, W.1.

Sound Reproduction Equipment ("New Orthophonic High Fidelity"), including amplifiers, loudspeakers, tuner, transcription unit and pickups. Price list from R.C.A. Great Britain, Lincoln Way, Windmill Road, Sunbury-on-Thames, Middlesex.

High-Conductivity Copper Alloys, containing silver, cadmium, chromium, and tellurium. The last three decrease the conductivity slightly but give other desirable properties such as increased strength, resistance to wear and machinability. An informative booklet of 54 pages, containing many tables of properties, from the Copper Development Association, 55, South Audley Street, London, W.1.

High-Quality Loudspeaker in Helmholtz resonator enclosure measuring 22in \times 12in \times 13in. Power handling in excess of 6 W for low distortion, and level frequency

response over 40-10,000 c/s. Leaflet from RGA Sound Services (Plymouth), 6, Conway Gardens, Enfield, Middlesex.

Radio and Electronics Books including the Philips series on valves, etc., listed in a catalogue from the Cleaver-Hume Press, 31, Wright's Lane, Kensington, London, W.8.

Small Capacitors suitable for loudspeaker crossover networks, claimed to occupy only 25-30% of space required by conventional types. Capacitances between 2 and 16 μ F, working voltage 150 V d.c. Leaflet from A. H. Hunt (Capacitors), Wandsworth Road, London, S.W.18.

Variable Output Transformers (Regavolt) with self-aligning brushes to ensure maximum surface contact with winding. Four new types for normal mains voltages, with outputs variable over 0-275 V, currents between 6 and 10 A, and one new type for 115-V mains and output of 0-135 V at 15 A. Leaflets from the British Electric Resistance Company, Queensway, Enfield, Middlesex.

Microphones; crystal, ribbon, carbon and noise-cancelling types; also stands, table bases, transformers and other accessories. Illustrated catalogue from Lustraphone, St. George's Works, Regents Park Road, London, N.W.1.

Strain-Gauge Bridge, giving direct reading in percentage strain over the range 0.001% to 0.5%. Accuracy of measurement, $\pm 1\%$. Leaflet from the Croydon Precision Instrument Company, Hampton Road, West Croydon, Surrey.

WORLD OF WIRELESS

Organizational, Personal and Industrial Notes and News

I.S.M. Interference

RADIO interference from industrial, scientific and medical equipment is being considered by a committee set up by the Postmaster-General to advise him on the making of regulations prescribing limits of radiation.

The Wireless Telegraphy Act prescribes that the members of such advisory committees should either "possess expert knowledge of the matters falling to be dealt with" or "represent persons whose interests are likely to be affected" by any regulations made. The nineteen-man committee, of which O. W. Humphreys is chairman, therefore covers the interests of those concerned with both the cause and effect and includes representatives of the B.B.C., I.T.A., equipment manufacturers, air navigational specialists, production engineers, the medical profession and the viewer and listener.

V.H.F. Coverage

BY the opening of three more v.h.f. broadcasting stations (Wenvoe, replacing the temporary low-power transmitter, Sutton Coldfield and Norwich) a day or two before Christmas, the B.B.C. made good its promise to complete the first batch of ten stations by the end of 1956. To say "complete" is perhaps a slight exaggeration, for the Cardigan-shire station at Blaen Plwy at present has only one of its three transmitters (Home Service) working. An eleventh station, at Penmon, was subsequently added to the original chain, but so far only one transmitter has been installed and this is radiating the Home Service with an e.r.p. of 1kW.

The service now reaches 84% of the population.

	Light (Mc/s)	Third (Mc/s)	Home (Mc/s)	e.r.p. (kW)
N. Hessay Tor (S. Devon) ...	88.1	90.3	92.5	60
Sutton Coldfield (Warwicks.)	88.3	90.5	92.7	120
Pontop Pike (Co. Durham) ...	88.5	90.7	92.9	60
Meldrum (Alderdeenshire) ...	88.7	90.9	93.1	60
Blaen Plwy (Cardigan) ...	88.7	90.9	93.1	60
Wrotham (Kent) ...	89.1	91.3	93.5	120
Holme Moss (Yorks.) ...	89.3	91.5	93.7	120
Penmon (Anglesey) ...	89.6	91.8	94.0	60
Norwich ...	89.7	91.9	94.1	120
Wenvoe (Glam.) ...	89.9	92.1	94.3	120
Divis (N. Ireland) ...	90.1	92.3	94.5	60

U.K. Display in New York

THE Institute of Radio Engineers' annual convention and show, which last year attracted 714 exhibitors, is being held in New York from March 18th to 21st. The Institute has offered an area of 1,200 sq ft for a collective U.K. display of radio and electronic equipment. Manufacturers interested in participating should communicate at once with the Board of Trade, Exhibitions and Fairs Branch, Lacon House, Theobalds Road, London, W.C.1. (Tel.: Chancery 4411, Extn. 436.)

Tape Recording Patents

THE Armour Research Foundation has carried out extensive research during the past 15 years on all aspects of magnetic recording, and has filed over one hundred American patents; most of these have also been granted in the United Kingdom.

John P. Skinner, manager of the A.R.F. Development Corporation, a subsidiary of the non-profit-making Foundation, stated during a recent visit to this country that to make an effective tape deck it is necessary to use principles contained in at least one of the A.R.F. patents.

It is understood on enquiry that licensing agreements have already been concluded by the A.R.F. Development Corporation, of Chicago, Illinois, with the following companies in this country: Boosey and Hawkes, Collaro, Garrard, E.M.I., Grundig, Simon, Tape Recorders (Electronics), Verdik Sales, Walter (Tape Recorders), and Wright and Weaire.

Amateurs and TV Interference

A NEW policy regarding amateur interference with sound and television reception has been announced by the Post Office. In the past, if complaints were received of an amateur causing interference to television reception due to "blocking," the Post Office prescribed that he must not transmit during television broadcasting hours.

Under the new arrangement if an amateur is otherwise transmitting within the terms of his licence, but causes interference to sound or television reception and it can be demonstrated that a reasonable remedy, such as the fitting of a simple filter, is available to the owner of the receiver, "then the amateur will be allowed to continue operating after an interval of one month from the time at which the cure is explained and demonstrated to the complainant by the Post Office."

It is understood that this will apply to all cases of interference to sound and television reception where the amateur's transmissions are found to be within the terms of his licence.

Although B.R.E.M.A. has been informed of the new policy no official announcement has so far been made on behalf of receiver manufacturers.

NEW YEAR HONOURS

A number of those who played a leading part in the planning, production and laying of the Atlantic telephone cable were recipients of awards in the New Year's Honours List. They include **J. N. Dean**, chairman of the Telegraph Construction and Maintenance Company (Knighthood); **R. J. Halsey**, an assistant engineer-in-chief at the G.P.O. (C.M.G.); **A. H. Roche**, telecommunication engineer in charge of Submarine Cable System Development and Production Division, Standard Telephones & Cables (O.B.E.); **E. F. Neve**, foreman S.T.C. submerged repeater manufacturing shop (B.E.M.); and **E. V. T. Perrins**, technical officer Post

Office Research Station, who has specialized in repeater test equipment (B.E.M.).

Sir Stanley Angwin, who recently retired from the chairmanship of the Commonwealth Telecommunication Board, and **E. M. Jones**, director, the Government Communications Headquarters, Foreign Office, are appointed K.C.M.G.

Three members of the G.E.C. Research Laboratories staff received awards:—**O. W. Humphreys**, director, is appointed C.B.E.; **E. G. James**, head of crystal valve development, O.B.E.; and **W. C. Cropper**, group leader in charge of a special project for the Admiralty, M.B.E.

Among those appointed M.B.E. are **Miss B. K. Chaplin**, executive officer at the D.S.I.R. Radio Research Station; **W. H. Hopkins**, works manager, E.M.I. Factories; **G. W. Kilmster**, first radio officer, R.M.S. *Arundel Castle*; **E. L. Lycett**, assistant, B.B.C. outside broadcasts; **H. Starr**, signals officer, Civil Aviation Telecommunication Directorate, Ministry of Transport and Civil Aviation; and **W. W. Syrett**, export manager of Ekco's Radio Division.

Among overseas radio personalities who received honours are **L. A. G. Hooke**, managing director of Amalgamated Wireless (Australasia), a knighthood for "services to the radio industry in Australia"; **T. W. Chalmers**, formerly director of broadcasting in Nigeria, C.B.E.; **T. V. Hooley**, officer-in-charge, Government Wireless Station, Falkland Islands, M.B.E.; and **E. R. Richardson**, senior assistant controller of telecommunications, Nigeria, M.B.E.

PERSONALITIES

Sir Noel Ashbridge, who retired from the directorship of technical services of the B.B.C. in 1952 and became a director of Marconi's, has been elected an honorary member of the Institution of Electrical Engineers. The election is in recognition of his services to the Institution, of which he was president in 1941, and of "his outstanding contributions in the field of radio engineering, particularly in the development of the British sound and television broadcasting services."

After what must be a record for service with one radio company—over 54 years—**R. D. Bangay** has retired from Marconi's. In 1952 he celebrated his jubilee in the radio industry, the first man to do so. Soon after joining the company in 1902 he went to America for five years and helped in the installation of the first U.S. coastal radio station, at Babylon. He was concerned with the original experiments in air-to-ground communication, and in 1914 was placed in charge of the company's department established for the development of military radio equipment. Mr. Bangay was for some years chief of designs, and since 1935 has been foreign manager. He was the author of two books published by *Wireless World* many years ago: "The Elementary Principles of Wireless Telegraphy" and "The Oscillation Valve."

L. C. Jesty, B.Sc., M.I.E.E., has left Marconi's, where for seven years he led the television research group, and has joined the Sylvania-Thorn Colour Television Laboratories at Enfield, Middlesex. He will be in charge of colour television research. Whilst at Marconi's research laboratories he had been closely concerned with the Anglicized version of the American colour system which has been used experimentally by the B.B.C. From 1927 to 1946 Mr. Jesty was on the staff of the G.E.C. Research Laboratories where in 1933 he started the c.r.t. research group which was responsible for the introduction of the VCR97. For three years prior to joining Marconi's he was in charge of advanced research at the Cinema-Television Laboratories.



Reginald A. Yeo has left the Admiralty Signal and Radar Establishment, at Haslemere, where he was head of the electronics division, on being appointed full-time member of the Australian Broadcasting Control Board. He was a principal scientific officer in the Royal Navy Scientific Service, and was concerned mainly with radio matters throughout his government service. He was delegate at the conference of the International Telecommunication Union at Atlantic City in 1947.

G. B. Jeffery, M.A., B.Sc., A.M.I.E.E., has left the Royal Aircraft Establishment, Farnborough, where for four and a half years he has been senior engineer in the data transmission section of the Electrical Engineering Department, and has joined R. B. Pullin and Co. He is technical sales manager of the Pullin-Kearfott Division, which, under a recent licensing agreement with the American Kearfott Company, Inc., will manufacture synchros, servomotors and tachometer generators. During the war Mr. Jeffery was a radar officer, R.N.V.R., and was on the staff of H.M. Radar School, H.M.S. *Collingwood*.

H. L. A. Foy, the new publicity manager of Decca Radar, Ltd., has been engaged on the operational aspects of radar since he joined the company two years ago. He was a specialist navigating officer in the Royal Navy, and since joining Decca has been particularly concerned with the introduction of "True Motion" radar.

C. Hardy and **C. B. Speedy**, Ph.D., B.E., Grad.I.E.E., have been appointed directors of Data Recording Instrument Company, Ltd., of Feltham, Middlesex, which previously operated as a division of Lion Electronic Developments, Ltd. Mr. Hardy was for many years at the Signals Research and Development Establishment of the Ministry of Supply, where he was working on data recording. Dr. Speedy has been engaged since 1945 on the study of electronics especially in relation to computers.

J. N. Macleod and **C. Metcalfe** have been appointed directors of Electric and Musical Industries, Ltd. Together with **E. J. Emery**, who was appointed a director last February, they have been appointed managing directors of the company, responsible, respectively, for the U.K. Record Division and the Oversea subsidiary companies (other than Capitol Records Inc. and its subsidiaries), the E.M.I. Electronics Division (commercial and industrial equipment), and the Domestic Electronics Division.

H. A. Lewis, M.B.E., T.D., B.Sc.(Eng.), A.C.G.I., M.I.E.E., who recently left Marconi's to become personal assistant to E. J. Emery, managing director of the Domestic Electronics Division of E.M.I., has been appointed a director of E.M.I. Sales and Service, Ltd.

D. L. Johnston, who in our October, 1954, issue described a transistor replacement unit for hearing-aid h.t. batteries, has left Fortiphone, Ltd., where he was manager of the component division, and has joined Automation Consultants and Associates, Ltd.

The following appointments are announced by Belling and Lee: **D. W. Ripplin**, who has been outside technical representative, becomes export manager; **J. E. Bailey**, B.Sc., and **R. E. Meldrum** join the company as technical representatives to manufacturers, and **A. Fender** is appointed technical sales representative to the trade in the area centred on Newcastle-upon-Tyne.

L. C. Smith has resigned from Plessey's which he joined ten years ago as technical representative. During the last war he was lieutenant-commander in the electrical branch of the Royal Navy and specialized in the maintenance of asdic. Before the war he ran his own service business in Birmingham for five years, prior to which he was a service technician with E.M.I. His address is 122, Whitaker Road, Derby.

Peter E. M. Sharp, A.C.G.I., B.Sc.(Eng.), A.M.I.E.E., whose three-year contract with China Engineers, Ltd., has ended, has returned to this country. He joined the Telegraph Construction and Maintenance Company in 1951, subsequently transferring to their agents in the Far East. His home address is 46, Hyde Vale, London, S.E.10.

OUR AUTHORS

Dr. E. L. C. White, of the research division of E.M.I. Electronics, who recently addressed members of the Television Society on alternatives to the American television system, contributes an article on page 75 covering some of the points discussed. Dr. White has been with E.M.I. since 1933 and was closely associated with the late A. D. Blumlein in developing the Marconi-E.M.I. television system adopted by the B.B.C. During, and to some extent since, the war, he has been concerned with the development of radar display systems, but has more recently worked on colour television. Before joining E.M.I. he was for three years at Cavendish Laboratory, Cambridge, working on pulse methods of ionospheric research. He is 47.

Michael P. Beddoes, contributor of the article on an improved sync separator, went to Canada a few months ago, and is now assistant professor in electrical engineering at the University of British Columbia. After graduating in electrical engineering at Glasgow University he spent seven years in industry, and then in 1953 went to the City and Guilds College where he worked on television band-compressing systems. His industrial experience started at G.E.C., Coventry (as a post-graduate apprentice), and after service as a senior engineer at Plessey's he became assistant chief engineer of McMichael's radio division.

IN BRIEF

During November the number of television licences increased by 142,345 bringing the total to 6,433,417. **Broadcast receiving licences**, including those for television and 310,690 for car radio, totalled 14,424,236 at the end of November.

Brit.I.R.E. Constitution.—An extraordinary general meeting of members of the British Institution of Radio Engineers is being held on January 30th, at which it is proposed to redraft the constitution. It is understood that the whole of the articles of association are being revised to give emphasis to the Institution's coverage of electronics.

"Wireless World" Index.—The publication of the Index for 1956 has been unavoidably delayed; it will be available towards the end of February. Cloth binding cases with index cost 7s 6d (postage 6d). Our Publishers will undertake the binding of readers' own issues, the cost per volume, including the index and binding case, being 22s 6d, plus 1s 6d postage on the bound volume.

Bilingual Television.—The system for transmitting two sound programmes in a single sound channel described on p. 79 has actually been developed for use by the French television service in Algeria, which has both French and Arabic viewers. A complete description, with a photograph of the "decoder" unit, appears in the January issue of the French journal *Television*.

American TV in Germany.—Television on American standards is being radiated from two transmitters in Germany for the benefit of U.S. service men. The low-power stations, which operate in Band IV (470-585 Mc/s), are at Bitburg and Landstuhl. They transmit films, provided by the Armed Forces Television centre at Limestone, Maine, for seven hours a day.

The **French Components Show** will be held from March 29th to April 2nd at the Parc des Expositions, Porte de Versailles, Paris.

America's Institute of High-Fidelity Manufacturers is sponsoring a **Hi-Fi Show** in Los Angeles from February 6th to 9th.

An electronic **computing service** for industrialists and scientists has been introduced by the Battelle Institute at Frankfurt/Main, Germany. Enquiries regarding the service and the facilities provided are being handled in this country by the Electronics Division of Remington Rand, Ltd., Commonwealth House, 1-19, New Oxford Street, London, W.C.1.

Interference Suppression.—Another conference on radio interference (the third) is being organized by the Armour Research Foundation of Illinois Institute of Technology. It will be held in Chicago on February 26th and 27th.

Colour Television.—Sales of R.C.A. colour television receivers were expected to reach the forecast 200,000 for 1956. It is anticipated that half a million colour receivers will be produced by R.C.A. this year.

Special courses in **higher technology**, being held during the spring and summer terms at colleges in London and the home counties, are listed in a bulletin issued by the Regional Advisory Council for Higher Technological Education. It costs 1s 6d and covers a wide variety of courses, including radio and allied subjects, being held at twenty-nine colleges.

I.o.M. Television.—A permanent television station, to replace the temporary one which has been in use since December 1953, is to be built by the B.B.C. at Carnane, near Douglas, Isle of Man, by the end of this year. The original plan to build the permanent station on Snaefell has been dropped.

Peterborough is having a three-day audio fair starting on January 22nd. It is being organized by Camera and Cine Centre, of 14, Long Causeway, at the Grand Hotel where lectures and demonstrations are being given by representatives of audio equipment manufacturers.

Each Saturday from 10 to 12 noon **demonstrations** of audio equipment are being given by Pamphonic Reproducers at their showrooms at 17, Stratton Street, London, W.1.

An inexpensive (25s) single-stage **transistor audio amplifier**, intended for working with a crystal receiver is being made by Warren's Radio, 88, Wellington Street Luton, Beds.

A **bibliography** of high-fidelity sound reproduction has been compiled by K. J. Spencer; and is available from the Library Association, Chaucer House, Malet Place, London, W.C.1; price 2s 6d. Approximately three hundred references, mostly later than 1947, are given. A more extensive bibliography of the subject is being prepared.

"Portable Transistor Superhet".—The germanium diode detector in this circuit (January issue) has been drawn with the wrong polarity of connections. It should be reversed, so that a positive-going a.g.c. voltage is applied to the base of the 1st i.f. transistor.

R.S.G.B. Membership.—The annual report of the Radio Society of Great Britain records that whereas during the past five years membership had declined by nearly 5,000, last year's decrease was only 57. The number of licensed amateurs in the Society actually increased by 95, bringing the total to 5,141. Non-transmitting members total 2,961.

Winning Design in the competition sponsored by the British Plastics Federation "to encourage young craftsmen to design articles in plastics materials" was for a 17-in portable television cabinet. The designer, E. J. Arundell, of Liverpool, receives 50 guineas.

Two 16mm Mullard sound films—one on cathode-ray tubes (lasting 32 minutes) and another on quality valves (27 minutes) are now available on free loan from the Central Film Library, Central Office of Information, Government Building, Bromyard Avenue, Acton, London, W.3.

The products and services of over seven thousand member firms of the Federation of British Industries, listed alphabetically under more than 5,400 headings, as well as lists of trade marks and trade names, are included in the 1957 edition of the "F.B.I. Register of British Manufacturers." French, German and Spanish glossaries are also incorporated in the Register, which is obtainable from our publishers, price two guineas, post free.

E.I.B.A.—A number of radio manufacturers are listed as donors to the Electrical Industries Benevolent Association in its 1956 Year Book. In addition, the Radio Industry Council gave £500, the B.B.C. £158, and the Radio Industry Clubs of London and Glasgow £350 and £140, respectively. The object of the Association is to assist deserving and necessitous persons who are, or have been, in "any branch of an electrical industry."

BUSINESS NOTES

Nine film scanners, each employing two film projectors and two television cameras, have been ordered by the B.B.C. from Pye. A feature of the equipment is that by the use of movable mirrors either camera can be focussed on a projector, thus minimizing the possibility of breaks in transmission.

An underwater television camera, which can be held by a frogman or diver, towed or fitted to a vessel, has been produced by Pye. Spherical in shape, it is intended for use at depths down to 3,000 feet. It incorporates a depth indicator from which readings are conveyed to observers on the surface.

Type approval, covering humidity and temperature, has been granted by the Joint Service Radio Components Standardization Committee for Ferranti's 2-in sealed instruments—voltmeters, ammeters and milliammeters. Their 2½-in and 3½-in instruments are classified as "design approved."

Communication on six v.h.f. channels is provided in the air traffic control system recently installed by International Aeradio at Vickers-Armstrong's airfield at Wisley, Surrey.

Two limiter stages are incorporated in the new Orthophonic high-fidelity f.m. tuner being produced by RCA Great Britain. The circuit employs seven valves, two crystal diodes and a tuner indicator.

Sales abroad accounted for £33M of the E.M.I. group's £53M turnover during the year ended June, 1956. The year's total was an increase of £11.4M on the previous twelve months.

Orders for millimetre-band telecommunication test equipment valued at over £25,000 have been placed with Marconi Instruments by the Ministry of Supply. Each 6-ft rack-mounted assembly comprises electronically regulated power supply and a frequency stabilization system.

A distribution centre, including showrooms and service information department, for Ambassador and Baird receivers, has been opened at 131, Great Suffolk Street, London, S.E.1 (Tel.: Hop 0791). K. H. Yandell, sales director of Ambassador Radio and Television, Ltd., and F. Duer, southern area sales manager, are now at this address.

Shirley Laboratories, Ltd., which was formed in 1954 by A. W. Wayne (a contributor to *Wireless World*) for the manufacture of amplifiers, tuners and electronic instruments, has moved to 3, Prospect Place, Worthing, Sussex. (Tel.: Worthing 30536.)

Tape Recorders (Electronics), Ltd., have recently started production at their second factory at 784-788, High Road, Tottenham, London, N.17. The price of their Sound Cadet recorder has been reduced to 39 gns.

S.S. Electronics, Ltd., recently moved from Harrow to Chiltern Works, Severalls Avenue, Chesham, Bucks. (Tel.: Chesham 8909.)

The midland office of Marconi Instruments, Ltd., formerly situated at 19, are now at 24, The Parade, Leamington Spa.

Goodmans loudspeaker cabinet, formerly known as the Viscount and recently renamed Canberra, is now called Sherwood.

OVERSEAS TRADE

Since the formation of Decca Radar og Navigator A/S, Bergen, the Norwegian subsidiary of the Decca Radar and Navigator Companies, in February, 1955, orders have been secured for radar installations in more than 300 Norwegian ships. It has also established a chain of service depots. The company's new general manager is F. I. Willoch. He has taken over from E. Tyler who has returned to the London office.

According to a recently completed analysis of places to which Britain exports radio and electronic gear, the United States was the largest buyer of British radio equipment in the first six months of last year. The value of U.K. radio exports to the U.S.A. was £1.6M, nearly 8 per cent of the industry's total overseas trade. Incidentally, the bulk of this was for sound reproducing equipment.

Marconi's are installing a temporary 2-kW medium-wave broadcasting transmitter at Brunei, on the north-western coast of Borneo, preparatory to setting up a permanent 20-kW transmitter on Tutong, some 35 miles from the town. The permanent transmitter will be fed by a frequency-modulated radio link from Brunei. A receiving station with double reversible rhombic aerials in dual diversity for the reception of B.B.C. and Australian stations, and dipole arrays for the reception of less distant stations, is also being built.

A contract for a v.h.f. multi-channel radio-telephone system for India's Western Railways has been placed with Marconi's. The radio-telephone links, which will have a capacity of 48 two-way channels, will be between Bhavnagar and Surat, and Jamnagar and Rajkot.

Pye "Ranger" v.h.f. radio-telephone equipment, employing channel spacing of only 15 kc/s, was recently demonstrated in Toronto. This equipment is being made available immediately for those countries where there is intense frequency congestion.

Kelvin-Hughes echo sounders and radar have been fitted in the 47,000-ton tanker *Evgenia Niarchos*, the biggest yet built in this country.

Representation of U.K. manufacturers of loudspeakers, selenium rectifiers and tape recorders is being sought by John R. Tilton, Ltd., of 51, McCormack Avenue, Toronto 9, to whom illustrated literature, with ex-works and c.i.f. Canadian port prices in Canadian dollars, should be sent.

Output Transformerless Amplifiers

A GENERAL REVIEW

THOSE of us who are in search of perfection in audio amplifiers must often have looked askance at the output transformer. In general it would be possible to reduce the non-linearities in an amplifier below any desired value by the application of a sufficient amount of feedback. However, as is well known, the output transformer produces undesirable phase shifts at the extreme ends of the audio spectrum which limit the amount of feedback which can be applied before instability sets in. These phase shifts also decrease the effective feedback at these extreme frequencies and this causes increased distortion in these regions. Varying core losses, hysteresis effects, matching variations, and incomplete coupling between the primaries also more directly increase the distortion, and this increase also is more pronounced at the frequency extremes.

Modern transformer design techniques of sectionalized windings, and particularly the use of C-cores, have to a large extent overcome these disadvantages in practice; but this has naturally given rise to an increase in price, and the fundamental limitations still remain.

Increased Possibility of Class B Operation.—Using loudspeakers of normal efficiency and impedance (15-ohm) in an average living room an accepted peak power requirement from the amplifier is of the order of fifteen watts. In this case if there is no output transformer we will obviously require currents of the order of one ampere from the output valves.

The problem of obtaining these currents is somewhat eased because in transformerless amplifiers class B operation of the output valves becomes more feasible than such operation is in an amplifier with an output transformer. Normally in class B operation using an output transformer incomplete coupling between the two half primaries produces transients when the valves cut off. These transients produce distressing audible distortion and are very difficult to eradicate, though a special bifilar transformer with both cathode and anode feeds designed by McIntosh and Gow¹ does succeed in doing so.

In class B operation owing simply to the higher outputs the general distortion is higher but this is not seriously so and can, of course, be reduced by increased feedback.

High-Impedance Loudspeakers?—Allied to the difficulty of obtaining sufficient current from the output valves is that of matching, without too much distortion, the comparatively high valve impedance (of the order of a few thousand ohms) to the low impedance of the loudspeaker voice coil.

An obvious solution to both these problems is to use loudspeakers of higher impedance, but here the necessity of using thinner wire to keep the voice coil weight down produces its own problems. A few speakers of impedances in the range of 200-500 ohms

have, however, been marketed, but there is not the usual variety of models available. Readers will realize the possibility that the newer electrostatic speakers will fit more smoothly into such a system, though their capacitive nature increases the matching problem.

In general by suitably paralleling output valves a transformerless amplifier for high-impedance loudspeakers can be adapted for low-impedance ones, so that the general features of the various designs can be considered without regard to the voice-coil impedance.

Straightforward Methods.—A first approach is simply to use normal circuits with the loudspeaker directly replacing the output transformer or load,² bearing in mind that it will often be more convenient to connect the speaker in the cathode or low-voltage side of the valve.

Such designs generally involve capacitive coupling to the loudspeaker or direct current through the voice coil. Capacitive coupling requires almost impossibly high values of condenser for good low-frequency response and small phase shift in the case of low impedance loudspeakers, and may produce distortion due to hysteresis in the condenser.

Direct current in the voice coil would move it toward the positions of non-linearity for the suspension and non-uniformity of the magnetic field and in practice give a considerable increase in distortion. The possibility of increasing the linearity of the suspension (and thus decreasing the distortion), while maintaining sufficient restoring force to allow the required audio power to be developed, has already been largely exhausted in the design of conventional loudspeakers.

Distortion caused by a non-uniform magnetic field could be avoided by making the voice-coil longer than the field so that the same length is always immersed in the field. This arrangement is often used in bass loudspeakers where the increased weight of the voice-coil is less important. An equivalent method would be to lengthen the magnetic field but the larger magnets required would increase the cost. The alternative of having the voice-coil initially asymmetrical with respect to the magnetic field would require a change in the initial displacement for different amplifiers and is thus rather impracticable.³

This simple approach also unfortunately needs a centre-tapped voice coil for normal push-pull operation. For "ultra-linear" operation two more tapings are even necessary! From the point of view of requiring as little and as practical a change as possible in existing loudspeaker design this approach is seen to be inadequate.

Some sort of balanced arrangement whereby direct current in the voice coil is avoided would be an improvement. A straightforward circuit along

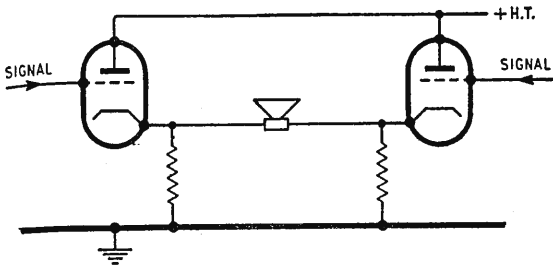

Fig. 1. Fletcher-Cooke output stage.

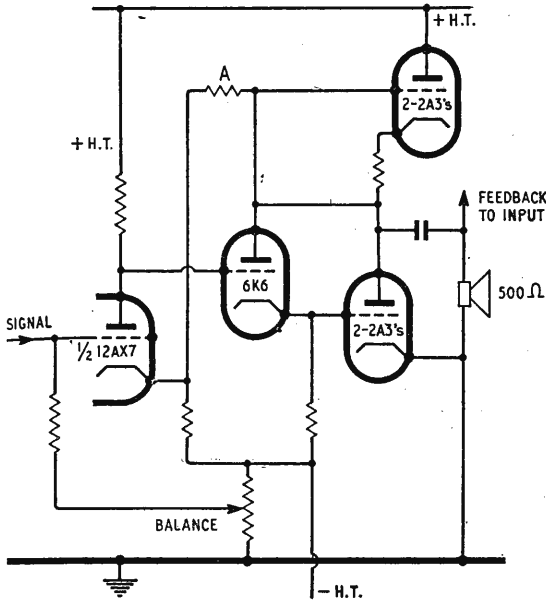

Fig. 2. Stephens amplifier.

this line is described by Fletcher and Cooke.⁴ The authors use a simple push-pull cathode follower arrangement shown schematically in Fig. 1. In order to obtain 12 watts of peak power in a 16-ohm loudspeaker 16 6AS7Gs were necessary. No distortion figures were quoted, and the damping was not very good (the output impedance was 23 ohms) but the authors did not use any overall negative feedback. In such cathode follower circuits low-impedance loudspeakers have an advantage in that the voltage requirements from the driver are not so serious as is usually the case.

Series Connected Output Stages.—Most other circuits use a series connected output stage, with either a single or push-pull input to this stage. In either case since the valve outputs in the load add together the optimum value for this load is less than half of that in the conventional push-pull arrangement. This type of circuit thus considerably eases the matching problem. It is also often easier to arrange d.c. connections between earlier stages and the output valves which improves the low frequency response and decreases the phase shift in this region.

Using a single input, series connected, output stage two commercial amplifiers have been developed, by Stephens⁵ and Phillips,⁶ both for capacity connected high-impedance loudspeakers. Schematic

diagrams for these are shown in Figs. 2 and 3. In both cases the signal from the lower output valve is fed to the grid of the upper so that the input signal varies the voltage across the output valves in opposite directions. More complicated power supply arrangements could have avoided the necessity of capacity connections to the loudspeakers. The circuit of the Stephens amplifier shows how d.c. connections between early stages may be arranged in this type of circuit. The resistor A provides negative feedback and serves to stabilize the bias on the 2A3s. With about 40 dB of feedback 3rd harmonic distortion is of the order of 0.4 per cent for 20 watts r.m.s. output into the 500-ohm load. Unfortunately, in both these amplifiers the voice coil does not provide a sole common load for the two output valves because they also partially load each other. Although cancelling of even harmonic distortion products could still be obtained by arranging for the output valves to give equal amounts of such distortion in the voice coil, this balancing would be difficult if not impossible, with the few variables available.

Push-Pull Series Connected Output Stages.—The last-mentioned disadvantage does not apply if the

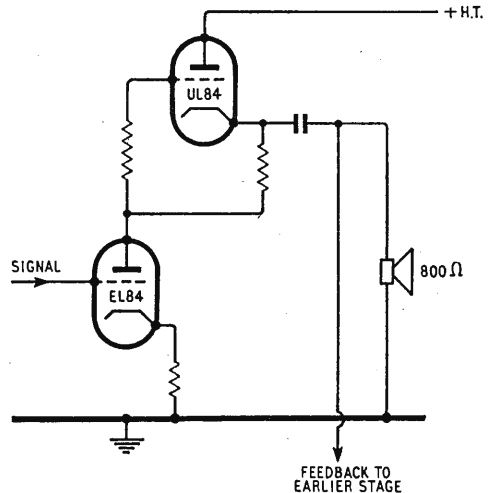

Fig. 3. Phillips output stage.

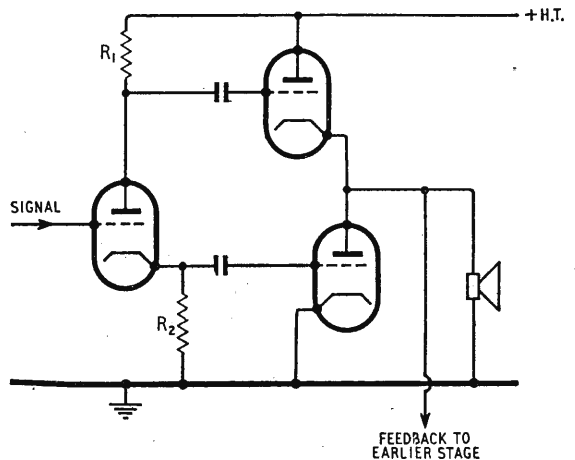
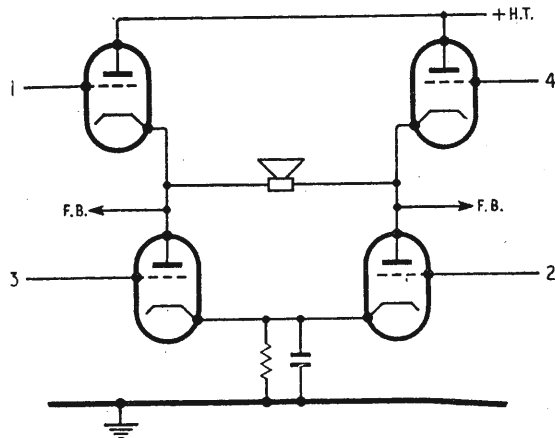

Fig. 4. Dickie-Macovski output stage.

output valves are series connected with push-pull input. In this case the optimum output impedance is one quarter of that for normal push-pull operation. If, however, the phase splitter and output valves are not correctly designed together it is difficult to retain equal drive in the output valves as the loudspeaker impedance changes.

An example of this difficulty arises in an amplifier described by Dickie and Macovski.⁷ Omitting a push-pull driver stage the phase splitter and output stages are schematically as in Fig. 4. Here it will



Above: Fig. 5. Ouder output stage.

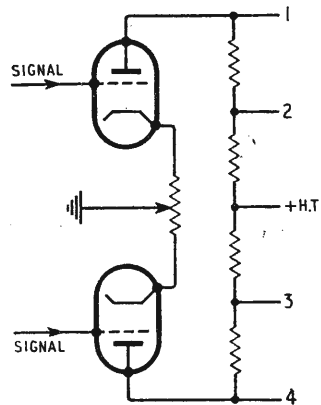

Left: Fig. 6. Ouder driver stage.

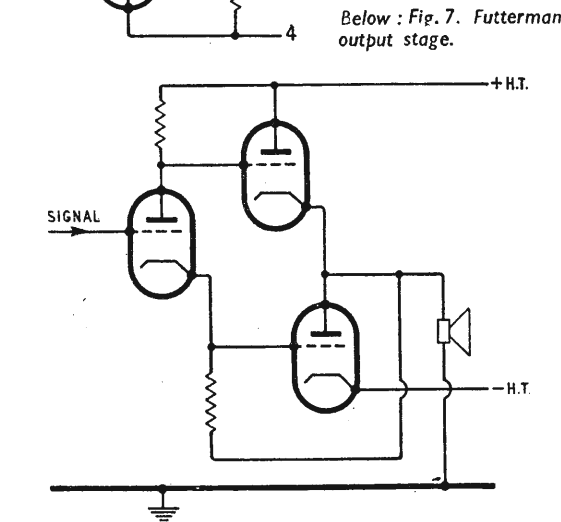

Below: Fig. 7. Futterman output stage.

be seen that the voice-coil load is coupled so that it provides feedback to the grid of the upper valve. Thus the input to this valve has to be increased and the resistor R_1 is made greater than R_2 . However the variation of voice-coil impedance over the frequency range (which may easily be of the order of 5 to 1) prevents exact adjustment by this means except over a narrow frequency band. In this amplifier the effect of this impedance variation is reduced by suitably shunting the voice coil; an example of such a shunt being simply a .01- μ F condenser and a 16-ohm resistor in series. This prevents the rise in impedance at high frequencies produced by the inductive voice coil and thus avoids instability caused by increased feedback and phase shift. The anode loads of the push-pull driver stage could also be adjusted to give better balance.

In this amplifier there is one voltage amplifying stage before the phase splitter and 3 6082 valves (26.5 volt versions of the 6AS7G) operating nearly in class B in the output stage. With 40 dB of overall feedback the harmonic distortion was 0.4 per cent for 25 watts r.m.s. into a 16-ohm load.

Essentially the same balancing difficulty arises in a variation of the circuit of Fig. 4 described by Ouder.⁸ Here instead of simply paralleling output valves to give increased power they are arranged in a bridge circuit (shown schematically in Fig. 5) which increases the optimum load to four times that for a parallel arrangement. Diagonal valves are run in phase, suitable driving voltages being obtained from a push-pull stage as in Fig. 6, this arrangement giving the necessary greater input to the upper tubes. An ordinary "concertina" phase splitter with suitable tapings on the loads could, of course, also be used. Here again using a balancing potentiometer as in Fig. 6, d.c. connections become possible.

In this amplifier there is a "see-saw" type of phase inverter before the driver, and 2 6AS7G valves operating in class A in the output stage. With about 15 dB overall feedback the intermodulation distortion was 0.7 per cent for 9 watts into a 400-ohm load.

Equalization of Drive in the Output Valves.—If we return now to Fig. 4 equal drive in the output valves can be obtained very simply as described by Futterman,⁹ by returning the earthy end of R_2 to the junction of the output valves as in Fig. 7. In this case both output valves are acting as cathode followers so that the voltage requirements from the phase splitter are large. However, the load is in the input to this valve in the correct sense to provide positive feedback so that a much lower voltage is actually required.

In the amplifier described in this reference (Ref. 9) there is a pentode, high gain, voltage amplification stage before the phase splitter. The cathode return from this pentode is taken to the tap of a potentiometer across the load so that varying amounts of negative feedback may be applied. There was in fact some difficulty in obtaining sufficient gain to give enough feedback to reduce the distortion sufficiently, but a phase splitter giving gain could be used. Using 14 type 12B4 valves operating in class B in the output stage, with 48 dB of overall feedback the harmonic distortion was 0.1 per cent for 20 watts into a 16-ohm load. Square wave tests on this and the amplifier of reference 7 already described give very impressive results even at

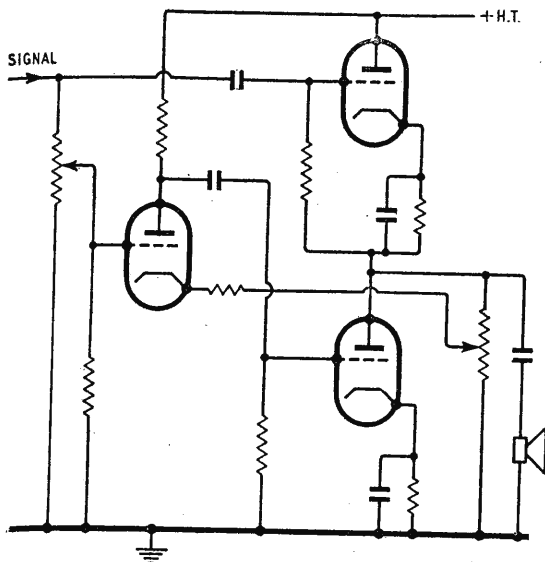

Fig. 8. Coulter output stage.

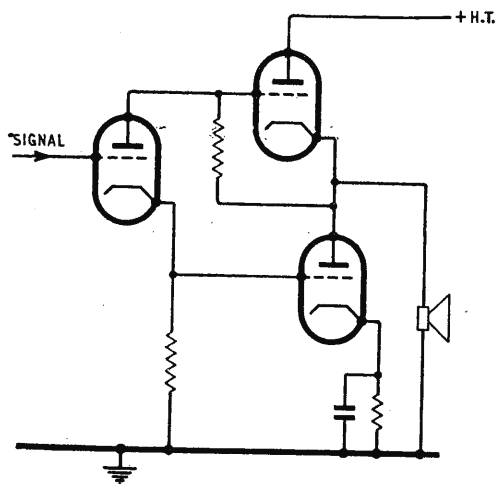

Fig. 9. Peterson-Sinclair output stage.

20 kc/s, with very short rise times and no overshoot.

A more complicated way of obtaining this equal balance, by applying extra feedback to the lower output valve in Fig. 4 is described by Coulter¹⁰ and illustrated in Fig. 8. Here the upper output valve is fed directly from the input. A suitable fraction of this input has its phase inverted by another valve and is then applied to the grid of the lower output valve. By taking the cathode feed for the phase inverter from the tap of a potentiometer across the load, negative feedback is applied to this inverter and thus to the lower output valve. The amount of this negative feedback is adjusted to compensate for that produced by the load in the upper valve.

A disadvantage of this arrangement is that the distortion in the input to the lower valve is greater than that to the upper as this input has to pass through an extra voltage amplifying stage (the phase inverter); and the even harmonics of this extra distortion cannot be cancelled in the output stage. Furthermore, the degeneration caused by the speaker varies with its impedance, whereas the feedback is a constant fraction of the output voltage.

This general type of output stage has been recently applied to a transistor circuit by Cossor's.¹¹ Transistors have an encouraging future in transformerless amplifiers as their voltage requirements are much lower, and a considerably higher overall efficiency should be possible. In the Cossor circuit equal drive in the output transistors is obtained by an input transformer. This transformer also avoids d.c. unbalance in these transistors but is contrary to the general philosophy of such amplifiers.

Returning again to Fig. 4, perhaps the best way of obtaining balanced inputs to the output valves is, as described by Peterson and Sinclair,¹² to take the anode supply for the phase-splitter from the junction of the output valves as in Fig. 9. In this case the input voltages to the output valves are always developed between cathode and grid, so that the load does not produce a cathode follower effect

in either valve and there is no unbalance. A disadvantage is the negative feedback produced by the load on the supply voltage for the phase-splitter. This circuit also is susceptible to d.c. connection.

The authors give a general discussion of this type of amplifier using transformers solely as matching devices. No practical details of a strict transformerless amplifier are given.

Extended Class A?—Another novel type of circuit that may perhaps be of value in these amplifiers was given the name, "extended class-A," by the author.¹³ Here a triode and tetrode are run in parallel with their grids and anodes directly connected. The valves are biased for normal class A operation for the triode and this usually cuts off the tetrode, so that the arrangement acts as a triode for small signals. When the signal becomes sufficiently large (usually about one third of the maximum) the tetrode starts drawing current and increasingly controls the operation. This gives the transfer characteristic a slight curve but this is not serious. The circuit should combine the advantages of the low output impedance of triodes with the high current carrying characteristic of tetrodes. The idling anode current also is only about one third of the usual amount; or, in other words, for a given valve the maximum power obtainable is greatly increased.

Power Supplies.—It will be noted that the schematic diagrams in many cases envisage more than the usual number of power supplies, especially when those for screens and grids are worked out, and particularly if d.c. connections are desired. This complication is not as great as may be imagined when voltage doubling circuits, the avoidance of mains transformers, and direct series running of the heaters are considered. Moreover, due to the large amounts of negative feedback used, the hum in the output is generally reduced so much that chokes need not be used in the supplies. In fact, such chokes are often undesirable, as the impedance of the h.t. supply to the output valves must be low compared with the load to avoid loss of power.

Practical Choice of Output Valves.—To return to

some earlier remarks, one of the biggest practical difficulties is simply that of obtaining output valves that can pass the necessary current. Here from the cost point of view more than one valve will almost certainly be required for each side of the output stage. Bearing in mind that certain valves can be obtained very cheaply, it may be more economical to use a large number of one valve rather than fewer of another. Valves made primarily for other purposes, such as television line scan or current stabilization, can also sometimes be of use. The resultant optimum load should, of course, be made as small as possible, though increased distortion due to mismatch may be removable by sufficient feedback.

REFERENCES

- ¹ F. H. McIntosh and G. J. Gow, "Description and Analysis of a New 50-watt Amplifier Circuit," *Audio Eng.*, Vol. 33, December 1949, p. 9.
- ² V. Brociner and G. Shirley, "The Output-Transformer-less Amplifier," *Audio Eng.*, Vol. 36, June 1952, p. 21.
- ³ For another method see H. A. Watt, "The Post-ultimate Amplifier," *High Fidelity*, Vol. 6, April 1956, p. 62.
- ⁴ E. W. Fletcher and S. F. Cooke, "Cathode-follower Loudspeaker Coupling," *Electronics*, Vol. 24, November 1951, p. 118.
- ⁵ F. H. Gilbert, "Commercial O-T-L Amplifier of Unique Design," *Audio Eng.*, Vol. 36, August 1952, p. 46; and F. H. Gilbert, "An A.F. Amplifier Without Output Transformer," *Radio and Television News*, March 1953, p. 45.
- ⁶ *Wireless World*, Vol. 62, October 1956, p. 475, and *Wireless and Electrical Trader*, Vol. 103, September 1st 1956, p. 618.
- ⁷ D. P. Dickie, Jr., and A. Macovski, "A Transformerless 25-watt Amplifier for Conventional Loudspeakers," *Audio Eng.*, Vol. 38, June 1954, p. 22.
- ⁸ K. Onder, "A New Transformerless Amplifier Circuit," *Journal of the Audio Eng. Soc.*, Vol. 1, October 1953, p. 282; and K. Onder, "Audio Amplifier Matches Voice-Coil Impedance," *Electronics*, Vol. 27, February 1954, p. 176.

⁹ J. Futterman, "An Output-Transformerless Power Amplifier," *Journal of the Audio Eng. Soc.*, Vol. 2, October 1954, p. 252.

¹⁰ W. H. Coulter, "Amplifier Circuit having Series-connected Tubes," U.S. Pat. No. 2,659,775, Brit. Pat. No. 688,273. This patent is described in *Audio Eng.*, Vol. 38, March 1954, p. 2.

¹¹ *Electrical and Radio Trading*, Vol. 32, October 6th 1956, p. 54.

¹² A. Peterson and D. B. Sinclair, "A single-ended Push-pull Audio Amplifier," *Proc.I.R.E.*, Vol. 40, January 1952, p. 7.

¹³ H. T. Sterling, "Extended Class-A Audio," *Electronics*, Vol. 24, May 1951, p. 101.

B.B.C. Facts and Figures

OVER 20% of the 14,519 members of the B.B.C. staff are classified as being in technical engineering.

The total staff engaged exclusively on work for the television service is 3,700—about 25% of the whole.

Nearly 24% of the £11M spent during the last financial year on the sound services (excluding overseas transmissions) was devoted to engineering. Of this sum £237,269 went to the Post Office for rental of lines.

Of the £7M expended on television, 42% (£2.95M) was debited to engineering. Over half a million pounds was paid to the Post Office for lines.

The Post Office received, in all, nearly £1M from the B.B.C. for the rental of lines during the year ended last March.

During 1955-56 the gross licence income was £25.736M. Of this sum the Treasury took £2.75M and the Post Office retained £1.784M, leaving the B.B.C. £21.2M.

Thirty-nine high-power, short-wave transmitters and 177 aerials are used for the B.B.C.'s external services.

Over 20,000 hours of B.B.C. recordings were transmitted in 1955, and during the last five months of the year tape accounted for 70% of the total.

These facts and figures are culled from the "B.B.C. Handbook, 1957" (B.B.C. 5s), and the "Annual Report and Accounts of the B.B.C., 1955-56" (H.M.S.O. 6s).

SHORT-WAVE CONDITIONS

Prediction for February

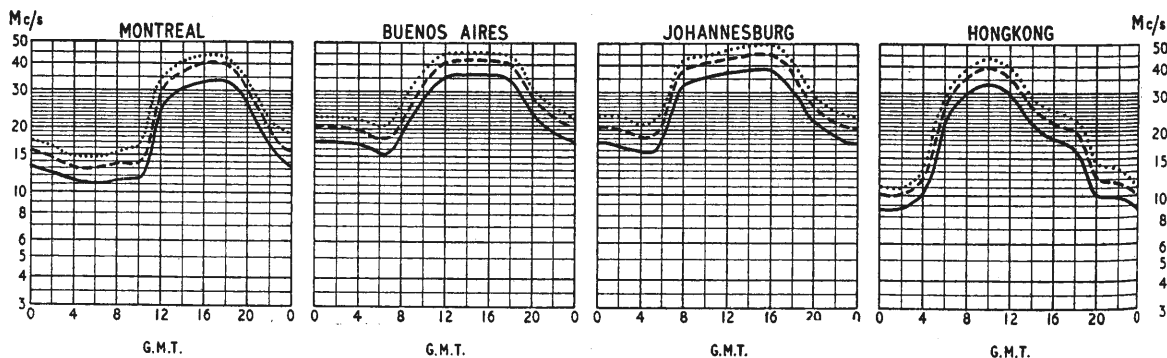

THE full curves given here indicate the highest frequencies likely to be usable at any time of the day or night for reliable communications over four long-distance paths from this country during February.

Broken-line curves give the highest frequencies that will sustain a partial service throughout the same period.

- FREQUENCY BELOW WHICH COMMUNICATION SHOULD BE POSSIBLE FOR 25% OF THE TOTAL TIME
- PREDICTED AVERAGE MAXIMUM USABLE FREQUENCY
- FREQUENCY BELOW WHICH COMMUNICATION SHOULD BE POSSIBLE ON ALL UNDISTURBED DAYS

Automatic Component Assembly

By K. M. McKEE*

B.Sc., A.M.I.E.E.

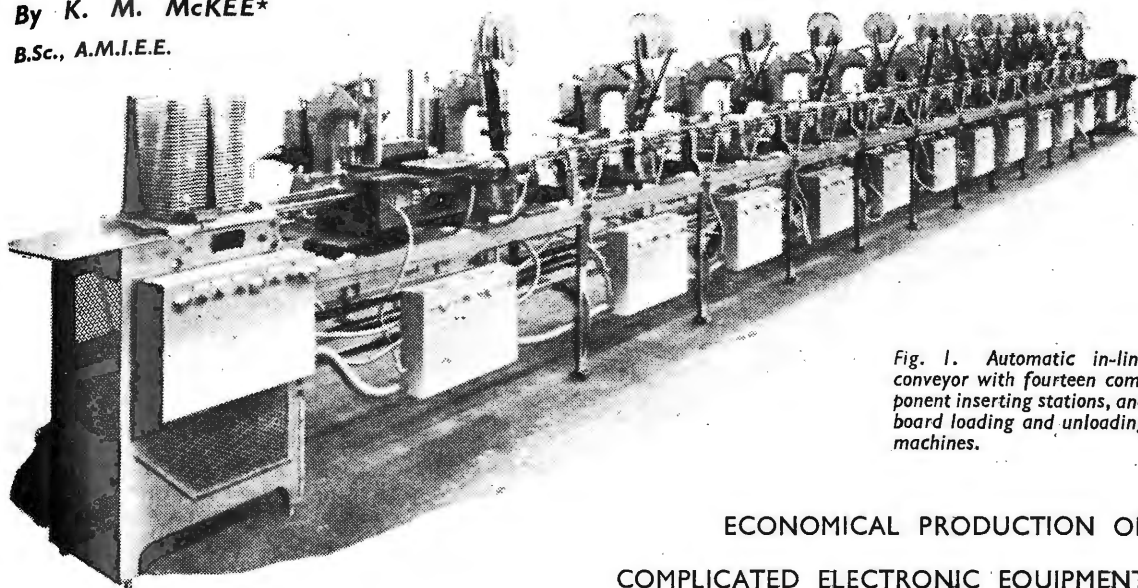

Fig. 1. Automatic in-line conveyor with fourteen component inserting stations, and board loading and unloading machines.

ECONOMICAL PRODUCTION OF COMPLICATED ELECTRONIC EQUIPMENT

WITH the remarkable rate of growth of the electronic industry during the past twenty years it is not really surprising that the production side has had little time to investigate fundamentally new methods of circuit construction. Development engineers have been more than fully occupied incorporating in their designs improved components and rapidly developing circuit techniques, and at the same time in maintaining prices at a level which compared favourably with competitors.

The conventional form of the electronic circuit appears to have been derived from the larger and more robust electrical power installation, in so far as both consist essentially of independently manufactured units interconnected by wires. While this form of electronic circuit offers flexibility in construction, its reproduction in quantity involves a multitude of point-to-point wires, terminals, insulators and metal fittings. The result has been a high labour content and the existence of numerous possible sources of error in assembly. It is significant that on a normal assembly line in the radio and television industry one inspector is required for every five operatives.

A further difficulty lies in the fact that random effects due to minor differences in wiring layout make it hard to obtain consistent standards of performance, particularly where high frequencies are involved. Moreover, the variable and complex nature of the layout itself allows very limited scope for employing mechanical aid to improve the rate and general efficiency of assembly.

Advent of the Printed Circuit.—It has become clear that if industry is to meet the demand for an increased volume of more complicated electronic circuits at reduced cost, the basic form of circuits

would have to undergo a radical change in order to introduce the machine into every stage of production. Various schemes have been evolved using a variety of methods, several of which have involved producing complete electronic circuit assemblies from basic material. In this connection it has proved not at all easy to reproduce in the circuit elements that go to make up these assemblies the reliability and tolerances associated with orthodox components. After all, the characteristics of standard components have been built up as a result of years of development and production experience.

The form of assembly that has now gained wide acceptance is the combination of standard components and printed-wiring boards. Printed-wiring boards etched from copper-clad phenolic laminate have the great merit from the production standpoint that all conductor terminations are fixed in position and in a single plane. Above all, mechanized processing can be applied in turning out identical wiring boards, so forming a suitable basis for automatic assembly and subsequent mechanized operations.

It has been estimated in the report¹ of a comprehensive survey conducted on behalf of the U.S. Navy that with assemblies produced in this way, the labour content is reduced thirty times in comparison with conventional methods; in both cases production capacity and rate were assumed to be constant. To assist in achieving this remarkable saving in human effort, the report recommends the adoption of automatic multi-station in-line machinery for the assembly of standard components on the printed-wiring boards.

Automatic Assembly Machinery.—Fully automatic assembly machinery may be divided into two types; programmed single-station machines and multi-station in-line conveyor systems. Programmed

*Geo. Tucker Eyelet Co. Ltd.

single-station machines have a relatively low rate of output, are costly, and complicated in concept and action. Accurate programmed tapes are necessary; though once the tapes have been made, no other machine setting-up routine is necessary. The field of application lies chiefly in the assembly of batches of very short production runs.

The alternative is the multi-station in-line conveyor system where the intricate assembly operation is broken down into a number of easy stages, which in turn implies a series of simple and reliable mechanisms. Separate pre-set machines are mounted on a transfer conveyor, each machine (or station) inserting a single type of component into the printed-wiring boards as they pass down the line. The machines are arranged to operate simultaneously so that on completion of each machine inserting cycle an assembled wiring board emerges at the end of the line. Although the movements of an in-line transfer conveyor could hardly be described as fast, surprisingly high output rates of

up to 1,200 assembled boards an hour can be regularly maintained. What is more, the conveyor may be extended to accommodate any number of additional machines without change of output rate; though a line of forty stations is now regarded as the practical upper limit.

Application in Industry.—Early in 1956, eighteen in-line transfer conveyors were in regular operation in the factories of leading United States electronic manufacturers. The most widely used system was that incorporating "Dynasert" automatic equipment. This machinery is now being developed and manufactured in this country, and is being made available to the British electronic industry by the Geo. Tucker Eyelet Company under the "Dynasert" trade mark.

The first of these conveyors to be installed in the United Kingdom is at present in production on a commercial basis at the Ekco factory at Southend, and a second is shortly to be in operation in the works of another well-known British radio and television manufacturer. During the past year, as a preliminary step to full automatic assembly, six other manufacturers have purchased machines modified as manually operated bench machines. These machines (which will later be described in greater detail) can readily be converted for use on a fully automatic conveyor.

Conveyor Operation.—The conveyor, Fig. 1, consists essentially of a transfer machine for transporting the printed-wiring boards, and bringing each in turn into an accurately located and firmly locked position beneath the inserting machine heads at every station. The phenolic laminate material of the printed-wiring board is unfortunately inclined to be dimensionally unstable, particularly after having been subjected to unavoidable temperature cycles during the etching and punching process. It has been found that mounting the board on a light alloy frame or pallet for assembly, as shown in Fig. 2,

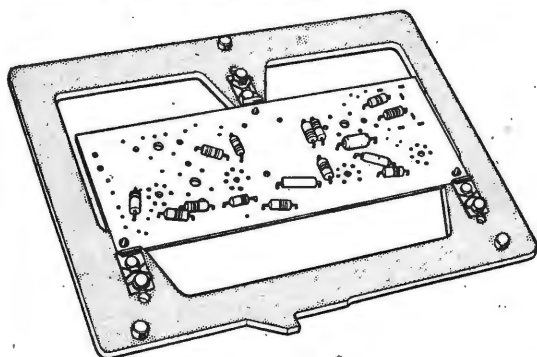

Fig. 2. Conveyor pallet complete with printed-wiring board and assembled axial-lead components.

Fig. 3. Simplified diagram showing the circulation of pallets on the forward and return conveyor belts. The electrical control system is illustrated comprising micro-switch units and machine-control panels at each station, together with the conveyor-control panels on the end sections.

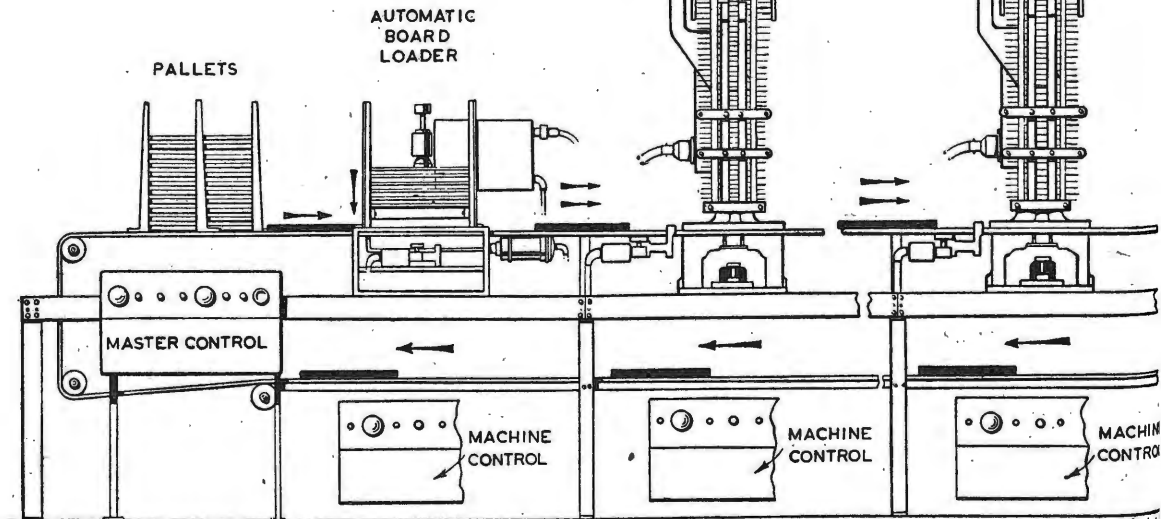
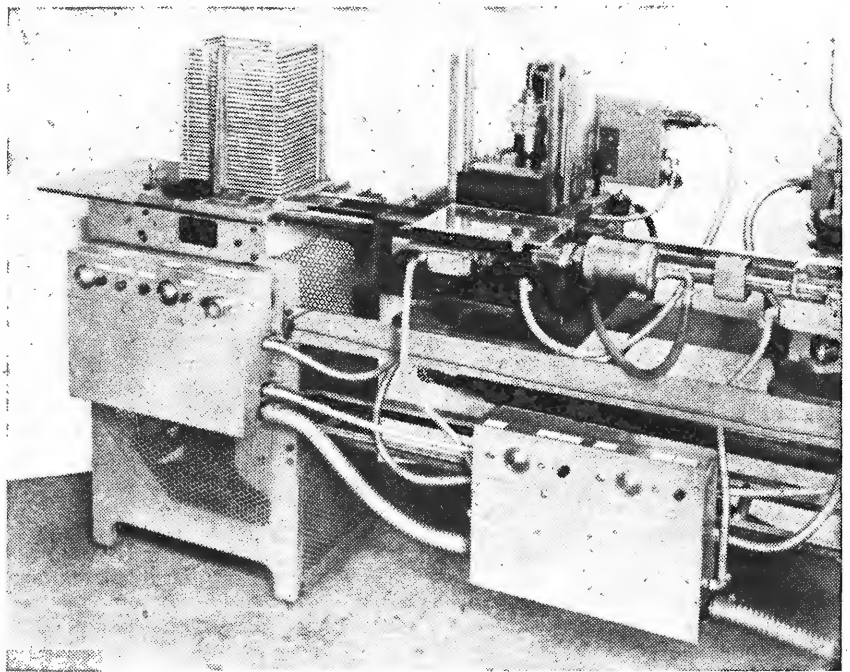

Fig. 4. Loading end of the conveyor with stack of empty pallets and loading unit for mounting printed-wiring boards on pallets prior to component assembly.

assists accuracy of location and enables a range of board shapes and sizes to be accommodated without adjustment to the conveyor.

A simplified drawing illustrating the action of the conveyor and the circulation of the pallets is shown in Fig. 3. Pallets are stacked at the left-hand end of the conveyor and are released one at a time on to a set of twin conveyor belts (see C in Fig. 5) which are continually in motion while the conveyor is in operation. At the next station, printed-wiring boards are automatically fed beneath the ram plate of a pneumatic press, Fig. 4, which thrusts the board downwards between the spring clips on the pallet. The board is firmly held on the pallet by steel pins which fit into accurately punched location holes at the edges of the board, Fig. 2. One of the holes must be round, the remainder may be drawn to allow for any change that may have taken place in the lateral dimensions of the board.

The pallet with the board is now released and transported by the conveyor belts to the first inserting station, where it is lifted from the belts and solidly locked beneath the machine head. On com-



pletion of the inserting cycle, the pallet is once more released. In this way, a series of pallets carrying printed-wiring boards proceeds down the line until the board-unloading station is reached at the distant end. Here the reverse of the loading process takes place, with the boards being pushed from the pallets by a ram press acting from underneath. Fingers on arms incorporated in the unloader unit lift the boards, which then slide off down a chute (not shown). The empty pallets are tripped off the forward moving belts and descend by another chute to the lower return conveyor, where they pass back to the head of the line. It will be observed that only a small number of pallets is required to maintain circulation, plus a few extra to form a reserve in the stack.

The sequence of action in the conveyor is controlled electrically by timing relays in the master-control box indicated in Fig. 3. A micro-switch is mounted on the conveyor at each station, M in Fig. 5, which is tripped by a projection on the side

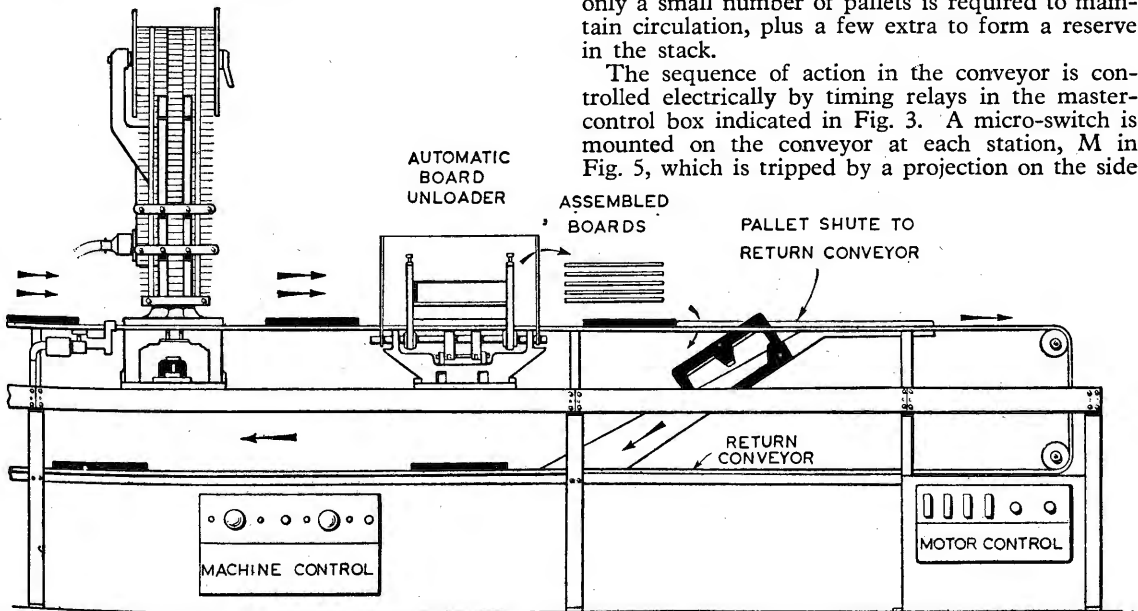

of each pallet, Fig. 2, when the pallet reaches a station. The micro-switches are connected in a series circuit, so that only when every pallet has arrived at its station will the circuit be complete, and the timing relay actuated in order to allow the insertion cycle to commence. The circuit thus serves as an interlock to arrest action should a serious conveyor stoppage occur, in which event a signal light on the machine control box in question is illuminated to attract attention. Switches fitted to each machine control box enable units to be operated independently or isolated from the main control circuit.

Component Inserting Units.—Over 70% of the components used by the electronic industry for radio and television equipment are of the axial-lead type, and the vast majority of these are of the $\frac{1}{4}$ -W resistor size or smaller. In considering the design of automatic inserting machines, it was obviously essential to develop a rugged and reliable unit at reasonable price to handle this particular range. The No 1 "Dynasert" component inserting machine illustrated in Figs. 5 and 6 has proved to be capable of maintaining an insertion reliability of better than 99.8%.

A high insertion reliability of this order is vital if the operation of a line of automatic machines is to be a practical proposition. For instance, if the machine insertion reliability was only 95%, according to the laws of probability with ten machines in line, 40% of the assembled printed-wiring boards would contain a misplaced component. On a similar conveyor having a machine insertion reliability of 99.8%, the corresponding figure would be less than 2%. Good mechanical design and precision workmanship in making machine inserting head parts are required for high insertion efficiency.

Apart from axial-lead components, machines are in course of development for handling flat and disc radial-lead capacitors, and a wide variety of printed circuit valve bases. Another machine of this type is also being developed for inserting printed circuit sub-assemblies, consisting of a number of components mounted on a small printed-wiring board. The sub-assembly may be made up on a conveyor with the manufacturer's own choice of components, or, alternatively, purchased as a packaged item from a component maker. Sub-assemblies when mounted vertically on a larger printed-wiring board introduce a third dimension to the layout, and their application in certain circuits leads to economy in board area.

A further range of conveyor machines has been planned for placing eyelets, tags and special terminals, which are often needed for interconnecting wiring between one printed-wiring board and another, and from them to the larger units used with electronic equipment.

Axial-lead Component Machines.—Machines for axial-lead components will be made in three sizes, which depend mainly on the dimensions of the component body to be handled and the corresponding lead-hole spacing on the printed-wiring board. The two sizes of unit at present available will handle components of the smallest body length and a minimum body diameter of $\frac{3}{16}$ in up to approximately 1in body length and $\frac{3}{16}$ in diameter. The third unit is being designed to insert components with maximum body dimensions of $2\frac{1}{2}$ in in length and 1in in diameter.

Also, a modified version of the axial-lead component machine has been developed for inserting jumper wires. Jumper wires are cut from a reel of plain or coated wire; then formed, inserted, and clinched in a similar manner to axial-lead components. Circuit designers have found jumper wires of special value in solving printed-wiring layout problems, as they are able to form a useful bridge connection between any two printed conductors.

For feeding purposes, axial-lead components are belted on reels before being loaded on to the machine. It is hoped that component manufacturers will soon make their standard axial-lead components available in belted form. "Dynasert" belting machines which straighten out slight bends and kinks in the leads and belt-up the components on reels, are soon to be available for use by both component and electronic equipment manufacturers. It is now generally accepted that reels of belted components with straight leads provide a most economical and efficient method of packaging for all applications.

The machine shown in Figs. 5 and 6 is a typical example of the units used for inserting belt-fed components. Components on leaving the reel slide down the guide bars G, which are of sufficient length to allow reels to be changed without interfering with continuity of operation. The leads are then engaged either side of the body by grooves cut round the peripheries of two feed wheels, Fig. 7, and drawn under the inserting tools in the head. On air being released in to a pneumatic cylinder, Fig. 6, which is mounted in the frame, F in Fig. 5, the tools are thrust downwards towards the printed-wiring board. In the process, excess length is trimmed from the leads, which are then formed through a right-angle at each end, and driven down and through the pre-punched holes in the board. The remaining wire trimmings are carried clear of the inserting mechanism by the tray T, Fig. 5, still attached to the tapes.

The pneumatic cylinder through a separate lever system raises two anvils, Fig. 7. The leads on emerging from the underside of the board are clinched over by the anvils in any pre-set direction, the ends being normally arranged to lie along the printed conductors, as indicated in Fig. 8. Experience of many millions of insertions in the U.S.A. has shown that leads clinched in this way greatly assist the formation of sound dip-soldered connections to the printed wiring.

Referring to Fig. 7, a resistor is represented in three of the stages of insertion and clinching.

The overall cut-off length

$$I' = L + D + d + 2(t + s + c)$$

Substituting the values of dimensions in the brackets, which are recommended in the majority of cases:

$$I' = L + D + d + 2 \left(\frac{1}{8} + \frac{1}{8} + \frac{1}{8} \right) \text{ inches}$$

i.e., $I' = L + D + d + \frac{1}{2}$ inches.

Production Change-over.—Lack of flexibility in production change-over has in the past rendered some previous systems of automatic assembly impractical under modern working conditions. This could scarcely be said of the multi-station in-line system, where adjustment from one layout of printed-wiring board to another usually takes less than six minutes per station.

Inserting machines are secured in position on

Fig. 5. Drawing of an axial-lead component inserting machine mounted on the conveyor. A pallet with partially assembled printed-wiring board is shown beneath the inserting head.

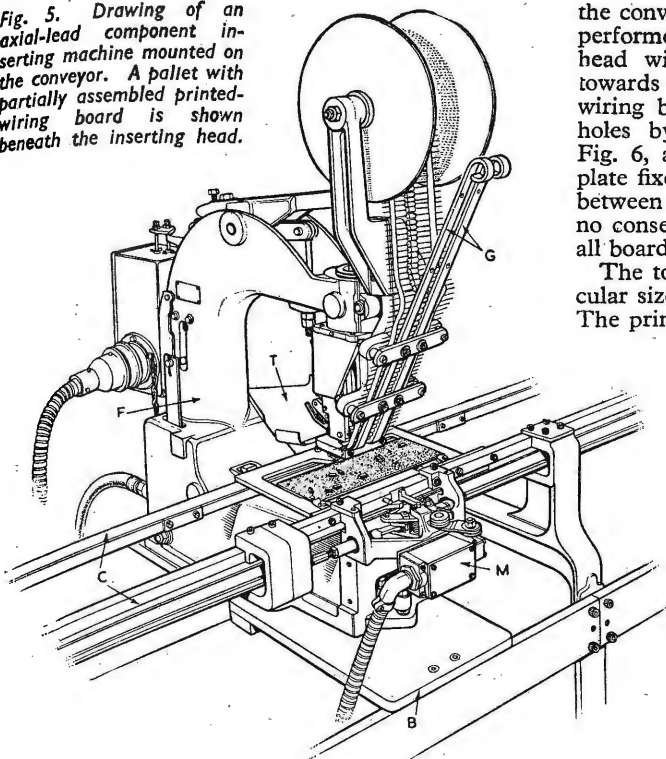

the conveyor by a single clamping screw. Setting is performed by lowering the tools in the inserting head with the leads of a component projecting towards the appropriate set of holes in a sample wiring board. The leads are aligned against the holes by rotating the head about a vertical axis, Fig. 6, and adjusting the unit itself about a base plate fixed to the conveyor frame. Punching errors between sets of component lead holes are clearly of no consequence provided the error is consistent on all boards.

The tools in the head are designed for one particular size of component body and lead-hole spacing. The principle adopted is that the lead-hole spacing

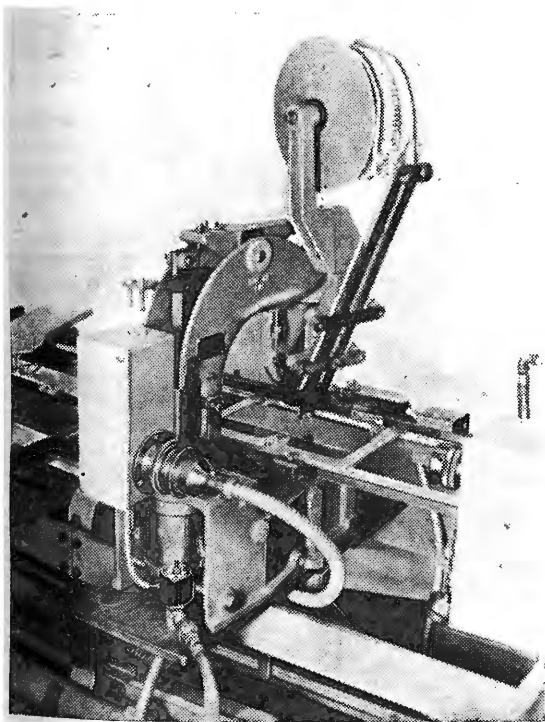

Fig. 6. Rear view of an axial-lead component inserting machine about to place a component. The inserting head has been rotated to align the component leads to the pre-punched holes in the printed-wiring board.

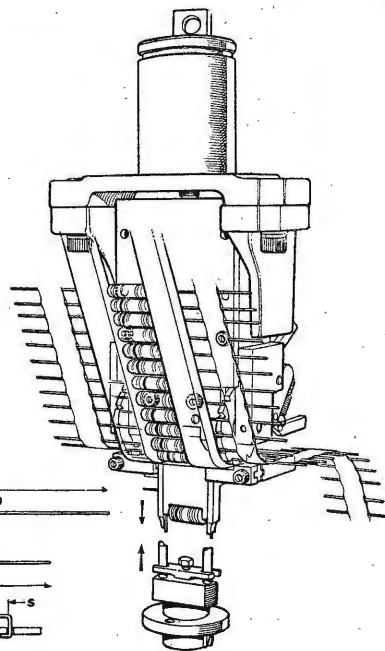

Fig. 7. Inserting mechanism of axial-lead component machine including anvils, with the feed wheels in the head shown through the tapes carrying components down for insertion. Note how the remaining wire trimmings are transported clear of the mechanism by the tapes. On the left, a resistor is represented in three of the stages of insertion and clinching to the printed-wiring board.

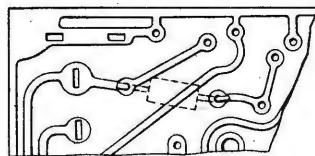

Fig. 8. Portion of a typical printed-wiring board viewed from the printed circuit side. A resistor is shown in position with the end of its leads clinched over to follow the direction of the printed conductors.

is a function of the component dimensions rather than the printed circuit. To avoid mechanical difficulties and the high cost associated with small variable setting devices, it was decided to produce tools for a range of standard hole spacings, with dimensions of the most used components in mind. Special tools can, however, be made for any lead-hole spacings within the limitations imposed by the dimensions of the component and machine head.

A conveyor station may be converted from feeding

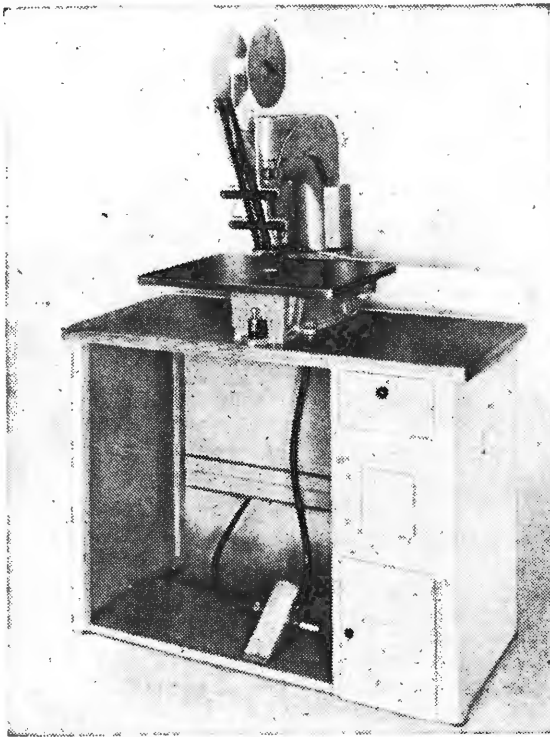

Fig. 9. Machine modified for bench operation showing the operator's foot control and with the safety cover guards in position on the machine.

one component to another of different dimensions by substitution of (i) the machine, or (ii) the inserting head, Fig 7, or (iii) the tools in the inserting head. The change-over in (i) and (ii) may be carried out by an unskilled operator in a matter of minutes, (iii) involves the services of a skilled mechanic for about 20 minutes.

Semi-automatic Production.—For short production runs conveyor machines may be mounted on a work table, Fig. 9, and employed as individual bench units. Only minor modification is required to the air control system of the conveyor model, for foot operation. Several such units could be adapted to cover a large percentage of the components needed for the circuits on most printed-wiring boards. Furthermore, by stripping the component-feed fittings from the head, a bench machine may be converted to a component cutting and forming unit, which is occasionally required by manufacturers for the preparation of special components prior to manual insertion.

Fig. 10 shows a close-up view of an optical location attachment fitted to the bench machine in Fig. 9. The arrangement projects two narrow beams of light on to a mirror, which reflects the light and produces two bright spots on the printed-wiring board. The board is quickly manipulated until the spots of light disappear down the required pair of holes, the foot pedal is depressed and the machine inserts and clinches the component. For a large batch of boards, it is preferable to use the arrangement as a setting-up aid for magnetic stops attached to the metal table, subsequently using the stops as a location jig for positioning the boards.

In comparison with manual performance of the same work, the machine shows a marked saving in time, and practically no operator fatigue has been experienced over long periods of operation.

Designing for Automatic Assembly.—Perhaps the most satisfactory feature of the new automatic production techniques from the point of view of the designer is that he has now almost complete control over the final performance of the circuit that he designs. If he succeeds in obtaining good results from a prototype in his laboratory, there is no reason why that performance should not be repeated in practically every model produced on the factory floor. On the other hand his responsibility is now much greater than it used to be. His design must be entirely free from error because it will often be an extremely costly matter to rectify a mistake once production has commenced. In the author's experience, most designers in the industry have welcomed the change and are only too willing to accept the increased responsibility entailed.

Many firms are now in the difficult stage of transition, where they are attempting to adapt designs and layouts that were intended for conventional wiring. This is nearly always a most difficult task to accomplish satisfactorily, and it is usually quicker to scrap the original layout and start again. In the United States, where now nearly 90 per cent of the mass-produced electronic equipment is on printed wiring, it has been found that three to five boards are most suitable for a television receiver, and one or two for a radio receiver. Hole-positional errors outside the tolerances required for automatic assembly, servicing problems, and breakages in punching, have turned the scales against the use of large-size wiring boards. It is now generally recognized in all fields of production engineering that the product must be designed with automatic production in mind.

Component manufacturers have also realized that parts developed for flexible wiring create serious mechanical problems in their assembly on printed circuits. The new tendency is for leads to become stouter and shorter, with larger and awkwardly shaped components fitted with snap-in type connections. Physical dimensions will have closer tolerances and a high degree of standardization among

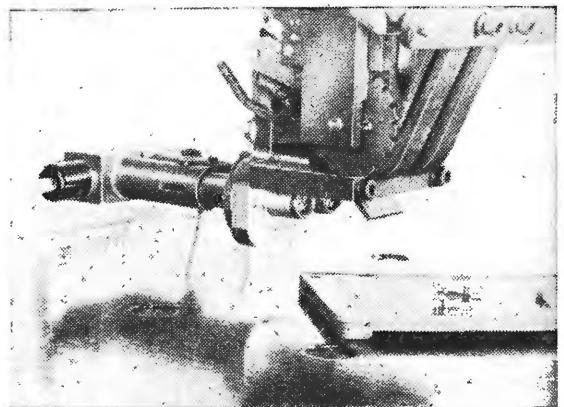

Fig. 10. Optical location attachment fitted to a bench machine to facilitate positioning of the printed-wiring board before insertion of a component.

various manufacturers' products will become increasingly important.

Advantages for the Future.—It might well be asked what is on the credit side for the effort and capital that will be expended in changing from the old to the new manufacturing techniques. There is little doubt that substantial financial savings will be possible in production costs, not so much by considering any single process on its own, such as automatic assembly, but by evolving a complete flow-through production system commencing with mechanized processing of printed wiring and followed by automatic assembly, mechanized dip-soldering, and automatic electrical testing. Among other outstanding advantages are increased uni-

formity and reliability of the final product with far less inspection, rapid production change-overs and a massive production potential available to meet any emergency or unforeseen increase in demand.

REFERENCES

¹ "New Horizons for Electronic Assembly." Navord Report 5143 compiled by Stavid Engineering Inc., for the Dept. of the Navy, Bureau of Ordnance, Washington 25, D.C.

² A description of "Dynasert" machinery was first published in articles by the author entitled "Automatic Component Assembly for Printed Circuits." *Journal I.E.E.*, Vol. 2, Sept. 1956, and "Dynasert Automatic Component Assembly Machines for Printed Circuits," *Machinery*, Vol. 89, Nov. 16th, 1956.

B.B.C. F.M. Transmitter Performance

SOME insight into the standards of quality specified by the B.B.C. and provided by the manufacturers of the transmitters now being installed for the v.h.f. service is given in papers* recently read at the Institution of Electrical Engineers and to be published in the Proceedings (1957, Vol. 104, Part B).

Two systems of modulation are being used: the transmitters supplied by Standard Telephones and Cables make use of balanced reactance-valve modulation of a free-running oscillator whose centre frequency

is controlled by reference, after frequency division, to a low-frequency crystal standard, and those supplied by Marconi's Wireless Telegraph Company rely on the "FMQ" system in which a low-frequency crystal-controlled oscillator is directly modulated by a balanced susceptance circuit† and followed by frequency multiplication.

The published figures for the performance of these two systems summarized below are expressed in different ways and are not directly comparable, but they indicate the high standards achieved in the frequency-modulated v.h.f. service.

* "Frequency-Modulated Quartz Oscillators for Broadcasting Equipment." W. S. Mortley, A.M.I.E.E. "Frequency-Modulated V.H.F. Transmitter Technique," A. C. Beck, B.Sc.(Eng.), A.M.I.E.E., F. T. Norbury, A.M.I.E.E., and J. L. Storr-Best, B.Sc.(Eng.), A.M.I.E.E.

† "FMQ" W. S. Mortley, A.M.I.E.E., *Wireless World*, October, 1951.

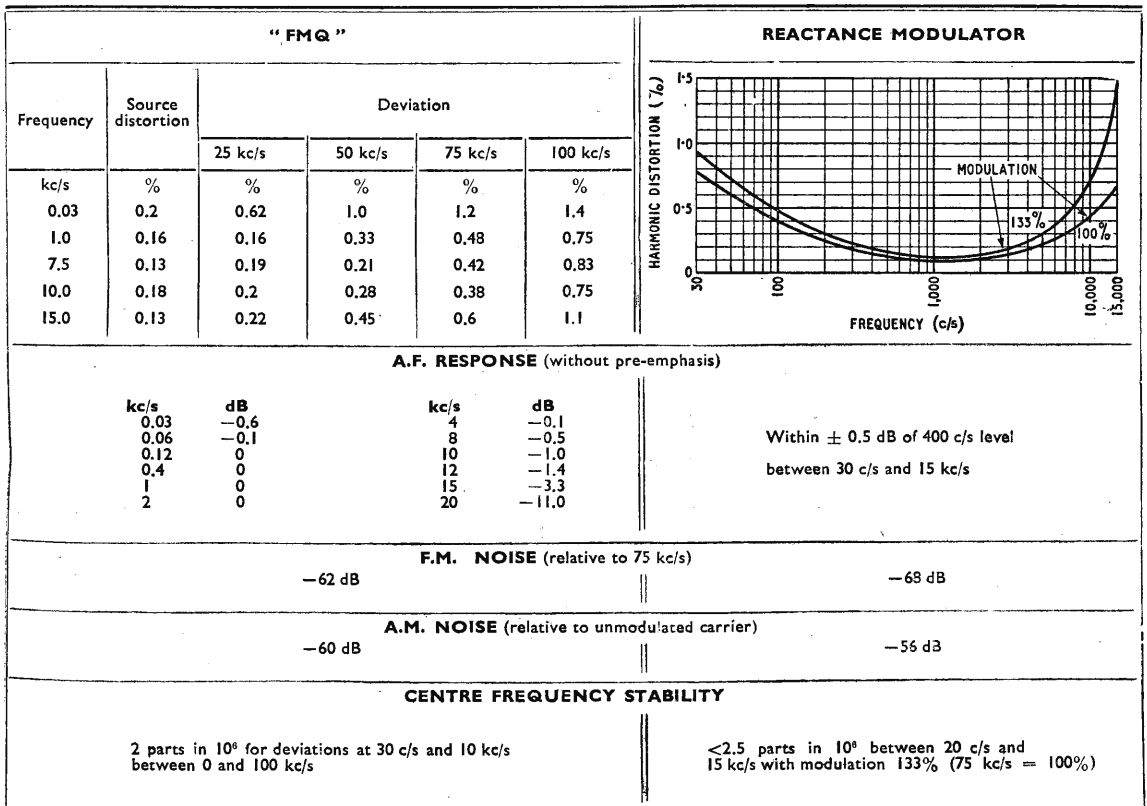

Limiters and Discriminators

2—Foster-Seeley Discriminator ; Designing for Minimum Distortion

By G. G. JOHNSTONE*, B.Sc.

THE basic type of Foster-Seeley discriminator is shown in Fig. 1. A number of variants exist in practice, and these are discussed later. The audio output is the difference between the output voltages developed by the two diodes D1 and D2. At the centre frequency of the circuit, this output is zero, and the output swings above or below zero as the frequency of the applied signal shifts from its centre value. We shall assume initially that the diodes have 100 per cent rectification efficiency; the audio output is then equal to the difference of the peak values of the two r.f. voltages applied to the diodes.

Now let us analyse the r.f. side of the circuit. The transformation we shall employ is that shown in Fig. 2, the development of which was given in the first part of this article. The phase-difference transformer of Fig. 1 is then identical in performance with the arrangement of three tuned circuits shown. The "ideal" transformer T serves only to ensure that the current fed to its centre tap divides equally between the branches connected to its ends. We shall concentrate initially on the two tuned circuits connected between terminals 2, 3 and 2, 4. The parameters used are $x = 2Q_s df/f_0$ and $R_s/2$, the dynamic resistance of the tuned circuits. In the expression for x , df is the shift of the signal from its centre frequency f_0 , whilst the value of Q_s is given by R_s/L_s . The centre frequency f_0 is given by $f_0 = 1/2\pi\sqrt{L_s C_s} = 1/2\pi\sqrt{L_p C_p}$. The special values of $x = \pm x_1$ give the displacement of the resonant frequencies of each of the two circuits from the centre frequency. In the circuit shown in Fig. 2, the resonant frequency of one tuned circuit is given by

$$\left(1 + \frac{M}{2L_p}\right)^{-\frac{1}{2}} f_0 \text{ and that of the other by } \left(1 - \frac{M}{2L_p}\right)^{-\frac{1}{2}} f_0.$$

These values are equal approximately to $\left(1 - \frac{M}{4L_p}\right)$

f_0 and $\left(1 + \frac{M}{4L_p}\right) f_0$ respectively, and hence

$x_1 = 2Q_s M/4L_p = Q_s M/2L_p$. This can be rearranged into a more convenient form as follows.

$$\begin{aligned} x_1 &= \frac{Q_s M}{2L_p} \\ &= \frac{Q_s k \sqrt{L_s L_p}}{2L_p} \text{ where } k \text{ is the coupling coefficient} \\ &= \frac{k Q_s}{2} \sqrt{\frac{L_s}{L_p}} \end{aligned}$$

It is shown in the Appendix that if E_p and E_s are peak values voltages across the primary and secondary winding of the phase-difference transformer at resonance, then

$$x_1 = (E_s/2)/E_p$$

With a constant-current input $I/2$ to each of the two tuned circuits connected between terminals 2, 3 and 3, 4 the difference between the peak r.f. voltages between terminals 2, 3 and 2, 4 is given by

$$E = IR_s/4(a_1 x + a_3 x^3 + a_5 x^5 \dots)$$

where

$$a_1 = 2x_1(1 + x_1^2)^{-3/2}$$

$$a_3 = x_1(2x_1^2 - 3)(1 + x_1^2)^{-7/2}$$

$$a_5 = \frac{1}{2}x_1(8x_1^4 - 40x_1^2 + 15)(1 + x_1^2)^{-11/2}$$

E is equal to the a.f. output provided that rectification efficiency is 100 per cent.

Except for the special case when the elements of the tuned circuit connected between terminals 1 and 2 become of infinite impedance, the input current, I , to the centre tap of the "ideal" transformer T is not constant. Its value can however be calculated. If the input current to terminals 1, 2 is I_{in} , then I is equal to I_{in} less the current flowing in the tuned circuit connected between terminals 1 and 2.

In order to simplify the treatment, we shall assume that the Q-values of the two circuits of the phase difference discriminator transformer are equal. Additionally, we shall employ the relationship $p = L_s/L_p$. The equivalent circuit can then be redrawn as shown in Fig. 3.

The relationship between I and I_{in} is then given by

$$I = I_{in} \frac{j + x_1^2}{\frac{j}{4} + x_1^2} \left[\frac{1 + 2x^2 \frac{(1-x_1^2)}{(1+x_1^2)^2} + x^4 \frac{1}{(1+x_1^2)^2}}{1 + 2x^2 \frac{(1-n^2)}{(1+n^2)^2} + x^4 \frac{1}{(1+n^2)^2}} \right]^{\frac{1}{2}}$$

where $n = kQ$

(see Appendix).

At first sight it would appear that the output

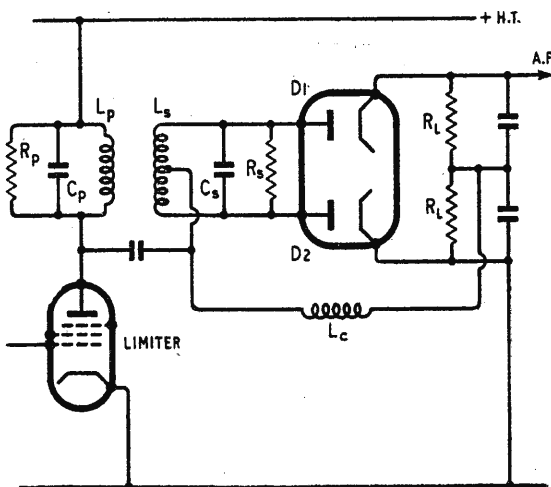

Fig. 1. Basic Foster-Seeley discriminator circuit.

for F.M. Receivers

In the first article of this series an equivalent circuit for the phase-difference transformer employed with the Foster-Seeley discriminator and the ratio detector was derived. This equivalent circuit enables these two forms of detector to be treated in the same manner as the Round-Travis circuit, already discussed, and in this part we shall discuss the Foster-Seeley circuit in greater detail.

voltage depends upon three variables, x_1 , p and n . This is however, not true because

$$x_1 = \frac{1}{2} kQ \sqrt{\frac{L_s}{L_p}} = \frac{1}{2} n\sqrt{p}$$

Thus there are only two independent variables.

From the equation for I , it will be apparent that I is independent of x only if $x_1 = n$. This is the special case referred to above, when the inductance L' becomes infinite, capacitor C' becomes zero, and R' becomes infinite. In these conditions $\sqrt{p} = 2$, and hence $I = I_{in}$ as would be expected.

It was shown in Part I that the coefficient a_3 in the expression of the output voltage is zero when $x_1 = \sqrt{1.5}$. In the phase-difference transformer, the same conditions apply when $n = \sqrt{1.5}$, and $L_s = 4L_p$.

In the general case, when x_1 does not equal n , we can express I as a power series in x , as follows

$$I = I_{in} \frac{1 + x_1^2}{\frac{p}{4} + x_1^2} (b_0 + b_2 x^2 + b_4 x^4 \dots)$$

where

$$b_0 = 1$$

$$b_2 = \frac{1 - x_1^2}{(1 + x_1^2)^2} - \frac{1 - n^2}{(1 + n^2)^2}$$

$$b_4 = \frac{2x_1^2}{(1 + x_1^2)^4} + \frac{1 - 4n^2 + n^4}{(1 + n^2)^4} \cdot \frac{1 - x_1^2}{(1 + x_1^2)^2} \cdot \frac{1 - n^2}{(1 + n^2)^2}$$

Inserting this value for I in the expression for E gives

$$E = \frac{I_{in} R_s}{4} \cdot \frac{1 + x_1^2}{\frac{p}{4} + x_1^2} (c_1 x + c_3 x^3 + c_5 x^5 \dots)$$

where

$$c_1 = (a_1 b_0)$$

$$c_3 = (a_1 b_2 + a_3 b_0)$$

$$c_5 = (a_1 b_4 + a_3 b_2 + a_5 b_0)$$

The distortion introduced is represented by the terms in x^3 and x^5 . To minimize distortion, therefore, it is desirable that the coefficients of these terms should be as small as possible. The dominant term is the coefficient of x^3 , and this can be made equal to zero by appropriate choice of parameters. For this condition, $a_1 b_2 + a_3 b_0 = 0$, and substituting values this gives

$$-x_1^2 (2x_1^2 - 3) (1 + x_1^2)^{-7/2} = 2x_1 (1 + x_1^2)^{-3/2} \times [(1 - x_1^2)(1 + x_1^2)^{-2} - (1 - n^2)(1 + n^2)^{-2}]$$

This reduces to

$$\frac{1}{(1 + x_1^2)^2} = \frac{2(n^2 - 1)}{(1 + n^2)^2}$$

The graph of x_1 plotted against n is given in Fig. 4. This shows that if n is less than 1, c_3 cannot equal zero. It also shows that if n is between 1 and 1.2 approximately, there is little margin for error in

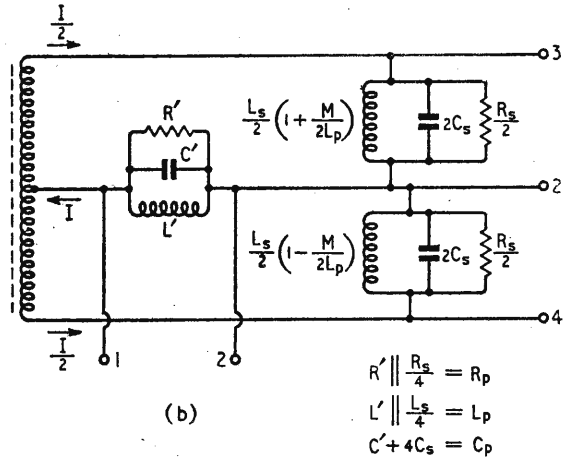
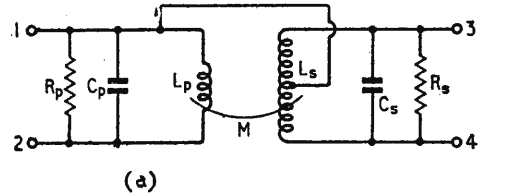

Fig. 2. (a) Phase-difference transformer, and (b) its equivalent circuit.

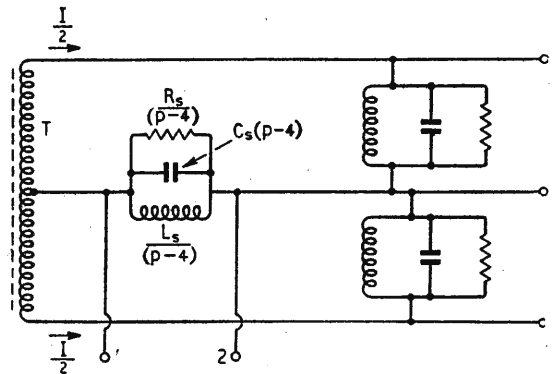

Fig. 3. Equivalent circuit of phase-difference transformer for $Q_e = Q_o$; $p = L_s/L_p$.

adjustment of n , since x_1 is varying rapidly. The minimum value of x_1 occurs when $n = \sqrt{3}$; at this value $x_1 = 1$. Above $n = \sqrt{3}$, the slope of the curve is positive. This is of some importance, since x_1 is itself proportional to n . If n departs from its correct value, it is desirable that x_1 should change in the same sense to minimize the value of c_3 .

The graph of x_1 plotted against n does not indicate any specific optimum value for n and x_1 . However,

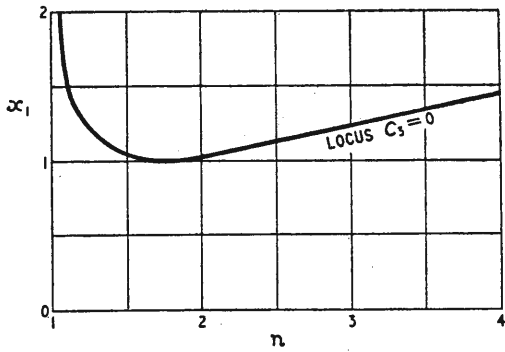

Fig. 4. Graph of x_1 against n for $c_3 = 0$.

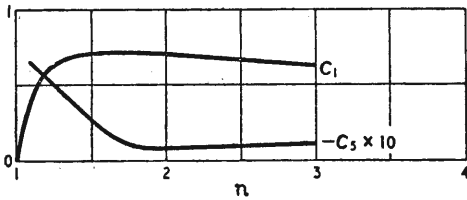

Fig. 5. Variation of c_1 and c_5 with n , for $c_3 = 0$.

this can be found by considering the coefficient of x^5 in the expansion. The value of this coefficient is plotted in the Fig. 5; at each value of n the value of x_1 is that which makes $c_3 = 0$. Additionally the graph shows the value of the coefficient of x ; minimum distortion occurs when the ratio of the coefficient of x^5 to that of x is minimum. The optimum values would appear to be near $n = 2.0$. Consider $n = 2$; in this region the coefficient of x^5 is approximately -0.008 . From Fig. 4, $x_1 = 1$ approximately. From $x_1 = \frac{1}{2} n\sqrt{p}$, $p = 1$, i.e. the two tuned circuits of the phase difference discriminator transformer are equal. From Fig. 5, the coefficient of x is 0.7 approximately.

The expression for the audio output voltage is then

$$E = 0.4 I_{in} R_s (0.7x - 0.008x^5 \dots)$$

The range of validity of this expression can be seen from Fig. 6. In this graph are two curves. Curve (a) is that obtained from the orthodox graphical solution for the Foster-Seeley response curve, which does not give any precise means of evaluating distortion; curve (b) is that derived from the expression above. It will be seen that the two curves are in very close agreement up to the value of $x = 1.4$. This then is the limit of validity of the expansion above.

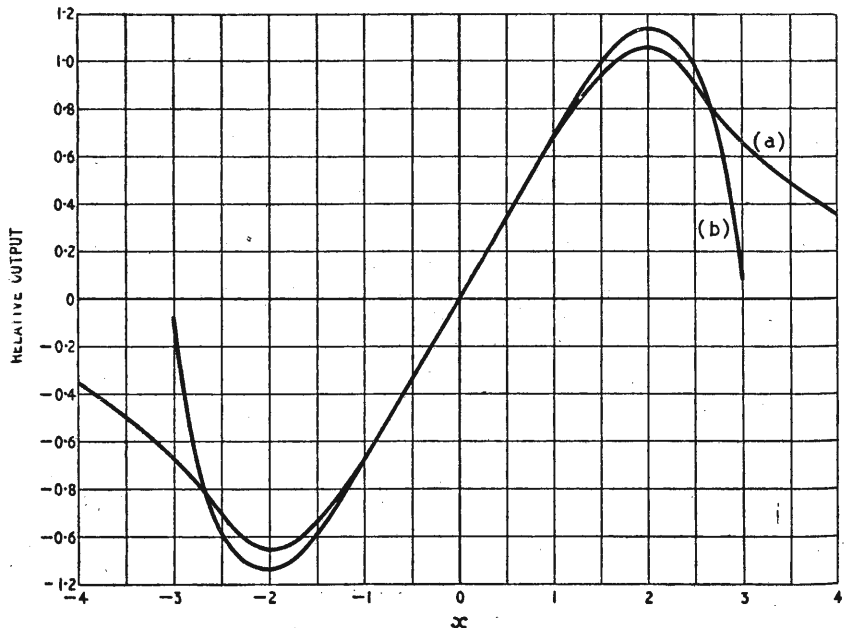

Fig. 6. Response of Foster-Seeley discriminator derived by (a) orthodox graphical solution (b) expansion given in text.

To evaluate the distortion present with the circuit constants chosen, consider an input signal $x_s \cos \omega_a t$. The a.f. output is then

$$E = 0.4 I_{in} R_s \{0.7x_s \cos \omega_a t - 0.008 (x_s \cos \omega_a t)^5\}$$

We can expand $\cos^5 \omega_a t$ by means of the identity

$$\cos^5 \theta = \frac{1}{16} \{ \cos 5 \theta + 5 \cos 3 \theta + 10 \cos \theta \}$$

giving

$$E = 0.4 I_{in} R_s \left\{ (0.7x_s - 0.005x_s^5) \cos \omega_a t - 0.0025 x_s^5 \cos 3 \omega_a t - 0.0005 x_s^5 \cos 5 \omega_a t \right\}$$

The reduction of the fundamental frequency component is negligible for the range of values of x_s of interest, i.e. $x_s < 1$. The percentage of third harmonic

distortion is thus given by $\frac{0.0025 \times 100 \times x_s^4}{0.7}$. At

$x_s = 1$, this is 0.35 per cent. By employing a smaller value of x_s , a lower value of distortion is obtained, the distortion decreasing with x_s^4 .

Consider a broadcast signal, with a deviation of 75 kc/s. If it is desired to operate the discriminator with 75 kc/s corresponding to $x_s = 1$, the parameters of the circuit are determined by $x = 2Q df/f_0$. With $df = 75$ kc/s at $x = 1$, and a centre frequency f_0 of 10.7 Mc/s, the value of Q is 71. If we assume the two tuned circuits of the phase-difference transformer each employ a tuning capacitor of 50 pF, the dynamic resistance (R_s) is 22 k Ω . The input current I_{in} is the peak value of the fundamental frequency component in the output of the preceding limiter stage; a typical value is 1 mA. The peak audio output is given by $0.28 I_{in} R_s$, and in this example is 6.2 volts approximately.

It can be seen, from the expression for E , that the audio output is proportional to $I_{in} x$, where I_{in} is the input current, and x is a measure of the frequency

(Continued on page 73)

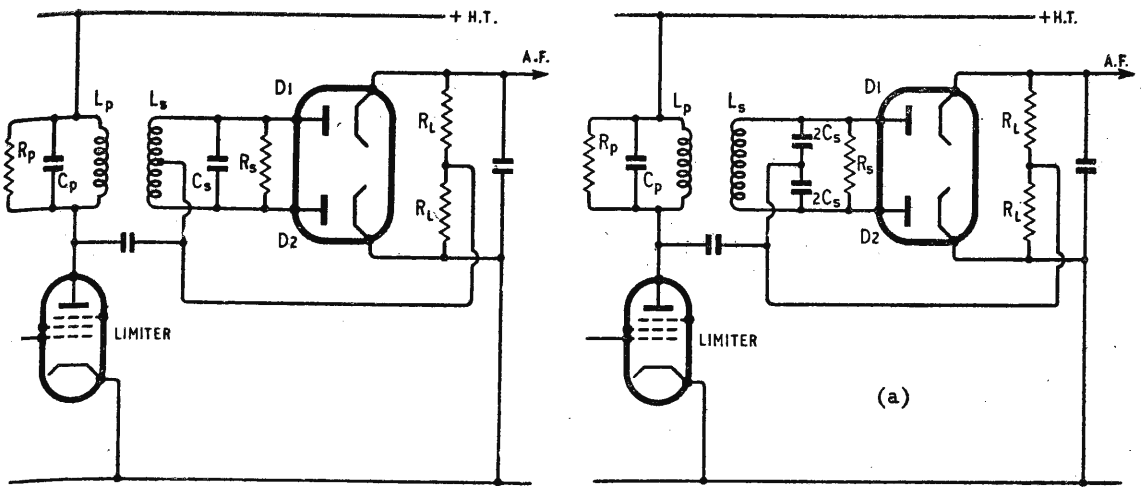

Fig. 7. Alternative form of Foster-Seeley discriminator.

shift. If there is amplitude modulation present, the magnitude of I_{in} varies, but if $x = 0$, i.e. the signal is at the centre frequency there is no output due to a.m. For any other value of x , i.e. if the signal is mistuned or frequency-modulated, there is an output due to the amplitude modulation. Because the output is proportional to $I_{in}x$, the a.m. and f.m. signals are multiplied together and there is complete cross-modulation. Thus a Foster-Seeley discriminator must be preceded by a limiter stage.

To complete the survey of the Foster-Seeley circuit, there are a number of practical points to be considered. The first of these concerns the diode load resistors. These should not be too large, as otherwise "diagonal clipping" can occur. Briefly this happens if the input to one diode falls rapidly. If the time constant of the load circuit is too great, the cathode potential cannot fall sufficiently quickly, and the diode may be cut off. For this reason, the diode load resistors are usually limited to 100 k Ω , and the shunt capacitors to 50 pF.

This relatively low value of diode load in turn means that the damping imposed in the tuned circuits cannot be neglected. The input resistance of each diode at r.f. is $R_L/2\eta$, where R_L is its load resistance and η is the rectification efficiency. In the equivalent circuit of Fig. 3, the relationship between the resistances of the two tuned circuits connected between terminals 2, 3 and 2, 4 and that connected between terminals 1, 2 then differs from that postulated. The condition can, however, be re-established if an additional resistor equal to $R_L/(p-4)$ is connected between terminals 1 and 2, i.e. across the primary winding of the original circuit. However, the values of p employed in practice are often less than 4, implying that a negative resistance is required. This obviously cannot be realised in practice. It suggests, however, that the Q values can be equalized if the secondary Q value without the diodes connected is lower than the primary Q value. Given equal initial Q values, a

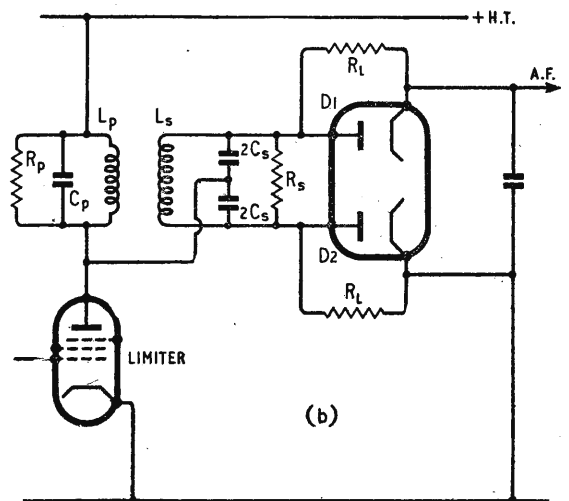
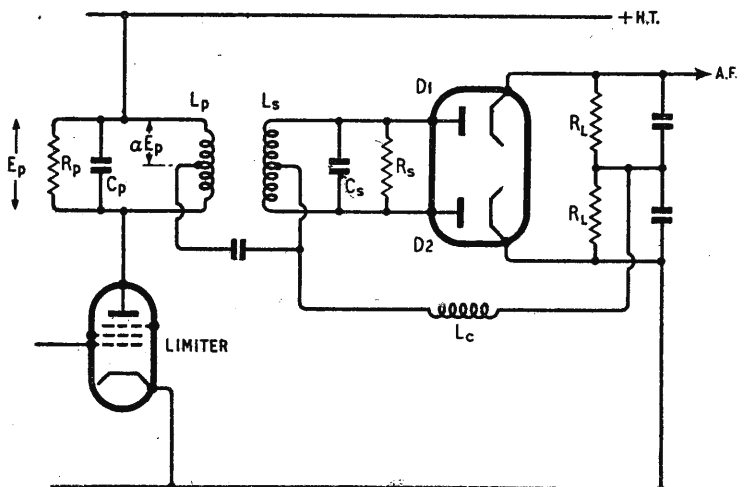

Fig. 8. Further alternative forms of Foster-Seeley circuit, with the secondary circuit centre taps produced by the capacitors.

Fig. 9. Foster-Seeley discriminator with tapped primary circuit.



resistor can be connected in parallel with the secondary circuit to achieve this result. Its value can be calculated if it is remembered that the damping imposed on the primary circuit is $R_L/4\eta$, whilst that imposed on the secondary circuit is R_L/η . In the example considered above, with equal primary and secondary circuit, the resistance would be $R_L/3\eta$.

It is common practice to omit the r.f. choke L_c shown in Fig. 1, giving the circuit of Fig. 7. In this case it must be remembered that there is then additional damping equal to $R_L/2$ imposed on the primary circuit, since the primary circuit can "see" the two resistors R_L in parallel.

An alternative form of Foster-Seeley circuit is that shown in Figs. 8(a) and 8(b). In the arrangement, the secondary centre-tap is provided by the capacitors. Because there is no longer d.c. continuity for the diodes of Fig. 8(b), the diodes are shunt-fed. The damping imposed on the secondary circuit is the R_L/η in parallel with $2R_L$, whilst that

on the primary is $R_L/4\eta$ in parallel with $R_L/2$. In one other variant the primary as well as the secondary is tapped, as shown in Fig. 9. If the ratio of voltage tapped off to the total primary voltage is a , then this circuit can be analysed by replacing the primary circuit by a single un-tapped circuit, with parameters as follows:

$$\begin{aligned} L'_p &= L_p a^2 & E'_p &= a E_p \\ C'_p &= C_p / a^2 & M' &= M a \\ R'_p &= R_p a^2 & k' &= k \\ I' &= I/a & Q' &= Q \end{aligned}$$

This circuit has one particular advantage. If $a = \frac{1}{2}$, i.e. the primary circuit is centre-tapped, the damping applied to primary and secondary circuits by the diode loads is automatically equalized. In such a circuit, the value of p in the equivalent circuit is equal to 4, i.e. the analysis simplifies to the case, when the tuned circuit in parallel with the input terminals vanishes. For this condition of operation, the optimum value of $n = \sqrt{1.5}$.

APPENDIX

The equivalent diagram for two circuits coupled by mutual inductance is shown below. The circuit equations are

$$\begin{aligned} E_s &= jX_{cs}i_s \\ E_p &= jX_{cp}i_p - j\omega M i_s \\ 0 &= Z_p i_p - j\omega M i_s - jX_{cp}i_p \\ 0 &= Z_s i_s - j\omega M i_p \end{aligned}$$

where $X_{cs} = 1/\omega C_s$
 $X_{cp} = 1/\omega C_p$

$$Z_p = jL_p\omega + \frac{1}{j\omega C_p} + r_p$$

$$Z_s = jL_s\omega + \frac{1}{j\omega C_s} + r_s$$

In the region near the resonant frequency (f_0) of the two circuits, $i_p \gg i_s$. Then

$$E_s = -jX_{cp}X_{cs} \frac{\omega M}{Z_p Z_s + \omega^2 M^2} i$$

$$E_p = X_{cp}^2 \frac{Z_s}{Z_p Z_s + \omega^2 M^2} i$$

Near resonance $\omega L_s - 1/\omega C_s$ is approximately equal to $2L_s\delta\omega$, where $\delta\omega$ is the departure from $\omega_0 = 2\pi f_0$. Similarly, $\omega L_p - 1/\omega C_p = 2L_p\delta\omega$. This gives

$$E_s = jX_{cp}X_{cs} \frac{\omega M}{(r_p + 2jL_p\delta\omega)(r_s + 2jL_s\delta\omega) + \omega^2 M^2} i$$

$$E_p = X_{cp}^2 \frac{r_s + 2jL_s\delta\omega}{(r_p + 2jL_p\delta\omega)(r_s + 2jL_s\delta\omega) + \omega^2 M^2} i$$

Let

$$\frac{L_p\omega_0}{r_p} = \frac{X_{cp}}{r_p} = Q_p; \quad \frac{L_s\omega_0}{r_s} = \frac{X_{cs}}{r_s} = Q_s; \quad y = 2\frac{\delta\omega}{\omega_0} = 2\frac{\delta f}{f_0}$$

and $n = k\sqrt{Q_p Q_s}$ where $k = M/\sqrt{L_p L_s}$

$$E_s = \frac{-jQ_p X_{cp}}{(1 + jQ_p y)(1 + jQ_s y) + n^2} \cdot kQ_s \sqrt{L_s/L_p} i$$

$$E_p = \frac{Q_p X_{cp}}{(1 + jQ_p y)(1 + jQ_s y) + n^2} \cdot (1 + jQ_s y) i$$

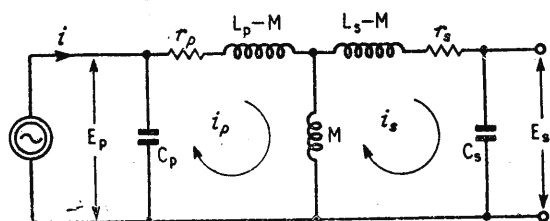

whence $E_s = \frac{-j k Q_s \sqrt{L_s/L_p}}{1 + jQ_s y} E_p$

let $p = L_s/L_p$, and $y = 0$, i.e., the circuits are at the resonant frequency. Then if $|E_s|$ is the magnitude of E_s , and $|E_p|$ is the magnitude of E_p ,

$$\frac{1}{2} k Q_s \sqrt{p} = (|E_s|/2)/|E_p|$$

Finally if $Q_p = Q_s$, $Q_p X_{cp} = R_p$, and $Q_y = \frac{2Q\delta\omega}{\omega_0} = x$

$$E_p = \frac{R_p(1 + jx)}{(1 + jx)^2 + n^2} i$$

In the equivalent circuit discussed in the text, this voltage is that applied to the tuned circuit connected between terminals 1 and 2 when $i = I_{in}$. In the text $p = L_s/L_p = R_s/R_p = C_p/C_s$. Thus the tuned circuit between terminals 1 and 2 consists of three branches in parallel; (a) inductor $L_s/(p-4)$; (b) capacitor $(p-4)C_s$; (c) resistor $R_s/(p-4)$ (see fig. 3). Then the current I' flowing into the three elements is given by

$$I' = E_p Y$$

where $Y = \frac{(p-4)/j\omega L_s + j\omega C_s(p-4) + (p-4)/R_s}{(1/j\omega L_s + j\omega C_s + 1/R_s)(p-4)}$

$$= \frac{p-4}{R_s} (1 + jx)$$

Thus $I' = \frac{R_p(1 + jx)}{(1 + jx)^2 + n^2} \cdot \frac{p-4}{R_s} (1 + jx) I_{in}$

$$= \frac{p-4}{p} \frac{(1 + jx)^2}{(1 + jx)^2 + n^2} I_{in}$$

But the current I fed to the centre-tap of transformer T is equal to $I_{in} - I'$. Hence

$$I = I_{in} \left\{ 1 - \frac{p-4}{p} \frac{(1 + jx)^2}{(1 + jx)^2 + n^2} \right\}$$

$$= I_{in} \frac{pn^2 + 4(1 + jx)^2}{pn^2 + p(1 + jx)^2}$$

$$= I_{in} \frac{4x_1^2 + (1 + jx)^2}{p \cdot n^2 + (1 + jx)^2}$$

$$= I_{in} \frac{1 + x_1^2}{\frac{p}{4} + x_1^2} \cdot \frac{1 - x^2/(1 + x_1^2) + 2jx/(1 + x_1^2)}{1 - x^2/(1 + n^2) + 2jx/(1 + n^2)}$$

If $|I|$ is the magnitude of I and $|I_{in}|$ that of I_{in} then

$$|I| = |I_{in}| \frac{1 + x_1^2}{\frac{p}{4} + x_1^2} \left\{ \frac{1 + 2x^2(1 - x_1^2)/(1 + x_1^2)^2 + 2jx/(1 + x_1^2)}{1 + 2x^2(1 - n^2)/(1 + n^2)^2 + 2jx/(1 + n^2)} \right\}^{\frac{1}{2}} \cdot \frac{x^4/(1 + x_1^2)^2}{x^4/(1 + n^2)^2}$$

In the absence of a really cheap and simple colour display device for domestic receivers—on which the success of colour television so much depends—it may be considered somewhat profitless to discuss the question of transmission systems. There is, however, one point of view which should be heard. This argues that the system should not be tailored to fit the display device (as with the N.T.S.C. system and the three-gun shadow-mask c.r.t.) but should be made as perfect as possible in the expectation that display and receiving equipment will eventually be developed to match it. Such is the theme of this article.

N.T.S.C. Colour Information

Where the System Fails Through Expediency

By E. L. C. WHITE,* M.A., Ph.D., M.I.E.E.

FROM the vast body of work that has been done on colour television in the last few years a number of principles have emerged which now find very wide acceptance.

First is the idea of "compatibility." This means that the colour signals must be sufficiently similar in form to existing monochrome standards to give good black-and-white pictures, with no untoward effects, on monochrome receivers of normal design. Thus colour can be added to selected programmes, and the proportion increased as warranted by the increasing numbers of colour receivers.

Secondly, it has been recognized that a compatible system can be achieved by rearranging the primary red, green and blue signals into three other signals, one of which is representative of the brightness and therefore contains some of each of red, green and blue in suitable proportions. This brightness signal has the synchronizing pulses added to it, and is all that is needed for monochrome receivers.

The third principle is that the other two signals should only carry the colour information, as distinct from the brightness, and need only have a bandwidth which is a fraction of that of the brightness, or "luminance," signal.

Fourthly, there is the technique of adding the narrow-band colour signals, in the form of modulated sub-carriers, to the brightness signal within its normal frequency band. By adopting special frequency and phase relationships of the sub-carrier relative to the line scan, the objectionable effects of dot pattern on monochrome receivers and loss of detail resolution on colour receivers can be minimized. This technique has been, and still is, the subject of much controversy. In spite of its drawbacks, it will probably have to be accepted because of the scarcity of bandwidth in the radio-frequency spectrum available to television.

The fifth principle is the method of carrying the colour information, consisting essentially of two independent variables, on a single sub-carrier, by simultaneous phase and amplitude modulation. This is the subject which will be discussed here, with particular emphasis on the exact nature of the information carried.

As the N.T.S.C. system is now generally well

known, it is a useful standard of comparison. Its salient features have already been discussed in *Wireless World*† but a short recapitulation of some of the relevant points will be useful here.

At the transmitting end, the primary red, green and blue signals from the camera, after individual gamma correction, are applied to proportional adding circuits to form three other signals E_Y' , E_I' and E_Q' . (Here the tick indicates that the signals are not linear but are formed from gamma-corrected primaries. This gamma correction is to compensate for the non-linear light output characteristic of the receiver c.r.t., which usually follows a power law, so that the correction has to be an inverse power law). E_Y' is the luminance signal already mentioned, while E_I' and E_Q' are known as "chrominance" signals.

E_I' and E_Q' are used to modulate two orthogonal phases of a sub-carrier. Its frequency is an odd multiple of half the line scan frequency, to give dot interlace. The final output, which also includes sync pulses and a colour sync "burst," is formed by adding to E_Y' the modulated sub-carrier. The signals are band limited in varying degrees, on principles already discussed in the previous *Wireless World* articles.

The Colour Sub-Carrier

An important feature of the system is that the vector diagram of the colour signal is very similar in form to the standard chromaticity diagram (the international reference frame for colour specification), with the origin shifted to white. This is shown in Fig. 1, where the sub-carrier vector is superimposed on the chromaticity diagram‡. Hue becomes related to phase, and saturation to amplitude, and for white the sub-carrier has zero amplitude.

Another feature, and one which is not always realized, is that the amplitude of the colour signal is not dependent only on saturation, but also on

*E.M.I. Electronics, Research Division. This article is based on a lecture given recently by the author to the Television Society.

†See "American Colour Television," Nov 1953, "Colour Television Standards" and "Transmitting Colour Information," Aug. 1955.

‡For an explanation of chromaticity and the chromaticity diagram see "Colour Fundamentals" in the Aug. 1956, issue, p.363.

brightness. This is a notable departure from the third principle enumerated above, and is, in fact, the main reason why the nature of the colour information transmitted by the N.T.S.C. system is open to question.

According to simple philosophy, the information should be pure chromaticity. This means dominant wavelength (or hue) and purity (or saturation), and corresponds to the familiar concept of colour quality, as distinct from quantity of light. This chromaticity information can be given, for example, by the x and y co-ordinates in Fig. 1, or suitable linear transformations of them. These are essentially functions of ratios, as already explained in *Wireless World*,[†] and are independent of brightness.

The signals transmitted by the N.T.S.C. system, however, are not truly representative of chromaticity. They are "colour-difference" signals, as mentioned in previous articles[†] and have been given the name "chrominance" by the N.T.S.C. to distinguish them from the idea of pure chromaticity.

There is another way in which the N.T.S.C. system departs from straightforward principles. This arises from the process of gamma correction. As already mentioned, the transmission system corrects for the non-linear electron-gun characteristics, or gamma, of the three-gun picture tube by interposing stages with an inverse power law between the linear signal sources and the proportional adding circuits.

From the short view, the reason is sound enough, as the alternative is to put the gamma correction immediately before the picture tube, which is uneconomical because it would be necessary in every receiver. However, the technique has several disadvantages, especially near saturated colours, and these are: (1) loss of luminance detail; (2) the system is no longer "constant-luminance," i.e. noise and interference in the sub-carrier band will produce brightness fluctuations as well as colour variations; (3) there is a non-linear relationship between the sub-carrier signal and the reproduced chromaticity,

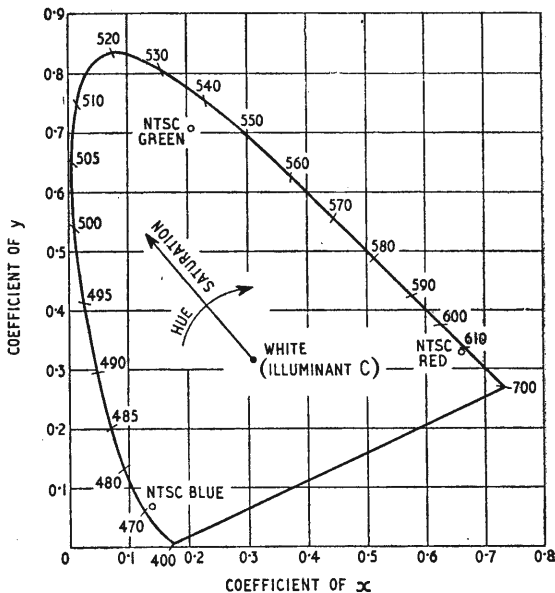

Fig. 1. Standard chromaticity diagram, with spectrum wavelengths in millimicrons and N.T.S.C. primaries. The vector representing the colour sub-carrier is superimposed to show its relationship.

which, for example, renders the hue near the complementary colours much more critical with regard to sub-carrier phase inaccuracy than is that near the primary colours.

Fig. 2 shows how the loss of luminance detail arises near saturated colours. Gamma is taken to be 2.0—that is, a square-law characteristic. The effect of the narrow-band chrominance circuits on a step waveform is simplified by showing the output as a ramp function.

For a transition from red to blue at constant luminance, it will be seen that the square-law effect of the three-gun display-tube causes a dip in the displayed luminance. More striking, perhaps, is the blurring of the edge in a transition from dark blue to light blue. This is not due to the non-linearity, but to the fact that the colour signal is chrominance or colour-difference rather than chromaticity or colour ratio. Thus the major portion of the brightness change is carried over the narrow-band chrominance signal.

American Modifications

The solution to all these problems is to send a pure chromaticity signal for the colour information, but first some palliatives suggested by the N.T.S.C. will be mentioned.

The first arrangement entails a correction to the transmitted signal which removes the loss-of-detail fault shown at the bottom of Fig. 2. Unfortunately this leads to poor compatibility since the correction is not required by monochrome receivers, and on these the edges would be unnaturally emphasized.

The next step considered by the N.T.S.C. was to see what could be done at the cost of introducing one non-linear circuit in a three-gun receiver. This also modified only the luminance signal. It has the advantage of being correct for monochrome receivers, but still gives non-linear colour-difference signals on the sub-carrier.

Finally, schemes were considered in which more than one non-linear circuit might be required in an ideal receiver. This led to the use of a true luminance signal, as mentioned above, and a linear type of colour signal. Three possibilities were considered.

In the first, the chromaticity information was to be transmitted linearly in terms of the sub-carrier amplitude. Because of possible objection to a large sub-carrier amplitude at low brightness levels (giving, for example, reduction of contrast on monochrome receivers) a second alternative was discussed in which a linear chrominance signal was to be used. Besides being no longer a ratio type of system, this went to the other extreme, and the N.T.S.C. favoured a compromise in which chromaticity multiplied by a gamma-corrected luminance signal was used.

In general the receiving equipment required to take advantage of these modifications is either somewhat complex and expensive, or, if simplified, has a tendency to introduce new faults, such as errors in brightness and hue.

From the above discussion, then, it emerges that the N.T.S.C. system, as at present practised, is tailored to give good large-area colour rendering on a three-gun type of tube driven from a receiver having no intentionally non-linear circuits, and that, nevertheless, the system has a number of failings which are probably more easily observed than colour inaccuracies would be.

While it is essential to aim at a low-cost receiver—the absence of which is at present the main brake on the development of colour television—it may be questioned whether in the long run the three-gun tube is the best basis for this. Not only do three guns add to the expense of manufacture, but they bring with them all the problems of registration, which are by no means solved in existing designs, and necessitate two extra wideband video output stages capable of providing about 100 volts swing and a stable black level.

Fundamentally what is required is a single electron gun controlled by a brightness signal, and a screen consisting of a mosaic of differently coloured phosphor dots or strips, with some mechanism which ensures that the spot only excites appropriately coloured dots or strips depending on the colour signal.

Two types of single-gun tube have been successfully demonstrated using this broad principle. One is the Chromatron, or "Lawrence" tube, using a beam deflecting grid near the screen (see July, 1953, issue, p. 329) and the other is the Philco beam-indexing tube, in which the colour signal is applied to the gun in accordance with the position of the beam across the phosphor strips (see January, 1957, issue, p. 2). Both of these tubes have been used on the N.T.S.C. system. The receivers have needed somewhat greater complexity than those for the three-gun tube, but this is largely due to the N.T.S.C. system being tailored to suit the last-mentioned.

Consider the basic requirements of these single-gun tubes, in which the beam excites the three primary phosphors sequentially and the colour is controlled by gating the beam on and off at appropriate times. For peak-white the brightness signal is a maximum, and it is reasonable to adjust the phosphor efficiencies so that the desired reference white (e.g., Illuminant C on Fig. 1) is obtained when each phosphor is equally excited. The symmetry of this arrangement necessitates a brightness signal which is

$$\text{given by } E_B = \frac{E_R + E_G + E_B}{3}. \text{ The symbol } E_B$$

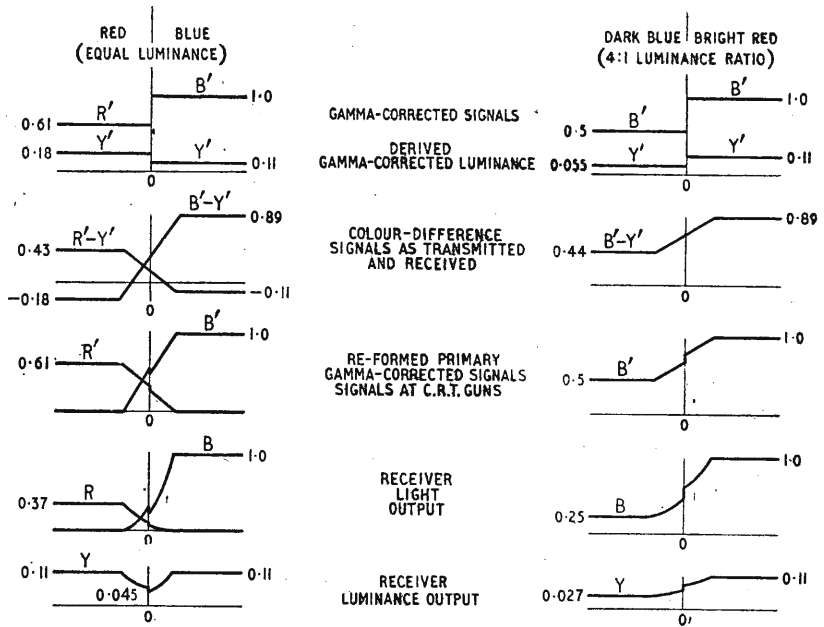
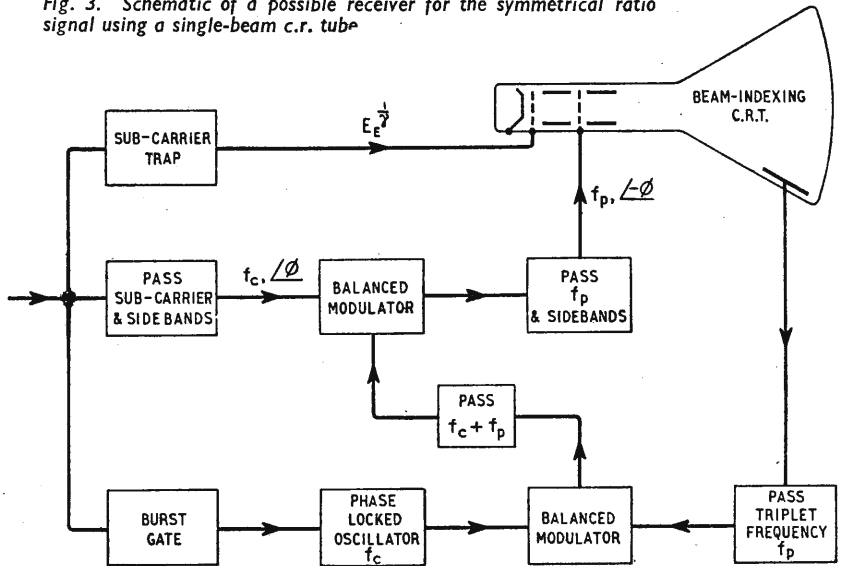

Fig. 2. Illustration of how gamma-correction causes loss of luminance detail near saturated colours. Read from top (transmitting end) to bottom (receiving end).

Fig. 3. Schematic of a possible receiver for the symmetrical ratio signal using a single-beam c.r. tube



is used because this "brightness" corresponds more to total energy than to total luminosity. The signal E_B is preferably gamma-corrected at the transmitter for the receiver electron-gun characteristic, and is transmitted instead of the signal E_Y' in the N.T.S.C. system.

To accompany this "symmetrical" brightness signal, a symmetrical colour signal is also required at the receiver. Such a signal could consist of a sub-carrier modulated in three different phases 120° apart by the three linear colour components E_R , E_G and E_B .

If the tube has a single beam control electrode, as in the existing Philco beam-indexing tube, then the colour signals, if they are to be used with the

Technical Notebook

Single-Pentode Flip-Flop, devised by T. E. Ivall, operates by using the valve as a pair of triodes connected in series—the bottom one acting as a cathode follower. A negative trigger pulse applied to the suppressor drives the anode, and hence the control grid, positive. Current is drawn through the screen grid, the cathode also goes positive, and, by virtue of the increased current through the cathode resistor, the suppressor is driven even more negative. A rapid cumulative action takes place, cutting off the top “triode” and rendering the bottom one fully conducting. A positive-going trigger pulse reverses the action. Because of the complete 360° phase shift round the loop the

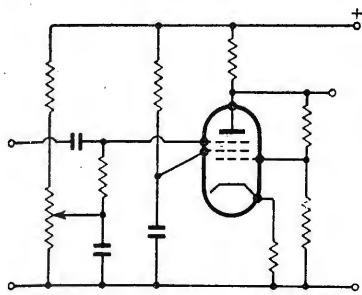

circuit can be operated as a sinusoidal oscillator with, say, an LC circuit in place of the anode load, or a simple RC combination in place of the potential divider connecting anode to grid. A valve with a short suppressor grid base (such as the old EF50) is the most suitable type.

Bilingual Television Transmission, with two different sound accompaniments to the picture, may be a desirable thing for some countries. A method of achieving this technically, devised by the French firm Radio-Technique, has been reported by the European Broadcasting Union. The two audio signals are arranged to amplitude modulate two interlaced trains of pulses transmitted in the normal sound channel—on the time-division multiplex principle. The time spacing of the pulses in each train is equal to the duration of a line scan, and the trains are phase locked to the line sync pulses. At the receiving end the method of separation is to apply a gating signal to one of the sound-channel i.f. valves in such a way that only the pulses carrying the wanted sound accompaniment are allowed through. The gating signal is generated by shock exciting an oscillator circuit (tuned to the line frequency) from the line scanning circuits and then limiting the resultant complex waveform to provide the required gating voltage levels. By simply reversing the excitation leads either one or the

other of the sound accompaniments is gated as required. It is claimed that a very simple and inexpensive “decoder” unit, using no valves, is all that is required to change an ordinary television set into a “bilingual” receiver.

Binary Coded Scales are now being used on electronically controlled machine tools and other equipment where it is necessary to measure a mechanical displacement with great accuracy. They convert the analogue type of indication, such as a pointer against a scale, into a series of digits which can be read off quickly so that the task of the human operator is greatly eased. The circular scale in the sketch (made by Hilger & Watts) is for indicating angular displacement in binary digital form. The binary scale is more economical in displacement detection than other scales (e.g., 0 to 9 in decimal re-

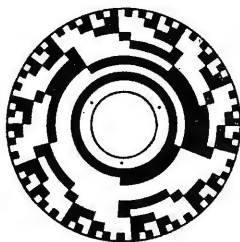

quires ten elements compared with four in binary) and because there are only “0” and “1” elements involved it is easy to devise electrical pick-off systems for feeding the information into digital computers or other electronic data processing equipment. As well as the pure binary code, it is possible to use binary-coded decimal and other special arrangements.

“Too Old At—?” in our September, 1956, issue certainly revealed some interesting facts about people’s hearing, but it didn’t tell you at what stage of development or decay you have to be to hear electrical signals direct without an acoustic transducer. According to a report in the October, 1956, issue of *Proc. I.R.E.*, engineers have experienced an audible response when standing six

feet away from the horn of a radar set working at 1300 Mc/s with a peak power of half a megawatt. The pulse length was 2μsec and the p.r.f. was 600 c/s. The most sensitive part of the head proved to be at the sides at a point midway between the ears and eyes and slightly above them. The sounds heard were mostly high-frequency components without much of the 600-c/s fundamental, and people whose ear responses cut off at 5 kc/s heard them much less strongly than those who went up to 15 kc/s. A deaf man with a bone-conduction hearing-aid heard nothing at all. Unfortunately, such experiments can be dangerous because high-power microwave radiation can produce cataracts of the eye.

Aluminium-Wire Speech Coils, used in loudspeakers to reduce the mass of the vibrating system, bring with them the problem of soldering the wire ends. Wharfedale Wireless Works, in collaboration with Mullard, have solved the problem by dipping the wires into a small bath of molten solder agitated by ultrasonic energy. A cavitation effect in the solder removes the oxide film from the aluminium and effective tinning is achieved. Afterwards the tinned wires can be soldered in the ordinary way. A solder compound of 90 per cent tin and 10 per cent zinc is used in the bath at a temperature of about 230°C and the tinning operation takes 2-3 seconds. A recent improvement to the technique



has been a simplified method of maintaining the ultrasonic energy at the optimum frequency to ensure maximum soldering efficiency under all conditions.

Simple Linearity Control for television line scanning, devised by J. C. MacKellar and K. E. Martin of Mullard, consists of short-circuited turns made of foil underneath the line scanning coils on the c.r. tube neck. During scanning the e.m.f. induced in the short-circuited turns is proportional to the rate-of-change of scanning flux. It causes a current to flow which, because of the R and L of the turns, changes exponentially. The flux produced by this induced current opposes the scanning flux and, if the time constant of the turns is small compared with that of the generating circuit, the waveform of the correcting flux is

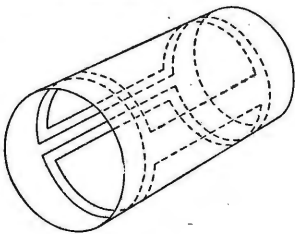

more curved than that of the scanning flux. Thus the curved sections of the waveforms can be arranged to roughly match each other so that a substantially linear scan is obtained with very little decrease in amplitude. Adjustment of linearity is achieved by moving the short-circuited turns in relation to the scanning coils so that the flux linkage, and hence current induced, is varied. No "ringing" is caused, as with other types of linearity control. The sketch shows how a pair of the short-circuited turns can be constructed. They are actually joined at adjacent edges as this simplifies manufacture to producing one foil stamping instead of two. Non-linearity can be reduced to less than 5% and the efficiency compares favourably with existing types of control.

Efficient Rectifier Cooling is the reason for the unusual "mouth-organ" construction of the new Siemens & Halske selenium h.t. rectifiers recently shown to us by R. H. Cole (Overseas). The plates are held at the edges and are arranged in groups with spaces between to give a series of "chimneys" for convection cooling. Then the edge-mounting gives a direct conduction cooling for each set of plates on to the aluminium case, which, in turn, is contact-cooled when it is held flat against a chassis by the fixing lugs. This edge-mounting of the plates has a distinct advantage over the more conven-

tional contact-cooled rectifiers, where the plates are stacked parallel with the case side, since it cools all of the

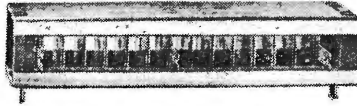

plates equally instead of just those at the outsides. The rectifier illustrated is a 220-V 300-mA type and measures only $3\frac{1}{8}$ in \times $1\frac{1}{4}$ in \times $\frac{1}{4}$ in.

Simple Transistor Testing, using d.c. methods, may not give complete and detailed information, but it can still be useful in providing a general indication of characteristics. With this in mind, Mullard have introduced a simple instrument by which it is possible to check three of the more important junction transistor parameters, and the measurements are presented as direct meter readings. For the first parameter, base-collector short-circuit current gain, advantage is taken of the approximately linear relationship between collector current and base current. This permits finite changes of current to be used to measure the parameter with an accuracy high enough for all practical purposes. Measurement is thus reduced to observing the collector current produced by a convenient known base current and transcribing it into a direct meter reading of base-collector current gain. The second parameter is the d.c. collector current for zero base current. Here, since the d.c. collector current is sensibly independent of collector voltage, direct metering of this parameter can be made. Finally, for collector turnover voltage, the tester measures the collector-emitter turnover voltage for zero base current. A relatively high voltage is applied to the collector via a resistance, and the turnover voltage is read directly from the meter.

Aluminium Soft-Soldering, normally very difficult because of the tenacious oxide film which prevents "wetting" of the metal surface, should be made much easier by a special tool introduced by the Belark Tool and Stamping Company. With this, the surface of the aluminium is mechanically cleaned by a small steel-wire brush vibrating at 100c/s in the centre of the soldering bit (see illustration). Re-oxidization is

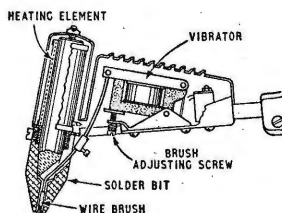

prevented by working with a pool of molten solder round the bit which excludes the air while tinning is taking place. No flux is used, but the solder has to be the special blowpipe type (80% tin and 20% zinc) with a melting point of 220°C. The soldering bit is actually heated to approximately 500°C, and this is sufficient for soldering sheet metal up to 12 s.w.g. thickness and small castings. Two pieces of aluminium which have been tinned with this vibratory tool can afterwards be joined together by orthodox soldering methods.

Wider than Wide-Angle television c.r. tube recently introduced by RCA in America makes one wonder if the flat "picture-on-the-wall" display device will really be necessary after all. The tube is a 21-inch rectangular type (21EP4) and has a diagonal deflection angle as large as 110° (or a line scan angle of 106°, as shown)! This has reduced the overall length by about 5½ inches over comparable tubes with the same size of screen and 90° deflection angles. Another feature is a narrow neck diameter (1¼in), which makes

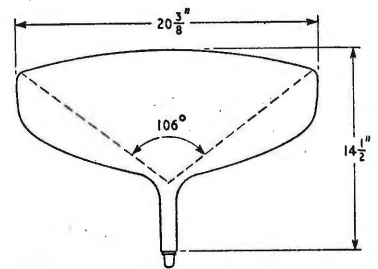

it possible to deflect the beam through the extra wide angle with only slightly more power than is required to scan a tube with a 90° angle. An electrostatic focusing system is incorporated for maintaining uniformity of focus over the whole screen. Other American tube manufacturers are following suit with the new angle.

Printed Magnetic-Cell storage device for holding binary information has recently been developed by RCA. An experimental unit has a capacity of 2,560 bits in a volume of only 2 cubic inches. It works on the magnetic-cell matrix principle described in the December, 1956, issue (p. 596) but consists of a series of thin plates of ferromagnetic material with printed conductors joining the holes. This is possible because the ferromagnetic storage medium is a ceramic-type material and therefore an insulator. The idea offers a great simplification in manufacture over the conventional matrix stores in which a complex pattern of wires has to be threaded through a great many tiny ferrite cores.

LETTERS TO THE EDITOR

The Editor does not necessarily endorse the opinions expressed by his correspondents

Transistor Symbols

I HESITATE to add yet another transistor symbol to the great scrap-heap of suggestions that has accumulated already, but I think H. J. Cooke (December, 1956, issue) is working in the right direction and a simplification of his ideas might be worth considering. The following criticisms come to mind:

(1) The point transistor is practically finished, so why bother about it? Even its negative resistance characteristic, so useful for switching, can now be produced in junction devices.

(2) The graphical distinction between $p-n-p$ and $n-p-n$ junction types is not really essential, since this is usually obvious from the polarity of the transistor's power supply.

(3) Anything which involves rectangles or triangles, especially blacked-in ones, takes time to draw. (The ultimate choice of symbol will almost certainly be influenced by technicians who have to sketch it rapidly on the backs of old envelopes.) In any case, enclosed areas do not capture the interest of the eye and suggest function so effectively as the active line.

(4) Mr. Cooke's arrow for identifying the emitter of the junction transistors suggests that this arrow is in itself the emitter—whereas in reality the emitter is the left-hand junction between n - and p -type materials indicated by the adjoining rectangles in his drawing. Here again we have an element of redundancy and possible confusion.

A logical outcome of these criticisms would be a symbol something like that in the accompanying sketch. I am not particularly fond of it, but at least it is simple and has a familiar look about it without suggesting the physical construction of the point transistor.

London, S.E.5.

JAMES FRANKLIN.

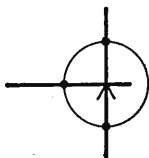

Transistor Chaos

"CATHODE RAY" (November-December, 1956, issues) would find transistor symbols almost as chaotic here as in Britain. However, I would recommend to him the adoption of β for the common emitter current gain, since it is already used by the majority of American manufacturers. The symbol α can then be allowed to waste away.

Which of the resistor systems should be adopted is seemingly being decided by ease of measurement. No doubt this simplifies the work of the quality control section, but surely more emphasis should be placed on the easing of circuit design. The great advantage of the r_b, r_c, r_e system is that external impedances can often be added in directly. With the other systems the external values must be inserted in equations which often obscure the relative importance of the various components.

Canadian Westinghouse Company,
Hamilton, Ontario.

M. O. FELIX.

"High-Quality" Demonstrations

WHILE I agree with Mr. H. Glover (October issue) that the electronic organs are of limited value as test material for high-quality sound systems, I feel that he has overlooked one of their most important features.

It is well known that those organs produce low pedal

notes. This makes them particularly useful for demonstrating the bass capabilities of a loudspeaker. In particular the records of Lenny Dee, which a number of demonstrators used, have excellent pedal notes.

A larger than usual cone area seems necessary for their reproduction, and anything less than an 18-in unit or, say, two 12-in units in a suitable enclosure would appear to be inadequate.

Crowborough.

E. R. ASLIN.

Spare Parts

THE increasing complexity of the modern television and sound broadcast receiver prompts me to ask whether the time is not fast approaching when the manufacturers should, in fairness to the buyers of their products, be willing to supply spare parts directly to the private customer in the cases where he is willing and able to fit them.

I have been employed in the radio industry for over 21 years and I well know the arguments against supplying the general public with spares. These, I submit, were perfectly valid in the days when the dealers required only a reasonable ability as repairers and when circuits were simpler. Also, in those far-off happy days the general public knew very little of radio servicing and possibly cared less.

The position today is entirely different. There are now literally hundreds of firms employing radio "technicians"—for want of a better term—whose daily work involves far more ability than required to repair a radio receiver of half-a-dozen valves.

On the other side, there is reputed to be a shortage of 50,000 service technicians in the retail-radio trade. This simply means that having paid possibly £100 for a television receiver, the customer is unable to obtain efficient servicing if and when it breaks down.

I would, therefore, respectfully suggest, sir, that there is a case for the manufacturers to supply parts at normal prices to anyone wishing to buy, provided he quotes the serial number of his receiver. This would prevent spare-time repairers stealing too much business from the dealers, some of whom show at times a lamentable lack of enthusiasm for service work.

The owner of a television receiver would surely not order and pay for spares unless he thinks he knows what he was doing. Even if he made a mess of the job, it's his own property he is spoiling.

It seems ludicrous to me that a man whose working day is spent among complex electronic devices should be compelled to take his five-valve receiver to the local village radio shop to be repaired by someone who probably fills in time mending punctures!

Fakenham, Norfolk.

"TECHNICIAN."

Tape Amplifier Design

I HAVE just seen R. C. Marshall's letter in your June, 1956, issue, commenting on my tape amplifier design (November, 1954, issue). The changes suggested by Mr. Marshall certainly represent a sound approach to the design of this particular feedback amplifier, although it may be mentioned that the record amplifier was found to be absolutely stable even with the original values.

It is possible to replace the triode outfit valve V_2 in the recording amplifier by a pentode. Using a large screen decoupling condenser, the amplifier oscillates with the recording head disconnected, but is stable if the recording head is connected. If a compara-

tively small screen decoupling condenser is used, the amplifier will be unconditionally stable. In the latter case, V_2 operates at low frequencies as a triode, which eliminates the cause of instability. At high frequencies, in particular at the bias frequency, the screen is effectively bypassed, and the high internal impedance is preserved. At low frequencies, the additional feedback owing to the unbypassed screen resistor is negligible and has practically no influence on the frequency response of the recording amplifier.

In my own equipment I am using a 6SH7 with a screen resistor of $1M\Omega$ and a condenser of $0.025\mu F$ between screen and cathode. R_1 , R_2 and R_{12} remain unchanged.

Tel Aviv, Israel.

ARIEH F. FISCHMANN.

“Economy in Receiver Design”

THE objections raised by G. N. E. Pasch (your October, 1956, issue) to the injection of a negative feedback voltage to the grid of the first audio amplifier via the diode-load-cum-volume-control can be completely overcome, without otherwise rearranging the circuit, if a simple bridge network is used. The accompanying circuit diagram shows the arrangement; component values are suggested, but these are, of course, fairly arbitrary.

The feedback voltage being developed across AB, point X will, of course, be at earth potential so far as feedback voltage is concerned and the operation of the diode is not disturbed. On the other hand, the maxi-

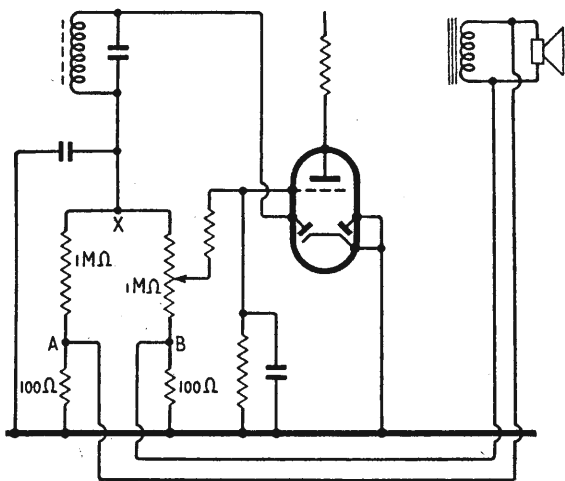

mum voltage fed back to the triode grid when the volume control is at its lowest point is reduced by 6 dB in this arrangement, but this is unlikely to be a serious disadvantage in a simple receiver of this type.

London, N.10.

IAN LESLIE.

“Transistor R.F. Amplifiers”

IN his article in the October issue, D. D. Jones presents low- and high-frequency equivalent circuits related in a way which we feel is misleading. The low frequency value of r_e is not necessarily given by $25/I_e$. This is true only if the low-frequency base resistance r_b and the high-frequency base resistance r_{b0} are equal; in practice r_b is usually significantly higher than r_{b0} , so that with $I_e = 1mA$, the low-frequency r_e may range down to the order of 2 ohms.

An equivalent circuit* from which Figs. 1 and 2 in the article may be derived is shown in the accompanying diagram. At high frequencies r_s may for all practical

* R. L. Pritchard, "Electrical Network Representation of Transistors—a Survey," *I.R.E. Transactions*, Vol. CT-3, No. 1, pages 5-21, March, 1956.

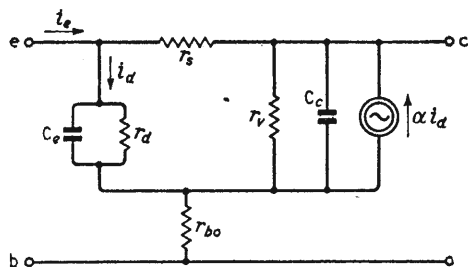

purposes be neglected and the circuit reduces to the high-frequency form given by Jones. To obtain his low-frequency T circuit, however, the parameter r_s cannot be neglected in the transformation. The resulting low-frequency r_e is not in general equal to $r_d (=25/I_e)$.

A further point relates to the choice of d.c. operating conditions for the transistor. Jones mentions the reduction of C_c resulting from an increased V_e ; a further benefit is that α is increased.

Imperial College,
London, S.W.7.

A. R. BOOTHROYD.
A. R. MOLOZZI.
D. F. PAGE.

Supply Voltage

I WONDER what the chairman of the South Eastern Electricity Board would do if his garage charged him for 100- and supplied him with 75-octane petrol?

Would he say, “Ah, well, the quantity is correct and the calorific value the same, so I will pay”? I somehow doubt it.

But already my voltage has been as low as 199 instead of 230, and winter hasn't started yet. Seldom is my television picture quality worth watching between 7 and 9 p.m.

Last February it dropped to 177 volts and all the mains engineer can tell me is that they can't find room for a sub-station anywhere.

Banstead, Surrey.

A. R. TURPIN.

But What About “Agenda”? [Ed.]

“FREE GRID,” whom I have long regarded as a firm and sure upholder of the classical basis of our language, seems to be losing his grip. Not once but twice in the January instalment of his incisive comments he treats “data” as singular. It is hardly surprising that in these days of very optional Latin this solecism should be increasingly common in technical circles, but one expects better of “Free Grid.” He must surely know that “ $g_m = 3.6$ ” and “ $\mu = 47$ ” are valve data, and “ $r_a = 13$ ” is valve datum? Or will he soon be writing about “a phenomena” or “a cherubim”? If he lets the humanities down again I shall have to consider writing the “Second Thoughts on Love Theory” (large negative values) he so much dreads.

While on this tack may I also reproach—though more gently—“Diallist” (who, if I'm not mistaken, is another classical scholar) for referring to the present type of British TV as “monochrome”? White, as he well knows, is as far removed from monochrome as it could be, and would more aptly be named “panchrome.” At the same time I do sympathize with his reluctance to keep on using the clumsy and (if the contrast control is properly set) inaccurate expression “black-and-white.” It is time we had a better word.

Finally, B. E. Jackson might care to note that single-setting resistance-current-voltage-power nomograms are less uncommon than he suggests. One by W. A. Barclay was published in *Wireless World* as long ago as February 17th, 1932, and repeated several times since; there is one in “Radio Data Charts” (5th edn.), and one in “Radio Laboratory Handbook” (6th edn.).

“CATHODE RAY.”

Improved Sync Separator

Single-Pulse Frame Synchronizing for Good Interlacing

By MICHAEL P. BEDDOES,* B.Sc.(Eng.), D.I.C., A.M.I.E.E.

THE composite synchronizing signal for British television consists of alternating trains of line and frame pulses.¹ During the period in which the frame is being scanned, line pulses only are transmitted. In the small interval between the end of the frame scan and the frame flyback a group of pulses at twice line frequency is transmitted to provide a trigger for the fly-back of the frame timebase and also to maintain synchronous operation of the line timebase. In

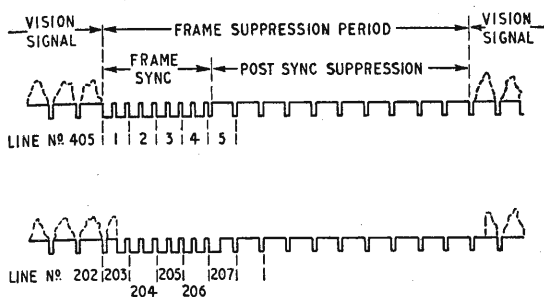

Fig. 1. B.B.C. vision waveform at the end of the frame scan; for even frames (above) and odd frames (below).

American television practice, on the other hand, the group of frame pulses is preceded and followed by "equalizing pulses" to facilitate accurate synchronizing of the frame timebase in the receiver.

At first sight, it might appear that a single RC integrating network could produce satisfactory frame sync pulses from the composite synchronizing signal. According to Patchett,² this is not possible because without equalizing pulses this method produces frame-sync pulses which differ slightly on odd and even frames. The slight difference makes accurate synchronizing of the frame-timebase and hence good interlacing difficult, if not entirely impossible to achieve. Various improved methods^{3, 4} have been developed for separating the frame pulses from the composite synchronizing signal. It is well known that, in certain cases, such methods can produce excellent interlacing.

However, suppose that the timebase fires slightly irregularly for odd and even frames. This would cause the initiation of flyback to vary between, for example, the first and second pulses of succeeding trains of sync pulses. Thus, although the frame lock might be considered to be satisfactory, perfect interlacing would only be possible over a strictly limited region within the locked range. According to Haantjes and Kerkhof⁵, even though a timebase has a tendency towards

irregular firing, a single, narrow and perfectly regular pulse will be conducive to the best interlacing. The single pulse frame sync separator described here is rather more elaborate than that developed by Haantjes and Kerkhof.

The process of obtaining the frame-sync signal from the video signal is normally done by cascading two separators. The output of the first (the picture/sync separator) is the composite sync signal, and that of the second (the frame/sync separator) is the frame sync signal. During each frame, the corresponding sync signal may be arbitrarily divided into a group of $202\frac{1}{2}$ line pulses and one of 8 frame pulses (Fig. 1). In order to provide a frame sync signal, the frame sync separator must have an output which is produced by the sudden transition from the line pulses to frame pulses, but not vice versa. The essentials of this particular circuit are shown in Fig. 2.

The triode V_1 is driven by the composite synchronizing signal. Its anode current is completely cut off by any sync pulse; in the conduction periods between pulses the full current flows. Thus, for the purposes of explanation, the circuit of Fig. 2 can be replaced by the simpler equivalent of Fig. 3 in which a resistance R (equal to the anode resistance of the triode) in series with a switch replaces V_1 . The switch is held open during sync pulses only.

Taking the line pulses first, imagine that the switch (Fig. 3) has been closed for a considerable time, and

* University of British Columbia.

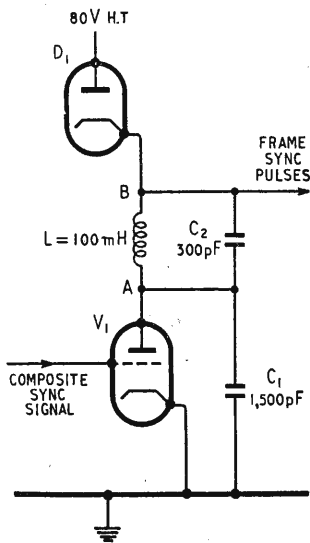

Fig. 2. Essential elements of the improved frame sync separator.

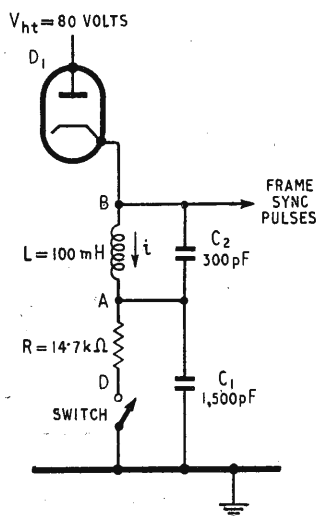

Fig. 3. Simpler version of Fig. 2, with a resistance and a switch representing the triode valve.

that the current i in the inductor has reached its steady value given by

$$i = I = \frac{V_{h.t.}}{R} = \frac{80}{14.7} = 5.43 \text{ mA} \quad \dots (1)$$

In the first line pulse, the switch is opened for 10 μsec . During this period, the damping is removed from the tuned circuit and i will decay as part of a sinusoidal oscillation whose period, T_1 (governed by L and $C_1 + C_2$), is 83 μsec . However, because the switch is open for considerably less than $T_1/4$, the current in the inductor cannot reach zero.

Following the line pulse, the switch is closed for 90 μsec . During this period very heavy damping is again applied to the tuned circuit and the inductive current rapidly asymptotes to the steady value I . Thus, in the period of the second line pulse, the inductive current follows a pattern similar to that outlined for the first pulse. This pattern is repeated for each line pulse in the long train of 202½ line pulses.

Experimentally, it was easier to observe the voltage waveforms at A and B than the current in the inductance. From Fig. 4, during a line pulse v_A is elevated, implying the decay of i . In the subsequent period, the waveform of v_A indicates, also by implication, that the steady value I is reached at about

the middle of the line scan. Nowhere within this cycle has the current in the inductor or in the diode reversed sign and therefore no output should, nor indeed does, appear at B.

Frame Pulse Pattern

Taking the frame pulses next, at the instant of the middle of the frame pulse, assume that the current i in the inductance is zero (Fig. 5) but the voltage across it, $v_A - v_B$, maintained by the charge in C_2 , is positive. The switch (Fig. 3) is open. The potential v_A will be held constant by the charge in C_1 . Although the potential v_B cannot be decreased because of the diode action, it can be increased. Therefore, during the decay of the charge in C_2 , voltage v_B is elevated as part of a sinusoidal oscillation with a period T_2 (governed by L and C_2) of 37 μsec .

The switch remains open for 20 μsec , in which period approximately half a cycle of the oscillation can take place. At the end of this period the potential difference, $v_B - v_A$, is now a maximum but beginning to diminish. During the ensuing conduction interval, the switch is closed for 10 μsec , and the current through R rapidly reduces the potential v_A . Concurrently, $v_B - v_A$ is also diminishing. In the middle of this conduction period* the potential of B falls to h.t. voltage and the diode closes. Immediately the mode of operation changes. The current in the inductance increases in the remaining 5 μsec of the conduction period.

During the period of the next frame pulse, the switch is opened for 40 μsec . The charge in C_1 reduces the current in the inductance and, simultaneously, the potential of A is elevated as part of a sinusoidal oscillation of period T_1 (83 μsec). In the instant a quarter of this period (20 μsec) later, the current in the inductance will be zero, and the voltage across it, $v_A - v_B$, will be positive. Thus, after this instant, a pattern follows which is similar to that already outlined. This pattern will be repeated for each frame pulse in the train of 8 frame pulses.

Experimentally, it was easier to observe the voltage waveforms v_A and v_B than the current i in the inductance. From Fig. 6, the potential v_A is elevated during the first half of the frame pulse, implying the decay of i . During the second half v_A is seen to be sensibly constant, held thus by the charge in C_1 . During the subsequent conduction period v_A is seen to decay rapidly. It is elevated once again during the first half of the subsequent frame pulse.

From Fig. 7, during the first half of the frame pulse, when the inductive current and also the diode current are falling to zero, the potential v_B is seen to be constant, held thus by the action of the diode. During the second half of the frame pulse when the diode is open, this potential can be seen to increase rapidly, but it decays even more rapidly during the ensuing conduction period. In steady-state, therefore, a single narrow pulse of voltage appears during each frame pulse and at first sight it might appear that what has been described is but one more circuit for separating the trains of frame pulses^{3,4} from the composite sync signal. This impression, however, is misleading, as will be shown below.

During the line pulses, the power supplied to the circuit (from considerations of the mark-to-space ratios) is 36 times that during the frame pulses.

* See appendix.

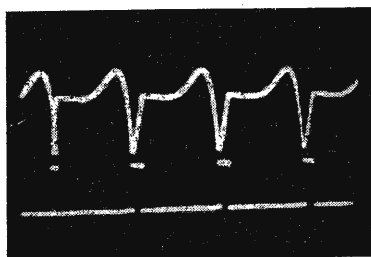

Fig. 4. Waveforms during a long train of line pulses; (above) line sync signal, (below) corresponding v_A .

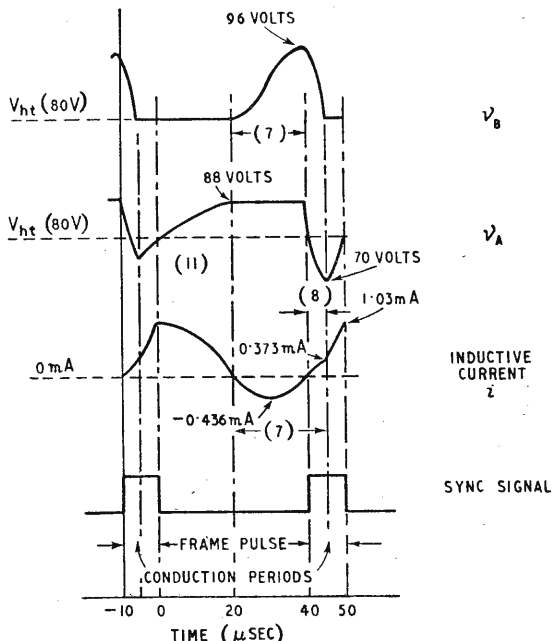

Fig. 5. Section of a long train of frame pulses. The numbers in brackets refer to the corresponding formulæ in the text.

nominal, while the permitted variation in the value of the inductance L (Fig. 2) was even greater, only a minimum value of 100mH being specified†. Such variations in the circuit values naturally produced observable changes in the waveforms. Between different receivers there was a variation in the number of minor pulses which followed the primary sync pulse; also, there appeared to be a small variation in the actual magnitude of this pulse. In spite of these variations, however, the resulting frame lock remained very precise, and the range of excellent interlace appeared to be substantially independent of the setting of the frame hold adjustment, provided of course that operation was within the synchronous range.

REFERENCES

- ¹ Blumlein, A. D., Browne, C. O., Davis, N. E. and Green, E. "The Marconi-E.M.I. Television System," *Journal I.E.E.*, 83, pp. 758-766 (1938).
- ² Patchett, G. N. "Faulty Interlacing," *Wireless World*, July 1952, pp. 250-254 and August 1952, pp. 315-319.
- ³ Townsend, G. B. "On overcoming the Non-Interlacing of Television Receivers which are accurately Synchronized," *Proc. I.E.E.*, Part IIIA, 1952, p. 643.
- ⁴ Attew, J. E. "A Frame Sync Separator," *Electronic Engineering*, February 1955, pp. 70-71.
- ⁵ Haantjes, J. and Kerkhof, F. "Deflection Circuits," *Proc. I.R.E.*, 36, March 1948, p. 407.
- ⁶ Jaegar, J. C. "Introduction to the Laplace Transformation with Engineering Applications," mimeographed copy reproduced by C.S.I.R. Melbourne, 1946, p. 24.
- ⁷ *ibid*, p. 26.

APPENDIX

TWO numerical analyses will be made, one for the line pulses and the other for the frame pulses. In each analysis, a particular set of initial conditions will be assumed for a particular instant in the cycle; this set will then be shown to be repeated at an instant one period later.

For the line pulses, imagine that just previous to a line pulse the current i in the inductance (Fig. 3) has reached the steady value I (formula 1). During the line pulse, the switch (Fig. 3) is held open for 10 μ sec and the charges in the capacitances C_1 and C_2 will drive a current into the inductance given by the familiar oscillatory equation

$$i = I \cos \omega_1 t \dots \dots \dots (2)$$

where ω_1 is the resonant angular frequency of L in shunt with the parallel combination of C_1 and C_2 and $I = 5.43$

mA. The period T_1 , $\left(= \frac{\omega_1}{2\pi} \right)$ is 83 μ sec. Thus, although

the current in the inductance is reduced, by the end of the 10- μ sec line pulse it is not zero and consequently current still flows in the same direction in the diode (Fig. 3). Therefore, the potential at B must remain at h.t., held there by the diode action. The potential at A during this time is given by

$$\begin{aligned} v_A &= v_B + \text{voltage of A relative to B} \\ &= V_{h.t.} - L \frac{di}{dt} \\ &= V_{h.t.} + \omega_1 L I \sin \omega_1 t \dots \dots \dots (3) \end{aligned}$$

From (3), v_A is elevated 12 volts above h.t. at the instant at the end of the line pulse. After the pulse is over, the switch is again closed. A representation of this part of the cycle may be obtained from Fig. 10, which shows the equivalent circuit. At $t = 0^-$ (i.e., just before the switch is closed), a charge equivalent to 12 volts is maintained by the capacitances C_1 and C_2 . At $t = 0$, however, a voltage step of - 80 volts is applied suddenly at point D. If e is the Laplace Transform of the voltage between

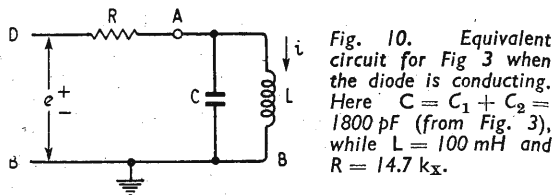

Fig. 10. Equivalent circuit for Fig 3 when the diode is conducting. Here $C = C_1 + C_2 = 1800$ pF (from Fig. 3), while $L = 100$ mH and $R = 14.7$ k Ω .

B and D, and i is the transform of the current in the inductance, then it is easy to show⁶ that

$$i = \frac{e}{p^2 LCR + pL + R}$$

Mathematically, the initial 12 volts can easily be accounted for by the following device. Consider that for all time 12 volts is applied between B and D but that a step of - 92 volts is applied suddenly superimposed at $t = 0$. Then, for $t > 0$, the - 92 volts and the steady + 12 volts add to produce the same effect as applying the - 80 volts step, while, for $t < 0$, the effect is that produced by + 12 volts alone. Thus the current in the inductance is given by

$$i = \frac{92}{p[p^2 LCR + pL + R]} - \frac{12}{pR} \dots (4)$$

the first main term being the contribution from the - 92 volts step, while the second term is the contribution from the steady + 12 volts. The inversion of (4) is readily performed using standard Laplace Transform techniques,⁷ whence

$$\begin{aligned} i &= \frac{92}{R} + \frac{92}{R} \left[\frac{\sin t \sqrt{\frac{1}{LC} - \frac{1}{4C^2R^2}}}{\sqrt{4 \frac{CR^2}{L} - 1}} + \right. \\ &\quad \left. \cos t \sqrt{\frac{1}{LC} - \frac{1}{4C^2R^2}} \right] \exp - \frac{t}{2CR} - \dots \\ &\frac{12}{R} \dots \dots \dots (5) \end{aligned}$$

where t is in microseconds from the closing of the switch and i is in milliamps. Because of the heavy damping, the transient terms in (5) decay extremely rapidly. For example, after 90 μ sec (the time for the line scan) the net current is $5.43 + 0.023 = 5.47$ mA, where the value 0.023 is the contribution from transient terms. Thus, the initial conditions assumed one period ago have substantially been repeated and the reasoning has completed a full circle.

On even frames, a conduction pulse of 90- μ sec duration precedes each train of frame pulses. On odd frames, however, the corresponding conduction pulse is only 40 μ sec, and the inductive current immediately before the frame signal is obtained by substituting $t = 40$ in (5). This gives $i = 5.35$ mA. Now, the current in the inductance immediately before the frame pulses can be regarded as proportional to the height of the first frame pulse. Therefore, the slight variation of this current (5.47 and 5.35 mA) ought to produce a corresponding variation in the magnitude of the frame pulse. Such variation was indeed observed but the small amount of this effect (2.5% computed) would probably not affect the quality of interlace. This variation could be reduced still further by using a valve with a lower anode resistance (Fig. 2).

For the frame pulses, at an instant in the middle of a frame pulse (Fig. 5) assume the following.

- (1) The current in the inductance is zero.
- (2) The potential at A is elevated 8 volts above h.t.
- (3) The potential at B is still at h.t., but the diode current is zero.

The voltage difference across the inductance is only
(Continued on page 87)

† Values of certain pass inductances exceeded twice nominal.

maintained by the charge in C_2 . Because the potential of A (Fig. 3) is fixed by the charge in C_1 , the potential of B, or v_B , will increase rapidly as part of an oscillation whose period T_2 is governed only by L and C_2 . Here $T_2 = 37 \mu\text{sec}$. Thus, if time t is measured in microseconds from the commencement of the frame pulse

$$v_B = (v_{h.t.} + 8) - \cos \frac{2\pi}{T_2} [t - 20] \quad \dots \quad (6)$$

where the first main term is the voltage at A and the second term is the voltage of B relative to A.

In a low-loss oscillatory LC circuit, the peak kinetic energy in the inductance very nearly equals the peak potential energy stored in the capacitance; i.e., $\frac{1}{2}LI_1^2 = \frac{1}{2}C_2V^2$ where V is the peak voltage across the capacitance and I_1 is the peak current in the inductance. Thus, the peak current which will flow into the inductance is given by

$$I_1 = 8 \sqrt{\frac{L}{C_2}} = 0.436 \text{ mA}, \text{ and therefore the current in the inductance is given by}$$

$$i = -I_1 \sin \frac{2\pi}{T_2} [t - 20] \\ = -0.436 \sin \frac{2\pi}{37} [t - 20] \quad \dots \quad (7)$$

From (6), it is clear that v_B can complete rather more than half of the cycle at T_2 in the $20 \mu\text{sec}$ remaining in the frame pulse; and at the end of this ($t = 40$), B will be elevated about 16 volts above h.t.; while, from (7) the inductive current will be approximately zero.

During the $10 \mu\text{sec}$ of the next conduction period, the switch is closed. Because there is no diode conduction, the potential of A can fall exponentially:

$$v_A = 88 \exp - \left[\frac{t - 40}{T_3} \right] \dots \dots \quad (8)$$

where T_3 is the time-constant formed by R and C_2 and has the value of $22 \mu\text{sec}$. During this time also

$$v_B = v_A + \text{voltage of B relative to A} \\ = 88 \exp - \left[\frac{t - 40}{22} \right] + \\ 8 \left[1 - \cos \frac{2\pi}{37} [t - 20] \right] \dots \dots \quad (9)$$

The instant that $v_B = V_{h.t.}$, the diode again conducts and

the mode of operation changes. From (9) this instant occurs at $t = 45$; i.e., $5 \mu\text{sec}$ after the start of the conduction period; while from (7) the corresponding inductive current is $+0.373 \text{ mA}$. Also at this instant

$$v_A = 88 \exp - \left[\frac{45 - 40}{22} \right] = 70 \text{ volts} \dots \quad (10)$$

In the $5 \mu\text{sec}$ remaining in the conduction pulse the diode is closed, and consequently the inductive current will be given by formula (5), though with the initial constants appropriately altered:

$$i = 5.45 - \frac{70}{14.7} \left[0.265 \sin 0.716 (t - 45) + \cos 0.716 (t - 45) \right] \exp \left[-0.0198 (t - 45) \right]$$

$$\text{At the end of the conduction period } (t = 50) \\ i = 5.45 - 4.76 \left[0.265 \sin 16.35^\circ + \cos 16.35^\circ \right] \times \\ \exp (-0.0794)$$

$$= 1.03 \text{ mA}$$

In the next frame pulse, the switch is again opened. The current in the inductance and the voltage at A are respectively given by (2) and (3) with I reduced to 1.03 mA .

$$\text{Thus } i = 1.03 \cos \frac{2\pi}{83} (t - 50) \\ \text{and} \dots \dots \quad (11)$$

$$v_A = V_{h.t.} + \frac{2\pi}{83} 1.03 \sin \frac{2\pi}{83} (t - 50) \times 10^{-3}$$

where t is once again measured from the beginning of the previous frame pulse and $L = 100 \text{ mH}$.

At $t = 70$, from (11) $i \approx 0$ and $v_A = 88 \text{ volts}$. These conditions obtain at the middle of the frame pulse and therefore the reasoning has completed the full circle correctly.

During the train of frame pulses, it has been shown that the current in the inductance immediately before a frame pulse is 1.03 mA , whereas the corresponding current immediately before the first frame pulse is of the order of 5.4 mA . Thus, the first frame pulse should exceed its fellows by a factor of 5.4. This in fact seems to be supported experimentally and closely follows the ratio derived by energy considerations alone in the main text.

BOOKS RECEIVED

Mathematics for Electronics with Applications by H. M. Nodelman and F. W. Smith. The mathematical processes useful in electronic engineering are discussed in theory and their application to specific problems is illustrated. Sections are devoted to the use of dimensions in checking formulæ, the solution of networks by determinants and matrices, the applications of series in non-linear circuits (e.g., intermodulation testing), methods of transient analysis, and the use of Boolean algebra in the analysis of switching circuits. Pp. 391; Figs. 131. Price 52s 6d. McGraw Hill Publishing Co., Ltd., 95, Farringdon Street, London, E.C.4.

The Application of Phase-coherent Detection and Correlation Methods to Room Acoustics: B.B.C. Engineering Division Monograph No. 9 by C. L. S. Gilford, M.Sc., F.Inst.P., A.M.I.E.E. and M. W. Greenway, M.Sc. (Eng.), D.I.C., A.C.G.I., Grad.I.E.E. Describes modifications of the pulsed gliding tone technique of displaying the transient response of rooms, designed to reveal more clearly the "singularities" responsible for coloration of the sound. Pp. 14; Figs. 14. Price 5s. B.B.C. Publications, 35, Marylebone High Street, London, W.1.

The Gramophone Handbook by Percy Wilson, M.A. Guide to the choice, installation and maintenance of equipment for the reproduction of gramophone records, with chapters on the care of discs and an introduction to tape recording and reproduction. Pp. 227; Figs. 56. Price 15s. Methuen and Co., Ltd., 36, Essex Street, London, W.C.2.

Television Explained by W. E. Miller, M.A., M.Brit.I.R.E. Sixth edition, revised by E. A. W. Spreadbury, M.Brit.I.R.E., of a guide to the functioning of the component parts of the modern television receiver, together with a chapter on installation and initial adjustment. Pp. 184; Figs. 87. Price 12s 6d. Iliffe and Sons Ltd., Dorset House, Stamford Street, London, S.E.1.

The Morse Code for Radio Amateurs by Margaret Mills. Advice on learning the code together with a graded series of exercises designed to give fluency up to a speed of 12 words per minute or more, and a glossary of amateur abbreviations. Pp. 18. Price 1s. Radio Society of Great Britain, New Ruskin House, Little Russell Street, London, W.C.1.

Wideband V.H.F. Converter

PREPARING FOR THE INTERNATIONAL GEOPHYSICAL YEAR

By G. P. ANDERSON, A.M.I.E.E.*

AS readers of *Wireless World* are aware, we are approaching a maximum in the 11-year cycle of sunspot numbers, and present indications are that this maximum is going to be higher than ever previously recorded, at least during the time that it has been possible to correlate activity on the sun with its effect on radio propagation on the earth. To the average enthusiast, the most interesting and easily observable effects are to be found on the frequencies ranging from 20 to 60 Mc/s or thereabouts, and this article describes apparatus that will enable the reader to extend the tuning range of a short-wave receiver to include this band.

During the last period of "sunspot maximum", signals from all over the world were being heard on frequencies up to about 50 Mc/s; many trans-Atlantic contacts were made by amateurs on frequencies of the order of 50 Mc/s, but attempts on frequencies only a few megacycles higher (56 Mc/s) did not meet with the same success. During last winter American signals were being heard regularly on frequencies up to 36 Mc/s, and sometimes higher, with very simple indoor aerials, and, of course, the 28-Mc/s amateur band was open to the world almost daily.

Apart from possible ionospheric paths, a fair indication of tropospheric propagation conditions on v.h.f. can be obtained by monitoring the B.B.C.

* Amateur Radio Station G2QY.

television channels, and a French TV station on about 41 Mc/s will serve as a useful sign that the 145-Mc/s amateur band is open in that direction. Final plans for the International Geophysical Year have not yet been published, but it is possible that some interesting signals may be radiated on v.h.f. in connection with this event.

Design of V.H.F. Convertors.—Due to the strength of signals when propagation conditions are favourable, fairly simple apparatus is often quite satisfactory, and a t.r.f. or "straight" receiver using modern valves could be used. However, a superheterodyne convertor used in conjunction with a shortwave receiver, or a broadcast receiver with a shortwave range, will produce much more satisfactory results. Such a convertor changes the frequency of an incoming signal on, say, 50 Mc/s, to a lower frequency, that can conveniently be about 5 Mc/s, and this "converted" or "translated" signal is then passed to a receiver tuned to 5 Mc/s.

In order to include the frequencies likely to be of most interest, the tuning range of the convertor should extend up to at least 60 Mc/s; the lower limit can conveniently be arranged to overlap the upper frequency of the existing receiver, thus, in effect, extending its tuning range. Although it is possible to use a switched system of coil changing, the writer preferred to use plug-in coils to minimize switching and other losses.

The simplest method of changing the frequency

Fig. 1. Theoretical circuit of the 5-valve convertor. The power supply is built on the same chassis.

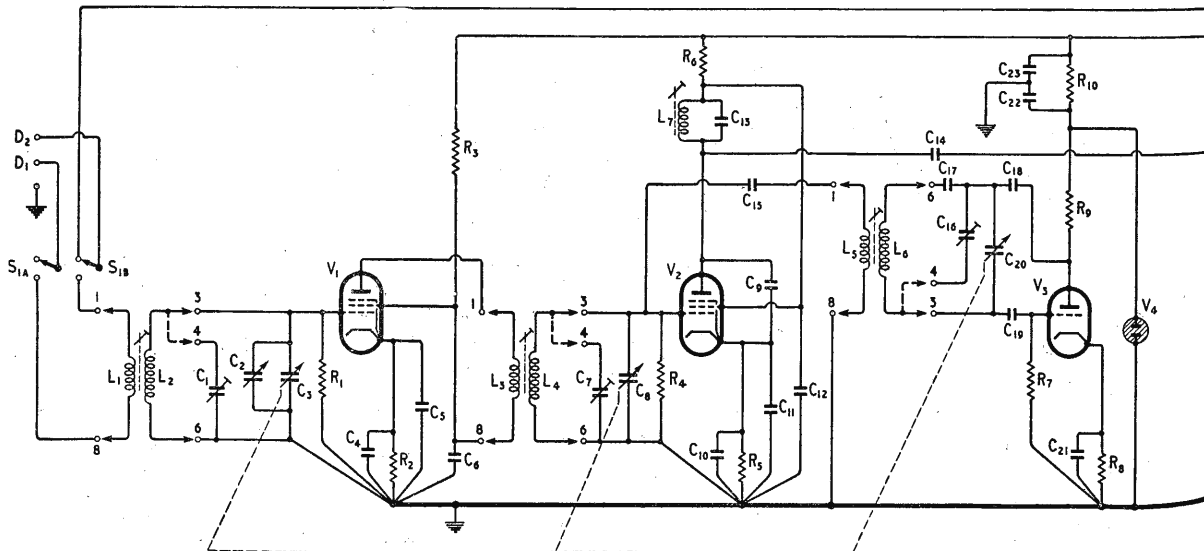

of the incoming signal is by means of a single valve of the heptode, triode-hexode, or similar type, in which one part of the valve serves as an oscillator and the voltage produced is injected into the electron stream of the other section, which functions as a mixer. Whilst such a unit is perfectly capable of giving a good performance, it suffers from the severe drawback that a strong signal is radiated from the oscillator. This may fall in the television bands and cause interference on local TV sets.

We can minimize this trouble, and at the same time obtain a useful improvement in performance, by inserting an r.f. amplifier between the aerial and the mixer; still further isolation of the oscillator voltages may be obtained by using separate valves

for the oscillator and the mixer, and using loose coupling between them for oscillator voltage injection. A further refinement is a stage of amplification at the translated frequency, thereby isolating the mixer from the effects of any changes in the main receiver, as well as giving some additional amplification. For convenience of operation all stages should be ganged, and it is useful to have an aerial trimmer and a gain control available on the front panel of the convertor.

The unit shown incorporates the features dis-

This view of the 5-valve convertor shows the inclined valves, plug-in coils, tuning capacitors and other recognizable components.

LIST OF COMPONENTS

Capacitors

- C₁, C₇, C₁₆ 20 pF trimmer
- C₂ 10 pF variable
- C₃, C₈, C₂₀ 50 pF variable
- C₄, C₆, C₁₀, C₁₇, C₂₁, C₂₂, C₂₃ 470 pF
- C₅, C₁₁, C₁₂, C₂₄, C₂₅, C₂₇, C₂₉ 1000 pF (Hi-k)
- C₉ 10 pF
- C₁₃, C₁₈, C₂₆ 100 pF
- C₁₄, C₁₉ 47 pF
- C₁₅ 4.7 pF
- C₂₈ 16 μF, 350V, wkg. electrolytic.

(Unless otherwise specified, capacitors can be silvered-mica or ceramic.)

Resistors

- R₁, R₄ 4.7 MΩ ¼W
- R₂, R₁₃ 270 Ω ¼W
- R₃, R₆, R₁₄ 4.7 kΩ ¼W
- R₅ 6.8 kΩ ¼W
- R₇ 22 kΩ ¼W
- R₈ 100 Ω ¼W
- R₉ 10 kΩ ¼W
- R₁₀ 8 kΩ 1W (see text)
- R₁₁ 1 kΩ ¼W
- R₁₂ 470 kΩ ¼W

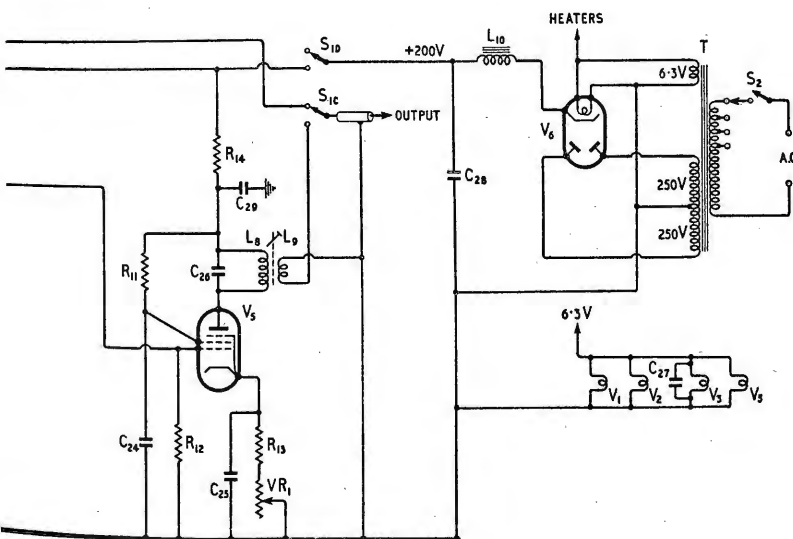
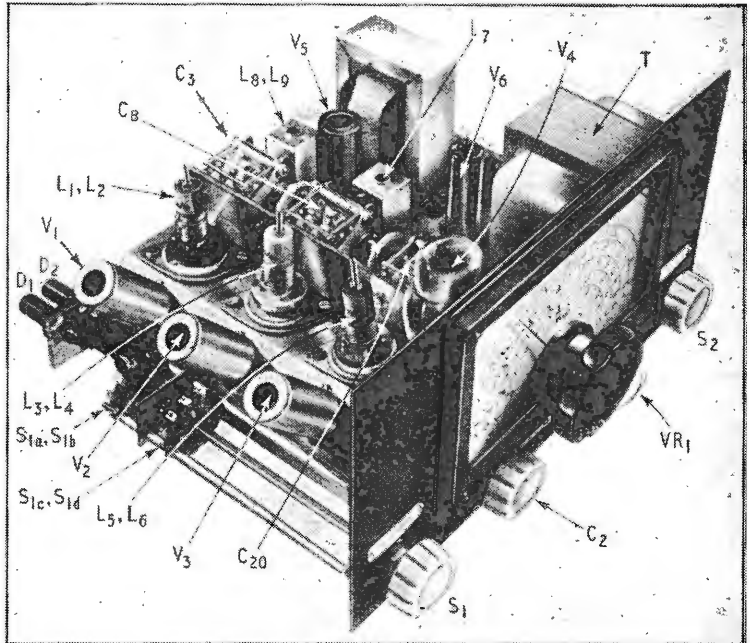

- VR₁ 10 kΩ 1W, variable
- V₁, V₂, V₅ 6AK5
- V₃ 6C4
- V₄ VR105/30
- V₆ 6X4
- S₁ 4-pole 2-way Yaxley-type switch
- S₂ Mains "on-off" switch
- L₁-L₆ See Table 1
- L₇ 50 turns No. 32 s.w.g.
- L₈ 50 turns No. 32 s.w.g.
- L₉ 10 turns, ditto.
- (L₉ is wound over "earthy" end of L₈.) Insulation, enamel.
- L₇, L₈ and L₉ wound on 0.3in diam formers, Neosid Type 5000/6E; dust iron core Drg 500; top plate Drg 5001. John Dale Screening Can Type DTV2.
- L₁₀ 20 H 40 mA choke
- T 250-0-250V, 40 mA; 6.3V, 1.3A.

Chassis

7½ in x 7½ in x 1½ in deep.

Panel

10 in x 5½ in deep.

cussed here, and includes simple voltage stabilization of the h.t. supply to the local oscillator. The power supply for the convertor is included in the unit. Plug-in coils are used, the range from 15 to 85 Mc/s being covered with four sets of three coils. The tuning capacitors are ganged and an aerial trimming control is provided on the front panel to compensate for the loading effect of different aerials. The trimmer also simplifies the "tracking" problem in a three-circuit tuner of this type. The other controls are: i.f. gain; convertor in/out switch, for changing the aerial over to the main receiver, and a mains on/off switch.

The circuit is shown in Fig. 1, and it will be seen that 6AK5 valves are used for the r.f. amplifier, mixer and i.f. pre-amplifier. A 6C4 valve serves for the oscillator. The h.t. voltage to the latter is stabilized by a VR105/30, the value of R_{10} depending on the voltage of the h.t. line. The value shown is suitable for an h.t. voltage of about 200. The circuit is fairly orthodox, but the need for R_1 and R_4 may not at first be apparent; they provide a d.c. path to earth for the grids of their respective valves when the coils are removed for changing the range. The capacitor C_9 across the mixer valve was not found to be necessary in the model shown, but from experience the writer has had with other v.h.f. convertors, it may be needed to prevent oscillation at the mixer output frequency. The power consumption of the convertor is 1.3A, at 6.3V, and 40 mA at 200V.

The main points to watch when constructing apparatus for the higher frequencies have frequently been stressed; summarized they amount to this; keep all leads short and the wiring rigid. The convertor shown is constructed with the valves inclined relative to the rest of the chassis in order to facilitate short wiring. A copper chassis should be used and the earth returns of each stage brought to one point, as indicated in the circuit diagram. Separate tuning capacitors are used and mechanically coupled, but electrically insulated from each other. Both sides of C_{20} are "live" to r.f. and consequently this capacitor must be insulated from the chassis. It is advisable to wire the heaters with screened lead, bonded at intervals to the chassis, and unless the lead connecting the convertor to the main receiver is reasonably short, it also should be screened. A good slow-motion dial is desirable, although a certain amount of fine tuning can be carried out on the main set.

The coils are wound on $\frac{1}{2}$ -in diameter formers, provided with $\frac{3}{8}$ -in dust cores for adjustment of inductance. The particular type specified in the schedule is made of polystyrene, and use may be made of the low softening temperature of this material to secure the turns of wire during the winding process. The writer found it convenient,

after soldering one end of the wire in Pin 3, to bend it at right angles just above the flange of the former (see Fig. 2), and to hold the wire so that it is resting against the body of the former. If now the wire is heated by carefully applying a soldering iron to it at a point near to the body of the former as shown, it will be found that after a very short time the wire begins to sink into the polystyrene. The iron should now be removed, and the wire and former held in position for a few seconds to allow the polystyrene to harden. Winding the coil may then proceed, keeping the wire taut, separating the turns, and, if felt necessary, repeating the heating process at intervals. After the required number of turns has been put on, the last turn should be secured in the same way as the first and the end inserted into Pin 6 and soldered. The other winding may be added in the same way, and to complete the coil a coating of polystyrene varnish should be applied, which will effectively "embalm" the windings, and prevent any risk of turns moving during handling. If formers of clear polystyrene are used they may be colour coded by applying a coat of paint to the inside of the former.

The coils used in the prototype unit plug into standard octal sockets, which may be colour coded to correspond to the appropriate coils. These sockets, like the valveholders, should be of high-grade ceramic or similar material, with good v.h.f. properties. Details of the windings are given in Table I, from which it will be seen that certain ranges are "padded" with extra capacitance in order to spread the tuning over the more populated frequencies; with one exception these capacitors are fitted in the wiring of the convertor (at C_{11} , C_7 and C_{16}) and are brought into circuit by joining tags 3 and 4 of the appropriate coils. It may also be observed that Band B includes both the 21- and the 28-Mc/s amateur bands.

Provided the layout and coil data are followed fairly closely, no difficulty should be encountered in aligning the convertor to provide an output signal for a set tuned to 5 Mc/s. The first step is to adjust the i.f. pre-amplifier to this frequency, and this may be done by setting "i.f. gain" to maximum (with the convertor switched on and connected to the receiver), and adjusting the dust cores in L_7 , L_8 and L_9 for maximum "noise" in the loudspeaker. The ranges covered by the oscillator may then be set using a signal generator or a grid-dip oscillator, and remembering to adjust the inductance at the low frequency end of each range, and the capacitance trimmer at the high frequency end, if necessary. In the prototype unit one value of capacitance served for most ranges, but due to differences in wiring it may be necessary to use different values for each range, in which case the capacitors could be mounted on each coil; this was done in the case

TABLE I. COIL WINDING DETAILS

Range	Coverage	L_1 Turns	L_2 Turns	L_3 Turns	L_4 Turns	L_5 Turns	L_6 Turns	Notes
A	15-22 Mc/s	2	8½	4	8½	2	7½	Pins 3 and 4 joined.
B	21-30 Mc/s	1	5½	2	5½	2	4½	Pins 3 and 4 joined.
C	30-53 Mc/s	1	2¾	2	4¾	2	3	L_6 has 13pF across it.
D	40-85 Mc/s	1	3	2	3½	2	3½	

All are wound with 22 s.w.g. tinned copper wire, on $\frac{1}{2}$ -in diam slug-tuned formers (Denco Maxi-Q, 6-pin octal based). Enamelled wire may be used if preferred. Turns are spaced by the diameter of the wire. Individual pairs of coils for each range (i.e. L_1 and L_2 ; L_3 and L_4 ; L_5 and L_6) are wound on the same former, end to end with about $\frac{1}{16}$ in spacing between them.

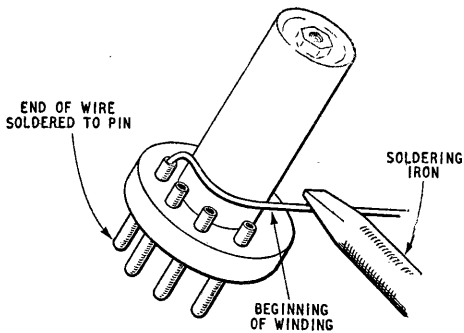

Fig. 2. The end turns on the polystyrene coils can be fixed in position by applying a hot soldering iron as shown here.

of L_6 (Range C), where an additional 13 pF was needed. The value of the padder capacitor C_{17} appears to be a good compromise and gives satisfactory tracking over all bands. However, some experiments may be useful in individual cases to obtain optimum results.

Having adjusted the oscillator range, the signal frequency circuits may be aligned, again adjusting the inductors for maximum signal near the low frequency end of each range, and the capacitors at the h.f. end. (This subject has been dealt with thoroughly in a number of publications and the reader is referred to them if he should require further information.)

Switch S_1 enables the convertor to be put in or out of circuit without having to manually change-over plugs, and in the "out" position the aerial is connected to the main receiver, and the convertor is disconnected.

Aerials.—The unit may be used with more or less any length of wire as an aerial, and if a single "long wire" aerial is used, it should be connected to terminal D_2 of the convertor, D_1 being strapped over to the earth terminal E. Care should be taken to make these connections correctly, so that the aerial is connected to the output socket when S_1 is set to "out."

On the higher frequencies, however, greatly improved results can be obtained by using resonant aerials; that is, aerials the lengths of which are chosen to tune to the particular frequencies in which one is interested. A convenient length consists of a half-wavelength of wire, that is, one 5 metres long for reception on 10 metres, and although such an aerial connected as described for a "long wire" will give good results, its efficiency is severely limited by the fact that, being only a short length of wire, most of it will be screened by being inside a room. It is preferable, therefore, to place the half-wavelength of wire as high and as clear of buildings as possible, and connect it to the receiver by a transmission line, that will convey signals from the aerial with little loss, and at the same time pick up minimum signal itself, thus reducing the effects of man-made static. Much information has been published on aerial design, but for the purpose of this article it will be sufficient to give the formula for determining the length of a half-wave aerial; this is

$$l \text{ (feet)} = \frac{462}{f \text{ (Mc/s)}}$$

If the wire is cut at the centre and an insulator

inserted to separate the two halves, and a length of suitable feeder used to connect it to the receiver, it can be erected well away from the house. Balanced feeder of the correct characteristic impedance of 75 or 80 ohms is available, but an alternative may be made from electric light "flex," preferably plastic insulated, which has approximately the same impedance. It is, however, more "lossy," and is liable to be even more so in damp weather. In either case the ends of the two conductors forming the feeder should be connected to D_1 and D_2 , the strap from D_1 to E not being required; terminal E may be connected to earth. Coaxial feeder of the type used for connecting TV aerials and receivers would be satisfactory also, the centre conductor being connected to D_2 , and the sheath to D_1 .

The half-wave aerial favours reception of signals from directions at right angles to its length, and this factor can be made use of if reception is required mainly from a particular direction; but for general (or omni-directional) coverage the aerial may be erected in a vertical position. As a half-wavelength at 28 Mc/s is about 16 ft and at 50 Mc/s only about 9 ft it is quite a practical proposition to erect such an aerial. The design of more elaborate aerials and arrays is beyond the scope of this article, and in any case such aerials are unnecessary for the listener who only wants to hear "what's going on" on the very high frequencies.

CLUB NEWS

Birmingham.—A demonstration of high-quality sound reproduction will be given to members of the Slade Radio Society by a representative of Whiteley Electrical Radio Company on February 15th. At the first meeting in February (1st) G. A. Swinerton (G6AS) will speak on operating in the DX bands. In addition to the fortnightly meetings held at 7.45 at Church House, High Street, Erdington, there are instructional and constructional classes every Tuesday and Wednesday evening, and the club station (G3JBN) is available every day for use by members. Sec.: C. N. Smart, 110, Woolmore Road, Erdington, Birmingham, 23.

Bradford.—The subjects to be covered by speakers at the meetings of the Bradford Amateur Radio Society on February 12th and 26th are, respectively, oscilloscopes (by G. F. Craven), and transformers (by P. Howarth). Meetings are held at 7.30 at Cambridge House, 66, Little Horton Lane. The fortnightly meetings are preceded by half-hour morse classes. Sec.: F. J. Davies (G3KSS), 39, Pullan Avenue, Eccleshill, Bradford, 2.

Bury.—The February meeting of the Bury Radio Society will be held at 8.0 on the 12th at the George Hotel, Kay Gardens, when H. A. Rothwell (G6QT) will demonstrate an all-transistor broadcast receiver. Sec.: L. Robinson, 56, Avondale Avenue, Bury.

Leicester.—Dekatrons and other counter tubes will be covered by M. H. Kind (G3GXZ) in his lecture to the Leicester Radio Society on February 11th at 140, Highcross Street. Sec.: J. Tranmer, 4, Grocot Road, Evington, Leicester.

Newbury.—J. H. Etheridge, of Cinema-Television, will speak about the flying-spot particle resolver at a meeting of the Newbury and District Amateur Radio Society on February 22nd. Meetings are held at 7.30 at Elliott's Canteen, West Street. Particulars are obtainable from 83, Newtown Road, Newbury.

Sidcup.—The next meeting of the Cray Valley Radio Club will be held at the Station Hotel, Sidcup, on January 22nd at 8.0. C. Usher (G2CCD) will give a talk entitled "Antennas for the amateur." Sec.: S. W. Coursey (G3JJC), 49, Dulverton Road, New Eltham, London, S.E.9.

Wellingborough.—On February 28th G. Abrams will address members of the Wellingborough and District Radio and Television Society on "Basic audio amplifiers." Arrangements are being made for a Mullard lecture and film on valve manufacture on the 21st. Meetings are held each Thursday at 7.30 at Silver Street Club Room. Sec.: P. E. B. Butler, 84, Wellingborough Road, Rushden.

NEGATIVE RESISTANCE

The Answers to Last Month's Questions

By "CATHODE RAY"

A FRENCH reviewer* has remarked that it is my custom to take supposedly simple things and show how obscure they are; and then, when the fog has become really dense, to wave a magic wand and clear it away. That may be all very well when the fog obeys, but last month it tended to thicken continuously, necessitating a postponement of the trick. In case you haven't meanwhile found your own way out or lost interest, the attempt will now be made, with apologies for any inconvenience.

The problem, you may remember, concerned negative resistance—as provided, for example, by dynatron or transistor—in circuit with positive resistance. Both kinds of resistance can be represented as voltage/current graphs. Fig. 1 shows the

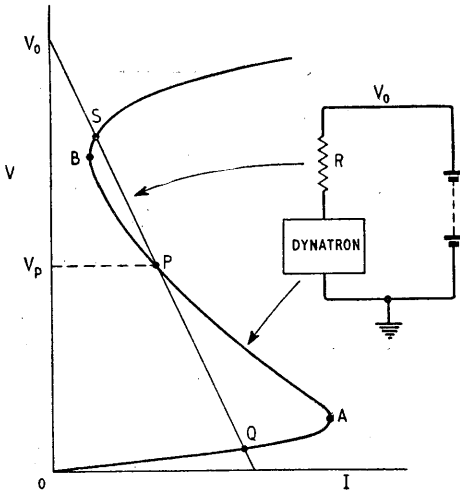

Fig. 1. Voltage/current graphs of the two resistive elements in the circuit shown. The curved line QAPBS represents, to the scales beginning at the normal origin O , the resistance of the dynatron, which is negative between A and B . The straight line V_0SPQ represents the wholly positive resistance R , to an inverted voltage scale beginning at V_0 .

characteristic curve of a dynatron; between A and B its resistance is negative, indicated by the line sloping the "wrong" way—current decreasing with rise in voltage. The straight line represents the linear positive resistance R ; and to see how the total voltage V_0 is shared between it and the dynatron we plot it to an inverted voltage scale, beginning at V_0 as its zero and increasing positively downwards. So the downward slope of this line indicates positive resistance all the way. The amount of resistance appears as steepness of slope. The only points on the diagram corresponding to equal current through both resistances are those which are common to both lines.

With two positive resistances only one such point is possible, but a peculiarity of negative resistance is that the same total voltage can sometimes be divided between the two resistances in more than one way, with different currents; for example, P , Q and S in Fig. 1.

We found by experiment that we could set the circuit to point P by tying down the junction between positive and negative resistances to a tapping V_0 on the voltage source, but that this point was unstable, because immediately the tapping was disconnected the voltage flipped to Q or S and stayed there. If, however, R was lower, as in Fig. 2, only one situation was possible.

Again by experiment we found that the negative resistance provided by a point-contact transistor with common base bias has a different kind of V/I curve, as in Fig. 3; but that in spite of the fact that at and near P the relative slopes of the positive and negative resistances are the same as in Fig. 2, this circuit turns out to be unstable and flips to Q or S just like Fig. 1. So our theory, based on Figs. 1 and 2, that the circuit is unstable when R is greater than the negative resistance and stable when it is less, broke down, and we were faced with Thomas Roddam's poser—how can the circuit, set to P , know whether it is stable or unstable without going to see which way the negative resistance bends? And how can it do that if it is stable? And how can it do it anyway, seeing that it can't move from P without there being more than one current or voltage in the same place at the same time, which is impossible?

We had been given a possible clue to the last of these questions by Mr. Roddam, when he pointed out that no real circuit is free from reactance. In practice

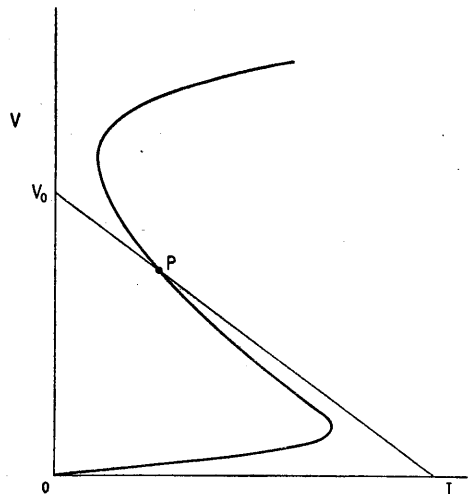

Fig. 2. As Fig. 1, except that R is less than the negative resistance of the dynatron.

*F.A. *Toute La Radio*, November 1955. p. 391.

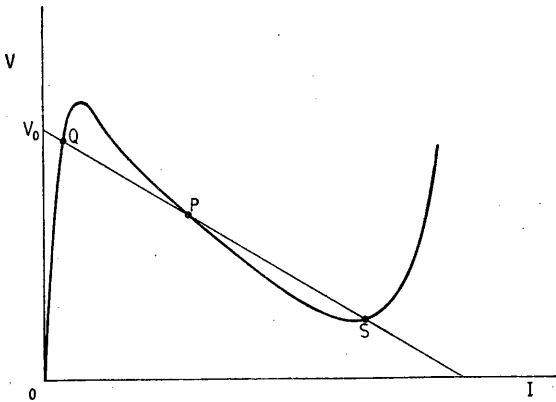

Fig. 3. Here the curved line represents the input resistance of a transistor circuit (Fig. 6).

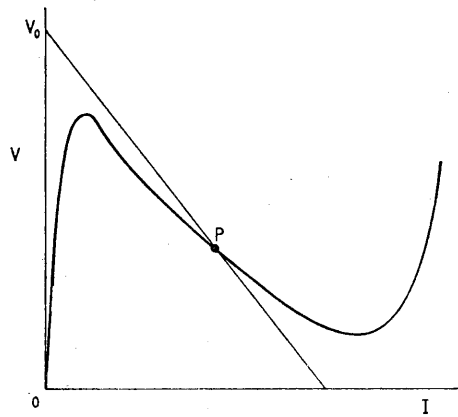

Fig. 4. As Fig. 3, except that R is greater than the negative input resistance of the transistor circuit.

there is always some stray capacitance across the dynatron in Fig. 1, and the current from this as its voltage changes between P and S or Q is in the right direction to bridge the current gap between the two lines during this change, and the amount of current required controls the speed of the change. We demonstrated this by making the capacitance large, slowing the process down so much that we could easily follow it on milliammeters.

That particular problem seemed to have been disposed of very neatly until we applied it to the transistor circuit. Because the two lines above and below P in Fig. 3 are on opposite sides of one another as compared with Fig. 1, the capacitance current is only in the right direction to bridge the gap between the two lines when the voltage is moving *towards* P, which therefore ought to be a stable point. But experiment showed that even with as much as $300\mu\text{F}$ across the transistor it was most definitely unstable!

Meanwhile we had got no nearer the answer to Roddam's question; and our shunt capacitance theory, demonstrable though it was in connection with Fig. 1, led us into the most frightful dilemma with Fig. 4, which illustrates the transistor in series with a high resistance and shunted by a capacitance. Near P it is identical with Fig. 1, so presumably the slightest displacement causes capacitance current that displaces it more, and so on, just as happened with the dynatron; but the current gap, instead of closing up at Q or S, widens continuously, causing the capacitance voltage to change faster and faster; but the negative resistance characteristic makes that impossible, for the voltage change actually reverses! We tried it, and found that the current and voltage oscillate continuously to and fro between the bends. But how does it manage to get into reverse there, contrary to our current-gap theory? And how is P in Fig. 4 unstable in spite of there being only one intersection, as in the stable Fig. 2?

Two Kinds of Resistance

It was with all these awkward questions unanswered that I was callous enough to leave you last time. In the meanwhile I have thought up some answers, which I hope will have been worth waiting for.

It is difficult to know where to start, but first of all let us tackle the question why P in Fig. 2 represents

a stable condition whereas in Fig. 3—which in the region of P is absolutely the same—it is unstable. That was the original Roddam problem.

Because diagrams of various kinds are such valuable mental aids, there is a danger of relying on them too completely, overlooking their limitations. Our ideas (if you will pardon my assuming that you, too, were taken in) last month were heavily based on voltage/current graphs, in which negative resistance appears as a slope downward from left to right. From this point of view there is no difference whatsoever between a portion of negative-resistance characteristic plotted from a dynatron and one from a transistor, provided their slopes are both the same. Yet they behave quite differently in practice. Since negative resistance is a particular relationship between current and voltage, and it is that relationship which is expressed by the graph, can two identical pieces of graph possibly represent different kinds of negative resistance?

The difficulty in seeing a difference between two resistances that appear identical may perhaps be that we are too much under the spell of Ohm's law. If we increase the e.m.f. applied to a 500-ohm resistor by 10 volts we know that the current through it will rise by 20 milliamps. We also know that if we increase the current through it by 20 milliamps the p.d. across it will rise by 10 volts. Cause and effect are interchangeable. It is the same with pressure and rate of water flow through a pipe. But if a fireman uses the water to knock a man down, cause and effect are not interchangeable. A man falling down doesn't necessarily cause water to gush out of a hose. And because the relationship between current and voltage in a valve or transistor can be graphed in the same way as for a resistor, it does not entitle us to assume that the same reversible cause-and-effect holds good. We have already seen that although the passing of I_p milliamps through the device illustrated in Fig. 5 necessarily causes the p.d. across it to be V_p volts, applying V_p volts to it doesn't necessarily drive I_p milliamps through it. It might be I_q . Or I_s . In this case it is only by regarding current as the cause and voltage the effect that we can get an unambiguous result. This kind of negative resistance is therefore called current-controlled. Conversely, the dynatron is a voltage-controlled negative resistance.

The persistent inquirer will object that distinguishing them by these names doesn't properly

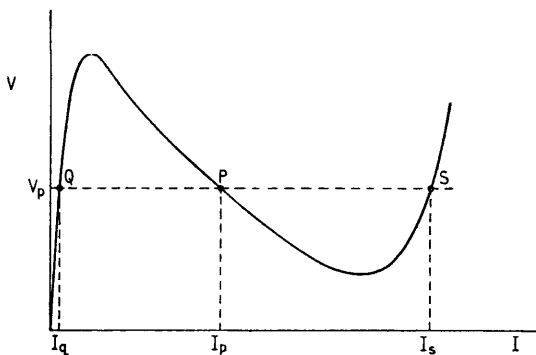

Fig. 5. This is the characteristic curve of a current-controlled negative resistance, because the value of current definitely decides the potential drop, whereas the reverse is not true.

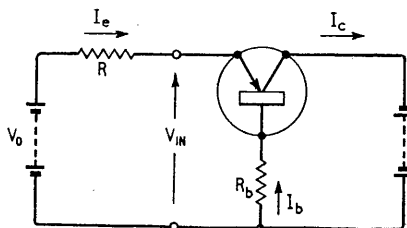

Fig. 6. Diagram of transistor circuit used to experiment with current-controlled negative resistance.

answer the question, for in order to name them we had to take a look at the bends in the curve, whereas the actual circuit appears to know the difference while it is still on the straight near P. So we shall have to go into the matter more closely.

Treating the transistor characteristic in Figs. 3 and 4 in the same way as for ordinary resistance, we would conclude that raising the input current from point P was bound to make the voltage fall, and reducing the voltage was bound to make the current rise. But let us look at the circuit represented by this graph: Fig. 6. Here, I_e and V_{in} are the current and voltage defining the transistor input resistance. Suppose we raise the input current I_e , either by raising an already large V_0 through an R sufficiently large for any changes in the potential of the emitter to have only minor influence on I_e , or by reducing R . These alternative procedures are represented in Fig. 4 by raising V_0 , keeping the slope of the R line the same, or by decreasing the slope of the R line, keeping V_0 the same. In either case, the diagram shows that P is shifted downwards, indicating the rise in current we aimed at, and also a fall in voltage. The same result can be predicted from Fig. 6 by a knowledge of point-contact transistor action. The rise in I_e , which, without I_c , would cause the voltage drop across R_b to increase, so increasing V_{in} , actually causes a bigger rise in I_c , which passes through R_b the opposite way, so the net result is a fall in V_{in} . The circuit behaves as the graph predicts.

Now let us reduce V_{in} directly, by reducing V_0 through a comparatively low R as in Fig. 3. Fig. 3 predicts a resulting rise in I_e . And so it would be if cause and effect were reversible, as with ordinary resistances. But let us consider it with Fig. 6. The first effect of a small reduction in V_{in} is to

reduce the voltage available for driving current from emitter to base. So I_e falls. That immediately causes a bigger fall in I_c , which makes the base less negative; that is, the base potential rises to meet the falling emitter potential, further reducing I_e . So the slightest reduction in V_{in} causes I_e to fall with a trigger action, the rate of cut-off being limited only by the time taken by the electrons and holes inside the transistor to do their stuff, as studied by us in the last September issue. The process is only saved from going on for ever by the top bend, where the transistor input resistance becomes positive and a stable position Q is taken up. If the trigger had been pulled in the other direction—as it can be now, by raising V_0 until the hump above Q has been cleared—it flies to the alternative stable point S.

Effect Follows Cause

We see, then, that an actual transistor circuit reacts to a voltage change near P in exactly the opposite way to that predicted by the V/I diagram. This is because it is a current-controlled negative resistance, so is affected by the applied voltage change only in so far as that changes the input current, which in turn changes the input voltage in the opposite direction. But it can't work in the reverse order, any more than the man falling down can make water come out of the hose. It is true that if, when we lowered V_0 , some playful demon had intervened for a microsecond or two, increasing I_e just in advance of us, our action would have sustained this result after the demonic influence had disappeared, for the increase in I_c would by then have made the base move considerably more negative than the emitter, so increasing the voltage between them and hence also I_e and I_c , in accordance with Fig. 3. Presumably also a shunt capacitance would then have acted always in such a way as to turn any excursions back towards P, so making it a point of stability. But science is based on the assumption that demons, if any, do not interchange cause and effect in this way; and Fig. 3 is invalid for control by voltage. Hence the complete and instant failure of every experiment I could devise to hold the circuit at P.

Incidentally, my fanciful closing remark last month (about my having to see this month's issue to get the answers) was really a rather subtle clue, because the only reason for its fancifulness was its reversal of cause and effect.

The problem of the gap between the two lines when moving from P to Q or S does not arise, because the extremely brief period of the journey is occupied by the internal electronic processes I mentioned, during which time the transistor has no static characteristic curve that one can draw on a V/I diagram.

In the same way it can be seen that because the negative resistance of a dynatron is voltage controlled it is unstable with a resistance greater than the negative slope, as at P in Fig. 1, whence there would be a flip to Q or S even if all shunt capacitance could be completely removed. The fact that the capacitance explanation is also true for this particular arrangement is just one of those awkward coincidences that make it so easy to confuse two different issues and draw fallacious conclusions. Fig. 1 is just Fig. 3 with current and voltage interchanged; it is,

(Continued on page 95)

in fact, the dual* of Fig. 3, and since the dual of shunt capacitance is series inductance we would expect series inductance to have the stabilizing influence we sought from shunt capacitance in the transistor circuit. The diagram with which we "proved" the stability of P in Fig. 3 also serves for inductance in Fig. 1 if dualized by interchanging current and voltage (Fig. 7), for the current-bridging effect of the changing voltage across the shunt capacitance becomes a voltage-bridging effect due to a changing rate of current through the series inductance. But, as with the transistor, this stabilizing effect is of academic interest only, for it is overridden by the impossibility of effect preceding cause.

In short, the answer to our original question (How does the circuit know whether it is unstable, as in Figs. 1 and 3, or stable, as in Figs. 2 and 4, without departure from P to see whether the negative resistance curve closes in to a Q and S or opens out?) is that a given negative slope around P in a V/I graph can represent either of two different kinds of negative resistance—current-controlled and voltage-controlled—and since this nature of the negative resistance in the actual circuit determines which is cause and which is effect, and effect is bound to follow cause, the stability or instability is determined. We have already studied Fig. 3 at length and seen why P is unstable. In Fig. 2, where the diagram at P is identical, the situation represented is nevertheless different, because a slight lowering of voltage is a direct cause in its own right, which increases the current, which admittedly drops somewhat further the voltage available for the valve and so extends the original action, but (with the relatively low positive resistance represented in Fig. 2) only to a limited degree. An infinitesimal displacement from P is sufficient for the nature of the negative resistance to be tested and for the circuit to flip or stay put as the case may be.

But what, you may ask, if a current-controlled negative resistance had a characteristic curve as in Fig. 2—or just continued negative all the way, without bends—and flipped madly on at goodness knows how many volts and milliamps per micro-second, trying in vain to find a stable point that did exist?

The continuous negative resistance can be ruled out for a start, because negative resistance is not a thing that can come from a passive component like a resistor; by its nature it delivers more power than it receives, and since there is no such thing as "perpetual motion" the power must come from somewhere, such as a battery, which of course is limited; and usually the device through which this power is administered—the valve or transistor—is even more limited, and sooner or later in both directions its resistance must revert to positive—hence the bends. The bends being granted, they must be such as to make possible more than one current at a given voltage, or more than one voltage for a given current, as in Fig. 2. If the former, voltage cannot be the controlling interest, else there would be no ambiguity; the negative resistance must be current-controlled. Vice versa for Fig. 2. So there is no fear of our nightmare coming true.

If you suppose that by this time the now celebrated Roddam question has been completely and

satisfactorily answered from all possible angles and we can go home, may I remind you of two little things. The first is that although some of us jibbed at Roddam's own answer as being not entirely obvious to the dim-witted, we never questioned its correctness. His answer, if you remember, was based on the existence of circuit reactance. Now our following up of this clue was rather unfortunate, because it led us quite a long way up the garden, and it was only when we dismissed reactance altogether as the determining factor in the problem that we got somewhere. Was Roddam wrong, then? Or are we?

Oscillations or Flips?

It seems (I hope so, anyway) that we are both right as far as we go. The discrepancy is removed if we recognize two kinds of instability: the kind we have been considering, which we might call flip instability; and the kind Roddam was considering, which we might call oscillation instability. Our kind is the inability of a circuit with negative-resistance to stay at the middle point of three; for example, P in Figs. 1 and 3. The reason is the fact that effect comes after cause, not before; a fact that over-rides anything that reactance can do. The gap between the negative and positive resistance characteristic curves needs no filling, because during the flip the negative-resistance characteristic is in a state of flux and doesn't really exist as a static curve.

The second thing to recall is that in attempting to set the circuit an impossible and absurd task we stumbled across oscillation instability—with capacitance across the transistor and a high resistance in series, as represented by Fig. 4. (Incidentally, the same thing happens with a dynatron and low resistance (Fig. 2) if there is inductance in series—as the dualists among us would expect.) Theory seemed to indicate that the nightmare "irresistible-force-and-immovable-object" situation would take charge, the speed of flip increasing to infinity and even beyond. But the thing oscillated to and fro,

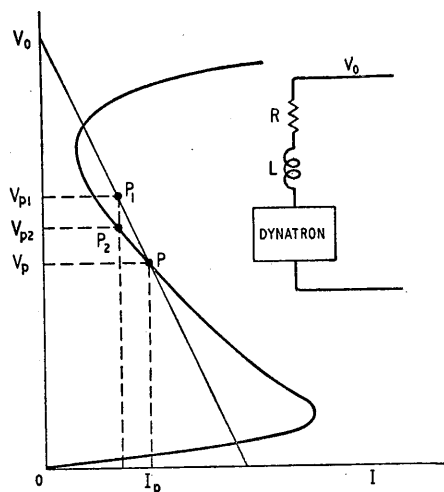

Fig. 7. A series inductance L makes possible a gap V_{p1} — V_{p2} between the voltages across dynatron and resistance R , provided that the current through all three circuit elements is changing in the direction away from P .

**Wireless World*, April 1952; also *Second Thoughts on Radio Theory*, Chap. 35.

and we haven't yet found any explanation for the reversal at each bend.

When I put an oscilloscope across R_b in the transistor circuit it showed that the speed of flip was indeed very great. One could tell not only by the fact that during it the trace was as near vertical as one could see, indicating an immeasurably small time period, but this vertical trace was almost invisible, showing that the ray was moving at very high speed. However, the speed of current change could never actually reach infinity, for at least two reasons. The first is the already-mentioned finite speed of electronic action inside the transistor, which renders the negative-resistance curve invalid at very high rates of change. The second is that every circuit has some inductance, and however small it was it would set up an infinitely large voltage if the current changed infinitely fast. So the current from the shunt capacitance not only causes an increasing horizontal separation of the two working points P_1 and P_2 but also a vertical separation, representing the voltage of self-induction. One can therefore visualize the two points starting off side by side; then one rising above the other, overtaking it horizontally, and driving the other in the opposite direction, where it follows.

In a transistor circuit without added inductance, in which oscillation is of a sawtooth and pulse (or relaxation) type, my guess is that the electronic time delay is likely to be the larger influence. If inductance is added in series with the capacitance, one gets an acceptor circuit which is in effect a low-impedance dynamic load in parallel with R , swinging it round from the Fig. 4 position to the flip-unstable position (Fig. 3). But now it is not merely flip-unstable, for being a dynamic or oscillatory load the inductance reverses the motion smoothly at the end of each half-cycle, and oscillation is more nearly sinusoidal.

The behaviour of the dynatron, with series inductance to convert the stable Fig. 4 into oscillation instability, is the dual of what I have just described. But the electronic action is much swifter in the dynatron, and the inductance is invariably shunted by at least some self-capacitance, making a rejector circuit, so my guess is that capacitance is here the main reversing influence. The effect of the high-impedance oscillatory circuit in series with the comparatively low R in Fig. 2 is to swing the load line up to the Fig. 1 position.

So in the end we find that, out of Figs. 1-4, 1 and 3 are the unstable ones, and 2 and 4 the stable. This is on the understanding that 2 and 4 do not have hidden about them enough reactance to bring the load line at some frequency or other into the 1 or 3 position.

If R in Figs. 1 and 3 is a simple positive resistance it is effective at all frequencies down to zero, and there is no reversing agent, so it just flips once to a stable point, Q or S. Supposing there could be no reactance at all the speed of slip would be governed entirely by the speed of electronic processes in the negative-resistance device. During this short period its characteristic curve would be changing in such a way as to eliminate any gap between itself and the resistance line. Reactance slows the flip by filling a current or voltage gap.

If R is the dynamic resistance of a resonant circuit it depends on frequency. The simplest sort, having one lumped inductance L and one capacitance C ,

in addition to inevitable resistance, is over-all resistive at only one frequency. If L and C are in series, the result is an acceptor circuit, which at resonance is a low resistance, and therefore likely to form an unstable combination with a current-controlled negative resistance. If indeed its resistance is lower than the negative resistance, continuous oscillation will take place at the frequency of resonance, for the interchange of current and voltage twice during each cycle causes reversal at the bends by a combination of the current-gap effect studied last month and the voltage-gap effect illustrated in Fig. 7. Because current is the thing common to both L and C in a series circuit, it is easy to remember (even apart from Fig. 3) that it is the appropriate kind for oscillation with current-controlled negative resistance.

Conversely, the parallel-resonant or rejector circuit, in which the same voltage is across both L and C , is the one for voltage-controlled negative resistance; it provides the high dynamic resistance which Fig. 1 shows is needed for instability. In spite of the appearance of Fig. 1, it is effectively in parallel with the negative-resistance device; the battery V_b is there simply as bias, and at the frequency of oscillation can be regarded as a short-circuit.

The dynatron and the point transistor with base bias resistance are not much more than technical curiosities, which would hardly justify the time we have given to them. But they typify the much more used devices in which negative-resistance is created by positive feedback. So the same principles apply to all kinds of positive-feedback circuits, which would be quite something even if we didn't remember that most *negative* feedback is positive at some frequencies.

Chromium Nitride Resistors

RESISTORS of small dimensions and very high stability are sometimes required for special types of equipment, and investigations at the Battelle Institute in America¹ have shown that it is possible to meet these requirements with resistors constructed of films of chromium nitride (Cr-N), or of chromium-titanium nitride (Cr-Ti-N). Films of these materials are deposited on ceramic bases by the vacuum-evaporation method and resistors of up to several megohms can be made having temperature coefficients of resistance less than 0.01% per degree C.

Nitriding is carried out at temperatures ranging from about 950°C to 1250°C and the films so treated exhibit wide ranges of temperature coefficient and of resistance per square.² Under certain conditions the temperature coefficient changes from positive to negative and the investigations point to the possibility of producing a wide range of resistors with near-zero temperature coefficients. The stability is greatly improved by mounting the resistors in sealed glass containers.

¹ Reported in the (American) *Journal of the Electrochemical Society* Vol. 102, No. 2, February, 1955.

² The normal expression for resistance of a conductor is given by:—

$$R = \frac{\rho \times l}{t \times w}$$

where R = resistance in ohms, ρ = resistivity in ohm-cm, l = length, t = thickness and w = width in cm. Resistance of films of constant t and $l = w$ is known as "resistance per square."

FEBRUARY MEETINGS

LONDON

4th. I.E.E.—“The importance of research in hearing and seeing to the future of telecommunication engineering” by Dr. E. C. Cherry at 5.30 at Savoy Place, W.C.2.

8th. Television Society.—“Scatter propagation and its application to television” by Dr. J. A. Saxton (D.S.I.R. Radio Research Station) at 7.0 at 164 Shaftesbury Avenue, W.C.2.

12th. I.E.E.—“The ultimate performance of the single-trace high-speed oscillograph” and “The design and performance of a new single-transient oscillograph with very high writing speed” by M. E. Haine and M. W. Jervis at 5.30 at Savoy Place, W.C.2.

13th. Radar Association.—“Automation: computer-controlled machine tools for small quantity production” by D. T. N. Williamson (Ferranti) at 7.30 at the Anatomy Theatre, University College, Gower Street, W.C.1.

14th. British Kinematograph Society.—“Photo-electronic aids to photography” by Professor J. D. McGee at 7.15 at the Royal Society of Arts, John Adam Street, Adelphi, W.C.2.

15th. B.S.R.A.—“Some recent developments in amplifiers” by F. Langford-Smith at 7.15 at the Royal Society of Arts, John Adam Street, W.C.2.

15th. Institute of Navigation.—“Navigation and traffic control over the north Atlantic” by D. O. Fraser at 5.15 at the Royal Geographical Society, 1, Kensington Gore, S.W.7.

15th. Physical Society and Institute of Physics.—“Acoustics in non-destructive testing” by Dr. R. W. B. Stephens at 6.30 at 47 Belgrave Square, S.W.1.

20th. I.E.E.—“The Stereosonic recording and reproducing system” by H. A. M. Clark, Dr. G. F. Dutton and P. B. Vanderlyn at 5.30 at Northampton Polytechnic, St. John Street, E.C.1.

21st. Television Society.—“The design of oscilloscopes for television laboratory work” by O. H. Davie (Cossor) at 7.0 at 164 Shaftesbury Avenue, W.C.2.

26th. I.E.E.—Discussion on “The analysis of waveforms” opened by A. Cooper and D. A. Drew at 5.30 at Savoy Place, W.C.2.

27th. Brit. I.R.E.—“Some applications of nucleonics in medicine” by E. W. Pulsford and N. Veall at 6.30 at the London School of Hygiene and Tropical Medicine, Keppel Street, W.C.1.

BELFAST

12th. I.E.E.—“Electronics and automation” by Dr. H. A. Thomas at 6.30 at the Engineering Department, Queens University.

BRISTOL

25th. I.E.E.—“Germanium and silicon power rectifiers” by T. H. Kinman, G. A. Carrick, R. G. Hibberd and A. J. Blundell at 6.0 at Electricity House, Colston Avenue.

27th. Institution of Production Engineers.—“Automation” by S. P. Woodley at 7.15 in the Small Lecture Theatre, University Engineering Laboratory, University Walk.

CAMBRIDGE

19th. I.E.E.—“Electronics and automation” by Dr. H. A. Thomas at 8.0 at Cavendish Laboratory, Free School Lane.

CARDIFF

20th. Brit. I.R.E.—“Radioactivity and its measurement” by E. W. Pulsford at 6.30 at the Cardiff College of Technology and Commerce, Cathays Park.

CHESTER

27th. Society of Instrument Technology.—“Computer-controlled machine tools” by G. S. Kermack (Ferranti) at 7.0 in the Board Room of Chester and District Hospital Committee, 5 Kings Buildings, King Street.

EDINBURGH

22nd. Brit. I.R.E.—“The field evaluation trials of electronic equipment” by H. Holmes and “The electronic manipulation of digits applied to statistics” by J. Kyles at 7.0 at the Department of Natural Philosophy, University of Edinburgh.

GLASGOW

14th. Brit. I.R.E.—“The earth satellite project” by P. H. Tanner at 7.0 at the Institution of Engineers and Shipbuilders, 39, Elmbank Crescent.

LINCOLN

28th. Institution of Production Engineers.—“Electronic control” by J. A. Stokes at 7.30 at the Ruston Club.

LIVERPOOL

14th. Brit. I.R.E.—“Radioactivity and its measurement” by E. W. Pulsford at 7.0 at the Chamber of Commerce, 1 Old Hall Street.

MANCHESTER

7th. Brit. I.R.E.—“Electronics in medicine” by R. F. Farr at 6.30 at the Reynolds Hall, College of Technology, Sackville Street.

12th. Society of Instrument Technology.—“Computing technique applied to measurement and control” by J. Wills at 7.30 at the College of Technology.

13th. I.E.E.—“Frequency-modulated quartz oscillators for broadcasting equipment” by W. S. Mortley at 6.45 at the Engineers' Club, Albert Square.

NEWCASTLE-ON-TYNE

18th. I.E.E.—“The use of transistors in radio and television” by Dr. A. J. Biggs at 6.15 at Kings College.

RUGBY

26th. I.E.E.—“The B.B.C. sound broadcasting service on very-high frequencies” by E. W. Hayes and H. Page at 6.30 at the College of Technology and Arts.

WOLVERHAMPTON

13th. Brit. I.R.E.—“An automatic system for electronic component assembly” by K. M. McKee at 6.0 at the Wolverhampton and Staffordshire Technical College, Wulfruna Street.

January Amendment

In place of the I.E.E. discussion on January 29th on the performance of d.c. amplifiers, mentioned last month, four papers will be read, including “A bridge network for the precise measurement of direct capacitance” by A. C. Lynch, and “A simple transformer bridge for the measurement of transistor characteristics” by W. F. Lovering and D. B. Britten.



sound equipment serves the world

Johannesberg Station, a key-point of South African Railways, informs its millions of passengers a year, through TRIX sound equipment, further proof of the reputation TRIX equipment enjoys throughout the world for all that is finest in perfect sound diffusion.



THE TRIX ELECTRICAL CO. LTD.
MAPLE PLACE, TOTTENHAM CT. RD.,
LONDON, W.1

Tel.: MUS 5817. Grams.: Trixadio, Wesdo, London.

RANDOM RADIATIONS

By "DIALLIST"

Guarantees

TO ME it has always seemed ridiculous that a new sound or television receiver should not be covered by a single comprehensive guarantee. As it is, there is a twelve months' set-maker's guarantee, but this does not cover the valves and cathode-ray tube for which there are separate three- and six-month guarantees. And there's another absurd point. The purchaser isn't covered at all for consequential damage caused by the failure of a particular component. Suppose, for example, that the breakdown of a capacitor damages several valves. Then the only free replacement to which you're entitled is that of the capacitor. The valves, you see, didn't blow up through any defect in their materials or manufacture. That kind of guarantee isn't worth having.

Twelve Months' Comprehensive

What I'd like to see is a comprehensive 12-month guarantee for the whole set covered by a single registration card, returnable by the purchaser to the manufacturer of the set. After all, the set manufacturers pay the piper and they can call the tune. If they stuck out for comprehensive twelve-month guarantees to them by valve and cathode-ray tube makers, they'd get them. I'm sure that the result would be increased sales. A hesitant customer is much more likely to take the plunge if he can feel that he knows exactly where he is with his set for the next twelve months. I've heard not a few people say that they won't buy a television set with its big array of valves and its cathode-ray tube until valve and tube makers show sufficient confidence in their products to guarantee them for more reasonable periods.

An Old Stager

THE OTHER day I was shown what must be one of the oldest wireless receivers still at work. Built in 1923 or 1924, it had originally five "R" valves—and what the output from its horn loudspeaker must have sounded like one shudders to think! It now has four 2-volt triodes and a power valve feeds a moving-coil loudspeaker. These are almost the

only alterations that have been made. Few repairs had been needed, I was told; but valve replacements had naturally been necessary at intervals. Still in its original home-made cabinet, it is a strange looking thing and vastly bigger than the five-valve set of today. I imagine that the sets—both sound and television—that we think so neat to-day will look just as cumbersome and as weird to those who see them in museums thirty odd years from now. Transistors will undoubtedly reduce the size of both, and flat cathode-ray tubes will slim television sets till they measure no more than five or six inches from back to front.

Direct or Projection?

THE FLAT cathode-ray tube will undoubtedly be perfected both in this country and in America. But are big tubes the best answer to the demand for big pictures? Myself, I very much doubt it. I've always thought projection the sounder and more scientific way of providing a large-sized television image. One wonders why it has not caught on better with the viewing public. It hasn't, for the number of projection sets seems to grow less at each succeeding Radio Show. Amongst its advantages are that, size for size, the projected picture is usually a good

deal less liney than the directly viewed. Then there's the difference in cost when a new cathode-ray tube is needed. I believe that what has hindered the progress of the projection receiver is that the optical system needs rather skilful adjustment and that servicemen capable of carrying this out are too few and far between.

Holme Moss or Emley Moor?

A FRIEND who has recently been in Leeds tells me that he heard one or two complaints of interference by the v.h.f. sound transmissions from Holme Moss with television programmes from the same station. This, if it's a fact, is rather a curious business. The television frequencies are 48.25 Mc/s (sound) and 51.75 Mc/s (vision). Those used for v.h.f. sound are 89.3, 91.5 and 93.7 Mc/s. Further, vertical polarization is used for TV and horizontal for v.h.f. One imagines, too, that the v.h.f. carrier frequencies must have been carefully chosen to avoid any chance of their interfering with television reception. Will any reader living in those parts and who can throw light on the matter please let me know? I'd have thought myself that interference would be more likely to come from the I.T.A. Emley Moor station, working in Channel 10



"WIRELESS WORLD" PUBLICATIONS

	Net Price	By Post
WIRELESS SERVICING MANUAL. W. T. Cocking, M.I.E.E. 9th Edition	17/6	18/6
GUIDE TO BROADCASTING STATIONS 1956-57. Compiled by <i>Wireless World</i>	2/6	2/10
RADIO VALVE DATA: Characteristics of over 2,500 Valves, Transistors and C.R. Tubes. Compiled by <i>Wireless World</i>	4/6	5/1
SECOND THOUGHTS ON RADIO THEORY. "Cathode Ray" of <i>Wireless World</i>	25/-	26/2
THE OSCILLOSCOPE AT WORK. A. Hass and R. W. Hallows, M.A. (Cantab.), M.I.E.E.	15/-	15/10
RADIO LABORATORY HANDBOOK. M. G. Scroggie, B.Sc., M.I.E.E. 6th Edition	25/-	26/6
ELECTRONIC COMPUTERS: Principles and Applications Edited by T. E. Ivall	25/-	25/9
RADIO INTERFERENCE SUPPRESSION: As Applied to Radio and Television Reception. G. L. Stephens, A.M.I.E.E. 2nd Edition	10/6	11/1
ADVANCED THEORY OF WAVEGUIDES. L. Lewin	30/-	30/10
ABACS OR NOMOGRAMS. A. Giet	35/-	35/10

A complete list of books is available on application

Obtainable from all leading booksellers or from

ILIFFE & SONS LTD., Dorset House, Stamford Street, London, S.E.1

(sound 196.25 Mc/s, vision 199.75 Mc/s). Holme Moss television aerials would mostly be designed for the mid-frequency, which is 50 Mc/s. It doesn't seem unlikely that they might be excited by a 199.75 Mc/s signal at short range and with 200 kW behind it.

Seeing Into the Past

WHAT an interesting pursuit the new branch of science, radio astronomy, must be. As Professor A. C. B. Lovell pointed out in his Kelvin Lecture it was the wartime advances in electronics in general and radio in particular that gave it a start. Though it was discovered in 1932 that radio waves from outer space were reaching the earth, it was not until 1950 that the first radio telescope came into action. Since then over 2,000 centres of radiation have been tracked down and this number is sure to be enormously increased when the giant telescope at Jodrell Bank gets to work next year. What I find specially interesting is that some of these centres are nebulae, which are all that is left of stars which once grew rapidly to abnormal brilliance and finally blew up. One of these nebulae is the remains of such a supernova recorded in A.D. 1054. Since it is 4,000 light (or radio wave) years away the explosion must have occurred about 3000 B.C. and the radiations now reaching radio telescopes began their long journey some time before the first stone was put into place at Stonehenge.

French TV System

THE MAP in the December W.W. showing the locations of European television transmitters gives one the impression that those of the French system are rather queerly distributed. Except for Paris and Bourges all the stations seem to be near the north coast and the northern and eastern frontiers. Many important towns must be very much in fringe areas, if they get a TV service of any sort. I'm sure there's some very good reason for the odd looking distribution of the transmitters, for the French authorities undoubtedly know their business and are determined to make television a success in their country. A possible explanation is that the map only takes account of stations that were actually in use last July and that what now look like gaps will soon be filled by transmitters still under construction.*

* R.T.F. plans to have some twenty stations operating by the end of 1957.—Ed.

"THE CHOICE OF CRITICS"

3 BRILLIANT SIGNAL-LAMP LENS

POLYSTYRENE LENS IN 3 SIZES

ONE-PIECE all-moulded in brilliant Polystyrene, with highly-plated ring-nut for fixing. These new Signal-lens bushes are available in three different sizes, each in a choice of five different transparent (red, green, blue, amber, water-clear) or translucent (red, green, blue, orange, white) colours.

Maximum working temperature is 50°C., from all sources of heat.

THE largest of the trio measures: Lens dia. = 1-3/16in., Bush dia. = 1-1/32in., Overall depth = 47/64in. List Nos. D.701/Colour (transparent), D.704/Colour (translucent).



THIS medium size model measures: Lens dia. = 27/32in., Bush dia. = 3/8in., Overall depth = 3/8in. List Nos. D.702/Colour (transparent), D.705/Colour (translucent).

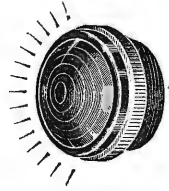

THE smallest size measures: Lens dia. = 19/32in., Bush dia. = 15/32in., Overall depth = 9/16in. List Nos. D.703/Colour (transparent), D.707/Colour (translucent).



FULL TECHNICAL DETAILS on these and all other Bulgin components are available in the latest edition of the **BULGIN CATALOGUE, 196/WW**, price 1/-, post free.



BULGIN

A. F. BULGIN & CO. LTD.
BYE-PASS ROAD,
BARKING, ESSEX

Telephone R1Ppleway 5588 (5 lines)

Crystal Jubilee

I SPEAK subject to correction but, to the best of my knowledge and belief, last year we should have celebrated the jubilee of the crystal detector which first came into use in 1906. As we all know, the crystal followed the valve which in the form of a diode rectifier was patented by Fleming on November 16th 1904. The crystal subsequently came into its own as it had a better characteristic curve than Fleming's diode and so was more sensitive.

I have little doubt that many of you veterans will tell me that I am all wrong and that you used a crystal rectifier long before 1906. What I really have in mind is its commercial use which in 1906 meant in ship and shore stations.

It is always difficult to fix a date for the first use of a particular technique. For instance it is generally agreed that the magnetic detector started to come into commercial use in 1902 when it rapidly displaced the coherer. But this particular magnetic detector was really only the first commercial version fathered by Marconi; the one with the continuously moving iron band. Rutherford used a magnetic detector of sorts to receive signals across Cambridge in 1897.

A Bucolic Bugbear

WRITING in a journal which circulates only among members of the radio trade, a dealer calls attention to the large number of battery sets in use in country districts which have no electric power supply.

Owing to the high cost of using dry cells continuously for L.T. supply, two-volt accumulators still flourish to a remarkable extent, and this dealer alone handles over 100 each week. I must confess that this rather surprises me as accumulators are messy things to have in the house but, worse still, have to be lugged periodically to the charging station and brought home with the week's shopping.

Surely the obvious thing to use as a substitute for a dry l.t. cell is the parent from which it sprang; namely, the ordinary wet Leclanché cell. It is true that this can be equally as messy as an accumulator but it does not have to be taken to the charging station. Whatever can be done by the small dry cell can be done very much more economically by a wet one as it only needs a new zinc electrode at very infrequent intervals.

Polarization is the bugbear of Leclanché cells, wet or dry, but the l.t. demand of a modern battery set

is so small that the depolarizer in the porous pot of the wet cell is more than ample to keep it going. Even if it were not, it would be an easy matter to rig up two cells and a change-over switch so that one could have a rest while the other was working.

Another advantage of the Leclanché is that it does not need a voltage-dropping resistance when used with 1.4-volt valves as does a 2-volt accumulator.

Teledynamics?

THE EDITOR and I have, in recent months, both written about the transmission of power by radio. No doubt it will be many years before serious consideration is given to this question. But one day power transmission by wireless will "arrive" and we ought to coin a proper portmanteau word for it. We don't want to be caught napping as we were in the case of television and have a horrible hybrid word like "dynamission" foisted on us by the lay press.

I cannot think of a good and correct word offhand; all that suggests itself is "teledynamics." While correctly derived, this word doesn't suggest the idea of radio transmission any more than "telearchics" suggests radio control.

I am not too fond of any of these "tele" words in any case. The word "telephone" does not, for instance, suggest the idea of transmission by wire or by any form of electrical energy. It would be equally correct to apply the word "telephone" to a speaking tube.



Newnham Nymph

Now it is up to some of you classical boffins from Balliol to lend me a hand and justify your existence. I feel sure the "Greeks had a word for it" but it needs a lot of excavating

by some of the Bodleian boys. However, it is really women who never seem to be at a loss for words, and so perhaps I had better call on the Newnham nymphs for help in this matter.

Destaticizing

I HAVE previously denounced as mere superstition the dainty little trailing chains which many motorists used to destaticize (what a word!) their car bodies and so eliminate the travel sickness to which many people are prone. If it be other than superstition why is it that railway travellers are not immune from sickness, for few things are more firmly earthed to the rails than a railway carriage? Why, too, don't cyclists suffer from sickness for their machines are as much insulated from the road as a car?

A correspondent has, however, put forward an argument which to him seems to prove that the destaticizing chain is really effective in preventing travel sickness even in cases where the psychological effect of auto-suggestion can be ruled out.

It appears that a dog owned by a colleague of my correspondent, which has always been prone to car sickness, has been completely de-nauseated by the fixing of one of these dangling chains. Therefore, argues my correspondent, the chain must work by physiological rather than by psychological means as the dog does not know that its sickness is caused by ambient static which the dangling chain removes.

Now whatever our views about the *modus operandi* of telepathy it is well known that a dog readily picks up the mood of a human being, and more especially that of its master. It is also well known that this phenomenon is due, not to telepathy, but to teleolfaction. Human and other beings exude a certain amount of perspiration even in an arctic temperature, and the odour of the perspiration varies with the emotions.

We have all heard of the "odour of sanctity" and Shakespeare speaks of the "disodour of impiety." There is, in fact, a characteristic odour associated with every emotion, and a dog, with its keen sense of smell, sorts them out. Thus a strange dog is apt to attack people who are afraid of it as they emit an odour of fear.

Obviously my correspondent's colleague, who owns this particular dog, has great faith in the dangling chain and he must, therefore, exude a strong odour of faith—not necessarily akin to the odour of sanctity—which his dog readily picks up.