

HALF A CENTURY

IN 1911 the business and profession of wireless communication was already established, but as yet it had made little impact on the daily lives of most people. There was a certain novelty in sending a telegram "via Marconi" and a few amateurs dabbling with spark coils and crystal and electrolytic detectors made a welcome diversion from lantern lectures and microscopy at the local literary and scientific society. But the seeds of future developments had germinated. Every day more ships were being fitted with wireless, and more amateurs were proudly passing their headphones to admiring friends to listen to the musical morse of Clifden or the growl of Eiffel Tower and Poldhu.

Until then technical information had been scattered in occasional articles in the electrical journals and in one or two papers read before the learned societies. Now it was decided that there was sufficient interest to support a journal "the aim of which will be to acquaint the reader with the latest possibilities of this most marvellous invention." Such was the success of the *Marconigraph* that two years later it was decided to give it a new format and a new title in keeping with its wider circulation. In the first editorial of the new series we said, "The *Wireless World* will still be the medium, as was the *Marconigraph*, for the interchange of ideas concerning the further scientific and commercial development of wireless telegraphy, with its bearing upon national and economic interests. But these long words do not mean that we intend to take up the standpoint of a dry and educational science. Our Magazine is to be popular, and while the information we shall print will compel the attention of the scientist, it will not be beyond the scope of the general public."

If at times we seem to have become more complex it is because we reflect the growth of our subject, which even in its beginnings called for more than a little application to gain mastery. We invite those who doubt this to turn up some of our earliest issues (e.g., the series on aerial capacitance

by Professor G. W. O. Howe in 1915). While many of our articles have been addressed exclusively to the professional quite as many have been prepared specially for the beginner who may be at the start of his career as a radio engineer or technician or just interested in the subject as an amateur. The dividing line, if indeed one exists, is hard to draw. Many of our readers who earn their living by research on semiconductors or development on microwaves find relaxation as amateur transmitters or high-quality sound enthusiasts. We welcome them all as readers and take this opportunity of thanking them for their sustained interest, which as our recent questionnaire has shown, more often than not is of long standing.

The entity and character of a journal is something which is difficult to define in words. It transcends all outward forms of print and styling; it cannot be detected in the contents of individual articles; it exists as like-minded thought and a community of interests between readers and staff. We are all of different ages, have divergent personal interests and while retaining our independence are prepared to argue, to listen and to learn—all with one object: as far as this journal is concerned to keep the record straight.

Looking back we pay tribute to our predecessors in office, to past members of the staff, to our contributors and to all those whose ability and loyalty have laid the foundations upon which we build. Looking to the future we shall strive to improve our journal as the medium of communication between all whose vocation or interest lies with radio and electronics, to serve as a forum for discussion, as a medium for enlightenment and exposition, and as a bulletin for news of the world of wireless.

"This then is our policy: to be of use and interest to our readers, and through them to be a factor for progress." These words are quoted from Volume 1, No. 1 of *Wireless World* and we can find no reason for altering them today.

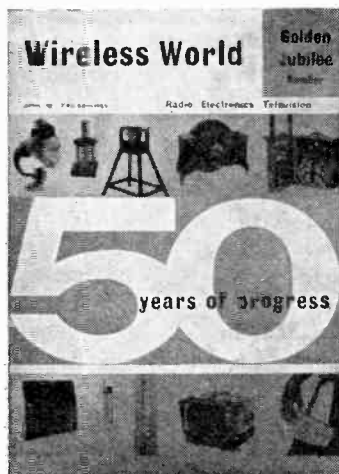
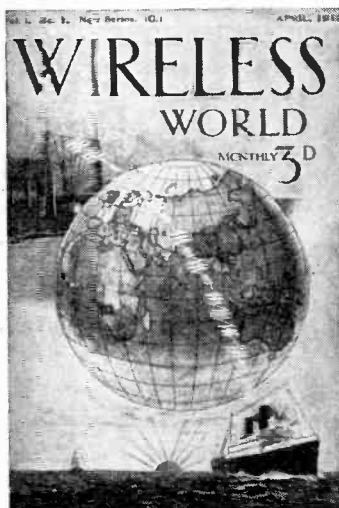

SINCE THE

50

Years of Progress As Seen Through Our Pages

THE STATE OF THE ART IN **1911**

THE Edwardian age into which *The Marconigraph* was launched was less prone than is the Neo-Elizabethan to the unquestioning acceptance of scientific marvels. Many people still looked upon wireless telegraphy as “against Nature”; as something akin to a music-hall trick. That attitude of mind was certainly not discouraged by wire telegraphy and submarine cable interests, with whom we were to remain in bitter competition for many years. By way of counter-attack, we made great play of the fact that the so-called “KR factor,” which limited the speed of cable transmission, did not apply to us. High-speed wireless transmission—which then meant about 60 words per minute—had already been demonstrated experimentally, but the volume of traffic on offer was generally not great enough to encourage its commercial use.

Whatever the reason may have been, wireless telegraphy had hardly made spectacular progress during the first dozen years of its existence. When we began publication there were, according to official figures published later, a mere 1,740 licensed land and ship stations in the whole world.

But that understates the position rather seriously. The United States had not ratified the International

Convention and had no licensing system; thus the true number of her stations cannot be ascertained. For once, America had made a slow start in taking up a scientific innovation; when the first wireless-equipped ships sailed from Europe to the New World there were no coastal stations in the North American continent with which they could communicate. But America was soon to catch up, and by 1911 probably had a greater number of stations than any other single country. Going by the few figures available and working backwards from the time when licensing came in, it is fairly safe to guess at a round 1,000, or something not far short of it. Thus the world total of stations in 1911 was over 2,500. The total number of people gaining their livelihood in wireless, from Mr. Marconi himself down to the humblest messenger boy, could hardly have exceeded 8,000.

Though the commercial growth of wireless may have been disappointingly slow, technical progress had been quite impressive. An old-timer dating back to 1911 might make out some sort of case for claiming that the effectiveness of the gear of his period had increased as much since 1897 as it has done between 1911 and the present day. Be that as it may, he would be on

Wireless World BEGAN

Wireless World, the first radio journal, appeared in April, 1911, as The Marconigraph. The present title was assumed two years later. We were originally published by the Marconi Company and circulated largely among engineers and operators, though from the start there was a public readership. We became an independent journal 36 years ago. This review traces the significant advances in radio and electronics since we began. Except in the introductory section, the material is taken entirely from our own pages. In the introduction an attempt is made to give the reader a glimpse of "what everybody knew" in 1911.

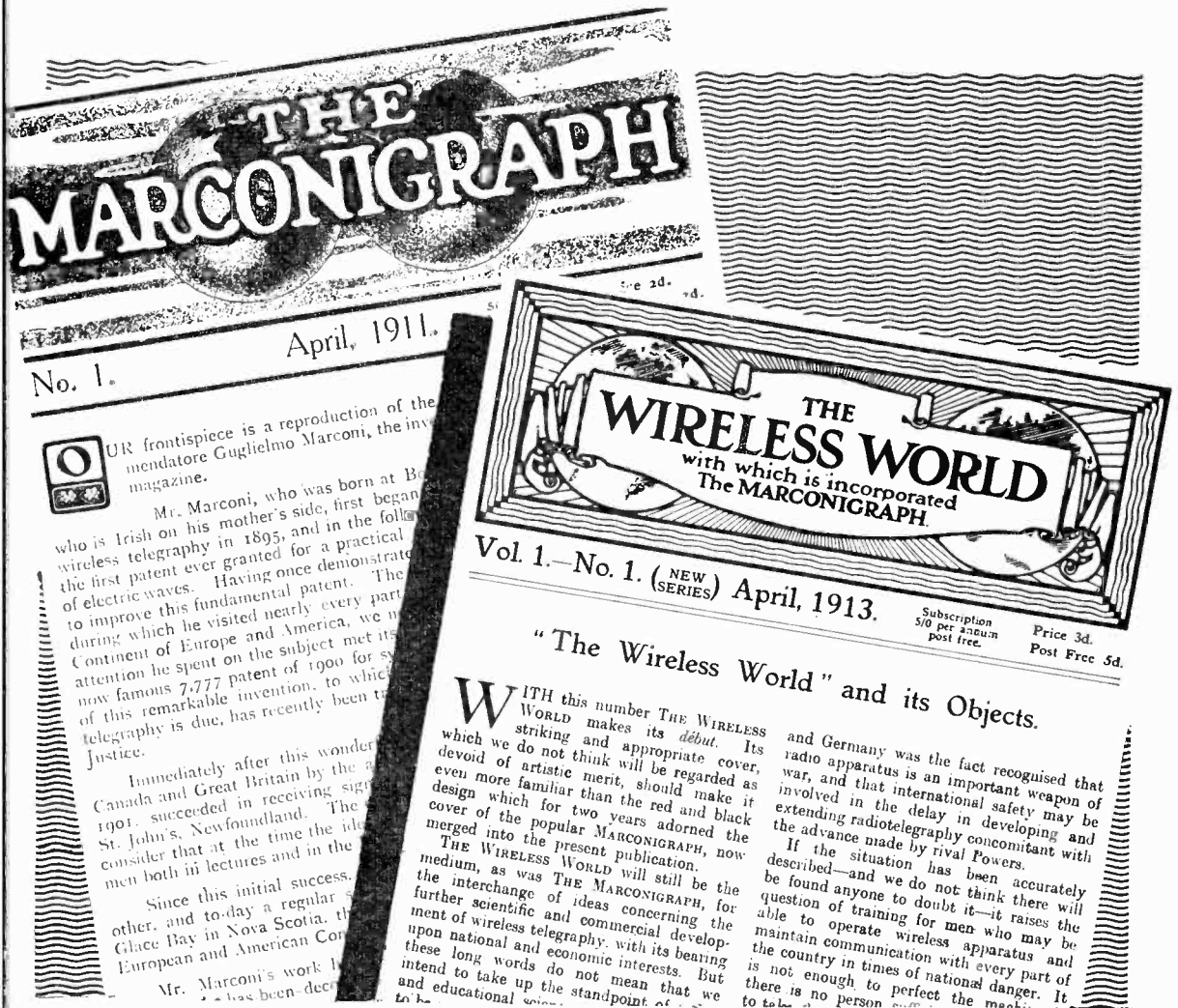

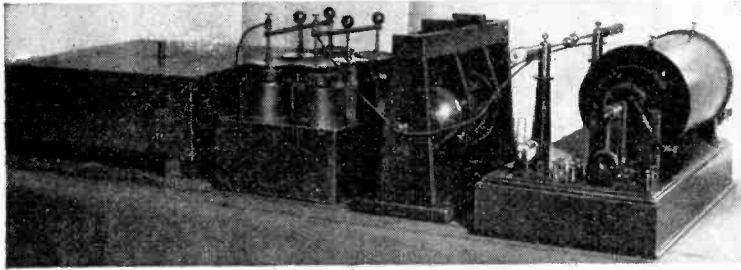

A "coil set"; the kind of transmitter that was going out as we came in. Right to left: induction coil, spark gap, "battery" of Leyden jar condensers, "jigger."

pretty sure grounds in going on to claim that by 1911 the foundations of nearly all modern techniques had been laid and the majority of the great basic inventions had been made. Practitioners of the art certainly did not look on themselves as being in the Dark Ages. They had already seen great technical progress and were full of confidence for the future. To them, it was a kind of Elizabethan age, when everything was bright, new and exciting.

Many of the inventions that had been made were waiting—and some had to wait for many years—for the means to put them usefully into practice. Christian Hülsmeyer's radar pulses, first suggested by him in 1904, had to wait 30 years for the means of generating them and usefully detecting their reflections. Oliver Lodge's moving-coil loud-speaker looks, in the patent specification drawing of 1898, surprisingly like the instrument of today, even if the "hi-fi" enthusiast would hardly approve of his diaphragm or its suspension. But valve amplifiers capable of working moving-coil speakers did not appear until 20 years later.

Fleming's diode, which we used to call, rather confusingly, an oscillation valve, was already ancient history, and was not especially esteemed as a signal rectifier. De Forest had added a grid in 1907, but his triode had made no impact. Probably fewer than five per cent of our early readers had ever heard of it and there was no mention of triodes in our pages for the first two or three years. The triode remained in obscurity until the discovery of regeneration caused many workers to concentrate their efforts on its improvement. Those efforts were probably triggered off by von Lieben's work on the amplifying triode in 1910-11.

"Tele-vision" (generally so

printed) was a word that appeared surprisingly early. Nipkow had enunciated the basic principles of scanning in the nineteenth century, but few seemed seriously to expect that "moving pictures by wireless" would be achieved. One of the exceptions was Campbell Swinton, a versatile engineer and wireless enthusiast who had already forecast that, if the difficulties were ever to be overcome, it would be by means of "the weightless cathode rays" of the Braun tube, the forerunner of the c.r. tube of today. Magnetic recording—on wire, not coated tape—was already known and had been used for the recording of high-speed signals.

Transistors? Well, hardly. But oscillating crystal circuits had been devised by Dr. W. H. Eccles, one

of the "founder members" of wireless technology whose name recurred constantly in our pages for many years. In another sphere, he was one of the first to accept and interpret Heaviside's theory of a conductive layer in the upper atmosphere as an explanation of observed phenomena in long-distance wave propagation. For a long time to come there was a tendency to ignore or even to scoff at Heaviside's theory; his American co-worker Kennelly had even less recognition on this side of the Atlantic.

In Britain the art we practised was always called "wireless." The official international word "radio" had been introduced some years earlier but had had a chilly reception. It did not trip easily off English tongues; worse, to use it was considered "non-U" and aping the foreigner. In fact, though, most nationalities still preferred their own versions of "wireless": *sans fil*, *drahtlose*, *sin hilos*. But in Germany they soon began to show a preference for the word *Funk* (spark) which still survives strongly in *Rundfunk* (broadcasting).

Naturally enough, wireless had already produced its own jargon. Equally naturally, many of the earlier examples have now disappeared, some of them frozen out by changing techniques. One of the queer words was "jigger" (r.f. transformer for coupling the closed circuit, transmitting or receiving, to the open aerial). The derivation of this term is obscure and has apparently been lost in the mists of time. Maurice Child, in a historical lecture in the early 20s, admitted his inability to trace it. "Billi" is easier; it was a small variable condenser reputed to have a capacitance measured in billionths of a farad. Though by international agreement wavelengths were measured in metres, the foot still served occasion-

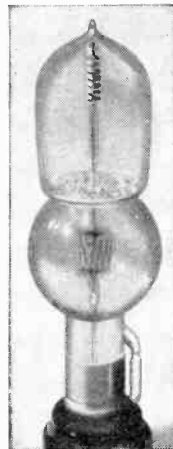

Photo: Deutsches Museum, München.

An historic valve—the Lieben-Reisz triode of 1911.

ally as the unit. It had not been so long ago that only two wavelengths were in use, officially for merchant ship communication, but in fact for other purposes as well: Tune A, 1,000ft and Tune B, 2,000ft—quite near enough to 300 and 600 metres for the order of accuracy then prevailing. Whether chosen by luck or judgment, Tune B, the more popular, was in fact an excellent general-purpose wavelength for the techniques of the times. The foot (length of wire used in winding a coil) sometimes served also as a unit of inductance!

The Postmaster-General's control of all wireless activities in Britain had been firmly established by the Wireless Telegraphy Act of 1904. Even before that date the Post Office had quietly assumed power over us by virtue of the monopoly in telegraphy conferred on it by Disraeli in Victorian times. This control may at times have seemed somewhat heavy-handed; indeed, *Wireless World* has on many occasions throughout its life been at odds with the Post Office over allegedly restrictive practices or other departures from rectitude. But we must remember that the Post Office, as one of its historians has said, "is not just another Department." It functions under a long-established tradition of providing a public service, first in carrying the mails, then in transmitting telegrams and later in running a telephone service. In return, Parliament has granted certain monopolies and privileges, which have always been jealously guarded. Each successive development in wireless must have seemed to the official mind to threaten serious encroachment on these monopolies and it is small wonder there have been occasional bunglings and examples of over-cautiousness. However, it is a pleasant thought that Post Office control has generally been benevolent and beneficent.

Apart from the exercise of his monopolistic powers, it was (and is) the duty of the Postmaster-General to ensure the observance of international regulations. In 1911 we were governed by the Convention of 1906, to which nearly all nations had adhered. The United States was an exception; neither had she ratified the Convention (was that a manifestation of the Monroe Doctrine?) nor had Congress as yet passed any law to regulate or control wireless communication. America was indeed the land of the free. But, according to stories—perhaps exaggerated—filtering across the Atlantic,

jungle law prevailed. Deliberate jamming of competing stations was commonplace and powerful stations shouted down the weaker. And there was nothing to protect the secrecy of messages. According to the folklore of the time, submarine cable interests intercepted telegrams sent by the Marconi transatlantic station at Glace Bay, Nova Scotia, and published a selection of them—reputedly the most scandalous—as advertisements in New York newspapers. They are also said to have published intercepted messages relating to interruptions in communication, such as "stand by for three hours; atmospherics too bad," thus hoping further to discourage potential users of the new and then struggling wireless service. This latter

Both arc transmitters and rotary r.f. generators capable of producing continuous waves had been developed, but in the absence of valves the problem of modulation was indeed difficult. Water-cooled and liquid jet microphones, inserted directly in the aerial circuit had been used in some of the experiments.

For telegraphy, spark transmitters were almost universal. A big station of the period was an impressive affair; the sight, and still more the sound, of tens of kilowatts being dissipated in a crashing oscillatory discharge was something not easily forgotten. There was even a strong characteristic smell, generally referred to as "ozone". All the so-called "systems" were basically similar; the circuit arrangement,

Basic circuit of spark transmitter.

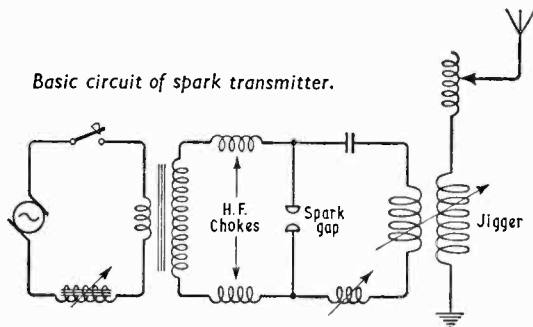

kind of interception was eventually circumvented by the use of code words for inter-station messages relating to interruptions and similar matters.

Some support for the truth of these stories comes from the fact that American legislation, when it eventually came, was not particularly onerous in most respects but imposed severe penalties for deliberate jamming and failure to observe secrecy. As things turned out, the American free-for-all had worked remarkably well in the early stages. No doubt most of the stations did in fact establish a tacit *modus vivendi* with their competitors. But control was bound to come sooner or later; in the event, it came sooner than expected, and for a reason that nobody could have foreseen.

Wireless telephony had already been accomplished experimentally when we began publication, but was as yet of no practical significance.

shown in the accompanying diagram, was simple enough. The a.c. supply, of 50 or 60c/s, was stepped up to 15 or 20kV, an iron-cored choke being inserted in the transformer primary circuit to bring it into resonance with the alternator frequency. The condenser of the closed oscillatory circuit, charged through protective h.f. chokes, discharged itself through a spark gap, the electrodes of which, in all but the most up-to-date sets, were stationary, though adjustable as to distance. The closed circuit was coupled to the open aerial through a double-wound "jigger" or an auto-transformer.

These fixed-gap sets gave a low-pitched, irregular tone distinguishable with difficulty from atmospherics and radiated heavily-damped wave trains, due to interaction between closed and aerial circuits. The "rotary discharger" sets which were just being introduced were a great improvement in both these respects. In the most

highly developed form the rotary electrode, mounted on an extension of the alternator shaft, carried a number of projecting studs arranged to give a spark for each half-cycle of the supply frequency; this had now been increased to several hundred cycles per second. Thus a clear high-pitched note was produced, and, as the primary circuit was opened after a very short interval of time, interaction was reduced and there were more persistent oscillations in the aerial circuit.

Transmitters fed from alternators were known as "power sets" and were mostly fairly up-to-date. But there were in 1911 many relics of the not-so-distant past with induction coils drawing their supply from accumulators or d.c. mains. These were mostly fitted in merchant ships but the British Post Office station at Malin Head in the remote North-West of Ireland is thought to have had at this time a coil set worked from an accumulator battery charged from banks of primary cells.

Input power of the typical and more modern transmitters of the period for ships and coastal stations was generally between one and three kilowatts; anything more was considered high power. A fair number of point-to-point and special-service stations used as much as 30kW; anything more was quite exceptional. The lower-powered stations seldom achieved a daylight range of much over 300 miles, depending on their aerial height.

The most common type of receiver used the Marconi magnetic detector, a rugged and reliable but relatively rather insensitive device. It depended for its action on hysteresis changes in an endless soft-iron-wire band moved by clockwork through a coil carrying the received signal current. A magnetic field was provided by a pair of permanent magnets and a secondary winding, concentric with the r.f. coil, was connected to a pair of telephones. Unlike other detectors, the magnetic was a current-operated device and

the associated three-circuit tuner had circuits with a low L/C ratio.

The only other kind of detector in widespread use was the crystal rectifier, the combinations most favoured being carborundum-steel, zincite-bornite and silicon-gold. Crystals were almost always used with two-circuit tuners having variable coupling between primary and secondary. A few stations had Fleming diodes.

Work on rotary r.f. generators had been going on for some years, but they had barely reached the stage of commercial use. The fact that an electric arc, shunted by a tuned circuit, could produce continuous oscillations had been known for some time. This had been turned to practical use by enclosing the arc in a chamber filled with hydrogen or alcohol vapour and subjecting it to a strong magnetic field. A small number of arc stations were in operation, mostly in America, but efficiency was low and continuous waves had little advantage until heterodyne reception became possible. The mechanical interrupters ("tickers") used in early c.w. receivers did not allow aural discrimination between signals and atmospherics.

Constructionally, the gear of the period tended to follow contemporary scientific instrument practice, with lacquered brasswork much in evidence, especially in Britain. Nickel-plated finish was more popular on the Continent and in the U.S.A., where ceramic insulants tended to be more widely used. Ebonite was, however, the most favoured material; plastic mouldings were virtually unknown. The concept of a "packaged" station had not arrived; the majority of transmitters and receivers consisted of a collection of units mounted where convenient and then wired together. But complete single-unit receivers were fairly common.

Some of the older stations used tinfoil-coated Leyden jars as transmitter condensers (the "jar" still did occasional duty as a unit of capacitance, but not in our pages). There were more modern tubular versions with sputtered or electrically deposited metal coatings on superior glass. Oil-filled condensers with metal plates and sheet-glass dielectric were perhaps the most common. Receiving variable condensers often had ebonite dielectric.

By far the most important application of wireless was for marine use,

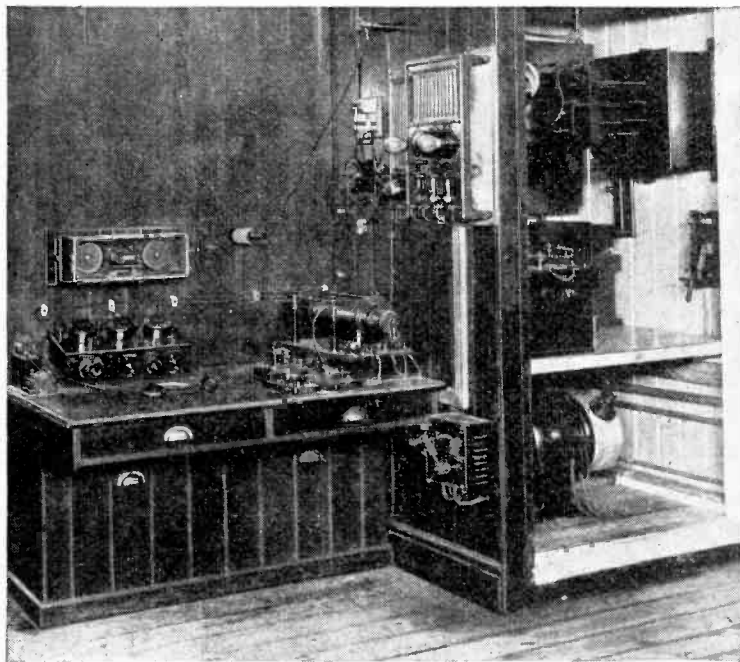

Typical Marconi ship's wireless installation of the period showing (left) receiving tuner with magnetic detector on bulkhead above it; (centre) emergency spark-coil transmitter and (right) 1½ kW rotary converter and spark gap of the main transmitter with (above) boxed coils of "jigger" and aerial tuning inductances.

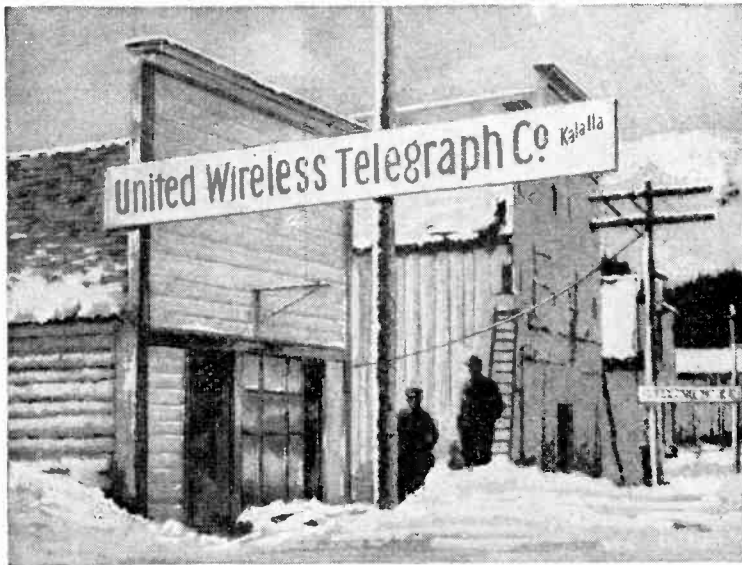

Log cabin station typical of those used by North American miners, trappers and fishermen to keep in touch with civilization.

The French military station on the Eiffel Tower, with its fixed spark gap and 25-c/s a.c. supply ("one spark for a dot and three for a dash") was known throughout Europe for its time-signal service. Thanks to the exceptional height of aerial, very long ranges were achieved, though the signals were often quite difficult to read through X's. The German stations of Nauen and Norddeich were also well known. Most of the high-power transmitters worked on wavelengths around 2,000 metres but the transatlantic station Clifden and Glace Bay were on about 6,000m.

Commercially, the Marconi Company and its associates throughout the world were in a dominant position, if only by virtue of the patent position. In our very first issue we reported a successful action for patent infringement against the British Radio Telegraph and Telephone Company which did much to consolidate that position. Marconi's personal claims as the originator of wireless telegraphy had been hotly challenged for a dozen years or more. But, now the smoke has cleared away, it is not difficult to see that those claims were fully justified. He may not have contributed any great fundamental invention but, put in the simplest possible way, he had "made it work." The last word in the controversy had in reality been said as long ago as 1897, when the Editor of the *Electrical Review*, in answer to the rhetorical question "What did Marconi invent?" said, quite simply, "the elevated electrode." A prolonged subsequent correspondence in the pages of the journal failed to establish any valid claim to the anticipation of Marconi's invention of the aerial. It is clear enough now that an elevated aerial, plus an earth connection, was all that was basically necessary to turn Hertz's transmitting oscillator and Branly's receiving coherer at one step into a communication system with a useful beyond-the-horizon range. Subsequent detail improvements were not so difficult, but especial credit should be given to Lodge, whose "syntonic jars" experiment of 1889 had paved the way for syntony or tuning, without which wireless could never have got very far.

The race for priority had been close run and several rivals were breathing hard down Marconi's neck for the golden prize. And golden it turned out to be. When the young Marconi, in his early 20's, formed his company in 1897 he received £15,000—in golden sover-

both in merchant ships and the navies of the world. Next came coastal stations for working with the ships. These were often sited on prominent headlands; a relic of the days when ranges were even shorter than in 1911. A few strategic naval and military stations, mostly of relatively high power, had been erected.

With the exception of the transatlantic service (of which more later), wireless had so far made little progress in its competition with land-line and cable for point-to-point work. There were, however, a certain number of stations providing a telegraph service for isolated communities in cases where a wire connection was uneconomic. In particular, the so-called log-cabin stations on the North American continent allowed local miners, trappers or fishermen to keep in touch with the outside world. A few of the early point-to-point stations, working at distances well beyond normal daylight range, provided a rather erratic service by taking advantage of night-time propagation conditions. Indeed, what might be called the "Heaviside bonus" was extremely valuable in the early days, particularly to ships. With its help, extraordinary ranges were attained with some consistency, especially outside the equatorial atmospheric belt. Atmospheric, or X's, were the

great enemy. X-stoppers, optimistically so-called, had already appeared, but no real solution was in sight. About the best that could be done was to use pairs of crystal detectors working in opposition as limiters.

Special-purpose equipment for military and similar uses was already being designed and wireless had managed to stagger into the air in both lighter- and heavier-than-air machines.

Prominent among the handful of famous stations of the time was Poldhu, in Cornwall, whose main task, together with its counterpart Cape Cod, U.S.A., was to provide a Press Service for the big liners which already printed daily newspapers on board. Poldhu was the first a.c.-operated "power set," as distinct from an instrument-maker's job powered from an induction coil. It had been used by Marconi just after the turn of the century for the first transatlantic experiments. Dr. J. A. (afterwards Sir Ambrose) Fleming had been called in to do the original engineering design. Fleming is mainly remembered for his invention of the diode, but he has an equal—perhaps even greater—claim to fame as the first of the wireless engineers. Incidentally, he was the author of the first severely technical article (on r.f. resistance measurement) ever to be published in *The Marconigraph*.

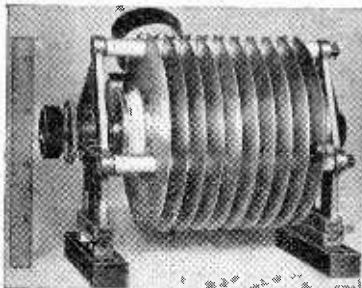

Construction and electrical characteristics of the Telefunken quenched spark gap (based on Figs. 8, 10, 11, page 155 of Telefunken Zeitung, Vol. 26, No. 100)

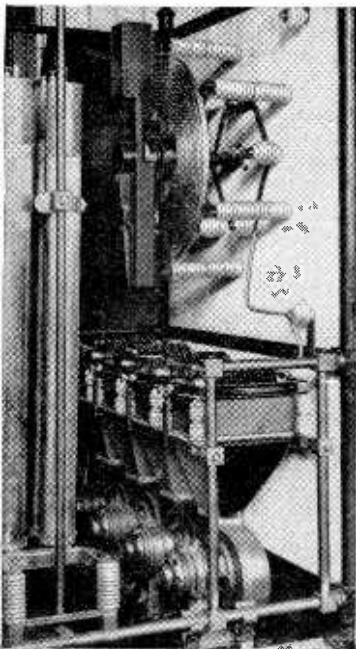
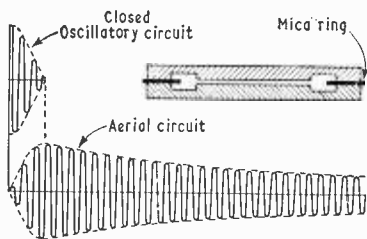

Air-blast cooling of multiple quenched spark gaps in a Telefunken high-powered transmitter.

eigns, not depreciated paper pounds—and £60,000 in shares, which gave him a controlling interest. He was no guinea-pig director; at the time we began he was playing a dominant part in technical development.

At that time Marconi had no significant competition in England but his American company had to struggle against the United Wireless Company which controlled some 500 stations. But, in a year's time United Wireless was to be absorbed after admitting the validity of the Marconi patents. The real and most serious competitor, both commercially and technically, was the Telefunken Company in Germany, an amalgamation of several German wireless interests.

Telefunken had produced a distinctive and extremely effective spark transmitter of which the main feature was a multiple spark gap made up of a number of silver-faced copper discs with deep cooling flanges separated by thin mica rings. In the standard 2½kW set there were eight series-connected gaps. Thanks to the rapid dissipation of heat, excellent quenching of the primary circuit oscillations was secured, with wave-trains of high persistence in the aerial circuit. An alternator frequency of 500c/s gave a spark frequency of 1,000; the high-pitched note of Telefunken transmitters was quite distinctive. Efficiency was high; probably over 60%.

The Telefunken receiver had a tuned aerial circuit variably coupled to a semi-aperiodic secondary shunted by a crystal detector and headphones. An alternative type of set, giving higher selectivity, had an intermediate tuned circuit. Clip-in interchangeable coils were used. The detector, a sealed cartridge usually with a silicon-gold combination, was interesting as a kind of forerunner of the modern crystal diode.

Germany's contribution to wireless development had been acknowledged when Ferdinand Braun shared with Marconi the Nobel Prize for physics in 1909.

In the early days the transatlantic station at Clifden, in the wilds of Conuemara, was the wonder of the world of wireless. And rightly so; there was nothing remotely approaching it, either in technology or performance, except its communicating station at Glace Bay, Nova Scotia, which, being more remote, was less in the limelight. Marconi himself gave a detailed description of Clif-

den, which had recently been rebuilt, in a lecture to the Royal Institution, reported in our first volume. This fantastic station was unique in being powered by d.c., drawing 300kW from a 6,000-cell accumulator battery, "the largest of its kind in existence," which, when fully charged, gave a voltage of 15,000. Charging of the battery was by three series-connected high-voltage generators, the prime mover being a steam engine. The six boilers were fired with peat, brought by a light railway from the adjacent bog. Still more fantastic was the closed circuit air-dielectric condenser; the metal plates were spaced a foot apart and this component—the first to which the term "low-loss" was applied—needed an enormous shed to house it. The rotary spark gap was run at a speed giving a sparking rate of 500 p.s. As the rate was independent of load, the note was exceptionally pure.

For the year to April, 1911, it was proudly claimed that 812,200 words of paid traffic had been pumped across the Atlantic. That would sound pitifully small to the manager of a modern communication circuit, but

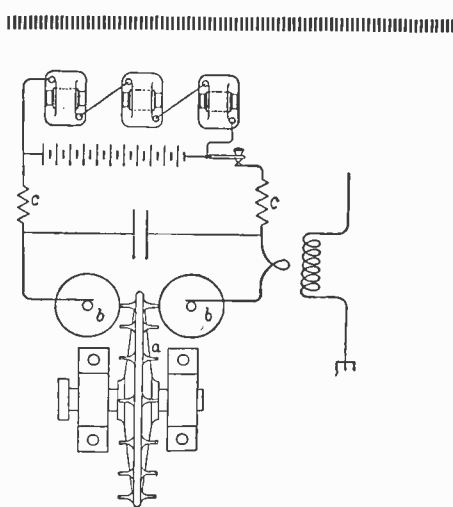

DISC DISCHARGER
CONTINUOUS CURRENT

Circuit diagram of the Clifden "d.c." transmitter.

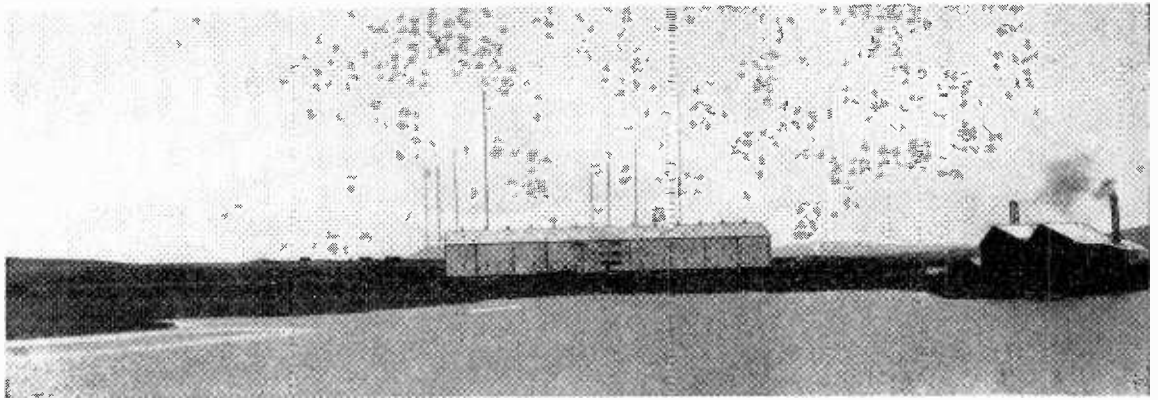

General view of the transatlantic high-power spark station at Clifden, Connemara. On the right is the peat-burning power house.

was probably a great improvement over that achieved with earlier apparatus. Detailed records are lacking, but in the Marconi archives there are some figures relating to the period beginning October, 1907, when a limited public service had been opened. Traffic was then running at the rate of a mere 300,000 words a year and average delays ranged from 2½ hours at best to over 14 hours.

And—supreme humiliation to wireless men—well over 7,000 words had to be handed over for transmission by cable. Apart from the humiliation, that involved a dead financial loss of 4d a word: the “via Marconi” service was cut-price.

We do not know what were the delays and “cablings,” as they were called, in 1910/11, but it seems certain that the new apparatus just

described had brought about a great improvement in communication. Independent testimony given a year or two later suggested that average delays did not exceed those of the cable. But highly detailed signal-strength curves shown in Marconi’s 1911 lecture make it appear that communication was liable to fail for a few hours nightly at times when X’s were prevalent. Still, it is fair to

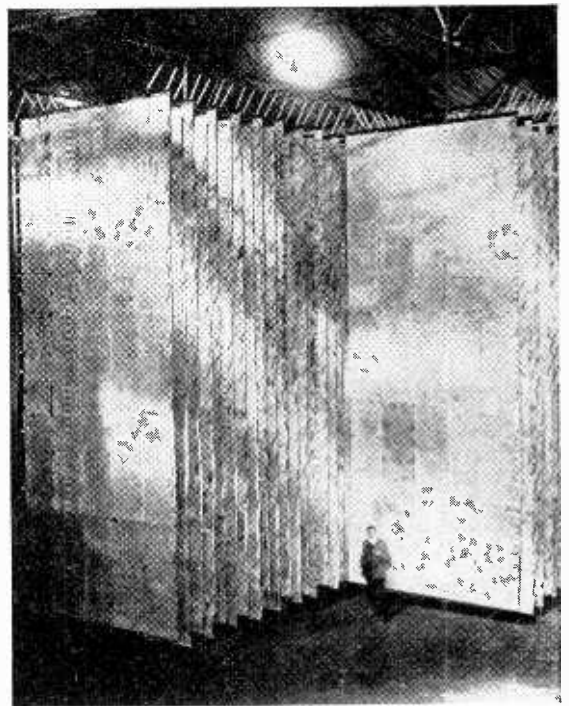
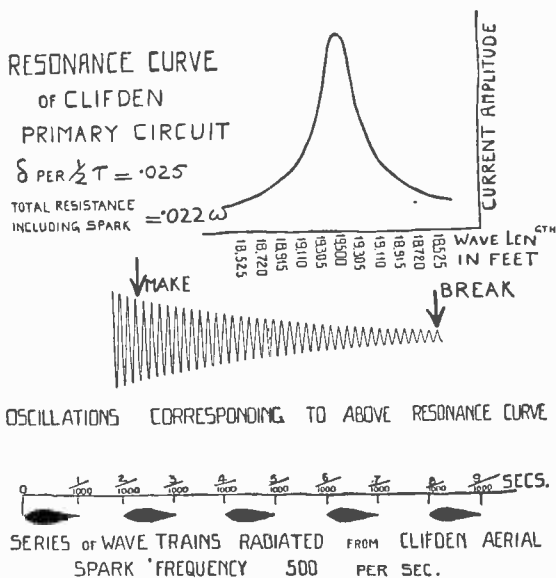

Characteristics of the Clifden transmitter. (From Marconi’s Royal Institution Lecture, June 2nd, 1911.)

Air-dielectric condenser of the closed circuit at Clifden.

say the Atlantic had been conquered at last after many failures and disappointments. The epic struggle to get consistent signals across had started from the Canadian end* eight years earlier, at a time when nothing was known about long-distance propagation; the engineers did not even know on what wavelength they were transmitting! Countless changes in circuitry, power and aerial arrangement had been made. Glace Bay station had even been shifted to a different site.

Clifden came to a sad end in "The Troubles" of 1922, when the station buildings were burned to the ground. Still, it had nearly served its time and a radically new long-distance technique was soon to emerge. The station has no memorial, though, by a strange coincidence, near the site is a commemoration stone to the flyers Alcock and Brown, who crash-landed there after conquering the Atlantic through a different medium.

* The Canadian government had subsidized the Glace Bay station to the extent of \$80,000.

1912

A CATASTROPHE which stirred the minds of men—and still does so—was the sinking of the *Titanic*. That great liner, believed to be unsinkable, struck an iceberg on her maiden voyage and sank in a few hours. Over 1,500 lives were lost, but some 700 were saved by ships summoned by wireless.

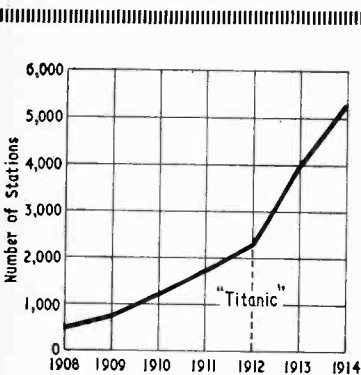

Increase in the number of the world's licensed stations between 1903 and 1914. (Based on data from the International Radiotelegraphic Bureau, Berne.)

That "epic tragedy of the sea," as we called it, was to have far-reaching effects. In earlier shipwrecks lives had been saved by wireless, but the part it had played in the *Titanic* disaster fired the public imagination; no longer did anyone doubt its value. America quickly passed a law to regulate wireless communication and, at long last, ratified the International Convention. Wireless men had become benefactors of humanity and, if our pages can be taken as reflecting their attitude, felt they "had never had it so good." Indeed, over-confidence began to creep in.

A grandiose, and what now seems over-optimistic, "Imperial Wireless Scheme" for linking the units of the British Empire was planned and a contract between the Postmaster-General and the Marconi Company was signed in July. A few extracts from the specification will give some idea of the giant spark stations proposed: "Capable of transmitting to the distant station at any time of day or night. . . . Wavelengths as great as possible within the limits of 17,000 and 50,000ft. . . . Aerials over 3,000ft to 8,000ft long, supported by tubular masts 300ft high. . . . Prime mover to be a steam turbine of between 1,300 and 2,500 h.p."

A name that has constantly recurred in our pages since the beginning—and happily still recurs—is that of H. J. Round, one of Marconi's engineers. In an article on the strength of atmospherics in relation to signals, Round described the use of a Fleming diode as a valve voltmeter to measure voltages set up by the X's—certainly our first mention of what we would now call electronics. Round has played a prominent part in many important developments.

High-speed automatic telegraphy was discussed. The transmitter was keyed by a Wheatstone machine and, for reception, there was the choice of photographic or phonographic methods. The phonograph, which allowed better discrimination between signals and X's, seems to have won the day; before long, speeds of 100 words per minute were demonstrated.

Heaviside's theory of wave propagation, enunciated some ten years earlier and now expanded and championed by Eccles, became the subject of quite violent controversy. It is pleasing to record that we came down editorially on the right side—but very cautiously: "at the moment there is a disposition to accept the hypothesis

put forward by Dr. W. H. Eccles as yielding the best explanation of the observed phenomena."

Direction finding, a brand-new application of wireless, now appeared. Thanks to the large size of the pair of fixed loops used in the original d.f. gear, sufficient signal pick-up was obtained to give fairly useful ranges without amplifying valves.

Throughout the early period wireless was bedevilled by patent litigation. During this year some sort of agreement seems to have been reached between Marconi's and their rivals Telefunken; actions and counter-actions with Siemens, who exploited the German system in Britain, were called off.

1913

EVER since the Imperial wireless scheme had been announced the Government had been constantly under criticism, mainly on the grounds that the contract had not been thrown open to tender. A technical committee was now appointed "to report on the merits of the existing systems of long-distance wireless telegraphy." The distinguished members, all Fellows of the Royal Society, included the Director of the N.P.L. and the President of the I.E.E. They obviously did a conscientious job and produced a report providing a valuable and unbiased commentary on the state of the art in 1913. The systems examined were Marconi and Telefunken (spark), Poulsen (arc) and Goldschmidt (alternator), which used a rotary r.f. generator with contra-rotating field and armature, frequency multiplication being obtained by feedback. Those responsible for these systems were invited to give practical demonstrations "if possible over distances of 2,000 miles and upwards."

According to the committee's report "Except in the case of the Marconi system we did not, however, obtain any demonstrations over a distance of even 1,000 miles". Of Telefunken, it was said that experiments were being made between Nauen and Togoland (4,000 miles) and that communication seemed possible at night. Results of the Poulsen arc system working between San Francisco and Honolulu (2,100 miles) "do not appear to have been very satisfactory". The Goldschmidt machine being set up at Hannover "was ad-

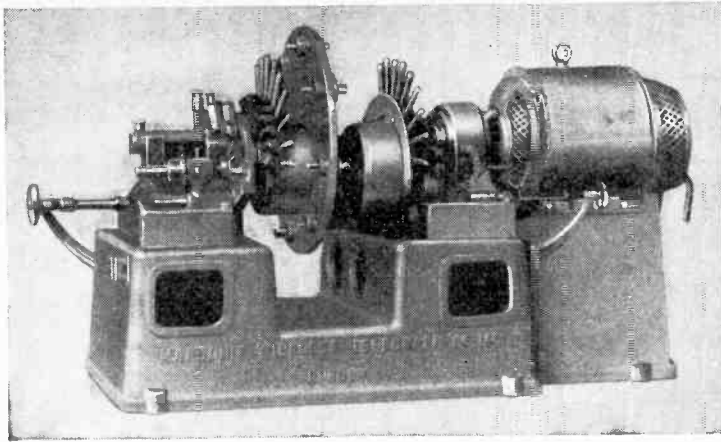

Disc discharger for the 75kW Marconi spark installation.

The huge primary winding of one of the "jiggers" (aerial coupling transformers) for the 300kW synchronous spark transmitter at Caernarvon.

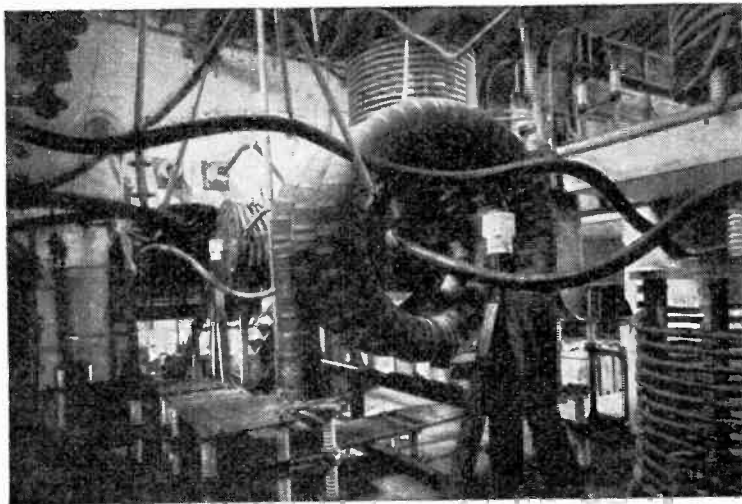

mirable both in design and workmanship" and expected to be capable of communicating across the Atlantic.

The Clifden transatlantic station was visited by the committee members, to whom high-speed and duplex working were successfully demonstrated. Of the general performance, it was said "Communication is practically continuous, though there are, no doubt, periods when the signals become very weak and even occasional periods when no signals can get through". But a note of warning was wisely sounded about the possibilities of atmospheric interference in the tropics.

In spite of this favourable report, the Imperial wireless scheme was not to have a smooth passage. Criticism of the Government continued

and a political scandal had developed. To cut a long story short, although the contract was eventually ratified by Parliament, the scheme never came to fruition. It ended with the conferring of the G.C.V.O. on Marconi and the award to his company, many years later, of £590,000 damages against the Postmaster-General for breach of contract.

Thanks to the attention focused on wireless by the *Titanic* disaster the amateur movement had begun, and we were already publishing instructional articles for the benefit of amateur readers. We showed them it was quite easy to make a start: "An old motor-cycle ignition coil will do for the transmitter and a simple crystal set for the receiver". American amateurs were now controlled, being restricted to wavelengths below 200m and input powers of not more than 1kW.

1914

THIS year was marked by the most momentous advance so far described in our pages—the practical introduction of the triode, which had got off to a false start in 1907. This

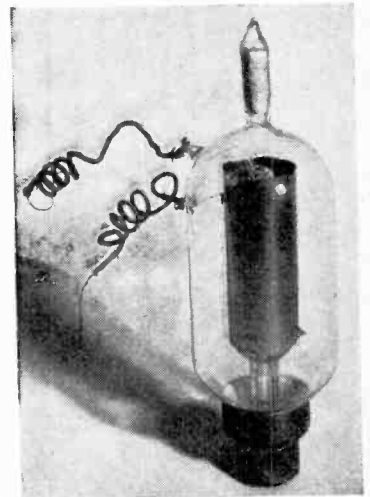

The Round-Marconi triode, one of the early practical amplifying valves.

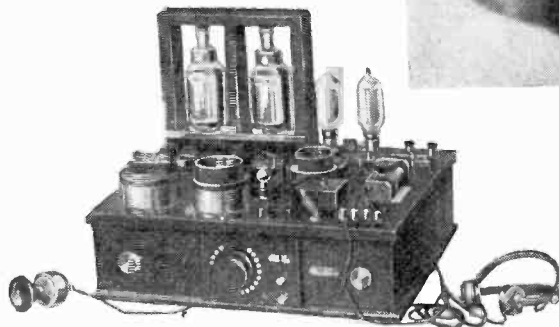

Marconi combined transmitter and receiver for wireless telephony (1914).

was used in "a practical standard set for wireless telephony" developed by Marconi. This transmitter took 10-12mA from a 500-V dry battery and was stated to have a range up to 45 miles. Hardly any details were given.

The Marconi transatlantic station at Caernarvon was opened, working on the "timed spark" system in which more-or-less continuous waves were produced by overlapping spark discharges in appropriate phase. The "tone wheel", a mechanical beat-frequency generator for c.w. reception was introduced in Germany.

1915-18

THE FIRST WORLD WAR

DURING the war our activities were severely circumscribed by what we called "the heavy hand of censorship" and, in particular, we were prevented from writing anything about the rapidly increasing use of valves for war purposes. In fact, the only "safe" technical news was that coming from neutral America. David Sarnoff, then in Marconi's W.T. Co. of America, and later to become President of the Radio Corporation of America, was for a time our New York correspondent.

Without any doubt, the most important news coming from the U.S.A. concerned the development of the triode: in particular "the simultaneous use of a single bulb as rectifier, amplifier and oscillator has already produced startling results". That may raise a smile nowadays but, at the time, it was difficult to believe that anything more sensitive and selective than a good single-valve regenerative receiver would ever be devised. The importance of heterodyne reception was fully realized, thus giving continuous wave systems a new lease of life.

Towards the end of the war there was some relaxation by the censor and theoretical articles on valves were printed. Among the authors of these were two distinguished founder-members of Phase II of wireless technology: Dr. R. L. Smith-Rose and E. V. (later Sir Edward) Appleton. Smith-Rose wrote a long series of articles, starting with elementary thermionics, while Appleton's contribution gave our first mathematical treatment of valve characteristics. Valve manufacture was advancing rapidly and as early as 1916 transatlantic wireless telephone tests were made, using 300



Police wireless car in New York (1918).



Dame Nellie Melba giving her famous broadcast concert from Chelmsford long-wave station on June 15th, 1920.

receiving-type valves in parallel in the transmitter.

In the early days most wireless stations were designed empirically but by 1917 it was thought possible to design a complete station of specified performance by applying accepted formulæ; to "fly 'em straight off the drawing board", as they say in aviation circles. A

theoretical exercise of this kind was now offered to readers in a series of articles.

The end of the spark transmitter era was now drawing nearer, thanks to improvements in continuous-wave gear and still more to heterodyne valve reception. The last of the great spark stations were those built for spanning the Pacific in two hops; from San Francisco to Honolulu (2,100 miles) and from Honolulu to Funabashi, Japan (3,350 miles).

British amateur activities had been entirely suspended since the outbreak of war but in the U.S.A. the movement steadily gained strength until America's entry into the war in 1917; by that time the supply of amateur equipment had become big business.

Television; a contributor's prophesy that went wrong: "The idea of wireless television is . . . absurdly improbable. . . . To construct wireless apparatus capable of receiving 40,000 signals in one-tenth of a second and arranging them in their correct order [would be beyond] the limit of human ingenuity."

1919

WITH the end of the war, articles of the "it-can-now-be-revealed" type were printed. One of the developments disclosed was the multi-stage r.f. amplifier with semi-a-periodic couplings.

Valves were now being produced by improved processes and the "soft" kind was fast disappearing. The generation of oscillations (by van der Pol) on a wavelength as short as 3.65m was considered a notable advance. Eccles suggested the modern valve nomenclature; diode, triode, tetrode and pentode. We were not quite at our best in editorially stigmatizing these now-universal terms as "too academic and refined to become familiar." High-power transmitting valves were now being made, allowing Marconi to span the Atlantic by telephony in daylight.

Amateur transmitting licences were not restored by the Post Office until a year after the war had ended; this delay caused much complaint.

1920

THIS was the heyday of the great long-wave stations with arcs or r.f. machine generators, operating on

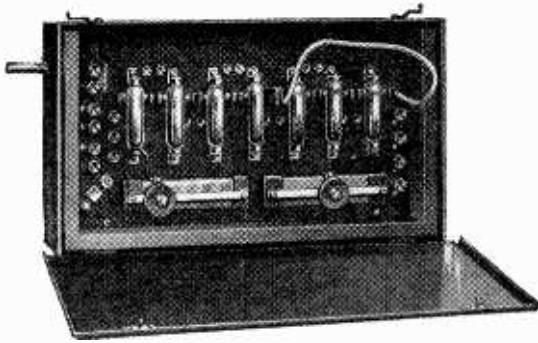

A famous r.f. amplifier-detector—the Marconi 55A with V24 type valves.



A group of passengers about to embark for Paris on the first commercial machine (Handley Page) to be equipped with radiotelephony (1920).

wavelengths most conveniently measured in miles; the longest (Bordeaux) was 14 miles. Powers were up to 1,000kW or even more. In spite of improvements, the arcs radiated a rich assortment of harmonics and "arc hash."

Continuous-wave sets for ships, wireless gear (including telephony) for the new airlines and commercially available direction finders were new developments.

The Wireless Society of London, suspended during the war, had now resumed full activity. Though by constitution an amateur body, this unique institution did in fact represent a happy mingling of amateurism and professionalism. Many of the most "eminent wireless telegraphists," as we used to call them in our earliest days, lectured before the Society. The first five Presidents—Campbell Swinton, Erskine Murray, Admiral of the Fleet Sir Henry Jackson, Eccles and Sir Oliver Lodge—had all from before the turn of the century played distinguished parts in wireless development. The Society changed its name to Radio Society of Great Britain in 1922.

1921

THERE had by now been several casual mentions in our pages of what is now called "electronics"; Appleton, in a tailpiece to a book review, referred to the valve as "an invaluable laboratory instrument" to the general physicist. The use of amplifying valves in conjunction with photoelectric cells for measuring light intensities had also been mentioned. Now came our first full-dress electronics article in a report of a paper read before the Wireless Society of London by Prof. R. Whiddington on the measurement of physical quantities. He described the measurement of short distances by capacitance variation using the beat-note method with two oscillating valves. Sensitivity claimed was 50 to 100 times greater than that of the optical interferometer.

Broadcasting in America was already under way and regular "Dutch concerts" from The Hague were started. The Marconi Company's transmissions from Writtle were licensed by the Post Office early next year. With increased interest in telephony loudspeakers became important. Most of them consisted essentially of a telephone earpiece with a horn, but the American Mag-

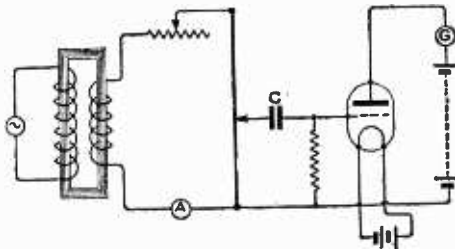

Circuit diagram of the Moullin valve voltmeter (1922) showing method of calibration.

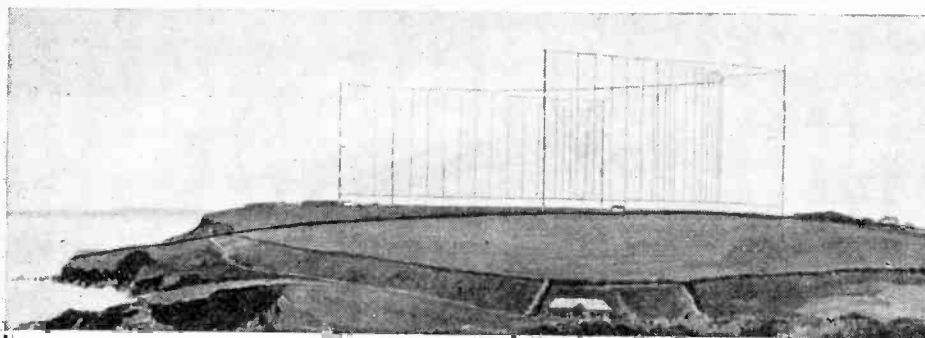

Above: The parabolic aerial reflector at Poldhu used in early short-wave beam experiments.

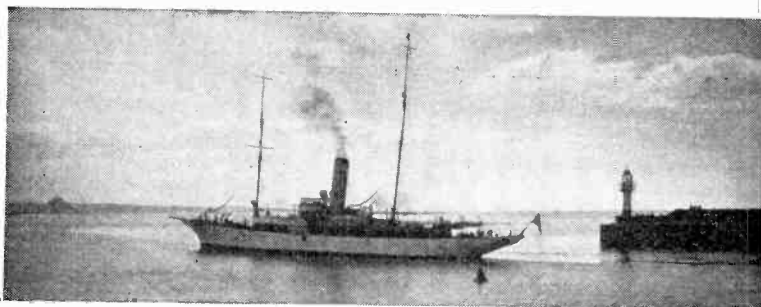

Right: A floating laboratory—Marconi's yacht Elettra.

navox moving coil and the Western Electric balanced-armature types had appeared.

1922

AMATEUR transatlantic tests were successfully carried out on 200 metres, *Wireless World* organizing the arrangements on this side. Moullin described his valve voltmeter, the first widely used electronic device. Dull-emitter valves

with a filament wattage about 1/15th that of earlier types were introduced and news of Armstrong's super-regenerative receiver came from America.

C. S. Franklin of Marconi's described an important development—the use of highly directional aerial arrays on wavelengths below 20m. But so far there was no suggestion that such waves were usable over very great distances.

Towards the end of the year the British Broadcasting Company, fore-

runner of the Corporation, began official transmissions. *Wireless World* started weekly publication.

1923

WITH broadcasting in full swing, the biggest do-it-yourself boom of all time got under way; a high proportion of receivers were home-assembled. The typical valve set of the period had a regenerative de-

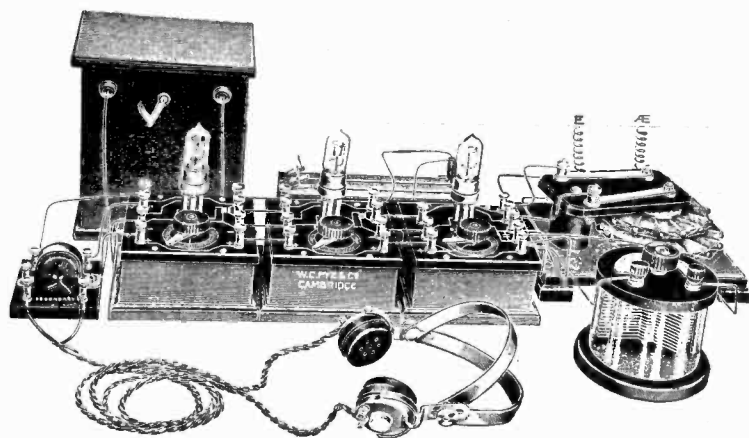

"Messrs. W. G. Pye & Co. (Makers of Physical and Electrical Apparatus) beg to announce that they have opened a Wireless Dept. at their works" (Advertisement from *W.W.* May 27th, 1922).

The unit receiver was popular in the early broadcasting era.

ductor with two transformer-coupled a.f. stages and sometimes a rather ineffective r.f. stage, stabilized by aerial loading or positive grid bias. Neutralizing of anode-grid capacitance was already known, but its use did not become widespread for several years. Cost of valve receivers was high, so many listeners used crystal sets with headphones.

The superheterodyne principle of reception was first described; this was one of the great basic inventions which got off to a slow start.

"Electromagnetic Screening," the subject of an article by R. A. (later Sir Robert) Watson Watt, seems a far cry from the author's future work in radar. More in character was his R.S.G.B. lecture "Observations on Atmospherics" (using recording gear and direction-finding) reported later in the year. "The greatest unsolved problem in radiotelegraphy is interference by X's."

1924

THIS was the year of the "wave-length revolution," a distinct landmark of the half-century. Marconi exploded his "beam wireless bombshell" by disclosing how, in the spring of 1923, he had conducted short-wave receiving tests on 93m while cruising in his yacht *Elettra* in the S. Atlantic. The transmitting station was at Poldhu, where Franklin had erected a parabolic reflector array. The British Government hastily revised their scheme of expensive mile-wavelength stations for Imperial communications and the Marconi Company undertook a contract to erect beam transmitters on a strict "no play, no pay" basis. That was probably one of the boldest commercial enterprises ever undertaken; nothing was known about short-wave propagation theory and the phased multiple "grid" aerials which were to replace the parabolic reflector system existed only on the drawing board. But fortune had favoured the brave; we now know 1923 was a sunspot minimum year; the frequencies chosen for the early experiments, though on the low side, were not so low as to be unworkable; on the other hand, they were not so nearly correct for prevailing conditions as to give an over-optimistic impression of the potentialities of short waves.

Short-wave working had by now become widespread, particularly among amateurs, and s.w. broadcasting had started in America. Other

highlights of the year: Campbell Swinton's detailed pronouncement on the possibilities of cathode-ray television and Baird's first article on his mechanical system.

1925

SOMETHING approaching the modern theory of short-wave propagation was now put forward by Appleton; Round wrote our first article on second-channel interference and other troubles to which the superheterodyne, now becoming of practical significance, is prone. Baird wrote on television by reflected light (as opposed to shadowgraphs) and that versatile genius, A. D. Blumlein, in collaboration with N. V. Kipping, discussed valve

theory. Electrical recording and reproduction of gramophone records was introduced and the quartz oscillator and piezoelectric effect were described.

The amateurs' position had, we considered, been steadily undermined by the Post Office and, feeling diplomatic methods would no longer suffice, we publicly offered £500 towards the cost of fighting a test case against the Postmaster-General. It so happened the Marconi Company (then our publisher) was at the time engaged in delicate negotiations with the Post Office: an embarrassing situation seemed likely to arise, so the obvious course was to get rid of *Wireless World* as quickly as possible. Thus the transfer to our present publishers came about. That, needless to say, is a story which did not appear in *Wireless World*.

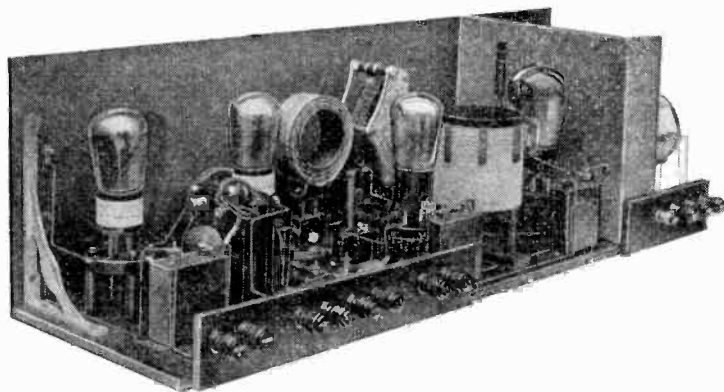

Wireless World "Everyman 4" receiver (1926) set a new standard in range and selectivity for broadcast receivers.

Details of the low-loss tuning coils used in the "Everyman 4."

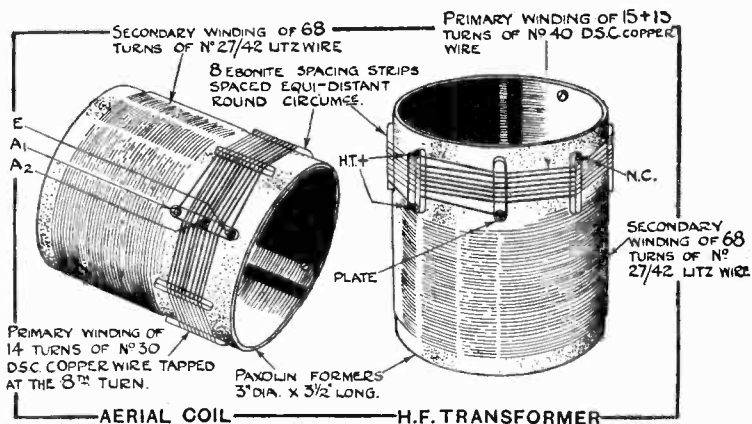

1926

SO far as we were concerned, the event of the year was the introduction of the "Everyman Four," a receiver design of outstanding performance produced by us for home constructors. The feature of the set, which survived for many years in various modifications, was a high-gain neutralized r.f. stage with coils of exceptional "goodness," based on the classical work of Butterworth and on tests of coils submitted by readers.

The first mains-operated broadcast set (Gambrell) made its appearance. The series-connected 60-mA valve filaments were heated with rectified current from the h.t. supply source. Battery eliminators were now commonplace.

1927

AT last, Heaviside's theory of a conductive layer in the upper atmosphere was experimentally verified. Amplifying work done in the previous year, Appleton wrote an article showing how, by a method of distinguishing between waves travelling horizontally and those arriving in a downward direction, he had concluded the height of the layer of ionized air at night was 80-100km.

The first public transatlantic telephone service was opened and we conducted a campaign for Empire broadcasting on short waves.

1928

A MORE scientific approach to many problems, particularly to the details of receiver design, now becomes evident. It had already been shown (by M. G. Scroggie) that even a very low value of impedance common to several anode circuits could completely spoil the performance of an a.f. amplifier. This trouble was overcome by "decoupling" individual circuits, a method originated by Ferranti. The isolation of circuits by "scientific wiring" was also described.

By now, the neutralized triode was being replaced by the screened tetrode for r.f. amplification. Output pentodes, fed directly from the detector, helped to simplify and cheapen broadcast receivers: the three-valve set was becoming the most popular.

Detection of signal echoes "from the depth of space," with a time delay of 15 sec, gave a foretaste of extra-terrestrial communication.

1929

BAIRD'S 30-line mechanical television system, with flying spot scanning, was now sufficiently developed for the B.B.C. to give experimental transmissions of it for half-an-hour a day; these were continued until 1935. The broadcasting of "still" pictures by the Fultograph system by the B.B.C. and many European countries enjoyed a short-lived vogue.

Spark transmission for ships and coast stations was slowly giving way to i.c.w. (interrupted continuous wave); for long-distance point-to-point communication short waves had almost entirely replaced long-waves except on the N. Atlantic circuit.

Broadcast receivers were now built more or less in the modern manner, with metal chassis and, quite often, built-in speakers. Mains sets with the recently introduced indirectly-heated valves were commonplace. But there were still few sets with ganged tuning. Efforts were being made to provide greater selectivity in preparation for the "Regional" broadcasting plan, which was to offer listeners a choice of two programmes. The architect of the scheme, of which many traces remain in the present B.B.C. distribution system, was P. P. Eckersley, then chief engineer, who for many years has projected his ebullient personality and original thoughts through occasional *Wireless World* articles.

1930

A LIVELY controversy arose over the so-called "Stenode" receiving system, in which sidebands lost by extremely sharp tuning were restored by tone correction. The crucial question: "was interference put back equally with the sidebands?" A related controversy concerned the physical reality of sidebands; there were several notable "heretics."

The susceptibility to cross-modulation of screen-grid valves brought about a wave of interest in bandpass filters; as a corollary, ganged single knob tuning was widely adopted for broadcast and other receivers. Per-

manent-magnet moving coil loudspeakers were now in general use.

Our funny man "Free Grid," shrugging off an Editorial footnote threatening imminent "earthing" soon after starting his whimsical writings in September, 1930, has carried on ever since with his task of preventing us all from taking ourselves too seriously. One of his outstanding contributions (in our issue of March 10th, 1933) contained a remarkable anticipation by 16 years of Orwell's "1984." "Free Grid" went one better than Orwell in giving his Big Brother an electronic "thoughtcrime" detector.

1931

PAVING the way for a better understanding of short-wave propagation, Appleton showed for the first time in our pages that there was more than one reflecting layer in the upper atmosphere. He had earlier sought the help of our readers in reporting distortion of the Baird 30-line television picture brought about by multipath propagation and reproduced a reader's sketch of a picture which clearly showed the effect.

Short-wave telegraph and telephone services had by now linked many, if not most, of the more advanced countries of the world and lack of secrecy, a handicap of wireless since the earliest days, was overcome by "scrambling."

The N.P.L. was taking steps to develop a standardized form of test for the sensitivity, selectivity and fidelity of receivers. The decibel scale began to come into general use in place of such expressions as "times amplification," etc.

So far as receivers were concerned, the introduction of the variable- μ valve with linear characteristics largely overcoming the difficulties of cross-modulation, was an important development. "Straight *versus* superhet" became a burning issue, but the outcome was not in much doubt. Realizing that ganged tuning with "potted" coils would soon become universal, we commissioned a special investigation of the characteristics of coils. Moving-coil speakers, now generally built into the receiver, were almost universal: during this and the preceding year the finer points of their design were discussed in a long series of important articles by Dr. N. W. McLachlan.

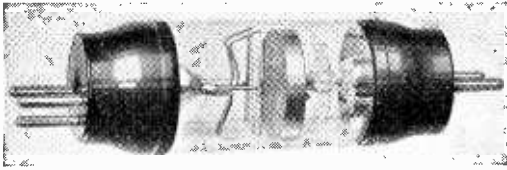

▲ The introduction of the screened-grid valve in 1927 enabled higher r.f. gains to be achieved with stability.



▲ A. A. Campbell Swinton, F.R.S., the prophet of television as we know it today, who died in 1930.

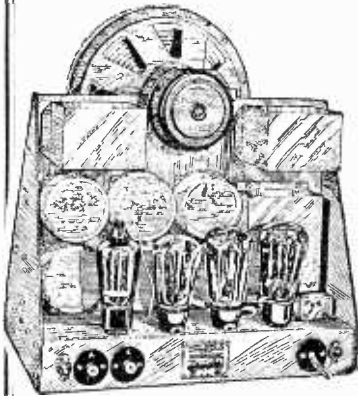

▲ A highly-developed broadcast receiver of the late "straight-set" period: the Murphy A3 (1931).

Sketch by a reader (W. B. Weber) showing observed effect of multi-path propagation on a 30-line television picture (1931).

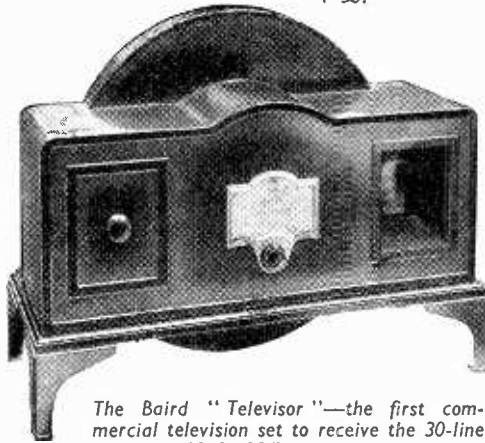
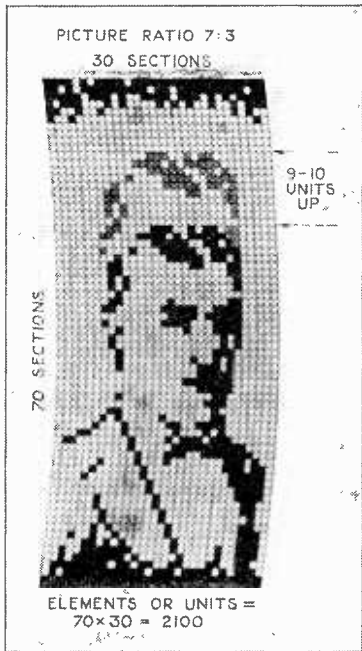

▲ The Baird "Televisor"—the first commercial television set to receive the 30-line pictures (1929-1935) transmitted through the B.B.C.



▶ A turn of this kind, giving wide contrasts of light and shade, was thought to provide "genuine entertainment value" on 30-line television.

1932

THOUGH many ships still had spark transmitters, marine wireless had by now made considerable progress. Short-wave equipment for telegraphy was commonplace and some 15 transatlantic liners provided a radio-

telephone service for passengers. The G.P.O.'s long-distance station for working to ships had been much improved and now had a rotating beam array with an electrically-interconnected receiving beam turning in unison at the remote controlling station.

The cathode-ray tube had by now

become a regular article of commerce and its applications were no longer restricted to research work; it was being used for routine factory testing.

A stir was caused by the introduction (from Germany) of coils with powder-iron cores; inductors of this type were soon to be widely used in receivers in place of bulky air-cored windings.

A B.B.C. service of official "Empire" broadcasting, for which we had campaigned for some six years, was at last started. Wire and wireless were linked by a five-metre Post Office telephone link across the Bristol channel.

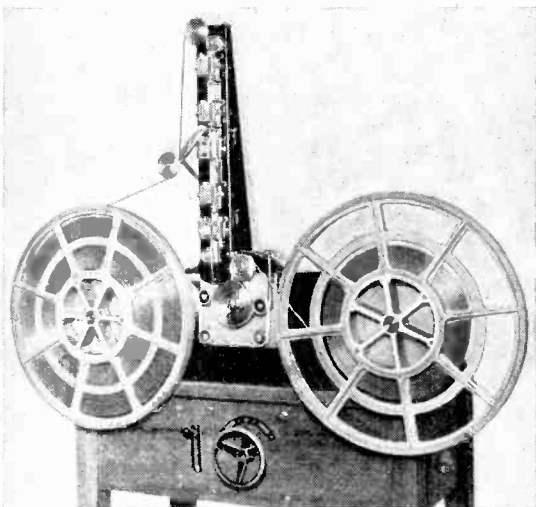

Marconi-Stille steel tape recorder.

1933

WITH the increase in sensitivity of receivers and the growing electrification of the country, man-made interference had become a serious problem. Following suggestions made in *Wireless World* the I.E.E. had set up a committee to consider the possibility of legislation and interference complaint questionnaire forms could be had from post offices. This service is still available to the public.

The "small superheterodyne" was soon to become Britain's standard broadcast receiver: early versions had bandpass input, single-valve frequency-changer, one i.f. stage and a second detector feeding a pentode output valve. R.F. pentodes were by now widely used and the electron-coupled frequency-changer had appeared. Refinements like automatic gain control, noise-suppression switches and, occasionally, "quiet" a.g.c., were coming in. For battery sets, economy circuits with push-pull output valves biased to cut-off were being used. Built-in car sets had arrived, so we described methods of suppressing ignition interference.

S.T.C. put up for the Air Ministry a decimetre-wave (17.5 cm) link working across the English Channel.

An historic high-quality loudspeaker: the Voigt domestic corner horn in its original form (1934).

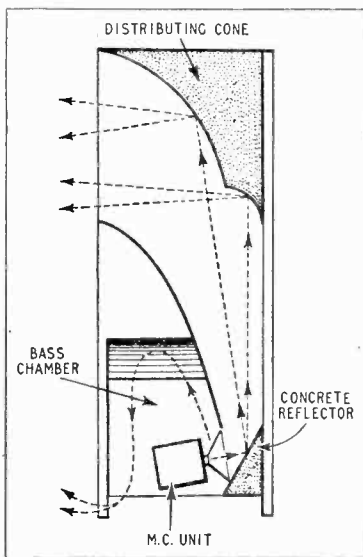
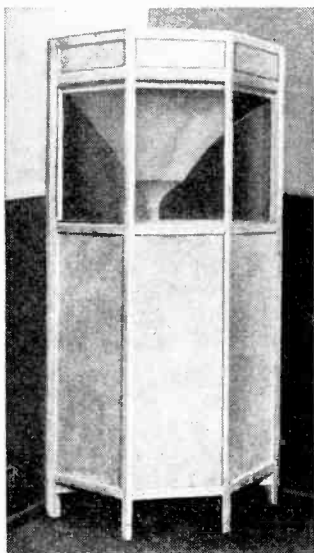

1934

SEVERAL high-definition television systems were now being described and Zworykin's "Iconoscope" camera tube was announced. Apparently the audience of the Baird 30-line broadcasts was greater than we had thought; publication of a proposal to suspend the transmissions brought,

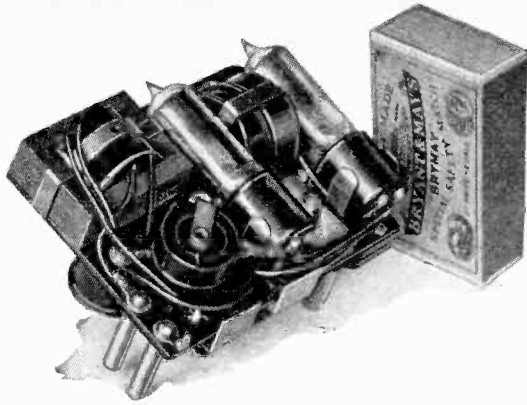

Forerunner of the (transistor) pocket portable: chassis of a super - regenerative valve set (1935).

technology he has been a doughty fighter against the many irrational and confusing technical terms which make life so difficult for the student and beginner. And "Cathode Ray" has won many of his battles: few of us now dare to speak of "non-linear distortion" unless we really mean it is the distortion which is non-linear!

Other innovations of the year: investigations of the effect of sunspots on h.f. propagation: the Marconi-Stille magnetic wire recorder: high-note speakers (tweeters): the *Wireless World* Quality Amplifier, with resistance-coupled push-pull, which set a standard for high-quality reproduction for many years: the Voigt domestic corner horn loudspeaker.



within the week, protests from a large number of readers. No doubt the transmissions on this system, crude as it was, did a great deal to stimulate work on television; some correspondents were now using cathode-ray receivers.

The introduction of suitable valves

now made practicable the "universal" a.c./d.c. receiver, without a transformer.

Our contributor "Cathode Ray" started his inimitable series of expository articles in 1934. Apart from his services as a talented and sympathetic expositor of the trickier aspects of

1935

THE scene was now set for the start of a regular British television service

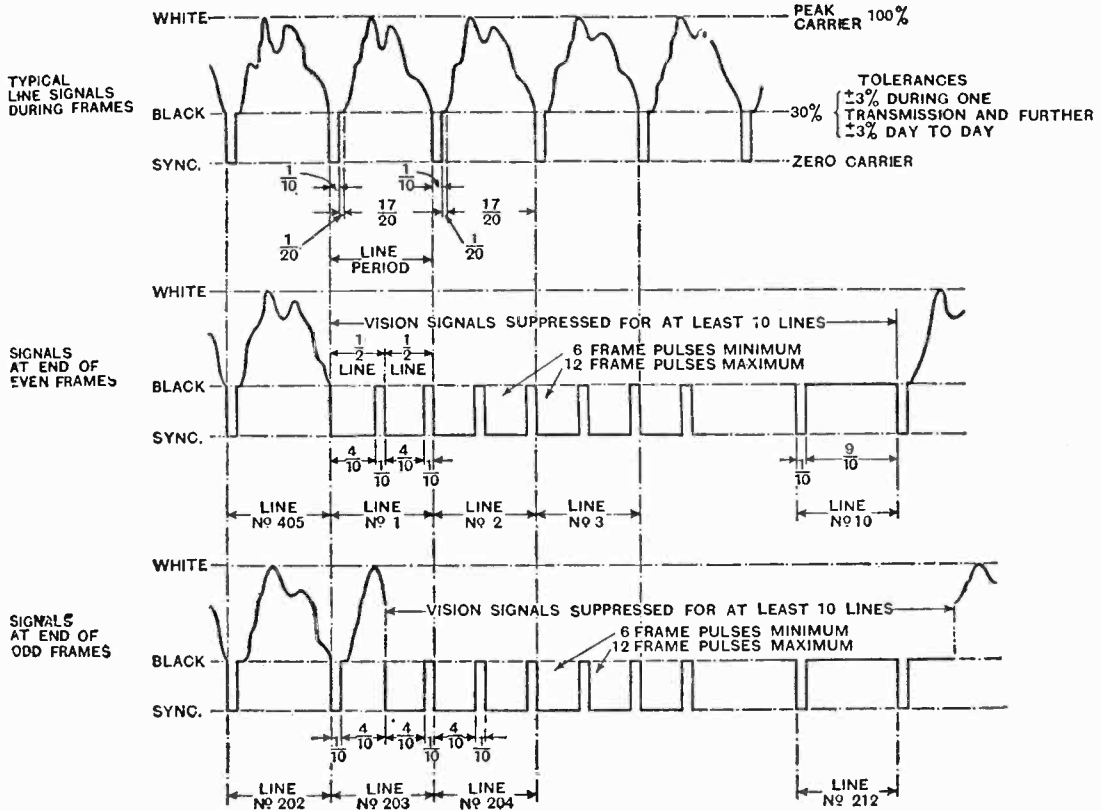

Characteristics of the Marconi-E.M.I. television system as first issued in 1935.

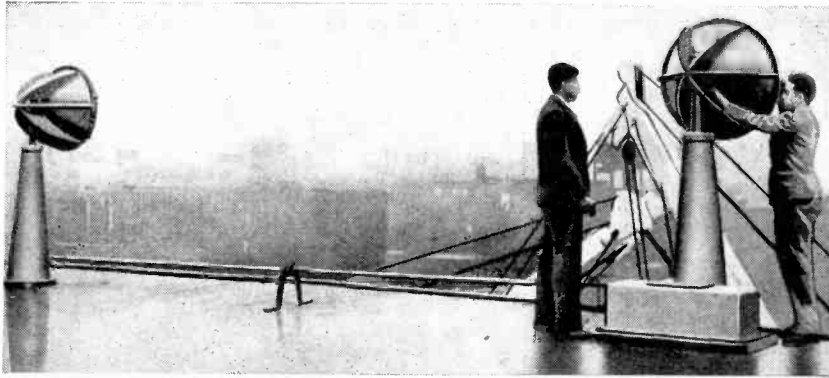

Radar: S.F.R. "obstacle detector" fitted in the liner Normandie (1936).

next year and it was decided that alternative test transmissions should be made on the Marconi-E.M.I. system (405 lines interlaced; characteristics basically as at present) and a new Baird system (240 lines with sequential scanning; 25 frames per second). One of the television systems much discussed was the "intermediate film," with a time delay of about half a minute; it was easier to scan the film image than the direct scene.

Our "Diallist" now started his non-stop radiations of his random and highly individualistic commentary on the happenings of the times.

Some developments of the year: Armstrong's frequency modulation in America; the electron multiplier; "all-wave" tuning and refinements like contrast expansion and automatic selectivity control in broadcast receivers; public address became important.

1936

THIS year marks the end of our first quarter-century and it is time for a backward glance. And a very appropriate time, as it happens: technical development was moving rapidly into Phase III, the era of high-definition television, industrial electronics, microwaves, radar and pulse techniques. Phase I had been the evolution of spark telegraphy on medium and long waves. Phase II, coming to an end in 1936, had begun with the practical development of the amplifying and oscillating valve in 1911-1913, followed by radio-telephony, broadcasting, the full exploitation of the multi-mile wavelengths and then of those rich bonanzas the h.f. and v.h.f. frequency bands; also

the start of electronics for scientific purposes. Most of this progress had been made possible by valve improvements; our contributor, "Cathode Ray," produced detailed support for the assertion that 92 valves of the 1921 type would be needed to provide the performance of the typical five-valve broadcast receiver of 1936. And a resourceful designer, well primed with the accumulated knowledge of 1936, would have been needed to achieve that performance.

A quick glance through our 1936 volume shows how fast radio technology was then moving into modern times: The B.B.C.'s London television station started the world's first regular high-definition service; the French S.F.R. company introduced the "obstacle detector," a non-pulse radar device; "plumbing" was coming in and waveguide theory was treated; there was a number of articles on electronics; an editorial plea was made for the abolition of spark transmission.

A quarter-century's progress in wireless telegraphy; the *Queen Mary* on her maiden voyage handled as many words of traffic in the few days of the crossing as the great transatlantic station Clifden had averaged in two months in 1910/1911.

1937

NOW that regular transmissions had started, television became the centre of interest and was much discussed both in theory and practice. The first 405-line commercial receiver to be reviewed was an H.M.V. model giving a picture 10in by 8in viewed indirectly in an inclined mirror. The vision unit had a "straight" six-

stage r.f. amplifier, the sound receiver being a superheterodyne. Deflection was magnetic and the set, complete with aerial, cost 95gns. After a few weeks' trial the Baird 240-line transmissions were discontinued, leaving the 405-line system, basically as it is today, as the British standard. One of the first television outside broadcasts was that of the coronation procession of King George VI.

Designs for the home construction of ordinary broadcast receivers were now seldom offered in our pages; the readership was undergoing a change, as was shown by a questionnaire. About half our readers were now professionally concerned with radio.

The "all-wave" broadcast receiver, often with three short-wave bands, was now firmly established and the complicated switching required had made the wafer switch almost universal.



Guglielmo Marconi who died in July 1937, aged 63.

1938

THE days were long past when the vagaries of short-wave propagation had been stoically accepted as something to be endured, like the weather. Diversity reception was now well established; a description of the B.B.C.'s highly developed receiving station at Tatsfield was published. And the minor deficiencies of equipment generally were less readily tolerated. Now came a determined effort to overcome tuning drift by more basic and cheaper means than automatic frequency control; much attention was given to temperature-compensated components.

The public demand for television receivers had so far been disappointing. Now, in an attempt to attract buyers, cheap sets with small 5-in, 6-in or 7-in tubes were introduced. One example, costing 29gns, had a 5-in tube giving a picture 4½ in by 4 in.

Push-button tuning became the vogue in sound broadcast receivers. There were three main methods: mechanical location of the condenser; motor drive of the condenser; separate pre-tuned circuits for each station.

In brief: electronic techniques used for neurological research and Grey Walter's electro-encephalograph produced; improved electron microscope announced; "wobbulator" and Cossor double-beam oscilloscope introduced.

1939

EVER-INCREASING interest in sound reproduction was further stimulated by B.B.C. experimental transmissions of high quality on 45Mc/s; this was Britain's first taste of v.h.f. broadcasting, though f.m. had already started in America.

The Western Electric "radio altimeter" for aircraft, an f.m. device working on frequency differences between the emitted wave and reflections received from the ground, was described.

In television, the public had not taken kindly to the small "peephole" sets introduced last year and there was a reversion to larger tubes, the 12-in size being most favoured. Ignition interference was being discussed and voluntary suppression was suggested.

Some new introductions: the cathode follower; "all-glass" valves with short, well-spaced internal leads;



Cossor Model 54 with 6-in tube (1938).

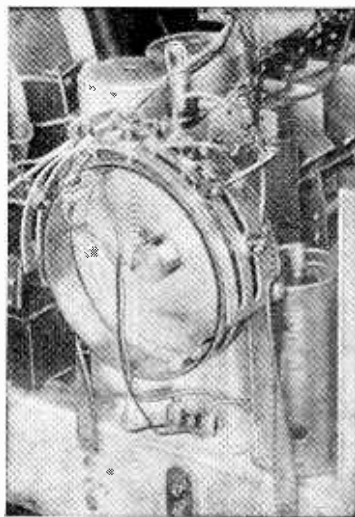

Drum-type commutator of the H.M.V. motor-driven tuning mechanism (1938).



One of the popular "semi-communications" receivers of the early days of the war: the Pye "International" with band-spreading on six short-wave ranges.

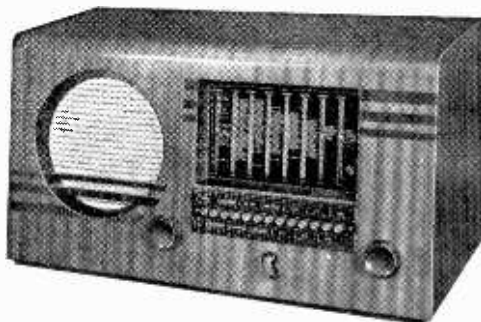

forced air cooling for high-power transmitting valves; short-wave therapy.

With the threat of imminent war, *Wireless World* had, with official approval and collaboration, instituted early in the year a "National Wireless Register" through which readers were able, without any liability, to have a record of their technical qualifications made available to the appropriate authorities. The Register was later to prove a valuable source of technical man-power for war-time radar as well as for communications.

1940-44 THE SECOND WORLD WAR

AMONG the immediate results of the outbreak of war in September 1939 was the closing down of the television service and of amateur transmission; car radio was banned later. B.B.C. headquarters "moved into the country" and a single-programme service was transmitted from synchronized stations to avoid giving direction-finding help to the enemy. There was a short-lived boom in receivers, especially in the recently-introduced "semi-communications" models, which offered an exceptionally good performance on short waves. This was mainly wanted for the reception of news bulletins from overseas, and especially from neutral sources. Information on short-wave receiving conditions was also wanted; for some time we published ionosphere forecasts provided by Cable and Wireless, but these were eventually stopped by the censor. However, no objection was raised against "do-it-yourself" forecasting and general articles on propagation by T. W. Bennington were continued.

So far as *Wireless World* was concerned, the war brought an abrupt change from weekly to monthly publication and, with a depleted staff, we did our best to meet the changing needs of readers, especially in producing instructional articles on new subjects: morse telegraphy was

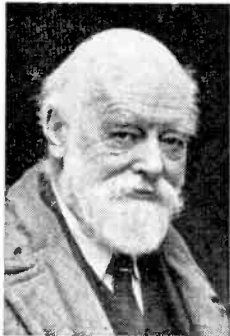

Sir Oliver Lodge, the pioneer of "syntony" (tuning), died in August 1940, aged 89.

connected with it, especially pulse techniques, were completely banned. The authorities had taken us into their confidence about radar before the outbreak of war, so we knew what to avoid. There was a transient lifting of the veil of radar secrecy in 1941, mainly as an aid to the recruitment of civilian technicians, especially from America, but we were allowed to print only a few dozen words of basic description. One of the few electronics developments which could be treated at length was radio-frequency heating.

The fusion of the Institute of Wireless Technology with the British Institute of Radio Engineers and the deaths of Sir Oliver Lodge, of the German pioneer von Arco, and of Nipkow, the originator of television scanning were reported.



John Logie Baird, the pioneer of practical television, who died in 1946, aged 57.

1945

WITH the end of the war in sight, we were able to publish the first full article on the fundamental principles of radar. Appropriately enough, the

author was Smith-Rose, who, towards the end of World War I, had given our first detailed exposition of the amplifying valve. Pulse modulation, an offshoot of radar, was described later, as was the proximity fuse, "a radio station in a shell

now important. And a rather unexpected demand arose for the treatment of topics bearing no relation to the grim realities of the times—for maintaining the journal, as a correspondent put it, as "one of the few remaining links with normality." Escapism also manifested itself in lively discussions by contributors and correspondents of the changes in radio and electronics they hoped to see in the brave new post-war world. The phrase "after the war" recurred constantly.

Maintenance of interest in high-quality sound reproduction was probably another manifestation of escapism. In this sphere an important war-time article was "The Acoustics of Small Rooms," by J. Moir. The kind of acoustics discussed by Moir had hitherto been studied mainly in relation to halls and large rooms.

In spite of restrictions, readers were kept fairly well-informed on the underlying reasons why valves were working better and better on ever-higher frequencies by a series of articles by Dr. Martin Johnson.

Though censorship was quite different from that prevailing in World War I, it did in fact bear quite heavily on the contents of the journal, as most of the developments now emerging were being applied to purposes of war. Radar and everything

Sir Ambrose Fleming, who died in 1945, aged 95.

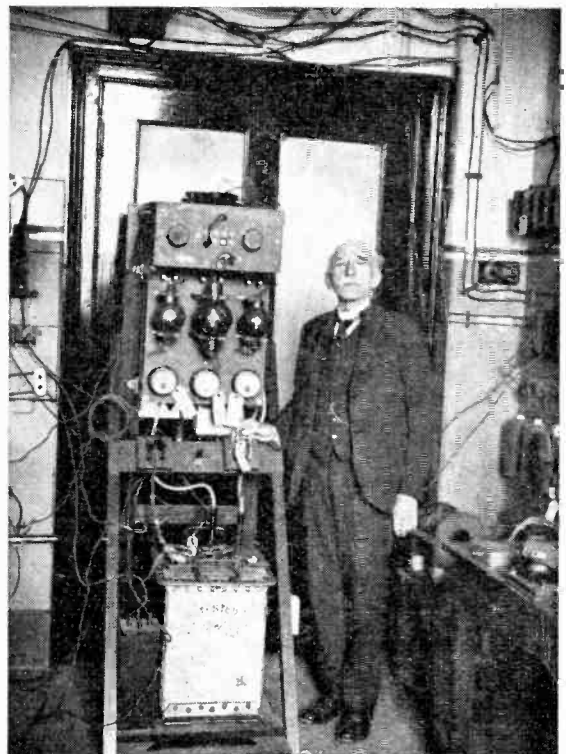

nose-cap," which made use of the Doppler effect. The fuse marked the start of the trend towards miniaturization of components, one of the features of the coming decade.

What may well turn out to be a strikingly accurate forecast of things to come was given in Arthur Clarke's article "Extra-Terrestrial Relays." Clarke contended that artificial earth satellites would provide the most effective and economical means for inter-continental telegraph and telephone communications and for distributing world-wide television. His proposals were described in considerable detail; their essential practicability has not been controverted.

1946

MUCH new information on radar was now published, but *Wireless World* considered it had come too late. Many of the devices, including some of essentially British origin, had already been described in American journals, and subsequently repeated in the technical Press of the world without emphasis on the country of origin. It was thought that British prestige

"The greatest invention of the war": cavity magnetron with a peak output of 2,500kW, photograph alongside a 6-in rule.

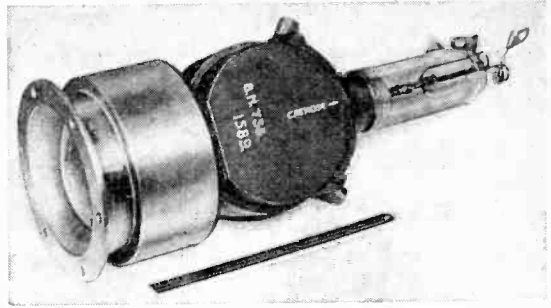

had suffered through these delays. The cavity magnetron, produced by Randall, Boot and Sayers was considered the most important single development.

Parts of the inner story of radar development were still coming out as late as 1952, when Government awards were made to the pioneers: £50,000 to Watson-Watt "for the initiation of radar" and other awards ranging from £12,000 to £250 to twenty others.

The Physical Society's first post-war exhibition in 1946 showed in an impressive manner how deeply radio techniques had infiltrated into most

branches of applied physics during the war years.

In brief: London television station re-opened; the Decca navigational system described; death of Baird, aged 57; the German Magnetophon tape recorder described.

1947

THE first post-war Radio Exhibition gave a clear indication of how the industry had progressed during the past seven years. Equipment of every kind was better designed and better

The proximity fuse, "a radio station (sending and receiving) in the nose of a shell."



One of the first photographs of radar equipment to be released: an underground station for location of enemy aircraft and fighter control.

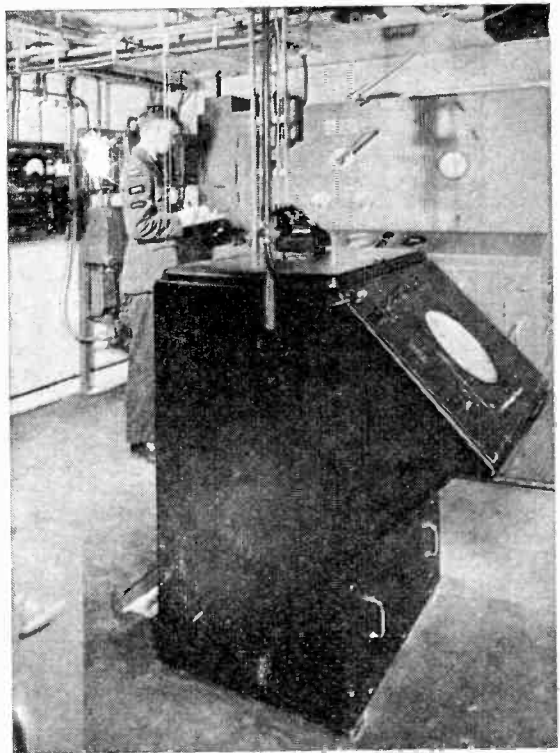

made, while the uses of radio and radio-like devices had been vastly extended, partly thanks to miniaturization and tropicalization. In communications, the greatest advance had been in pulse modulation techniques and in the attainment of a high degree of secrecy by the use of centimetric waves in narrow beams.

The Williamson amplifier design, published this year, seemed to satisfy the most exacting requirements of the "high-fidelity" enthusiasts and soon variants of it were to appear in many countries. It was the first design for home construction to exploit the use of direct coupling and meticulous design in the output transformer to reduce phase shifts and to enable a high degree of negative feedback to be used with stability.

The Marconi Company celebrated its 50th anniversary.

1948

THE transistor, probably one of the half-dozen most significant radio devices of the half-century, was announced. What was now briefly described was the original point transistor produced by Shockley, Bardeen and Brattain in the Bell Telephone Laboratories.

The International Radio Convention, the first to be held since 1938, issued its decisions. Since the previous Convention in 1938, the highest frequency allotted had risen from 200Mc/s to 10,500Mc/s.

In brief: Appleton awarded the Nobel Prize for ionosphere researches; British sub-miniature valves, 10mm diameter, 25-mA filaments introduced by Mullard; frequency-shift keying now widely used for high-speed telegraphy; mobile radio licences granted more freely by the G.P.O.



"There may possibly be a sufficiently conducting layer in the upper air. . .". Oliver Heaviside, the centenary of whose birth was celebrated in 1950.



Sir Edward Appleton, whose pioneer scientific work paved the way for radar.

1949

AROUND this time there was much discussion of television standards. In the previous year the Postmaster-General had decided the 405-line British system was to be retained "for a number of years": later, an international study was made to decide upon the standards for the continent of Europe. *Wireless World* now decided the British system was even better than had been originally thought, being economical in both bandwidth and receiver cost. Its general adoption was therefore advocated and much information was published on line standards in relation to true definition in both horizontal and vertical planes.

In brief: commercial radar began to make spectacular progress; printed circuits were coming into the limelight; a new Wireless Telegraphy Act, extending the P.M.G.'s powers and allowing him to control interference, was passed.

1950

TELEVISION was now beginning to spread over the country and, as a result, the tunable receiver appeared. It was more usual, though, to provide interchangeable tuning units for the various channels. In anticipation of v.h.f. sound broadcasting, the provincial television stations were fitted

with a superstructure carrying a slot aerial.

At the British Sound Recording Association's exhibition 33 $\frac{1}{2}$ -r.p.m. records (which had been exported for some time) made a first appearance. In addition to longer playing time they offered, thanks to the use of improved moulding material, lower surface noise, increased dynamic range and longer life.

In brief: centenary of Heaviside's birth; television boom in America (2 $\frac{1}{2}$ million sets sold in 1949).

1951

WHAT amounted virtually to a new use of radio technique was now coming into prominence. As long ago as 1932 it had been known that radio waves were reaching this planet from outer space; in 1948, localized sources of emission, since known as radio stars, had been detected. Now radio astronomy—the use of the so-called radio telescope—was made possible by improved low-noise receiving techniques. The famous station at Jodrell Bank, with its huge steerable "dish," had already begun probing into space at distances far beyond the range of optical telescopes.

In brief: Interest in electronic computers began to widen; much discussion on frequency *versus* amplitude modulation for v.h.f. broadcasting; marked growth of mobile radio telephony, including installations in London taxicabs; tape recorders the centre of interest in sound reproduction.



Sir Robert Watson-Watt who directed the initial investigations into the use of radio wave reflections for the location of aircraft.

1952

SOME of the exhibits at the Physical Society's annual exhibition showed how widely electronic techniques had now been adopted for "run-of-the-mill" industrial processes, as opposed to their original laboratory uses. In the textile industry it was being used for measuring the tension of yarn and for showing irregularities in its weight per unit length. Supersonic waves were being used as a matter of routine for the detection of flaws and for determining thicknesses with high accuracy. Perhaps the most important of all was the growing use of electronic controls in the chemical industry.

Detailed information came from the U.S. Bureau of Standards on "a new kind of v.h.f. propagation," later to be known as "ionospheric scatter." Weak but consistent signals on a frequency of 50Mc/s had been received over a period of many months at a distance of 774 miles. The power used was 23kW, the signals being radiated from a high-gain aerial set at an elevation angle of seven degrees.

1953

FOR nearly a quarter of a century there had been agitation for control by law of man-made interference with radio reception. In 1933 a committee had been set up at the suggestion of *Wireless World* to investigate the possibilities but the labours of that committee and of various successors had failed to produce an agreed basis for legislation. Now, at last, the Postmaster-General, using powers conferred on him by the Wireless Telegraphy Act of 1949, made a start by issuing regulations for the compulsory suppression of interference from newly-built internal combustion engines.

A minor difficulty in presenting information on a rapidly growing science is that the terminology, sometimes hastily and arbitrarily chosen, is often quickly out-dated by developments. One of the words about which ambiguity had long existed was "electronics." Transistors were now coming into general use and the fact was recognized by the addition of the words "and semiconductors" to the official definition.

In brief: The Coronation broadcast, the B.B.C.'s most ambitious undertaking, relayed on television to the Continent; 50th anniversary of the first international radio conference.



(Copyright: Int. Tel. Union.)

Edwin H. Armstrong, pioneer of frequency modulation and among the earliest workers in regeneration, super-regeneration and the superheterodyne.

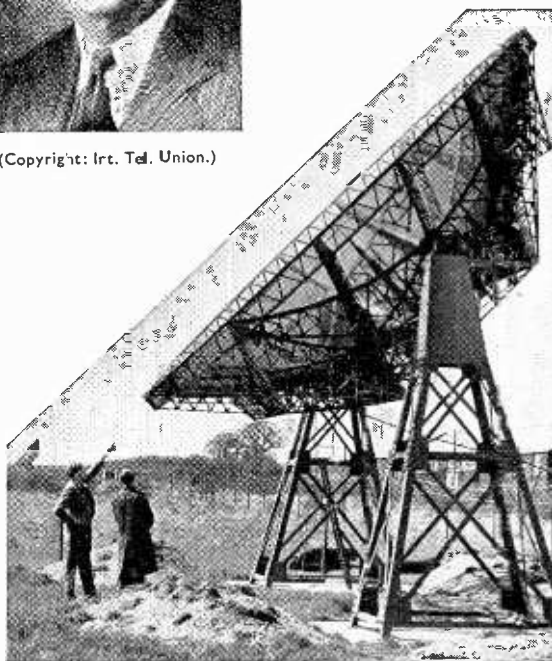

Radio-astronomy: two spaced paraboloids for producing a multi-lobed interference pattern (Cambridge University).



Interest in sound reproduction: G. A. Briggs' demonstration of comparisons between reproduced and "live" musical performances filled the Royal Festival Hall, London.

1954

WE had the sad duty of recording the death, by his own hand, of Edwin Armstrong, one of America's most distinguished radio pioneers. His most important work had been in the fields of valve regeneration, the superheterodyne receiver, super-regeneration and frequency modulation. He had been involved in much patent litigation. Only a few weeks before his death Armstrong had written a letter for our correspondence columns to keep the history

1955

NARROW-BAND ionospheric "scatter" transmission, first reported some years earlier, had now been tested up to ranges of 1,250 miles on the v.h.f. band. This year attention was turned to tropospheric u.h.f. scatter, offering ranges up to 200 miles with a much wider bandwidth. Both systems called for highly directional aerials and, between them, were thought to have a useful future for communication at ranges too long for normal v.h.f. and too short for

reliable high-frequency working. Electrostatic loudspeakers had hitherto been considered incapable of reproducing low notes. The description (by P. J. Walker) of a wide-range electrostatic speaker, working from 40c/s upwards, caused great interest.

"Automation," the witch-word of the year, enjoyed a short-lived vogue. Though there was some uncertainty as to its precise meaning it did clearly signify more work for industrial electronic control devices.

In brief: Atlantic telephone cable laid; B.B.C. started f.m. broadcast service.

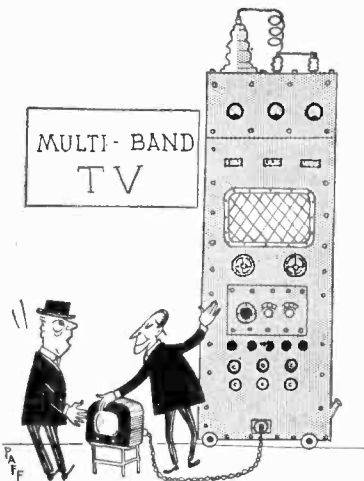

No, Sir! This is the set and that is the converter. (Misgivings were being expressed about the technical difficulties of adapting existing television receivers for reception of the projected Band III service.)

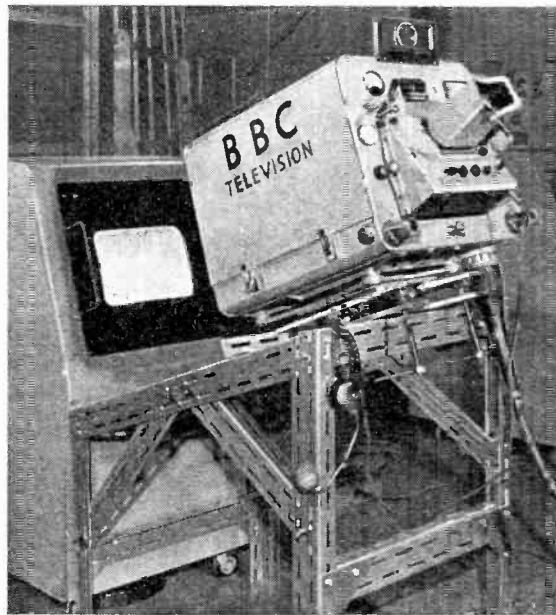

B.B.C. equipment for converting the French 819-line pictures to the British standard.

straight" on the early development of the triode. Nobody, he contended, had made a serious study of how it worked until six years after it had been introduced.

Parliament passed an Act setting up the Independent Television Authority. As a result, there was a minor revolution in the design of television receivers, which in future would have to work on Bands I and III.

In brief: Printed circuit techniques now widely used; ferrite rod aerials in portable receivers; permanent "Eurovision" television links set up on the Continent; interest in high-quality sound reproduction reached new heights.



Doppler navigation equipment (Marconi) in a Viking aircraft.

1956

BY now transistors had ousted valves in hearing aids and some all-transistor "personal portables" had appeared. But the transistor was still incapable of equalling valve performance at the higher frequencies and some of these sets had valves in the r.f. and i.f. stages, with transistors in the a.f. section.

For point-to-point radio-telegraphy the teleprinter had been steadily replacing older methods. Accuracy and speed had been progressively improved by refined and highly developed methods of "clean-

1957

THE terms psycho-acoustics and psycho-optics were by now becoming fairly familiar and it was realized increasingly that the "classical mechanistic approach" did not provide solutions to all the problems of electrical communication. As Dr. Colin Cherry pointed out in an important article, that approach often ignores the real purpose, which is to transmit information from person to person. Chains of communication should sometimes be modified to suit psychological needs.

An exciting event was the recep-

World has through the years stuck closely to its last and, except when our specialized interests are directly affected, has taken little notice of the great social, economic and political changes of the half-century. We have, though, commented on the fact that the emancipation of women has had curiously little effect in technical radio, which remains an almost exclusively male preserve. This year we reported that Kathleen A. Gough had the distinction of being the first woman in nearly sixty years to be elected to full corporate membership of the I.E.E.

In brief: 1¼ million licensed stations in U.S.A. (against under 1,000 when we started in 1911), stereophonic reproduction commercially established.



Experimental tropospheric scatter station at Start Point: frequency 858Mc/s, power 10kW.

1959

AN article on automatic error correction in multiplex teleprinter working showed in an impressive way how radio-telegraphy had been improved and refined during recent years. It was suggested that, on a poor "unprotected" circuit producing one error per hundred characters, the introduction of automatic repetition of detected errors might well reduce the error rate to one character in 10,000.

Within the short space of ten years the digital electronic computer had grown from a university or Government laboratory curiosity into a fully developed and engineered commercial product. So far most of them had been "scientific" computers, but machines for business data processing were rapidly emerging.

Two "quiet" microwave amplifiers, the maser and the parametric amplifier, were described. Both offered a solution of one of the most basic problems of radio—how to improve signal/noise ratio.

In brief: much discussion of stereophonic reproduction; B.B.C. serving 98.7% of population with television and 96.4% with v.h.f. sound.

1960

THE idea of radio communication via artificial earth satellites, which seemed little more than "a pleasant exercise in speculation" when first put forward by Arthur Clarke in our pages 15 years earlier, now began to look much nearer realization. The practical possibilities of using both

ing up" the received wave form.

We were able to take our courage in both hands and assert that the British television receiver was virtually standardized at last. "For the first time it is possible to put forward a general description of a receiver which will apply with remarkable accuracy to the great majority of modern sets." The "straight" r.f. amplifier had disappeared some years earlier and tubes were getting bigger; 17-in was now the most popular.

In brief: Decca introduced "true-motion" radar, Ampex television tape recorder announced; Shockley, Barden and Brattain awarded Nobel Prize for work on transistors.

tion at many places in Britain of signals from the 1-watt transmitter in the first of the Russian artificial satellites.

In brief: Marconi Doppler navigation system for aircraft described first British all-transistor digital computer (Metropolitan Vickers).

1958

THE introduction of an experimental all-transistor television receiver gave an indication of the notable advances in transistors, which could now work at v.h.f. and also deal with considerable power.

Generally speaking *Wireless*



A. D. Blumlein whose early and thorough investigations of stereophonic recording and reproduction were "re-discovered" in 1958.

vision] station, almost every part of which owed something to Blumlein, made straight up from drawings to begin the world's first public high-definition service in 1936, was still in use in 1950."

The death of Dr. G. W. O. Howe severed a link with our earliest days, since when he had been prominent in academic wireless circles. For 30 years he had been Technical Editor of our associated journal *Wireless Engineer* (now *Electronic Technology*).

1961

IT is easy enough to see in proper perspective the progress made during the first quarter-century covered by this survey and to say with confidence that at the end of it electronics technology was rapidly moving into Phase III, the era of high-definition television, industrial electronics, microwaves and radar. Enormous advances have been made during our second quarter-century, but have we in fact moved into a distinctly new phase of development during the period? If so, when and why? Has anything been introduced to compare with such far-reaching developments of the 1911-1936 period as the amplifying/oscillating valve, the exploitation of the h.f. and v.h.f. bands, telephony, sound broadcasting and scientific electronics?

All those questions are more appropriate to a debating society

meeting than subjects for dogmatic pronouncements. It would be ridiculous to deny, though, that most of the techniques of 1936 have been refined almost beyond recognition and that many basically new things have come in. Of these, outstanding examples are transistors and masers, both of which depend on recent extensions of man's knowledge of the nature of matter.

Looking back over the longer term, it seems impossible to find a yardstick to measure the tremendous progress of the full half-century. Nearly all the activities with which we and our readers are now concerned had not even started when we began in 1911. A Rip van Winkle from our Volume I, resuming his readership during the past few months, would find most of our present contents entirely beyond his comprehension.

But our Rip Van Winkle of 1911 would discover one thing to seize upon. In his day, range of communication was the simple yardstick and the main criterion of progress; since wireless began each successive increase of distance had been a landmark. Remembering that Clifden, the wonder-station of his time, had just managed to achieve a dependable range of 2,000 miles, he would read with amazement of "successful communication out to a distance of 23 million miles" with a space vehicle. And would he be far from the truth in thinking that increase in range gives a fair measure of the achievements of the half-century?



passive (reflecting) and active (re-transmitting) satellites were discussed in an article by R. J. Hitchcock, who drew attention to the need for early international agreement on the allocation of suitable frequencies for the purpose, preferably in the band 2,000-6,000Mc/s.

Tribute was paid in an article by M. G. Scroggie to the memory of A. D. Blumlein, one of the most talented, versatile and prolific of British electronics technologists. During his tragically short working life of 17 years Blumlein was granted 132 patents—one every 46 days! "It is significant that the E.M.I. equipment of the Alexandra Palace [tele-



The Puerto Rico ground station for working to the "Courier" satellite.

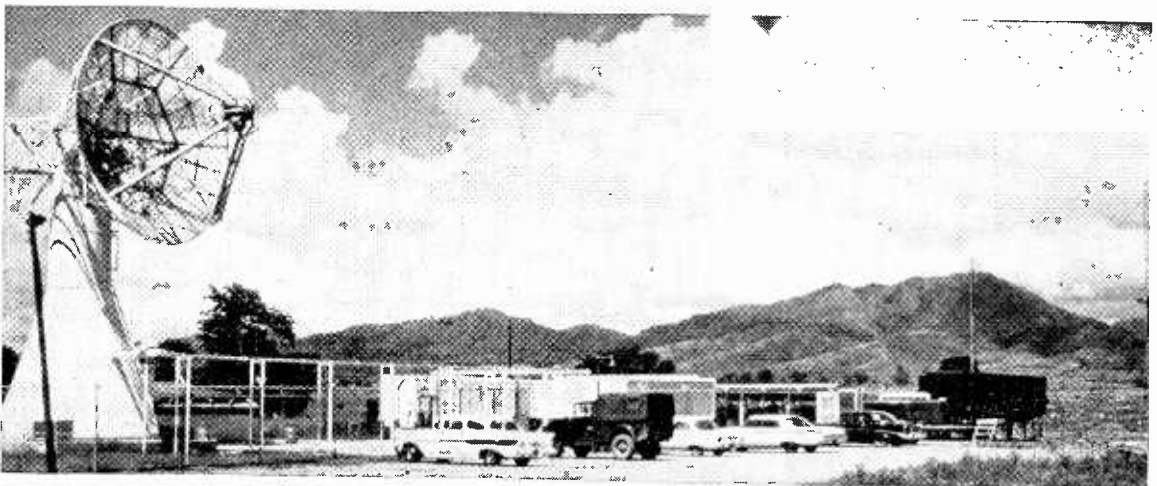

SOME OF OUR FRONT COVERS
FROM 1917-1961

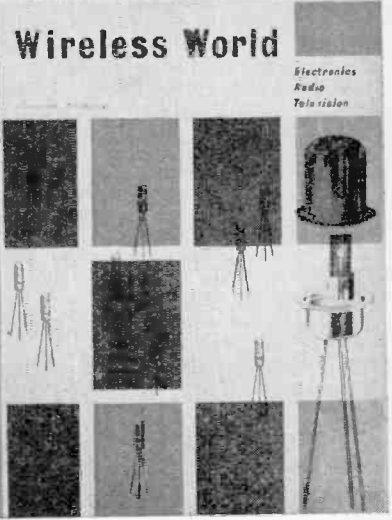
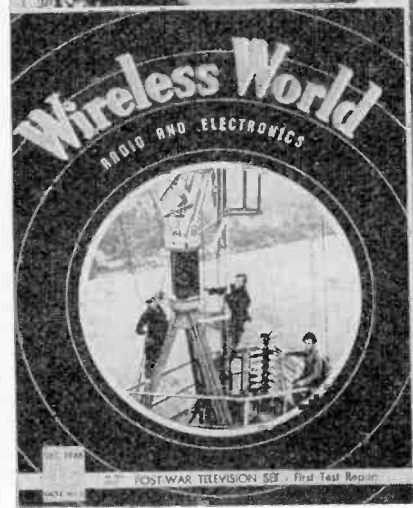
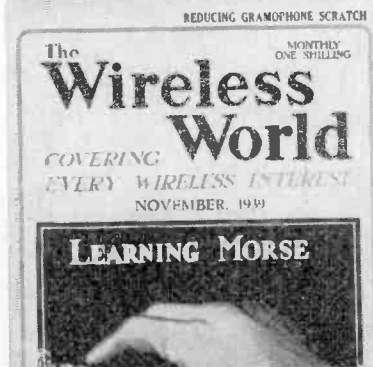
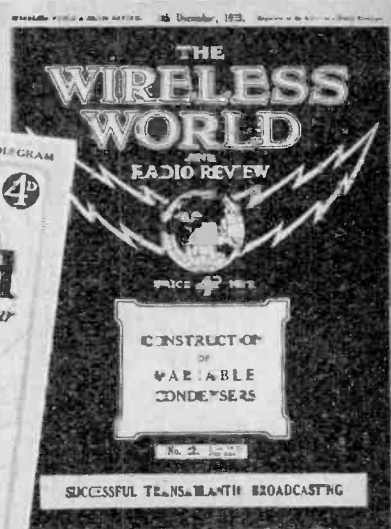
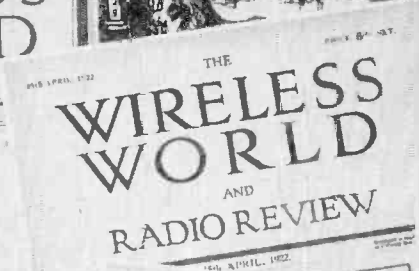
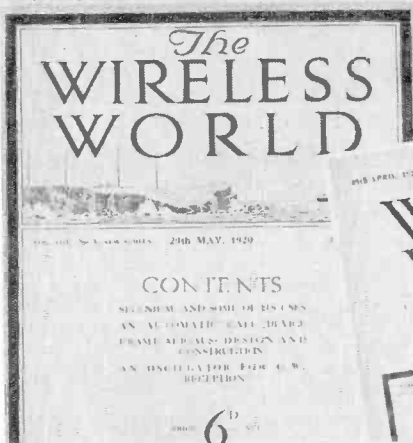
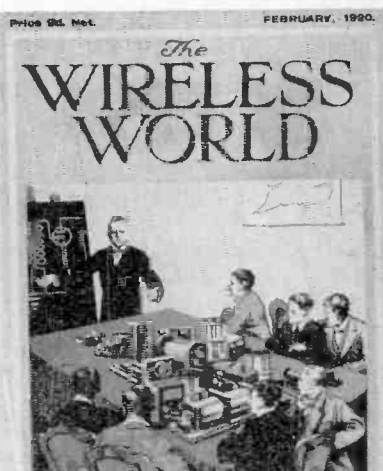
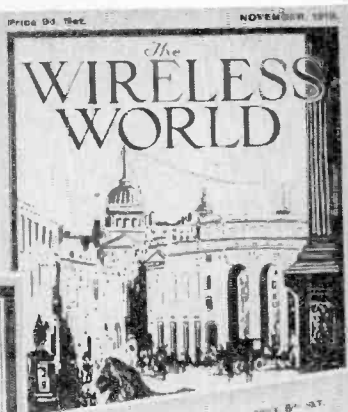
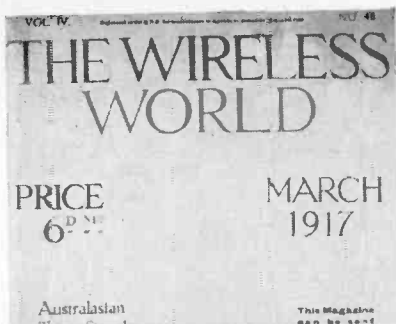

Tape Cassette for the Blind

NEW "TALKING BOOK" MACHINE



Tape cassette in position on its playing deck.

AFTER a thorough field trial in one hundred blind person's homes, a new "talking book" tape cassette reproducer will be introduced in a few months by the Royal National Institute for the Blind. It is hoped that this new tape reproducer will completely replace the present talking-book long-playing record reproducers within the next few years.

Apart from the usual advantages that tape has over disc of being more durable and less easily damaged, for this particular application tape has the additional advantage of enabling the recording and copying to be carried out by the Institute itself rather than by an outside company, so that there is less delay in providing "readers" with their choice.

In the new tape reproducer the speech is recorded on $\frac{1}{2}$ -in tape using 18 tracks. Up to 1,500ft of tape can be used in one "book," giving a maximum total playing time of 20 hours. The tape, the take-up and supply spools as well as the replay head are all housed in a cassette. In use this cassette is simply placed on the deck so that it engages with the tape drive spindle and is connected via a jack plug to the replay amplifier and loudspeaker.

The size of the whole cassette is kept down to only $8\frac{3}{4}$ in by $10\frac{1}{4}$ in by 2in by mounting the supply spool on top of the take-up spool. The tape passes from one side of the supply spool to the other side of the take up spool so that the tape which is momentarily on neither spool is slightly inclined to the horizontal. The tape is driven solely by the take-up spool which engages with the driving spindle when the cassette is placed on the deck: the supply spool is pulled round by the winding of the tape on to the take-up spool. Depending on the amount of tape on the take-up spool, the tape speed thus varies from about 3 to 7in/sec. This speed change does not alter the speech pitch since the recording is made with an equally-varying speed on the same cassette. The changing tape replay frequency response due to the same speed variation is compensated for by an opposite response when recording.

A recorded announcement indicates the end of each track. The listener then simply stops the drive mechanism, turns the cassette over so that the full take-up spool becomes the new supply spool, and then restarts the drive to replay and the next tape track.

Two safety devices operate should the listener not switch off at the end of the track. First, the track end recorded announcement is followed by a high-pitch whistle. The replay head output produced by this whistle is rectified and then used to cut off a valve whose anode current flows through the hold-on solenoid of the motor supply switch. When the valve is cut off this switch thus opens and stops the tape drive motor. The second safety device operates in the unlikely event of this whistle switch-off arrangement failing. It consists

simply of a slipping clutch on the take-up spool which prevents the tape from being pulled off the supply spool. Spring-loaded pads bear on the tape on the spools to prevent tape spillage if the spools are inadvertently hand wound in the wrong direction.

A portion of speech can be repeated by turning the cassette over, playing a portion of the next track (which is equivalent to winding back a portion of the first track) and then turning the cassette over again to replay the desired portion.

The tape replay head is mounted near the middle of a lever which is pivoted at one end and fitted with cogged teeth at the other. These teeth engage a spring-loaded ratchet wheel so that, when a button is depressed, the wheel advances one step and the head is moved opposite to the adjacent track. This must be done every second time the cassette is turned over on the deck. The head can be returned opposite to the first track by a relatively simple adjustment which does not entail opening the cassette. This would normally be done when the "book" is returned to the library, but could be carried out by a skilled user.

This tape reproducer is a development of the model described on page 32 of the January 1954 issue of "Wireless World."

Novel Hearing Aid

USING A "WIRELESS" EARPIECE

TELEX in the United States have recently developed a new type of hearing aid, called "Telex Radiant," that is actually a transmitter and receiver built into a pair of spectacles. A miniaturized transmitter located in the temple bows accepts sound waves, converts them into electrical energy and transmits them through the air to the receiver located in the ear. The receiver picks up the signal, amplifies it, and converts it back to sound waves in the ear canal. The "Telex Radiant" uses six miniature transistors.

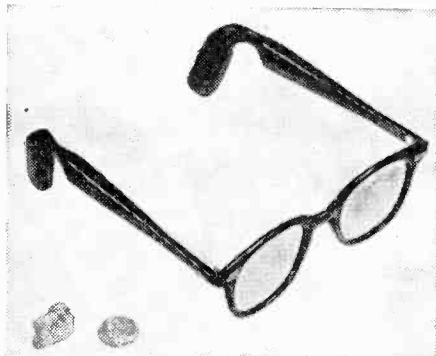

Pair of spectacles equipped with the "Telex Radiant" hearing aid. At the bottom left is shown the receiving unit: this is normally fitted inside the ear.

1.—BASIC DESIGN CONSIDERATIONS
CIRCUIT DETAILS AND
PERFORMANCE

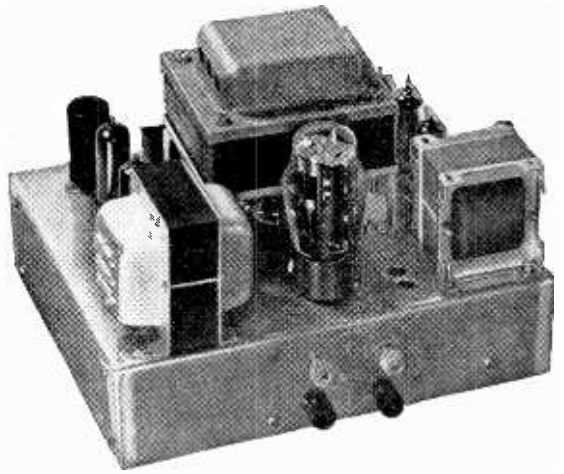

By E. JEFFERY, A.M.I.E.E.

LOW-COST STEREO AMPLIFIER

SOME years ago the writer published in this journal¹ a design for a high-gain phase-splitting circuit which, using only two valve stages, provided a gain to either output terminal of approximately 1,000. As an illustration of the principles described an amplifier design was also given using KT.66's as triodes in the output stage. Although intended essentially to be a design article many readers chose to regard the amplifier as a high-quality system (we didn't use the term "high fidelity" much in those days*) as it gave a distortion harmonic content of less than 0.5%.

The phase-splitting circuit was later used fairly widely in commercial amplifiers, e.g. the R.C.A. Orthophonic, and has also been used in the design of industrial equipment. Mullard have published a "starvation" version of the circuit², whilst more recently in this journal³ and in *Electronic Technology*^{4,7} A. R. Bailey has evolved single-ended versions of the circuit for special purposes.

Principle of the High-gain Circuit.—G. W. Short has recently surveyed⁵, very exhaustively, this and circuits of a similar nature, and it will only be necessary to restate the principles involved very briefly.

Let us first consider the circuit to the right of A-B in Fig. 1; the stage V2 has the general configuration of a divided load phase-splitter, the anode load is R_3 and the effective cathode load consists of R_2 in parallel with R_1 ; since h.t.+ and h.t.— are at the same a.c. potential, it is immaterial from the point of view of V2 whether the point C of R_1 is returned to the positive or to the negative rail. Consequently, if the value of R_1 and R_2 in parallel is made equal to R_3 then, for a given impressed voltage between A and B, the output voltages V_{o1} and V_{o2} will be equal. There is no *a priori* reason why R_1 and R_2 should be made equal but the author chooses to make them so to make the sums easier because then $R_1 = R_2 = 2R_3$ for equality of output.

From our general knowledge of such circuits we know that $V_{o1} (=V_{o2})$ will be slightly less than V_{AB}

since the grid-cathode voltage of V2 will be such that $V_{o2} = V_{AB} - V_g$.

If we choose a triode of the following characteristics for V2; $g_m = 8.5 \text{ mA/V}$, $\mu = 40$, $r_a = 5 \text{ k}\Omega$ and make $R_1 = R_2 = 100 \text{ k}\Omega$ and $R_3 = 50 \text{ k}\Omega$, then V_{o1}/V_{AB} will be about 10 or V_g will be about 1/11 of V_{AB} . Now R_4 and R_5 are in parallel so that the effective

grid—cathode impedance $R_g' = \frac{R_4 \cdot R_5}{R_4 + R_5}$. The current

flowing through this impedance will be $i_{in} = \frac{V_g}{R_g'}$

and this current is supplied from the anode circuit of V1. Viewed from A-B, the input impedance will be V_{AB}/V_g or, in terms of V_g , this impedance will be $\frac{V_{AB}}{V_g} \cdot R_g'$. We have already seen that $\frac{V_{AB}}{V_g}$ may be about 10 (actually 11 in our calculated case) so that the effective impedance presented to the anode circuit of V1 is some 10 times the physical grid-cathode impedance of V2.

The d.c. required for the anode of V1 sets a limit to the maximum permissible value of R_4 and these d.c. considerations will usually fix R_4 at a value from 100k Ω to about 1M Ω .

In our practical case $R_4 = 820 \text{ k}\Omega$ and $R_5 = 2.2 \text{ M}\Omega$ so that $R_g' = 598 \text{ k}\Omega$. We have also seen that V_{AB}/V_g may be about 10 so that the apparent input impedance to the right of AB becomes of the order $10 \times 598 \text{ k}\Omega \approx 6 \text{ M}\Omega$. As we have seen, this appears as the anode load to the pentode V1 and the value is in the same world as the a.c. resistance of the pentode. By this means we can realize a substantial proportion of the μ of the pentode as gain and since this μ may be very high (frequently of the order of $\times 5000$) it is possible to achieve a gain of the order of 3000 to either output point, without much difficulty.

Even with separate valve envelopes for V1 and V2, the circuit offers substantial benefits of gain over any other similar arrangement: the recent introduc-

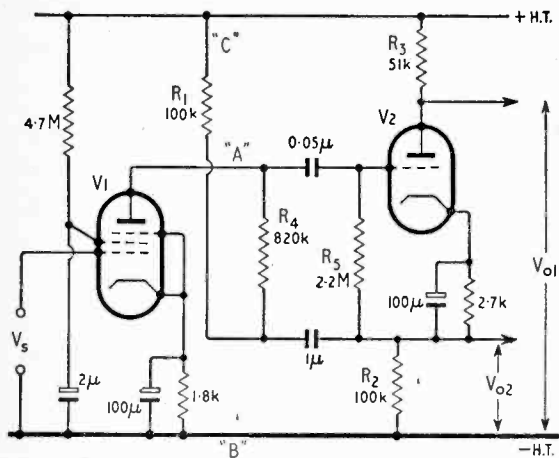

Fig. 1. Basic circuit of high-gain phase splitter.

tion of a suitable audio-frequency triode-pentode, the Brimar 6BR8, enables these benefits to be achieved in a single envelope. The values shown on the circuit of Fig. 1 do, in fact, relate to a 6BR8; with an h.t. supply of 300V the values shown give a gain of over 3000 times (to either output V_{o1} or V_{o2}). At 10V r.m.s. output the measured distortion was 0.6%. This distortion was almost entirely second harmonic in content. The a.c. and d.c. loads on V1 are very different and the circuit component values were therefore finally determined experimentally to give a reasonable compromise between the somewhat conflicting factors of gain and available output.

It will be seen that the circuit operates in a semi-starvation condition which has the effect of raising the available μ considerably above the value given in the relevant application report; the makers characteristics for the pentode portion are quoted as $g_m = 5.25$ mA/V and $r_a = 500k\Omega$ for a bias resistor of 80 ohms and a cathode current of 12.8mA. This gives a computed value of $\mu = 2600$, which is less than the gain which we can realize; it follows therefore that by operating the pentode stage in a lower current régime the available μ is significantly increased, in fact the anode current under our chosen condition of operation is less than 0.25mA. A circuit virtuoso could probably soar to even greater heights of gain in a cadenza on this theme.

In the practical application of this circuit some of the gain is deliberately thrown away in the interests of low frequency stability when negative feedback is applied over the whole amplifier, thus in the applied

version the bypass capacitor on V2 bias resistor is omitted.

Advantages of the Circuit.—It is, of course, easy to achieve the same total gain by other means using more stages but in addition to the obvious economy in valves and components there are substantial advantages to be obtained in achieving a large gain in as few stages as possible since this gain is thereby associated with a correspondingly smaller number of phase-shifting networks. This greatly simplifies the application of negative feedback over a whole amplifier system; in fact the real virtue of the circuit resides in this property and it is this which makes it most suitable for inclusion in a design which has to be constructed by readers who, for all I know, may not possess wide-range oscillators, phase-sensitive valve voltmeters, long persistence oscilloscopes or even transfer function analysers!

Comparison with Other Two-valve Phase-splitter Arrangements.—There are, of course, many other methods of connecting two (similar or dissimilar) valves in a phase-splitting arrangement; we must of course regard any two-valve combination in a single envelope as two valves for the purpose of the act.

The following table sets out the gains available with different valve combinations, for comparison purposes.

It is seen therefore that the circuit of Fig. 1 offers very substantial advantages of gain over any comparable arrangement.

Advantages of the Circuit for Stereo Use.—We have already seen that the circuit of Fig. 1 can save a complete valve compared with other methods of phase splitting, for equivalent gain; the saving of one valve has not tended to be a matter of prime importance in recent years but with the advent of stereo a possible saving of two valves becomes well worth having. It must be a matter of regret to manufacturers that only two channels were adopted for stereo but even so the ark-like need for two of everything is a strain on most pockets.

The high gain permits another substantial benefit, however. As designed, a gain of well over 2,000 is obtained from the phase splitter; if we use the circuit to drive EL84s which requires 8V r.m.s. grid drive, the input signal without negative feedback is some 3mV; when overall feedback of 20dB is applied the overall sensitivity is better than 40mV. This enables the relatively insensitive ceramic type of pickup to be fed directly into the main amplifier and, if desired, it is possible to dispense entirely with a pre-amplifier.

The author is of the opinion—and will no doubt live to regret it in the correspondence columns—

Valve Combination	Triode + Triode	Triode + Triode	Triode + Triode	Pentode + Triode	Pentode + Triode
Typical Valves	ECC83 (both sections)	ECC83 (both sections)	ECC83 (both sections)	EF86+ EF86 (as triode)	6BR8 (both sections)
Method of Connection	Triode amplifier + divided load splitter	See-saw	Schmitt (long-tailed pair) or cathode-coupled	Pentode amplifier+ divided load splitter	As in Fig. 1
Gain	54	62	27	200	3500

Fig. 2. Block diagram of either channel of stereo power amplifier.

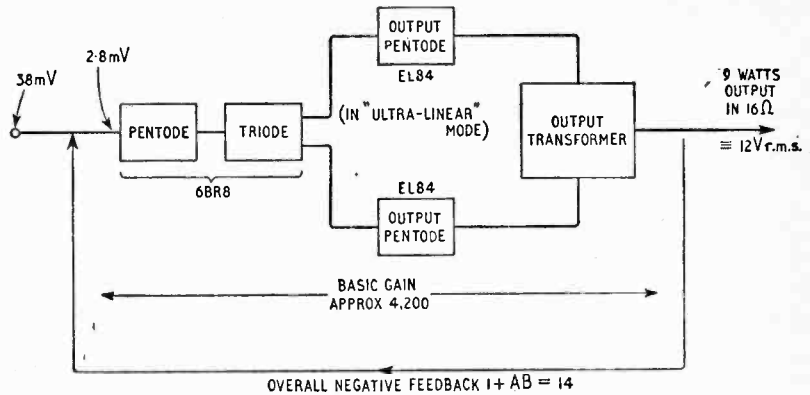

that with a good pickup and loudspeaker system the modern pre-amplifier with its multiplicity of possible settings is more trouble than it is worth. One example has 14 panel controls alone, if we assume that a 2dB change of level is just discernible on the tone controls then there are some 1,200 possible combinations of tonal quality alone for a given volume, and the probability of the domestic user selecting the optimum setting is low. If any reader doubts this suggestion let him play the same record on different days and on the two occasions let him set the controls with his eyes shut; the comparison, even of volume setting, will be a little daunting. We also have it on the excellent authority of Mr. P. J. Walker that "With a very good loudspeaker it should seldom be possible to improve the balance professionally achieved at the transmitting studio." Even the impressive unit referred to earlier, which aims to be all things to all men, is not really complete as no provision is made for equalizing Edison Bell cylindrical records.

For those who do wish to have auxiliary bass and treble controls the amplifier sensitivity is sufficient to permit the insertion of passive networks between a crystal or ceramic pickup and the amplifier.

One final advantage associated with the saving of two valves is, of course, the reduction in total size, which can significantly affect the cost of the cabinet or enclosure required.

Design of a 9W+9W Amplifier

The circuit has been applied to the design of a 9W + 9W Stereo power amplifier using EL84s in the "ultra-linear" mode as the output stage, a block schematic of either channel is given in Fig. 2.

Although the output valves are nominally rated for 11 watts output the author has the same trouble as a previous contributor, G. W. Short, for whom circuits never do what the manufacturers or designers claim, and has, therefore, deliberately down-rated the amplifier output. He also holds another heretical

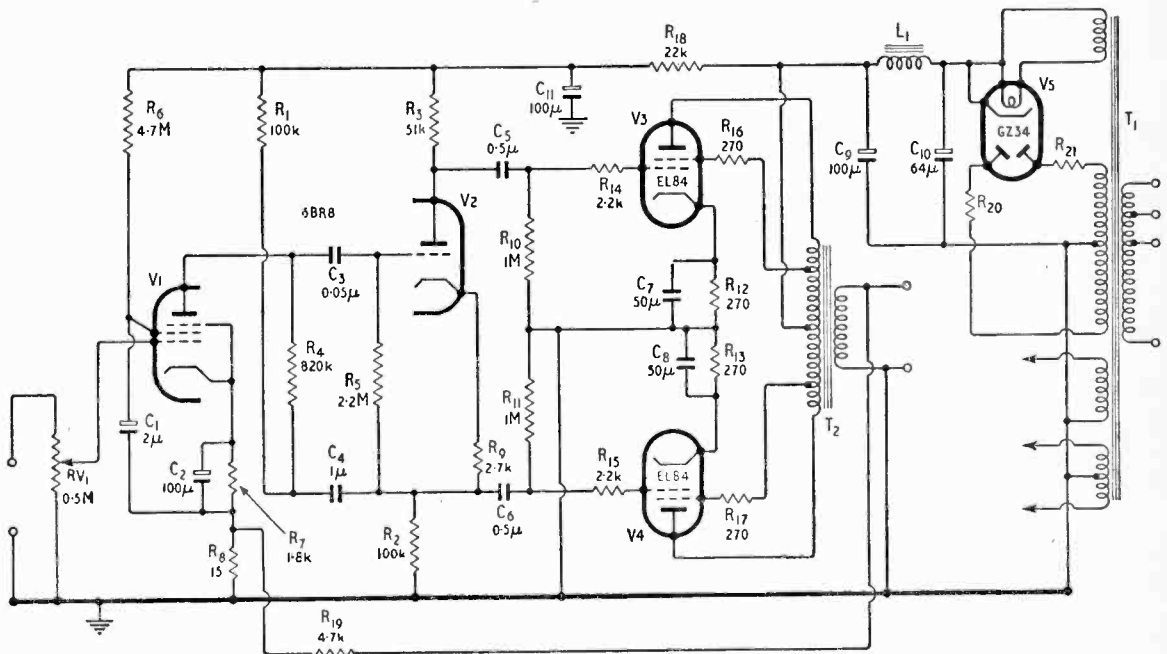

Fig. 3. Circuit diagram of either channel of power amplifier and power supply unit for both channels.

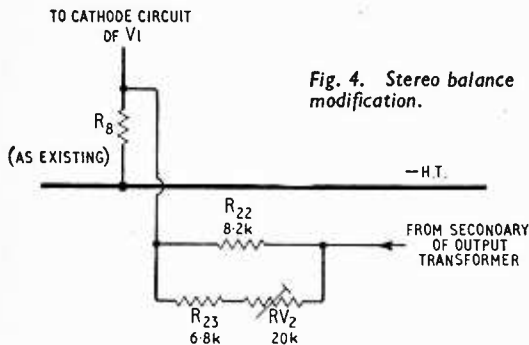

Fig. 4. Stereo balance modification.

belief, that amplifiers should give something like the designed performance, even when only unmatched valves are available and without the need for setting phase-splitter balance controls.

The complete circuit for a single channel together with the power supply system required to serve both channels is given in Fig. 3.

V1 and V2 constitute the pentode and triode sections respectively of a 6BR8 and as pointed out earlier the circuit differs slightly from Fig. 1 in that there is no bypass capacitor across the bias resistor of V2. In this form the gain of the phase-splitter from the V1 grid to either output grid, including the loading effect of the resistor R_{10} (or R_{11}) was measured to be 2,300, a number of prototypes produced values of gain within 10% of this value without any special precautions in the selection of components.

Overall negative feedback is derived from the secondary of the output transformer and applied through the feedback resistor R_{18} to resistor R_8 in the cathode circuit of V1. The average overall gain of the system from V1 grid to the output transformer secondary load is some 4,200 so that, for a

feedback ratio $B = \frac{R_8}{R_8 + R_9} = \frac{15}{4,700 + 15} = \frac{1}{314}$, the

calculated feedback factor $1 + AB = 1 + \frac{4,200}{314} = 13.4$ which is equivalent to 23dB. This compares very well with the measured value of 23dB.

Stereo Balance Arrangements.—A number of factors operate which can lead to an overall difference in the acoustical performance between the two channels, in particular:

- The ideal siting of loudspeakers may not be feasible in domestic surroundings.
- It is quite usual to create a stereo system from existing "bricks" and this may lead to the employment of loudspeakers which have different characteristics.
- There may be differences in the basic sensitivity of the pickup between the two channels.

It is usual therefore to provide some method of adjusting, on a pre-set basis, the balance, or relative, gains of the two channels.

The best method of achieving this depends on the overall system chosen and therefore two alternatives are offered.

If no pre-amplifier is used.—In this case the control RV_1 and its counterpart in the RH channel will be two sections of a ganged volume control, and this control will be the main volume adjust-

ment of the system. The balance control can then take the form of an adjustment of one of the channel amplifier feedback resistors. Since the range of adjustment is small (about $4\frac{1}{2}$ dB) and since there is a generous margin of stability in the amplifier the adjustment needed makes no significant difference to the designed performance.

To provide the variation required the feedback resistor R_{19} on one of the amplifiers is replaced by the arrangement of Fig. 4.

If a pre-amplifier is used the main volume control will normally be associated with the pre-amplifier so that the input volume control RV_1 of Fig. 3, and its related component in the RH channel, will be redundant. Two methods of providing the stereo balance adjustment are, therefore, available:

- An adjustment of one channel can be provided as shown in Fig. 4, in which case the input volume controls can be replaced by fixed resistors of say $1M\Omega$,
- the input volume controls can be replaced by ganged logarithmic/antilogarithmic potentiometers following the 10% law. In this system the LH channel is connected to a logarithmic potentiometer reversed, and the RH channel is connected normally to antilogarithmic potentiometer as shown in Fig. 5. This method has the advantage that no internal modification to either amplifier is required and the insertion loss of the balance circuit at the mid-position is less than 1dB.

The gain adjustment is then differential over the whole range of maximum to minimum, but in practice this wide range of adjustment can sometimes be an embarrassment and of course the cost of this type of control is considerably higher than the simpler arrangement of Fig. 4.

Power Supply Unit

The power supply unit is common to both amplifiers and consists of a standard mains transformer feeding a GZ34 rectifier operating in the capacitor-input condition.

Although in recent years there has been a tendency to adopt resistor-capacitor smoothing for small amplifiers, in this instance choke-capacitor smoothing has been adopted for the following reasons:

- The combined current of the two amplifiers is quite high (approximately 180mA) and common resistive smoothing would not be practicable.
- The regulation of the h.t. system is not significantly affected by drawing current for a pre-amplifier or tuner unit.

A single heater supply has been provided to feed all valves in the main amplifiers (other than the rectifier). This supply is earthed on one side and there may be some further advantage, from a hum point of view, if a true or artificial centre tap were provided. A separate heater winding is provided for use with a pre-amplifier or tuner unit. If this supply is used alternatively for a pre-amplifier or tuner unit care should be taken to ensure that the earthing arrangements cannot lead to a short circuit, as some commercial f.m. tuners have internal earth connections to the heater circuit.

The h.t. circuit is capable of providing a current up to 20mA to a separate pre-amplifier or tuner. Any auxiliary unit should have its own adequate decoupling circuits to ensure that the overall system remains stable.

To simplify the construction of the amplifier all the smoothing electrolytic capacitors are provided in the form of two 64 + 100 μ F units. The 64 μ F portion of the can mounted in the LH portion of the chassis serves as the rectifier reservoir and the associated 100 μ F section acts as the choke filter capacitor. The other can provides the 64 μ F for smoothing to the early stages of the LH amplifier and the 100 μ F serves the same function to the RH channel. There is no significance in the difference in value, the selected components are combined in this particular way and there is no measurable difference in the 100-c/s hum level between the two channels of the amplifier.

Measured Performance of the Amplifier

The following measurements were taken on one channel of a representative prototype with the overall negative feedback applied.

Input Sensitivity.—38mV at 400c/s applied to the input produced 12V across a 16-ohm load connected at the output transformer secondary.

Power Output.—With the conditions given in the foregoing paragraph, the 12V across a 16-ohm purely resistive load was equivalent to 9W power output.

Distortion.—At 9W power output in the 16-ohm

Harmonic order	2nd	3rd	4th	5th	6th	7th	8th	9th
Distortion % ..	0.073	0.041	0.068	0.056	0.020	0.024	0.030	0.029

Total r.m.s. distortion 0.13%

load the following distortion products were measured (again at 400c/s input).

Gain Frequency Response.—The overall response was ± 1 dB from 10c/s to 20,000c/s.

Hum Level.—The total r.m.s. hum level was 80dB down on maximum output.

Channel-to-Channel Crosstalk.—When measured with the input to each channel short-circuited, the channel-to-channel crosstalk at 400c/s was better than 74dB. At 1k/c/s the crosstalk was 66dB whilst at 10kc/s a value of 48dB was measured.

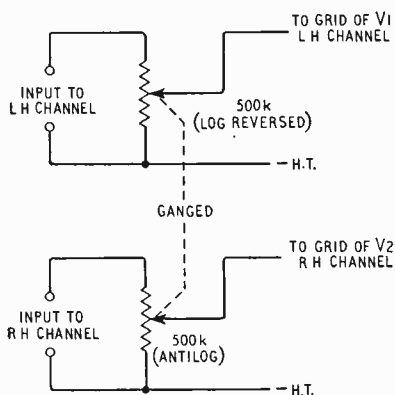

Fig. 5. Alternative stereo balance circuit.

Balance of Channel Gains.—The overall gains of the left-hand, right-hand channels with the gain controls at maximum were within $\frac{1}{2}$ dB of each other (this was also true when dissimilar transformers from different manufacturers were used in the two channels).

Additional Measured Data.—Other measurements taken, including internal measurements on the phase splitter and the overall loop gain characteristics, are given in Appendix I.

Comment on Measured Performance.—The measurements relate to a typical prototype; by selection of output valves and accurate adjustment of supply voltages it was possible to improve the distortion content to less than 0.1%, on the other hand the worst combination of available valves and output transformer gave 0.24% total distortion.

One of the most important features of any amplifier is its ability to perform adequately under conditions other than those obtaining in the closely controlled world of measurement. A. J. Kander suggests⁶ that all amplifiers should be stable under conditions ranging from half the nominal load impedance up to open circuit and also suggests that the amplifier should be stable with 0.1- μ F in shunt with the load. He finds, however, that many "amplifiers seen by the author have not been capable of meeting such a stability test."

One famous amplifier at least is known to dislike the shunt capacitance of long loudspeaker leads and by the geographical limitations which stereo imposes it is often necessary for loudspeaker leads to run considerable distances.

The present amplifier has, therefore, been checked for stability under the following load conditions:—

(a) A pure resistive load from zero to infinity (in fact the author uses an identical amplifier as part of a power oscillator which is frequently fed into an open circuit).

(b) A number of loudspeakers of impedance from 3 ohms to 15 ohms, including units with built-in crossovers.

(c) A 15-ohm load shunted by a 0.5 μ F capacitor.

The amplifier was found to be completely stable under all these test conditions. By using high-stability, close-tolerance resistors in the feedback circuits the gains of the two channels are very closely controlled (a maximum deviation of $\frac{1}{2}$ dB between prototypes was recorded). It is unlikely that the basic gains will need resetting as a 4dB change of internal gain results in an overall change of gain of only $\frac{1}{2}$ dB, such a change would normally be the symptom of some discernible catastrophic condition.

(To be continued.)

The next instalment will deal with constructional data, and will give guidance on various alternative input circuits including, where necessary, pickup equalizers and pre-amplifiers.

REFERENCES

- "A New High-gain Push-pull Phase Splitter Circuit," E. Jeffery, *Wireless World*, Aug. 1947, pp. 274.
- "High Stage Gain at Low Frequencies," *Mullard Technical Communications*, No. 6, Jan. 1954, pp. 137-141.
- "Economical High-Gain A.F. Amplification," A. R. Bailey, *Wireless World*, Jan. 1960, pp. 25-7.
- "Low-distortion Sine-wave Generator," A. R. Bailey, *Electronic Technology*, Feb. 1960, pp. 64-7.

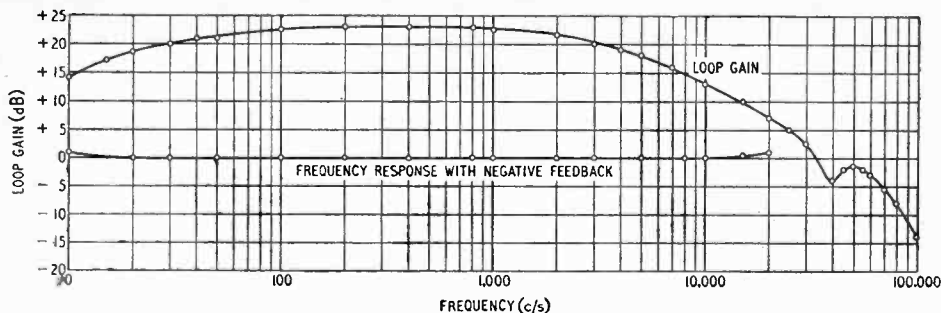

Fig. A.

- ⁵ "The Bootstrap Follower," G. W. Short, *Wireless World*, Jan., 1961, pp. 21-5; Feb., 1961, pp. 79-82.
- ⁶ "Universal Feedback Amplifier Circuit," A. J. Kauder, *Audio*, Jan. 1960, pp. 19-21.
- ⁷ "The Bootstrap Amplifier", W. Tusting, *Electronic Technology*, Jan. 1961, pp. 27-31.

APPENDIX I

Additional Measurements on Stereo Amplifier.

1. The frequency response and loop gain characteristic of the amplifier are given in Fig. A.
2. Distortion before overall negative feedback is applied. Measured at 400 c/s with 12V r.m.s. across the 16-Ω output load.

Harmonic order ..	2nd	3rd	4th	5th	6th	7th	8th	9th
Distortion %	0.71	0.24	0.38	0.35	0.22	0.19	0.16	0.14

Total r.m.s. distortion = 0.98%

3. Sensitivity before negative feedback is applied. 1.09 mV input at 400 c/s gave 4.9V output. (i.e. overall gain at this frequency ≈ 4500).
4. Hum levels before negative feedback is applied. At 50 c/s 21mV or 55 dB below maximum output. At 100 c/s 7mV or 63 dB below maximum output. At 150 c/s 8.3mV or 63.5 dB below maximum output.
5. Measurement of phase-splitter output. (a) Distortion at V3 grid with 12V output across 16-Ω output load, at 400 c/s i.e. approx. 8 r.m.s. at grid.

Harmonic order ..	2nd	3rd	4th	5th	6th	7th	8th	9th
Distortion %	1.0	0.21	0.09	0.19	0.19	0.14	0.11	0.10

Total r.m.s. distortion 1.08%

(b) Distortion at V4 grid under conditions set out above.

Harmonic order ..	2nd	3rd	4th	5th	6th	7th	8th	9th
Distortion %	1.39	0.37	0.39	0.28	0.27	0.28	0.25	0.19

Total r.m.s. distortion 1.6%

(c) Grid-to-grid unbalance at 400c/s = 1.02% (This figure will inevitably depend on the resistor equality in the loads on V2.)

A note on a.c. voltage and harmonic distortion measurement.

The author has noted a tendency to imply accuracies of a.c. measurement which are not realizable with commercial equipment, e.g., the excellent Avo Model 8 has an accuracy of ±2½% of full scale on the a.c. voltage ranges and power measurements are therefore liable to a ±5%

error. The best commercially available valve voltmeter claims an accuracy of ±1% (of full scale) although in fact the indicating meter fitted has itself this degree of inaccuracy. Elaborate precision laboratory equipment is needed to achieve better results than this. The author's distortion percentages are computed from ratios of fundamental and harmonic voltages and for this reason are liable to the errors of a.c. measurement.

"Wireless World" Books—New Editions

Principles of Transistor Circuits (2nd Edition) by S. W. Amos, B.Sc.(Hons.), A.M.I.E.E. The author, who is Editor of the Technical Instruction Section of the B.B.C. Engineering Department, has revised completely and brought up to date the first edition, incorporating six new chapters. Starting with a clear, simple exposition of the physical principles on which the operation of semiconductor devices depends, a lucid and logical development leads to consideration of the factors affecting the use of transistors and other semiconductor components in equipment. Principles are illustrated by reference to typical circuit applications, including f.m. receivers and pulse techniques. The author's final chapter deals with some of the recently-developed devices such as the tectron, tunnel diode and controlled silicon rectifier. Pp. 211 with 125 diagrams; price 21s (by post 22s).

Learning Morse.—First published in 1939 and now in its 13th edition this guide to a mastery of the international telegraph code contains the Morse alphabet, numerals, punctuations and other commonly used signs. It explains how to hold and operate a telegraph key in the easiest way and contains a description of a simple transistor oscillator for practising and teaching the code. Included also is the revised "Q" code abbreviations approved at the 1959 International Radio Conference at Geneva. Pp. 20 with 7 illustrations. Price 1s 6d (1s 9d by post).

Both books are published for *Wireless World* by Iliffe Books Ltd., Dorset House, Stamford Street, London, S.E.1.

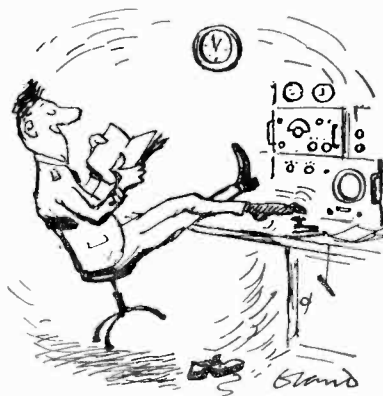

This method is not recommended in "Learning Morse."

International Semiconductor Symposium

Colloque International sur les Dispositifs à Semiconducteurs—Paris, 20-25 February, 1961

ORGANIZED by the Society of French Electronicians and Radioelectricians (S.F.E.R.) and under the patronage of the National Federation of Electronic Industries (F.N.I.E.) this colloquium followed the French Components Exhibition (in fact the two events overlapped by two days). More than 900 participants from all parts of the world attended. There were 140 lectures and discussions in three concurrent sessions, two in the UNESCO building and the third in the adjacent headquarters of the French P.T.T. Many supplementary discussion groups were organized spontaneously by specialists. The success of the symposium was proved by the attendance which was sustained to the end.

The main purpose of the conference was the exchange of ideas on the possibilities and limitations of semiconductor devices, and to promote a better understanding of the points of view of manufacturers and users. To this end the papers were grouped under three main headings, with various sub-divisions. (The figures in brackets indicate the number of papers in each section.)

Production. H.F. transistors (11); power transistors (6); miscellaneous transistors (6); p-n-p-n diode and triode switching devices (5); tunnel effect devices (7); parametric diodes (3); photo-diodes, solar cells (7); thermo elements (7); miscellaneous techniques (7); miscellaneous devices (8).

Applications. Thyratrons (8); pulse circuits (9); amplifying and oscillating circuits (10); "equipments" (4); measurement (7); micro-electronics (4); tunnel diode applications (6); new devices (4).

Reliability. General (4); physical data and technology (7); methods of measurement (5).

Inevitably in such a rapidly developing subject as semiconductors, rigid classification was impossible and many papers seemed to sit uneasily in the sessions to which they had been assigned. The following notes are intended to give an impression of some of the highlights rather than a balanced survey of the conference, for which prolonged study of the published papers and discussions will be necessary.

All lectures containing any reference to mesa structures or to epitaxial techniques (the growth of very thin layers of high resistivity material by vapour deposition in which the new layer continues the crystalline alignment of the substrate) were well attended in the hope that something might be disclosed in the way of new manufacturing recipes and "cooking." Undoubtedly the customers learned much, but some of the "chefs" to whom we spoke did not think that their colleagues had been particularly communicative. Undoubtedly a lot of work is being done in gallium arsenide and other intermetallic compounds for use in transistors and diodes but much of this is clearly of an experimental nature and there are as yet no signs of their general adoption in production. Sintered semiconductor thermo-elements are not isotropic according to M. Alais and G. Fournet (Soc. Alsacienne de Constructions Mécanique) who showed that the figure of merit, as defined by thermo-electric power and thermal and electrical conductivity, is greatest at right angles to the direction of application of pressure during the forming process. Double-diffused transistors of the planar (as distinct from the mesa) type were reported by V. H. Grinich (Fairchild Semiconductor Corp.) in which the active base region is limited by masking with a film of silicon oxide using a photo-lithographic process to define the surfaces exposed for treatment. After diffusion all

the exposed surface is completely re-covered by a re-grown SiO_2 layer which prevents contamination and gives mechanical protection when the transistor is encapsulated in "micro" circuit elements. A comparable technique was described by Fromageot, Michelet and Saintesprit (Lignes Télégraphique et Téléphonique).

Among special-purpose junctions the most interesting were those designed for the detection of nuclear radiation. These give rise to electron-hole pairs in the depletion layer and a ray counter junction of n-i-p type, described by Mme L. Koch and J. Messier (Centre d'Etudes Nucleaires de Saclay) has made possible the detection of individual gamma rays. Modification of the collector junction reverse current in l.f. transistors (e.g. OC72) due to flaws in the material has been used by J. Bok and R. Schuttler (Centre d'Etudes Nucleaires à Fontenay-aux-Roses) to measure neutron flux. Irradiated transistors of this type can be used to measure gamma radiation in the presence of neutron fluxes below that of the maximum irradiation.

Germanium grain boundary photocells of high sensitivity and extremely small size (smaller than a light spot can be focused) were described by Dr. H. A. Schell (Te-Ka-De), and field effect transistors utilizing grain boundaries and having a negligible temperature coefficient at low temperatures were discussed by H. F. Matare of the same company.

The papers on micro-circuit techniques were well attended. A somewhat more sober approach, with a revision of early astronomical estimates of packing densities for components, was evident; no answer was forthcoming to the problem of interconnecting micro-units in large and complex combinations. Research on the simulation of inductance by impedance inversion and multiplication by means of diode and transistor circuits was reported by Nishizawa, Kojima and Yoneyama (Tohoku University, Sandai) who have obtained stable impedances equivalent to 1H and 100 μF . The importance of these devices, which do not involve magnetic fields, and therefore unwanted couplings, in micro-circuits are obvious. The future of micro-circuits and indeed of the extension of semiconductor techniques in general towards higher frequencies and faster switching times seems now to rest with tunnel diodes which are cheap to produce, have fewer connections and are therefore more reliable, and are immune from surface effects and more suitable for encapsulation in micro-circuit modules.

The symposium was honoured by the presidency of Prince Louis de Broglie who, in his opening address, traced the development of atomic physics and its bearing on semiconductor theory with the lucidity and simplicity which is characteristic of the greatest scientific minds. Cogent speeches were contributed to the opening session by M. R. Gueur (chairman of the organizing committee), M. Jeanneney (Minister for Industry) and General Guerin (chairman of the S.F.E.R.) who described the recent rate of development as "explosive," the result of a "chain reaction between research and application in industry."

In the space available it has been possible to touch only on some of the highlights of the symposium, but the full proceedings will be printed and will be available to non-participants in two or three months' time from the Société Française des Electronicians et des Radio-electriciens, 10 avenue Pierre Larousse, Malakoff (Seine), at a cost of about 150NF (£11).

LETTERS TO THE EDITOR

The Editor does not necessarily endorse the opinions expressed by his correspondents

Bootstrap Follower Amplifier

In the January issue of *Electronic Technology*, W. Tusting gives an interesting theoretical analysis of the low-frequency response of this type of circuit. If the lower coupling capacitor (C_3 in my Fig. 9, p. 79, February *Wireless World*) is very large compared with the upper one (C_2), then the l.f. response of a typical circuit is similar to that of a normal amplifier with one RC coupling. Mr. Tusting says that, generally speaking, it will suffice to choose the main coupling (C_2R_5) so that it alone will give the required response, and then make the lower capacitor about 50 times as big as the upper one. This looks like a useful rule of thumb. It may seem surprising that it is necessary to choose C_2 and R_5 so that they will give the required response in the absence of any impedance multiplication. When C_3 is large enough R_4 is effectively returned to the cathode of V2, however, and because of this the time constant C_2R_5 is unaffected by feedback.

If the lower capacitor is appreciably less than 50 times as big as the upper, a step appears in the l.f. response. In the example given, the response levels out after an initial drop of about 7dB, remains level as the frequency is reduced, then falls again, at very low frequencies. This type of response is undesirable in a straightforward amplifier, but Mr. Tusting points out that it may be useful in a negative feedback amplifier because the l.f. phase shift is less than that of the ordinary RC coupling (C_2R_5) alone.

The writer has confirmed the existence of the step in the l.f. response by experiment.

Croydon.

G. W. SHORT.

THIS circuit has received considerable attention from the technical press this year, and additional analytical treatment appears in *Electronic Technology* (January 1961), as well as in the January and February issues of this journal. However, I find it difficult to accept certain explanations of its behaviour.

First, a.c. coupling to the cathode follower is not essential. Secondly, the high input impedance of the cathode follower is not primarily responsible for the substantial increase in gain of the pentode. I would suggest that the bootstrapping is merely a form of positive feedback, or servo assistance.

It is well known that if the anode load of a pentode

valve be progressively increased the gain ceases to rise appreciably because of the fall in anode current, and mutual conductance. The h.t. supply has to be progressively increased to avoid this effect which is frequently uneconomical, and moreover the valve ratings may be exceeded. In the bootstrap circuit the cathode follower regulates the h.t. supply to the pentode (junction of R_{LP} and R_{LC}) at signal frequency and in phase with the output of the pentode. This may be regarded as positive feedback, and the cathode follower is able to do this because of its low output impedance.

The accompanying circuits illustrate these points and a circuit which I have used for some time. It yields a gain of 2,500 with complete reliability. Other readers may be interested to know that this type of circuit has also been discussed by Mr. A. W. Keen in a paper entitled "Bootstrap Technique" (*Electronic & Radio Engineer*, Sept, 1958).

An EF86 and half a 12AT7 in one envelope would be very useful in low level audio circuits because the signal-to-hum ratio would be superior to the 6BR8.

It has, like the cascode amplifier, the advantage of high gain with a single phase inversion, but in contrast a lower output impedance. For this reason the circuit may also find application as a time base or shunt amplifier circuit in an h.t. stabilizer.

Sevenoaks.

J. R. OGILVIE.

The author replies:

It is certainly possible to regard the bootstrap follower as an amplifier containing a positive feedback loop. This does not clash with the approach used in my article: it leads to precisely the same results for the overall performance of the circuit.

Personally I prefer not to stress the positive feedback, because there is also a negative feedback loop, and, with resistive circuit components, the negative feedback always predominates. It is impossible for the positive feedback to make the circuit unstable, because the most it can do is to counteract the negative.

It seems simpler to treat the circuit just as a "circuit," without harbouring any preconceived notions about it, than to begin with the assumption that the triode is a true cathode-follower with 100% negative feedback, and then allow for the effect of the reduction of this negative feedback by the potential divider in the triode grid circuit. (Or, taking Mr. Ogilvie's standpoint, to allow

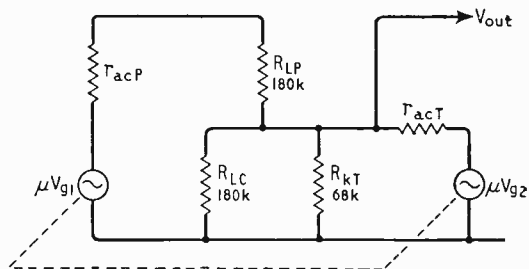
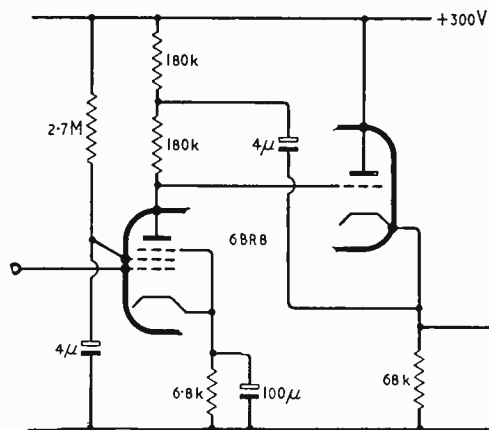

for the application of positive feedback by the same means.)

Mr. Ogilvie's circuit uses the same type of interstage coupling as my experimental phase-splitter (February issue, p. 82, Fig. 17). It is gratifying to learn that he has found it completely reliable. He does not, however, say anything about the frequency response of his single-ended high gain circuit. The amplification factor of the 6BR8 pentode is 2080 (with $I_a=10$ mA) so his circuit must be operating near the performance limit!

G. W. SHORT.

Aerial Models

IN his article entitled "Practical Aerial Measurements" in the December, 1960 issue, Mr. F. C. Judd includes many useful points of practical nature. It may be helpful to add certain others which have arisen during the installation of a similar aerial model table at the Royal Military College of Science.

The reciprocity principle implies that the radiation pattern of an aerial system is the same for transmission and for reception. One may, therefore, use the model aerial either as a transmitter or as a receiver. The first alternative demands and r.f. coupling between klystron and aerial to permit continuous rotation through 360° ; whereas if the model aerial is used as receiver, the crystal diode may be built into its base and simple slip rings may be used to pass the a.f. modulation to the subsequent amplifying stages.

When the author refers to "the use of scale models . . . for determining performance under working conditions," his definitions of "model" includes not only the correct scaling of the aerial under test, but equally faithful reproduction of site obstacles, as shown in the photograph at the foot of page 581. Three points arise in this context, which must be borne in mind in determining the construction and the dimensions of the "V" frame carrying (in Mr. Judd's case) the receiving aerial:

(i) The use of a nearby receiver implies spherical-wave rather than plane-wave geometry, and if the resulting phase discrepancies are to be kept below 45° , the receiving aerial must be at a distance greater than a^2/λ from the nearest point on the model, where a is the width of the complete model (i.e., the test aerial together with the site obstructions).

(ii) The receiving aerial must itself have a radiation pattern sufficiently uniform to "see" the complete model; otherwise reflections from site obstructions near the extremities of the model will be unduly attenuated.

(iii) The "V" frame itself should be constructed in such a way as to minimize additional reflections from its legs. We have used legs of triangular cross-section and have coated their inclined surfaces with Aquadag; thus reflection from the frame legs is not only cut down in amplitude but is also directed away from the receiving aerial.

For his receiver, the author uses a simple crystal-audio system, but we have found this technique to be inadequate for a very fundamental reason. One normally assumes square-law operation for the receiver crystal and, therefore, regards the crystal current reading (after appropriate amplification and demodulation) as a direct measure of received power. Unfortunately crystal performance checks show that this law does not hold good over the 20dB range which is essential if one is to evaluate satisfactorily the side lobes of many practical aerials.

The accompanying figure shows readings taken on a batch of five CV 111 crystals newly drawn from store. The scales are logarithmic, so that a square law would appear as a straight line parallel to the line PQ. Even greater departure from square law behaviour was found in the case of CV 102 crystals which had been in use for several months.

Errors arising from this cause may be avoided by operating the crystals at a fixed power level, and two methods have been widely used to accomplish this. In

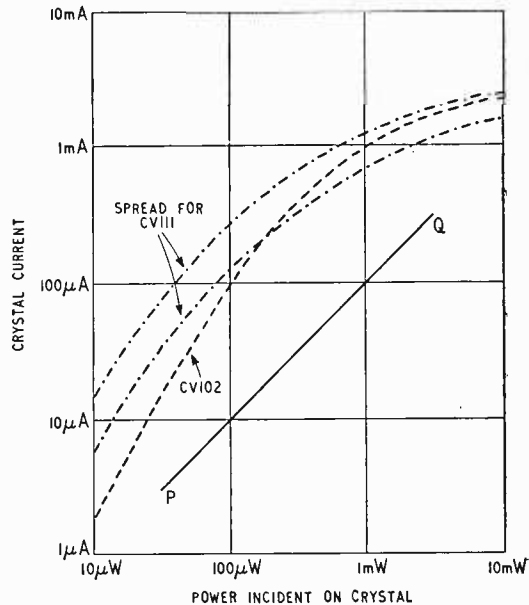

the first, a piston attenuator adjusts the transmitter output so that the received power always remains at a fixed level. Such an attenuator may, indeed, be servo-controlled from the receiver, the driving shaft being coupled to a pen recorder to facilitate automatic operation. Alternatively, normal superheterodyne techniques may be used, with a second klystron serving as receiver local oscillator.

The power incident on the crystal remains effectively constant, provided the local oscillator delivers a signal substantially greater than that picked up by the receiving aerial. One may either feed the receiver output to a normal p.p.i. display to permit inspection or photographic recordings, or one may meter and record receiver output in the normal way.

J. LAIT.

Principal Lecturer,
Radar & Telecommunications Branch,
Royal Military College of Science.

Shrivenham, Wilts.

Transatlantic Radio Telegraphy

NO doubt A. M. Humby is right in saying (March issue) that the long-distance l.f. stations, even when at their zenith in 1924, never managed to carry more than a very small proportion of world traffic. But I think he does rather less than justice to the pioneer stations Clifden and Glace Bay which, 50 years ago, maintained what appears to have been remarkably consistent transatlantic communication.

A tribute to the service was paid in 1912 by an apparently satisfied user, the *New York Times*, which was then receiving its European news telegrams, running at about 25,000 words weekly, by the Clifden—Glace Bay route. Refuting allegations by a cable company that the news was so much delayed as to be no longer "live," the *New York Times* issued a table showing average delays of under two hours*. Much of that delay was ascribed to the long and indirect landlines but, even so, results compared well with the cable service.

The Clifden circuit was still without a long-range rival in 1913, when the Government-appointed Parker Committee reported "practically continuous" communication.

Chichester, Sussex.

H. F. SMITH.

* See *The Marconigraph*, April, 1912, p.23.

Paris International Sound Exhibition

NEW LOUDSPEAKER DEVELOPMENTS

ONE of the characteristics of the third International Sound Festival held recently in Paris was the considerable support given to the organization of stereo and other demonstrations by Radiodiffusion-Télévision Française. Foreign radio organizations from Italy, Holland and Switzerland also took part.

"Foreigners" were also well represented among the exhibitors, although in this case the "foreigners" were mainly British. In fact, of the total of forty-three stands, eleven formed a joint British section organized by the Audio Manufacturers Group of B.R.E.M.A. and paid for by the Board of Trade. British equipment was also shown in several cases by its French distributors.

As it happened, almost all the unusual items we noted were in the fields of loudspeakers or amplifiers, and so we are confining this report almost entirely to these two fields.

Mention should however be made of the Frei "Echolette"—a compact device for producing artificial reverberation effects which was shown by Lyrec. This device uses an endless band of magnetic tape in association with three record and two replay heads. These may be used to produce single echos with several delay values lying between about 0.05 and 1 sec. By combining a number of such echos at various levels, artificial reverberation effects may be produced.

ponse of each cell extends within 2dB to 25kc/s—the low-frequency response extends (also within 2dB) to 1kc/s or lower, depending on the total cell area in use and how the cells are loaded acoustically. The intermodulation distortion is claimed to be less than 2% at 5 watts output (for each cell). A square wave reproduced by this loudspeaker bears a considerable resemblance to the original: readers who have seen oscillograms of square waves as reproduced even by high-quality conventional moving-coil loudspeakers will know that this is a remarkable achievement. Each cell has a directional characteristic covering an angle of 30° at 15kc/s (for 6dB down). The fundamental resonance is at 40c/s and the diaphragm can move up to one quarter of an inch. The efficiency is somewhat below that of a conventional moving-coil loudspeaker and the impedance of each cell is 0.35Ω.

A private demonstration was given of a 24-cell full-range free-standing version of this loudspeaker. 30in/sec master tapes (with obviously a very-close microphone recording technique) produced some of the most "immediate" sound your reporter has ever heard. No distortion could be detected, and the bass-drum appeared to be reproduced accurately in that it was partly heard and partly felt.

Another unusual type of loudspeaker was introduced by Philco International. This used "exploded"

LOUDSPEAKERS

Perhaps the most interesting exhibit was the Orthophase loudspeaker shown by Ge-Go. This might be described as a modernized version of the Blatthaller loudspeaker developed in the nineteen twenties. In both cases a number of long magnets placed side by side are used. In the long magnet gaps lie corresponding long driving conductors: adjacent conductor ends are joined so as to form a single zig-zig shaped conductor. This driving conductor is distributed over the diaphragm so that this latter (as in electrostatic speak-

ers) is driven over the whole of its area. The Orthophase loudspeaker uses a foam plastic diaphragm which is flat on one side and ridged on the other. To the ridges are attached the light-metal ribbon driving conductors and these lie between the pole pieces of a set of ferrite magnets (see diagram).

Seventeen magnets and driving ribbons distributed evenly over an area of four by five inches form a single cell unit, and any number of such units may be combined as required. The high-frequency res-

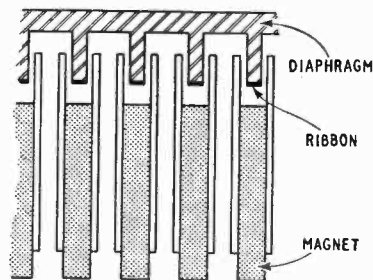
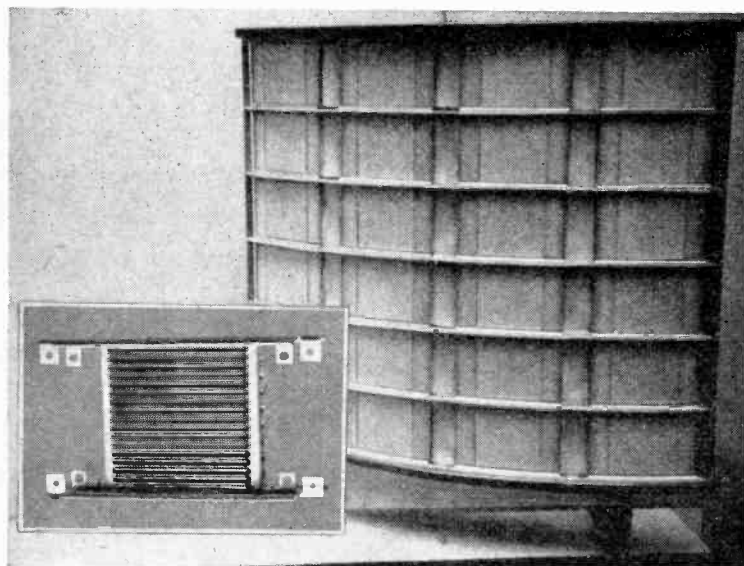

Free standing 24-element Orthophase loudspeaker with (inset) rear view of a single element and (above) diagram showing the construction of one element.

polystyrene as a diaphragm material in order to achieve a high stiffness-to-weight ratio and thus reduce breakup. Although driven normally by a centrally attached voice coil, the diaphragm was unconventionally shaped—convex rather than concave and saucer- rather than cone-shaped. The diaphragm thickness also varied considerably from about 4in at its centre to only about 0.2in at its rim. This rim was suspended by means of special rubberized linen so as to eliminate reflections at the diaphragm edge. The diaphragm was also suspended in various other places, not disclosed. The resonant frequency of this loudspeaker is only about 10c/s in free air: when mounted in its totally enclosed cabinet, the enclosed air stiffness increases this frequency to about 40c/s. The cabinet volume is less than 2 cu. ft. It

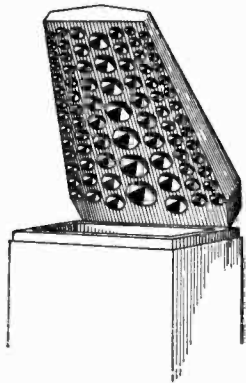

Reflector used in one of the Andre-Radio "Clevox" range of loudspeakers. The conical indentations resonate at different frequencies to correct for deficiencies in the treble response of the loudspeakers.

is claimed that this diaphragm does not break up below about 2000c/s—frequencies above this value are reproduced by a capacitive-fed conventional pressure-driven tweeter.

A high stiffness-to-weight ratio can also be obtained for the diaphragm by making it in sandwich form with the skin material denser and stronger than the filler, as described by D. A. Barlow in our December 1958 issue. The production version of a sandwich cone loudspeaker was shown by Leak. Unlike the prototype first shown at the 1959 Northern Audio Fair, this is associated with a conventional 3-in cone tweeter loudspeaker (crossing over at 1kc/s) rather than an electrostatic unit. Cabinet resonances are, it is claimed, almost completely eliminated by means of a new damping material.

A range of unusual column-shaped loudspeaker systems—the Clevox—was shown by Andre-Radio. Each column contains a number of irregularly positioned flat baffles pro-

Frei artificial reverberation device using an endless loop of magnetic tape (shown by Lyrec).



truding from the interior of its walls. These baffles both increase the effective column length (by forcing the sound to follow a longer path) and, it is claimed, effectively provide a number of pipes of different lengths and thus produce resonant loading over a considerable frequency range. An unusual reflector is also mounted

above the speaker at the top of each of these columns. The surface of each such reflector is indented with a number of conical depressions of different sizes. These depressions resonate at different frequencies to compensate for deficiencies in the high-frequency response of the loudspeaker.

AMPLIFIERS AND PRE-AMPLIFIERS

Two unusual features noted in Gaillard equipment were, in their "Europe" amplifier, a separate ECL82 output stage for feeding an electrostatic loudspeaker with frequencies above 10kc/s and, in their Himalaya amplifier, a voltage-stabilizing circuit (using a 6BQ7A double-triode) for counteracting mains supply variations (these are proportionately greater in France than England).

The Ribet Desjardins "Mozart" stereo radio-gram is unusual in that a single power amplifier is used for frequencies below 300c/s, and two separate power amplifiers for frequencies above 300c/s.

A fully transistorized pre-amplifier and 2×5-watt amplifier formed part of the S.P.E.S. "Monteverdi" stereo sound reproducing system. The amplifier response is claimed to be

within 2dB from 20c/s to 50kc/s with overall feedback of 28dB.

The Innovation demonstration featured a number of American units which, so far as we know, have not yet been exhibited in England. This enabled one to get an idea of some of the more unusual (dare we say exotic) facilities often available in American equipment. For example, a Marantz pre-amplifier could compensate for five different low-frequency and (independently) five different high-frequency record characteristics. In the corresponding power amplifier, the bias of the output stage as well as its d.c. and a.c. balance could be monitored and adjusted. The output valves could be operated either as triodes or in an "ultra-linear" connection and the damping factor of this amplifier could also be varied.

Digital Computer Kit

The Nash and Thompson transistorized kit shown in the photograph enables complete computers to be built directly from schematic diagrams and is suitable for educational or training purposes. The individual sub-unit "brickettes", which are also available separately, include AND gates, OR gates, inverters, delay units, flip-flops and power packs. The majority of the units have emitter-follower outputs so that several units can be connected directly to one output.



Elements of Electronic Circuits

24.—Delay Circuits

By J. M. PETERS, B.Sc. (Eng.), A.M.I.E.E., A.M.Brit.I.R.E.

A DELAY circuit is one which is arranged to allow the passage of a period of time after the application of an input before an output appears. This property enables it to be used in a variety of roles which are principally:—

- (1) To act as a delay or store for pulses in computers so that slow-acting circuits can be permitted to operate.
 - (2) To generate rectangular pulses.
 - (3) To duplicate an existing pulse at a later time.
- Naturally, trigger circuits can be used to produce delays; however the output from these is synthesized and not the original input delayed: in a true delay circuit the input re-appears as the output after the passage of time.

Various forms and modifications of transmission lines are commonly used as delay circuits and an explanation of the properties of transmission lines will assist the reader in following and understanding their operation.

Properties of Transmission Lines

We will assume that L , R , C and G represent the inductance, resistance, capacitance and leakage* of the line per unit length (metre). If the line is uniform and lossless i.e. $\omega L \gg R$ and $\omega C \gg G$

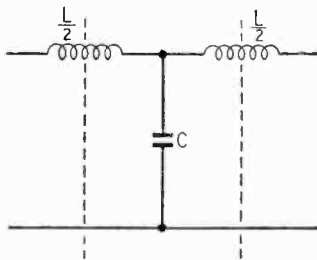

Fig. 1.

then a travelling wave of any shape will move along the line at a uniform velocity without change of shape: if this line is infinite the input impedance is constant and is not affected by the type of waveform applied. Also if the line is of finite length, but properly terminated, the line will appear to the generator to be infinite and the properties of the infinite line will still obtain. An improper termination will cause a reflection and the interaction between incident and reflected waves will create a change in input condition; this effect is used in the generation of rectangular pulses.

Characteristic Impedance.—Still assuming that the line is uniform and lossless, for a travelling wave at any point in the line the ratio (change in voltage)/(change in current) is constant and is equal to

*Leakance, a term meaning shunt conductance, i.e. the reciprocal of the insulation resistance of the line.

$\sqrt{(L/C)}\Omega$ which is known as the “characteristic impedance” of the line (this ratio implies that the voltage and current are in phase with each other). For our hypothetical ideal line the characteristic impedance is a pure resistance denoted by R_0 ; but for the general case of a line which is not loss-free, the expression for characteristic impedance is complex and introduces the terms R and G : this is usually referred to as Z_0 . Another name is the “surge impedance” of the line.

Parallel-Wire Line.—For a balanced line, that is, one formed of two parallel wires, L and C depend on the dimensions of the conductors, their separation and the characteristics of the material between them. If we embed the conductors in a material which has a dielectric constant, κ , different from air this will alter the characteristic impedance, the formula for which can be reduced to:—

$$Z_0 \approx (276/\sqrt{\kappa}) \log_{10}(d/r)\Omega$$

where r = radius of the conductor, d = spacing between conductors and $d \gg r$.

Coaxial Cable.—The coaxial or unbalanced line is made up of a central conductor surrounded by dielectric sheathed by an outer earthed screen. The expression for Z_0 is of similar form and can be reduced to:—

$$Z_0 \approx (138/\sqrt{\kappa}) \log_{10}(r_2/r_1)\Omega$$

where r_2 is the internal radius of the outer conductor and r_1 is the radius of the inner conductor.

Losses.—As the frequency is raised both the resistive (R) and dielectric (G) losses increase. It may seem odd that the resistance of a piece of wire can vary with frequency; but a phenomenon known as the “skin effect” occurs. This, as its name suggests, is the confining of the current to a thin layer at the surface of the conductor. The “inside” of the wire carries no current and can even be removed, leaving a tube.

Transmission Delay

The velocity of propagation along the loss-free line is $1/\sqrt{LC}$ representing a delay of \sqrt{LC} sec/metre. For a uniform open-wire line in free space (strictly, in a vacuum) which does not dissipate energy, L and C are so related that their product is equal to the speed of light $\approx 3 \times 10^8$ metres/sec so that the time delay on an ideal line of this sort is $1/(3 \times 10^8) = 0.003 \mu\text{sec/m}$.

In practice the conductors are usually separated by a dielectric other than air. The general expression for the speed of an electro-magnetic plane wave is:—

$$v = c/\sqrt{\kappa\mu}$$

where c = velocity of light, κ = dielectric constant, μ = magnetic permeability of the dielectric which in practice can be taken as unity.

The time delay is therefore $0.003\sqrt{\kappa}(\mu\text{sec/metre})$.

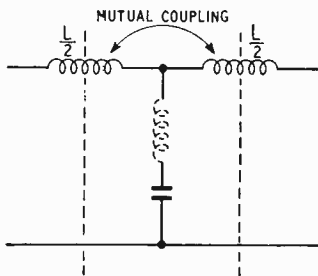

Fig. 2.

A characteristic often quoted by cable manufacturers is "velocity factor"—this is the ratio between transmission speed in free space and in the cable.

Delay Times and Types of Line

For delays as short as $0.005\mu\text{sec}$ it is usual to use coaxial lines where $\kappa \approx 2.5$ (e.g. $0.003\sqrt{2.5} \approx 0.005\mu\text{sec/m}$). Longer delays entail what is usually an unacceptably long coaxial line; however by increasing the length of the inner conductor (by winding it into a spiral) it is possible to obtain delays of the order of $1\mu\text{sec/metre}$. Some special cables use a magnetic material to further slow progress of the wave. The characteristic impedance of these modified lines is usually high and for time delays of this order it is often necessary to resort to artificial lines.

Lumped-Constant Lines.—Artificial lines comprise a number of low-pass filters connected in series. The filter section possesses a delaying characteristic; hence it is possible, by suitable choice of capacitors and inductors, to simulate the true line as the transmission line itself can be regarded as comprising an infinite number of filters in series. One of the difficulties, especially when it is desired to delay steep waveforms, is the preservation of the wave shape. All the frequency components of the pulse (and for an ideal rectangular pulse these extend to infinite frequency) must lie within the filter pass band. In other words the frequency components of the pulse must pass through the section with a constant time delay and amplitude. This is impossible to achieve in practice but a compromise is reached in which the filter possesses amplitude and time delay characteristics independent of frequency over a fairly wide band of frequencies. With a line comprising simple filter sections ("constant k ") (see Fig. 1), it is necessary for the cut-off frequency to be very much higher than the frequencies to be passed, if distortion is to be avoided. If more complex sections with mutual coupling between the coils are resorted to ("M-derived") (Fig. 2), then it is possible to pass, without distortion, frequencies which are a much higher percentage of the cut-off frequency. In other words, the M-derived section possesses a flatter characteristic with a sharper fall at the cut-off point.

Mechanical Lines.—Lumped-constant lines can give long delays, but even these constructions become cumbersome and it is usually necessary to resort to the use of "mechanical", rather than electrical, transmission. Mechanical lines are diverse in form; but three common types are considered here:

Mercury Tubes: The electrical pulse is converted into a supersonic compression wave by means of a quartz or magnetostriction transducer. The

wave is applied to a tube of mercury through which it passes at a relatively low velocity.

$$v = \sqrt{E/\rho}$$

where E is Young's modulus of the medium and ρ = density of the medium.

Another transducer reconverts the acoustic wave to an electro-magnetic wave. It is necessary to maintain the medium at a controlled temperature since the velocity of the supersonic wave varies with temperature. Special precautions are also necessary to prevent unwanted reflections.

Torsion Wire: The mercury tube is long and can be inconvenient. A simpler form of delay line makes use of the transmission of a "twist" applied to a length of wire, which can be coiled up and supported on a compliant suspension without deleterious effects. The "twist" is usually applied by magnetic means.

Quartz Plate: Another form of mechanical line uses a many-sided plate of quartz arranged so that a wave fed in at one side is reflected internally from the other sides in turn until it either returns to the input or reaches an output transducer.

Satellite Tape Recorder

FIVE tape recorders like the one shown in the photograph are in use in the U.S. Army's Courier 1B "delayed-repeater" communications satellite. When in range of the Puerto Rican or Fort Monmouth (New Jersey) ground station, the satellite can either receive and record or replay and transmit 340,000 words in a five-minute period. Four of the tape recorders are used for transmitting and receiving digital data at a rate of 55kilobits per second, and the remaining one for analogue signals from 300 to 50,000c/s (the tape speed is 30in/sec).

As it is hoped that the satellite will remain in orbit for at least a year, a tape was required which could withstand at least 10,000 passes across the heads. The tape selected was "Scotch" Brand No. 199, a heavy-duty instrumentation tape made by the Minnesota Mining and Manufacturing Company. To produce the low wear required, the same binder is used as is normally employed with videotape. The tape must also be capable of withstanding extremes of temperature: this binder showed no deterioration when tested from -40 up to $+250^\circ\text{F}$.

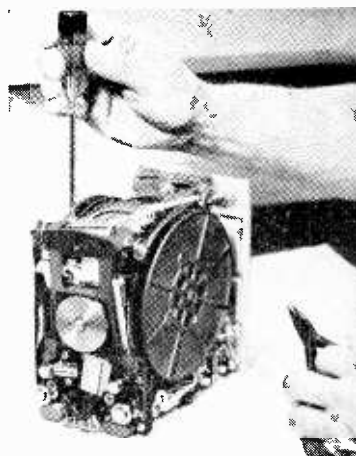

Tape recorder used in the Courier 1B "delayed-repeater" communications satellite.

WORLD OF WIRELESS

German TV Chaos

THE opening date for West Germany's u.h.f. television network, originally planned for January 1st, is again postponed; this time for a further two or three months. This decision was taken by the West German Federal Court, who ruled that the Federal Government is not allowed to set up and operate a television network of its own as, according to the Constitution, all broadcasting activities must be conducted by the Länder Governments.

The thirty u.h.f. transmitters constructed by the German Post Office in readiness for the government network have so far had to confine themselves to test transmissions. It is not yet known whether or not these stations will be used by the Länder. Another problem is what will happen to the private company, *Freies Fernsehen G.m.b.H.*, which was designated sole programme contractor to the government u.h.f. network. The company has a library full of recorded TV programmes and no transmitters to broadcast them.

West German set manufacturers who have been advertising and producing u.h.f. sets for more than six months are facing trouble, too. The uncertainty about the start of the u.h.f. network has made the public reluctant to buy u.h.f.-equipped sets and stocks of old models (without u.h.f.) are mounting despite price cutting.

It is still not known whether the Länder u.h.f. network will operate on a commercial basis (the government u.h.f. plans were for commercial broadcasts) or whether it will follow the pattern set in the v.h.f. bands by local stations which are non-profit-making but have up to 15 minutes of commercial time per day.

Tape Recorder Import Duty

TWO consolidated actions were recently brought by Grundig (Great Britain) against the Commissioners of Customs & Excise to recover part of the 20% *ad valorem* duty charged on tape recorders imported from Germany in 1958 and 1959; their claim being that they should have come under the category of dictating machines and subject to only 10% duty. In a reserved judgment Mr. Justice Barry granted Grundig a declaration that recorders imported between June and November, 1958, were dictating machines liable for only 10% duty and were not musical instruments. He dismissed their claim for a similar declaration on other recorders and found that they were "combined recorders and reproducers" suitable for reproducing music and were liable for 20% duty.

It was stated that on instructions from Grundig, the German makers had removed small resistors from the machines to reduce their frequency response, but similar resistors were installed after the machines arrived in Britain. Plaintiffs had frankly admitted that the sole purpose for the machines being "maimed" in Germany was to attract the lower import duty rate and they had not attempted to conceal what they had done from the Commissioners.

Stockholm Broadcasting Conference

AT the invitation of the Swedish Government, the European VHF/UHF Broadcasting Conference, convened by the International Telecommunication Union, is to be held in Stockholm from May 26th to June 22nd. The delegations, representing the telecommunication administrations of Europe, will have two principal tasks. First, to examine the present situation of v.h.f. sound and television broadcasting in the European Broadcasting Area (which includes North Africa and part of Asia Minor). The Conference will therefore have to consider whether experience has brought to light any serious defects in the 1952 Stockholm Plans and, if so, to decide what remedies might be applied.

The second and, perhaps, most important task will be in the field of u.h.f. television for which no allocations were made at the 1952 Conference.

To undertake the technical preparatory work for the Conference, a meeting of experts organized by the C.C.I.R. was held in Cannes early in March. Four committees were constituted, dealing respectively with propagation, sound broadcasting, television broadcasting and planning methods for Bands IV and V.

The question of planning methods is a more delicate one in Bands IV and V, compared with Bands I and III, because the u.h.f. bands represent an almost continuous region of the spectrum from 470 to 960 Mc/s, which means that second-channel and receiver-oscillator interference have also to be taken into account when assigning frequencies to stations. It is consequently rather doubtful whether the arbitrary methods adopted at earlier conferences can be applied successfully. The European Broadcasting Union has proposed the use of computers; the problem being the large number of variables in each case and the repercussions of any particular assignment on many other channels.

All the European administrations have adopted 8 Mc/s channel spacing and all Continental European administrations have agreed to utilize a 625-line standard for u.h.f. television.

In the field of sound broadcasting, the experts have come to the conclusion that as yet insufficient data exist to take the special requirements of stereophonic broadcasting into account and it is, therefore, probable that the Conference will plan Band II for "mono" only.

Electronics Review

AN ever-increasing proportion of the cost of "military" aircraft is for the electronic equipment installed. Whereas in the *Scimitar* it was 5%, and in the *Sea Vixen* 14%, in the new *NA39* it is 20%. These figures were given by C. I. Orr-Ewing, Civil Lord of the Board of Admiralty, who was guest of honour at the annual luncheon of the Electronic Engineering Association. He also stated that 21% of the cost of a *Leander* frigate was for the electronic content.

The Association has again issued a well-illustrated

annual review, "British Electronics Engineering," which in its 28 pages outlines the various fields for which its members manufacture capital equipment. The British radio and electronics industry as a whole is now producing some £500M worth of equipment a year (increasing at the rate of 10%) and £175M of this total is manufactured by the capital goods division of the industry.

E.E.A. Council.—The new Council of the Electronic Engineering Association consists of the following member firms, whose representatives' names are in parenthesis:—

A.E.I. (V. M. Roberts); Decca Radar (C. H. T. Johnson); E.M.I. Electronics (C. Metcalfe); Elliott Brothers (W. R. Thomas); Ferranti (W. D. H. Gregson, vice-chairman); G.E.C. (Dr. D. N. Truscott, chairman); Kelvin & Hughes (C. G. White); Marconi's W/T (F. S. Mockford); Mullard Equipment (R. R. C. Rankin); Murphy Radio (K. S. Davies); Plessey Co. (P. D. Canning); Pye Telecommunications (J. R. Brinkley); Redifon (A.V.-M. E. B. Addison); and S.T.C. (L. T. Hinton).

A.P.A.E.—The Association of Public Address Engineers is negotiating with the Post Office for the allocation of a frequency for radio microphones which are being marketed by some of its members. At the Association's recent exhibition two of these, one from West Germany and another from Japan, were shown. The new president of the association is J. Maurice, managing director of Lustraphone Ltd.

B.M.E.W.S.—In order to "protect operating personnel from the extremely high r.f. radiated power . . . and to ensure interference-free conditions for the varied electronic equipment" used on the B.M.E.W.S. site at Fylingdales, Yorks, extensive screening is necessary. Belling and Lee announce that they have been engaged to assist in the design and implementation of r.f. shielding and interference suppression.

Via the Moon.—The first England-Australia radio link using the moon as a reflector was made on February 24 by Pye engineers working in co-operation with the staffs manning the radio telescopes at Jodrell Bank and Sydney. A Pye 1-kW double-sideband a.m. transmitter was used to feed the signals from voice-frequency teleprinter equipment into the 250ft paraboloid at Jodrell Bank. At Sydney a new 60ft radiotelescope was used.

VOR/DME.—A plan for the provision of the short-range navigation aids VOR and DME in the European-Mediterranean area has been prepared by an International Civil Aviation Organization regional meeting recently held in Paris. The plan, which will now be submitted to the Air Navigation Commission and the Council of I.C.A.O. for approval, involves over 550 facilities at approximately 380 locations.

Tape Recording.—Over 1,300 tapes were submitted for a competition for 2½-minute tape recordings sponsored by Curry's, the radio and electrical dealers, in a Radio Luxembourg programme.

Receiving Licences.—January's increase in the number of combined TV/sound licences was 72,459, bringing the total to 11,148,463. Domestic sound-only licences totalled 3,532,922 and the number of licensed sets fitted in cars was 464,226.

Training schemes operated by the Ultra group of companies are outlined in the booklet "Guide to Training Schemes" available from the company's head office at Western Avenue, Acton, London, W.3.

Another Jubilee.—The 50th anniversary of the establishment of the British Electrical and Allied Manufacturers' Association this year will be marked by a number of special events, including the issue of a new Electrical Export Directory with a reference section in five languages, including Russian. Reference is made in the 50th annual report of the Association to its two latest sections—"Semiconductor Devices" and "Industrial Electronics." The latter has been established "to provide the means of closer discussions with other associations and help towards the wider examination of general policy questions affecting the industrial electronics industry as a whole."

Higher Technological Education.—The reasons for comparatively fewer students electing to read for technological qualifications in this country than in the U.S.A. and Russia are to be investigated by the University of Oxford's Department of Education led by its director, A. D. C. Peterson. The research, which will continue for two years, has been made possible by a grant of £2,500 from the Capitol Radio Engineering Institute, of Washington, through its International Division, C.R.E.I. (London).

Dip.Tech. and M.C.T.—A revised edition of the booklet giving details of the two awards (Dip.Tech. and Membership of the College of Technologists) conferred by the National Council for Technological Awards, is now available from the Council at 9, Cavendish Square, London, W.1.

Technical Authorship.—The results of the first examination in technical authorship conducted by the City and Guilds of London Institute will be discussed by W. Hazel, of the Ministry of Aviation, at a meeting of the Technical Publications Association at 7.0 on April 20th at Monotype House, Fetter Lane, London, E.C.4. The meeting is not confined to members of the Association.

Audio Centre.—On May 17th a Centre of Sound for both industrial and amateur "devotees of the science of sound" will open at 12, Archer Street, London, W.1. It is sponsored by the newly formed Audio Industries Club Ltd. in association with the British Recording Club. The centre will incorporate an exhibition of sound equipment, a demonstration theatre for both sound and vision, an information bureau and a restaurant.

Maurice Child, the well-known radio amateur, has presented to the Radio Society of Great Britain a collection of antique radio equipment. The collection of 26 items is almost entirely of pre-1914/18 vintage. Mr. Child is a vice-president of the Society and was for many years principal of the London Telegraph Training College.

Demonstrations of loudspeakers (both domestic and monitoring) and professional recording equipment are being given by Lockwood and Co. in collaboration with other manufacturers at the I.B.C. Recording Studios, 35, Portland Place, London, W.1, on April 6th and 7th from 6 to 9.30 p.m. and on April 8th and 9th from 9.30 a.m. to 9.30 p.m.

Westward TV.—Full-power trade tests have been radiated since March 20th from both the I.T.A. transmitters which will serve S.W. England. They are transmitted daily (except Sundays) from 10 a.m. to 9 p.m. The programme contractors for both transmitters, Stockland Hill, Devon (Channel 9) and Caradon Hill, Cornwall (Channel 12), are Westward Television who plan to start their service on April 29th.

"Applications of Frequency-Sweep Oscillators."—Unfortunately, due to pressure on space, the concluding part of R. Brown's article has had to be held over until our next issue.

News from Industry

Marconi's.—The 63rd annual report of Marconi's W/T Company and its subsidiaries shows a group profit for 1960 of £57,892 compared with £411,470 for the previous year. This decline has resulted from the writing off of a loss of £670,000 incurred during the year by Marconi Italiana S.p.A. The company became a wholly owned subsidiary in September 1959, and Lord Nelson of Stafford in his reference to this at the Marconi annual general meeting said that investigation had disclosed that inadequate provision had been made for losses incurred by the Italian company prior to 1960. The 61st annual report of the Marconi International Marine Communication Company shows a net profit of £304,276 against £264,624 for 1959.

Relay Exchanges Ltd. and its subsidiary companies announced a group trading profit for 1960 of £3,949,892, almost £600,000 above the 1959 figure. After allowing for taxation and £2.75M for depreciation the net group profit was just over £1M.

Radio Rentals have changed the name of their set-manufacturing subsidiary from Mains Radio Gramophones Ltd. to Baird Television Ltd. It will be recalled that they recently acquired the trade name from Hartley Baird Ltd. The chairman's annual report records a record trading profit of £5.95M which is some £850,000 above the previous year. After charging £3.44M for depreciation and allowing for taxation the net group profit showed an increase of nearly £500,000.

T.C.C.—A trading profit of £701,737 for 1960, compared with £770,679 for the previous year, is announced by the Telegraph Condenser Company.

Packaged television stations, costing under £10,000, are being marketed by E.M.I. Electronics Ltd. to provide a low-cost, uncomplicated television system for mass education and instruction by television. In a region with flat terrain, good reception should be obtained within 15 miles radius of the transmitter. A number of receivers is supplied with each transmitter.

Power System Computers Ltd., of Team Valley, Gateshead-on-Tyne, 11, have undertaken to manufacture the analogue computers developed in the Department of Electrical Engineering at Sunderland Technical College.

EMIFAIR—an exhibition of medical, musical and scientific developments of the E.M.I. family of companies—will shortly commence a tour of the country. The exhibition contains 16 stands. The major emphasis is on Ardent hearing aid equipment, but included among the other exhibits are records and record reproducers, and tape recorders for sound reproduction and dictation.

Anglo-Czechoslovak trade agreement for 1961 provides for about £5.6M worth of U.K. goods to go to Czechoslovakia and about £8M worth in the reverse direction. The quota includes Czech valves and transistors to the value £60,000 (not more than a fifth of which may be transistors) and gramophone records and tapes to the value of £20,000. The quota of U.K. exports under the agreement lists £50,000 worth of electronic and communication equipment including sound and television receivers.

Anglo-French co-operation in the field of communication earth satellites is provided for in a joint study to be undertaken by the Hawker Siddeley group and SEREB (Société pour l'Etude et la Réalisation d'Engins Ballistiques) of Paris. SEREB was set up two years ago by the French government to act as systems managers for all ballistic weapon development to be undertaken in France or in association with other countries.

Computer appreciation courses for executives are conducted from time to time by Leo Computers Ltd. The week's course "providing a sound introduction to data processing in general" is non-residential and costs 25 gn. Particulars of the next series of courses, which will be held on April 10th to 14th, July 10th to 14th and September 11th to 15th, are obtainable from Leo Computers Ltd., 151A-159A Queensway, London, W.2.

Rank Precision Industries have been granted exclusive selling rights in the U.K. and many overseas territories for the Dage range of closed-circuit television equipment manufactured by Thompson Ramo Wooldridge, of Michigan City, Indiana. The Dage range of cameras includes one of only 7¼" long and weighing only 4lb. It is "completely transistorised" and is available with a three-lens turret.

B & K Laboratories, of 4 Tilney Street, London, W.1, are to market in this country two new spectrum analysers developed by the Polarad Electronics Corp., of New York. One (type WSA) covers 10-40,000Mc/s in 20 bands and the other (type DA70) 50-100Gc/s in three bands.

Vicsteels Ltd., of Craven House, 16, Northumberland Avenue, London, W.C.2, have been appointed U.K. agents of Lumalampan AB, of Stockholm, manufacturers of tungsten and molybdenum wire and the Luma wire cutting, stripping and twisting machine.

Ultra Electronics are to supply 40 sets of their UA60 intercom. equipment for the Westland P.531 aircraft being supplied to the Army Air Corps. The value of the contract is approximately £21,000.

W.S. Electronics Ltd., a member of the K.G. (Holdings) Group, has been awarded a contract for a further 300 u.h.f. airborne emergency transmitter-receivers, (Type D103) for the Royal Air Force.

Livingston Laboratories Ltd. are moving to new premises at 31, Camden Road, London, N.W.1 (Tel.: Gulliver 8501) on April 4th.

EXPORTS

Rhodesian police are to be equipped with Cossor packset transmitter-receivers. These v.h.f. sets, which weigh only 5 lb, will be used for ground and ground-to-air communications.

Signal generators to the value of approximately \$160,000 have been ordered from Marconi Instruments for the Royal Canadian Air Force. The instruments, which cover the 10-470Mc/s frequency range, are amplitude modulated.

A Continental tour to promote the next International Instruments, Electronics and Automation Exhibition, to be held in London in May, 1962, is being undertaken by the organizing committee. They have already visited several cities and from April to June will visit Milan, Brussels, Amsterdam, Paris, Stockholm and Frankfurt.

Sweden has placed a further contract with Marconi's (following substantial orders in 1959) for the supply of "secret electronic equipment" for her air defence system. The contract is valued at over £1.7M.

Personalities

Lord Nelson of Stafford, LL.D., chairman of the English Electric group of companies, has been elected to honorary membership of the Institution of Electrical Engineers "in recognition of his outstanding contribution to the development of electrical science and engineering, and for his many services to The Institution." Lord Nelson, who was a post-graduate student with the Brush Electrical Company, Loughborough, became their chief outside engineer at the age of 22. He later joined the British Westinghouse Company (which became Metropolitan-Vickers). His association with the English Electric Company started in 1930 when he was appointed managing director. Lord Nelson was created a Baronet in 1959 and raised to the peerage in 1960.

Julius A. Stratton, Sc.D., LL.D., president of the Massachusetts Institute of Technology, is the 39th recipient of the Faraday Medal of the I.E.E., which he is awarded for "his notable contributions in the fields of technological education and research in radio communication." Dr. Stratton, who will be 60 in May, has been on the staff of M.I.T. since 1924 when he joined as a research associate. He was in the radiation laboratory from 1940 until 1945 when he became director of the research laboratory (electronics). He remained in that post until his appointment as president in 1959. Dr. Stratton has made "an outstanding contribution to the theory of transmission line, waveguide and antenna systems in relation to the wartime development of centimetre-wave radar."

D. N. Truscott, O.B.E., A.C.G.I., D.I.C., B.Sc., Ph.D., Sc.D., general manager of the electronics division of the G.E.C., which he joined ten years ago, has been elected chairman of the Electronic Engineering Association in succession to **L. T. Hinton** (Standard Telephones and Cables). Dr. Truscott was for four years in the engineering department of Murphy Radio which he left in 1939 to join the Ministry of Aircraft Production where he was an assistant director from 1944 to 1945. He then spent six years in the Ministry of Supply as an assistant secretary.

N. McAdam, B.Sc., has been appointed chief engineer of the industrial valves and cathode-ray tubes department of the A.E.I. Radio and Electronic Components Division. After spending five years with A. Reyrolle and Company as a student apprentice he graduated in electrical engineering in 1933. In 1934 he joined Mullards and a year later went to the Edison Swan Electric Company as a junior development engineer. In 1947

he went to the company's valve factory at Sunderland as chief factory engineer. He became divisional chief inspector for the Edison Swan group of factories in 1955.

Cifford Metcalfe, C.B.E., will, at his own request, relinquish the managing directorship of E.M.I. Electronics Ltd., on July 1st. He will remain a full-time director of Electric & Musical Industries Ltd., and will devote his main attention to initiating technical and development policy for new products. He will be succeeded as managing director of E.M.I. Electronics Ltd. by **Percy A. Allaway** who has been his deputy since 1957. Mr. Metcalfe spent his early years with Bristol Aeroplane Company on engine design. He joined the Gramophone Company in 1930 as a mechanical designer and was appointed a director of E.M.I. Engineering Development Ltd. in 1946. Mr. Allaway also joined the Gramophone Company in 1930. He spent the war years designing equipment for radar and similar electronic devices. He was appointed general manager of E.M.I. Engineering Development Ltd. in 1953, and works director in 1956.

Charles Bovill, A.M.I.E.E., M.Brit.I.R.E., A.F.R.Ae.S., has joined Multisignals Ltd. as executive engineer. He had previously been with the Decca group since 1946, first with the Navigator Company and since 1954 with Decca Radar as overseas technical representative working mainly in France. Trained at the University of Grenoble, France, and the Regent Street Polytechnic, he joined the development department of the Gramophone Company in 1933. From 1936 to 1937 he was with the Air Ministry, and in 1938 joined the air division of Marconi's, later becoming liaison engineer with R.A.F. Bomber and Coastal Commands. Mr. Bovill was commissioned in the R.A.F.V.R. in 1942 and was appointed officer in charge of the Air Operational Research Group of the Inter-Services Research Bureau.

D. Edmundson, general manager of the Rugby works of A.E.I. since January last year, is appointed manufacturing manager, A.E.I. Electronic Apparatus Division in succession to the late E. T. W. Barnes. Mr. Edmundson served an engineering apprenticeship with B.T.H. In 1940 he was appointed head of the electrical laboratory, and in 1946 test engineer, Rugby works, eventually becoming superintendent, test department. **G. P. Thompson**, who becomes manager of the Rugby works of A.E.I., joined B.T.H., Rugby, as a student apprentice in 1930.



Dr. D. N. Truscott



N. McAdam



P. A. Allaway



C. Bovill

E. A. W. Spreadbury, M.Brit.I.R.E., associate editor of the *Wireless & Electrical Trader*, has been elected chairman of the Radio Trades Examination Board for a second term of office. He has been associated with the work of the Board since its inception in 1944 and was for many years an examiner in both sound radio and television servicing. He joined the laboratory staff of *Wireless Trader* in 1937 where he was responsible for the preparation of the service sheets issued by the journal.

Three appointments to the directorate are announced by the Solartron group. **R. Catherall**, B.Sc., who joined Solartron Laboratory Instruments as a development engineer in 1952 and since 1957 has been a director of Solartron Research and Development, joins the group board as director of research and development. After graduating at Manchester University he joined Rotol Ltd. where he was concerned with the development of electronic equipment for vibration measurements in aircraft propellers. In 1948 he went to S. Smith and Sons on automatic pilot design. Soon after joining Solartron



R. Catherall

H. D. Binyon

in 1952 he became responsible for the development of their transfer function analyser. **H. D. Binyon** has joined the group board as director of product sales. He joined Solartron Laboratory Instruments in 1952. After coming down from Magdalen College in 1940 he joined the R.A.F. Signals Branch and in 1947 went to the Cavendish Laboratory, Cambridge, for two years. **L. Malec**, M.B.E., who joined the group two years ago as managing director of Solartron Radar Simulators is appointed director of systems sales to the group. After war service in the R.A.F. he joined British European Airways. From 1948 to 1959 he was with Air Trainers Ltd., of which he subsequently became managing director.

J. Reekie, B.Sc., Ph.D., M.I.E.E., who joined Semiconductors Ltd., the Plessey-Philco company, in 1957 as chief engineer and subsequently became executive director and general manager, is being detached for special duties by the board of the Plessey company, and will shortly be visiting a number of overseas territories on behalf of the company. **G. W. Pratt** has been seconded by the Philco Corporation of America to act as general manager of Semiconductors Ltd.

J. W. Haig-Ferguson, M.A., A.M.I.E.E., has recently been appointed managing director of R. & J. Beck Ltd., one of the Griffin & George group of companies. Mr. Haig-Ferguson, who was born in 1923 and is a graduate of Queen's College, Cambridge, was in R.E.M.E. in the latter part of the war. He was until recently divisional director (electronics) of Bruce Peebles & Co. Ltd., Edinburgh.

K. A. Robinson, A.M.Brit.I.R.E., who joined Lancashire Dynamo Electronic Products in 1948 as chief development engineer, has been appointed to the board of the company, which is a member of the Metal Industries group. Mr. Robinson, who is 34, was appointed chief engineer in 1959. Before joining the company he was concerned with the development of industrial electronic equipment with the English Electric Company.

A. S. D. Barrett, B.Sc.(Eng.), M.I.Mech.E., M.I.Chem.E., has been appointed consultant to Research and Control Instruments Ltd., and has joined the board of directors. Prior to setting up in private practice as an industrial consultant at the beginning of this year Mr. Barrett was technical director of Edwards High Vacuum Ltd. He is a vice-chairman of the Scientific Instrument Research Association and secretary of the International Organisation for Vacuum Science and Technology.

The board of Livingston Laboratories has been enlarged and now includes **F. Livingston Hogg** as chairman and joint managing director, **D. C. Rennie** (joint managing director), **M. R. Hogg**, **H. Sellers**, **S. W. Urry** and **F. R. G. Webb**.

OUR AUTHORS

Richard C. Foss, B.Sc., Grad.I.E.E., joint author of the article on multivibrator design in this issue, joined E.M.I. Electronics on leaving school in 1952. During four years' training he spent two years working on digital computers. He studied at Southall Technical College and won an I.E.E. prize and a Technical State Scholarship, going to King's College, Newcastle-upon-Tyne, in the University of Durham, where in 1959 he graduated with first class honours in electronics. He is now carrying on research on second-harmonic magnetic modulators and some applications using ferrites, having been awarded the Oliver Lodge Scholarship of the I.E.E. (made honorary by the financial support of E.M.I. Electronics). His co-author, **Malcolm F. Sizmur**, B.Sc., also joined E.M.I. Electronics in 1952. He took his H.N.C. at Slough Technical College and won an I.E.E. prize and Technical State Scholarship. He spent two years in the digital computer division of the company and he too went to King's College, Newcastle-upon-Tyne, where he obtained a general degree in electrical engineering.

E. Jeffery, A.M.I.E.E., the first part of whose article on a low-cost stereo amplifier appears in this issue, has been an engineering superintendent at the Bracknell Division of the Sperry Gyroscope Co. since 1956. He entered the Post Office Engineering Dept. in 1936 and during the war was an officer instructor at the Army Radio School at Petersham. At the end of the war he took a regular commission in R.E.M.E. and was for some years Major Chief Instructor (first in telecommunications and later in radar and control equipment) at the R.E.M.E. Training Centre, Arborfield, Berks. He was at one time in charge of the electronics branch of R.E.M.E. Base Workshops, Singapore. After resigning from R.E.M.E. he was technical executive to Modern Telephones Ltd. until joining Sperry. His present article derives from his personal interests and is not related to his work at Sperry.

Arthur C. Gee, who reviews on page 231 the growing interest among amateurs in the use of teleprinters, is a doctor by profession and, "believing that hobbies are essential for the well-being of mankind," has been a radio amateur for many years. Dr. Gee is chairman of the Radio Amateur Emergency Network committee of the R.S.G.B.

Fifty Years' Research in

RADIO WAVE PROPAGATION

By R. L. SMITH-ROSE,* C.B.E., D.Sc., F.C.G.I., F.I.R.E., M.I.E.E.

WHILE in 1911 great achievements had been attained in the practical developments of wireless telegraphy, there was little understanding of the manner in which the electromagnetic or radio waves involved travelled over the earth's surface; and particularly as to how it came about that these waves, which normally travel in straight lines, could bend round the spherical earth.

This was brought out very clearly in a lecture given by G. Marconi before the Royal Institution on 2nd June, 1911. The following extract is taken from the report of this lecture in the July, 1911, issue of the *Marconigraph*, a journal which was incorporated in the *Wireless World* less than two years later (April, 1913).

"Although we have—or believe we have—all the data necessary for the satisfactory production and reception of electric waves, we are yet far from possessing any very exact knowledge concerning the conditions governing the transmission of these waves through space—especially over what may be termed long distances. Although it is now easy to design, construct and operate stations capable of satisfactory commercial working over distances up to 2,500 miles, no clear explanation has yet been given of many absolutely authenticated facts concerning these waves."

Later on in the same lecture, Marconi said:

"Although the mathematical theory of electric wave propagation through space was worked out by Clerk Maxwell more than fifty years ago, and notwithstanding all the experimental evidence obtained in laboratories concerning these waves, yet so far we understand but incompletely the true fundamental principles concerning the manner of propagation of the waves on which wireless telegraph transmission is based."

Such statements, based on experimental measurements, aroused great interest since it had hitherto been considered that the electromagnetic waves involved travelled over the surface of the earth. The attenuation of the waves was less over sea than over land owing to the much greater electrical conductivity of salt water. W. Duddell and J. E. Taylor had shown in 1905 that for distances up to about 60 miles, the signal strength of radio waves was nearly inversely proportional to the distance between transmitter and receiver. But for distances beyond 100 or 200 miles, it was found by other investigators that signal strength decreased more rapidly; and L. W. Austin and L. Cohen obtained better agreement between calculated and measured signal strength by adding an exponential factor, involving both distance and wavelength, to the inverse distance relationship. Although this "Austin-Cohen formula" was used for several years by radio design engineers as a convenient practical guide, it was soon found to have serious limitations. The most important of

these was the discovery that at distances greater than a few hundred miles, the strength of received signals varied from day to night: for the wavelengths and conditions then in use, the signal strength was usually greater, but more variable, by night than by day.

The first systematic discussion of these phenomena is also recorded in the issues of the *Marconigraph* for September to November, 1912, particularly by Drs. W. H. Eccles and J. A. Fleming, both of whom were closely associated with Marconi in his pioneer development of wireless communication. What was termed "The Effect of Daylight upon Radiotelegraphic Waves" became an active subject of discussion; and H. J. Round was the leading Marconi engineer who, with K. W. Tremellen, made many systematic measurements of the changes in signal strength over short and long distances due to the passage of the sunrise and sunset boundaries across the path. (See Fig. 1.)

At the 1912 Dundee meeting of the British Association Professor Fleming opened a discussion on the subject of "Unsolved Problems of Wireless Telegraphy," which was published in the *Marconigraph* for October, 1912. From the theoretical contributions made by Professors J. W. Nicholson and A. Somerfield, it became clear that diffraction alone could not account for the transmission of waves round the surface of the earth to the extent that had

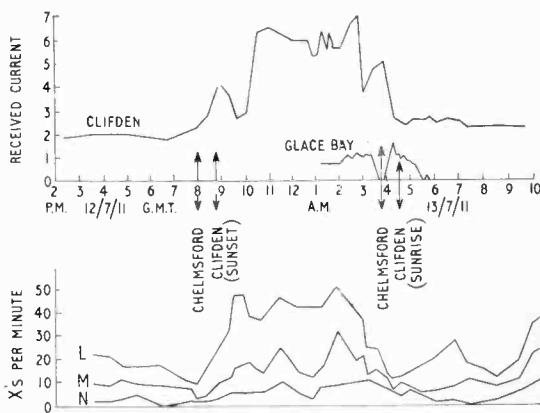

Fig. 1. Measurements of strength of signals and atmospheric noise made at Chelmsford in July 1911. (a) The upper curves relate to the reception of signals from Clifden and Glace Bay. (b) Observations of the number of atmospherics per minute which produced peak voltages of 3(L), 6(M) and 12(N) respectively. Note the effect of day and night conditions on both signals and atmospherics.

* President of the International Scientific Radio Union (U.R.S.I.).

already been demonstrated. Having regard to the long waves used, however, 6 km or more, and the difference in conductivity between land and sea, it was still necessary to consider the ground wave propagation phenomena up to moderate distances.

It was in the course of this discussion that the effect of sunlight on the propagation of radio waves was emphasized by Dr. Eccles; and he described in some detail his study of the possibilities of an ionized layer in the atmosphere acting as a reflector of radio waves as first suggested by Oliver Heaviside in 1900. With a further contribution from Professor A. E. Kennelly at the British Association discussion, the foundations were laid of an understanding of the characteristics of an ionospheric shell surrounding the earth and which, subject to variations in time and place due to the influence of solar radiation, could reflect upgoing radio waves back towards the earth's surface.

International Collaboration

It was clear from this meeting (in 1912) that progress in investigating the complex phenomena involved could best be achieved by forming a committee or similar body comprising both theoretical and practical workers in the subject. It is therefore significant that in the following year a meeting was held in Brussels to discuss the formation of an international committee to organize and conduct scientific experiments in wireless telegraphy. A reunion was held in Brussels in April, 1914, at which a programme of scientific measurements was drawn up and discussed in some detail. This included observations of the variations in signal strength received in different directions and at various distances from the transmitter; and also simultaneous measurements of the strength of atmospheric disturbances in different places.

This body became the International Scientific Radio Union (U.R.S.I.), which held its first meeting in Brussels in 1922, and its XIIIth General Assembly† in London in September, 1960. During its nearly forty years of existence, the work of U.R.S.I. has covered a range of scientific subjects, such as standards of radio measurements and their application to wave propagation and radio noise, for the study of which on a world-wide scale, international co-operation is not only a great advantage, but indeed a necessity. In addition to pursuing scientific research on radio matters, U.R.S.I. has, for the past thirty years or more, collaborated with the International Radio Consultative Committee (C.C.I.R.) on many problems of mutual interest, particularly those concerned with the design and operation of long-distance communication circuits. It is natural to find that this co-operation is actively continuing in connection with the more recent problems of radio astronomy and communication to and from vehicles in space.

The Ionosphere and Round-the-world Transmission

It was not until 1925 that the first experiments which demonstrated the existence of the Kennelly-Heaviside layer were made by Sir Edward Appleton and his co-workers using the Bournemouth trans-

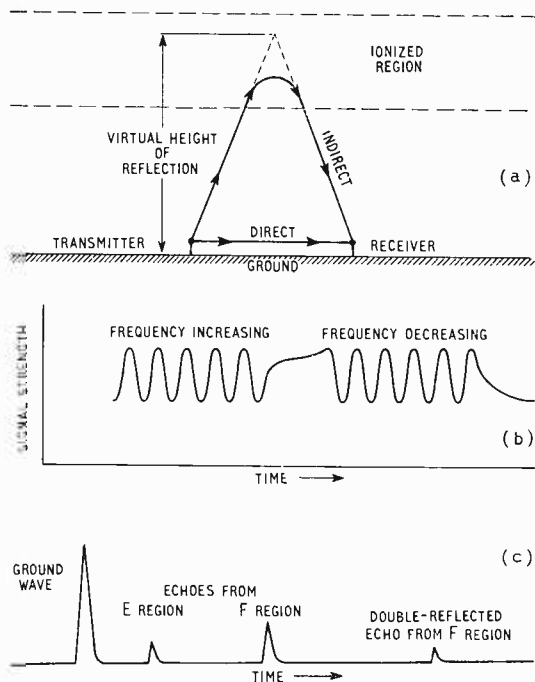

Fig. 2. (a) Paths of direct and indirect waves from transmitter to receiver; and the measured—or virtual-height of reflection of the indirect wave. (b) Interference fringes in received signal due to ground and ionospheric waves, as the frequency of the transmitter is varied over a small range. The ratio of the number of signal maxima to the change of frequency gives the difference in time of arrival of the two signals, and so the height of reflection of the indirect wave. (c) Echoes of transmitted pulses after reflection from the lower (E) and upper (F) ionized regions; and also of an echo of a pulse which has been twice reflected from F with an intermediate reflection at the ground.

mitter of the B.B.C. By changing the frequency of this station, the strength of the received signal was found to vary, indicating an interference pattern such as would be produced by two sets of arriving waves, one travelling along the ground and another coming down after reflection at the ionized layer. (See Fig. 2 (a) and (b).) Confirmatory evidence was found by comparing the signal variations obtained when receiving on a loop and vertical aerial. An alternative method was used by R. L. Smith-Rose and R. H. Barfield, who compared the strength of signal from a transmitting station received simultaneously on a loop and vertical aerial. All these experiments indicated that the radio waves used—about 300m in wavelength—were reflected from an ionized layer at a height of about 100 km. Almost concurrently with this work G. Breit and M. A. Tuve used a pulse technique to measure directly the time interval between the arrival of the pulses travelling along the ground and those which arrived later after travelling up to the ionized layer and down to the receiving station. (See Fig. 2 (c).) A year or two later, by using shorter wavelengths, Appleton and his co-workers showed that at certain times the radio waves could penetrate the first reflecting (or E) region and be reflected from an upper region, termed F, at a height of some 400 or 500 km.

† A brief account of this meeting was given in *Wireless World*, January 1961, p. 10.

These pioneer experiments and discoveries provided, first the complete explanation of the manner in which radio waves can travel right round the earth by successive reflections between the earth and the upper atmosphere; and, secondly, the basis of the subsequent exploration of the physical characteristics of our upper atmosphere which has been in progress for the past thirty years or more. Ionospheric observatories have come into operation for measuring the height and density of ionization of the various reflecting regions, and the manner in which these change from day to night and from summer to winter. The installation of such observatories has gradually spread throughout the world, to over 250 which were in operation on a regular and systematic basis during the International Geophysical Year of 1957-58.

As a result of the international collaboration obtained under the auspices of U.R.S.I. observations made in different parts of the world are freely exchanged, so that national laboratories can prepare charts showing the state of ionization in the upper atmosphere all over the world. Based on data accumulated in this way, over one or more solar cycles of 11 years duration, accurate forecasts can now be made of the ionospheric conditions to be expected up to six months in advance.

Concurrently with this observatory work on conditions at vertical incidence, continuous studies have been made on the transmission of radio waves over oblique incidence paths at distances from a few hundred up to several thousand miles between sending and receiving stations. In this way, a detailed and fairly accurate knowledge has become available for use in the design and operation of long-distance radio communication services throughout the world. The frequencies or wavelengths to be used for such services can be selected in advance according to the time and geographical location of operation, and systematic planning can take place to deal with the diurnal fluctuations in ionospheric conditions as well as with the longer-term variations which follow the solar cycle.

Radar Technique and Back-scatter

It is well known that the use of pulse transmission and receiving technique formed the basis of the development of radar for detecting and locating ships, aircraft and geographical features. It seemed only just, therefore, that research workers concerned with the exploration of the ionosphere should take advantage of advanced and powerful radar techniques for their continued investigations. Following earlier work by T. L. Eckersley on the scattering—as distinct from reflection—of radio waves from ionospheric clouds or regions, E. D. R. Shearman used a high-power radar transmitter to direct a beam of waves horizontally. The waves after reflection from the ionosphere reached the earth's surface at some one or two thousand miles from the transmitter. Some of the energy of the waves was scattered backwards, and after a second reflection at the ionosphere was detected at a receiver alongside or incorporated with the transmitter. From a measurement of the time taken for the pulses of radio waves to travel to and from the sending station, the path of the waves was determined. Furthermore observations made on various frequencies soon showed the characteristics of the ionosphere at the distant

reflecting region. By suitably rotating the aerial system, the beam of waves was made to scan the horizon, and in this way the conditions in the ionosphere all round the observing station could be explored at ranges up to 7,000 miles or so. This technique has proved to be a powerful tool not only for the scientist investigating the ionosphere all round him, but it also enables the radio operator of a long-distance circuit to determine from time to time the best and most suitable frequencies to use in the prevailing circumstances.

Propagation at V.H.F.

In general, radio communication services which make use of ionospheric propagation are confined to frequencies below 30 Mc/s (wavelengths above 10 metres): although it has long been known that under appropriate conditions the density of ionization in the ionosphere is at times sufficient to support the transmission of radio waves within the band 30 to 50 Mc/s. But experience has shown that this type of transmission is comparatively rare and inefficient with normal transmitter powers and receiver sensitivities. To obtain anything approaching a regular service, it is necessary to use the scattering of the waves at the ionosphere which, on account of the weakness of the resulting signals, entails the use of very high power and concentrated beams of radiation. This technique is, however, used in certain "ionospheric scatter" services where the utmost reliability is necessary at all times, irrespective of economy and efficiency.

The main use of the v.h.f. band between 30 and 300 Mc/s (wavelengths 1 to 10 m) is, however, for the localized services involved in broadcasting, television, police and private mobile services, and certain types of beacon and navigational aids mainly perhaps, for aircraft services. These services as used today, are based on the knowledge obtained in research on the propagation of such waves over the past thirty years or so. The subject here is broadly divisible into two parts. First, a study of the electrical characteristics and the physical features of the earth's surface, which mainly determine the transmission of the waves to short distances broadly within the horizon as seen from the sending aerial. Secondly, and particularly at the longer distances beyond the horizon, the strength of the waves arriving at the receiver may be affected to a varying extent by the bending of the waves due to the refractive index gradient in the atmosphere. This refractive index gradient is determined by the temperature, pressure, and more especially, the humidity of the atmosphere, and so the extent to which the waves are bent is very dependent on the weather conditions prevailing over the transmission path.

But considering the shorter-range phenomena first, in order to extend the horizon and so the service of a transmitting station, it is usual to elevate the aerial of the latter as much as possible. It then becomes clear that there are two paths by which the waves can travel towards the receiver. One of these is directly through the air from transmitting to receiving aerial: while the other path involves reflection from the ground, the inverse of reflection from the upper atmosphere. The resulting signal at the receiver is the combination of these two sets of waves, which are usually out-of-phase in practice, and result in the signal strength being inversely propor-

tional to the square of the distance between sending and receiving stations. There are, of course, wide variations in practice from this simple law, mainly due to the effect of obstacles such as hills and buildings in the path of the ground reflected waves.

Next, as already suggested, the direct waves which travel through the air may be subject to bending which may result in their being propagated appreciably beyond the horizon. As a result the "service area" of such a transmitting station is increased beyond the limits of the optical horizon, albeit the extended range is variable and dependent upon the prevailing atmospheric conditions. For practical purposes, in such cases as broadcasting and television services, measurements are made over long periods of time and in various parts of the world to obtain sufficient data to express the results on a statistical basis. An example of the application of this type of study is shown in Fig. 3 which is reproduced from a recommendation of the C.C.I.R. in 1959, setting out the field strengths likely to be received at various distances beyond the horizon for typical proportions of the time of observation. Such information is of direct importance to designers of broadcasting services, and assists them to determine the minimum separation in distance necessary between stations operating in the same frequency channel to secure comparative freedom from any specified degree of mutual interference.

Future Research in Radio Wave Propagation

A general view of the trend of future scientific research in this subject of radio wave propagation can be obtained from the conclusions and recommendations of the various Commissions of U.R.S.I. concerned with this subject. In the first place interest in the propagation of waves through the lower atmosphere is not confined to those concerned with communications. As Commission I indicated, the measurement of standards of frequency and time has become so precise that it is very important to know what changes in phase of both low and very low frequency waves occur over various transmission paths. Furthermore, since both light and radio waves are used in geodetic surveying, it is important to standardize the formulæ used for calculating the re-

fractive index of the air at the working frequencies.

Commission II, dealing with propagation through the troposphere, pointed out that, while further quantitative studies were required to elucidate the statistical facts of propagation beyond the horizon, it was also important to investigate the fine structure of irregularities in the atmosphere. The latter become of increasing importance in connection with the absorption and scattering in the atmosphere at centimetre and millimetre wavelengths. Also, since many of the frequencies likely to be used in space research are susceptible to tropospheric influences, the importance of the effects of these should be examined.

With regard to the propagation of waves through the ionosphere, a subject concern to Commission III, the great co-operative work carried out during the International Geophysical Year (1957-58) has been described in previous publications. § At last year's General Assembly of U.R.S.I. it was noted that several scientific unions, including the International Committee on Geophysics, were organizing a Sunspot Minimum Programme to be conducted during 1964-65 as a companion enterprise to the I.G.Y. which, as is well known, took place during a period of maximum solar activity. The results of this international effort should do much to elucidate some of the outstanding features in our knowledge of the ionosphere, which by 1965 will have been the subject of study by radio scientists for over forty years. By this date also, it may be anticipated that the use of rockets and artificial earth satellites will also have appreciably added to our knowledge of the upper reaches of the ionosphere, which it has so far been difficult to explore by radio waves sent up from ground stations.

Fifty years ago, Marconi engineers and others were recording the number of atmospherics—or X's as they were then termed—which produced a certain voltage across the receiver terminals (see Fig. 1). This study of "Radio Noise of Terrestrial Origin"—to use the present title of Commission IV of U.R.S.I.—has continued ever since on a continually increasing scale all over the world. The number and variety of the various types of noise which produce an audible or detectable response on modern sensitive receivers is now so great that it was decided at the recent General Assembly of U.R.S.I. to draw up an agreed terminology of the subject. Terrestrial Noise comprises those natural electromagnetic disturbances which originate in the earth's atmosphere, and there appear to be four recognizable classes of such noise:

(i) Atmospheric noise which originates in natural electrical discharges below the ionosphere, and which travels to the receiver by the normal paths of propagation between the earth and the lower boundary of the ionosphere.

(ii) Ionospheric noise which originates in the ionosphere and is usually associated with magnetic disturbances.

(iii) Whistlers which are a form of terrestrial noise, originating in electrical discharges in the lower atmosphere, and which are propagated through the ionosphere along dispersive paths. The whistler type of noise when heard at a receiver is characterized by one or more components of the nature of gliding tones, which descend in frequency through the audible range in a period ranging from a fraction of a second to several seconds.

§ See, for example, *Wireless World*, February 1960, pp. 52-58.

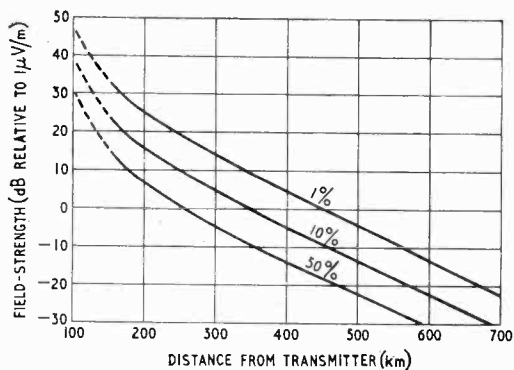

Fig. 3. Frequency range: 40 to 600Mc/s. Values of field-strength for 50% of locations for 1kW radiated power by a half-wave dipole with vertical or horizontal polarization exceeded for 1%, 10%, and 50% of the time. (The dashed portions of the curves are less reliable than the portions shown in full lines.)

(iv) Finally, composite noises are recognized as having the combined characteristics of whistlers and ionospheric noise. Such "interactions," as they are termed, may be initiated by lightning discharges and are often associated with magnetic disturbances.

The continued study of this subject is helping to elucidate some outstanding problems on the nature of the earth's magnetism as well as on the physical characteristics of the upper atmosphere.

In this article, an attempt has been made to describe briefly some of the advances made, during

the past fifty years, in the study of the propagation of radio waves around our earth and also through its atmosphere.

Much has been learnt and understood about the physical processes and conditions involved: much more remains to be discovered; and interest in future research will be greatly quickened by the possibilities of the new tools available to the radio scientist in the form of rockets and artificial satellites and the associated measuring techniques and instruments.

INDUSTRIAL GROUPS—VI

The Victorian origin of the wireless industry in this country is apparent from this photograph taken in the Marconi works over 60 years ago.

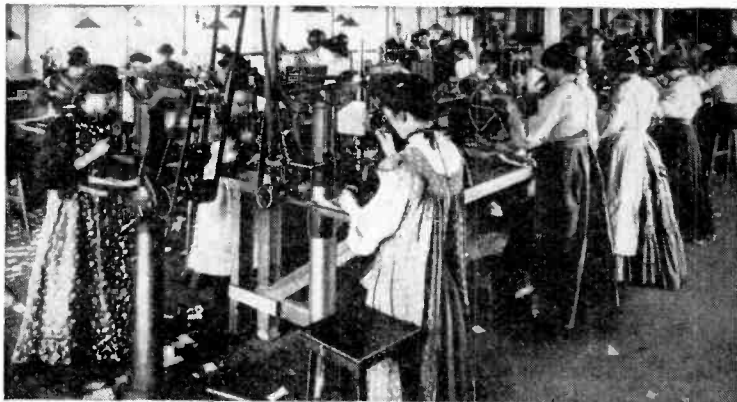

THE history of the Marconi company, and therefore that of the radio industry, started with the formation on July 20th 1897 of the Wireless Telegraph and Signal Company (soon afterwards renamed Marconi's Wireless Telegraph Company). Two years later the company established its first factory in Chelmsford, Essex. Since 1946 Marconi's W/T Company, together with its subsidiaries and associated companies has been part of the **English Electric Group**.

As will be seen from the following list the group,

English Electric Co. Ltd.
D. Napier & Son and its subsidiaries
Marconi's Wireless Telegraph Co. and its overseas subsidiaries
Marconi Instruments Ltd.
Marconi International Code Co.
Marconi International Marine Communication Co. and subsidiaries
Marconi Radio Sounding Device Co.
Marconi Television Co.
Radio Communication Co.
Scanners
Vulcan Foundry
Robert Stephenson & Hawthorns Ltd.
English Electric Valve Co.
English Electric Export and Trading Co
Canadian Marconi Co.
John Inglis Co., Toronto.
English Electric Canada
English Electric Company of South Africa (Pty.) Ltd.
English Electric Company (Central Africa) Ltd.
English Electric de Venezuela
English Electric Company of India (Pty.) Ltd.
English Electric Company of Australia Pty. Ltd.
English Electric Company of New Zealand Ltd.
English Electric Espanola
English Electrica de Portugal
English Electric Marconi Argentina
Associated Transistors Ltd.
British Aircraft Corporation and its subsidiaries
English Electric, Babcock & Wilcox and Taylor Woodrow Atomic Power Construction Co.
Kingsway Housing Association
Power Traction Finance Co.

of which Lord Nelson of Stafford is chairman, now comprises over 30 allied and associated companies. It employs 84,000 people in its 24 principal works in this country and abroad. The group's interests are too diverse to be covered adequately in a short survey, but they range from aviation to atomic power plant, electrical generation to electric cookers, traction equipment to transistors, marine engines to marine radio, transmitters to turbines, and klystrons to computers. Its radio and electronics interests are not, however, concentrated in the Marconi section of the group, for the English Electric Company itself has been in the forefront of the development of electronic computers and, jointly with the Automatic Telephone and Electric Company, operates Associated Transistors Ltd., manufacturers of semi-conductors. Also the English Electric Valve Company produces the "glassware" which is the very heart of the transmitters, radars, television cameras, etc., produced by Marconi's.

The English Electric group profit for 1960 of £3,142,580 (after providing nearly £3M for taxation) is slightly above the previous year's figure. The group has an issued share capital of nearly £33M, fixed assets of nearly £44M and current assets of £48M.

Reactance Calculator

A SLIDE-RULE Calculator measuring $8\frac{3}{4} \times 3\frac{1}{2}$ in providing a simplified means of calculating resonance frequency of tuned circuits, reactance of inductors and capacitors, Q of coils and dissipation factor, all over a wide range of values, has been introduced by Shure Brothers Inc. of Evanston, Illinois, U.S.A. It is, however, obtainable in the U.K. from J. W. Maunder, 22 Orchard Street, London, W.1, at the modest price of 12s 6d.

MANUFACTURERS' PRODUCTS

NEW ELECTRONIC EQUIPMENT AND ACCESSORIES

Fast Pulse Generator

WITH the American Du Mont Type 404 pulse generator the pulse width can be continuously varied from 0.05 to 100 μ sec and the pulse repetition rate can be continuously varied from as high as 100,000 down to 10 pulses/sec with internal triggering or, with external triggering, even down to a single pulse. The maximum allowable duty cycle is 10%, and a warning cut-out prevents higher duty cycle pulse trains from being generated. The pulse rise and fall times are at most 0.02 and 0.025 μ sec respectively and the overshoot less



Du Mont Type 404 fast pulse generator (Aveley Electric).

than 3%. The maximum peak pulse output is 50V \pm 10% (into 50 Ω) and this can be attenuated in $\frac{1}{2}$ dB steps up to 59.5dB to an accuracy of \pm 3%. The leading pulse can be delayed from 3 to 125 μ sec relative to an external 2V trigger with a jitter of less than 4m μ sec + 0.1% of the delay time. This generator costs £280 and is imported into this country by Aveley Electric Ltd., of Ayrton Road, Aveley Industrial Estate, South Ockendon, Essex.

Vacuum Switch

SHOWN in the illustration is the B. & R. Relays new Type 85 vacuum switch, a moderate-sized, single-pole make and break unit capable of switching loads of up to 2kW at voltages up to 3kV. The contacts are enclosed in an evacuated glass capsule fitted with metal end-caps and these provide the external electrical connections.

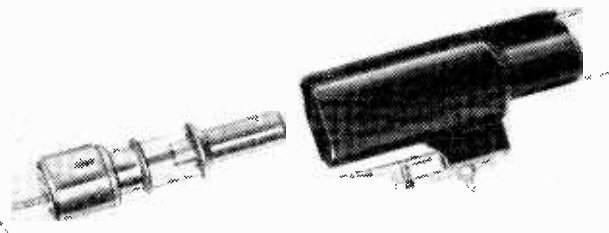

B. & R. Relays vacuum switch withdrawn from its plastic housing.

It is mechanically operated by means of the small rod seen projecting from the larger-diameter end-cap. This actuating rod is attached to a flexible diaphragm to which is fixed also the internal moving switch contact.

Although rated for relatively heavy loads a switch of this kind has many applications in radio and electronic equipments, especially where only very infrequent operation is required or highly inductive loads have to be switched. As the contacts are in vacuum they are protected against all forms of contamination.

The switch capsule is available separately as Type 183, and enclosed in the plastic housing shown in the illustration it becomes Type 85. Up to four Type 85 switches may be fitted to either an a.c. or a d.c. relay which will provide change-over or make and break facilities as required. These relays (Type C12 d.c., or C62 a.c. operated) consume about 6W (20VA a.c.) and are fitted with coils of 12k Ω nominal resistance. Further details can be obtained from B. & R. Relays Ltd., Temple Fields, Harlow, Essex.

Wide Range Communications Receiver

A COMPLETELY new communications receiver, the Type 51S-1, offering extreme frequency accuracy and operational simplicity has been introduced by the Collins Radio Company. Continuous coverage of the 2 to 30Mc/s range is provided in 1-Mc/s bands with 1-kc/s increments on the main tuning dial. Additional coverage from 0.2 to 2.0Mc/s permits broadcast monitoring or laboratory use. Reception of upper sideband, lower sideband, a.m. or c.w. signals is provided at any frequency within the tuning range.

A.G.C. characteristics and a separate product detector contribute to optimum s.s.b. performance. A rejection notch tuning feature provides at least 40dB attenuation of unwanted signals and a level meter may be switched to indicate either r.f. signal or audio output levels. Turret construction of the r.f. section results in increased efficiency and the R.F. gain may be remotely controlled, if required, by simplexing on the audio output line.

The 51S-1 receiver is fitted with a gray simulated leather panel and housed in a gray enamel cabinet. As the illustration shows the set not only has an attractive appearance but the controls are neatly and conveniently arranged. Operation is from either a 115 or 230V, 50 to 400c/s power supply. A 28V, d.c. model is also available. The receiver may be mounted in the standard 19in rack and a special fittings kit is available for this purpose.

It is understood that the price of the 51S-1 receiver



Collins new communication receiver, Type 51S-1 which has a very comprehensive specification.

is of the order of 1,920 dollars f.o.b. U.S.A. Further details can be obtained from Collins Radio Co. of England Ltd., 242 London Road, Staines, Middx.

Low Torque Precision Potentiometer

SPECIAL features of a new precision wire-wound potentiometer introduced recently by Miles Electronics are: low rotational torque, not exceeding 7gm/cm for any resistance value; multi-contact wiper assembly of

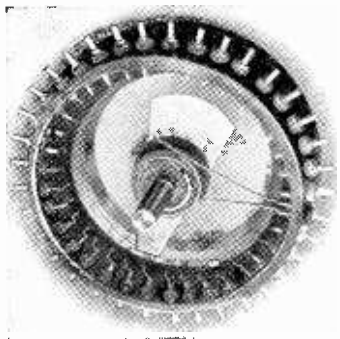

Miles Electronics precision potentiometer.

precious metal alloy; spindle carried in a miniature ball-race; intermediate tapings up to 33 in number and ganging of up to 6 units normally, and to 8 if specially required.

Resistance range is 0.5k Ω to 100k Ω in 8 standard values with a normal tolerance of 5%, but 1% can be supplied if necessary. The rating is 4.5W and the dimensions are 2 $\frac{3}{8}$ in diameter \times 1in deep.

Linear resistance elements are fitted wound normally with enamelled nickel-chrome or cupreous-nickel wire, but windings of precious alloy wire, such as silver-palladium, can be fitted if specially required.

Further details can be obtained from Miles Electronics Ltd., Shoreham Airport, Sussex.

Sound Spectrometer

WITH the new Advance Type SPM1 battery sound spectrometer sounds at frequencies between 20 and 12,000c/s and at levels between 20 and 150dB (referred to 2 \times 10⁻¹ dynes/cm²) can have their levels measured and can also be analysed by making use of the eight alternative filters provided. These filters consist of a low-pass filter covering up to 90c/s, six band-pass octave filters covering in all from 90c/s to 5,600c/s, and a high-pass filter covering upwards from 5,600c/s. The attenuations produced by these filters outside their nominal pass bands are, for the low-pass filter, 40dB at 450c/s; for the band-pass filters, 30dB at one half and twice the lower and upper cut-off frequencies respectively and 50dB at one quarter of and four times these

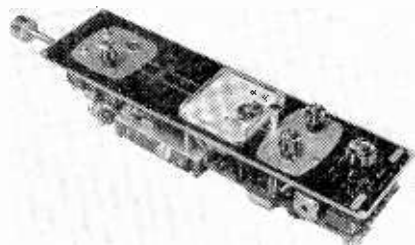

Advance battery sound spectrometer Type SPM1 with cover removed.

frequencies (except for the lowest octave (90-175c/s) filter for which these attenuations are somewhat less); and, for the high-pass filter, at least 40dB at 1,200c/s. This spectrometer costs £210 and is manufactured by Advance Components Ltd., of Roebuck Road, Hainault, Essex.

Transistor Analyser

RAPID and convenient measurement of many of the parameters of both p.n.p. and n.p.n. transistors is made possible by the Microcell Transistor Analyser type 440. The measurements are carried out in common-emitter configuration, and include current-gain, cut-off frequency, leakage current and turnover voltage. Diode characteristics may also be determined.

The signal source is a Wien-bridge oscillator which covers the range 1kc/s-10Mc/s, and which is amplitude stabilized to within ± 1.5 dB. Current gain up to a maximum of 200 is measured by a differential-input, wide band valve voltmeter, while collector voltage and

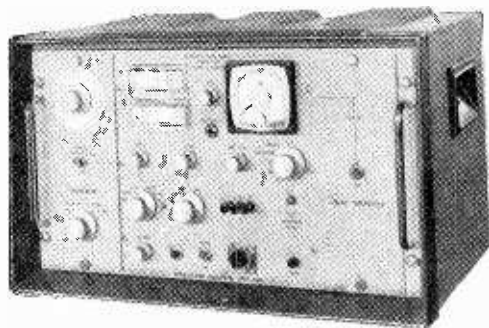

Microcell Transistor Analyser Type 440.

current are continuously adjustable up to 100V and 3A respectively, and are monitored by edge reading meters. External adaptors may be used to determine "h" parameters.

The instrument is obtainable from Microcell Electronics Division, Blackwater, Camberley, Surrey.

Tape Revolution Counter

SUITABLE for use with Scotch Boy 5 $\frac{1}{4}$ in and 7in and Emitape 7in reels, the "Call-Boy" revolution counter is attached to the supply spool by a three-pronged rubber clip. The three-digit resettable counter is driven



Colton "Call Boy" tape revolution counter.

from this clip via a flexible shaft, and can be attached to any smooth surface by means of a suction cup. The "Call-Boy" costs 42s 6d, and is manufactured by Colton & Co. (Lapidaries) Ltd., of The Crescent, Wimbledon, London, S.W.19.

TECHNICAL NOTEBOOK

Radio Star Survey recently reported by Ryle showed that, per unit angular area of sky, the number of radio stars increases rapidly as their intensity decreases. Even when the many possible modifying factors are allowed for, this result corresponds to an increase in the density of radio sources with increasing distance. Bearing in mind the time taken for the radio noise to travel from its source, this result thus also corresponds to an increase in the density of radio sources at increasing times in the past. It is this final deduction which appears to support theories in which the mean density of matter in the universe decreases with time (evolutionary theories) rather than theories in which this density remains constant (steady-state theories). (In steady-state theories, in order to nullify the decrease in density which would otherwise be produced by the expansion of the universe, continuous creation of matter must be postulated.) Most of the radio sources are vastly more intense than their optical counterparts and so can be observed to far greater distances. The increase in density in fact only becomes noticeable beyond the limit reached by present-day optical telescopes.

C.W. Optical Maser has been recently developed at the Bell Telephone Laboratories. Unlike the pulsed optical maser which was also recently developed by Bell and which was described in the Technical Notebook section of our December 1960 issue, the new maser uses a gas (a mixture of helium and neon) rather than a solid (ruby) as its active material. An ordinary low-power ($\approx 10W$) electrical discharge is used to excite the helium atoms. These atoms collide with the neon atoms and in the process excite them in

turn to one of four upper energy levels. Transitions of the neon atoms to one of ten intermediate energy levels can then be stimulated, continuous radiation (at a level of the order of 0.01W) being emitted as the transitions take place. Thirty different transitions are in fact possible, so that there are thirty possible maser emission wavelengths. These all lie in the infra-red between 9,000 and 17,000Å: operation at five of them (between 11,000 and 12,000Å) has at present been observed. As in the Bell ruby optical maser, semi-reflecting accurately-parallel end-plates are used to reflect the stimulated radiation back and forth along the gas-filled tube and thus to increase its intensity. Some of the stimulated radiation passes through the end plates forming a beam whose spread is less than a minute of arc in the case of the new gas maser. The spectral line width of this new maser is more than one hundred thousand times narrower than that of the ruby maser, and more than one thousand times narrower even than the narrowest hitherto-obtainable optical lines. This very narrow line width has already permitted the first observation of difference signals at radio frequencies between two optical lines. Broadband modulation of the beam at frequencies up to 60kc/s has also been accomplished using a Kerr cell.

Piezoelectric Ignition is used in the U.S. Clinton industrial engine shown by Trojan at the recent Smithfield Show. This ignition system utilizes the voltage developed by compressing a piezoelectric material—in this case PZT (the trade name for the lead zirconate titanate group of ceramics). In the ignition unit the PZT is enclosed in a plastic container which is squeezed by a lever mechanism driven off the crankshaft or camshaft. The generated voltage is fed to the sparking plug via a timing switch which can be operated from the flywheel. Thus no capacitor or spark coil is required. With this ignition system the voltage generated is nearly independent of the engine speed so that starting is made easier. The voltage rate of rise can also be made fast enough ($\approx 10^6V/\mu\text{sec}$) to fire sparking plugs which seem to be fouled when used with ordinary ignition systems.

These units can be made very small (occupying only $3\frac{1}{2}$ cu in) and light (weighing only 8oz). In this country, PZT is manufactured under licence, by Brush.)

Very-Low Distortion single-ended push-pull audio output stage is described by C. T. Murray in the March 1960 issue of *Proc.I.R.E. Australia*. The basic circuit is shown in the diagram. From this it can be seen that, whereas one of the two output valves, V1, is fed directly

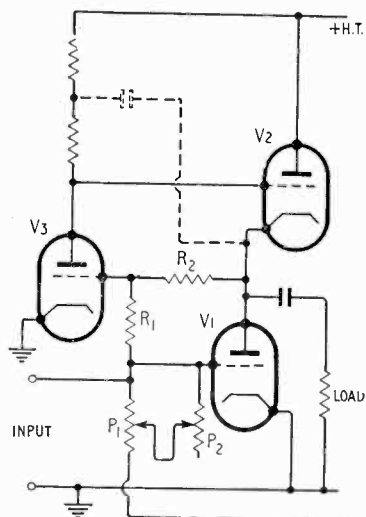

from the input, the other output valve, V2, is fed from an amplifier, V3, which is itself fed both from the output and from the input. The low distortion results from the fact that any distortion in the output is amplified and phase reversed by V3, and then fed back to V2 so as to oppose the distortion produced in the load by V1. V3 must be fed with the correct fraction (determined by R_1, R_2, P_1, P_2) of the input and output voltages to produce a signal input to V2 equal to that to V1 and thus to correctly balance the push-pull stage. The negative supply is used to back off the positive voltage at the cathode of V2 and thus produce the correct voltage at the grid of V3. The dotted capacitive "bootstrap" connection shown both ensures that V3 can provide sufficient drive for V2 and effectively increases the gain of V3 and thus still further reduces the distortion. With this type of circuit at full output a total harmonic distortion of only 0.02% was achieved without applying any overall feedback.



INTERNATIONAL ELECTRONIC COMPONENTS SHOW



Salon International des Composants Électronique, Tubes et Accessoires Électronique Paris, 17-21 February, 1961

ALTHOUGH this annual exhibition has for the past four years been open to foreign exhibitors it still retains much of the character of the old French Components Show which started in 1934. Of the total of 435 stands about three-quarters were taken by French exhibitors, the remaining quarter by firms from eight other countries among which Germany (28), United States (27) and Great Britain (21) predominated. As in recent years the décor of the stands was uniform and the width of the *allées* ample, allowing those who wished, to saunter without impeding the movement of any with more urgent business (e.g., journalists?). To look at every stand it was necessary to walk at least a mile—two if both sides of each avenue were examined in detail.

Electronic accessories and measuring instruments are admitted, but

the show remains predominantly one of *pièces détachées*. The fact that most of the products had been seen in previous years can be taken as indicating their general acceptability, but there were enough *nouveautés* (so marked by stick-on labels) to keep interest alive. A wide range of very small components for printed wiring and of tuner, i.f. and a.f. "modules" for incorporation in small portables were shown by Orega (a subsidiary of C.S.F.). Both Orega and S.E.C.R.E. (Soc. d'Études et de Constructions Électroniques) were showing fixed inductances, with end wires resembling fixed resistors, for use in filters and similar applications. S.E.C.R.E. here also introduced, in addition to their lumped-constant delay lines, a range of distributed-constant lines in moulded form with end wires for suspension in circuit wiring.

For test and measurement a num-

OS601 (7 to 11kMc/s). A special stabilized power supply (SCF 300) is available for these klystron oscillators. Solartron were showing their decade pulse generator (GO1005) which has a p.r.f. range of 10c/s to 1Mc/s and pulse width variable from 250m μ sec to 100msec $\pm 5\%$. A lightweight transistor a.f. generator shown by S.E.C.R.E. working in conjunction with a transistor frequency meter with direct-reading, 6-decade luminous display were recent additions to their range of measuring instruments. Quartz-controlled transistor oscillators with self-contained 9-V battery in cylindrical cans 22mm in diameter and from 600 to 100mm high have been produced by Quartz et Électronique. Frequencies between 1kc/s and 1Mc/s are available and typical characteristics (for the 1Mc/s oscillator) are: output 700mV (impedance 1500 Ω); distortion $< 5\%$; stability 18c/s (-60° to $+90^\circ$ C).

Powers in excess of 5mW at a frequency of 2.2kMc/s are provided by an all-solid-state generator shown by Philco and developed in the Lansdale Division. Improvements in efficiency of up to two orders of magnitude, compared with klystrons, are claimed and the power supply is four 4-volt mercury cells. The total volume of the equipment is about 100 cubic inches and the weight 4lb. A crystal-controlled 110Mc/s oscillator (2N1158) is followed by a "field flow" (L5437) transistor amplifier which raises the signal level to 100mW. This is then applied to a varactor (L4105) harmonic generator and the fourth harmonic selected. After passing through a bandpass filter the 440-Mc/s signal is applied to a further varactor (L4102) and the fifth harmonic (2.2kMc/s) selected. It is claimed that the unit is particularly

Right: Encapsulated fixed inductors (Orega).

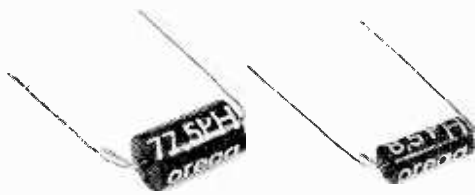

Below: Pair of i.f. coupling transformers for transistor printed circuits. $Q > 160$; dimensions 20 x 13 x 13mm (Orega).

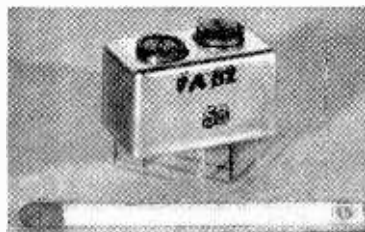

ber of new signal sources made their first appearance. Metrix were showing a response curve tracer for v.h.f. covering a frequency range of 5 to 220Mc/s and comprising an assembly of wobblator, marker and c.r. oscilloscope units which can be used separately. Férisol have added two new high-level (40mW) oscillators to their range of microwave signal generators: Type OS501 (4 to 8kMc/s) and Type



Transistor a.f. generator and transistor frequency meter (0 to 1 Mc/s) shown by S.E.C.R.E.



Test instrument for routine measurement of carrier lifetime in semiconductors (J. L. Amiot).

suitable for airborne and space applications (rechargeable nickel-cadmium batteries can be used if the duration—100 hours—of the mercury batteries is inadequate). The frequency stability is suitable for a Doppler system local standard, and amplitude modulation can be applied through variation of the varactor bias.

Ribet-Desjardins were showing a new signal generator (428A) with a

constant-level output $\pm 2\%$ over the frequency range of 10kc/s to 30Mc/s and a laboratory type wobulator and oscilloscope (411A) covering 0 to 320Mc/s in three ranges. Modulation is ± 10 Mc/s for the middle range (80-160Mc/s) and ± 20 Mc/s for the upper and lower ranges. Solartron were showing a neat double-beam oscilloscope (CD1016) for rack mounting, covering 0 to 5Mc/s and also a portable double-beam oscilloscope (CD1014). Another interesting Solartron portable instrument shown at this exhibition for the first time was a transistor direct-reading frequency and capacitance meter covering 0 to 10kc/s in seven ranges and 0 to $0.3\mu\text{F}$ in six ranges.

Equipment for the routine testing of carrier lifetime in semiconductor specimens has been developed by J. L. Amiot. It makes use of the fact that intense illumination can be used to produce minority carriers. The

specimen under test is placed over a hole in a horizontal shelf on the front of the instrument and connected in series with a resistance to a d.c. source. Light from a flash tube with a pulse duration of, typically, 10^{-7} sec is concentrated by a mirror and lens system on the underside of the specimen. The output signal from the specimen triggers a sawtooth time base which runs until the signal falls to 1/e of its initial value, when the time-base voltage rise is stopped and the time-base returns to zero. The sawtooth maximum is read by a peak voltmeter which is calibrated to give direct readings of carrier lifetime.

Incidentally, a small portable flash stroboscope was chosen by Ferranti as an example of an application of their four-layer p-n-p-n switching diodes.

Sound level meters were shown by several firms. Many of these are transistor instruments, e.g., the "Minophon" pocket instrument made by the Swiss firm of Ing. Heinrich Spyri S.A. which measures only $125 \times 85 \times 40$ mm; and the Sonomètre S.S.T.1 made by Laboratoire Electro-Acoustique (LEA) which incorporates checking facilities for battery voltage and amplifier gain.

A "wireless" microphone demonstrated by Sennheiser made use of a transistor pocket f.m. transmitter working on 35Mc/s and was effective at considerable distances from the stand under adverse exhibition conditions, showing no signs of interference pick-up.

Sonocolor mounted an effective demonstration of magnetic recordings as revealed by the Bitter technique, of applying colloidal iron oxide and then viewing the patterns produced on the screen of a projection microscope.

Many interesting audio exhibits were seen, but as these were also shown at the Festival of Sound in the Palais d'Orsay in March they are described elsewhere in this issue.

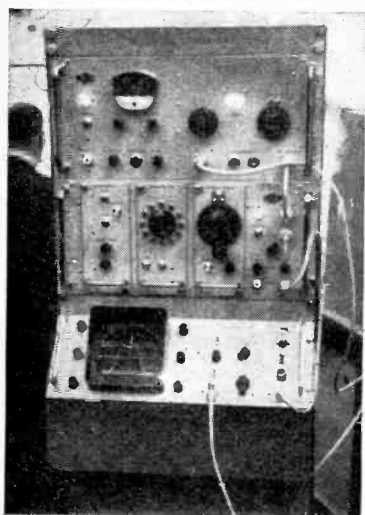

Response curve tracer for v.h.f. (Metrix).



Above: Transistor noise level meter for hand or stand (L.E.A.).

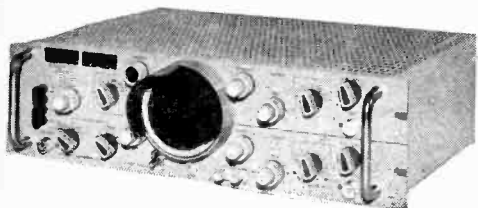

Left: Type CD1016 double-beam oscilloscope (Solartron).

Response Curves and Tone Quality

By M. G. SCROGGIE, B.Sc., M.I.E.E.

AMPLITUDE/FREQUENCY response curves have had their ups and downs, in more senses than one. Until about 1925 the reception of programmes by radio was considered so wonderful that it would have seemed churlish to criticize the quality of reproduction. Effort was still being concentrated mainly on the feat of being able to hear them at all. But as the art of amplification reached the stage of ensuring adequate volume, people began to get quality-conscious. Technical enthusiasts, then as now, were unimpressed by the inevitable slogans—"Perfect Tone," "Reproduction Absolutely Indistinguishable from the Original Performance," etc.—and wanted scientific evidence. This first came in the form of amplitude/frequency response curves, hereinafter to be called just "response curves."

The typical a.f. amplifier of the period comprised two transformer-coupled stages (sometimes more than two!), the response curve of which consisted mainly of a fairly sharp peak somewhere in the range 1-3 kc/s. Clearly such curves were commercially unpublishable, but may have had something to do with the rapidity with which amplifier design began to progress. What the amplifier was doing below 300 c/s—or not doing, more likely—was at first concealed by the linear frequency scale (Fig. 1).

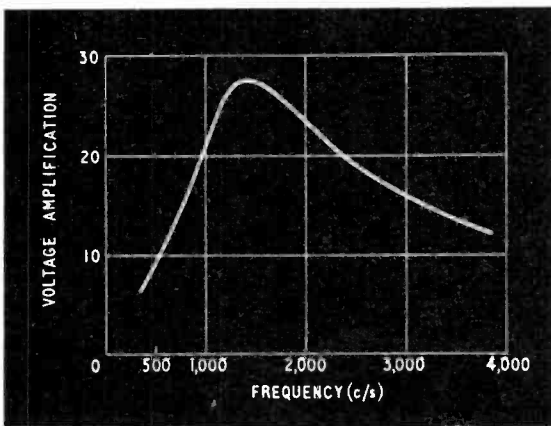

Fig. 1. Response curve of a single-stage transformer-coupled amplifier dated 1925.

Ferranti deserve remembrance for their pioneering of level-response a.f. transformers and publication of logarithmic frequency curves (if they could be called curves in their case!) with which to commend them factually. Soon, however, the development of r.f. tetrodes was to render a.f. transformer coupling unnecessary, and resistance coupling gradually superseded it. By about 1927, a.f. amplifiers had so much improved that even overall response curves began to be worth advertising. And so the passion

for high-quality sound reproduction gained momentum. Loudspeakers were still extras, however, externally connected and not included in the price of a broadcast receiver, so naturally they did not come within the scope of the response curves—which was fortunate for the advertisers.

For some years a response curve was almost the only available objective index of tone quality, and enthusiasts attached great importance to ironing out every fraction of a decibel departure from perfect horizontality, regardless of what the loudspeaker and listening room were doing—a striking example of straining at a gnat and swallowing a camel. Some attention was beginning to be given to non-linearity, but mainly among the technical *avant-garde*. Outstanding was an article by J. H. O. Harries¹ in which he brought forward experimental evidence that the largely third-harmonic distortion generated by pentodes sounded worse than the same amount of triode distortion (mainly second-harmonic).

As the frequency range of a.f. amplifiers—and to a lesser degree other equipment such as pickups and loudspeakers—continued to be extended, a controversy arose as to the desirability or otherwise of such development, especially at the top end of the scale. Some held uncompromisingly that the higher the fi-er; others, while generally conceding this as an ideal, argued that noise, interference, and (dare one whisper it?) distortion made it expedient to cut off everything above, say, 5,000 c/s. Capt. P. P. Eckersley had, as usual, a memorably picturesque way of putting it—"The wider the window is opened, the more dirt comes in." This controversy, challenging the validity of the response curve as a measure of fidelity, reached a peak of intensity in the correspondence columns of *Wireless World* during 1932, and continued indecisively until smothered by the outbreak of war.

The end of the war released a greatly augmented number of enthusiasts, amateur and professional, to pursue the search for perfect sound reproduction. Almost at once the "flat from 20 to 20,000" school of thought—and with it the prestige of the response curve—received a severe blow by the publication of experiments by Chinn and Eisenberg² which produced an impressive mass of evidence to show that few listeners had any use for reproduction of frequencies outside 70-6,500 c/s, and many chose to be restricted to 150-4,000 c/s. This was what a lot of people, including the more successful manufacturers, had believed for a long time, but it was no doubt comforting for them to find that their heresy had suddenly become respectable.

As was to be expected, the orthodox reacted vigorously, and many attempts were made to discredit the findings of Chinn and Eisenberg. The

¹ "Amplitude Distortion," *Wireless Engineer*, Feb. 1937, p. 63.

² "Tonal-range and Sound Intensity Preferences of Broadcast Listeners," *Proc. I.R.E.*, Sept. 1945, p. 571.

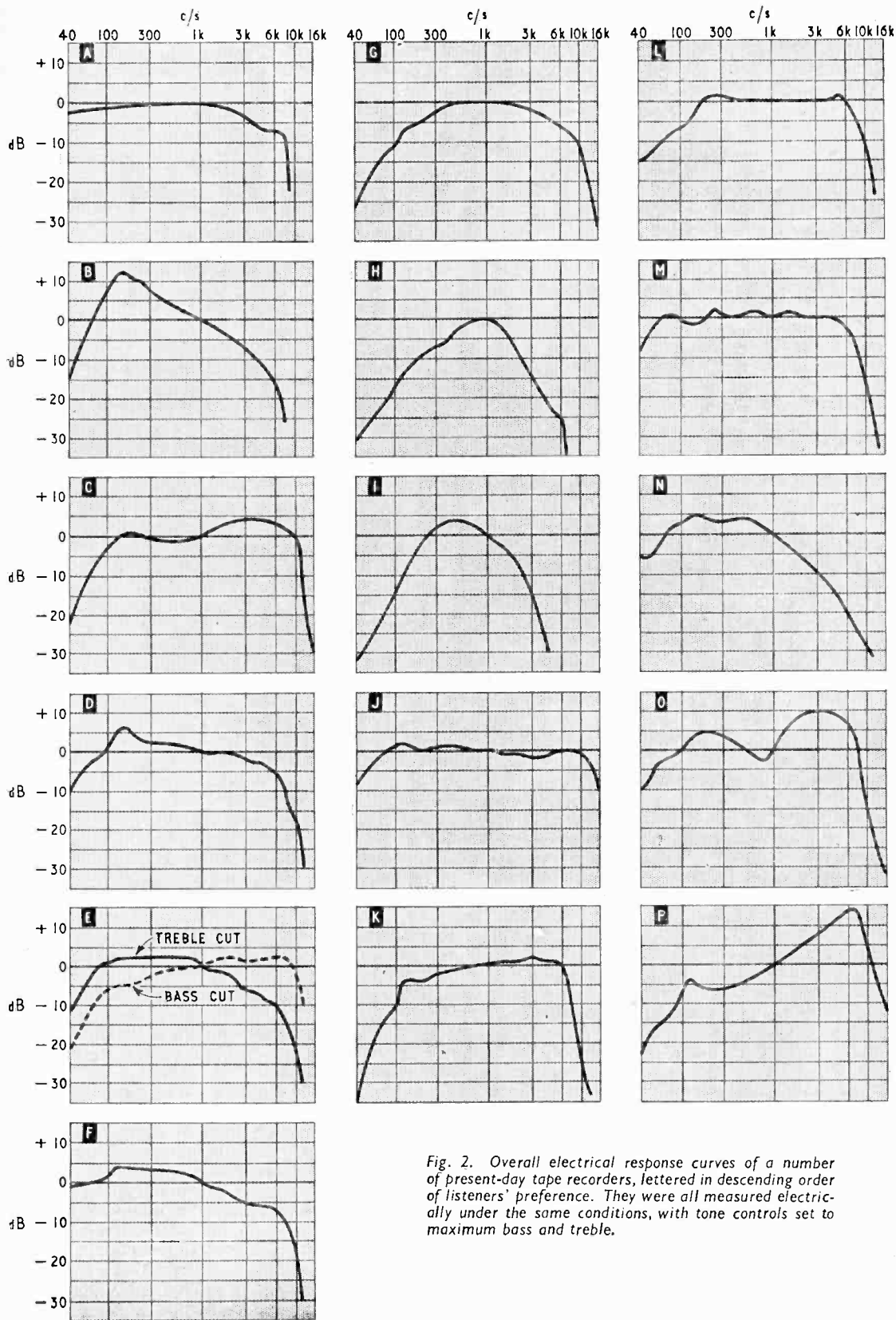

Fig. 2. Overall electrical response curves of a number of present-day tape recorders, lettered in descending order of listeners' preference. They were all measured electrically under the same conditions, with tone controls set to maximum bass and treble.

main weight of the attack was launched against their statement that distortion from the equipment used for the experiments was imperceptible to the most highly critical listener. Clearly (it was said) the lack of enthusiasm for the widest window must have been due to harmonic and intermodulation dirt too fine to be detected as such but nevertheless spoiling the reproduction. Otherwise—and this was their trump card—the original sounds themselves would be unacceptable if heard with their full natural frequency range.

Direct Hearing

Not long afterwards H. F. Olson³ took them up on this point by testing listeners' preferences in the same room with the original sounds, no electrical apparatus being used. It was something of a shock to read that about a third of the listeners preferred to hear the music and speech restricted to a top frequency of 4,000 c/s by means of an acoustical filter. The shock was considerably allayed when one read on and learned that from overhearing the comments made afterwards by the listeners it could be concluded that those who voted for the restricted hearing were mainly those who disliked the programmes anyway, so would naturally be glad to hear as little of them as possible. That even a small minority should prefer sounds to be muffled—especially speech, which is so often heard naturally that nobody would regard loudspeaker reproduction as the standard—does, however, seem to call for some explanation by the authorities who insist that anything less than 15,000 or even 20,000 c/s is not good enough.

The difference between the results of the two sets of experiments—especially if allowance is made for those who were merely using the only means open to them to protect themselves from Mr. Olsen's programmes—is sufficiently marked to give possible or even probable support to the unmeasurable-distortion theory. It seems that many listeners who prefer to hear original sounds with all their crispness would reach for the "top cut" control if they were presented with even the highest-fi reproductions of them. Complete proof is lacking, however, because Chinn and Eisenberg's reproductions were monophonic, and it can be argued that the difference between this and direct (or stereophonic) hearing may affect the preferred frequency range. So far from stopping to straighten out this tangle, I am pausing, just long enough to add the observation that members of my family consistently tolerate much more "modern" symphonic music when they hear it direct than via hi-fi. But that may be merely because their attention is diverted by the antics of the executives.

The last decade seems to have brought forth little to aid interpretation of response curves or restore confidence in them. Nevertheless, and in spite of the obstinate refusal of the ordinary listener to prefer what he ought to prefer—full frequency range reproduction—there is still a tendency to assume that the higher the top frequency that can be advertised the higher the "fi" it implies. Recently I had occasion to see some frequency response measurements on tape recorders which were also judged by

systematic listening tests, and thought a comparison might be instructive. The tests were carried out under the auspices of the Consumers' Association Ltd.

Measurements and tests were made under like conditions on all models, and (with exceptions to be mentioned) the listening tests were under conditions similar to those for the response measurements. All were at 3 $\frac{3}{4}$ in/sec tape speed.

The measurements were made by recording sinusoidal signals at 27 frequencies from 40 c/s to 16 kc/s, the a.f. source being connected to the microphone input. The tape was then played back and the power output into rated load was measured. The ratio of output to input overall was expressed in dB relative to that at 1 kc/s. Tone controls were set to give maximum bass and treble, except Model E, in which there was only a single tone control, which was set at its extremes and two separate curves taken.

The listening tests likewise embraced recording and replay, and also the microphone and loudspeaker included in or prescribed for the recorder; this of course was a significant difference in conditions. Another difference was that the tone controls were adjusted by the panel of three listeners to what they judged to be optimum settings. In each case one male and one female speaker were recorded "live," and also some piano playing. The tone quality for each was separately assessed by each of the listeners, who awarded marks out of 100. They were not aware of the names of the machines being heard, or of their measured characteristics. Scores were weighted in the ratio 2 to 1 for piano and speech respectively. The results quoted here are the overall averages for the panel. In most cases the three listeners' scores were reasonably similar, but a minority showed a wider spread from average.

The response curves are arranged in Fig. 2 in descending order of listener preference. The corresponding average scores are as follows:

Model	Score	Model	Score
A	58	I	35
B	57	J	34
C	51	K	34
D	51	L	32
E	48	M	32
F	47	N	30
G	38	O	29
H	37	P	16

To forestall one query that might be made on comparing the curves with this table, mention should be made that harmonic distortion measurements were also carried out, but do not shed any certain light on the matter. For listening, the output level was kept low, in a room of average domestic size.

One's first conclusion, especially after noting the widely different placings of B and N despite the similarity of their curves, might well be that response curves couldn't matter less. More mature consideration is likely to reduce this to some such statement as that response curves are not an entirely safe index of tone quality. With regard to B and N in particular, it should be mentioned that they were about the least consistently judged, and also that the excessive bass

³ "Frequency Range Preference for Speech and Music," *J. Acous. Soc. Amer.*, July 1947, p. 549.

in B could be and probably was reduced by the listeners' tone adjustments. A more damaging comparison is that between the exemplary curve of M and its mediocre placing.

The first definite conclusion could be one in harmony with Chinn and Eisenberg—that response above 7 kc/s is not essential for pleasing reproduction (note A and B). Furthermore, an excess of very high frequencies is particularly distasteful (P). A more puzzling conclusion is that a very narrow response, so long as it comes well in the middle (H and I), is not wholly unacceptable to listeners; it can in fact be preferred to more level curves (J, K, L and M). An interesting point is that in general the machines with the most level curves were the most consistently judged by the listeners.

Almost certainly the picture would have differed somewhat if the overall response tests had been really overall, including microphone and loudspeaker, and been measured at the listeners' tone control settings; but since most of the response curves presented by manufacturers are obtained under conditions similar to those shown here, the general conclusions stand. It is doubtful whether they would have been far out even if the conditions had been identical to those for listening.

Audio Festival Exhibitors

MANUFACTURERS from the Continent, Japan and the U.S.A. are among the 72 exhibitors at the International Audio Festival, which opens at the Hotel Russell, London, W.C.1, on April 6th, for four days. In addition to the usual demonstration room for each of

AKG
Acoustical
Allied Records
Ampex
Armstrong
Audio Fidelity
Aveley Electric

BASF
Brenell Engineering
British Ferrograph

Challen Instrument Co.
Chapman (Ultrasonics)
Chitnis Electronic A.G.
Ciné Accessories
Clarke & Smith
Collie
Cosmocord

E.M.I. Records
E.M.I. Sales & Service

Faraday Electronic Insts.
Fi-Cord (Distribution)
Field, N. S. B.

Garrard
Gevaert Photo-Reproduction
Goodmans
Gramophone Co.
Grampian
Grundig

Leak
Lowther
Lustraphone

M.S.S. Recording
Magnavox

Minnesota Mining & Mfg.
Mullard
Multimusik

Orr Industries

Pamphonic
Philharmonic Records
Philips
Projection

Radford Electronics
Robuck Electrical Industries
Rogers Developments
Rola Celestion

S.M.E.
S.T.C.
Schwarzalder Uhrwerke-
Fabrik Burger
Shure
Simon Sound Equipment
Sony
Sugden

Tannoy
Tape Recorders
Telefunken
Teppaz

Veritone
Vitavox
Vortexion

Wellington Acoustic Labs.
Wharfedale
Whiteley Electrical
Wyndor Recording Co.

Zonal Films

the manufacturers listed there will be an audio theatre, seating 200, in which frequent lecture-demonstrations will be given.

Tickets for the Festival, which is open from 11.0 to 9.0 each day, are obtainable from manufacturers, audio dealers or from *Wireless World*. Until 4.0 on the first two days admission is restricted to the trade.

CLUB NEWS

Barnet.—H. W. Pope (G3HT) will speak about d.f. gear to members of the Barnet & District Radio Club on April 28th. The club meets on the last Tuesday of each month at 8.0 at the Red Lion Hotel.

Birmingham.—April meetings of the Slade Radio Society include a talk on the 7th on transistors by N. B. Simmonds and another on the 21st on 2-metre amateur gear. The club's first d.f. contest of the year will be held on April 23rd. Slade Radio Society meets at 7.45 at Church House, High Street, Erdington.

Bury.—Future meetings of the Bury Radio Society will be held at 8.0 at The Knowsley Hotel, Kay Gardens. At the April 11th meeting K. Taylor (G3NNW) will talk on "My First Eighteen Months."

Derby.—Meetings of the Derby & District Amateur Radio Society, which incorporates the Derby Wireless Club formed in 1911, are held each Wednesday at 7.30 at 119 Green Lane.

Guildford.—Maurice Child will speak on "The Early Development of Radio" at the April 13th meeting of the Guildford and District Radio Society, which meets on the 2nd Thursday and 4th Friday of each month at 7.30 at the City Cafe, Onslow Street.

Halifax.—At the April 4th meeting of the Halifax & District Amateur Radio Society H. Swift (G3ADG), the club's chairman, will speak on efficiency modulation. The society meets on alternate Tuesdays at 7.30 at the Sportsman Inn, Ogdens.

Leeds.—Mobile equipment is the topic of the talk to be given to H. Brooks (G3GJV) at the April 12th meeting of the Leeds Amateur Radio Society. Meetings are normally held at 7.45 each Wednesday at Swarthmore Education Centre, 3 Woodhouse Square, but on April 26th members are visiting the Batley Works of Fane Acoustics.

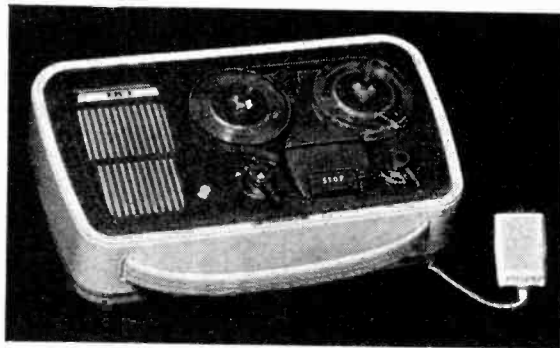

Transistor Battery Tape Recorder recently introduced by Grundig, the TK1, is shown in the photograph. At the operating speed of 3½ in/sec the frequency response is 80 to 8,000 c/s ± 3dB and the total wow and flutter 1%. The output power is 250mW. High-frequency bias is used and permanent-magnet erase. The weight of this recorder is 8lb and its dimensions 11¼ in by 7 in by 4½ in.

SOME THOUGHTS ON INDUCTANCE

HENRYS OR VOLT-SECONDS?

By THOMAS RODDAM

IN recent months I have been constrained to think about a variety of devices in which a coil is wound on a piece of ferromagnetic material and a current is passed through the coil. The practice of my temperate youth was to restrict the current so that this system remained linear, or fairly linear anyway, air gaps and extra iron being added whenever it became necessary to avoid the unwanted non-linearities. The characteristic property of such an arrangement is, of course, its inductance and it has become a matter of habit to assume that a thing having this sort of construction will also have associated with it the inductance-property, the idea of an inductance, the pure characteristic to which in this imperfect world we can only approximate.

There are now, however, a number of what appear to be inductance-devices which seems to have lost this old, this familiar, inductance property. Clearly the essential characteristics of a coil wound on a ferromagnetic core are unaltered by the circuit in which it is connected and the defect must therefore be one of understanding. One great aid to clarity of thought is freedom from reference books: it is therefore my practice annually to abandon my library and retire to some inexpensive retreat where the gentle susurrations of the rain and the heavier patter of the boots of a large but inefficient hotel staff can encourage the search for comprehension.

What, then, is an iron-cored coil? Digging into memory I recall that the passage of a current produces in the core a magnetomotive force, H , which is proportional to the current and to the number of turns and which is the same sort of thing as an

electric field in that it is proportionately diluted by the length over which the current acts. In fact

$$H = 4\pi NI/10l$$

The effect of this magnetomotive force H is to produce a magnetic flux. This is where the energy is stored in the magnetic system. We commonly write the simple equation

$$B = \mu H$$

to express the connection between the flux and the m.m.f. but although I quote this highly memorable equation further exploration shows that its use is attended with some danger.

A safer approach is based on the fact that when we change the flux which links the turns of a coil we produce a voltage across the terminals. The equation connecting these factors is

$$V = NA \cdot 10^{-8} \cdot dB/dt$$

where A is the area.

From these two equations we can go on to consider the very important term dI/dt . Since

$$I = (10l/4\pi N) H$$

$$\frac{dI}{dt} = (10l/4\pi N) \frac{dH}{dt}$$

Now let us define the inductance by the equation

$$L dI/dt = V$$

and we find that

$$\begin{aligned} L &= \frac{NA \cdot 10^{-8}}{(10l/4\pi N)} \cdot \frac{dB/dt}{dH/dt} \\ &= \frac{4\pi N^2 A \cdot 10^{-9}}{l} \cdot \frac{dB}{dH} \\ &= \frac{4\pi N^2 A \cdot 10^{-9}}{l} \cdot \mu \end{aligned}$$

When $B = \mu H$ we obviously have $dB/dH = \mu$ and the expression for the inductance has a similar form. When, however, this simple proportionality between B and H no longer holds the expression for inductance in terms of dB/dH is still true. The only trouble with it is that it depends on this differential term, which in strictness we must remember is actually $(dB/dt)/(dH/dt)$. This is by no means a pedantic distinction, as we shall see at a later stage. It retains in our equations the very important element of time. For engineering purposes you cannot put the clocks back and any expression containing time has built into it an arrow showing which way you are going.

Let us now look at the sort of relationship which we may encounter between B and H with some of the specially prepared ferromagnetic materials. The typical form is shown in Fig. 1, and it will easily be

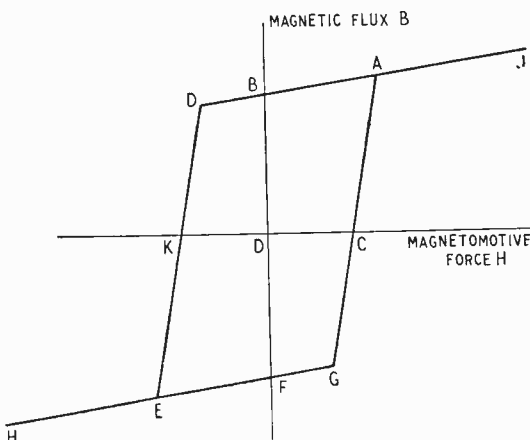

Fig. 1. Idealized B - H characteristic of a "square-loop" ferromagnetic material.

appreciated why materials which give a close approximation to this are called "square-loop" materials. First of all note that there is no indication in this diagram of what happens near the origin. This is rather a consequence of the way in which the square-loop materials are used than of their properties. In the region of the origin there is, in fact, a fairly conventional high-permeability loop. When used in this way a coil wound on such a core has an inductance of conventional meaning. One material which is of value in both modes is Mumetal.

In considering the square-loop behaviour of a core of this kind it is most convenient to start off by passing a very large current through the coil so that the flux is brought up to the point J. We now reduce the current without reversal to zero and after passing through A we follow along the line AB to the point B. Here the magnetomotive force H, and equally the current, is zero, so that we can disconnect the circuit. The core, however, remains magnetized with a stored flux B.

Connected back in circuit we apply a small current in the reverse direction along the path BD. The change in flux is very small so that the inductance, as we have defined it, is also very small. As we continue to increase the current we reach the point D. Quite suddenly dB/dH changes to a very large value, for the jump in flux from D to E involves only a small change in magnetomotive force. The inductance for this region traversed in this direction is very high. When we reach E we turn sharply again towards H and the inductance is again low since EH is almost parallel to the magnetomotive force axis.

The description of the changes in inductance in the last paragraph depends on our definition of inductance in terms of the volts per ampere per second, the tendency of inductance to prevent changes in current. We could also consider inductance in its energy storage character: if a current is flowing through an inductive element the stored energy is $\frac{1}{2}LI^2$. It is this property which makes inductance such an important element in filter theory, where the network elements must hold the energy introduced at stop-band frequencies and then force it back to the generator. I would remind you that a filter using only inductance and capacitance cannot actually attenuate a signal passing through it as there is nowhere for the energy to be dissipated. Such filters operate by presenting a reactive load to the generator in the stop band so that the energy is all flung back.

In this sense of inductance the word seems to have practically no meaning when the device is operated

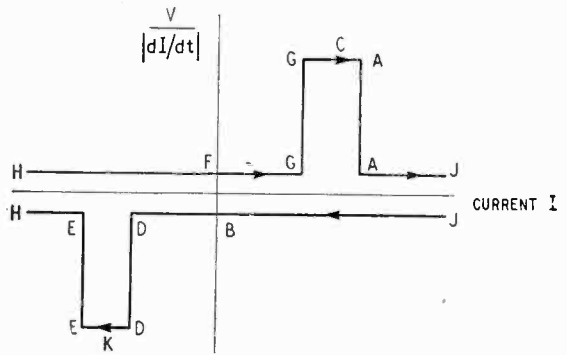

Fig. 3. An alternative way of drawing Fig. 2.

round the loop shown in Fig. 1. The stored energy has become virtually inaccessible and certainly unpredictable for any pattern of current other than a regular full excursion from H to J and back again. The energy which we force in up the path GCA is locked up in the remanent flux at the point B when we try to get it back: to move from C to A we find we are putting energy into a high inductance device and the small current (and m.m.f.) change takes a good deal of energy but when we try to get it out again the device decides to be a low-inductance one. It is all rather like the operations of a bucket shop or some new fairy story in which the princess when kissed turns into a frog, though these columns are no place for comments on marriage.

By now, no doubt, several familiar figures are reaching for their reference books, their slates and pencils. How many readers, I wonder, traced their first faltering characters, to the accompaniment of excruciating squeaks, on the economical slate: how long before their children complain that electric typewriters have not been provided for every infant in the village school? But s.f.f. are on my track with the revelation that if I consult Ezekiel Spanheim I shall find a clear definition of inductance which will dispose of all these difficulties. This I do not doubt, but neither do I doubt that the trick of producing such a clear definition is to restrict one's thought to ideal linear systems. Once we do this it is not really important which definition we adopt, since the alternatives can be easily and unambiguously derived.

What is the circuit designer to do? He is not concerned with magnetic flux and magnetomotive force: he has a black box with two terminals and has to define its properties in terms of voltage and current at these terminals. As a user of this black box it is merely vulgar curiosity which excites him to enquire why the behaviour is as he finds it. There are two experiments which he can profitably conduct. These will define the properties of his two-terminal device in a form which he can use.

In the first experiment a source of current is required. This, of course, is a circuit which produces a specified current no matter what the impedance through which the current must be driven may be. There are a number of ways of approximating to this: the simplest is a sufficiently high voltage source in series with a sufficiently high resistance, while in more sophisticated versions the high slope resistance at a pentode anode or a transistor collector can offer the wanted approximation with economy

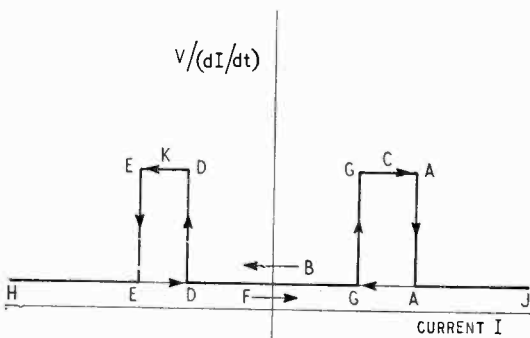

Fig. 2. Measured properties of two-terminal device with current drive.

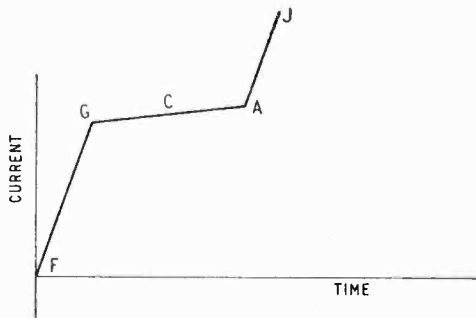

Fig. 4. Measured properties of two-terminal device with voltage drive.

of voltage. I do not think we need to explore the details of a suitable circuit here.

We set the current at a substantial negative value, corresponding to the point H and then increase it. "Increase" is used here in a strictly formal way to mean that dI/dt is positive: numerically the current shown on a meter, which is $|I|$, will fall to zero and then rise in the opposite direction. We measure the voltage across the terminals and we also measure, or fix in advance, the rate of change of current with time. Let us assume that we have arranged matters so that dI/dt is constant. Then, equally, as we allow (and what else can we do, indeed) the passage of time, H increases steadily, with dH/dt also constant. (Again, since dH/dt is positive, I use "increase".) From H through E, F to G we have dB/dt which is constant and small, so that we observe a small and constant voltage across the terminals. At G there is a sudden change. As we go along G, C to A the terminals voltage becomes very high but at A, and as we progress towards J it drops again. The voltages we observe are proportional to dB/dt , and thus proportional to dI/dt . We can therefore plot the diagram of Fig. 2. This may be more familiar to some readers in the form shown in Fig. 3 which takes account of the fact that to traverse the system from right to left we must have dI/dt negative and we shall therefore observe a negative voltage across the terminals. This effect is slightly obscured in Fig. 2.

In a second experiment we apply a constant voltage to the terminals and observe the current. We shall assume that initially we are at the point F of Fig. 1. As we have already said, the rate of change of magnetic flux is proportional to voltage and since the voltage is constant the flux must be changing at a constant rate. The projection of the working point on the B axis moves steadily upwards. There is a rapid transition from F to G, associated with a rapid rise in current but then as we move along G, C to A the current changes very little. Once A is reached only a short time is occupied by the run along AJ towards unlimited current. This is the pattern shown in Fig. 4.

The important feature of the current-time characteristic at constant voltage is the plateau GCA. Since we have $V = NA \cdot 10^{-8} dB/dt$ and V is constant we can integrate this very easily to get

$$Vt = NA \cdot 10^{-8} (B_1 - B_0)$$

where B_1 and B_0 are the values of flux corresponding to the points A and G respectively. $(B_1 - B_0)$ is equal

to the spacing between points B and F, or twice the remanent flux B_r . A coil of N turns of area A on a material having a remanent flux B_r has therefore a characteristic

$$2NAB_r 10^{-8} \text{ volts-seconds.}$$

It may be useful to notice the sort of values to be expected. A coil of 1,000 turns will give volts-seconds products in the region of 1-10 volt milliseconds while draining away only milliamperes. Thus such a coil might take an almost constant current of a few milliamperes for perhaps 10 milliseconds and then allow some hundreds of milliamperes to flow. With only a few turns the characteristic will be a few volts-microseconds and the current required to reach the point G will be some hundreds of milliamperes.

For many practical applications we do not operate with ideal voltage or current sources but with sources of finite (which means in practice comparable with the load) impedance. Let us consider a source of voltage V_0 and resistance R_0 . Now in Fig. 4 the step from F to G is very short and we can therefore get a quick picture of the sequence of events by assuming that there is somehow a jump to a constant current I_0 which is the value for the whole GCA plateau. When the generator is first connected the full voltage V_0 appears across the coil but as soon as the current I_0 is established the voltage across the coil falls to $(V_0 - I_0 R)$. This value remains constant for a time $(2NAB_r \cdot 10^{-8}) / (V_0 - I_0 R)$ and then the current through the coil increases rapidly and, if the coil resistance can be neglected the current rises to V_0/R and the voltage drop across the coil is zero. This is shown in Fig. 5. The idealized characteristic shown in Fig. 5(b) can be turned into a closer approximation by replacing the three linear segments by the exponential which would be calculated using the appropriate values of inductance, defined in terms of the value of dB/dH for the corresponding segment.

It is this property of square-loop materials which has led to their widespread use in transistor square-wave oscillators which are now becoming popular as inverters for producing an a.c. supply from a battery source and, by extension, producing high

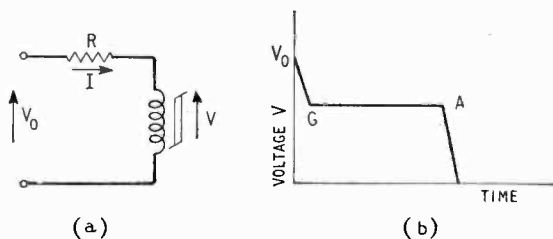

Fig. 5. The voltage with a finite source resistance.

voltages by the subsequent transformation and rectification. In these circuits the duration of each half-cycle is fixed by the plateau A Fig. 5(b). Another way of looking at these circuits is to consider them to be LR multivibrators, with a very large inductance corresponding to the steep slope of GCA in Fig. 1. The half-cycle time, which depends upon L/R has barely begun, and the characteristic sag is only just discernible, when the core reaches its limit at A. The inductance changes to a very small

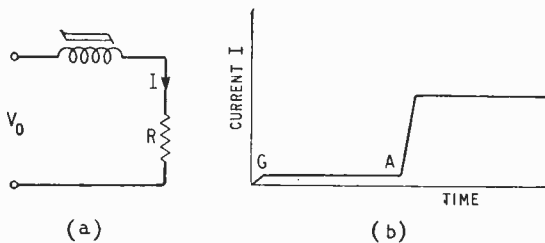

Fig. 6. The current into a finite resistance fed from a fixed voltage through a saturable choke.

value and the remainder of the half-cycle is performed with a very small L/R value.

Another application is, of course, the memory core. We have seen that with no current applied we must be at B or F, depending on whether the last active point was J or H. Suppose we are at B. A current pulse, with positive current, will run up the track BAJ. The change of flux will not be very great so that the voltage generated in a winding on the core, which depends on dB/dt , will be small. But if the last state were F, this current pulse would traverse the path FGCAJAB and we can see from Fig. 2 or Fig. 3 a substantial voltage pulse would be produced. By setting the core to either B or F we can thus "write in" one bit of information, a yes or no, a 1 or 0, and can extract it at our leisure. Moreover, since a current, or more exactly ampere-turns, which does not carry us to G will not affect the setting at F but will let the core fall back again we can use several windings which must be simultaneously pulled to bring the information out. It is in structures of this kind that we encounter the cores switched in times measured in microseconds, perhaps using only single turns.

The memory cores are perhaps a couple of millimetres in diameter, the inverter cores the size familiar in ordinary low-frequency amplifier design. In yet another application, magnetic amplifiers, which find application in a wide field from aircraft

controls to the regulation of the supplies to large furnaces, the sizes range upwards from a few ounces into the hundredweights. Fig. 6 is merely a rearrangement of Fig. 5 with attention focused on the current through the resistor R. It will be seen that until A is reached there is only a small current in the load resistor. Suppose, then, that just as we reach A we reverse the voltage: we shall then traverse the path ABDKE with a similar, but oppositely sensed, current. At E we again reverse the voltage and this alternating voltage drives only a small alternating current through the load. Now let us, by means of another winding carrying a steady current, bring the starting point to C. To move from C to A under the influence of V_0 takes only one-half the time for the movement from G to A and so for the remainder of the time before the reversal the full current of V_0/R will flow in the load.

Having regard to the space I have already filled I do not propose to describe how the core is reset and how this second winding is disposed of so that, in fact, by the use of several windings on separate lines, it is protected from having excessive voltages induced in it. These matters of ingenuity are used to make practicable the magnetic amplifiers in which relatively small control currents affect the discharge of large powers into the loads by altering the fraction of a cycle during which the current is free to flow.

I had hoped that at some point in this study the idea of inductance would have forced itself in. It has not done so except as a means for improving some of the approximations and even then I am sure we could have managed without it. In its place we find a factor which has no name but which we might call endurance, the volts-seconds product before collapse. This is a very real characteristic of a square-loop cored coil and a much less sharply defined characteristic of a coil with a silicon iron core or with a small air-gap. It is a characteristic to which I fear we must all become accustomed. But how I wish it had a name.

SHORT-WAVE CONDITIONS

Prediction for April

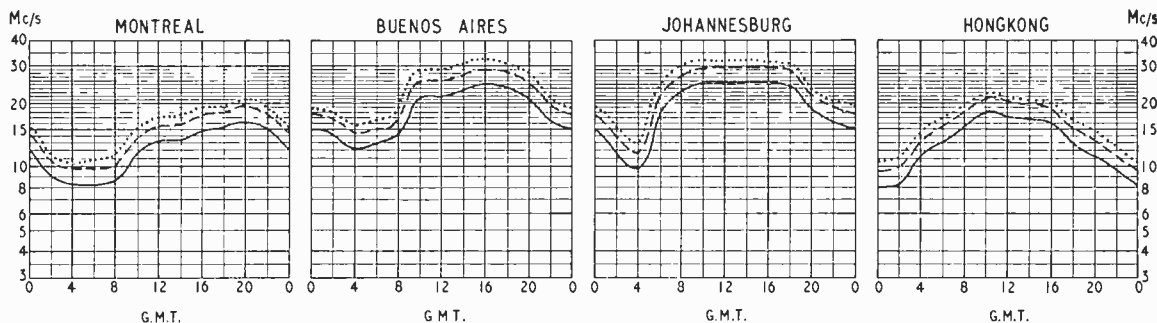

THE full-line curves indicate the highest frequencies likely to be usable at any time of the day or night for reliable communications over four long-distance paths from this country during April.

Broken-line curves give the highest frequencies that will sustain a partial service throughout the same period.

- FREQUENCY BELOW WHICH COMMUNICATION SHOULD BE POSSIBLE FOR 25% OF THE TOTAL TIME
- — — PREDICTED MEDIAN STANDARD MAXIMUM USABLE FREQUENCY
- FREQUENCY BELOW WHICH COMMUNICATION SHOULD BE POSSIBLE ON ALL UNDISTURBED DAYS

Multivibrator Design

USE OF CONSTANT-CURRENT PRINCIPLE

By R. C. FOSS, B.Sc., Grad.I.E.E., and M. F. SIZMUR, B.Sc.

AN engineer designing electronic circuits has a number of special problems which are not commonly met in other branches of engineering. One such problem arises from the use of valves and transistors, which have unavoidably wide tolerances on their characteristics. Steam engines manufactured with a tolerance of $\pm 50\%$ on piston diameter would hardly be expected to perform well or even work at all! However, it is often necessary to make electronic circuits perform reliably with tolerances of this order on transistor parameters. Evidently to achieve this aim, the performance of the circuit must be made as far as possible independent of the precise values of such parameters. The designer must use techniques which ensure that the behaviour of the circuit depends upon those components whose values are

if an optimum design is achieved at the first attempt, and it is impossible to tell how far away from the optimum the design is without experimental investigation. Lastly, the lack of a quantitative understanding of the way in which the circuit works may well complicate maintenance because of the difficulty in deciding whether it is operating correctly or not.

These difficulties may all be avoided if circuits can be designed which are not critical as to the precise values of valve or transistor parameters and whose behaviour is determined by the values of passive components. Experience shows that the design procedures for such circuits are often quite simple; the amount of effort needed may be reduced to little more than an exercise in Ohm's Law and the solution of the transient response of an R-C circuit!

The way to achieve this state of affairs is to use the valve or transistor as a switch with "on" and "off" states determined by passive components, the transition between states being governed by R-C timing circuits. The characteristics of the active element are thus involved only in the transition from one state to the other.

Because the multivibrator is one of the most useful and most widely known of waveform-generating circuits, it has been taken as an example to illustrate these techniques. Fig. 1 shows the Abraham and Bloch multivibrator circuit. Neglecting the time taken for change of state, the periodic time for this arrangement is the sum of the "off" periods for both valves. Fig. 2 shows the exponential waveform appearing on each grid in turn during its "off" period, E_0 being the initial value, E_1 the value at which the circuit changes state and T the circuit time constant. If the "off" period, t_1 , is to be accurately specified, it is necessary to fix E_0 and E_1 or at least the ratio of these voltages.

The appendix describes a simple method of finding

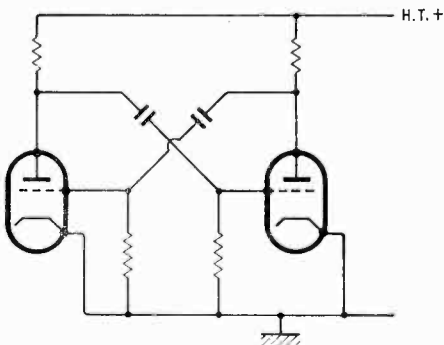

Fig. 1. Abraham and Bloch multivibrator circuit.

under his control, such as capacitors, resistors and inductors.

Because it is a comparatively easy task to assemble and modify a prototype, there is often a strong temptation to "design" circuits by cut and try methods. This temptation should be resisted as this method has numerous drawbacks. First, there is no reason why the performance of a circuit arrived at by cut and try should be governed by the values of passive components and not depend critically upon valve or transistor parameters. The circuit may have this desirable property but most likely it will not. The second drawback is that the circuit can only be developed into a form suitable for production by an experimental investigation in which the effects of all tolerance changes are explored in a systematic manner. This may well turn out to be a lengthy process and there is always the possibility that at some late stage the circuit may be found unsuitable for production, necessitating a fresh start. Another drawback is that it will be purely fortuitous

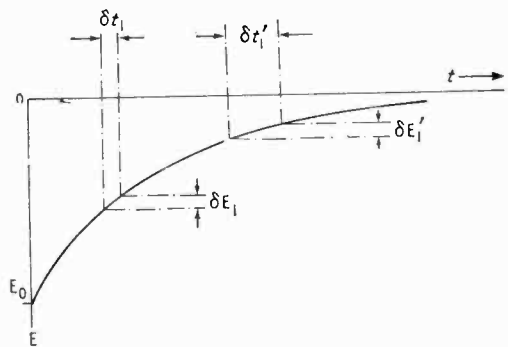

Fig. 2. Exponential waveform appearing in turn at each grid in Fig. 1 during its "off" period.

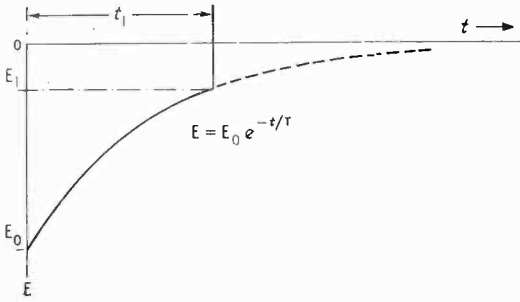

Fig. 3. Illustration of the important design point that E_1 should not be made too small relative to E_0 so that a small change in E_1 does not produce too large a change in t_1 .

t_1 in terms of this ratio and the circuit time constant.

It should be noted that if E_1 is made small with respect to E_0 , then small changes in the value of E_1 will produce disproportionately large changes in t_1 and hence in the periodic time of the circuit. Fig. 3 illustrates this point and it should be emphasized that this is most important in practice when E_1 is dependent on valve or transistor characteristics.

The basic multivibrator of Fig. 1 is not a "designable" circuit as it stands because the "on" state of the triode valve is made dependent on its characteristics, including the grid current/grid voltage relationship. Thus the change in anode potential between cut-off and cut-on and therefore the output amplitude and the starting point of the grid timing exponential are poorly defined. Furthermore, in this particular circuit the value of grid voltage, E_1 , at which the transition occurs is small compared with the initial value, E_0 , and is likely to change as the valves age or are replaced.

It has been shown by Williams (Ref. 1) that these unsound features of the circuit can be avoided by the use of "bottoming" pentodes to give a well-defined anode swing, and by returning the grid leaks to the h.t. positive rail to make changes in the effective grid base have little effect.

The circuit known as the long-tailed pair (Ref. 2) can be used to achieve equal ease and soundness of design in a wide range of waveform circuits, while retaining the economic advantage of the triode, particularly the double triode. Although circuits employing feedback in a common-cathode resistor are fairly well known, it does not seem to be so well appreciated that it is possible to use this resistor to largely define the total cathode current, or "tail current" of the pair. The tail current in the circuit of Fig. 4 is given by:—

$$I_T = \frac{E_T + v_k}{R_T} \dots \dots (1)$$

where the cathode voltage v_k is determined by the values of v_{g1} , v_{g2} , and the valve bias. Provided that these quantities, and changes in them, are made appreciably less than the fixed "tail voltage" E_T , say up to 20% of E_T , it will often be possible to take the tail current as constant.

$$I_T \approx \frac{E_T}{R_T} \dots \dots (2)$$

For waveform-generating circuits, this current is normally arranged to flow entirely in one or other of the pair, and this current is switched from one to the other by a differential voltage applied to the grids. To estimate the value of differential grid voltage necessary to produce this switching action, suppose that the valve characteristics of each of the pair are identical. Suppose also that a value of grid-cathode bias $-e_b$ is necessary for the valve to draw current I_T , and that a value $-e_c$ just cuts off the valve. As changes in anode voltage are not normally large, the effective grid base, defined as $(e_c - e_b)$, may be assumed constant. Considering again the circuit of Fig. 4; if v_{g1} is made zero and v_{g2} very negative, V2 will be cut off, and V1 will be conducting. By the assumption, the cathode potential is $+e_b$. If v_{g2} is now allowed to rise, then when it passes a value $-e_c$ relative to the common cathode, that is $-(e_c - e_b)$ relative to earth, V2 starts to conduct. With v_{g2} continuing to rise the cathode voltage increases until it reaches a value $+e_c$ when V1 will be completely cut off. The value of v_{g2} at this point is $(e_c - e_b)$, and it is seen that a differential change in grid voltage of two effective grid bases is required to switch I_T . This thermionic equivalent of the two-way switch has been very successfully used in the design of digital computers (Ref. 3).

The multivibrator about to be described, due originally to E. L. C. White (Ref. 4), can be thought of as just such a switch actuated by positive feedback through a timing network from one anode to the opposite grid (see Fig. 5). With this circuit the free-running repetition rate is not well-defined, since it is very dependent upon the valve cut-off bias as shown in Fig. 3. However, this is an excellent circuit for use where a square wave synchronized to an external waveform is required. As it is the differential grid voltage which actuates the "switch", the synchronizing waveform is applied to the "free" grid (with acknowledgements to a well-known contributor to *Wireless World!*). This grid takes no part in the regenerative action, so it will not inject any signal back into the synchronizing circuit.

The anode of V2 also plays no part in the regenerative action, and from this anode an output can be taken without affecting the operation of the circuit, a feature which may eliminate the necessity for a buffer stage.

To analyse the operation of the circuit, a few

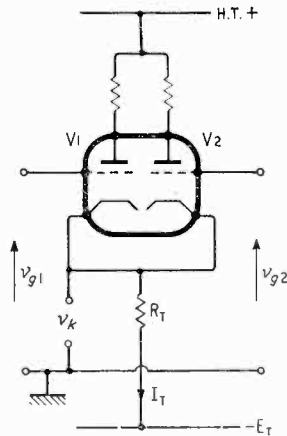

Fig. 4. Long-tailed pair circuit.

additional assumptions will be helpful. These are:—

- (i) That R_3 is large relative to R_1 so that the grid circuit loading on the anode of V1 may be neglected.
- (ii) That stray capacitances may be neglected.
- (iii) That neither valve is forced to draw grid current.
- (iv) The circuit is free-running, the grid of V1 being at earth potential.

To begin the analysis, suppose that I_T has just started to flow through V1, the valve having previously been cut off. The fall in anode voltage, $E = I_T R_1$, will have been coupled to the grid of V2 by the capacitor C, as shown in the waveform diagram Fig. 6. This fall cuts off V2 and drives the current into V1 as postulated. C will now discharge through R_3 and R_1 and the grid voltage waveform will be an exponential rise towards earth. Meanwhile the cathode is at e_b , held by the grid of V1. When the grid of V2 reaches a point one effective grid base below earth, V2 can start to conduct just as was considered in the case of the circuit of Fig. 4. The current in V1 falls and this rapidly turns V2 on and V1 completely off, transmitting a positive swing of E to the grid of V2. The cathode follows this rise, and also the ensuing fall towards earth. Finally, when the grid has reached a point one effective grid base above earth, V1 can start to conduct and the cycle recommences.

From the analysis, it can be seen that the mark and space times are equal, and are governed by an exponential curve from $E - (e_c - e_b)$ to $(e_c - e_b)$, relative to earth, on a time constant of CR_3 seconds approximately. The free-running period can thus be estimated using log tables, or graphically as shown in the appendix.

Some practical design points arising from the assumptions made for the analysis can now be considered.

The designer must ensure that neither valve is forced to draw grid current. In the case of V2 this would alter the effective time constant in an unpredictable way on one half cycle only, giving unequal mark and space times. The most critical instant in the cycle is t_1 , Fig. 6, when the anode-to-cathode voltage of V2 has its minimum value. This must be sufficient to enable the valve to pass current I_T with negative grid bias.

During the transitions R_3 is effectively in parallel with R_1 , and if R_3 is made comparable with R_1 , the anode and grid swings will be reduced to $I_T R_1 R_3 / (R_1 + R_3)$. Also the time constant of the exponential grid voltage should be taken as $C(R_1 + R_3)$.

Stray capacitances cannot be neglected in practice. At an anode, stray capacitance C_a will turn the theoretically instantaneous rise and fall into exponentials of time constant C_a times the anode load. The effect of stray capacitance at the grid of V2 will depend upon the value chosen for the coupling capacitor C. Should the two be comparable then only an unknown proportion of the anode swing appears at the grid of V2.

To show how easy the design procedure is in practice, suppose a synchronized multivibrator is required, using a 12AT7 valve to give two antiphase outputs of 100 volts. Although the design would be easier if a negative supply were available for the "tail", it will be assumed that only a 300 volts supply is available. Of this 300 volts, 100 are used

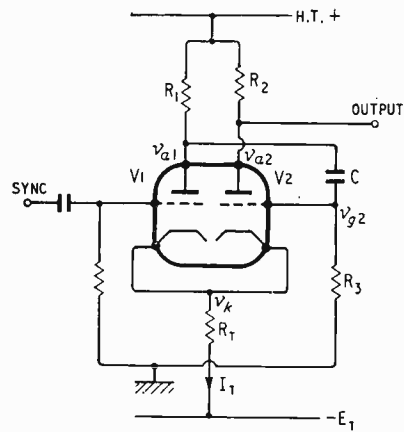

Fig. 5. White's multivibrator circuit.

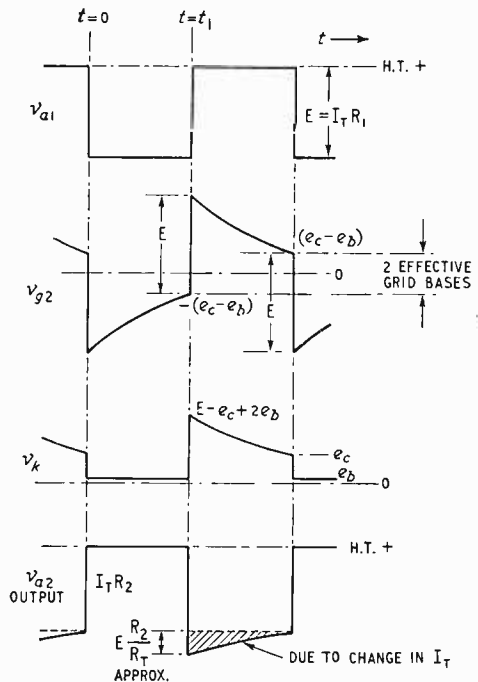

Fig. 6. Waveforms appearing at various points in the multivibrator circuit of Fig. 5.

for the tail. This leaves only 100 volts for the conducting valve, and to avoid driving it into grid current, a small value of tail current, 2mA, is chosen, making $R_T = 47$ kilohms. For two 100 volt outputs, both anode loads are 47 kilohms also. If the whole 100-volt swing is coupled to the grid of V2, the assumption of constant I_T will fail miserably, and V2 will be left with no anode voltage. The circuit of Fig. 7 shows how this is overcome by transferring only 20 volts of the swing. The approximate free-running half-period will be governed by (20-4) volts decaying to 4 volts, the effective grid base. As shown in the appendix, this decay to 0.25 of the initial value takes $1.4CR_3$ seconds, CR_3 being the

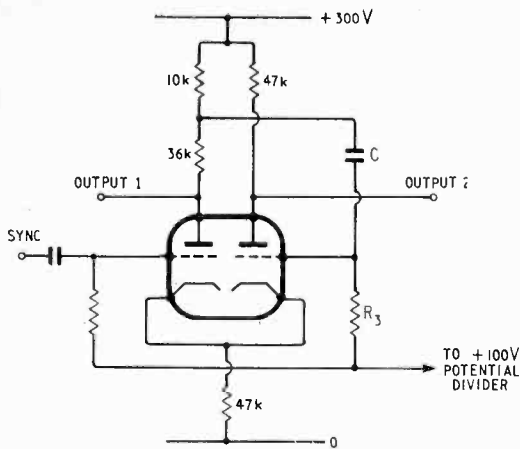

Fig. 7. Illustrative multivibrator design.

time constant. Finally the rise and fall times with $C_s = 20\text{pF}$ at each anode will be about $3\mu\text{sec}$, with anode time constants of $1\mu\text{sec}$. This figure compares favourably with the rise time obtainable from a circuit of the type shown in Fig. 1; at a repetition frequency of 500 c/s values of the order of $100\mu\text{sec}$ are more typical.

For many purposes, the measured performance of the circuit will correspond sufficiently closely to these design figures. The negative swing at the anode of V2 is about 20% greater than 100 volts due to the increase in I_p at time t_1 in Fig. 6. The only other major discrepancy likely to arise is in the free-running half-period, as this depends on the grid base as previously mentioned.

In the concluding part of this article, a similar circuit will be described in which the free-running period of oscillation can be defined to within a few per cent, the circuit being particularly suitable for use with transistors.

APPENDIX

Graphical Solution of the Exponential Equation.

The solution to expressions of the form

$$E_1 = E_0 e^{-t/T}$$

where E_0 and E_1 are known, and it is required to find t in terms of the time constant T , can be obtained by taking logs or by log-log slide-rule scales. A quick alternative method, which is usually sufficiently accurate, is to use a graph of the function $e^{-t/T}$

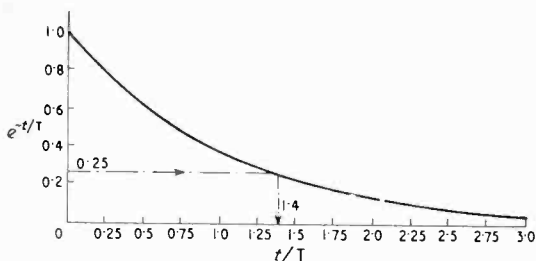

Fig. 8. Graph of $\exp(-t/T)$ plotted against t/T .

plotted against t/T , Fig. 8. Taking the example of a decay from 16 volts to 4 volts, that is $E_1/E_0 = 0.25$, this corresponds to a time of 1.4 T . Because this graph is, in effect, a scale drawing of the circuit waveshape, gross errors in calculation are unlikely and the effects of small changes of E_1 on the timing of a circuit are more easily seen.

REFERENCES

- Ref. 1. Williams, F. C., "Introduction to Circuit Techniques for Radiolocation", *J.I.E.E.* 1946, Vol. 93, IIIA, p.289.
- Ref. 2. Blumlein, A. D., British Patent No. 482,740 (1938).
- Ref. 3. Newman, E. A., Clayden, D. O., Wright, M. H., "The Mercury-Delay-Line Storage System of the ACE Pilot Model Electronic Computer", *Proc. I.E.E.*, 1953, Vol. 100, Pt. 11, p.445.
- Ref. 4. White, E. L. C., British Patent No. 535,778 (1941).

Commercial Literature

Sheet Insulation may be adversely affected by discharges taking place on or near its surface. Eight plastics materials and silicone rubber, Perspex and synthetic-resin-bonded laminates have been tested for the resistance to surface discharges by the Electrical Research Association Laboratory. Copies of the 42-page report entitled "The Resistance of Sheet Insulation to Surface Discharges" by J. H. Mason may be obtained from Publication Sales Department, Electrical Research Association, Thorncroft Manor, Dorking Road, Leatherhead, Surrey. Price 15s or 15s 8d by post.

Semiconductor Rectifiers.—Quick selection of G.E.C. silicon and germanium rectifiers in six basic circuit arrangements up to 400-V 100-A output is possible with rotary chart from G.E.C., Semiconductor Division, School Street, Hazel Grove, Stockport, Cheshire.

Transistor Converters for changing low-voltage d.c. supplies into high-voltage a.c. or d.c. are made in both hermetically-sealed and open constructions by Transipack. Information on converters from 2W to 1kW rating from Transipack, 29 Burnt Ash Hill, London, S.E.12.

Demonstration Servo System made by Feedback Ltd., of Crowborough, Sussex, uses part "bread-board," part unit construction to make clear the functioning of d.c. closed- and open-loop position control. The front panel of the control unit carries a simplified diagram fitted with terminals for interconnecting links.

Resistors, Capacitors and Inductors having glass dielectrics and insulators are among the many devices using special glasses made by Corning Glass Works. Glass construction makes possible employment of components under adverse working conditions: for instance, very high levels of nuclear radiation have little effect. Loose-leaf catalogue containing data sheets on components and subassemblies from Corning Glass Works, Bradford, PA (U.S.A.) or James A. Jobling, Wear Glass Works, Sunderland.

Measurement Accuracy of 0.05% is achieved in the Muirhead Wigan D-930-A precision r.m.s. decade voltmeter. This accuracy is achieved over the greater part of the range of 1mV to 300V and 5c/s to 100kc/s. Weston cells are used for standardization. Publication No. 150 from Muirhead & Co. Ltd., Beckenham, Kent.

Plastics Diaphragm resistant to deterioration at high temperatures enables the S.T.C. Type 4105 moving-coil cardioid microphone to be used under adverse conditions, such as amid the footlights in a theatre. Total harmonic distortion is of the order of $\frac{1}{2}$ to 1% at intensity levels approaching the threshold of pain. Leaflet describing the Type 4105 and "An Introduction to Microphones" (pamphlet giving general advice on choice of type) from Public Address Department, Standard Telephones and Cables Ltd., Connaught House, 63 Aldwych, London, W.C.2.

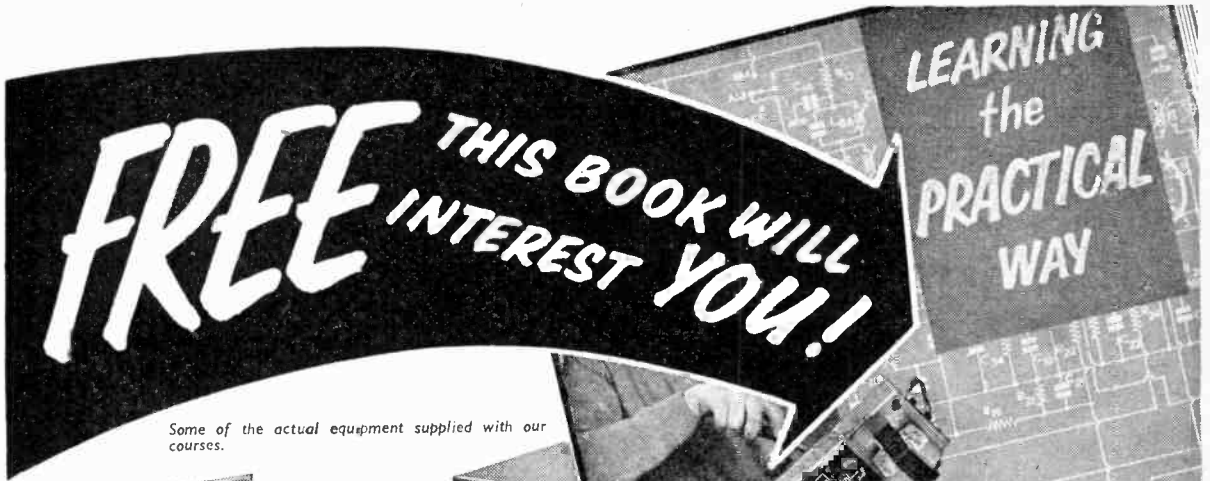

Some of the actual equipment supplied with our courses.

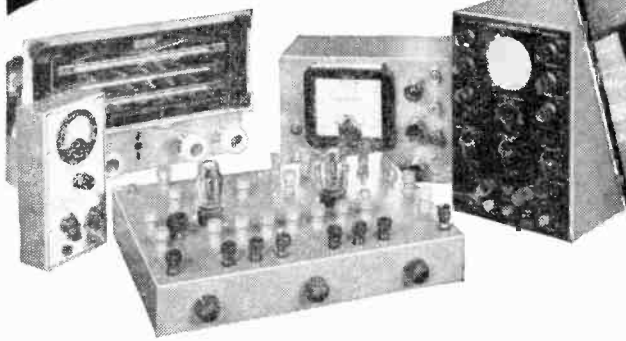

A NEW-PRACTICAL WAY of UNDERSTANDING

RADIO · TELEVISION · ELECTRONICS

Including: Transistors; VHF/FM; Hi-Fi equipment; Computers; Servo-mechs; Test Instruments; Photo-electrics; Nucleonics; etc.

FOR ... Your Career ... Your Own Business ... An Absorbing Hobby ...

Radiostructor—an organisation *specialising* in electronic training systems—offers a new self-instructional method using specially designed equipment on a “do-it-yourself” basis.

You learn by building actual equipment with the big kits of components which we send you. You advance by simple steps, performing a whole series of interesting and instructive experiments — with no complicated mathematics! Instructional manuals employ the latest techniques for showing the full story of electronics in a practical and interesting way—in fact, you really have fun whilst learning!

Fill in the coupon below, for full particulars:—

RADIOSTRUCTOR

LEADS THE WORLD

IN ELECTRONICS TRAINING

POST NOW

To RADIOSTRUCTOR (Dept. G66),
READING, BERKS.

Please send brochure, without obligation, to:—

* Name

Address

*BLOCK CAPITALS PLEASE

(We do not employ representatives)

4.61

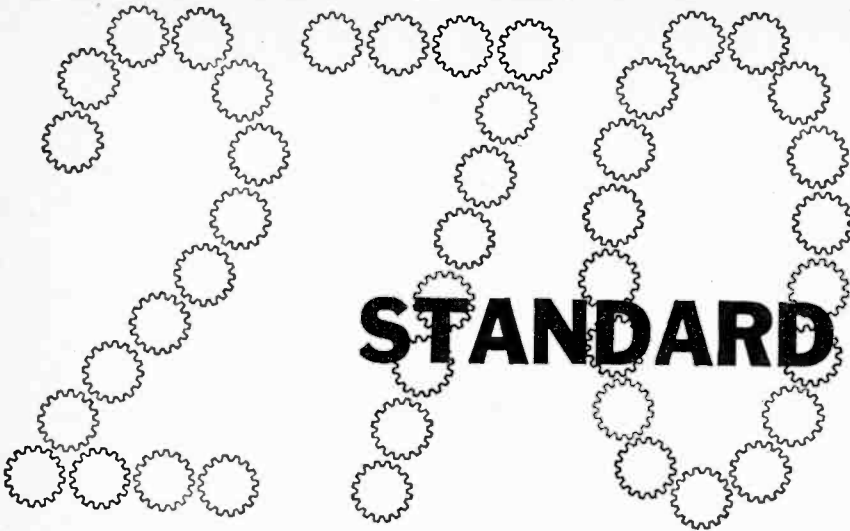

STANDARD SPEEDS

*from 57 mins. per rev.
to 2,700 revs. per min.*

Type RQR

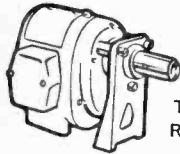

Type RQ 53

Type RQH

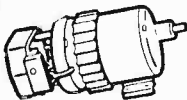

Type RQU



Type RQG

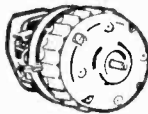

No other motors offer the wide range of speeds, torques and programme switching of the versatile Drayton RQ. Conforming to BSS 170/1939, it is suitable for continuous or intermittent running; reversing; and can also be supplied with or without internal limit and programme switches. Motors giving a shaft rotation of more than one revolution before switching operates, or with multi-position switching, are also available. Write now for your copy of Data Sheet No. 302.

DRAYTON 'RQ' MOTORS

THE DRAYTON REGULATOR & INSTRUMENT CO. LTD
West Drayton, Middlesex Phone: West Drayton 4012

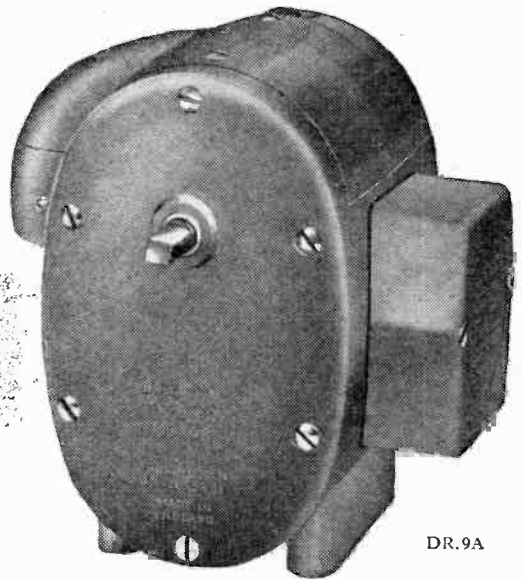

DR.9A

Negative Feedback and Non-Linearity

By "CATHODE RAY"

IT is commonly believed that negative feedback reduces undesirable things, such as distortion, to the same extent as it reduces amplification. This belief is not without some foundation, but like many others it is an over-simplification and ought not to be applied indiscriminately.

For instance, one of the undesirable things (in a.c.-driven equipment) is hum. So far from invariably reducing it in the same ratio as amplification, negative feedback sometimes reduces it less than that, or not at all, or even considerably increases it.* Another of the undesirable things is the random noise we were considering only a month or two ago. It is certainly possible to reduce such noise by negative feedback, but, since the wanted signals are likewise reduced, the signal-to-noise ratio (which is what matters) is in no way improved. Increasing the overall amplification to make good the loss due to feedback increases the noise too.

By this time some may be beginning to wonder what advantage negative feedback ever does give. What about distortion? Might not the necessary extra amplification re-introduce it and leave one no better off?

Well, of course, there are several different kinds of distortion, and one can't cover them all at once with a simple Yes or No. There is non-linearity, which alters the shape of even a single pure sine-wave signal. This it can be regarded as doing by introducing signal frequencies that were not present in the original. Then there is amplitude/frequency distortion, which alters the shape of signals only when they include more than one frequency, and upsets the balance of tone in sound programmes. Phase distortion makes no perceptible difference to sound, but it alters the shape of multiple-frequency signals, so it affects the appearance of television pictures.

Reducing non-linearity is usually the main object of negative feedback, because that is the most unpleasant form of distortion where sound is concerned. No amplifier with any claim to be suitable for high-quality reproduction would be without negative feedback. So presumably it does do some good. The question is whether it does as much good as is commonly believed.

Readers who were born, so to speak, with Nyquist diagrams on their bibs, and who are merely following my plough on the off-chance of its unearthing some stray fragment of novelty, must be prepared to show forbearance while for the next few paragraphs I recapitulate the basic principles of negative feedback for their juniors in the art.

The box in Fig. 1(a) represents an amplifier; its voltage amplification or gain is customarily denoted by A, which means that for every signal volt (or millivolt, more likely) applied between the input

terminals it gives A volts (etc.) between the output terminals.

If now we take some fraction B of this output voltage and introduce it in series with the input voltage, as at (b), the gain of the amplifier, reckoned between its own two pairs of terminals, is still A. But for practical purposes the feedback connection becomes part of the amplifier, so the input terminals become those marked XX. The net gain between them and the output terminals is called A'. If we try to calculate A' in terms of A and B by supposing (for simplicity) that the signal source delivers 1 volt to the new input terminals, we get stuck. The thing to do is to work from the fact that 1 volt at the old input terminals gives A volts at the output. The voltage fed back is then AB.

Now this is where we have to be careful about signs. *Negative* feedback, represented by a negative value of AB, is defined as feedback that opposes the input voltage to XX, requiring it to be greater than 1 volt in order to maintain the 1 volt at the input to the amplifier itself. A positive value of AB therefore means an XX input less than 1. So in either case it must be $1 - AB$ volts. The corresponding output being A volts, the overall gain is

$$A' = \frac{\text{output}}{\text{input}} = \frac{A}{1 - AB}$$

This is the "Ohm's law" or ABC of feedback.

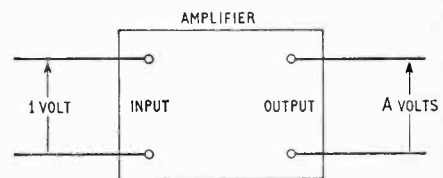

(a)

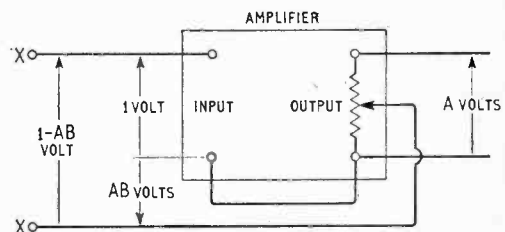

(b)

Fig. 1 (a) represents an amplifier without feedback, and (b) the same amplifier with feedback, a fraction B of the output voltage being tapped off and returned to the input. The arrows show the relative polarities for positive values of all instantaneous voltages. If the feedback is negative, the minus sign in $1 - AB$ is cancelled out.

*My last treatise on this was 15 years ago, and as it is unlikely that many readers present ever saw it or could remember it if they did, a return to the subject may be nearly due.

Although for simplicity we assumed 1 volt at the original or internal input, the above result would have been just the same if it had been any other amount, say V .

One of the first things usually pointed out about this equation is that if the negative voltage fed back is made much larger than the internal input, an approximate formula for A' can be obtained by neglecting the relatively small 1 in the denominator, the result being

$$A' = \frac{1}{-B}$$

which means that the overall gain is almost independent of the internal gain, A , and is decided mainly by B . In other words, ample quantities of negative feedback prevent the gain of an amplifier from being much affected by the usual uncertainties such as ageing valves and fluctuating supply voltages.

By the way, newcomers may have been wondering why we take the trouble to put a minus in these formulae, only to cancel it with another minus by making the feedback negative. Why not define AB as the *negative* voltage fed back, making the denominator $1 + AB$? That would be quite sensible if in a negative-feedback amplifier the feedback were always negative, but in all but the simplest circuits (such as cathode followers) there are some frequencies at which a 180° phase shift makes the feedback positive, and the risk of confusion might be even greater if we decided to denote this by a negative value of AB . Nevertheless, it is sometimes done (in case Mr. D. L. Clay is reading this, I hasten to point out that I did it myself in Feb. 1946) so one must be prepared for either.

The recapitulation is now over and those who were dozing off may wake up. We were saying that the belief that negative feedback reduces non-linearity distortion in the same ratio as it

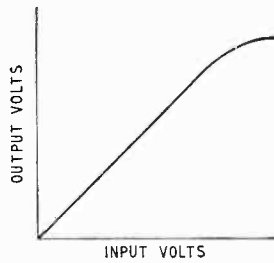

Fig. 3. This is one kind of output/input graph, in which the voltages are peak or r.m.s. values.

reduces the gain of an amplifier may need to be looked at again.

The basis for the belief can be explained simply as follows. Suppose we still have our 1 volt of signal at the input of the amplifier itself, yielding A volts of signal at the output. But owing to non-linearity the amplifier generates harmonics and intermodulation products. Suppose the amplitude of any or all of these, relative to the signal output, is p . Then the distortion output (without feedback) is pA volts. This can be regarded as due to a distortion signal $1A/p$ as large (i.e., p volts) at the input, but to make clear that this is an internal signal, not applied from without, it can be shown as in Fig. 2(a), which takes account of distortion only. The corresponding state of affairs with feedback is shown at (b), and as we don't know how much distortion is emerging we call it x volts. The voltage fed back is of course Bx , so the total input is $Bx + p$. When multiplied by the gain of the amplifier, A , this must amount to x :

$$A(Bx + p) = x$$

$$Ap = x(1 - AB)$$

$$\frac{x}{Ap} = \frac{1}{1 - AB} = \frac{A'}{A}$$

proving that feedback affects the amount of distortion emerging from the amplifier in the same ratio as it affects the overall gain of the amplifier.

In this calculation we quietly assumed that the signal output (not shown) was the same in both (a) and (b), for that is what determines the amount of distortion generated internally, as is represented in both diagrams by the same " p volts." This means that the input (to XX) must have been increased to the same extent as the internal gain was reduced by negative feedback. And of course that *could* cause serious distortion in the pre-amplifier. But even with the increased signal level at XX it is generally easy to keep it negligible. However, if the use of feedback raises the level there so much that it is not easy, the feedback should be taken to an earlier stage, or A increased with perhaps a reduction in B . That is all part of routine feedback technique.

The basis of belief having been proved, we may think we can all go home. But actually this is just where we begin. For a start, what precisely do we mean by A ? We defined it—or, to be quite fair to you, I defined it—as the number of signal volts received at the output for every volt applied at the input. (To silence any objectors who might claim that even 1 volt at the input of their amplifier would hopelessly overload it, I offered a choice of millivolts, or indeed any appropriate unit.) Nothing was said about the sort of volts—peak, r.m.s. or

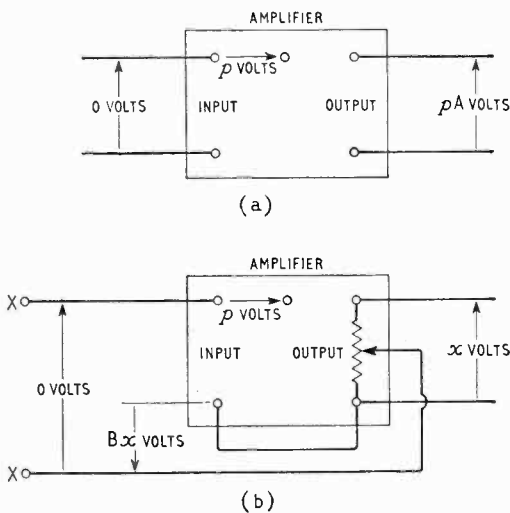

Fig. 2. These diagrams correspond to Fig. 1, with the same signal voltages present but not shown. Instead, the voltages shown refer to distortion products created by the non-linearity of the amplifier at that particular signal level. They enable the apparent reduction of distortion by feedback to be calculated.

instantaneous—but whatever was in mind it must have been assumed that A was constant, not depending on the signal voltage, at least within the working limits of the amplifier. In other words, it was assumed that the amplifier was linear. That being so, it wasn't very clever to use it in a calculation concerning amplifier non-linearity. We did, of course, guard against complete absurdity by stipulating that the signal voltage must be the same in both diagrams in Fig. 2. But if the non-linearity is considerable, so that the distortion is a substantial part of the total output, that safeguard isn't good enough. For, if feedback has any effect on the amount of distortion, the total output will be different and A will almost certainly be different.

So much for the general principle. The belief is undermined. The next thing is to see how it might work out in practice. The correct procedure, of course, would be to embark on a comprehensive and rigorous mathematical analysis that would cover every case (for those who could see the wood for the trees). But you know me too well to expect that.

The "line" in "linearity" is the graph of output against input. There are two sorts of these graphs: one could be plotted by connecting a calibrated a.f. signal generator to the input of the amplifier and varying the signal strength there while measuring the corresponding r.m.s. or peak voltages at the output. The curve might look something like Fig. 3. There would be no point in reversing the connections with the idea of extending the curve into the negative

region, for its shape would necessarily be the same in reverse. The other kind, which is the one we are going to study, is to be seen by substituting the Y plates of a cathode-ray oscilloscope for the output voltmeter, and connecting the X plates (with suitable distortionless amplification) across the input. The positive and negative half-cycles obviously swing the curve in both directions from the origin as their instantaneous values are shown on the screen, and their shapes are not necessarily the same.

A perfectly linear amplifier would yield a perfectly straight "curve," as in Fig. 4(a). In the case of a power amplifier this would merely show that it was being uneconomically under-driven. In a commercial world it is necessary to work up to some distortion, even though it be limited to as little as 0.1%. Most amplifiers, so long as they are not over-driven, tend to show curves of two main shapes (or combinations of both), as in Fig. 4(b) and (c). The first has a square-law term in its output/input equation, which generates a second harmonic of the signal, and second-order intermodulation. The second has a cubic term and generates third-order distortion, which sounds worse.

Now A (being output/input) is represented on these Fig. 4 diagrams by the slope of the curve. In (a) the slope is the same throughout, so A is constant and (assuming, as we usually can, that B is likewise) there need be no question as to exactly what $1 - AB$ means. In (b) and (c), A is varying all the time, so one doesn't know what figure to insert for it when using the formulae. We can say that Fig. 4(b)

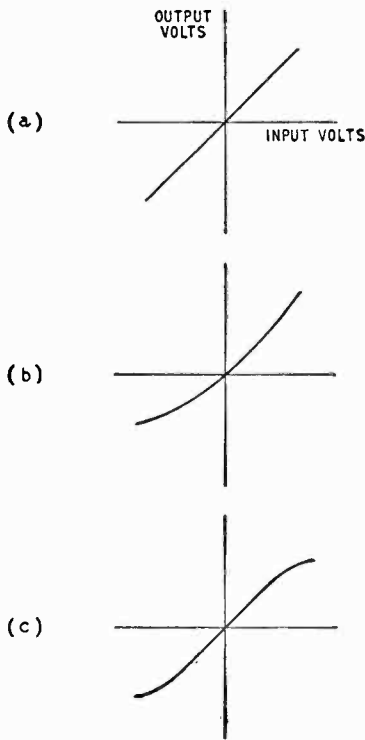

Fig. 4. In this kind of output/input graph, instantaneous voltages are plotted. (a) is a linear (distortionless) characteristic: (b) and (c) are non-linear curves, representing second and third order distortion respectively.

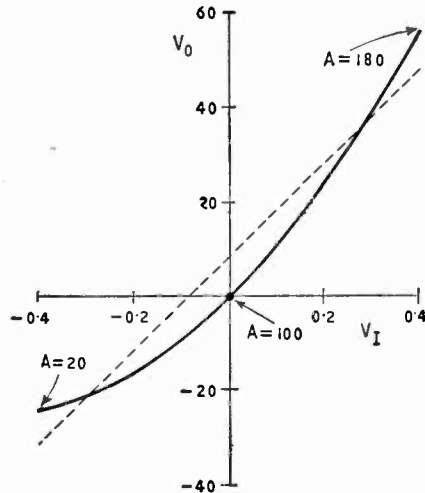

Fig. 5. The full line is a graph of the Fig. 4(b) type. The dotted line shows its fundamental part: the full-line variations from this cause second-harmonic distortion, as shown in Fig. 6.

indicates a smaller A at the negative peaks than at the positive, so presumably the negative part of the curve is straightened out less by negative feedback than the positive part, but the effect on the distortion is difficult to assess without a large-scale mathematical operation. Let us see what we can do without that.

Our example is an amplifier having a Fig. 4(b) type characteristic, which appears quantitatively as Fig. 5.

To make sure that the only distortion is second-harmonic, I have plotted it from the equation

$$V_o = 100V_i + 100V_i^2$$

where V_o is the instantaneous output voltage and V_i the input voltage. This gives the amplifier a gain of 100 as regards the fundamental.

A simple calculation shows that with a peak V_i of 0.4V the $100V_i^2$ term is the cause of 20% second-harmonic distortion. We can do it graphically by drawing a straight line joining the tips of the curve, noting how far up the V_o axis it comes (16 volts in this case) and lowering the line half that distance. It is then the linear characteristic responsible for the fundamental, shown as a pure sine wave in Fig. 6(a). The actual curve we have plotted is 8 volts lower at zero V_i and 8 volts higher at positive and negative peaks; these points can be transferred to Fig. 6(a), and when joined up by the full line show what comes out of the amplifier when $\pm 0.4V$ peak is put in. The difference between this and the fundamental has been plotted below, (b), and is clearly a second harmonic.

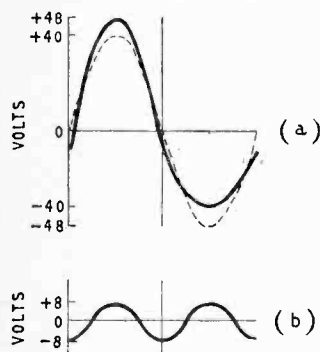

Fig. 6. (a) the full line shows the output of an amplifier with the characteristic given in Fig. 5, when the input is a pure sine-wave. The dotted line is the fundamental part, corresponding to the dotted line in Fig. 5. The difference between the two, shown by itself at (b), is a second harmonic.

Readers who hitherto may have been rather hazy about the connection between the output/input curve and the waveforms seen on a linear time base are now, I hope, feeling more confident.

Anyone with the most elementary knowledge of the differential calculus will realize that the easiest way of finding the slope (which is A) at any point on the Fig. 5 curve is to differentiate its equation, thus:

$$A = \frac{dV_o}{dV_i} = 100 + 200V_i$$

So at zero V_i it is 100, which is what one would expect, since an input confined to very small values of V_i would yield negligible distortion, and 100 is the slope of the fundamental line. At the positive peak it is $100 + 80 = 180$ and at the negative peak $100 - 80$ or only 20. So 20% distortion, which isn't so horrible as you might expect, if it is all second-harmonic, is associated with no less than a 9 to 1 variation in amplification over each cycle of signal. We can hardly be surprised, then, if we find that negative feedback doesn't work entirely according to plan.

Perhaps the best way of seeing how it does work is to plot a with-feedback curve to compare with Fig. 5, which can be done by making a table to calculate some points. Remember, the voltage fed back at any point is equal to $-BV_o$, and this added to V_i gives V'_i , the with-feedback input required.

To make it easy to compare the two curves, the V'_i scale of the new one should be the V_i scale of the

old, multiplied by as many times as V'_i must be greater than V_i to maintain the same output. A convenient figure for this, which is also typical of feedback practice, is 10. $1 - AB$ being 10, $-AB$ is 9 and $-B$ is 0.09. (This is sometimes called 9% feedback.)

(1) V_i	(2) V_o	(3) $0.09V_o$	(4) V'_i
0.1	11	0.99	1.09
0.2	24	2.16	2.36
0.3	39	3.51	3.81
0.4	56	5.04	5.44
-0.1	-9	-0.81	-0.91
-0.2	-16	-1.44	-1.64
-0.3	-210	-1.89	-2.19
-0.4	-240	-2.16	-2.56

Column (1) contains a few selected points covering the peak-to-peak swing of V_i . Column (2) contains the corresponding output voltages calculated from the equation, which were needed for plotting Fig. 5. Column (3) shows the voltage fed back, equal to $0.09V_o$. Lastly column (4), which is got by adding (3) to (1), shows the input required at V'_i to maintain the same output (2) as before.

Plotting Fig. 7 from columns (2) and (4), we are at once impressed by the success of negative feedback in straightening out the amplifier curve. It is now hardly distinguishable from a straight line, especially on the positive side.

Becoming a little more critical, we note that we need considerably more than 10 times the former positive peak input; to be exact, 13.6 times. But 10 was calculated on the basis of $A = 100$, whereas we have already noted on Fig. 5 that A varies from 100 to 180 during the positive half-cycle, and if we recalculate the average multiplier for these values of A we find it is 13.6. Rather than find fault here, we might thank feedback for raising the positive fundamental peak output from 40V with 20% distortion

(Continued on page 229)

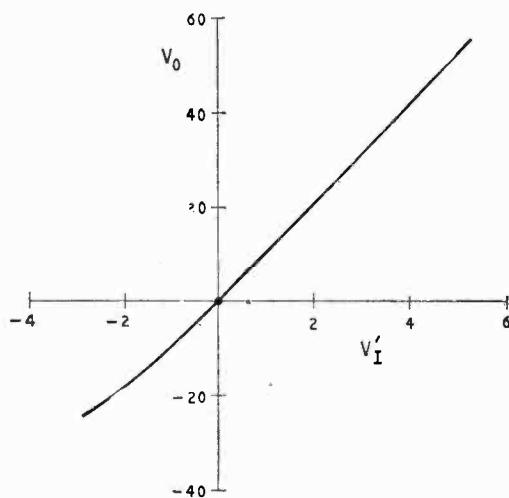

Fig. 7. This, for comparison with Fig. 5, is the result of reducing the small-signal gain 10-fold by negative feedback, and correspondingly increasing the overall input (V'_i) to yield the same net input (V_i) as before.

to 55V with about 1½% distortion, and it looks as if it could be increased indefinitely by increasing V_1 .

On the other hand, any satisfaction that might at first be derived from seeing that the input needed for the negative peak has been increased only 6.4 times is damped by the unfortunate accompanying fact that the fundamental negative peak has been reduced from 40V to about 25V. And of course a 55V positive peak is no good with a 25V negative peak—unless use of the amplifier is to be confined to rather unusual waveforms.

No; if at least our original $\pm 40V$ peak sine-wave output is to be maintained, it will clearly be necessary to bring up the negative input, as we should be able to do, seeing that we were prepared to find at least $\pm 4V$.

To see what we get we shall have to extend our plots in the negative direction. If we do, we find that beyond $V_1 = -0.5V$ a complication sets in: increasing V_1 reduces V_0 , making the curve bend up. (This could have been foreseen from the equation for A, which becomes negative directly V_1 becomes more negative than $-0.5V$). Now it is true that something like this can occur in some amplifiers, but a more likely explanation of zero A with a Fig. 4(b) type of curve is that a valve has cut off. It of course stays cut off if V_1 is made still more negative, so a more realistic procedure would be to continue the curve horizontally to the left:

V_1	V_0	$0.09V_0$	V_1
-0.5	-25	-2.25	-2.75
-0.6	-25	-2.25	-2.85
-0.7	-25	-2.25	-2.95

At this rate it is obviously going to take us a long time to reach $V_1 = -4$, but we can see which way the wind is blowing and—although such impatience is often risky with graphs—in this case we are justified in boldly writing " $V_1 = -4.00$; $V_0 = -25$."

Continuing beyond our original $\pm 4V$ (comparable with the $\pm 0.4V$ in Fig. 5) is clearly not going to make the picture look any prettier, so in Fig. 8 I have kept within those limits. Now at least we see the truth about negative feedback, and it doesn't look so good. And if anyone is thinking I've fiddled it to look worse by arbitrarily departing from the simple quadratic equation at the negative end, I invite him to stick to the equation. The result will be far more ghastly than Fig. 8.

That is bad enough, for on analysing Fig. 8* I find that the fundamental output is only just over 30V peak, compared with 40V in Fig. 5 (a power reduction of 44%), and in exchange for our 20% second harmonic we have received the following mixed bag:

2nd harmonic:	13.2%
3rd "	7.4%
4th "	3.3%
5th "	1.24%
6th "	0.16%
7th "	0.83%

plus uncounted amounts of higher harmonics, which,

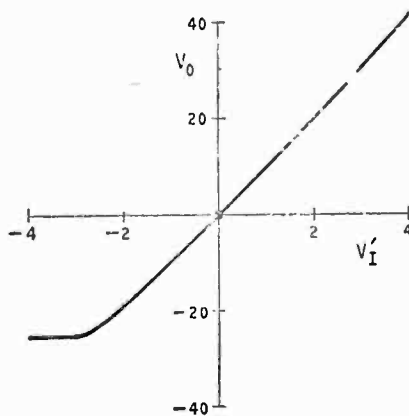

Fig. 8. The result of further adjusting the input V_1' to 10 times V_1 , positive and negative, is shown here. Audibly, the distortion would be worse than without feedback (Fig. 5).

judging from the sharpness of the bend in Fig. 8, and the magnitude of the 7th harmonic, are likely to be very significant, aurally if not numerically. It is true that the total harmonic distortion, found by taking the square root of the sum of the squares of the above lot, is 15.6%, which compares favourably with the 20% total harmonic distortion without feedback. But if anyone thinks he is thereby getting a bargain, he oughtn't to be allowed out alone in the hi-fi market. He will be an easy prey to the merchants, whose motive in quoting total distortion figures is only too clear to those who have compared actual sound reproduction with the harmonics present. Though such authorities differ as to the precise factors by which percentages of harmonics higher than the second should be multiplied to give some idea of their relative unpleasantness, the most conservative of them advocate (without necessarily admitting that it is adequate) a weighting factor equal to half the harmonic order; and D.E.L. Shorter of the B.B.C. considers the square of this factor is not excessive*. For instance, the 7th harmonic would have a weighting factor of $(7/2)^2 = 12.2$, raising the above 0.83% to over 10%.

At this point a red herring labelled "Intermodulation" is almost certain to be seen trailing across our path. But I advise that if any benefit is to be derived from the time so self-sacrificingly spent in following me thus far, we must firmly ignore it. No doubt we know that the products of intermodulation, being in general not harmonically related to the tones present in the original sounds, are more conspicuously unpleasant than at least the lower harmonics, which are; but it does not follow that one must insist on intermodulation data and refuse harmonics as worthless substitutes. For, when measured under comparable conditions, harmonic percentages are more or less proportional to intermodulation percentages. And anyway, in this case we are getting the higher harmonics, which are discordant in their own right.

Continuing our uneasy contemplation of Fig. 8, we see that there is nothing for it, if we have regard for the feelings of listeners, but to reduce our input signal until the sharp bend is cleared; say 2.5V peak.

*By the method described in M. G. Scroggie's "Radio Laboratory Handbook" (now temporarily out of print), 6th edition, Sec. 11.14.

**The Influence of high-order products in non-linear distortion," *Electronic Engineering*, April 1950, p.152.

The output, which by then is nearly all pure fundamental, is barely 25V, or less than $\frac{2}{3}$ of the power we got in Fig. 5, admittedly with lots of second harmonic too. But if we reduce the fundamental output without feedback to the same level, the second harmonic comes down to 12½%, which on paper is certainly not hi-fi, but wouldn't offend as many listeners as you might think.

It is now about time to sum up with a few conclusions:

(1) The "common belief" (that negative feedback reduces non-linearity distortion in the same ratio as it reduces amplification) is true in the simple sense only if there is no non-linearity to reduce.

(2) However, provided that the original non-linearity is not so bad that the slope of the output/input curve (which is the amplification) falls seriously below the nominal value at any point within the maximum signal amplitude, the common belief is fair enough.

(3) It follows from (1) and (2) that any idea that one can sling an amplifier together any old how and pull it straight with liberal supplies of negative feedback is unsound—even apart from the practical difficulties of this treatment.

(4) While negative feedback works like a charm on amplifiers with moderate non-linearity, run well within their powers, it doesn't necessarily increase

the amount of power that can be drawn; on the contrary, it may well reduce it.

(5) In any case, once the signal amplitude runs past the nearly-undistorted limits, it abruptly becomes very distorted, not only as regards quantity but even more as regards quality. In other words, even a moderately overloaded set sounds a lot worse with feedback than without.

(6) The fact that hi-fi fans, to whom negative feedback is a *sine qua non*, also insist (especially in America) on vast numbers of output watts being available, in spite of the surprisingly small average power required even for quite loud reproduction, is thus explained.

(7) The fact that demonstrations of "hi-fi", unless conducted by masters of the art such as Gilbert Briggs, are usually such painful experiences, is also explained. The demonstrator of an X-watt amplifier so often doesn't reckon he is doing his job if the output falls below the maximum rating.

During the whole of this investigation we have assumed that the feedback is precisely negative. That is never true at relatively high frequencies, even with the simple cathode follower, and the picture is then far worse than I have drawn. This is why sharp-cornered waveforms, which contain high-frequency components, may become horribly distorted. Perhaps it will be worth enlarging on the matter next time.

BOOKS RECEIVED

Radio, Television, Industrial Tube, Diode and Transistor Equivalents Manual, by B. B. Babani. A comprehensive equivalents list of over 20,000 devices, giving commercial equivalents, C.V. types, Service-to-civilian equivalents, and U.S.A.-to-British commercial equivalents. A replacements list is given for television picture tubes. Pp. 208. Bernard's (Publishers) Ltd., The Grampians, Western Gate, London, W.6. Price 9s 6d.

Reception of Sound and Television Broadcasting, British Standard Code of Practice CP327.201 (1960). Recommendations for good practice in installation of broadcast receiving apparatus. Reference is made to relay services, individual-set installations, communal-aerial systems, provisions for maintenance and training of maintenance personnel. Pp. 52; Figs. 8. Price 12s 6d. The Council for Codes of Practice, British Standards Institution, British Standards House, 2, Park Street, London, W.1.

Radio Stations—Installation, Design and Practice, by G. A. Chappel. Deals fully with all the aspects of high- and low-power radio transmitting-station design, installation and servicing. Includes chapters on the electrical and mechanical design of transmission lines and aerial systems. Pp. 248; Figs. 148; plates 31. Pergamon Press, Headington Hill Hall, Oxford. Price 50s.

Electrical Noise: Fundamentals and Physical Mechanism, by D. A. Bell. A complete reference and text-book on the subject of noise in electronic and physical devices. The author approaches present-day knowledge in the light of historical theories and controversies. The Nyquist theory of voltage fluctuations across resistors is dealt with exhaustively, and there is a chapter on v.h.f. valves, travelling-wave tubes, parametric amplifiers and masers; noise in metal films is also discussed. Information on measurements is included, and each chapter is followed by an extensive list

of references. Pp. 342; Figs. 98. D. Van Nostrand Company, Ltd., 358, Kensington High Street, London, W.14. Price 50s.

Beam and Wave Electronics in Microwave Tubes, by R. G. E. Hutter. A mathematical treatise on the basic principles of the family of microwave tubes. Small-signal effects only are considered, and as this is a discussion of principles, no design information is given. The author does not attempt a physical description, but confines himself to the mathematics of operation. Such microwave circuitry as is closely associated with the tubes under discussion is described, and the concept of d.c.-to-a.c. energy conversion is discussed. A chapter is devoted to noise phenomena. Pp. 378; Figs. 158. D. Van Nostrand Company, Ltd., 358 Kensington High Street, London, W.14. Price 73s 6d.

Hochfrequenz-Messtechnik, by O. Zinke and H. Brunswig. This third revised and enlarged edition is a reference book of measurements at high frequencies. The range of frequency covered is from just above the audio band to the microwave region. Instruments and their operation are described, together with methods of determining many parameters such as frequency, phase, power and impedance. Throughout, reference is made to commercial instruments relevant to the measurement under discussion, and also to the equipment specifications in the companion book, *Hochfrequenz-Messgeräte*. Pp. 234, Figs. 258. S. Hirzel Verlag, Stuttgart N., Birkenwaldstrasse 185. Price DM 24,80.

Hochfrequenz-Messgeräte, by O. Zinke and H. Brunswig. Abbreviated specifications of commercial instruments and devices for the measurement and generation of high-frequencies. Complementary to the companion work, *Hochfrequenz-Messtechnik*. Pp. 60. S. Hirzel Verlag, Stuttgart N., Birkenwaldstrasse 185. Price DM 9,60.

AMATEUR TELEPRINTING

GROWING INTEREST IN EUROPE

By ARTHUR C. GEE* (G2UK)



The author's station at Lowestoft, Suffolk, showing his Creed teleprinter.

ON the Saturday evening of the week in which the recent Radio Hobbies Exhibition was held, the British Amateur Radio Teleprinter Group held its first dinner, celebrating in doing so its first year of activity.

Amateur radio teleprinting is a very new mode of communication for the British radio amateur, for whilst this mode has been followed in the U.S.A. and Canada for a number of years, its exploitation by radio amateurs in Europe was held up by a number of difficulties. These difficulties included a certain prejudice amongst some amateurs to this method of communication, lack of information on sources of suitable equipment and uncertainty as to the licence conditions regulating this aspect of amateur radio transmission.

The group was formed in the middle of 1959 to investigate these problems and endeavour to get "RTTY," as it is designated in radio circles, introduced into the field of amateur radio activity in this country. Enquiry from the G.P.O. revealed that teleprinting by means of frequency shift keying was, in fact, permitted by the terms of the licence controlling amateur radio transmitting activities in this country. A source of suitable teleprinters was found at a price the amateur enthusiast could afford, *viz.*, around £3 to £4! Admittedly these were pretty obsolete by modern commercial standards, but they proved eminently satisfactory for the particular characteristics of amateur radio communication. The group produced and distributed news sheets, information leaflets and data so that almost imperceptibly old prejudices were broken down and knowledge of the system was disseminated throughout the amateur fraternity.

The first amateur radio teleprinting in this country took place towards the end of 1959 between Peter Carnochan's station (G3IAO) in Lowestoft, that of the author, also in Lowestoft, and that of W.M. Brennan (G3CQE) in Norwich. Transmissions were in the 80-metre band (850c/s) using f.s.k. At the 1959 Radio Hobbies Exhibition, a demonstration of amateur radio teleprinting was put on and the



Jan Adama (PAØFB) of The Hague, operating his Siemens teleprinter with autohead reperforator.

f.s.k. convertor unit used by the author for these first tests was shown working and it was briefly described and illustrated in a subsequent issue of *Wireless World*.

This demonstration was seen by Jan Adama, a prominent Dutch amateur (PAØFB), who wrote to the author early in 1960 saying he had assembled radio teleprinting gear and was ready for tests. These were soon successfully carried out with the author's station. In the meantime Mr. Brennan had been making successful contacts with RTTY stations in the U.S.A., Canada, Australia and other distant countries, and we soon learnt that Hans H. Horn, of Flensburg, W. Germany, was equipped for RTTY operation from his station DL1GP.

During 1960 there was a rapid growth of both membership of the Group and activity on the air and at the end of the year about twenty radio amateurs in this country, Holland and Germany were regularly using this mode of transmission. There is much yet to be done in popularizing RTTY amongst the European amateur radio fraternity; in extending its use to other countries; in developing equipment more suited to amateur requirements than the surplus commercial material which is at the moment widely used; and by disseminating technical information to those wishing to use this type of communication. RTTY has, without doubt, come to stay and is for the c.w. man what s.s.b. has become for the 'phone enthusiast.

*Hon. Sec. British Amateur Radio Teleprinter Group

UNBIASED

By "FREE GRID"

WIRELESS WORLD has always been noted for its meticulous accuracy, and I recollect being very greatly impressed in 1936, when the 25th birthday number was published, by the fact that the word jubilee was strictly avoided, the obvious ground for such avoidance being that the word can only properly be applied to a fiftieth anniversary, it being ultimately derived, of course, from the Hebrew festival of emancipation held every 50th year, as is described in such detail in the 25th chapter of Leviticus. This festival was always initiated by a blast from a trumpet made out of a ram's horn (Heb. Yobel).

Incidentally, the correct spelling of the word is "jubile," as the A.V. translations of Leviticus make abundantly clear (Lev. XXV, 9, *et seq*) and I have often wondered how the extra "e" got stuck on to it. I suppose it is all part of the centuries-old craze for using French feminine past participles, such as "employee," which finally gave us the offensive word "evacuee," which can only be correctly used to describe a child who has received the attentions of a nurse armed with Mr. Higginson's remarkably effective invention.

Coherer to Crystal

However, to get back to our own jubilee, *Wireless World* was undoubtedly the first journal catering solely for radio interests, but it was by no means the first to publish details of how to rig up a wireless

receiver at home. That honour belongs, I believe, to *The Model Engineer*, which gave such information over 63 years ago, in January, 1898, as I pointed out in the May, 1951, issue of *Wireless World* when I also reproduced the circuit diagram.

I certainly cannot claim to have been reading *The Model Engineer* in 1898 but, curiously enough, I did write my first technical article in one of its sister journals in the early days of the First World War. But I don't think what I wrote—nor yet the 5s I received for the article—had anything to do with the journal's subsequent decease.

It is a strange coincidence, but in 1911, when *Wireless World* was born, I built my first wireless set from a design in *The Boys Own Paper*, the idea being to receive the time signals from the Eiffel Tower. On the outbreak of war I had to surrender the set to the police, but I never reclaimed it afterwards. Judging by the primitive apparatus used at Scotland Yard in the early post-war years, as shown in the photograph on this page, I think I can see what the police did with some, at any rate, of my components.

Operation Helen

My other photograph, an instructional class of girl morse learners, was taken in the early part of the First World War when there was such a desperate shortage of manpower at sea that it was decided to put female auxiliaries aboard ship, a start being made in the wireless

room. This enterprise was appropriately enough named "Operation Helen," as it was hoped that the prospect of having beautiful girls in the ship's company would do far more than "launch a thousand ships"; it was hoped that it would also attract men eager to serve in their crews. Had I not been serving in Kitchener's army I should certainly have been an eager recruit.

In the First World War, of course, there was no direction of labour and, indeed, no conscription for the fighting forces until March 2nd, 1916. Many of my older readers in the U.K. will recall the caption of the final pre-conscription recruiting poster, "Will you march too, or wait till March Two."

Do you notice how astonishingly reminiscent of my own features are those of the portly instructress standing on the starboard side of the class. She is, at least, becomingly dressed, which is more than can be said for the girls in her charge, whose dress was considered rather daring in those days, as their ankles were visible, and in the case of one girl, several inches of leg above them. As the old music-hall song of the times said, "Who cares a damn, for Mary's little lamb, now you can see her calves?"

However, with the coming of conscription, "Operation Helen" was abandoned, with the result that sailors were deprived of many home comforts with which the girls might have eased their hard lot in their watch below.

A.D. 1971, 1986, 2011

Another 50 years will have to pass before *Wireless World* can publish another jubilee number, and that will be the centenary number of April, A.D. 2011. However, it is customary to celebrate 60th and 75th anniversaries of things. I shall be very surprised if by the 60th anniversary in 1971 we do not have coloured television and by the 75th anniversary in 1986 stereoscopic coloured TV.

By 1971 our television sets will probably have a scanning unit so that we can show our coloured slides and also our home ciné films on the c.r.t., and by 1986 our home ciné films will be returned to us from the processing station in the form of magnetic tapes holding both sound and vision recordings.

By 1986 every set will, of course, have a built-in multi-channel tape recorder for vision and sound so that while we are watching one programme we can simultaneously bottle one or more of the several alternative

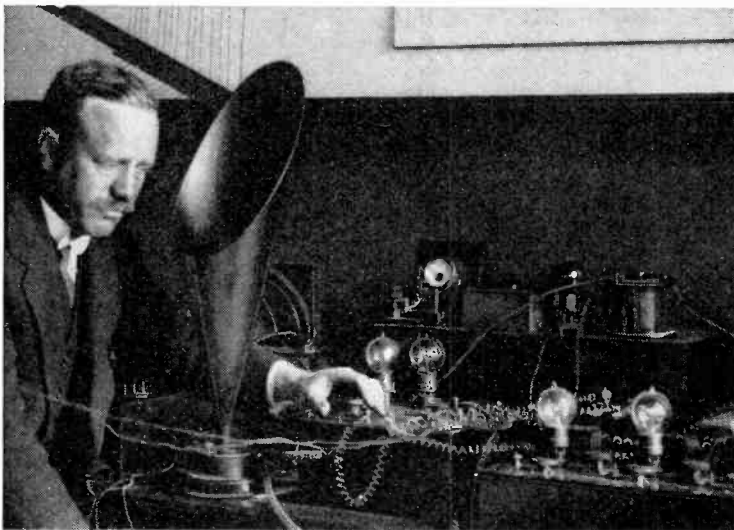

"Primitive apparatus used at Scotland Yard in the early post-war years"



"Prospect of having beautiful girls in the ship's company"

programmes which will be available. Built-in time switches will enable programmes to be bottled in our absence. There is not the slightest reason why these built-in recording facilities should not be available today in the case of our sound receivers.

Gynarchy

Long before our centenary year, the growing menace of gynarchy will have reached its logical conclusion, and all positions now sacred to the male will have been taken over by women. I have tried to imagine what the *Wireless World* editress of 2011 will probably be like. I think she will be a ravishingly beautiful blonde, but rather brainless, as is only natural since the *Wireless World* office will be fully "automatized" ("What a word!" as A.P.H. would say) and all articles will be written and sub-edited by electronic devices.

Some of you who are a bit lacking in imagination may wonder what need there will be of an editress, brainless or otherwise, in the days of full automation. Her function will, of course, be the purely psychological one of imbuing the male machine minders with a false sense of euphoria so that they give of their best; even today, some men work themselves to death just to provide dumb blondes with mink coats and Cadillacs, their sole reward being to win their soulless toothpaste smiles of approval. The blondes are not so dumb as some people think.

In the case of *Wireless World* readers of 2011, the psychological effect of the face of the glamorous editress on the cover, "in glorious Technicolor," will be to get them to accept, without complaint, articles which would otherwise cause them to

send letters of carping criticism to the editorial boudoir. Even hard-faced business-men like advertisers will be induced to buy more space than they intended.

Fettered by Physics

I will now leave the domestic scene of *Wireless World's* office and venture to glance into the future of the world of electronics, but I am definitely not going to inflict on you any of the unimaginative and rather obvious ideas which most science-fiction writers present to their readers; I except Poe, Conan Doyle and H. G. Wells. Who can doubt that the interplanetary flights of which they wrote will one day take place? Mr. Kruschev may well be on his way to Mars as you read these words. It is equally obvious that interstellar and even intergalactic flights will eventually take place; not I think by the year 2011 nor even by the year 2011² but quite probably by the year 2011²⁰¹¹.

The reason for their unimaginative stories is that writers of science-fiction allow their minds to be fettered by physics, or, more accurately, by our contemporary knowledge of physics. The sciction scribes, as I call them, write fantastic stories—doubtless accurate by contemporary scientific knowledge—about travel to distant worlds while overlooking the possibility of travel to another kind of world which is right under their noses. The world to which I refer is the extra-spatial and extra-temporal one which I discussed fully in the March, 1959, issue of this journal. I am greatly indebted to "Cathode Ray" for my ideas and gladly acknowledge it. As I explained in my original thesis on the subject, it was he who set me think-

ing by his article in the November, 1958, issue. In that article he gave us a very vivid picture of electrons as being "waves of which nobody knows" which it is usual to call ψ waves. As a result of reading this I expressed the view that if we could manage to alter one of the properties of the ψ waves such, for instance, as their λ , we should probably find that these metamorphosed electrons vanished, like H. G. Wells's Time Machine, out of our world of time and space into that extra-spatial and extra-temporal "world" inhabited by ghosts, fairies, poltergeists, and other seemingly shadowy and clammy entities who seem to pass through brick walls, to be able to be in two places simultaneously and, in general, to ignore many if not all the laws of physics.

In actual fact I don't believe they do ignore them; they merely seem to ignore physical laws because our knowledge of physics today is very limited in comparison with what it will be in the year 2011. After all, our present-day achievements in radio communications would have seemed incredible to the physicists of a century ago.

I am reluctant to call this spaceless and timeless place the meta-physical world because I don't think it is "beyond physics" as the name would imply. I will, therefore, call it the psychotronic world which simply means that it is built of metamorphosed electrons or, in other words, psychotrons, a word which I coined in the May, 1960, issue to describe these extra-spatial and extra-temporal electrons or ψ waves which had had their wavelength or other property changed or metamorphosed, and had, therefore, become $\mu\psi$ waves.

Electrovision

I will venture only one prophecy on more ordinary lines. Over a quarter of a century ago in the issue of July 20th, 1934, I described in these columns the automatic camera with self-adjusting stops and shutter speeds as I reminded you last October. This type of camera has become all the rage since last year. I wonder if I can repeat my success of 1934 by suggesting that before 2011, our electronic experts and ophthalmic surgeons will have got together to do something very drastic for people like myself suffering from failing sight.

I have in mind the development of something like the special kind of cathode-ray tube used for transmission but in very miniature form so that it would actually take the place of an eye and convert vision into pulses along the optic nerve, as the natural eye does now. It sounds nonsense. But so would a simple bread-and-butter job like an appendectomy have sounded if it had been suggested in the days of the Crimean War, or even very much later.

reflections RANDOM RADIATIONS

By "DIALLIST"

A Wonderful Occasion

AND so *Wireless World* reaches its jubilee after a wonderful record. I'm sure that congratulations and birthday "many happies" will pour in from all parts of the world and I'm glad to make my own small contribution. May it go on from strength to strength. Myself, I've been one of its readers for over forty years and have been a regular contributor for over 26 years, radiating at random in every issue since that of January 18th, 1935. Before me is a letter from H. S. Pocock dated December 28th, 1934. In it he agrees to give the feature a twelve months' trial, agrees, too, to adopt my suggestion that the title should be "Random Radiations" and that my pen-name should be "Diallist." It's my proud boast that I've never missed an issue, though some of the copy was written in pretty difficult conditions—during the war, for instance, and in the course of two or three spells in hospital. Writing "Random Radiations" has been sheer pleasure, for it has brought me innumerable letters from all parts of the world.

Looking Back

WHAT amazing changes and developments there have been since *Wireless World* was ushered into the world. Old hands will remember, as I do, fiddling with crystal and cats whisker to find the most sensitive spot. The triode valve didn't become available to amateurs until after World War I. The early ones were all hand made and for that reason they were expensive. If I remember aright the price of the "R" valve, the only one on the market after the First War, was 27s 6d, though this came down a bit as the demand grew. Then the whole position was altered by the appearance of the Mullard "Ora" valve (Oscillator, Rectifier, Amplifier), which was priced at 15s, and a little later by the coming of the Cossor "tin hat" valve, which got its name from the shape of its anode, and sold at the same price. There were few power valves in

those early days and I remember that my first 4-valve set (home made, of course) consisted of four "R" type triodes, the output going to a loud-speaker consisting of a telephone receiver and a horn. What it must have sounded like I can't think, but people were enthusiastic about the quality of its reproduction!

Before the B.B.C.

UNTIL the British Broadcasting Company, afterwards to become the British Broadcasting Corporation, started transmitting there were only two sound broadcasting stations we could listen to in this country. One was The Hague (PCGG), which transmitted for short periods three days a week; the other was the Marconi station, 2MT, at Writtle, Chelmsford, which was on the air for about half an hour on Tuesday evenings. Its presiding genius was P. P. Eckersley, who not only ran the station but also provided much of the programme himself. Then in November 1922 2LO made its welcome appearance with programmes every day.

The Set-building Boom

EVERYBODY who was, or thought he was, in the service area of 2LO, or the other B.B.C. stations as they came along in quick succession, was determined to have a wireless set. Many receivers were bought ready made but far more were probably home made. We wound our own coils, built our variable condensers (they weren't called capacitors then) and even made up our own a.f. transformers. If you're a Londoner do you remember Mrs. Raymond of Lisle Street? By that time a good few wireless weeklies of the popular kind had come into being and each of them contained every week instructions for building one or more receivers. As ready-made sets became cheaper and more plentiful the home building boom began to wane a little, though tens of thousands of receivers continued to be made by amateur enthusiasts.

Valves

THE triode with a 6-volt filament gave way to 4-volt types and later to

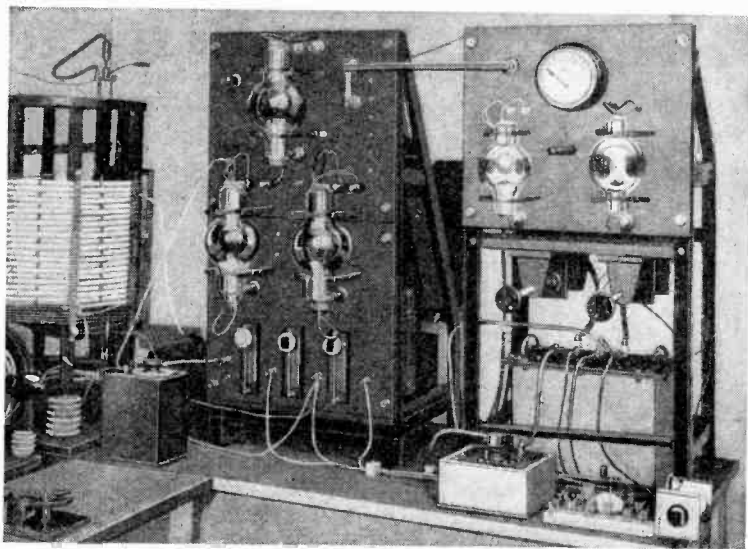

Pre-B.B.C. broadcasting station. The transmitter at 2MT, Writtle.

2-volt dull emitters. All were battery valves (you had your filament accumulator and your dry h.t.b.) for quite a time until the mains valve with its indirectly heated cathode burst on to an astonished world. All mains sets had transformers and in my humble opinion it's a thousand pities that transformerless valve chains were ever permitted. The power valve came on to the market and a sensation was caused by the appearance of the screen-grid valve and the pentode. Then all sorts of complex valves were developed—hexode, triode-hexode and a whole range, some of which are now almost forgotten.

Receiving Sets

RUMMAGING in a drawer a few days before this was written, I came across the supplement to *Wireless World* of December 9th, 1932. It's entitled "Buyers' Guide to 1933 Receivers and Radiograms" and lists the products of some eighty firms. It was a little before that that perhaps the most hideous of all receivers were made: it was usual then to mount the loudspeaker above the chassis of the set and this led to the development of cabinets with straight sides and rounded tops. They were, in fact, exactly like tombstones! The earliest sets were all single-valve or two-valve with grid-leak and condenser detectors and reaction. Reaction, misused as it so often was, could cause interference at considerable distances. A frequent item in B.B.C. news bulletins was: "Complaints of interference in the neighbourhood of X-road, Y-borough are being received. Will listeners living in that area please look to their sets."

Television

THE first television broadcasts by the B.B.C. were made on the medium waves and were received on J. L. Baird's 30-line scanning disc television. The pictures were tiny, though you viewed them through a lens, and therefore of very limited entertainment value by present-day standards. Bearing in mind the present-day craze for bigger and bigger screens it is interesting to recall that at the last pre-war radio show several manufacturers introduced sets with small tubes (some as small as 5in) in order to reduce the prices of sets. Even so there weren't a lot of television receivers in existence when World War II caused the Alexandra Palace to close down its transmissions.

CROCODILE

CLIPS

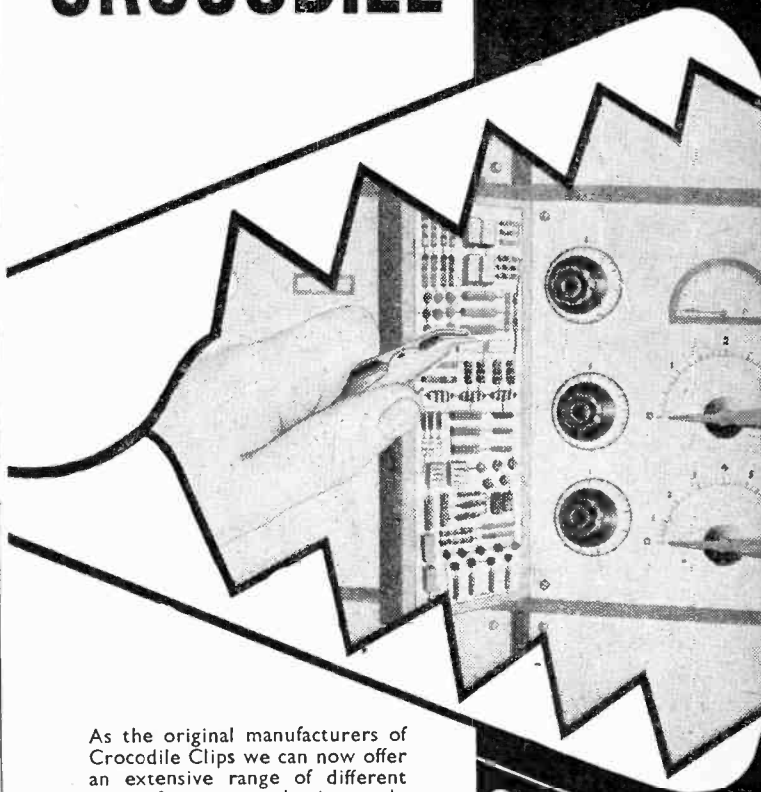

As the original manufacturers of Crocodile Clips we can now offer an extensive range of different types for your selection. In addition to the **Standard Croc Clip**, which is for general use we have types for **Tags, Fine Wire, Insulated, Terminal and Pin Grip**, and **Heavy Duty** types to carry up to 25 amps. For our standard models we also manufacture a special push fit Rubber Insulated Cover which provides absolute insulated safety.

OVER 50 UNIQUE VARIETIES AVAILABLE

Our 164 page technical catalogue published in MARCH 1960 contains illustrations, full working details and dimensions of over 10,000 ELECTRONIC COMPONENTS. Send for catalogue 201/C. Price 2/6d post free, or free to trade letterhead or order.

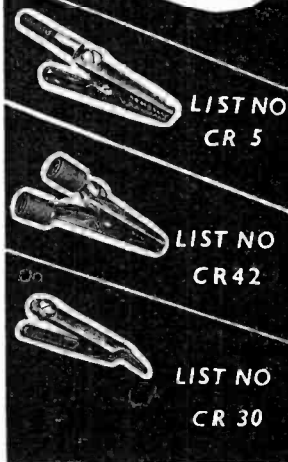

TRADE



MARK

A. F. BULGIN & CO. LTD., BYE-PASS RD., BARKING, ESSEX

Telephone: RIPpleway 5538 (12 lines)

APRIL MEETINGS

Tickets are required for some meetings; readers are advised, therefore, to communicate with the secretary of the society concerned.

LONDON

6th. Brit.I.R.E.—Discussion on "Transistorized television receivers" at 6.0 at the London School of Hygiene, Keppel Street, W.C.1.

7th. I.E.E.—Discussion on "The Conversion of biological data into electrical signals" at 6.0 at Savoy Place, W.C.2.

10th. I.E.E.—Discussion on "Applications of electrical phenomena at liquid helium temperatures" at 5.30 at Savoy Place, W.C.2.

11th. I.E.E.—"Precision instruments for coaxial line measurements up to 4Gc/s" by D. Woods at 5.30 at Savoy Place, W.C.2.

12th. Brit.I.R.E.—"Vibration analysis and testing" by D. E. Mullinger at 6.0 at the London School of Hygiene, Keppel Street, W.C.1.

12th. Society of Environmental Engineers.—"Climatic and high-vacuum environmental test chamber" by V. A. Austin at 6.0 at Imperial College.

14th. Television Society.—"Transparent phosphor screens" by Dr. D. E. N. King at 7.0 at the Cinematograph Exhibitors' Association, 164 Shaftesbury Avenue, W.C.2.

19th. Brit.I.R.E.—"Instrumentation in obstetrics" by Dr. C. N. Smyth at 6.0 at University College Medical School, University Street, W.C.1.

19th. Society of Instrument Technology.—"Electronic telephone exchanges" by T. H. Flowers at 7.0 at Mansion House, 26 Portland Place, W.1.

20th. British Computer Society.—"The recording of time series and a programme technique for handling these records on a computer" by Sir Edward Bullard at 6.15 at the Northampton College of Advanced Technology, St. John Street, E.C.1.

20th-21st. Television Society.—Convention on "Television and film techniques" at the I.E.E. Lecture Hall, Savoy Place, W.C.2.

21st. Institute of Navigation.—"Marine radar presentation" by S. R. Parsons and Capt. F. J. Wylie at 5.15 at the Royal Geographical Society, 1 Kensington Gore, S.W.7.

21st. B.S.R.A.—"Recording vision signals on tape" by Dr. P. E. Axon at 7.15 at the Royal Society of Arts, John Adam Street, W.C.2.

26th. I.E.E.—"Data transmission" by R. H. Franklin and J. Rhodes at 5.30 at Savoy Place, W.C.2.

26th. Brit.I.R.E.—Symposium on "Electronic counting techniques" at 6.0 at the London School of Hygiene, Keppel Street, London, W.C.1.

27th. I.E.E.—Kelvin lecture on "Medical electronics" by Professor R. F. Woolmer at 5.30 at Savoy Place, W.C.2.

BIRMINGHAM

12th. Television Society.—"Television in nuclear science" by Dr. P. D. Whitaker at 7.0 in the New Physics Lecture Theatre, the University.

24th. I.E.E.—Annual general meeting at 6.0 followed by "A review of progress in ultrasonic inspection techniques" by A. C. Rankin at the James Watt Institute.

BRISTOL

11th. Television Society.—"Deflection techniques for 110" picture tubes" by B. Eastwood at 7.30 in the Colston Room, Hawthorns Hotel, Woodland Road, Clifton.

19th. Brit.I.R.E.—"Colour television" by Dr. G. N. Patchett at 7.0 at the School of Management Studies, Unity Street.

CAMBRIDGE

20th. I.E.E.—"The potentialities of artificial earth satellites for radiocommunication" by W. J. Bray at 8.0 at the Cavendish Laboratory.

CHELTENHAM

21st. Brit.I.R.E.—Annual general meeting of the section followed by "The mesa transistor and its h.f. applications" by D. H. Mehrrens at 7.0 at Technical College.

EDINBURGH

18th. I.E.E.—"Radiocommunication in the power industry" by E. H. Cox and R. E. Martin at 7.0 at the Carlton Hotel.

FARNBOROUGH

18th. I.E.E.—"The future of 'electronics' and 'electronics' in aircraft and guided missiles" by Viscount Caldecote at 6.15 at the Technical College.

LEICESTER

17th. Television Society.—"A novel approach to colour television" by A. P. H. Thomson at 7.30 in Room 104, the College of Technology & Commerce, The Newarke.

LIVERPOOL

13th. Society of Instrument Technology.—"Feedback" by R. S. Medlock at 7.0 at M.A.N.W.E.B. Industrial Development Centre.

19th. Brit.I.R.E.—"The history of radio" by G. R. M. Garratt at 7.0 at the Adelphi Hotel.

MANCHESTER

6th. Brit.I.R.E.—"Plant investigation and control using digital techniques" by K. J. McCarthy at 7.0 at the Reynolds Hall, College of Technology.

10th. Society of Instrument Technology.—"Industrial application of TV" at 6.45 at the Nags Head, Jacksons Row.

26th. I.P.R.E.—"Telecommunications" by British Railways at 7.30 at the Central Hall, Oldham Street.

NEWCASTLE-UPON-TYNE

10th. I.E.E.—Annual general meeting at 6.15 followed by "Some aspects of the application of electronics to medicine" by Dr. F. T. Farmer at the Rutherford College of Technology, Northumberland Road.

12th. Brit.I.R.E.—Annual general meeting of the section followed by "Colour television" by Dr. G. N. Patchett at 7.0 at the Institute of Mining and Mechanical Engineers, Neville Hall, Westgate Road.

NOTTINGHAM

11th. I.E.E.—"The power drive and control for Jodrell Bank radio telescope" by C. N. Kington, H. A. Prime and H. T. Price at 6.30 in the Lecture Theatre, Portland Building, The University.

PORTSMOUTH

5th. I.E.E.—Annual general meeting at 6.30 followed by "The application of electronics to the electricity supply industry" by Dr. J. S. Forrest at the College of Technology.

SCUNTHORPE

19th. I.E.E.—"Silicon power rectifiers" by A. J. Blundell, A. E. Garside, R. G. Hibberd and I. Williams at 6.30 at the North Lindsey Technical College.

SOUTHAMPTON

11th. I.E.E.—"High-speed pulse techniques using transistors" by E. Wolfendale at 6.30 at the University.

19th. Brit.I.R.E.—"The development of an ammonia maser oscillator as a frequency standard" by A. Mitchell at 7.0 in the Lanchester Building, the University.

STONE

17th. I.E.E.—"The potentialities of artificial earth satellites for radiocommunication" by W. J. Bray at 7.0 at Duncan Hall.

"WIRELESS WORLD" PUBLICATIONS

	Net Price	By Post
RADIO DESIGNER'S HANDBOOK Edited by F. Langford-Smith, B.Sc., B.E., Senior Member I.R.E. (U.S.A.), A.M.I.E. (Aust.). 4th edition (revised)	55/-	57/3
PRINCIPLES OF FREQUENCY MODULATION B. S. Camies	21/-	21/10
INTRODUCTION TO LAPLACE TRANSFORMS for radio and electronic engineers. W. D. Day, Grad.I.E.E., A.M.Brit.I.R.E.	32/6	33/6
ELECTRONIC COMPUTERS: Principles and Applications T. E. Ivall. 2nd Edition	25/-	26/-
BASIC MATHEMATICS FOR RADIO AND ELECTRONICS F. M. Colebrook, B.Sc., D.I.C., A.C.G.I. Revised by J. W. Head, M.A. (Cantab.). 3rd Edition	17/6	18/6
PRINCIPLES OF TRANSISTOR CIRCUITS S. W. Amos, B.Sc.(Hons.), A.M.I.E.E. 2nd Edition	21/-	22/-
LEARNING MORSE 13th Edition H. F. Smith, former editor, "Wireless World"	1/6	1/10

A complete list of books is available on application.
Obtainable from all leading booksellers or from

LIFFE BOOKS LTD., Dorset House, Stamford Street, London, S.E.1.