

# Wireless World

August 1970 3s 6d

Television wobulator design  
Recorded colour programmes

SEP 17 1970

REFERENCE COPY

JOHN F. KENNEDY SPACE CENTER  
NASA LIBRARY

# NEW

# Tektronix 7000 Series

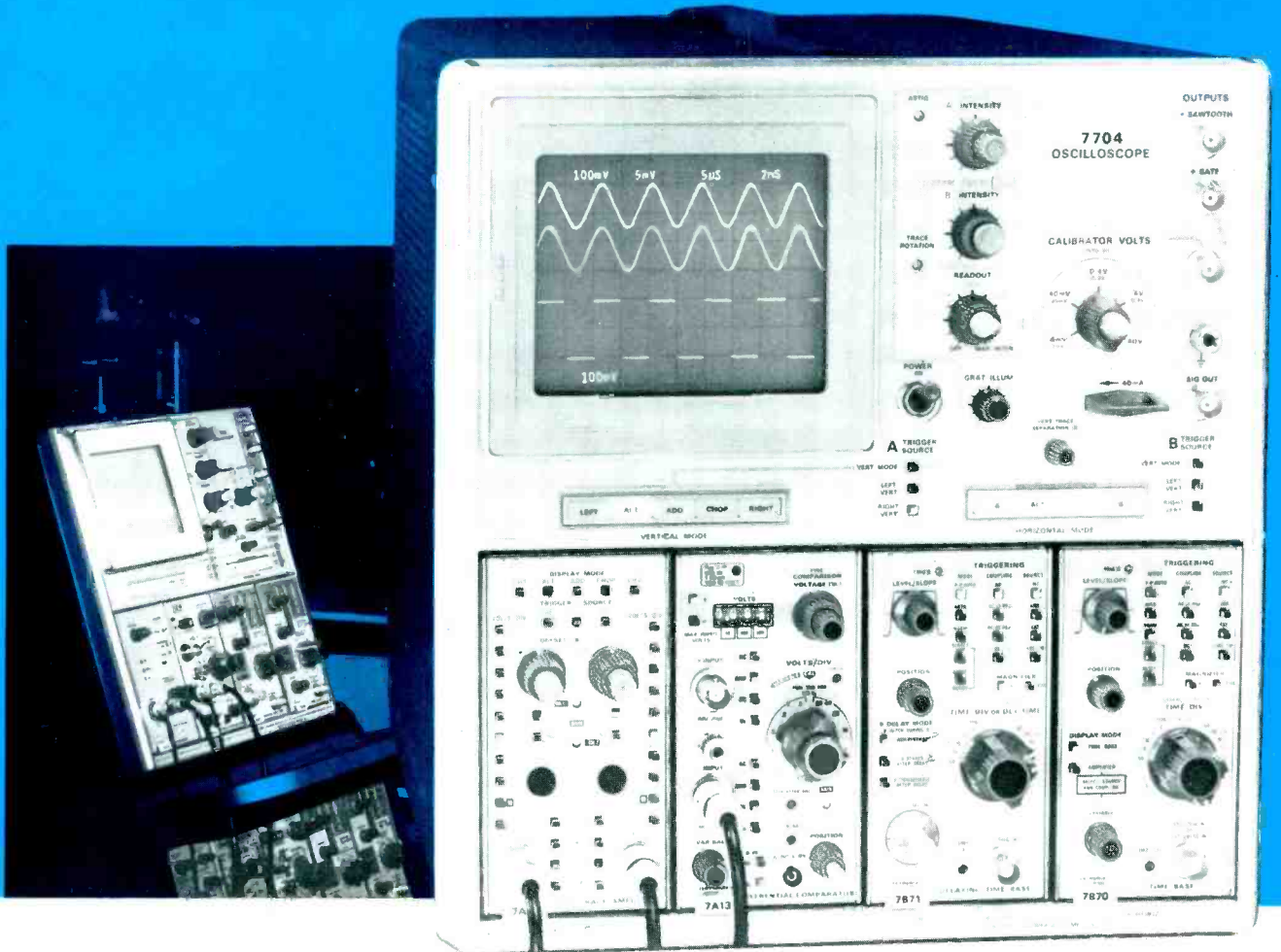

### Automatic Scale Factor Readout—

a character generator senses the position of volts/div, amps/div, time/div, polarity, and uncalibrated variable controls, then accounts for probe attenuation and displays the correct scale factors for all channels directly on the CRT. In addition to this facility, illuminated push-button switching and true automatic triggering assure faster, more accurate, less complicated measurements.

### 150 MHz Bandwidth—

using the type 7704 main-frame, 90 MHz for the type 7504.

For detailed information on any of our products, please fill in reader reply card or write, telephone or telex

### More Sensitivity—

higher sensitivities are achieved at greater bandwidths than ever before. 5 mV/div at 150 MHz, 1 mV/div at 100 MHz and 10  $\mu$ V/div at 1MHz.

### More Flexibility—

each mainframe accepts up to four plug-in units. Thirteen plug-in units are currently available to cover virtually all multi-trace, differential, sampling, and X-Y applications. Price of Mainframe (with scale factor readout) and the minimum of a single channel vertical and single time-base plug-in units:

7504 from £1,459 | delivered U.K.

7704 from £1,764 |

Manufactured in Guernsey C.I.

**Tektronix U.K. Ltd.** Beaverton House, P.O. Box 69, Harpenden, Herts.  
Telephone Harpenden 61251. Telex 25559

For overseas enquiries: **Australia:** Tektronix Australia Pty. Ltd., 80, Waterloo Rd., North Ryde, N.S.W. 2113 **Canada:** Tektronix Canada Ltd., Montreal, Toronto & Vancouver. **France:** Relations Techniques Intercontinentales, S.A. 91, Orsay, Z.I. Courtaboeuf, Route de Villejust (Boite Postale 13) **Switzerland:** Tektronix International A.G., P.O. Box 57, Zug, Switzerland. **Africa, rest of Europe, and the Middle East:** Tektronix Ltd., P.O. Box 36, St. Peter Port, Guernsey, C.I. **All other territories:** Tektronix Inc., P.O. Box 500, Beaverton, Oregon, U.S.A.



WW-001 FOR FURTHER DETAILS

# Wireless World

Electronics, Television, Radio, Audio

Sixtieth year of publication

August 1970

Volume 76 Number 1418

## Contents



Although not exclusively associated with the subject of this month's main article (colour EVR) our cover illustration typifies colour television reproduction. The photograph of a Mullard tube was taken by students at the Polytechnic School of Photography, Regent Street, London.

### IN OUR NEXT ISSUE

Inductorless stereo decoder which uses a phase-locked loop to regenerate the suppressed subcarrier.

Transistor breakdown-voltage meter providing direct reading at fixed reverse currents.

Increasing the bandwidth of the Hartley 13A double-beam oscilloscope.

ibpa

International Business  
Press Associates

I.P.C. Electrical-Electronic Press Ltd  
Managing Director: Kenneth Tett  
Editorial Director: George H. Mansell  
Advertisement Director: George Fowkes  
Dorset House, Stamford Street, London, SE1

© I.P.C. Business Press Ltd, 1970

Brief extracts or comments are allowed provided acknowledgement to the journal is given.

- 365 Editorial Comment
- 366 Colour Electronic Video Recording by Peter C. Goldmark and collaborators
- 372 Television Wobbulator—1 by W. T. Cocking
- 376 H.F. Predictions
- 377 The Video Disc by J. C. G. Gilbert
- 379 Electronic Morse Keyer by C. I. B. Trusson & M. R. Gleason
- 382 News of the Month
- 386 Letters to the Editor
- 389 100-MHz Frequency Divider by D. R. Bowman
- 394 Transient Trinity by Thomas Roddam
- 397 Announcements
- 398 Time Delays—2 by H. D. Harwood
- 401 B.B.C. Band-two Broadcasting Stations
- 402 Circuit Ideas
- 403 The Unijunction Transistor—2 by O. Greiter
- 407 Electronic Building Bricks—3 by James Franklin
- 408 Letter from America
- 409 World of Amateur Radio
- 410 Personalities
- 411 New Products
- 416 Literature Received
- A81 APPOINTMENTS VACANT
- A102 INDEX TO ADVERTISERS

We regret Pt. 13 of Active Filters has had to be held over.

PUBLISHED MONTHLY (3rd Monday of preceding month). Telephone: 01-928 3333 (70 lines). Telegrams/Telex: Wiworld Bisnespres 25137 London. Cables: "Ethaworld, London, S.E.1." Annual Subscriptions: Home; £3 0s 0d. Overseas; 1 year £3 0s 0d. (Canada and U.S.A.; \$7.50). 3 years £7 13s 0d. (Canada and U.S.A.; \$19.20). Second-Class mail privileges authorised at New York N.Y. Subscribers are requested to notify a change of address four weeks in advance and to return wrapper bearing previous address. BRANCH OFFICES: BIRMINGHAM: 202, Lynton House, Walsall Road, 22b. Telephone: 021-356 4838. BRISTOL: 11, Elmdale Road, Clifton, 8. Telephone: OBR2 21204/5. GLASGOW: 2-3 Clairmont Gardens, C.3. Telephone: 041-332 3792. MANCHESTER: Statham House, Talbot Road, Stretford, M32 0EP. Telephone: 061-872 4211. NEW YORK OFFICE U.S.A.: 205 East 42nd Street, New York 10017. Telephone: (212) 689-3250.



Chances are you'll find precisely the industrial tube you want in the BRIMAR standard range without the expense of a special.



Thorn Radio Valves and Tubes Limited 7 Soho Square, London, W1V 6DN. Telephone: 01-437 5233



WW-069 FOR FURTHER DETAILS

[www.americanradiohistory.com](http://www.americanradiohistory.com)

# Wireless World

## “Not without honour”

### Editor-in-chief:

W. T. COCKING, F.I.E.E.

### Editor:

H. W. BARNARD

### Technical Editor:

T. E. IVALL

### Assistant Editors:

B. S. CRANK

J. H. WEADEN

### Editorial Assistant:

J. GREENBANK, B.A.

### Drawing Office:

H. J. COOKE

### Production:

D. R. BRAY

### Advertisements:

G. BENTON ROWELL (*Manager*)

G. J. STICHBURY

R. PARSONS (*Classified Advertisement Manager*)

Telephone: 01-928 3333 Ext. 533 & 246.

H.R.H. the Duke of Edinburgh, speaking at the dinner of the Institution of Electronic & Radio Engineers at the Mansion House, London, in May said “The engineering professions are shirking their responsibilities if they only concern themselves with examinations and qualifications. They must take some part in the teaching process as well. Furthermore, it is quite useless merely laying down the rules for the engineering ‘generals’ and ignoring the qualifications for all the other ranks from ‘private’ upwards. The training and qualifications for each rank must be related to the requirements of the next rank up, and at each stage the vital factors of practical experience and performance in the job must be taken into account”.

Under their present charters neither the I.E.E. nor the I.E.R.E. can embrace non-chartered engineers and technicians in their membership. However, both institutions have associated technician organizations (respectively the Institution of Electrical & Electronics Technician Engineers and the Society of Electronic & Radio Technicians) which they actively support. For some considerable time there has been a movement afoot to give greater recognition to the non-chartered engineer and it was, of course, primarily for this reason that these two technician organizations in our own field were established. It will be recalled that with the setting up of the Council of Engineering Institutions the title “chartered engineer” has been granted to all members of the 14 constituent institutions in the C.E.I. The C.E.I. has been planning for some time the compilation of a register of all chartered engineers—but what of the “non-commissioned officers and other ranks”?

Nearly three years ago an *ad hoc* committee, representative of 42 different organizations with members in the technician and technician-engineer grades, was set up to establish in consultation with the C.E.I. basic qualifications for registration. This committee, the Standing Conference for National Qualification and Title (known colloquially as SQUINT) was faced with the tremendous task of finding a common denominator for technicians in as diverse trades as boilermaking and radio, building and baking, brewing and electrical installation, etc. etc. After two years of preparatory work by this *ad hoc* committee a limited liability company entitled the Standing Conference for Technician Engineers and Technicians was established to expedite the procedure necessary to give legal status to the association of professional bodies representing technicians. On July 1st an announcement was made stating that “today sees the first awards of the designation Registered Technician Engineer” under the authority of S.C.T.E.T. The designatory letters for the registered technician engineer are R.Tech.Eng. The statement goes on to say S.C.T.E.T. intends that these new registrants “shall form part of a single composite national register together with the chartered engineers and eventually with the registered technician. To this end S.C.T.E.T. is urgently pressing for constructive discussions with the Council of Engineering Institutions and other interested bodies”.

It has been known for some time that there has been discontent among certain sectors of the technician fraternity at the way the C.E.I. had been dragging its feet and the move to “go it alone” did not come as a surprise. However, six days after the S.C.T.E.T. announcement the C.E.I. issued a statement saying that it was proposing changes in its charter and by-laws to enable it “to establish and maintain a composite register for the three sections of the engineering community . . . the chartered engineer, the non-chartered engineer, and the technician”. The statement goes on to give the designatory letters “for those individuals nominated by their institutions or societies to the new sections of the C.E.I. register”. They will be CEI.T.Eng. for non-chartered engineers and Tech.CEI for technicians.

The situation, therefore, is that the “n.c.os and other ranks” of the radio and electronics fraternity, who have been in something of a “no man’s land” for far too long, now find that they are mentioned in despatches—or are they being offered terms for surrender?

# Colour Electronic Video Recording

System providing vision and sound records which can be played into the domestic television set

by Peter C. Goldmark\* and collaborators

Through a unique combination of photography, optics and electronics, Electronic Video Recording (EVR) allows recorded sound and vision programmes to be played through standard television receivers—truly a visual counterpart of the long-playing record. The nature of the recording medium lends itself to low cost, high volume production in monochrome or colour. The system, developed by CBS Laboratories, U.S.A., is compatible, in that a colour record can be reproduced on a monochrome player while a monochrome record will produce a black-and-white image on a colour receiver.

The recorded programme is contained in a cartridge, 7 inches in diameter,  $\frac{1}{4}$  inch thick, with a large centre hole resembling that in a 45 r.p.m. gramophone record (Fig. 1). This cartridge contains 30 minutes of colour vision programme (25 minutes in the U.S.A.) with two sound tracks which may be used for stereophony or for two independent sound programmes. The video information is on a special photographic base, 8.75mm wide and approximately

0.003in thick. The sound is recorded on two narrow magnetic stripes, one on each side of the photographic film.

The EVR player, which operates by flying-spot scanning, can have a number of forms. The one described here (Fig. 1) is a separate unit from which an r.f. signal carries the combined video and audio information to the aerial terminals of a colour or monochrome television receiver. For stereo sound reproduction a separate jack is available in the player. Push-buttons control the threading, stopping, fast forward, and rewinding operations of the cartridge. Methods are available to find a particular part of a programme and then stop automatically or manually to display a still picture for any length of time. Also, slow forward or reverse manual "browsing" is provided for. Since each picture is extremely small—0.130in.  $\times$  0.100in.—the record has a large storage capacity with potential as a reference library of visual information. Picture quality is equivalent to the best seen on European and U.S. television receivers.

On a suitable closed-circuit monitor, the monochrome resolution of EVR can reach 500 television lines in a horizontal direction. On a closed-circuit set-up, where full video bandwidth can be utilized, the resolution limit is set by the phosphor-dot structure of the picture tube.

The wear qualities of the cartridges are extremely good. Many hundred playings are possible without noticeable deterioration.

A major goal in the development of the system was to devise a film recording and duplication method that would permit large-quantity production of inexpensive film cartridges containing high quality programmes. After considerable study a special high resolution silver halide film was developed by Ilford Ltd. (a member of the EVR partnership in Europe). Stringent quality and size requirements resulted in the choice of direct electronography (exposing the film in a vacuum by finely focused electron beam) as the method of creating the master record. Modern films have a high capacity for information storage, and this applies particularly to those very fine grain films which are relatively insensitive to ordinary light but very responsive to the high energy present in an electron beam. The film used as the master for electron beam recording has a crystal size of less than one-tenth of a micron and the definition obtainable is of the order of 800 line pairs per millimetre. This master film too has been developed by Ilford.

With electronographic recording, modifications can be made to the original vision signal before the recording process so that the resolution and grey-scale produced on the film by the electron beam recorder are such as to give optimum overall performance. Thus, by adjusting the characteristics of the signals driving the electron beam it is possible to apply frequency pre-emphasis and to introduce grey-scale correction while restricting the density range to desired values. All these are not possible in a purely optical method of exposing the film.

The resulting picture on the film looks different from that on normal cinematography film, especially as colour pictures appear in monochrome and the colour information content is coded

\*President, CBS Laboratories, U.S.A.

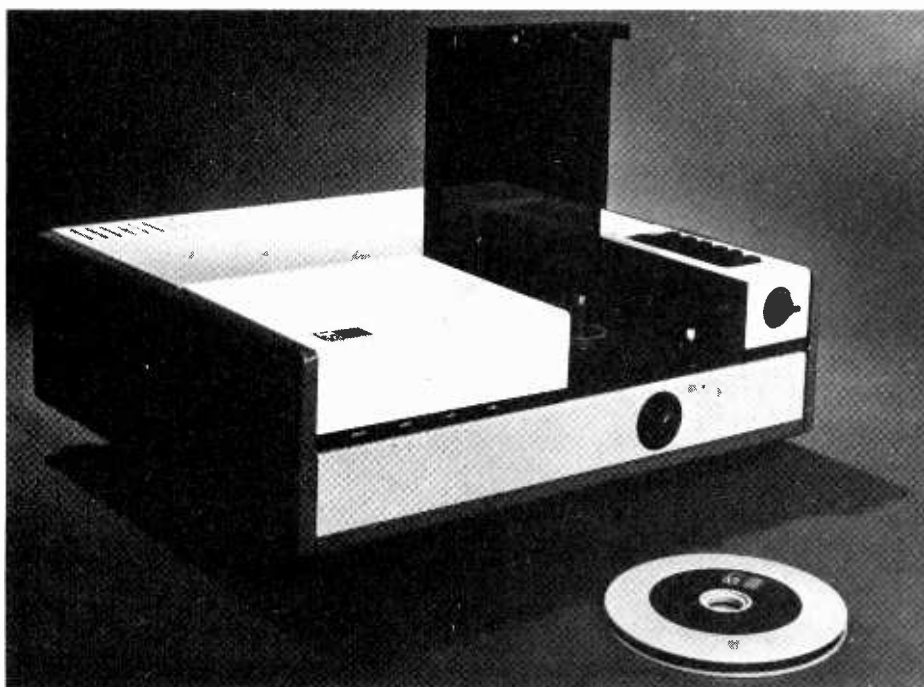

Fig. 1. Prototype EVR colour player with cartridge in front. The machine is 22in wide, 9in high and 19in deep.

(Fig. 2). An important further difference is in the number of pictures per second. In electron beam recording, and by the use of extremely fine grain print material, one is able to produce extremely small images. As a result it becomes economically possible to print 50 frames per second (60 in America). This leads to great simplification in the player machine and tends to provide a high degree of visual integration of spurious signals, such as grain or other imperfections.

The whole philosophy behind the EVR system has been to accept complexity in the recording system so as to obtain the maximum economy and simplicity in the play-back process.

### Making the cartridge

There are three principal steps in making the cartridge record: preparing the original programme; making the master negative by electron beam photography; and printing and slitting the films and loading the cartridges.

Preparing the original programme is a matter of electronically pre-correcting the video signal for any losses that will occur throughout the entire system, including the player. Thus compensation is

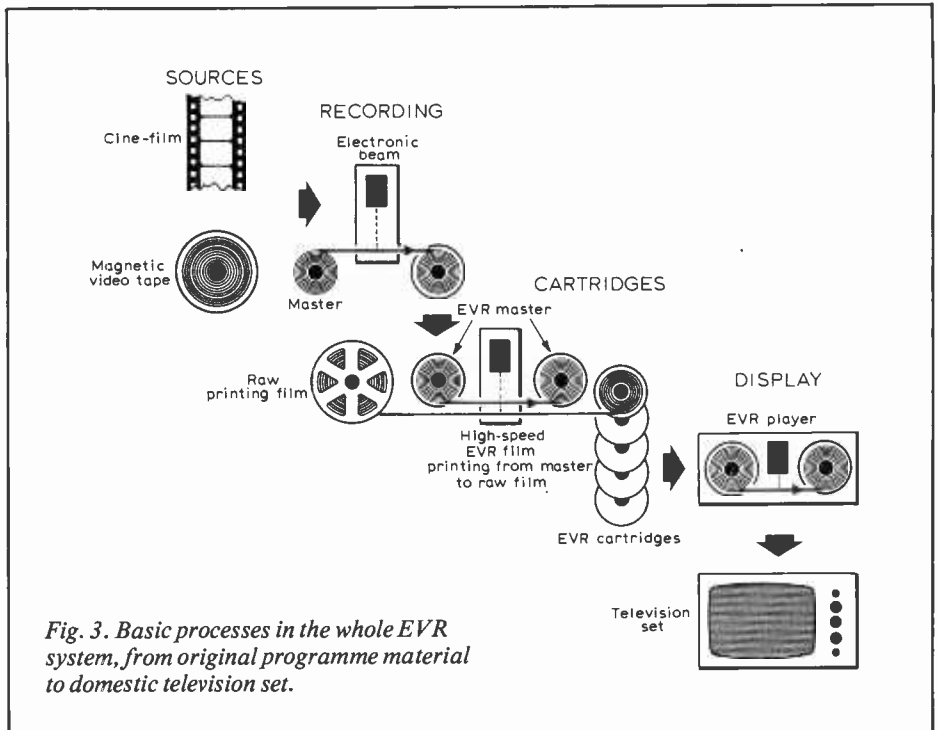

Fig. 3. Basic processes in the whole EVR system, from original programme material to domestic television set.

provided for loss of resolution and divergence from the desired scale characteristic. The original programme material is converted into a colour television signal which is separated into its luminance and chrominance components. Both signals are enhanced by vertical and horizontal aperture equalization and both are gamma corrected to ensure that the entire system approaches unity gamma.

The format of the film can be seen in Fig. 2. There is a series of frames, each having a luminance-information area seen as a picture (left-hand strip) and a chrominance-information area recorded by its side (right-hand strip). Each area is 0.123in. wide and 0.092in. high. Between the frames are small rectangular "windows" (seen as white) spaced 0.100in. apart. These are synchronizing marks indicating the start of each frame, and their purpose is to provide, in the player, a means of synchronization between the film transport and the flying-spot scanner. At the outer edges of the film are the magnetic stripes for sound.

It is essential to record the colour television signal in such a way that it can be reproduced independently of the recording and playback system's scanning linearity. In the chrominance-information areas there is recorded a colour carrier signal whose frequency is an integral multiple of the line scan frequency. In order to provide a reference carrier for the demodulation of the colour signal, an unmodulated pilot signal with a frequency exactly one half that of the colour carrier is also recorded in the chrominance-information areas of the film. Non linearity, raster size changes, film shrinkage, etc., thus will not interfere with the proper demodulation of the chrominance carrier, since the phase relationship between chrominance and pilot carriers is always maintained to the required accuracy.

The synchronizing signal generation is arranged so that the colour carrier signal is the overall system clock frequency. All synchronizing signals, as well as the pilot carrier signal, are counted down from this colour carrier signal. Because of the integral relationship between the chrominance and pilot carriers and the electron beam recorder horizontal scan frequency, the pilot and chrominance signals are recorded on the master film as a series of vertical bars.

Electron beam recorders for commercial production of master films have recently been completed for use in Europe and the U.S.A. For colour EVR the same type of machine will carry the two electron guns necessary for recording side by side the luminance and chrominance signals. A 40-mm wide film is used for the master and 35-mm film for the print. The 35-mm format accommodates four 8.75-mm cartridge films which can carry eight monochrome or four colour programmes. They are printed simultaneously and are subsequently slit. The steps in the whole process are as follows:

**Editing.** Although the recording system could operate with signals directly from television cameras, video tape or film, the advantages of editing and colour balancing can be obtained by first recording all programme material on video tape. A master tape thus produced can be easily corrected prior to transcription and the technique ensures that the signal input always meets the prescribed standards

**Video processing.** The commercial system for making a master is shown in the simplified block diagram Fig. 4. First, the video signal from a video tape recorder is separated into luminance and chrominance components. The luminance signal is fed to a video amplifier, from which one output is a direct (undelayed) signal while

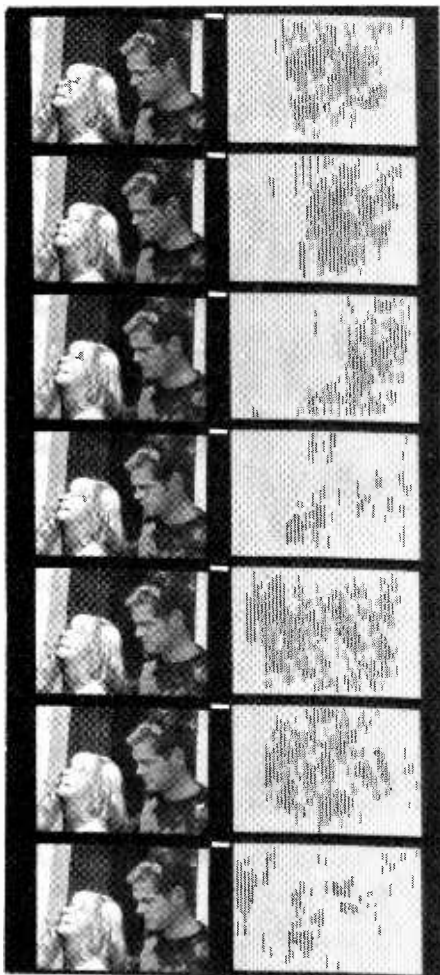

Fig. 2. Section of EVR film, showing luminance information in left-hand track, chrominance information in right-hand track, and small synchronizing windows (white rectangles) running down the middle.

the other is passed through a one-field period delay line. The purpose of this delay line is to permit video sampling at a constant rate between two successive fields. As a result, during each EVR frame, information corresponding to all 625 (or 525) lines of a television picture is recorded. The output from the delay line and the direct luminance signal are applied to independent video processing circuits. These are vertical and horizontal aperture correctors, a gamma corrector and sync "window" adder. Next, the delayed and undelayed video signals are applied to a sampling gate operating at a rate such that both fields are recombined in an EVR frame so that it contains the full 625- (or 525-) line information during a 1/50th sec. (or 1/60th sec.) television field interval. The sampled luminance signal is then applied through a video amplifier to one gun of the electron beam recorder.

The chrominance part of the v.t.r. signal, extracted from the luminance information by a filter, is translated from the television signal standard to the EVR system values. Next the chrominance signal is processed in the same manner as the luminance signal and finally is fed to the chrominance video amplifier and the second electron gun of the electron beam recorder.

The method by which an American 60 frames/sec. film is produced from a 30 pictures/sec. American television signal is shown in Fig. 5. The intercalation occurs in two steps. Using film as the programme source (though it could be video tape), the 24 frames/sec. film in the projector is changed to 30 frames/sec. as in American television and from 30 frames/sec. to a 60 frames/sec. EVR master film (the rate required for playback in the U.S.A.). The

top row shows the film frames, each frame being assigned a letter of the alphabet. Below the film frames the numbers 1, 2, 3, etc. represent successive television camera vertical scan intervals, each 1/60th second. The projector pull-down is such that alternate film frames are scanned by two and three television fields respectively.

The third row down shows the numbered fields together with the letter that represents the frame of film scanned by that numbered field. The corresponding video signal is available at the output of the "direct signal" channel in Fig. 4. The fourth row shows the field information that exists at the output of the delay line. Hence, with information from two successive fields transformed to become available simultaneously during a given 1/60th second interval, it is possible to sample synchronously the information between the successive fields at a rate well above maximum video frequency and so retain the integrity of a given television picture. The bottom row shows the sampled information that will be recorded in each frame of the EVR master.

**Electron beam recording.** Fig. 6 shows in essence how electron beam recording takes place in a vacuum chamber. As can be seen, the film is exposed by two modulated electron beams. Fig. 7 shows the vacuum chambers and film transport of the recorder. (The film magazine capacity is 1800 feet of 40mm film.) The two electrostatically focused and deflected electron guns can be seen in a gun chamber above the film transport mechanism. The gun chamber is supported on two trunnions and can be indexed to four discrete horizontal positions, thus making it possible to sequentially

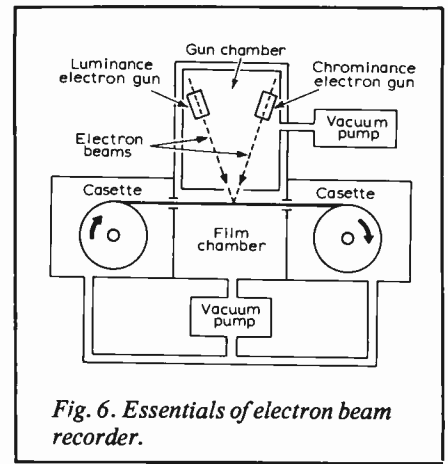

record four dual tracks across the width of the 40mm film.

Vertical deflection of the modulated electron beam follows the direction of film motion with twice the film velocity. As shown in Fig. 8, the vertical scan starts at the top (A) of the film image and after 1/50th (or 1/60th) second reaches the bottom of the frame while the film has moved from position 1 to position 2. During vertical blanking the electron beam returns to start the process over again with film frame No. 2.

During recording the beam is deflected vertically, between two adjacent lines, at a 14MHz rate. The phase of this wobble signal is adjusted so that the video information from the delayed signal is recorded along one horizontal line on the film while the video information from the direct (undelayed) signal is recorded on an adjacent line on the film. A peak white synchronizing window signal and a grey scale test signal are gated in with the video signal and are recorded at the start of each luminance field.

The film drive used in the electron beam recorder provides accurately controlled continuous motion at 5 in./sec. for Europe and 6 in./sec. for the U.S.A. An electronic servo causes the film to be driven at constant velocity while locked to the v.t.r. This servo has three closed loops. In one loop a 7kHz signal from an optical tachometer on the drive motor shaft is fed to a discriminator circuit whose output controls the motor to compensate for speed variations. The same 7kHz signal also provides one of the inputs to the second loop, in which the actual motor speed is set by comparing the tachometer output with a 7kHz reference signal from a crystal controlled oscillator. The third loop establishes the spatial position of each frame on the film with respect to an associated perforation in the film. One edge of the film is perforated along its length at 0.1-in. intervals and is transported past an optical sensor which generates a pulse for each of the perforations. In the loop the phase of the vertical drive signal and a "perforation signal" from the film are compared in order to ensure accurate phase lock between the vertical scan and a given perforation.

Interlocking the electron beam recorder film drive with the v.t.r. is accomplished by

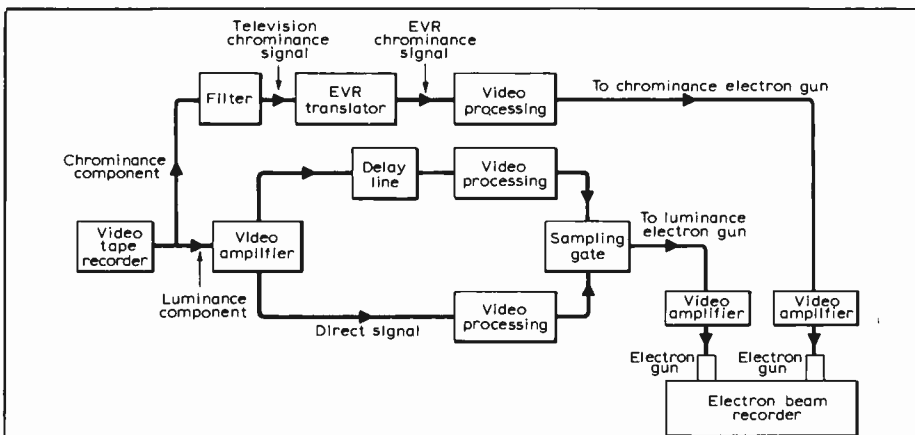

Fig. 4. Simplified block diagram of system for making master film.

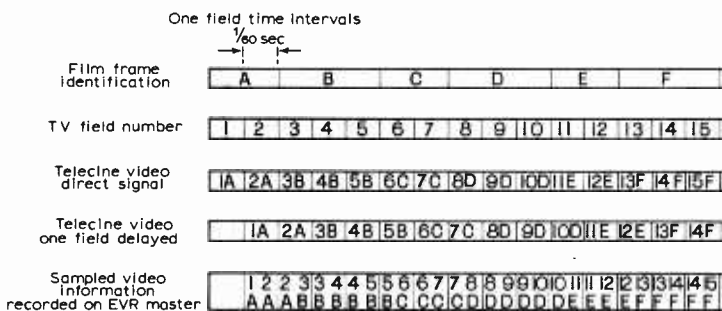

Fig. 5. Intercalation method for making an EVR film from a television (or cine film) programme source.



counting the vertical sync intervals on the magnetic tape and the perforations in the master film. The counts are compared, and the speed of the recorder drive is varied until they are equal. Interlocking between the two drives occurs within 12.5 seconds.

**High speed duplication.** For the production of EVR cartridges a special multi-head printer has been developed by Ilford Ltd. in the U.K. This equipment is capable of running at speeds of up to 200 feet per minute. The design minimizes light dispersion and protects the master film so that a large number of copies may be made.

Through the use of multiple heads, 16 colour programme reproductions, together with the sound, are obtained each time the master negative passes through the printing machine. Thus, the rate at which the printer produces EVR copies is approximately 125 times (in America 100 times) faster than the actual playing time of the original programme. If the programme is half an hour long it can be duplicated at the rate of one cartridge every 14.5 seconds.

The film is developed in black-and-white continuous film developing machines which will run at speeds of up to 200 feet per minute. The processed film then goes to a slitting machine which divides the 35mm film into four 8.75mm films. These are cleaned and wound directly on to EVR cartridges.

The sound is recorded on the two tracks during the printing process. Magnetic recording was chosen after careful consideration, the important factors being long life with high quality and low noise and the ability to change the sound track when required. The fact that magnetic reproduction in the player is less expensive than reproduction of optically recorded sound was another consideration. The sound recordings are made individually, and synchronizing marks are incorporated in the vision recording and the special sound recording so that when they are brought together in the printing machine the sound can be added in exact lip synchronism.

### The player

Fig. 9 shows a laboratory prototype player with the cover removed, exposing

the cartridge deck, c.r.t. and associated circuitry, all of which are mounted on an internal metal frame independent of the cabinet. A cartridge is played by opening the door over the well, placing a cartridge on a hub and closing the top. To the right of the well are six pushbuttons for controlling deck functions. Pressing a "play" pushbutton causes the cartridge leader to thread through the deck. After the leader is securely fastened to a take-up reel (seen behind the cartridge) the machine automatically starts to play. Other controls on the top are a track selector and mains switch. The large knob on the front is for manual searching—to move the film backwards or forwards while viewing still pictures.

The 3-in. diameter cathode-ray tube scans the film image through an optical system and the resulting modulated light is converted by photomultiplier tubes into luminance and colour signals. The c.r.t. scans each picture on the film once per television field. To accomplish this, a capstan and pressure roller pull the film past an optical gate at a constant velocity of 50 frames/sec. or 5in./sec.

Optical scanning of the luminance track of the EVR film, shown in Fig. 10, employs a forward raster scanning technique. The colour track of the film is similarly scanned through a second objective lens by the same c.r.t. raster.

At the start of the field the light beam from the c.r.t. spot scans the head of the first picture (a). As the film moves at a constant speed of 5in./sec. the beam also moves in the same direction but at twice the velocity. Thus, by the time picture 1 has moved to the position shown at (b), the light beam has completely scanned it and now rests at the foot of picture 1. At this instant, a vertical sync pulse, derived from light flashing through the clear "window" in the film (Fig. 2), initiates vertical flyback of the c.r.t. electron beam. As a result the c.r.t. spot and light beam returns and comes to rest at the top of picture 2 ready to start the next scanning period, as shown at (c).

Since the timing of the c.r.t. scanning spot is controlled by the film velocity, the film speed can vary within a limited range

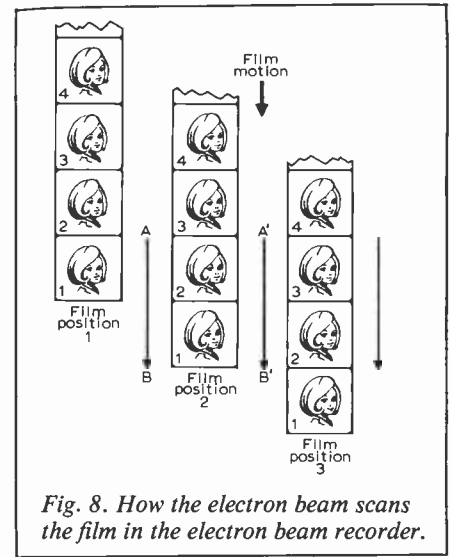

Fig. 8. How the electron beam scans the film in the electron beam recorder.

without affecting the vertical position of the reproduced television picture. Ultimately, of course, the television receiver sets the limit by losing vertical hold if the film departs too much from the nominal speed of 50 fields/sec. To prevent this from happening, the film drive is servo locked to the 50Hz mains by a circuit that compares the recorded film field pulses with the mains frequency.

The sync "windows" in the film are illuminated by a miniature incandescent lamp coupled through a plastic light pipe to the film gate. Each time a sync "window" passes the end of the light pipe, there is a flash of light through the film into a photodiode, the output of which is clipped to generate constant amplitude sync pulses.

**Optical system.** The luminance and colour tracks of the film are scanned through a dual optical system. The imaging optics (Fig. 11) comprise two lenses, two rhomboidal prisms, a lens mount which provides both focus and position adjustments for the two lenses, and a film gate which holds the film in a cylindrically curved image plane. Each lens images the 1.48in.  $\times$  2.08in. raster of the c.r.t. onto an area in the image plane 11.3 times smaller, thus forming two identical side-by-side small rasters with centres 0.141in. apart. The prisms permit separation of the two lenses and a resulting larger lens diameter sufficient to obtain an aperture of  $f/1.8$  for each lens. The collector optics are two light pipes which transmit the modulated light from the luminance and chrominance images on the film to two photomultipliers.

**Player circuit.** Anyone versed in television engineering should be at ease with an EVR player because it resembles a television receiver. Basic elements of a colour player for working into an American television set are shown in Fig. 12. These include: c.r.t. deflection and high voltage supply; transport deck and gate; dual photomultipliers and video amplifiers; chrominance translator for converting EVR signals to N.T.S.C.; pulse generation for blanking and composite sync; sound magnetic head, audio amplifier and intercarrier sound generator; r.f. link video and sound

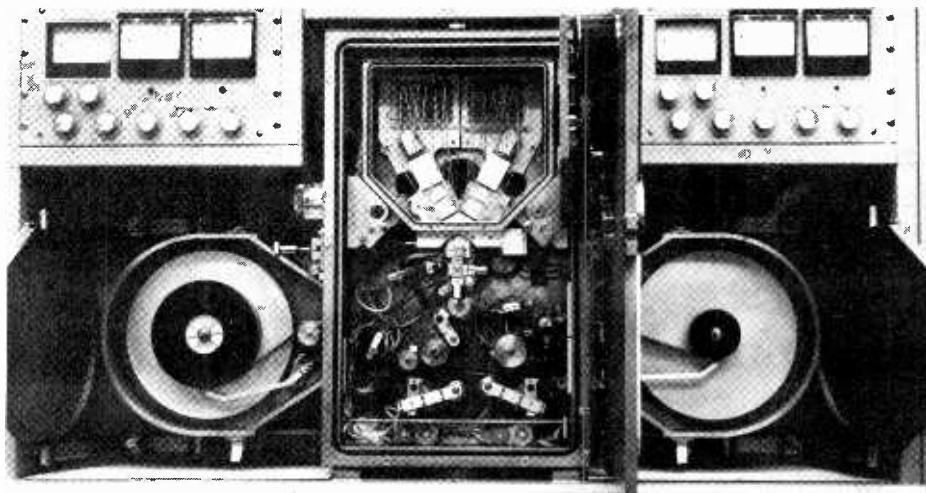

Fig. 7. Details of film transport and vacuum chambers of the electron beam recorder.

modulators and carrier generators; and the motor control circuit.

The 3-in. c.r.t., which is  $9\frac{3}{4}$  in. long, has a flat faceplate. The P-16 screen phosphor is uniformly fine grained and glows a dull blue because much of its energy is in the invisible ultraviolet region. Magnetic focusing and deflection are employed. Horizontal deflection is provided by a 15.75kHz oscillator, amplifier, and magnetic yoke. Vertical scanning is from a synchronized multivibrator and amplifier. Unregulated 20kV e.h.t. for the c.r.t. is derived by rectifying the line flyback pulse. Regulation is unnecessary because the unmodulated electron gun is a constant load drawing a maximum of  $100\mu\text{A}$ . The horizontal deflection circuit also generates  $-600\text{V}$  for the photomultipliers and  $+1\text{kV}$  for the  $g_2$  of the c.r.t. Since failure of either the horizontal or vertical deflection current might burn the phosphor screen, the circuit is protected by a scan fail device that cuts off the c.r.t. beam current before damage can occur.

The raster light output is kept constant throughout the life of the c.r.t. by an automatic brightness control. It is known that the P-16 phosphor, as it ages, has a decreasing light output, and the initial beam current of  $10\mu\text{A}$  has to be increased to about  $80\mu\text{A}$  after 1000 to 2000 hours to maintain constant brightness. The closed loop of the automatic brightness control includes a photo-resistor, positioned to view the raster, and a circuit for controlling the bias of the c.r.t.

The deck transport in the player is mechanically more complex than an ordinary tape deck because of the automatic cartridge handling functions. The film drive, applied through a smooth capstan and rubber pressure roller, is similar to that of a standard tape recorder. The film runs in a gate, curved to make the film more rigid and with lands to protect the film picture. The capstan drive motor also supplies forward torque to the take-up

reel through a friction clutch. For rewinding, the torque is transferred to the cartridge spindle.

**Video circuits.** Modulated light transmitted through each light collection pipe is converted by the corresponding photomultiplier to a video signal of about 0.1 volt. As a result the succeeding video amplifiers have little effect on the signal-to-noise ratio. Video signals are pulse clamped to remove hum components and sent through white compressors to linearize the "white-stretched" film transfer characteristic. This is also a simple and effective way to reduce the visibility of c.r.t. phosphor structure and film grain clusters in the television picture (the individual film grain is far smaller than the resolving power of the player). Phosphor grain noise is predominantly visible in the white portions of the picture since the grain modulation is proportional to light output.

A programme selector switch for the user has three positions: Colour, Track A, and Track B. For colour cartridges, the switch directs the clamped luminance video signal into the Y channel and the signal to the translator. When a monochrome cartridge is played, either Track A or Track B can be switched into the Y channel.

**Chrominance translator.** As already explained, the colour track on the film carries the chrominance information together with the pilot signal. The chrominance is composed of two colour difference signals modulating a suppressed carrier in phase quadrature. The subcarrier frequency is 1.8MHz and the bandwidth of the colour difference signal sidebands is  $\pm 0.5\text{MHz}$ .

No attempt is made to scan over the lines originally recorded on the film, and each picture is composed of 525 lines (625 in Europe). In order for the chrominance subcarrier to be a series of vertical bars

rather than interleaved dots the EVR subcarrier is made a multiple of the line scan frequency. The scanning width and linearity of the electron beam recorder, as well as of the flying spot scanner, cannot possibly be uniform enough to ensure constant frequency and phase for the chrominance subcarrier in all parts of the picture. Therefore, as already mentioned, a continuous pilot signal is added to the chrominance sidebands during recording to make the system self-correcting on playback.

The EVR chrominance colour difference signal bandwidth is the same as the  $Q$  bandwidth in the N.T.S.C. system:  $-6\text{dB}$  at 0.5MHz. In EVR, the  $I$  and  $Q$  bandwidths are made equal because nearly all colour television receivers are designed with equally narrow bandwidth colour difference demodulators.

The reproduced chrominance could be demodulated to the baseband colour difference signals and re-encoded to N.T.S.C., but it is appreciably simpler to convert EVR to N.T.S.C. directly by frequency translation. The translator section of the player can be seen in the lower middle part of Fig. 12. The combined signal from the film is first separated into chrominance and pilot signals by filters. The chrominance channel uses a 1-2.5MHz bandpass filter and the pilot channel a 1-2.5MHz band-reject filter. The 0.9MHz pilot signal is doubled to 1.8MHz and applied to mixer A together with a locally generated 3.58MHz sinusoidal oscillation. The 5.38MHz sum signal output of mixer A is selected by a bandpass filter and applied to mixer B together with the chrominance signal centred on 1.8MHz. The difference frequency of 3.58MHz from mixer B is extracted by a bandpass filter and becomes the N.T.S.C. chrominance signal.

An analysis shows that, regardless of a shift in EVR chrominance frequency, the frequency of the chrominance output of the translator will remain constant at 3.58MHz. Furthermore, if the 3.58MHz carrier is frequency interleaved by being an odd multiple of half the line scanning frequency then the resultant N.T.S.C. chrominance is equally frequency interleaved.

Care is taken to keep the phase/frequency characteristics of the chrominance and pilot channels alike to prevent hue errors with scan velocity changes. If the chrominance and the doubled pilot signals undergo equal phase shifts, the errors cancel in the translator. Delay in the pilot channel is approximately  $1.6\mu\text{s}$  greater than in the chrominance channel, making it necessary to insert a delay line in the chrominance path.

The translator has a total delay of  $2\mu\text{s}$ , thus requiring that the luminance channel be delayed an equal amount before the N.T.S.C. chrominance signal is added to the luminance signal. Following this, blanking, sync and burst signals are added to generate the composite N.T.S.C. signal. The colour burst is obtained by gating the 3.58MHz locally generated signal with a pulse. Prior to this, the 3.58MHz source

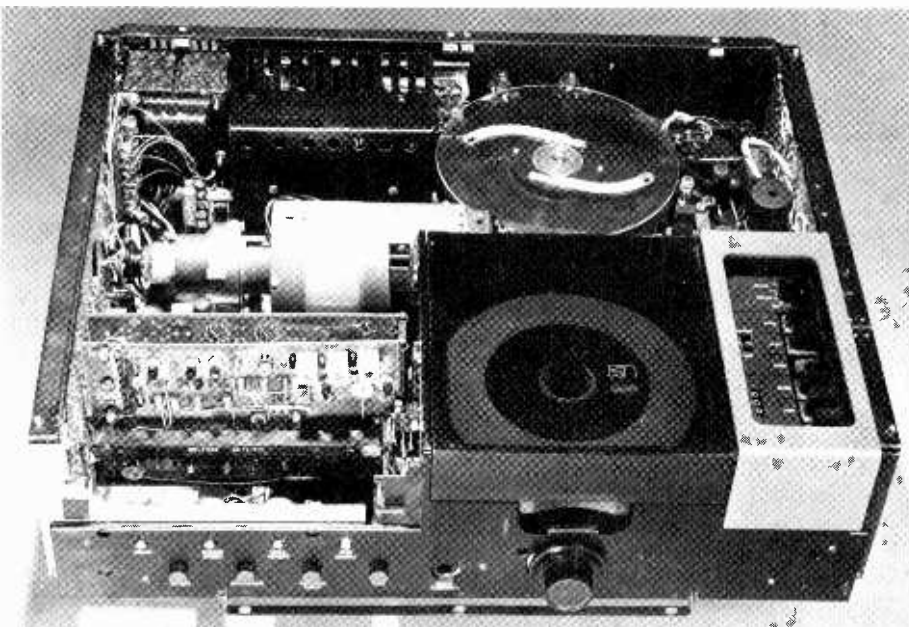

Fig. 9. The prototype player with cover removed and a cartridge inserted. The take-up reel can be seen behind the cartridge. The c.r.t. lies between them.

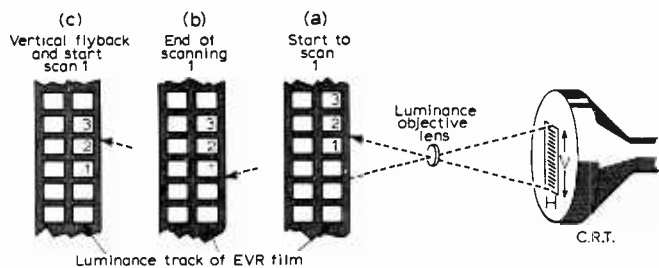

Fig. 10. Method of scanning the luminance track of the EVR film: (a), (b) and (c) are successive moments in time.

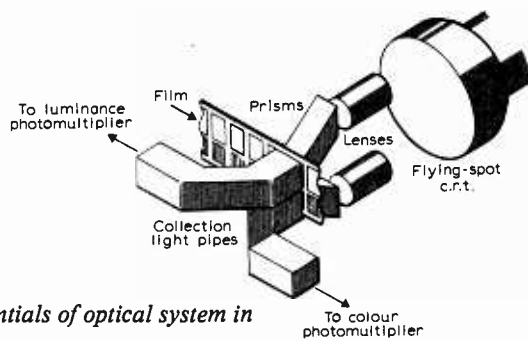

Fig. 11. Essentials of optical system in the player.

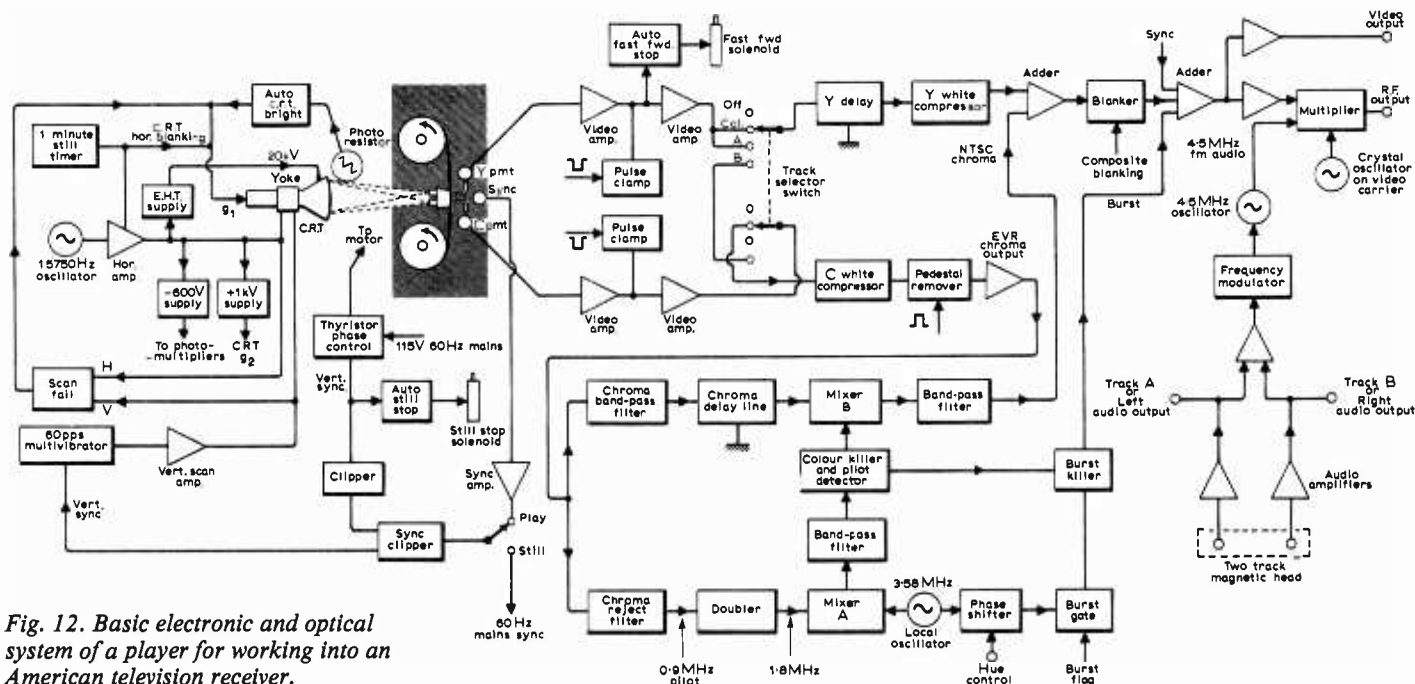

Fig. 12. Basic electronic and optical system of a player for working into an American television receiver.

is set to the correct phase by the player's hue control.

A colour killer is used to disable the colour circuit whenever a monochrome cartridge is played, otherwise spurious beats would show in the picture. With monochrome film, the absence of the pilot signal is sensed and both the chrominance and colour burst are removed from the outgoing video signal. The absence of burst actuates the colour killer in the colour television receiver, thus cleaning up the monochrome picture. This feature is especially important when colour and monochrome portions are intermixed for certain educational programmes

**Sound reproduction.** For monochrome cartridges, a track selector switch automatically selects the appropriate audio amplifier channel for that programme. A specific recording and playback equalization for 6in./sec. film speed provides a frequency response reasonably flat from 60Hz to 10kHz. Direct audio outputs at 600 ohms impedance are available at the rear of the player. Also, a single-channel audio signal is used to frequency modulate a 4.5MHz oscillator to generate the inter-carrier sound for the r.f. link.

**R.F. link.** The output of the player is fed to the television receiver through its aerial terminals by means of a miniature television transmitter operating on an unused v.h.f.

channel. Double-sideband video modulation is employed for economy, but television receivers accept the signal as if it were a vestigial sideband signal from a broadcasting station.

An improved r.f. unit is employed in the colour EVR player to satisfy requirements for low phase and intermodulation distortion. An r.f. carrier from a crystal oscillator is applied to one input of an analogue four-quadrant multiplier while the N.T.S.C. video and the 4.5MHz sound intercarrier are applied to the other input. Since the multiplier normally generates a suppressed-carrier signal, the multiplier is intentionally unbalanced to produce the desired carrier.

**Power supplies and motor control.** Regulated low voltage power supplies keep the player performance constant when the mains voltage varies over wide limits. The all-transistor circuit draws 100 watts with an additional 35 watts for the motor.

Locking the film velocity to the mains reduces the visibility of hum bars. Also, this ensures that the field scanning rate stays within the vertical hold range of the receiver. The vertical stability of the EVR picture is primarily a function of the vertical synchronizing signal derived from the film rather than being dependent on the motor lock. Therefore the motor must be frequency locked, but need not be phase locked, to the mains. During playback, the four pole, shaded-pole, induction motor is servo controlled by a thyristor.

## APPENDIX

### Characteristics of the EVR encoded colour signal

The EVR colour signal,  $E_m$ , consists of the linear sum of a pilot signal,  $E_p$ , a chrominance signal,  $E_c$ , and a colour difference video signal,  $E_v$ :

$$E_m = E_p + E_c + E_v.$$

The pilot carrier frequency,  $f_p$ , is the 56th harmonic of the line scan frequency,  $f_h$ :

$$f_p = n f_h \quad n = 56.$$

The chrominance carrier frequency,  $f_c$ , is the second harmonic of the pilot carrier frequency:

$$f_c = 2 f_p.$$

The chrominance signal consists of the sidebands of two suppressed carriers in quadrature:

$$E_c = E_Q' \sin(2\pi f_c t) - E_I' \cos(2\pi f_c t).$$

The amplitudes of the quadrature carriers are obtained by matrixing the red, green, and blue video signals:

$$E_I' = 0.60 E_R' = 0.28 E_G' - 0.32 E_B'$$

$$E_Q' = 0.21 E_R' - 0.52 E_G' + 0.31 E_B'.$$

The pilot signal is given by:

$$E_p = A_p \sin(2\pi f_p t)$$

A bandwidth limited colour difference video signal,  $E_v$ , corresponding to  $-E_I'$  of amplitude  $k$  relative to  $E_I' \max$  is added to the pilot and chrominance signals to achieve minimum peak-to-peak excursion of the composite signal envelope:

$$E_v = -k E_I'.$$

# Television Wobbulator

## 1. Principles

by W. T. Cocking\*, F.I.E.E.

Correct alignment of a wideband amplifier, such as a television i.f. amplifier, can rarely be carried out successfully merely by adjusting the various tuned circuits for maximum output at certain specified frequencies. It is usually necessary for the response curve of the amplifier to have a certain required shape, and the circuits must be adjusted to produce this shape. This means that it is necessary to measure the response curve. To do this with a signal generator and an output indicator is quite a laborious process and one which takes a considerable amount of time.

It is not unreasonable to do it once as a check that an amplifier is indeed functioning correctly. To do it frequently, while aligning the amplifier is another matter. Fortunately, it is not necessary to do so if one has the proper equipment. It is not difficult to arrange for the response curve to be displayed on the screen of a cathode-ray tube. One can then see how the shape of the curve varies with the various amplifier adjustments as they are made.

The requirement is to have an oscillator which is modulated in frequency so that its frequency sweeps repetitively over the required range. The output of the detector of the i.f. amplifier is applied after amplification, to the Y-plates of the c.r. tube, and the voltage applied to the X-plates is arranged to vary with time in the same way as the oscillator frequency varies with time. The actual law of variation with time does not matter at all as long as both obey the same law.

The curve is displayed in the usual way with frequency for the horizontal scale, but the vertical scale is normally a linear one. Most curves which are plotted as the result of point-by-point measurements are plotted with a decibel scale, which is a logarithmic scale. It is not impossible to obtain such a scale on a c.r. tube, but it is much more difficult because it requires the use of an amplifier which has an output accurately proportional to the logarithm of its input.

For 625-line television the present standard for an i.f. amplifier is to have the vision carrier at 39.5MHz with the sound carrier at 33.5MHz. The amplifier usually has trap circuits to give specially high rejection at frequencies of 31.5MHz and 41.5MHz. To give a little in hand, therefore, the

frequency sweep needed is from 30.5MHz to 42.5MHz which is a band of 12MHz centred on 36.5MHz. The total sweep is almost one-third of the mid-band frequency and is thus very considerable indeed.

A great many methods have been used in the past in wobbulators, as swept-frequency oscillators of this type are usually called. Most of them are useless for a sweep as great as one-third of the mid-band frequency, especially when that frequency is as high as 36.5MHz, and especially when transistors are used. One method which has been employed is to have the oscillator at a much higher frequency, perhaps 500-1,000MHz, so that the sweep is a much smaller fraction of the mid-band frequency. The output is then mixed with the signal from another oscillator having a frequency which differs by the required intermediate frequency, so that the frequency range is obtained as the difference frequency, just as in the ordinary superheterodyne.

This had the advantage that the output can be brought to any required frequency merely by altering the frequency of the beating oscillator. However, it is rather complicated and there is a risk of spurious responses arising from harmonics.

If it can be done at all, it is much simpler to modulate directly an oscillator operating at the required output frequency. Recently a new way of achieving such modulation has made its appearance as a result of the development of a new semiconductor device, the varactor diode. This is a diode which is specially designed to

provide a capacitance which varies with the voltage applied to it. It can be used, therefore, as a tuning capacitor, tuning being effected by varying a voltage. It is, in fact, becoming increasingly used as a tuning capacitor in domestic receivers.

When reverse-biased to be non-conductive, all semiconductor junction diodes have a capacitance which varies with the applied voltage. To put it rather crudely, a non-conductive diode has internal charges of opposite sign on the two sides of the junction, and the capacitance results from the electric field between these charges. If the reverse bias is increased, the charges are forced further apart and the capacitance decreases. It is as though a parallel-plate capacitor had the separation of its plates varied by some control voltage.

The ordinary diode exhibits the effect, but the magnitude of the capacitance is usually rather small, the range of capacitance variation is much too small, and the capacitance is accompanied by quite high losses. It is another matter with a diode specially designed for use in this way.

One example, and the one which is used in this equipment, is the Motorola 1N5145A. It is rated for a maximum reverse voltage of 60V, and a capacitance of 27pF at 4V with a normal capacitance ratio between these voltages of 3.4:1 and a minimum ratio of 3.2:1, and with a  $Q$  of not less than 200. The frequency ratio required is  $42.5/30.5 = 1.395$  and the capacitance ratio is thus 1.94, which is almost 2:1.

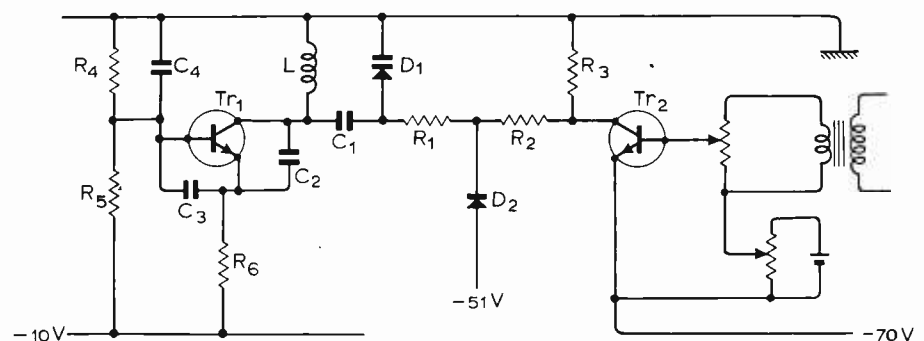

Fig. 1. The heart of the wobbulator is shown here.  $Tr_1$  is a Colpitts oscillator tuned by the varactor diode  $D_1$ . The control voltage for this is applied through  $R_1$  from the collector of  $Tr_2$ ; this produces an output which is the exponential of its input, its base-emitter path acting as the diode of Fig. 3 (b).

\*Editor-in-chief, *Wireless World*

The oscillator circuit itself must have a capacitance which can hardly be much under 12pF and it is necessary to have a blocking capacitor in series with the varactor to permit the application to it of a control voltage. This cannot be very large without causing excessive phase shift in the control voltage, and 330pF is a reasonable compromise. These two capacitance ratios greatly reduce the total capacitance ratio available for a given control voltage swing.

It is, moreover, impracticable to swing the diode to 60V, for this is a maximum rating and it is not possible to operate at this voltage and at the same time guarantee that it will never be exceeded. The varactor is an expensive component and it is necessary to limit the voltage applied to it. Referring to Fig. 1, this can be done by a diode  $D_2$  returned to a zener diode stabilized supply of  $-0.51V$ . The tolerance on the zener voltage is  $\pm 5\%$ , so the voltage is anywhere between 53.55V and 48.45V. At full conduction the forward drop across  $D_2$  may be 0.8V, so the maximum voltage which can be applied to the varactor  $D_1$  is 54.35V, which leaves about 5V factor of safety. The maximum control voltage which can be applied to the varactor with a low limit zener is 48.5V.

At the other end, it is not necessary to limit the minimum control voltage to 4V, but the minimum voltage must not be so low that the varactor can conduct appreciably on the peaks of the r.f. waveform. The normal amplitude of oscillation is about 1.5V r.m.s. or some 2.1V peak. Appreciable conduction in a silicon diode does not usually occur until the anode is more than about 0.25V positive to the cathode. This means that a minimum reverse voltage of  $2.1 - 0.25 = 1.85V$  is possible. Calculation shows that with 12pF oscillator capacitance and 330pF in series with the varactor, the total capacitance at 1.85V is 45pF and to obtain 22.5pF (2:1 ratio) 29V bias is needed on the varactor. On the other hand, at 48.45V the capacitance is 20.5pF, and to obtain 41pF, 2.9V is needed.

Thus, for the assumed capacitance values a 2:1 capacitance ratio is obtainable for a control voltage change of 1.85V to 29V, (27.15V swing) or from 2.9V to 48.5V (45.6V swing). The maximum possible capacitance swing is from 20.5pF at 48.5V to 45pF at 1.85V, or 2.2:1, with a voltage swing of 46.75V. There is thus a reasonable latitude for component tolerances.

The swing required for the control voltage varies greatly for quite a small change of maximum capacitance, for 45pF it is 27.15V whereas for 41pF it is 45.55V. In practice, there are three variables involved, the coil inductance, the peak-to-peak control voltage of the varactor and a mean bias voltage. The latter two are adjusted to obtain the required frequency range, in conjunction with  $L$  and then finally  $L$  is adjusted in small steps, each time with readjustment of the other two variables for the proper frequency range, until linearity is secured.

By this is meant a linear relation between frequency and the displacement of the

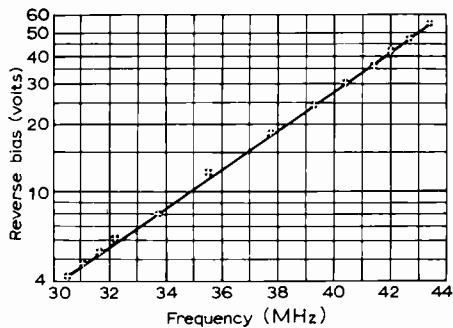

Fig. 2. Measured oscillator frequency plotted against control voltage on the varactor diode. The points nearly all lie on a straight line, showing that the relation is almost perfectly logarithmic.

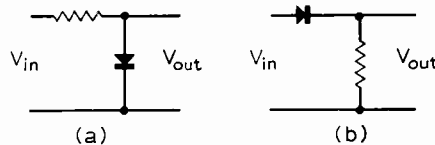

Fig. 3. The use of a resistor and diode to obtain an output voltage which is the logarithm of the input is shown at (a), while the arrangement to obtain an output which is the exponential of the input is shown at (b).

spot on the screen of the c.r.o. The law connecting oscillator frequency with control voltage on the varactor is apparently very complex, but it turns out experimentally to be very simple, at least over the range of interest. Fig. 2 shows a measured curve relating frequency and voltage and it can be seen that the frequency is almost exactly proportional to the logarithm of the voltage. This is very fortunate for a logarithmic relation is one of the easiest non-linear functions to generate.

There are two possible lines of attack. One is to use any convenient control voltage for the varactor and to produce from this voltage another voltage, for the sweep, which is the logarithm of the first. The other is to use any convenient voltage for the sweep and to generate from this another voltage which is the antilogarithm (or exponential) of the first for application to the varactor.

In both cases the waveform alteration can be effected by a junction diode. If the current is kept small, the current is proportional to the exponential of the voltage across the diode and conversely, the voltage across the diode is proportional to the logarithm of the current.

The relation between current  $I$  and voltage  $V$  is actually

$$I = I_s (e^{Kv} - 1)$$

where  $I_s$  is the reverse saturation current and  $K$  is a factor which is temperature dependent and has a value of about 40 reciprocal volts. The inverse relation is

$$V = \frac{1}{K} \log_e (1 + I/I_s)$$

When the current exceeds a few milliamperes the voltage drop across the ohmic resistance of the semiconductor and its contacts starts to be comparable with the

voltage of the formulae and the law is consequently modified. At high currents the current-voltage relation tends to linearity.

Below a few milliamperes (the exact current depends on the particular type of diode) the exponential relation holds very accurately until the exponential term ceases to be large compared with unity. This is when the diode is approaching cut-off.

To produce a voltage which is the logarithm of another voltage the voltage is applied to the diode through a high series resistance and the output is the voltage developed across the diode, as in Fig. 3 (a). If the voltage drop across the resistance is very large compared with that across the diode, the current through the resistance and the diode is almost proportional to the applied voltage and so the output voltage is almost proportional to the logarithm of the applied voltage.

The practical difficulty is that the change of voltage across the diode is very small, probably no more than 0.2V, and more likely some 0.05V. The X-input of a typical oscilloscope is some 9V peak-to-peak, so an amplifier of at least 45 times gain, and more likely 180 times, is required and must be highly linear.

With the second method an arbitrary sweep voltage is used and some small fraction of it is applied at low impedance to a diode. The diode current is then the exponential of the voltage. A very low resistance in series with the diode enables the current to produce a similar voltage, Fig. 3 (b), which can then be amplified to produce a voltage change of about 47V to control the varactor.

This actually works out much better because the base-emitter path of a transistor can be used as the diode so that the diode current is the base current of the transistor and the collector current is the base current multiplied by the current amplification factor.

Suppose a transistor is used with a 200-kΩ collector load. A maximum change of some 47V across this is wanted, so the change of collector current is  $47/200 = 0.235mA$ . If the current amplification factor is as small as 20, the change of base current is  $0.235/20 = 0.01175mA = 11.75\mu A$ . Since the output required is a voltage change of 47V the collector supply voltage must be greater, say 70V. This in turn rules out the possibility of using most transistors. However, there are types rated for 100V and even more, notably types designed for operation in video output stages.

The use of a transistor immediately solves the problem of coupling the current output of a diode to an amplifier. The need for a low impedance voltage feed also turns out to be not too difficult. Because the base current is so small, the source impedance feeding the transistor need be no lower than about 2kΩ. It is not, of course, possible to stabilize the base bias against temperature changes, because the use of an emitter resistance is inadmissible. The input would no longer be applied between base and emitter, but to the input of a feedback amplifier and the desired expon-

ential relation between input and base current would be seriously affected. In theory one could by-pass the emitter resistance, since the input will be some form of repetitive voltage (actually 50Hz sine-wave). It is however, very difficult to do so adequately.

What happens in practice, is that a rise of temperature shifts the oscillator frequencies to lower values. The response curve displayed on the oscilloscope drifts to the left. The drift is quite slow and may amount to a few MHz in normal operation. It can be corrected manually by adjusting a bias control, which is needed in any case to set up the proper operating conditions.

The heart of the wobulator thus comprises a frequency-modulated oscillator

and a wave-shaping stage to provide a linear scale of frequency on the display. The general form of this part of the circuit is shown in Fig. 1. The oscillator is  $Tr_1$  and is of the Colpitt's type;  $C_2$  is made 6.8pF plus the collector-emitter capacitance of the transistor, which is 1.5pF. The other capacitor,  $C_3$ , is 82pF plus the 20 pF base-emitter capacitance. The effective capacitance ratio is thus  $102/8.3 = 12.3$  so that in effect the base is well tapped down the tuned circuit.

The base is earthed to r.f. through  $C_4$ . The inductance  $L$  is in the collector circuit and has in shunt with it the capacitance of  $C_2$ ,  $C_3$  and  $C_4$  all in series. This amounts to 7.5pF. Also in shunt with  $L$  is the varactor diode  $D_1$  in series with  $C_1$  of

330pF; this capacitor is needed to prevent  $L$  from short-circuiting the frequency control voltage, which is applied through  $R_1$  and  $R_2$ . Its presence slightly reduces the capacitance available from the varactor. The amplitude of oscillation is controllable by the supply voltage to the stage, which is shown in Fig. 1 as a nominal 10V, but it is also controllable by the base voltage, which means the values assigned to  $R_4$  and  $R_5$ . These resistors, with  $R_6$ , provide the usual stabilizing network for temperature effects in  $Tr_1$ . The emitter resistance  $R_6$  is, for r.f., effectively in shunt with the base-emitter path of the transistor. The transistor itself has a base input resistance of about 1.2k $\Omega$ . Taking  $R_6$  into account the effective base input resistance is about 550 $\Omega$  only. This is one reason for the high ratio of  $C_3$  to  $C_2$ .

With a supply of 5.5V the oscillator will produce about 0.8V r.m.s. output, and with 10V it gives some 1.5V r.m.s. The output is taken off by a small coil coupled to  $L$  and not shown in Fig. 1; quite loose coupling is necessary and it is hard to secure more than 100mV useful output. This is one limitation of the varactor. The minimum bias on the varactor restricts the voltage obtainable across the tuned circuit and so the maximum output of the whole wobulator.

The wave-shaping stage is  $Tr_2$ . This is simply a transistor with a high load resistor  $R_3$  (220k $\Omega$ ) and its output is applied to the varactor through  $R_1$  and  $R_2$  of 330k $\Omega$  each. Its base is fed by 50Hz from a winding on the mains transformer and also with a d.c. bias. These are merely sketched in in Fig. 1. In practice more complex networks are used because the magnitudes of the voltages required are quite small. The a.c. needed is only around 60mV, while the d.c. has to be variable only over a similar range.

One peculiarity of the circuit must be noted. Two supply voltages are needed, one of some 70V and the other of some 17V and they must have a common positive. This is very unusual for n-p-n transistors, and it arises because of the varactor. It is almost essential to use direct coupling between the wave-shaping transistor and the varactor, because otherwise the two elements would each need variable d.c. bias controls and their proper adjustment would be difficult. Also, an a.c. coupling would introduce appreciable phase shift which would probably be difficult to correct, because the waveform at this point is not sinusoidal.

While it is not necessarily impossible to arrange matters so that the negative supply lines are common, it is much easier to use common positive lines. There is, of course, no objection at all to this apart from the fact that most people are accustomed to thinking of the negative line as the earthy one.

With proper design and adjustment the arrangement of Fig. 1 produces a linear relation between the base voltage of  $Tr_2$  and the frequency generated by  $Tr_1$ . In some measurements a frequency marker, of which more anon, was varied in steps of 0.5MHz from 30.5 MHz to 42.5MHz and the displacement of the marker on

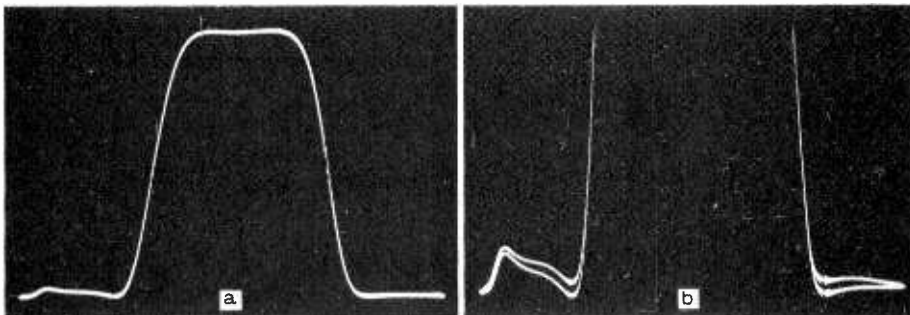

Typical vision i.f. response curve with markers at 34.5MHz and 39.5MHz (a). These markers do not show well in the photograph but are easily seen on the c.r.o. because a beat effect gives them movement. The second photograph is identical but with the c.r.o. gain increased about 10 times and Y-shift applied to show the effect of the trap circuits. The markers at 33.5MHz and 41.5MHz are visible (b). There is a double trace on the skirts due partly to mains hum and partly to the input coupling time constant (0.25s) of the oscilloscope.

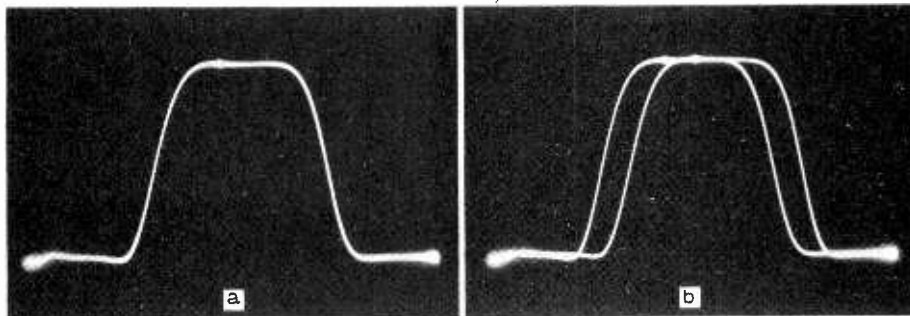

Here the marker is at 36.5MHz (a) and in (b) the phase control has been deliberately misadjusted to illustrate the effect.

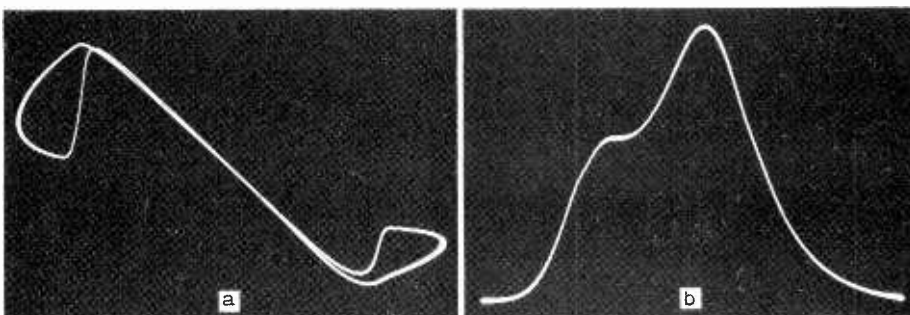

These photographs were taken with outputs from the sound channel. At (a) the output was taken from the a.f. output point; at (b) it was taken via a rectifier probe from the collector of the last i.f. stage. The circuit was not returned to correct for the probe capacitance.

the trace was measured using the calibrated X-shift control of the oscilloscope. The calibration of this control was not checked. There were also, of course, the usual setting and reading inaccuracies of the controls.

As one would expect, therefore, when the points were plotted on linear scales of frequency and marker displacement no straight line could be drawn through all of them. However, the maximum displacement of any point from a straight line drawn between 30.5MHz and 42.5MHz was 0.3% only. One would, in fact, be satisfied with an error of 1%, or even more.

A linear relation between frequency and displacement is one essential. Another is that the amplitude of oscillation should be the same at all frequencies. It does not matter at all if the amplitude varies slowly with time, temperature or voltage, but for an undistorted response curve it is necessary that the amplitude be independent of frequency. The basic oscillator of Fig. 1 does by many standards provide a fairly constant amplitude. The output varies by about 1dB over the band, but this is not good enough.

In actual fact, it is not essential that the output be constant over the whole frequency range. Where constancy is important is over the range of frequencies lying between the  $-6$ -dB points of the passband of the amplifier under test. With television amplifiers these will never be more than 5.5MHz apart and in practice, constancy of amplitude between 39.5MHz and 34MHz will suffice. The shape of the response within the pass-band will then be accurately depicted. Outside the pass-band the response falls rapidly and quickly reaches  $-25$ -dB to  $-50$ -dB levels, an odd dB or so extra variation due to the instrument is there trivial and probably quite undetectable on the display.

Nevertheless it has been thought desirable to include a measure of stabilization. The output of the oscillator is fed to a diode detector and the output of this is fed to a single-stage d.c. amplifier which controls the base voltage of the oscillator. There is thus a negative feedback loop. The loop gain is not high because the detector efficiency is low and the gain of a single stage d.c. amplifier is also low if it is stabilized against temperature changes. It is sufficient, however, to keep the amplitude reasonably constant.

It is essential to have at least one frequency marker. The usual procedure is to couple the output of a signal generator loosely to the oscillator. Its output then passes with the f.m. signal through the i.f. amplifier under test and a beat between the two signals is produced in the detector of this i.f. amplifier. Assume that the marker is set at mid-band, 36.5MHz. The difference frequency is 6MHz when the oscillator is at 30.5MHz, but as this frequency is outside the passband of the i.f. amplifier it is not appreciably passed. When the oscillator reaches 34MHz, however, this frequency will usually be passed appreciably and the beat produced in the detector will be 2.5MHz. As the frequency increases, the beat frequency falls and its amplitude increases. At exactly the

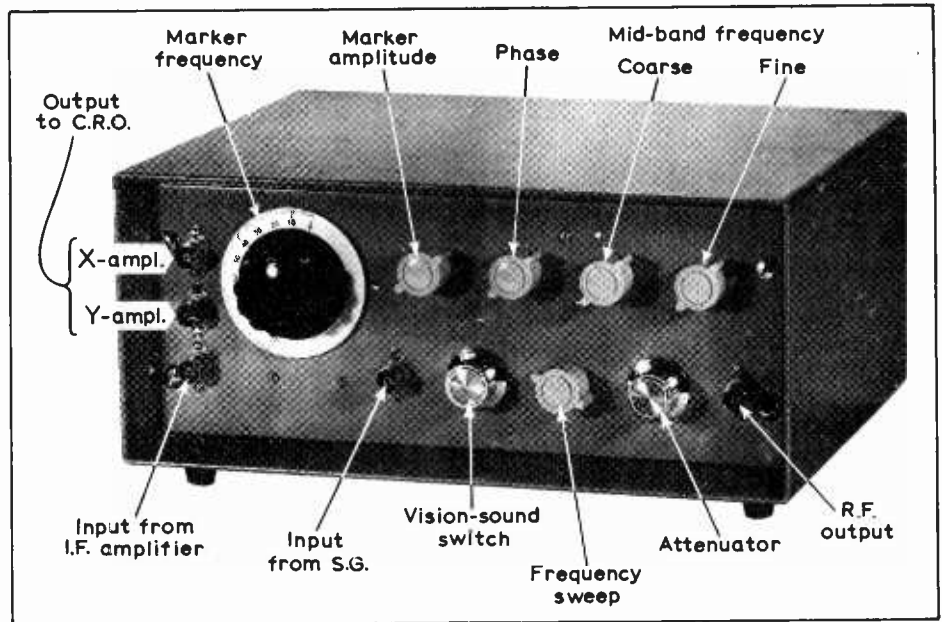

The completed prototype, showing the layout of the controls.

marker frequency the frequency and amplitude drop to zero, but the beat frequency is produced again when the oscillator becomes higher than the marker frequency. Instead of the trace on the oscilloscope being a line drawing out the response curve, therefore, it is wobbled vertically about this line by the beat frequency.

A marker with a total width of some 5MHz is much too wide, of course, and a simple RC filter is included between the detector of the i.f. amplifier and the oscilloscope to restrict the bandwidth to about 0.5MHz at most. The appearance of the marker is then of a narrow blip on the trace, the centre of which gives the true frequency. In practice, there is usually a gap in the centre. In some cases, the width of this gap can be considerable, and this is undesirable. It arises because when the frequencies are nearly alike one oscillator pulls the other into synchronism and the two move together at zero beat until the natural frequencies become too far apart for the lock to hold. If both forward and return traces are presented on the screen, which can be done with a sinusoidal sweep, and the two are phased so that the two traces of the response curve coincide, then when oscillator pulling is present the two marker blips will not usually coincide. This is because two oscillators, once they are locked, normally hold in synchronism over a wider range of frequencies than the band over which one can capture the other. This means that when a gap appears its mid-point is not at the actual frequency of the marker.

A certain amount of locking around zero beat is not uncommon but it is not important as long as the gap between the two halves of the blip is small.

A major disadvantage of this form of marker is that with a constant amplitude of signal from the marker generator it is possible to obtain a reasonable marker blip only between the  $-6$ -dB points of the amplifier. If it is desired to use a marker on the skirts of the curve, the marker disappears because its frequency is atten-

uated by the amplifier, and the signal from the marker generator must be greatly increased. It does have the advantage, however, that as the marker need be only one-tenth or so of the f.m. signal, its actual strength in the pass-band need be only a few millivolts.

In the equipment to be described in subsequent articles in this series, a somewhat different system is adopted. The marker signal is not passed through the i.f. amplifier. A buffer amplifier of roughly 12-MHz bandwidth at  $-3$ -dB is used and is fed through a simple attenuator with the signal from the winding on the oscillator coil  $L$  of Fig. 1 which feeds the i.f. amplifier. The impedance level at this point is only  $75\Omega$  and the variations of the input impedance of the buffer stage over the band do not seriously affect the oscillator output. The collector load of the buffer is a heavily-damped single-tuned circuit to which a signal generator is loosely coupled for the marker. A diode detector then rectifies the mixture to provide the beat and a simple low-pass filter restricts the bandwidth. This signal is then mixed with the output of the detector of the i.f. amplifier under test in another simple filter.

The marker blip then appears on the trace as before, but with an amplitude which is substantially independent of frequency. What amplitude variations do occur are those caused by the variation of gain of the buffer amplifier and are trivial. The marker appears on the trace independently of the i.f. amplifier.

The deflection due to the marker is, of course, entirely vertical but it is drawn out by the X-deflection to have width. As a result the appearance of the marker is quite different on the sides of the curve from what it is on the near horizontal parts. The sides are nearly vertical and so the vertical movement due to the marker tends to get lost in the near vertical movement due to the response curve. The writing speed of the spot, too, is higher, and the

marker is drawn out over a greater length of trace. When one has become accustomed to it, the marker is quite readable on the sides of the curve, although not so easily as on the flat parts. Unfortunately, there is no simple remedy.

In practice, it is useful to have two markers, which can be set at the two required 6-dB points. Alignment can then be carried out so that the two markers come at the half-height points on the two sides of the curve, the correct shape of the curve between them being judged by eye.

The equipment thus has a built-in marker oscillator. This is a transistor oscillator which is basically the same as that of Fig. 1, but having a variable capacitor for tuning. It is also coupled to the coil of the buffer stage. The second marker is provided by an external signal generator.

The internal marker has a second use in connection with the alignment of the intercarrier sound channel. For this purpose it is connected to feed into the output with the f.m. signal and it is set to 39.5MHz. The f.m. signal has its total deviation reduced from the usual 12MHz to about 300kHz by the sweep amplitude control, and its mid-frequency is set to 33.5MHz by the bias control of  $Tr_2$ , Fig. 1. The f.m. signal then represents the sound channel and the marker oscillator the vision channel. The two signals pass together through the vision i.f. amplifier and a 6-MHz beat between them is produced in the detector, and fed to the intercarrier sound i.f. amplifier. The signal generator can still be used to provide a single frequency marker, but it is probably better to have it around 6MHz and inject its output into some point of the sound i.f. amplifier. What can be done in this way obviously depends greatly on the design of this amplifier.

The use of a 50-Hz sine wave from the mains has been mentioned for the sweep. This is done for its convenience. Two supplies are needed, one for the input to  $Tr_2$  in Fig. 1 and the other for the X-deflection of the oscilloscope. The latter must normally have one side earthed. The supply for  $Tr_2$ , however, must have one side at about -70V. However, apart from this, two windings are really desirable since the phase of one may have to be reversed with respect to the other in order to obtain a trace in which movement to the right represents an increase of frequency.

On one half-cycle the spot moves to the right and the frequency increases; on the next half cycle it moves to the left and frequency decreases. Any phase shift in the complete chain from transformer through the wobulator and i.f. amplifier under test to the Y-input of the oscilloscope, and any differential phase shift within the oscilloscope between the X- and Y-channels, will result in two traces of the response curve being produced displaced side by side. A simple phase-shifting circuit in the feed to the X-plates enables the two traces to be brought into coincidence. This has been found adequate, for any errors produce no more than a slight thickening of the trace along its near vertical sides.

An alternative would be to blank alternate half cycles, but some form of phase-shift control would still be needed to give a rough correction of phase and would be difficult to operate since its effect would visually be much the same as that of the d.c. bias control on  $Tr_2$ .

The use of both traces also has its advantages since it can give an indication of some amplifier faults. If non-linear circuits are involved, as they are in the detector, and will be if there is overloading, then the rise and fall times of the output signal may not be the same. When the oscilloscope spot is moving to the right on one half-cycle a rise time is operative on the left-hand side of the response curve and a fall time on the right, whereas on the other half cycle the rise time is operative on the right and the fall time on the left. Therefore any difference in the response to rising and falling outputs will make it impossible to obtain complete coincidence of the two traces.

## Corrections

"Sinusoidal Oscillator for High Temperatures" (July 1970). Pin 1 of the 701C op.amp. should, in addition to the connections shown, be joined to the 0V line.

"Integrated Circuit Stereo Pre-amplifier" (July 1970). In Fig. 3 there are three mistakes: the wiper of  $S_{1b}$  is in the wrong position relative to  $S_{1a}$ ;  $S_2$  should have the lower contact ( $M$ ) joined to the wiper of  $S_{1b}$ ;  $R_{12b}$  should be 12k $\Omega$  not 120k $\Omega$ . On p. 315 in the components list  $VR_{3a, b}$  and  $VR_{4a, b}$  are 100k $\Omega$  + 100k $\Omega$  linear pots.

Communications Receiver (June issue). On page 310 the Racal RA1220 frequency stability should have read, one part in 10<sup>7</sup> per day.

On page 303 (New Products) in the June issue, the illustration shown under the heading D.I.L. Reed Relay should have appeared with the note on the Reed Microswitch (WW 329).

## Souriau Lectropon Transistors

Souriau Lectropon Ltd. apologize to readers for the delay in supplying transistors, which has occurred because of problems in obtaining sufficient supplies from the manufacturers. The company say they undertake to deliver all transistors promptly as there are now sufficient stocks on their premises.

# H.F. Predictions —August

The Greenwich sunspot number for June is 117, indicating a slight decline in the high level of solar activity since March of this year. This decline is not rapid and frequency usage over the next six months should be the same as for the corresponding months of 1968/69 and 1969/70.

Disturbances which have developed this year are expected to continue at the same level for the next twelve months. With regard to the charts the trans-equatorial routes have highest MUFs during equinox months and the values shown should be the highest for the next ten years.

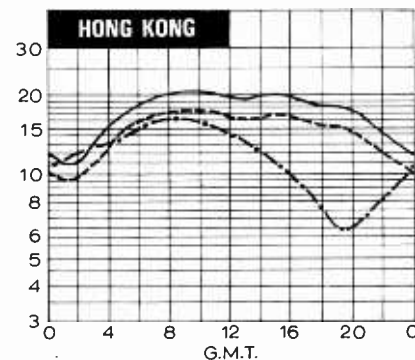
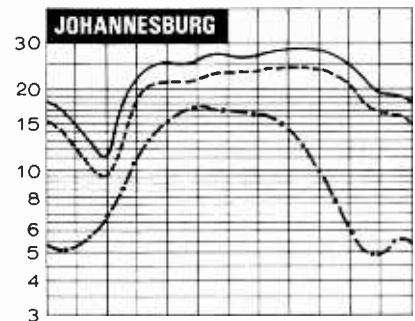
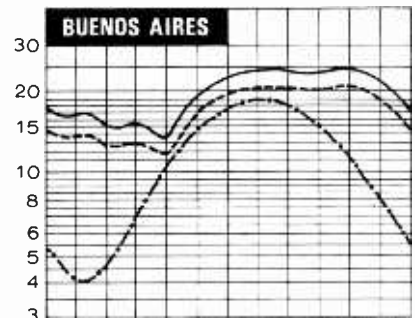
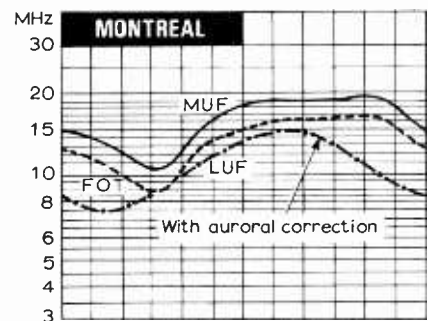



# The Video Disc

## Vision programmes on 'gramophone' records

by J. C. G. Gilbert\* F.I.E.R.E.

The 24th June 1970 will become another important date in the history of the development of television, for on this day the world's first television recording on a "gramophone" record was demonstrated in Berlin. Although the equipment will not reach the public for another 18 months, technical information was released this year as it coincides with the 80th anniversary of the invention by Emil Berliner of the first flat record. Perhaps one should not forget the early experiments of Baird, in which he recorded the B.B.C. 30-line transmission on a standard 78 r.p.m. record and the sound on a separate record.

Teldec is a research and development organization jointly owned by Decca in the U.K. and AEG-Telefunken in Germany. Since 1965 four German scientists headed by Horst Redlich, in conjunction with Arthur Haddy, the chief engineer of Decca Records, Ltd., have patiently developed a video recording system that will make a considerable impact on the educational, advertising and domestic entertainment fields.

Research teams throughout the world are currently working on methods of recording video information, and some demonstrations and technical information have been given to the public. In the U.S.A. the Columbia Broadcasting System has developed the EVR system (see p.366) the RCA Corporation the Selectavision system, Ampex in the U.S.A. video recording on magnetic tape, and there are other methods using photographic films. The table indicates the performance of each type.

In comparing the various systems note that only video tape and Super-8mm film allow the user to record his own programmes, while EVR, Selectavision and Teldec video disc limit the user to purchasing or hiring already recorded programmes; and of these only the Teldec video disc enables one to quickly locate any particular section of a programme. Also, in some systems it is not possible to show a stationary picture or a slow-motion picture. In the Teldec system each complete television picture (two frames) can be shown separately, and by stopping and starting the mechanism one

can show a sequence of individual pictures.

In any form of storage system, whether it be film, gramophone record or handwriting, it is necessary to arrange for a transient flow of information to be recorded and at a later time for the information to be displayed or reproduced. In sound recording the flow of information is at a rate of approximately  $3 \times 10^5$  bits per second, and a normal  $33\frac{1}{3}$  r.p.m. gramophone record has a data storage capacity of about 5,000 bits/mm<sup>2</sup> while a magnetic tape has a data storage

capacity of about 1,000 bits/mm<sup>2</sup>. To store electrical picture information it is necessary to accommodate the information at a density about 100 times that required for a sound recording, the information flow rate being of the order of  $3 \times 10^7$  bits per sec. The first problem therefore is to devise a storage system capable of handling a greater information density, and then to develop a method of reproducing that information.

The Teldec video disc will allow a recording density of upwards of 500,000 bits/mm<sup>2</sup>, or about 100 times the storage capacity of an audio record, and this is equivalent to a signal frequency of 3-4 MHz.

Fig. 1 and the photographs show the principle of the reproducer. The disc is made from thin plastic foil and is rotated at a speed of 1,500 r.p.m. for a 50-Hz mains supply and 1,800 Hz for a 60-Hz supply. The disc is located on a very accurately machined boss and positioned by three pins. It will be seen from the photograph that the disc while stationary follows the contour of the fixed playing desk, and that this is curved and the apex of the curve is just under the reproducing stylus. Concentric with the rotating central boss is an annular slot through which air is forced and then exhausted at the periphery of the disc. Thus when the disc

	Video tape	EVR	Selectavision	8mm film	Teldec video disc
Resolution	250 lines 3MHz	300 lines 4MHz	250 lines 3MHz	250 lines 3MHz	250 lines 3MHz
Signal/noise ratio	> 40dB	> 40dB	> 40dB	> 40dB	> 40dB
Sound recording	Separate track	Separate track	Separate track	Separate track	Combined tracks
Playing time	approx. 60m	2 x 25m 25m colour	approx. 60m	approx. 30m	9in. 5m 12in. 12m
Recording media	Magnetic tape	Special film	Plastic tape	Super-8 film	Plastic foil
Playing time v. copying time	< 50	< 50	< 50	< 50	> 1,000
Material cost for one hour playing	approx. £12	approx. £12 colour £24	approx. £2 5s	approx. £24	less than £1 2s 6d
Pickup device	Magnetic head	f.spot scanning	Laser and vidicon	f.spot scanning	Ceramic p.u.
Reproducer cost (approx.)	£230	£350	£175	£230	£60-£115

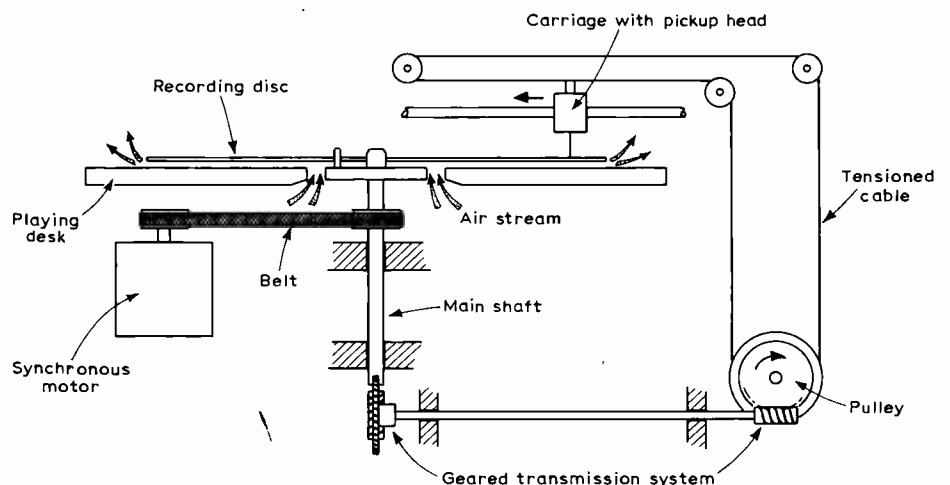

Fig. 1. Principle of the video disc reproducer mechanism.

\* Head of Department of Electronic and Communications Engineering, Northern Polytechnic.

rotates it floats on a very thin air cushion and follows the contour of the curved platter.

The boss and shaft are belt-driven from a small synchronous motor which also drives a reduction gearbox. Attached to the output of the gearbox is a pulley which drives an endless tensioned cable. The pickup head is mounted on two parallel bars, and it is smoothly drawn across the disc by the tensioned cable. The video disc is a remarkable development, for in order to have a playing time of 5 minutes on a 9-inch disc, or 12 minutes on a 12-inch disc, the groove spacing is minute, there being between 120-140 grooves per millimetre, and each revolution of the disc represents one complete television picture. The recording method is hill-and-dale, and one photograph shows a comparison between a normal stereo audio recording groove (on the right) and the frequency modulated video disc grooves that occupy an equivalent space (on the left). The accompanying sound is recorded during the blanking interval, using a pulse position modulation system. It is of interest that the groove on a 9-inch disc is about 3km long.

The pickup head that is mounted on the linear tracking bars carries a very fine tube, at the end of which is a microscopic diamond stylus—Fig. 2. Directly connected to the diamond is a piezo electric ceramic transducer which has an

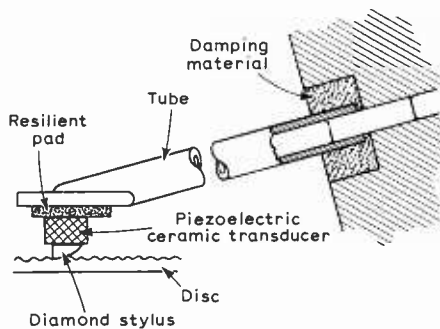

Fig. 2. Details of the pickup, showing stylus and transducer at the end of the fine support tube. The arrangement provides elastic suspension.

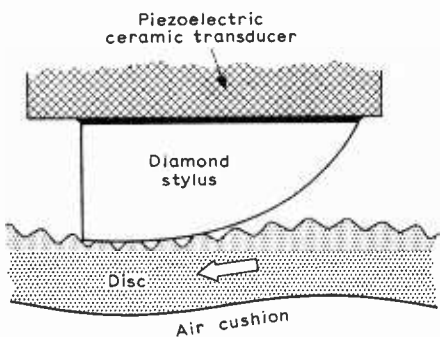
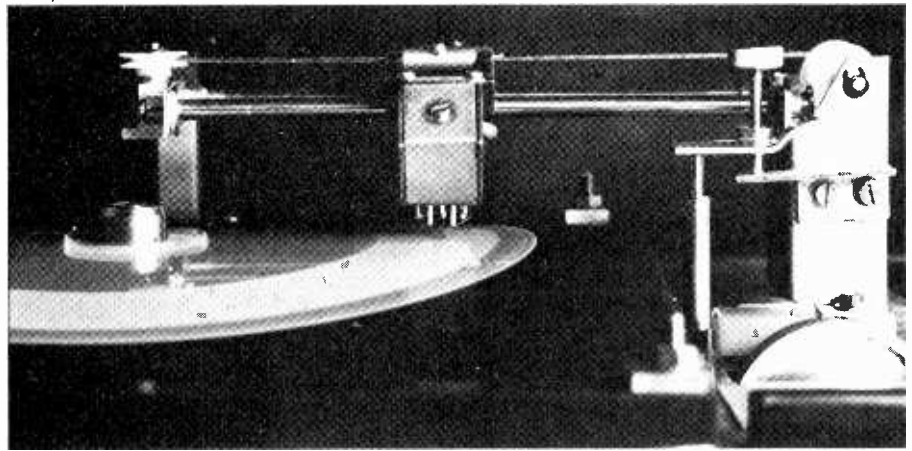

Fig. 3. Cross-sectional side view of the stylus (viewed along a radius of the disc), showing how the disc track is locally deformed where the disc is pushed up to the stylus by the air cushion. The stylus responds to the instantaneous load relief that occurs as the track passes the rear vertical face.



Reproducer mechanism, showing pickup carriage being drawn across disc by the tensioned cable. The convexity of the playing desk, taken up by the flexible disc, can just be seen.

output of about 2mV, and the complete transducer can be seen suspended below the carrying head. The transducer is pressure operated, and, whereas in a normal audio system the record carries the weight of the pickup cartridge, in the Teldec machine the stylus is fixed in position and the video disc is floated up to it on the air cushion. A side view of the diamond stylus, Fig. 3, shows that it is gently radiused in front of the trailing vertical face, and as the disc glides below the stylus, the stylus purposely deforms the hill and dale track which, when it passes the stylus, immediately springs back to its original shape. Thus several bits of information are simultaneously presented to the pressure transducer. It is claimed that each disc can be played at least 1,000 times before the signal-to-noise ratio falls below 40dB.

When one wishes to display a stationary picture a press button on the deck can be operated to disengage the pickup drive cable. As the groove is very shallow the stylus jumps the wall separating the grooves and repeats each complete picture as often as desired. Obviously during such a display there is no speech output as this is integral with each line. The wear of the disc is negligible and even after one has repeated a stationary picture for several hours there is no noticeable visual distortion. While slow motion is not possible in the true sense, it is possible to show complete pictures in slow sequence by operating the press button at regular intervals.

The obvious question is "how well does it perform?" Those fortunate enough to witness this world premiere were astonished at the fidelity of the pictures seen on a multiplicity of television monitors. At present the output from the reproducer is at video frequency, but for the domestic market the unit will embody a modulator so that the signal can be sent over cable to the aerial input of any domestic television receiver. The quality of the black-and-white signal is comparable in definition with the B.B.C./I.T.A. 405-line system although the picture is transmitted on 625 lines. It is confidently expected that colour video discs will be

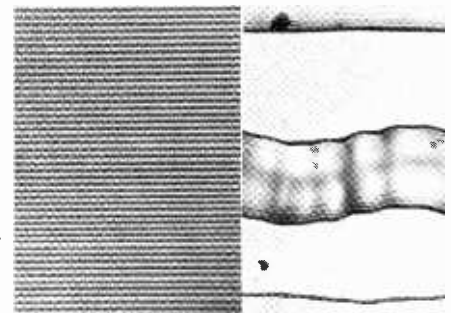

A single groove of a normal stereo gramophone record (right) compared in size with the closely packed grooves of the video disc (left) which register information by a frequency modulated carrier, hill-and-dale, recording technique. The carrier wavelength on the video disc varies with the video signal amplitude.

available a few months after the release of the black-and-white discs. Demonstrations were given of a number of programmes of an educational and instructional nature, extracts from advertisements, etc. As an example of use, a travel agency might have a selection of discs giving short programmes of "a weekend in Paris", a holiday on the Costa Brava and so on. The possibilities seem endless and AEG-Telefunken even suggest that in the future the daily newspaper might include a disc of the highlights of the previous day's sporting events.

As the video disc is capable of storing information up to 3 MHz while rotating at 1500 r.p.m. one can visualize that a modified system using the same basic principles could be employed for sound recording. At a playing speed of 33½ r.p.m. it should be possible to record up to about 70kHz, and possibly the almost forgotten 16½ r.p.m. speed might come into its own. Using a slow speed, several hours of recording could be achieved on a 9in disc; turntable rumble and anti-skating devices would become a relic of the past. Perhaps the most exciting possibility is the recording of multi-channel stereo programmes—two, three, four or more channels being possible with the Teldec multiplexing system.

# Electronic Morse Keyer

Employs m.o.s. integrated circuits to produce dot-dash and space waveforms with precise mark-space ratios

by C. I. B. Trusson \*, M.Sc., G3RVM, and M. R. Gleason\*, B.Sc.

This article describes the design and construction of an electronic morse code keyer using four m.o.s. logic circuits. The dot and dash waveforms generated by the keyer are defined precisely by means of a two stage counter.

### M.O.S. logic circuits

The circuit diagram of a p-channel m.o.s. inverter is shown in Fig. 1. Using the negative logic convention, with logic 0 input level less than the threshold voltage, the inverter m.o.s.t. is 'off' and only leakage current flows into the load m.o.s.t. The logic 1 output level is then a threshold voltage (plus an increment due to source-substrate bias) from the  $V_{DD}$  supply. With a logic 1 input greater than the threshold voltage the inverter m.o.s.t. is 'on' and the output is pulled to a logic 0 level near 0V. With a  $V_{DD}$  supply of -24V typical logic 0 and logic 1 levels are -2V and -17V. It should be noted that the output resistance in the logic 1 output state is very high and so this level can't be measured with a multimeter.

Where it is required to interface an m.o.s.t. inverter with a bipolar transistor the circuit of Fig. 2 may be used. In the logic 0 output state the inverter m.o.s.t. supplies base current to the n-p-n transistor switching it 'on'. In the logic 1 output state the inverter m.o.s.t. is 'off' and the transistor is 'off' because of the base resistor to  $V_{DD}$ .

A NOR gate is simply obtained by connecting a number of inverter m.o.s.t.s in parallel and a NAND gate by connecting them in series. The circuit diagram of a 3-input NOR gate is shown in Fig. 3 and that of a 3-input NAND gate in Fig. 4. Clearly, the NOR gate only gives a logic 1 output when all inputs are 0 and the NAND

gate only gives a logic 0 output when all inputs are 1. The two gate circuits used in the electronic keyer are the Plessey MP104, a dual 3-input NOR gate and the MP102, a dual 3-input NAND gate. With these circuits, unused NOR gate inputs should be connected to 0V and unused NAND gate inputs should be connected to  $V_{DD}$ .

The keyer also uses two MP106 counter/register/bistable circuits. The MP106 logic diagram is shown in Fig. 5 and its modes of operation will now be outlined. In its synchronous mode S is set at a 1 and data,  $D_0$ , is transferred to  $D_1$  and its inverse to  $D_1$  on the clock pulse transition  $CP_1$  0→1, assuming  $CP_2$  is at 0. In the steady state, with  $CP_1$  at a 0 or a 1, the outputs  $D_1$  and  $D_1$  cannot be affected by any change in  $D_0$ . In this mode the element operates as a shift register. To obtain a binary counter function the  $D_1$  output is connected back to the  $D_0$  input with S held at 1, causing the  $D_1, D_1$  output states to change every  $CP$  0→1 transition. Asynchronous bistable operation is achieved by setting S to 0. The data on the F input is then transferred to  $D_1$  and its inverse to  $D_1$  irrespective of  $D_0$  and  $CP$ .

### Design of the electronic keyer

A morse transmission consists of a series of dots, dashes and spaces. Within a morse character (the code for a letter, number or punctuation) a dot consists of a 1:1 mark-space pulse and a dash a 3:1 mark-space pulse. The waveform of Fig. 6 shows a dot followed by a dash, the code for the letter A. The dot, being the highest frequency component of morse code, is the most difficult for an operator to send and severely limits the maximum speed attainable with a conventional morse key.

The m.o.s. electronic morse keyer allows an operator to send perfect morse characters up to very high speeds by controlling accurately, with a multivibrator, all the periods within a character, i.e. dot, dash and space. In addition, the dot and dash can be made self completing such that the paddle only has to be touched momentarily on the dot or dash side of the key and they are completed automatically, leaving more than the period of a space to move the paddle from side to side.

The dot and dash waveform of the electronic keyer are obtained by gating the outputs from a two-stage MP106 counter

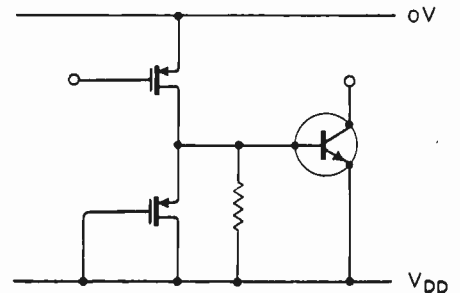

Fig. 2. Connecting a m.o.s. inverter to an n-p-n transistor.

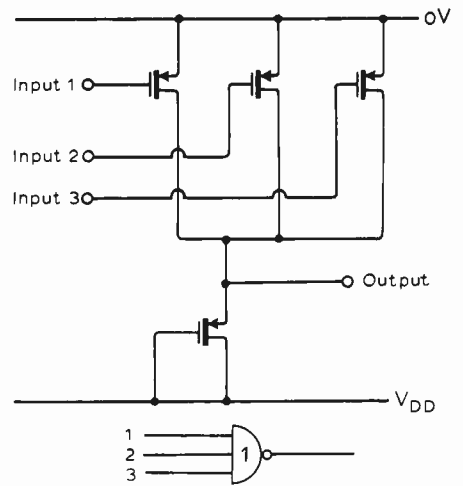

Fig. 3. A three-input NOR gate.

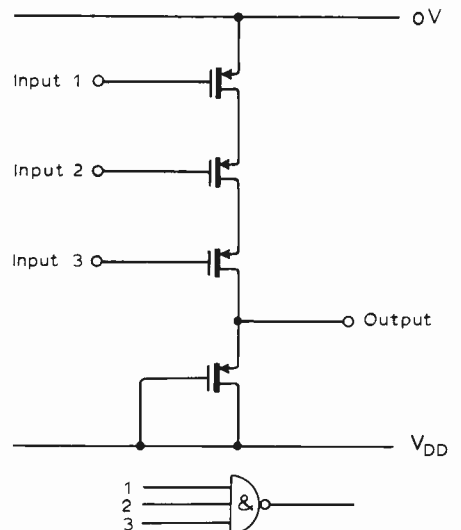

Fig. 4. A three-input NAND gate.

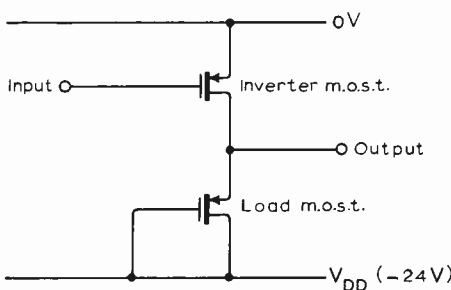

Fig. 1. The circuit of an m.o.s. inverter.

\*Plessey Microelectronics

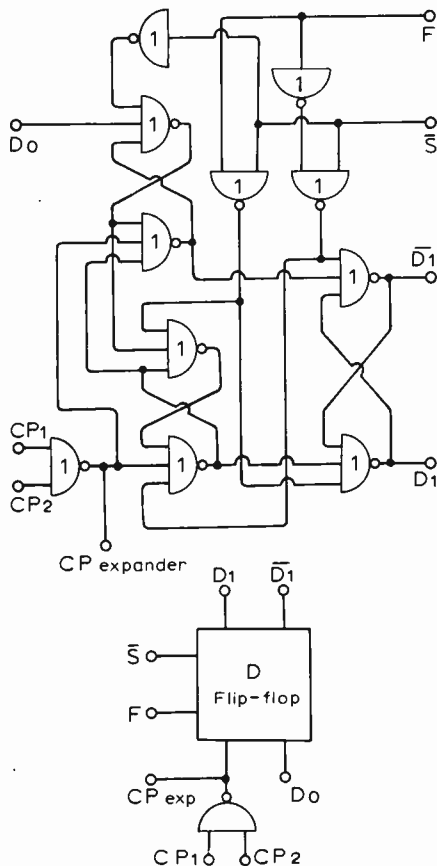

Fig. 5. Counter-register-bistable circuit type MP106.

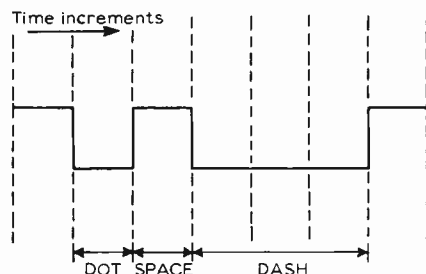

Fig. 6. Morse code waveforms corresponding to dot dash.

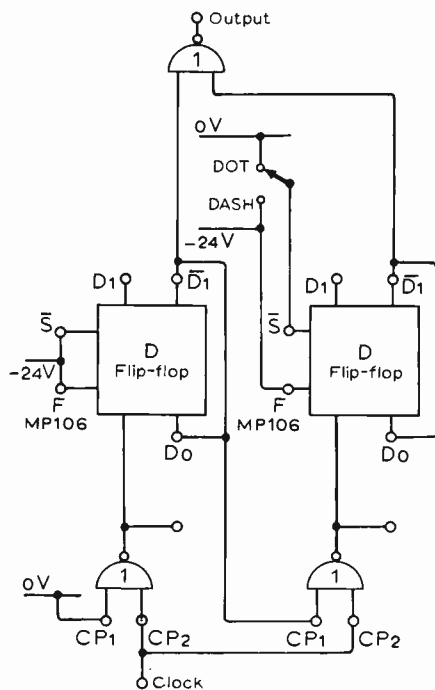

Fig. 7. Dot dash waveform generation.

as shown in Fig. 7. For the dot waveform, the S input of the second counter is set at a 0. This puts the second counter in its asynchronous mode with the data on F, a 1, being transferred to D, and its inverse, a 0, being transferred to D<sub>1</sub>. The first counter has its S input permanently at a 1, and therefore counts with the 1:1 mark-space ratio dot waveform. A 1 at the output corresponds to a space, a 0, a dot.

The dot waveform is obtained from the output of a counter, rather than directly from a multivibrator so that the mark-space ratio is precisely 1:1 at all speeds. The multivibrator providing the clock to the counter does not need an accurate mark-space ratio and, therefore, only a single gang potentiometer is required to vary its frequency. For the dash waveform, the S input to the second counter is set at a 1. Now both counters are operating in the synchronous mode and the four output states at the two D outputs are 00, 11, 01, 10. the NOR decoding gate decodes 00 to give a 1 output which corresponds to a space. In the remaining three states of the counter the NOR gate output is a 0, giving the required 3:1 mark-space ratio dash.

The method of dot and dash waveform generation described above forms the basis of the electronic keyer. In addition a multivibrator is incorporated which is stopped

between characters so that dots and dashes commence immediately the paddle is operated at the start of a new character. Otherwise, with a free running multivibrator, there is always some uncertainty as to when the first dot or dash of a character is going to start. Logic to control the stopping of the multivibrator with the counter in the space state and to provide self completion of dots and dashes is also included.

The functioning of the keyer will now be described in detail. Its full logic/circuit diagram is shown in Fig. 8. Initially, at switch-on, the emitter coupled multivibrator provides clock pulses to the counters until the output of the decoding gate-1 is in the logic 1 space state and the output of the multivibrator has gone to a 0. Gate-4 gives a 0 output which stops the multivibrator in its present state by clamping the 200Ω load to the -24V supply with a saturated n-p-n transistor. When the paddle is pushed to the dot side the output of gate-3 goes to a 0 causing the output of gate-4 to go to a 1. This releases the multivibrator whose output instantly goes from 0→1 clocking the first counter and producing a dot at the output of gate-1. The paddle may then be moved from the dot side since the multivibrator continues until the space state has been reached and the output of the multivibrator is back at a 0. The

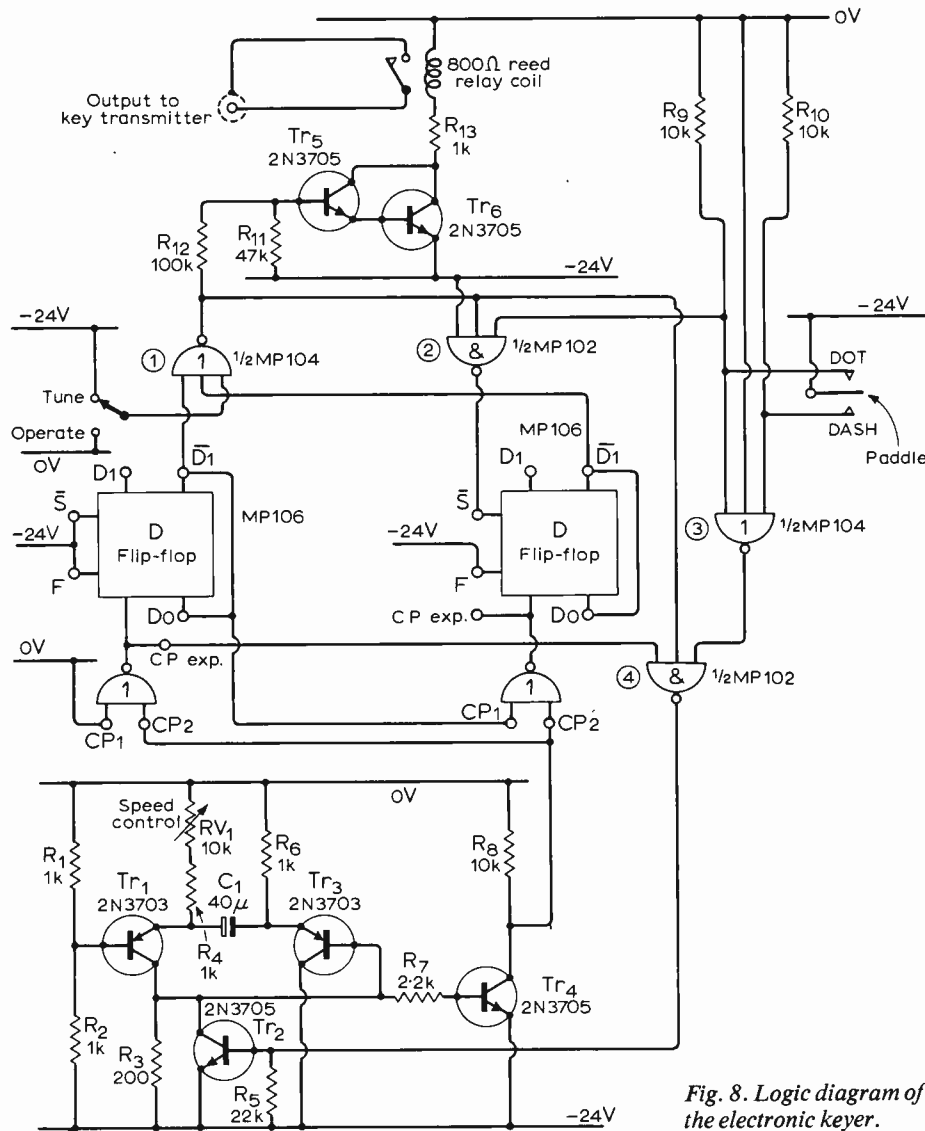

Fig. 8. Logic diagram of the electronic keyer.

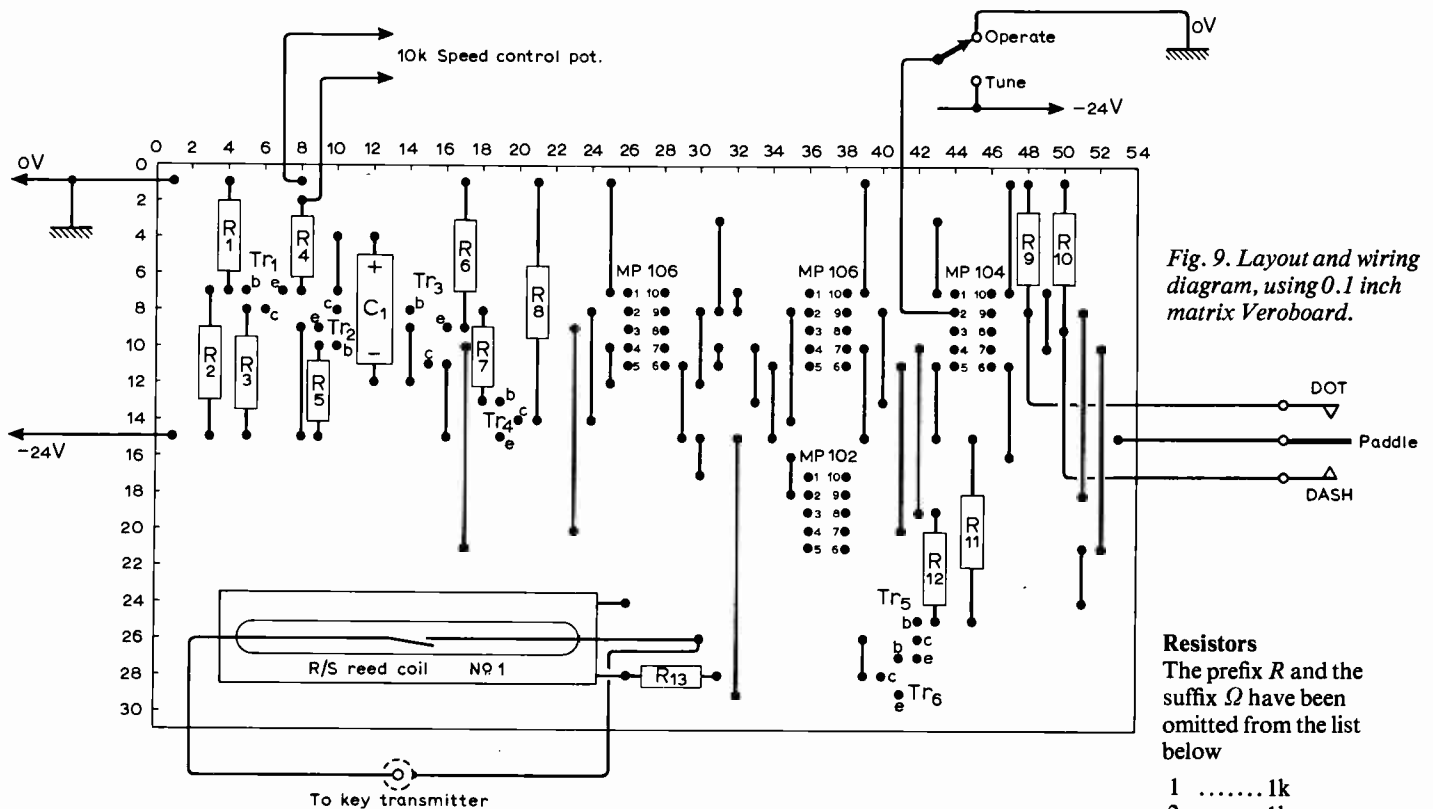
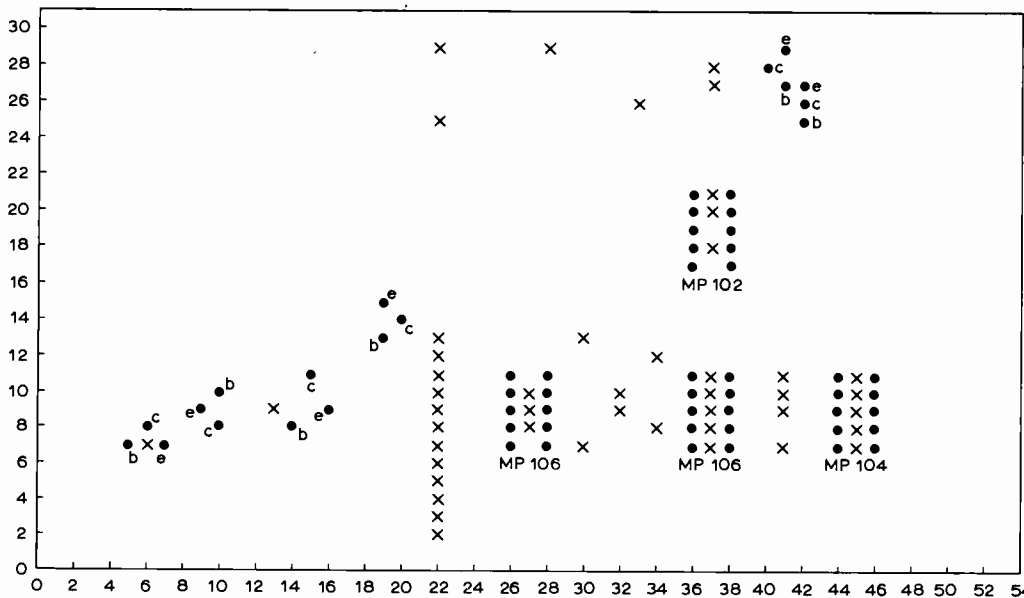

Fig. 9. Layout and wiring diagram, using 0.1 inch matrix Veroboard.

**Resistors**  
The prefix R and the suffix Ω have been omitted from the list below

- 1 ..... 1k
- 2 ..... 1k
- 3 ..... 200
- 4 ..... 1k
- 5 ..... 22k
  
- 6 ..... 1k
- 7 ... 2.2k
- 8 .... 10k
- 9 .... 10k
- 10 .... 10k
  
- 11 .... 47k
- 12 ... 100k
- 13 ..... 1k
- RV1 .. 10k

**Other parts**  
C1 ..... 40μF, 25V  
Tr2, 4, 5, 6, ..... 2N3705  
Gate-2, -4 ..... MP102  
Tr 1, 3 ..... 2N3703  
Gate-1, -3 ..... MP104  
Flip flops ..... MP106



output of gate-4 will then return to a 0 stopping the multivibrator unless the paddle has been transferred to the dash side, in which case the output of gate-4 remains at a 1 and the multivibrator continues. With the paddle on the dash side the output of gate-2 is a 1, setting the second counter in its synchronous mode. The dash waveform is, therefore, produced at the output of gate-1. As for the dot, once the dash has started the paddle may be moved and it is self completing, the S input to the second counter remaining at a 1 until the output of gate-1 returns to a 1, the space state. Strings of dots and dashes within a character are produced by holding the paddle on the relevant side until after the start of the last dot or dash.

Normally the morse key input to a transmitter is intended to be driven by a mechanical key. The output of gate-1,

therefore, is interfaced to a reed relay to drive the transmitter. The 100Ω resistor is included in series with the base of the n-p-n Darlington pair, since a logic voltage swing is required at the output of gate-1 to drive gates-2 and -4. The reliability and contact bounce of a reed relay are both likely to be very much better than that of a mechanical key. However, a preferable solution would be to modify the transmitter to be keyed directly from gate-1.

With an electronic keyer it is not possible to hold the transmitter 'on' continuously for tuning purposes. A 'tune' switch is, therefore, provided which, when operated, sets the output of gate-1 to a 0, holding the reed relay 'on' until the switch is moved back to the 'operate' position. A push button may be more convenient than a toggle switch.

The keyer in use at G3RVM is built on

0.1 in. Veroboard and housed, complete with mains power supply in a 4.5 × 7.25 × 2 inch die-cast box. The Veroboard layout is illustrated in Fig. 9.

The nominal -24V power supply for the keyer does not need to be regulated, the tolerance being -20 to -26V.

The MP100 range m.o.s. logic circuits used in the keyer are available from the Plessey microelectronics distributors: A. C. Farnell Ltd., Kirkstall Road, Leeds 3, or SDS (Portsmouth) Ltd., Hillsea Industrial Estate, Hillsea, Portsmouth, Hampshire.

**REFERENCES**

- 1. MP.100 series Data Sheet.
- 2. Trusson, Ce. I. B., Foss, R. C. "MOSAIC Blocks for System Breadboarding". (Both of these documents should be obtained from the Plessey distributors.)

# News of the Month

## Space-probe to Jupiter

Man's first venture (Mariner) beyond the orbit of Mars into the outer solar system will begin with the launch of two spacecraft, Pioneers-F and -G, in 1972 and 1973 on missions which will last about two years each.

These spacecraft will be the first to penetrate the asteroid belt and will spend about a week orbiting Jupiter with the period of closest approach, and maximum scientific interest, covering about 100 hours. Closest approach is planned to be about 100,000 miles.

One goal of the mission is to assess hazards in deep space and to develop technology and operations experience for missions to the outer planets—Jupiter, Saturn, Uranus, Neptune and Pluto—planned for the late 1970s.

Pioneers-F and -G will be identical spacecraft weighing about 550 pounds apiece and carrying 60 pounds of scientific instruments. Each will be capable of performing 13 scientific experiments in space including photographing Jupiter.

The Pioneers will be powered by four radioisotope thermoelectric generators

producing a total of 120W. The spacecraft will be stabilized in space by spinning at five revolutions-per-minute in the plane of the Earth's orbit so that a nine-foot-diameter directional radio aerial is pointed constantly at Earth.

The thirteen scientific experiments will make a broad study of a number of interplanetary phenomena, possible hazards of flying through the asteroid belt, the Sun's influence on interplanetary space and the penetration of galactic cosmic radiation into the solar system.

They will measure hydrogen atoms; electrons; nuclei of hydrogen, helium and other elements; and the interplanetary magnetic field.

They will gather data on the heliosphere, the region of the Sun's influence on the space environment; and they will look for the boundary where the heliosphere ends and space begins.

Both spacecraft will spend six months to a year passing through the asteroid belt which circles the Sun from 180 to 330 million miles out. The experiments will measure the intensity and polarization of sunlight reflected from asteroids and cosmic

dust to allow calculations of overall quantities of cosmic debris.

Near Jupiter, the Pioneers will gather information on a number of mysteries surrounding the planet. In addition, scientists will perform a celestial mechanics experiment and a radio-occultation experiment by analysing the radio signals from the Pioneers just before and just after they pass behind the planet for about one hour as viewed from Earth. Earth-based studies of Jupiter have not yet revealed whether the surface of the giant planet is solid, liquid or gas.

Jupiter periodically emits huge surges of radio noise. It appears to have a magnetic field of its own, similar in shape to Earth but far stronger, and radiation belts an estimated one million times more intense than Earth's.

The planet is believed to be the only one in our solar system which radiates more energy than it absorbs from the Sun, current measurements indicating about twice as much. If these observations are correct, they show that Jupiter has a very dynamic interior and may have processes at work which are similar to a star's such as our Sun.

## Much smoke at *Which?*

*Which?*, the journal of the Consumers' Association, recently carried out tests on battery eliminators for portable radios and tape recorders. The subsequent report, rather confusingly headed 'Mains Adaptors', told how the transformers of five of the nine units tested broke down when subjected to the tests laid down by British Standards and were labelled potentially dangerous. All five faulty units came from the far east and were the Aiwa AC-603 and AC-606, Eagle products LA-9P and LA-10S and the Sony AC-90E.

Of the four eliminators which were classed as safe, manufactured by Bang and Olufsen, Grundig, Philips and Radionette, the Philips N6502 was chosen as best value for money.

While on the subject of battery eliminators we would like to point out to readers the existence of even more dangerous examples than those tested by *Which?* The type we have in mind are usually very cheap and do not employ any isolating step-down transformer at all. The required voltage drop being obtained by capacitive or resistive means. These units could be lethal. Be warned!

In these eliminators a direct connection exists between the low battery-voltage output and one side of the mains—as in normal mains radio a.c./d.c. practice. The low voltage equipment to be powered by battery eliminators (transistor radios, tape recorders, etc.) are not designed with mains voltages in mind so it is very possible that external metalwork and uninsulated sockets, etc., may be connected to some part of the internal circuitry—probably the common line.

*The pictures show a portable aerial mast which can be erected without the use of tools and without having to worry about loose parts. The masts can be made in aluminium or stainless steel in three diameters from 15 to 25 inches. Packaged they are one-thirtieth of their deployed height which can be up to 100-ft. The Astromast tower, as it is called, is manufactured by the Astro Research Group of California, U.S.A.*

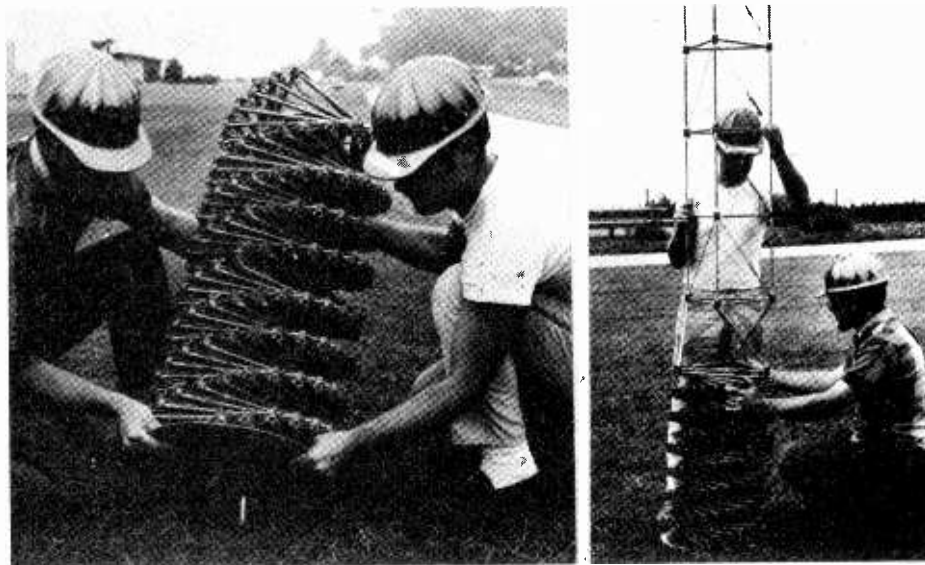



*A 4-metre transmitter powered by a single Mallory mercury cell is being implanted in the rhino's horn, the single-turn aerial will be accommodated in a groove cut around the horn. After implantation the damage is made good with glass fibre and quick-setting resin. The electronic equipment was designed by the Council of Scientific and Industrial Research, Pretoria, in order that they may keep track of individual animals.*

This means that a direct connection exists between this bare external metal and one side of the mains socket, an extremely dangerous situation. Also any external devices connected to the powered equipment, such as tape recorders, extension loudspeakers and earphones, are also likely to become live.

The moral? Do not try to save a few shillings, buy a reputable make at a fair price and satisfy yourself that the circuit arrangements are adequate.

### Push-button telephone chips

In the April issue, in this section, the push-button touch-tone method of dialling was discussed. Pushing a button corresponding to a digit resulted in two tones being transmitted to the exchange for decoding. Push-button dialling is quicker and more convenient than the normal dial we use today, and with the touch-tone system it is possible to use the telephone to switch on equipment, from a remote point, merely by tapping out the required code after connection to the premises has been established.

A major disadvantage of the touch-tone system is the need for additional equipment at the telephone exchange to decode the tones.

The present method of dialling in this country is called the Strowger system. If the digit nine is dialled the telephone transmits nine pulses, one after the other, which are counted by the exchange equipment. A push-button telephone, to be compatible with the Strowger system and not demand any alteration in exchange equipment, must also transmit an identical serial pulse train.

It would indeed be difficult and expensive to design a push-button that, by mechanical means, caused nine pulses to be transmitted when it was pressed. But using digital methods such a task can easily be accomplished. The digit nine can be represented by four binary digits.

Pressing the button nine could result in the four bistables in a counter being set in the condition representing nine. A gating system could then allow pulses to the counter to cause it to count backwards: nine, eight, seven . . . until zero is reached, the gating system could then be arranged to cut off the supply of pulses to the counter. Nine pulses would have been fed to the counter and these could also be transmitted to the exchange at a speed compatible with the equipment in use there.

Similar methods to these are now being used in m.o.s. (metal-oxide-silicon) integrated circuits being produced by Marconi-Elliott and by T.M.C. These circuits store all the digits of a telephone number fed to them by push-buttons and transmit them in serial form to the Strowger exchange equipment.

The logic design for the Marconi-Elliott integrated circuit was carried out by the telephone division of G.E.C. and the chip design and layout was done by Marconi-Elliott Microelectronics.

T.M.C. adopted a different approach and designed the whole thing themselves including the structural details of the microcircuitry.

Both systems consist of two chips the difference being in the interconnections, the encapsulations, the logic design and the number of external discrete components required.

The Marconi-Elliott chips are mounted on the push-button unit to form an integral unit, whilst in the T.M.C. unit two circuit cards are employed in addition to the push-button unit.

The use of these m.o.s. dialling systems does not allow coded information from the push-buttons to be used to actuate external devices as is the case with the touch-tone system. It is said by exponents of the m.o.s. system that this does not matter much any way as any amount of data can be sent along the telephone lines by external equipment once connection has been established. An advantage of the m.o.s. system is that often used numbers could be stored in binary form in a small digital store

(an m.o.s. read/write memory chip) so that these numbers can be dialled automatically on pressing a single button.

Just recently T.M.C. have announced an order for £0.5M worth of their m.o.s. equipment that will be used by operators in telephone exchanges.

### Aerial for 1-3cm communications

Radio communication in the 3cm to 7mm wavelength region, normally used only for radar, is one possibility to be investigated with an unusual steerable aerial mounted on the roof of Birmingham University's new Electrical Engineering building. This region, 10GHz to 40GHz, would accommodate 5,000 television or 7 million telephone channels, but, of course, the waves are subject to atmospheric absorption and propagation is dependent on the weather. Radio meteorology is, in fact, another field of research for which the aerial will be used. Being sited in the environs of a large city, the aerial is surrounded by sources of man-made interference, but this was a deliberate choice, to permit study of communication in the presence of such interference. Apart from terrestrial communications, the aerial will allow research into the possibility of cities and smaller urban communities having their own satellite terminals. (Next year there will be geo-stationary satellites in orbit working in the 1-3cm region.)

Built by Husband & Co. and Markham & Co. Ltd., the aerial is unusual because it has an offset Cassegrain configuration. The main parabolic reflector, which is 20ft in diameter, can be considered as a piece cut out of the side of the reflector of a larger parabolic aerial. Hence the small hyperbolic sub-reflector is not within the beam of the main bowl. This means, for one thing, that the small reflector does not

*The aerial on the roof of Birmingham University.*



obstruct and scatter radiation passing into or out of the main bowl and, secondly, that it does not reflect local interference energy into the receiver.

The cabin can be rotated about the vertical axis to obtain azimuthal motion, while the main bowl support arm and small reflector can be turned about the slant axis, thereby rotating the aerial beam around a cone centred on the slant axis. In this way the beam, which has a width of 12 minutes of arc at 1cm wavelength, can be aimed at any point above the horizon. An advantage of this design is that it reduces the length of waveguide required, and hence losses, from the aerial feed horn to the transmitter or receiver.

Digital position control is used, and for tracking communication satellites there will be an on-line digital computer with a "hill-climbing" optimising control programme.

At present no receiving or transmitting equipment is installed. The first experiments will use radiometers to map noise energy from natural and man-made sources.

## The technology of music

Music is steadily becoming more closely linked with electronic engineering. Whenever a concert or other performance is broadcast or recorded a considerable burden of responsibility falls upon the sound engineer. Realizing this, the University of Surrey, is to start a "Tonmeister" course leading to B.Mus. (Tonmeister). For this course the music department will run in conjunction with the Department of Physics. The declared

aim is to produce graduates who are fully competent in both the technical and artistic aspects of music reproduction. A Tonmeister must therefore be a musical, artistic personality having a well-trained musical ear as well as considerable technical knowledge, and he must be competent in handling microphones, mixers, recorders and other apparatus for sound reproduction. This course at the University of Surrey (Guildford) is due to begin in October of this year.

## Experimental pacemaker

An experimental pacemaker which is powered by electrical energy generated by blood pressure now offers the hope that the thousands of people with pacemakers implanted in their bodies may avoid the need for periodic surgical battery changes. The new pacemaker was devised at Bell Laboratories and the New York Hospital-Cornell Medical Center. Much work remains to be done before the experimental pacemaker can be tested on humans. However, its feasibility has been demonstrated.

A pacemaker is an electronic "clock" about 2.5 inches in diameter which is usually implanted surgically beneath the skin below the shoulder. It produces about 70 electrical impulses a minute which travel down a long electrode wire inserted through a vein (such as the jugular vein) into the heart. These electrical impulses stimulate the heart.

The experimental pacemaker uses piezoelectric discs to convert variations in blood pressure into electricity. A small plastic tube is inserted through a vein into the right ventricle of the heart, following much the same path as the electrode in a conventional pacemaker. At the end of this tube inside the heart is a small 'balloon' filled with water. When the heart contracts and there is a change in blood pressure, the water is squeezed up the tube, producing a mechanical strain in the piezoelectric discs. The piezoelectric material converts the mechanical strain produced by the blood pressure into electricity, which is stored in a capacitor and used to run the pacemaker. Electrical impulses produced by the pacemaker travel down a pair of wires which are wrapped around the plastic tube.

## Industrial information service

Information on the products, services and business structure of nearly 30,000 major U.K. companies is now offered by the Industrial Information Services conducted by Kompass Publishers Ltd., of R.A.C. House, Lansdowne Road, Croydon, RC9 2HE. The source of this information is the computer memory bank used in the compilation of the 2-volume U.K. Kompass Register. Any permutation from various categories of data stored in the



*An historic moment of 50 years ago; Dame Nellie Melba making the first advertised broadcast in this country from an improved studio of the Marconi Works at Chelmsford. This event took place on the 15th June 1920 when Wireless World was about nine years old.*

computer can be extracted and printed to customers' requirements, to provide a precise basis for marketing strategies or, in list or gummed label form, for direct mail operations. Cost of the service varies according to the amount of information required by the client.

## Weather system for the Army

Under a £3M Ministry of Defence contract GEC-Elliott Space and Weapons Division and Plessey are to manufacture an automated meteorological system for use by Army artillery sections. GEC-Elliott will be the prime contractor and will be responsible for the research and development required by the overall system and will supply all the data processing equipment. Plessey, as principal sub-contractors, will be the R&D authority and supplier of the tracking radar and radiosonde sub-systems.

The complete equipment is called AMETS (Automated METEOROLOGICAL System). It consists of an instrumentation vehicle containing the data processing equipment and a small trailer for the radar. Other vehicles would normally be employed as well to function as a command post, to carry stores and to carry out reconnaissance.

In operation a hydrogen filled balloon carrying a radar reflector and radiosonde, which transmits temperature measurements, is released. The computer, an Elliott 920B, receives temperature measurements from the radiosonde, details of the balloon's position and rate of movement from the radar, a measurement of surface atmospheric pressure from the

*A television remote controlled vehicle developed by the Communications Division of America's National Aeronautics and Space Administration. The vehicle simulates a lunar rover.*

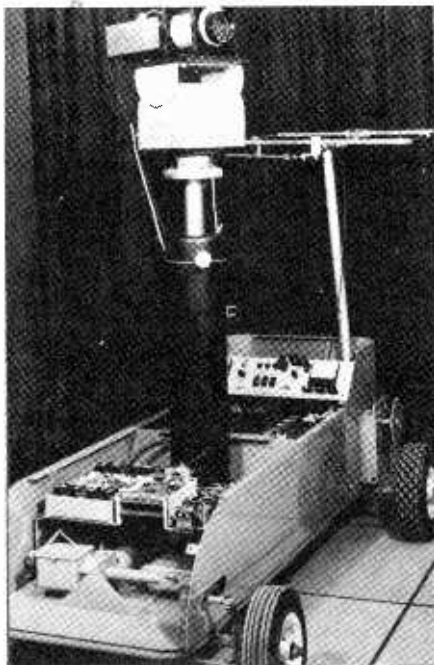



instrumentation vehicle and average humidity figures from its own memory. These figures are fed into the memory prior to the operation and depend on the area in which the equipment is located.

From all this information the computer calculates and prints out the required meteorological message two minutes after the radiosonde balloon reaches the required height. Earlier methods needed far more equipment to be carried by the balloon and the subsequent calculations took about an hour.

### I.E.E.T.E. have a good year

The Institution of Electrical and Electronics Technician Engineers report of the council and accounts for the year ended 31st March 1970 shows that the Institution made further progress and that membership had advanced to nearly 12,000. With the setting up of the Northern Ireland Region in May, 1969, the Institution now has ten regional centres.

### Radar network for Africa

An air traffic control and meteorological radar network, valued at more than £1M, has been ordered from Plessey Radar Limited by the Directorate of Civil Aviation for the East African Community. The network will cover most of East Africa and is part of the modernization programme currently being carried out to re-equip the airports and air traffic control system of Kenya, Tanzania and Uganda.

The hub of the new air traffic control system will be a central area control radar station equipped with an AR-5 long-range radar and an automatic secondary surveillance radar system. These radars will be used for surveillance and control between the three major airports of East Africa: Entebbe (Uganda), Nairobi (Kenya) and Dar-es-Salaam (Tanzania).

Under the contract Plessey will also supply three AR-1 medium-range terminal area radars for Entebbe, Dar-es-Salaam and the new Kilimanjaro international airport.

*A new Ampex video tape duplicating centre at Boeblingen, West Germany. A master tape is played on a VR-1200 and duplicated on eight VR-7003 videotape recorders. Present capacity of the centre is 1000hrs/month.*



### Audio Fair

An innovation at this year's London Audio & Music Fair, which is again being held in Olympia (October 19-24), is the presentation of lecture-demonstrations and concerts in one of the halls four times each day. Full details are not yet available but *Wireless World* has undertaken to put on a series of lecture-demonstrations on the general theme of "what is fidelity in sound reproduction?" These will be given by well-known designers who have contributed to the journal. We hope, as far as possible, to use equipment described in *Wireless World* for the demonstrations. Further details of the lectures and the procedure for obtaining tickets will be announced as soon as they become available.

We understand from the organizers that over 75% of the available space in the exhibition has already been booked by 80 manufacturers and dealers. "Sound-proof" demonstration booths will again be constructed adjacent to the exhibition stands.

### Computer talk

Bell Laboratories engineers in America have programmed a computer to convert printed English text into synthetic speech. Recent experiments take advantage of an improved understanding of speech patterns—the way people really use their language and tailor it to match their intended meaning. Bell researchers gave the computer mathematical approximations of the shapes and motions the human vocal tract assumes when uttering common sounds and sound sequences. They programmed the computer with a basic dictionary of word categories and definitions in digital form. Then they approximated, for computer storage, the complex rules of timing, pitch and stress which people use naturally in everyday conversation.

In the experiments passages are typed and sent to the computer from a

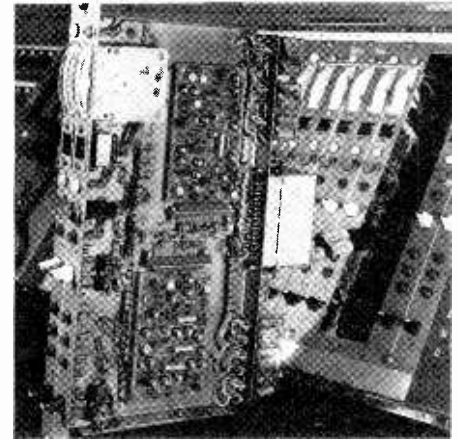

*Under a £73,000 contract International Aeradio has designed and built system control equipment for the control centre of Britain's military satellite system, Skynet, at Oakhanger, Hampshire. The photograph shows a module which forms part of the channel switching console.*

keyboard. The computer analyses the sentence, assigns stress and timing to each word, and finds a phonetic description of each word from a dictionary stored in the computer's memory. Mathematical descriptions of vocal-tract motions are computed. These descriptions are used to generate electrical speech signals which may be heard over a loudspeaker or a telephone. The typed sentence also can be stored in the computer for later use.

An oscilloscope connected to the computer produces a line drawing of the model vocal tract, and displays the change in position of the throat, jaw, tongue, and lips as different sounds are produced. The oscilloscope display, though unnecessary for text-to-speech conversation, aids researchers in monitoring the performance of the system.

### An exercise in circuit maximization

Do you use a sledgehammer to crack a walnut? A circuit recently released by Motorola appears to do just this. The circuit is intended to eliminate component damage in a flashing-lamp warning indicator due to current surges caused by the low cold resistance of lamps. It also prevents any damage due to short-circuits within the lamps.

The engineer who designed the circuit must have had his eyes on the sales figures for he used five transistors, two diodes, one zener diode, four two-input gates, twelve resistors and three capacitors. This did not include the two transistors, two capacitors and four resistors needed for a multivibrator to drive the circuit.

It may be that a single resistor could have been used to keep the lamps warm to offset the low cold resistance problem and a simple ring-of-two constant current circuit may have been enough to cope with lamp short-circuit problems. Never mind, perhaps the report was issued on April 1st.

# Letters to the Editor

The Editor does not necessarily endorse opinions expressed by his correspondents

## Symmetry in class B

I have carefully read Mr. King's letter in the July issue (p.330), and I am sorry to have to say that I think his argument has gone astray.

The signal voltage  $V_s$  shown in Fig. 2 of my September 1969 letter (on earthed circuit) is not the same as Mr. King's  $V_s$ . As I thought I had made clear,  $V_s$  in my Fig. 2 is intended to represent the e.m.f. of the floating signal-voltage source, of internal resistance  $R_1^*$ , connected between points P and Q in my Fig. 1. A further point is that though Mr. King describes his Fig. 1 circuit as a simplified version of my circuit, it omits the vital and fundamental detail of a connection via a large capacitor from point B to a tapping on the top resistor shown in his diagram.

Mr. King feels that I have lost sight of the wood for the trees, and suggests also that it is impossible to produce shunt

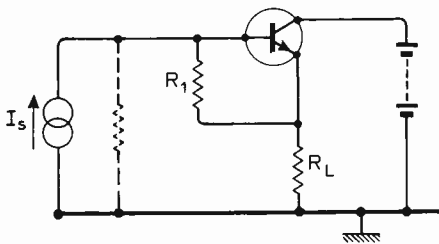

Fig. A.

feedback with one resistor earthed at one end. Consider, however, the accompanying Fig. A, ignoring for the moment the resistor shown in broken line. This circuit looks like an emitter follower, at first sight, but can hardly be properly regarded as such, since there is no negative feedback. The current source,  $I_s$ , feeding its current into  $R_1$ , produces a floating voltage source, of internal resistance  $R_1$ , connected directly between base and emitter, and the circuit functions as a simple common-emitter amplifier. Now consider the effect of connecting the broken-line resistor across the current source. As the value of the resistor is lowered, conditions tend more and more towards those of an ideal voltage-driven emitter follower, and feedback is thus increasingly introduced.

The same circuit as in Fig. A, redrawn with the transistor emitter earthed, is

\*  $R_1$  in Fig. 1, that is, not Fig. 2.

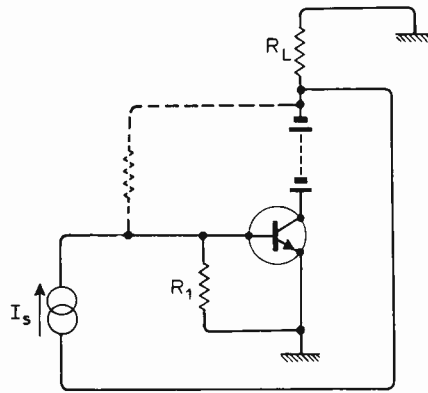

Fig. B.

shown in Fig. B, and it is now seen that the broken-line resistor can, indeed, be very properly regarded as a shunt feedback resistor.

Though circuit B is exactly equivalent to A, the circuits remain nearly enough equivalent, for many purposes, if the lower end of the current source, in circuit B, is earthed rather than taken to  $R_L$  as shown.  $I_s$  is so small, at least in the present context of audio output stages using transistor pairs, that it makes very little difference whether  $I_s$  itself is added to the much larger load current in  $R_L$  or not.

While attention has thus been focused on my letter of last September, I would like to take the opportunity to correct a genuine mistake, pointed out to me by Mr. I. J. Kampel, of Bournemouth. In the caption to my Fig. 5(b), curve 3 is said to apply to "Mr. Shaw's scheme". Unfortunately I had not noticed that, with the switch S in my Fig. 2 closed, putting a power diode in series with  $R_3$  does not exactly convert the circuit to Mr. Shaw's arrangement. To get the latter, one should add a 100-ohm resistor (using my value) between the lower driver emitter and the junction of  $R_2$  and  $R_3$  (i.e. earth), the lower end of  $R_1$  also going to this latter point. With these matters attended to, the input current characteristic becomes more like curve 2, and is thus a good match to the curve for the upper, Darlington, pair. I must apologize to Mr. Shaw for any implication that his circuit has significantly inferior

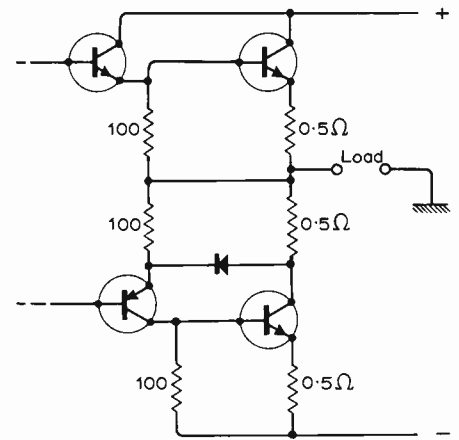

Fig. C.

linearity to that given by my low-power-diode scheme.

The connection of the 100-ohm resistors to the junction of the 0.5-ohm resistors, as Mr. Shaw does, is preferable, from the point of view of avoiding thermal runaway, to connecting them to the other ends of the 0.5-ohm resistors, as in my circuit—though this consideration is of much reduced importance now that silicon power transistors have largely replaced germanium ones. Improved thermal stability can, however, also be obtained with the low-power-diode-type of circuit, by arranging it as in Fig. C. Note that, in either type of circuit, to preserve the utmost symmetry of behaviour, a third 0.5-ohm resistor should be included at the bottom, as shown. Whether this small improvement is really worthwhile in practice, is, however, rather doubtful.

P. J. BAXANDALL,  
Malvern,  
Worcs.

## Sonex '70 report criticized

It is always rather saddening to read opinionated drivel in a much-respected technical journal. Even more so, when it is factually inaccurate.

The author\* of the smugly anonymous "report" on Sonex '70 in your June issue was either jaundiced by an outside chip on his shoulder or otherwise coerced by commercial influences. I know of no other account of a technical exhibition which is opened with a discussion of the journey to the venue.

There follows a blistering attack on a handful of exhibitors and the remarks concerning the KEF demonstration imply a certain disregard of musical values. Now, it may interest you to know that the formula for that demonstration was evolved from a careful study of public preferences, following comments in the correspondence columns of a popular hi-fi magazine. As a result, KEF abandoned their previous demonstration format which used only two types of loudspeaker, and played a predominantly classical programme. Instead a very varied selection of shorter items was switched through all available speaker

\*It is a widely accepted convention in journalism that unsigned material is a statement by the journal. Ed.

systems. The preparation of this demonstration took about 200 man-hours, and if your reviewer did not like the result, we are naturally sorry and he is, of course, entitled to say so. But he is not entitled to assume or imply thoughtlessness on our part.

The statements regarding acoustic isolation are seriously in error, because the transmission loss between adjacent rooms was more than 20 dB better than the hardboard cubicles used in Olympia in 1969. When annoyance was caused, it was usually attributable to abnormally loud playback and open casement windows which reflected the sound along the outside of the building. The ship-builder surely cannot be blamed for a sinking if the skipper insists on sailing with the seacocks open.

In the closing stages of his article, your reviewer calls for standardized reproducing equipment. This is a wonderfully Utopian concept in which we look forward to a British standard amplifier prescribed by a newly formed Ministry of Home Entertainment. In practical terms, however, I very much doubt that such a development is either probable or even desirable.

RAYMOND E. COOKE,  
Managing Director,  
KEF Electronics Ltd.

### Class AB amplifier

Mr. Linsley Hood is quite correct when he states that the operation of transistor output stages in class AB can cause increased distortion, because of the change in the slope of the transfer characteristic around the crossover point. However, I fear that he is wrong in supposing that a low source impedance overcomes the problem.

Fig. 1 shows a test circuit which I constructed to measure the transfer characteristic of the output stage under various bias conditions and the results are shown in Fig. 2 for 200mA, 20mA and 0mA. Note the prominent change in slope at 200mA bias. In the test circuit the transistors are operated in the common emitter mode to enable the changes in the slope of the transfer characteristic to be seen more easily, but this does not alter the validity of the results since the effect of putting the load into the emitter circuit is only to provide local negative feedback. Under the same conditions a push-pull emitter follower using an output stage with the transfer characteristic of Fig. 2(b) will produce less distortion than a similar output stage with the transfer characteristic of Fig. 2(c).

To check this I constructed Mr. Linsley Hood's amplifier and measured the distortion at 200mA and 20mA bias current with a Marconi TF2330 wave analyser and TF2100/1M1 low-distortion oscillator. The results are shown in Fig. 3 and show clearly the improvement in distortion at intermediate output levels produced by the lower bias current. However, in spite of the excellent results obtained I would not advise constructors of this amplifier to use

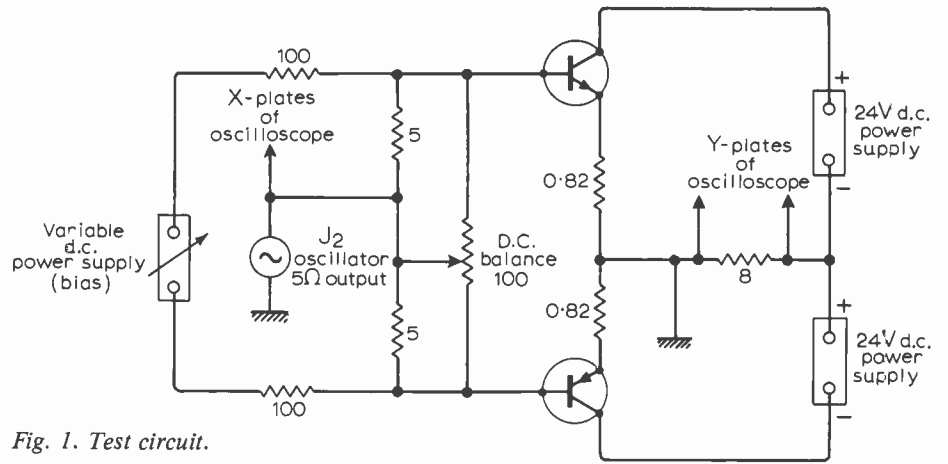

Fig. 1. Test circuit.

a bias current as low as 20mA as it tends to be rather unstable. A bias of 50mA would be about the optimum and at this level there would still be a "hump" in the distortion curve but it would be smaller than at 200mA bias and removed to a lower power level. I would also consider the use of a temperature compensating diode or transistor in the bias network strongly advisable, to minimize thermal variations.

Mr. Linsley Hood is also incorrect when he states that the emitter follower driver  $Tr_3$  presents the output transistors with a low source impedance. This would be true if it were not for the bootstrap capacitor which raises the effective value of the  $6.8k\Omega$  load resistor in  $Tr_2$  collector to around  $50k\Omega$ . Thus the source impedance seen by the output transistors is about  $1k\Omega$ , i.e. about twice their input impedance with an  $8\Omega$  emitter load.

A further point concerns the current gain of the output transistors. The specified gain spread for the MJ481/MJ491 devices used is 30-200 at 1A. As only 40mA is available from the driver stage the peak collector current with minimum gain devices is only 1.2A. This corresponds to an output power of about 8 watts into  $15\Omega$  and 5 watts into  $8\Omega$ . To achieve the output power claimed by the author the output transistors need to have a minimum current gain of around 80 at 1A. Perhaps the author could suggest alternative component values for those unfortunate enough to get low-gain transistors.

One last point. The author obviously attaches great importance to "square-wave transfer distortion" but he has not yet told us how he defines it. It is well known that any network, whether it be active or passive, that does not have a linear phase/frequency characteristic will produce transient distortion of a square wave. Does the author consider that, for example,

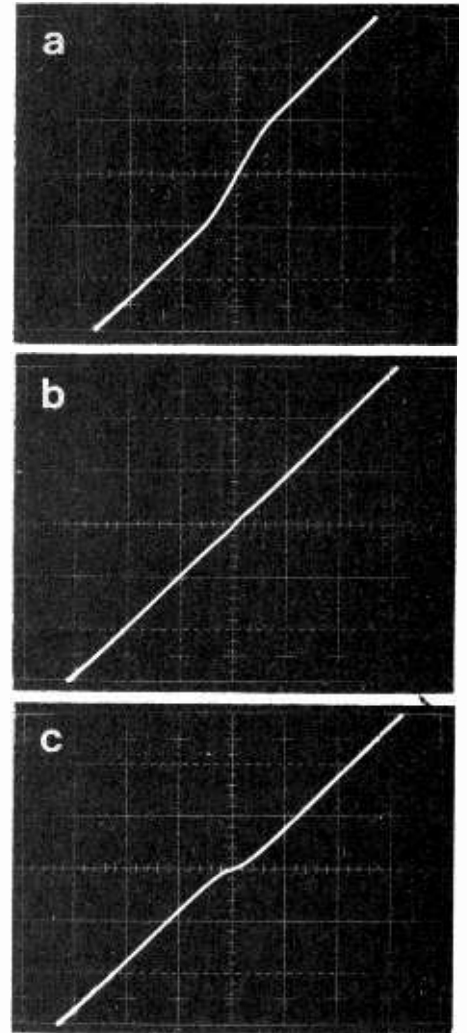

Fig. 2. Transfer characteristics at 200mA bias (a), 20mA (b), and 0mA (c). Vertical scale 500mA/division, horizontal scale 500 mV/division.

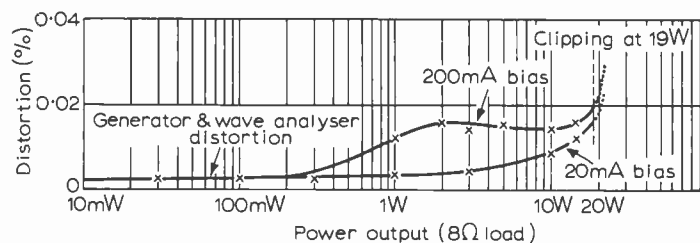

Fig. 3. Distortion Versus output power for bias currents of 200 and 20mA (load  $8\Omega$ , frequency 1kHz).

an *L-C* filter with a sharp cut-off at 50kHz would produce audible distortion? The ringing produced by such a filter would be very similar to that produced by an audio amplifier with a load of 15Ω and 2μF.  
D. S. GIBBS,  
Bury,  
Lancs.

*The author replies:*

Mr. Gibbs' letter raises a number of interesting points, with some of which I concur. However, I regret that he has misunderstood the argument in some cases.

To take his points separately.

1. *Optimum quiescent current:* The fact that there is an optimum value of quiescent current in a class B output stage for minimum harmonic distortion is well known and is not in dispute. This optimum current depends, among other things, on the current gain of the output transistors (or the product of the current gains if a Darlington pair or a similar output stage configuration is used) and, to a first approximation, the higher the effective current gain of the individual halves of the output stage the lower the optimum value of quiescent current. From the figures Mr. Gibbs quotes it would seem that the transistors he chose for this experiment had a high value of current gain.

However, this is not the point. I believe that the bulk of normal listening is done with output power levels which are of the order of only 50-250mW, only the very occasional transients demanding power levels in the 1-2 watt region. I also believe that it is advantageous for the amplifier to operate in true class A bias conditions for normal listening power levels, in that this avoids most of the ill-effects which can arise in class B, for example due to mismatched output transistor characteristics. These ill-effects produce the bulk of the high order harmonic and intermodulation distortions which appear to be objectionable to the ear.

Therefore, the question is simply which output stage configuration will operate best overall, with a forward bias of say, 200mA (this being chosen to allow class A operation up to 600mW), 1.2 watts with 8-15 ohm loads. The simple complementary emitter follower combination appears to be the best one for this purpose.

The measurement of very low order harmonic distortion levels is difficult, and is influenced by such things as h.t. supply impedances, lead connections, etc. and I am grateful therefore to find that Mr. Gibbs' measurements confirm my own findings that such a design, with such an output stage and forward bias does not give rise to harmonic distortion levels in excess of 0.02%. My own subsequent measurements with a harmonic analyser show that the distortion produced in the 'hump' region is mainly 3rd harmonic, whereas the higher magnitude of distortion produced by a more conventional complementary Darlington pair biased to 200mA, in a similar circuit, also contains more of these audibly objectionable higher order harmonics (see my Fig. A). Whether one has 0.015% or 0.005% t.h.d. is probably only of academic interest to the user.

2. *Base-emitter impedance:* For good high-frequency and transient performance it is desirable, I believe, that the impedance between base and emitter of the output transistors should be low. In the case of the class AB amplifier circuit, this condition is met by the 100Ω potentiometer, 400μF combination connected between the bases of the two output stage transistors, since when one of these is cut-off the other is conducting and provides the necessary base-to-emitter return path. The use of a relatively high driver impedance is actually advantageous in minimizing harmonic distortion due to the transistor base impedance non-linearity.

3. *Output power:* The question of the range of current gains to be found with the MJ 481-491 series transistors has been raised before in different contexts in these columns. My own experience with quite a large number of these is that the lowest current gain encountered, at 1A, is of the order of 75, and most, in fact, lie in the 100-150 bracket. However, this is not really an important limitation under dynamic conditions, because the effect of the bootstrap connection to the emitter load of  $Tr_3$  allows adequate drive current even with low-gain transistors.

4. *Audible effects of transient overshoots on reactive loads:* My experimental findings are that there is an occasional audible difference between an amplifier whose

stability under reactive load conditions is such that no overshoots are produced with a transient input and one which 'rings'. I do not think that this has anything to do with the nature of the h.f. response curve although it is evident that a 'ring' can be produced by a steep-cut low-pass filter. In the case of an audio amplifier driving a loudspeaker load, my own hypothesis is that some loudspeaker systems, under some dynamic conditions, can provide a negative reactive impedance, and this, however transitory, can exaggerate incipient reactive load instabilities present in the amplifier, and introduce spurious (and audible) waveform distortions.

I will take this opportunity of adding a personal note. In the original draft of my article, I walked into a philosophical booby-trap on the output power calculations, through overlooking the fact that current can flow both ways through the load. On subsequent consideration I became aware of this error, and the calculations shown in the Appendix 1 are correct. That part of the article relating to this—the last half of the third paragraph on page 322—is however, in error. The values 1.2W and 640 mW should be substituted for the 300 and 160 mW figures shown and the remaining 35 words of that paragraph deleted. I apologize to readers for this contradiction appearing in the text.

J. LINSLEY HOOD.

## Aerial noise

I wish to disagree with a statement made by your contributor P. G. Baker in the article "Aperiodic Loop Aerial" appearing in your May issue. He states, "The aerial output noise comes primarily from atmospheric and galactic sources hence the thermal noise introduced by the aerial radiation resistance is insignificant by comparison, provided the resistance is assumed to be at ambient temperature."

I suggest this conception is entirely erroneous. The noise temperature which can be allotted to a radiation resistance is that of the media to which it is coupled, the atmosphere and galaxy at the frequencies under discussion. Radiation resistance is not a physical resistance but a hypothetical one, generating no ohmic noise, but having a noise temperature due to its surrounding environment, which is usually considerably above earth ambient.

The only noise an aerial system can generate of itself, is that attributable to ohmic and dielectric losses in the aerial and feeder. As this noise contribution is of a considerably lower order than that resulting from external sources in the range up to approximately 30MHz, it can usually be ignored for design purposes. Furthermore as external noise is of a higher order than receiver noise at these frequencies it will remain the limiting factor in signal resolution, even for aerials with relatively inefficient space coupling.  
H. F. LEWIS,  
Ealing,  
London W.5.

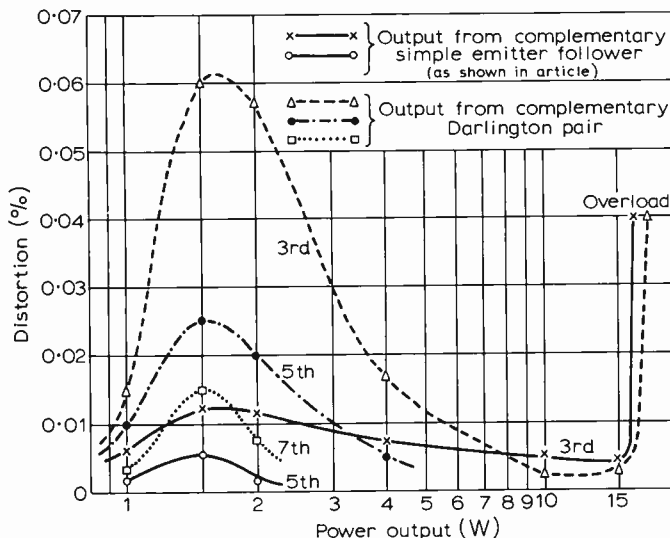
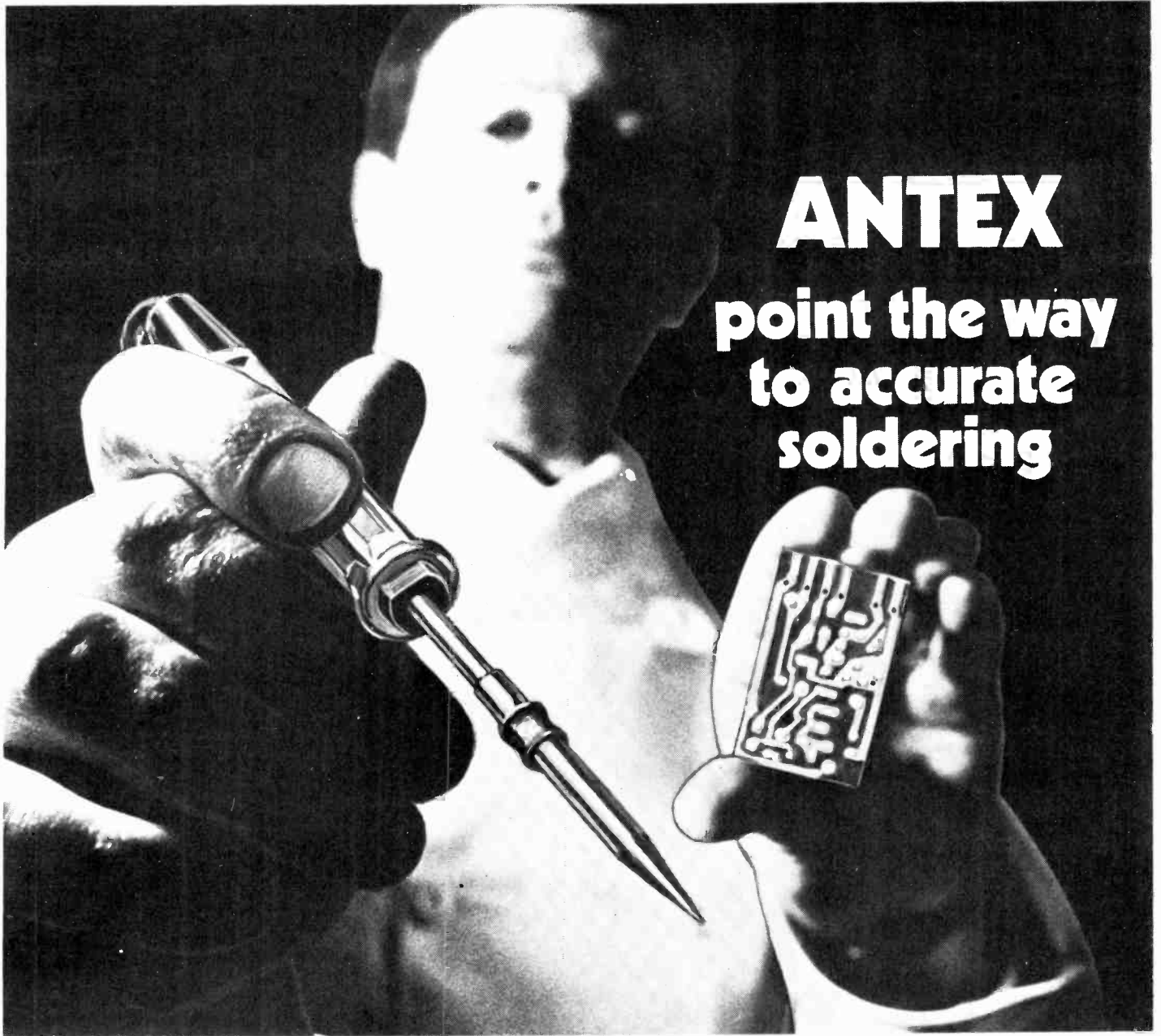
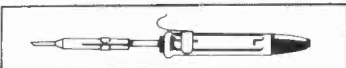

Fig. A. Measurements of Class AB amplifier with 200mA quiescent current and 15 ohm load. Second harmonic distortion below 0.01% was similar in both circuits.



# ANTEX

## point the way to accurate soldering



G18 watts. Fitted 3/32" bit for miniature work on production lines. Interchangeable spare bits, 1/8", 3/16" and 1/4" available. For 240, 220 or 110 volts. 36/-



E20 watts. Fitted with 1/4" bit. Interchangeable spare bits 3/32", 3/16" and 1/4" available. For 240, 220, 110 volts. From 36/-



ES25 watts. Fitted with 1/8" bit. Interchangeable bits 3/32", 3/16" and 1/4" available. Ideal for high speed production lines. For 240, 220, 110, 24 or 12 volts. From 36/-



F40 watts. Fitted 5/16" bit. Interchangeable bits 1/4", 3/16", 1/8", 3/32" available. Very high temperature iron. For 240, 220, 110, 24 or 20 volts. From 47/5. Spare bits and elements for all models and voltages immediately available from stock.

### Complete precision soldering kit

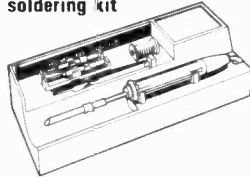

PLUS 36-page booklet on "How-to-Solder"—a mine of information for amateur and professional.

This kit—in a rigid plastic "tool-box" — contains

- Model CN 15 watts miniature iron, fitted 3/32" bit. Interchangeable spare bits 1/8", 3/16"
- Reel of resin-cored solder
- Felt cleaning pad
- Stand for soldering iron

From Electrical and Radio Shops or send cash to Antex. **55/-**



**Model CN 240/2**  
15 watts - 240 volts  
Fitted with nickel plated bit (3/32") and in handy transparent pack. From Electrical and Radio Shops or send cash to Antex. **36/-**



### PRECISION MINIATURE SOLDERING IRONS

Antex, Mayflower House, Plymouth, Devon.  
Telephone: Plymouth 67377/8.  
Telex: 45296. Giro No. 2581000.

- Please send me the Antex colour catalogue
- Please send me the following irons

Quantity	Model	Bit Size	Volts	Price
.....	.....	.....	.....	.....
.....	.....	.....	.....	.....

I enclose cheque/P.O./cash value

NAME .....

ADDRESS .....

..... WW8

**We  
snap,  
and we're  
quick  
to find  
fault...  
you'll  
love us!**

Electrosil's new Pick-a-Back connector, with the snap action, is the most advanced concept yet in D.I.P. testing. You can say goodbye to tedious test probes. Electrosil Pick-a-Backs are designed for D.I.L. packages mounted onto a P.C. board. Made specifically for testing and fault location, the connector will snap on to a D.I.L. package, obviating the need for test probes.

There is quick release action. You have no more costly "write-offs" due to accidental shorting between adjacent pins. Pick-a-back's integrally moulded contact comb prevents shorting and also serves as an attachment guide.

It can be used singly or in multiples to test complete I.C. boards before flow soldering.

● Gold plated beryllium copper contacts with wiping action for reliable contact. ● Four versions available to mate with all standard 14 pin and 16 pin D.I.P.s.

(Patent and Registered Designs applied for).

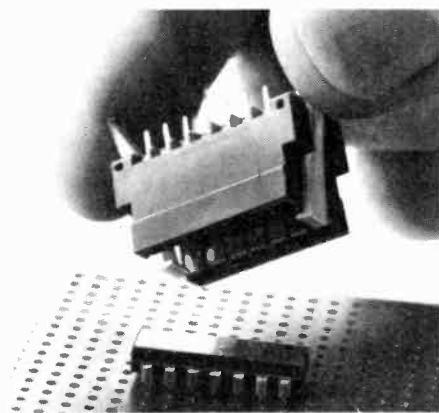

Write for full details.  
**ELECTROSIL LIMITED, P.O. Box 37,  
Pallion, Sunderland, Co. Durham.  
Tel: Sunderland 71481. Telex 53273.**



have the experience

[www.americanradiohistory.com](http://www.americanradiohistory.com)

ELC1

# 100MHz Frequency Divider

Extend the range of your digital frequency meter to 100MHz with this circuit which employs a tunnel diode and emitter-coupled logic

by D. R. Bowman, M.I.E.R.E.

A large number of digital frequency meters with a limited frequency range are in use in laboratories throughout the world and it is to extend the range of these instruments that the 100 MHz frequency divider described here has been developed.

The circuit consists of a wideband r.f. amplifier with gain extending from about 5 to 120 MHz followed by a very fast pulse squaring circuit which in turn feeds the logic divider stages as shown in Fig. 1.

At an early stage in the development it was decided to use integrated circuits wherever feasible. After a search of the literature it was decided to try the Motorola range of e.c.l.-2 (emitter coupled logic) for the frequency divider stages. To achieve the maximum toggle frequency from the JK flip flops the drive waveform must have rise and fall times each of equal to or less than 2 nsec. To achieve this performance it is necessary to use a tunnel diode in a waveform squaring circuit. The original intention was to divide the input frequency by ten (dotted Fig. 1) but this circuit was found to have a maximum frequency of operation of about 70 MHz. This frequency limiting is due to the low input impedance of the divide-by-five circuitry loading the first flip flop. The divide-by-ten instrument is somewhat cheaper than the 100 MHz divide-by-100 design and may be constructed as an alternative. The maximum frequency of operation is obtained, and the maximum impedance is presented by the JK flip flops when they are connected as binary dividers. The 100 MHz, divide-by-100, design overcomes its frequency limiting problem by operating the first two stages as divide-by-two, followed by two divide-by-five sections.

## Wideband amplifier

The tunnel diode pulse shaper requires a signal with an amplitude greater than 0.5 V to switch correctly. It was decided to design for a 10 mV sensitivity which dictates 40 dB of voltage gain for the amplifier. The use of voltage gain in this description can be justified as both the amplifier's input and output is terminated in 50  $\Omega$ . The idea of using emitter coupled pairs with ferrite wideband coupling transformers originated from some earlier work carried out by the author\*. The previous work demonstrated

the feasibility of u.h.f. amplifiers with very wide bandwidths. The requirement for the amplifier is a voltage gain of 40 dB with a bandwidth of 7 to 100 MHz.

Mullard manufacture a range of ferrite cores and it was decided to use type FX2249. These cores are small and exhibit very low losses up to at least 100 MHz. BFY90 transistors are used in the amplifier as they had been found to give repeatable results in this type of circuit. The minimum  $f_T$  value to be expected from BFY90 is in excess of 1,000 MHz. The emitter coupled circuit (Fig. 2) displays a very sharp limiting characteristic which gives the unit a very wide dynamic range.

The amplifier input is protected from damage that might be caused from large voltage swings by a silicon diode connected across the first emitter base junction. The

effect of this in conjunction with the base emitter diode of the first transistor is to limit the input signal to  $\pm 0.5$  V. To maintain interstage stability it is essential to isolate each stage of amplification by using Filtercons to decouple the individual supply leads. Erie Filtercons consist of a pi low-pass filter constructed by using two concentric ceramic capacitors separated by a ferrite bead threaded on the supply carrying wire. As the attenuation of these components is low at frequencies below 10 MHz it is necessary to bypass each one with a 0.1  $\mu$ F disc ceramic capacitor. It is found that the emitter follower stages of each transistor pair, due to the high  $f_T$ , can under certain drive conditions generate spurious parasitic oscillations. This difficulty has been eliminated by reducing the  $Q$  factor of the collector stray inductance circuit. Connect-

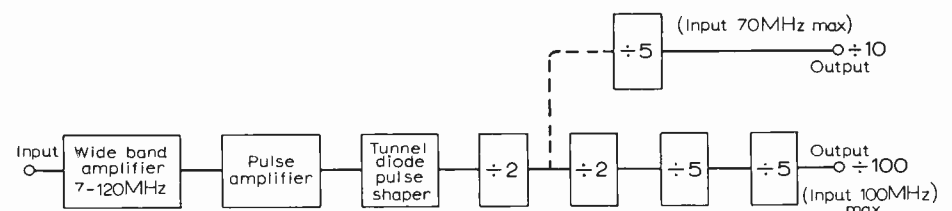
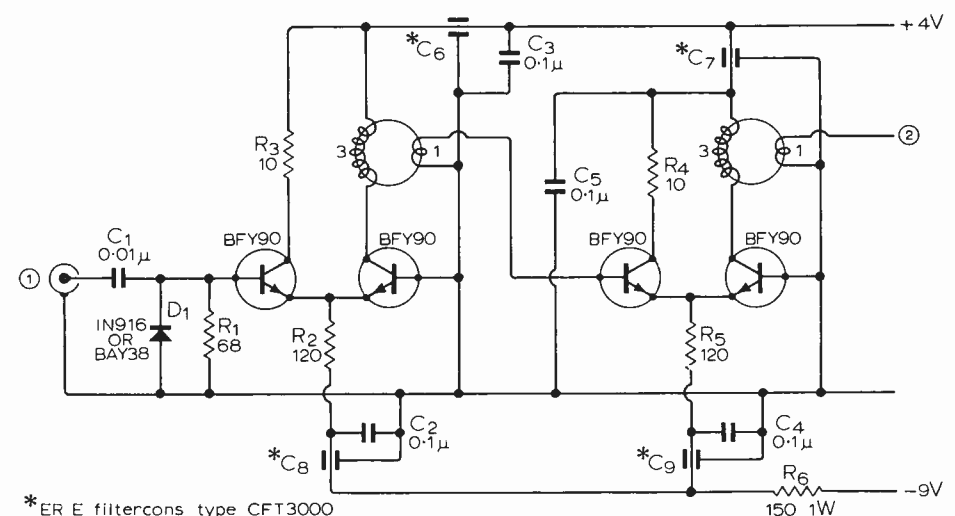

Fig. 1. Block diagram of the divider. The section shown dotted will divide by a factor of ten and may be used instead of the full divide-by-100 circuitry, however the maximum operating frequency will be reduced to 70 MHz.



\*ER E filtercons type CFT3000  
all other capacitors disc ceramic

Fig. 2. Wideband amplifier circuit. The transformers are wound with 24 s.w.g. enamelled wire, primary three turns, secondary one turn.

\*University College, London.

ing small 10 Ω resistors in series with the collector lead achieves this.

A second source of instability can occur in the stray inductance associated with the emitter circuit if the tail resistor has too high a resistance value.

The design of the ferrite transformers must take into account the performance at both ends of the frequency range. The l.f. performance depends upon the inductive reactance, stray effects only becoming important at the high frequency cut off of the transformer. These stray effects are mainly due to leakage inductance and lumped capacitance, both of which must be minimized to achieve the required h.f. performance. Leakage inductance is kept to a minimum by winding the primary and secondary of the transformer in very close proximity. The wire length per turn should also be as small as possible. The core used has two holes through which the primary and secondary should both be threaded. As each hole is common to both primary and secondary of the transformer, little increase in performance is gained by bifilar winding and, as this would be rather tricky, the author suggests that no attempt is made to twist the two windings together. The results achieved using a turns ratio of 3:1 are shown in Fig. 3. It is seen that the frequency response of the terminated transformer is substantially constant over the range of 0.5 to 60 MHz rising to a peak at 125 MHz. This peak tends to compensate for the amplifier's reducing gain with frequency rise.

The amplifier's performance using two of these wideband transformers to interspace the two emitter coupled amplifier stages is shown in Fig. 4. The gain is constant within ±3 dB over the range of 7 to 90 MHz. The graph shown in Fig. 5 indicates the instrument's performance and it can be seen that the signal required to drive the unit is never greater than 10 mV.

**Pulse shaper**

Following the amplifier is a common base connected stage (Fig. 6) whose purpose is to drive the tunnel diode pulse shaper

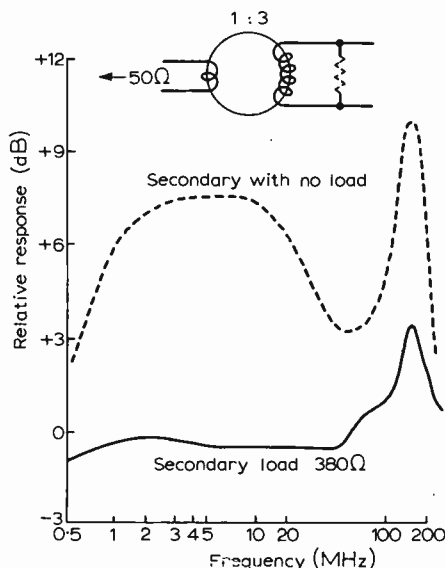

Fig. 3. Performance of the transformer wound on an FX2249 ferrite core.

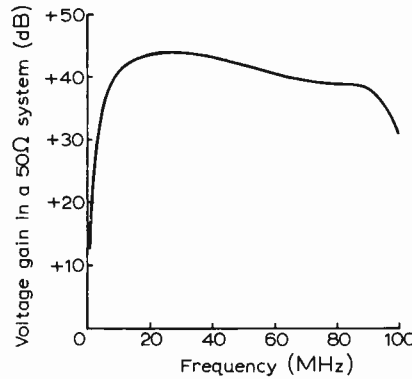

Fig. 4. Wideband amplifier gain plotted against frequency.

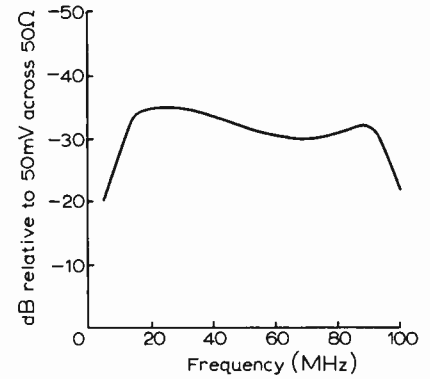

Fig. 5. Minimum input signal plotted against frequency.

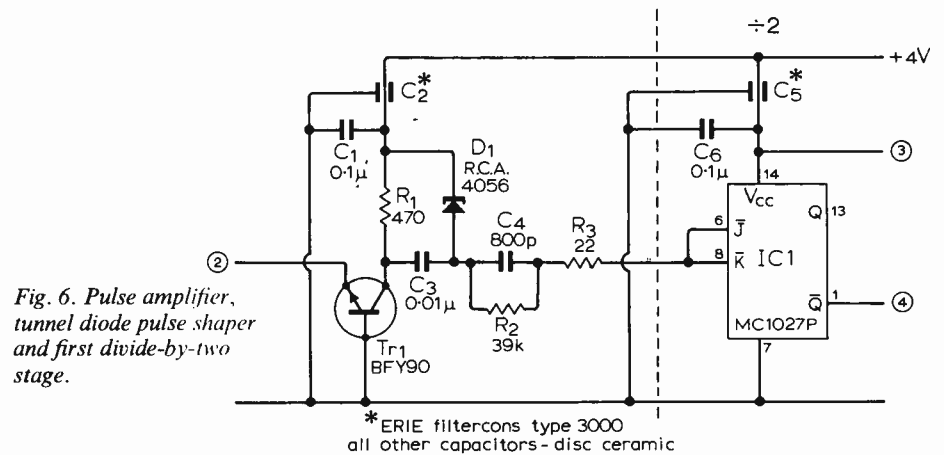

Fig. 6. Pulse amplifier, tunnel diode pulse shaper and first divide-by-two stage.

circuit. Tunnel diodes make very fast switches and can be expected to operate with rise times of anywhere from 100 to 2000 picoseconds. This time is mainly determined by the shunt capacitance of the diode together with the magnitude of the trigger pulse current. A pulse which raises the current through the tunnel diode to greater than the peak current will switch the device from its "on" to "off" state. If alternatively the pulse reduces the standing current to less than the valley current the diode will switch back to its "on" state. This process is clarified by studying the characteristic illustrated in Fig. 7. Diode switching time is defined as the period required for the voltage across the diode to rise from 10% to 90% of its maximum value.

This time  $t_r$  is derived as follows:

$$t_r = \frac{(V_{pp} - V_p)C}{(I_p - I_v)} \text{ sec}$$

where:

$C$  = the terminal valley-point capacitance.  
 $V_{pp}$  = the positive voltage greater than  $V_v$  at which the static current  $I_f$  is equal to the peak-point forward current  $I_p$ .

$V_p$  = peak-point voltage where  $dI_f/dV = 0$  for the first time.

$I_p$  = the peak-point current occurring with  $V_p$  above.

$I_v$  = valley-point current. The value of forward current  $I_f$  flowing at the second lowest positive voltage  $V$  at which  $dI_f/dV = 0$ .

Therefore the rise time for the diode used

(R.C.A. type 40566) is as follows:

$$t_r = \frac{(0.56 - 0.09) 15 \cdot 10^{-12}}{(5 - 0.6) \cdot 10^{-3}} \text{ sec}$$

$$= \frac{0.47 \cdot 15 \cdot 10^{-9}}{4.4} \approx 1.5 \cdot 10^{-9} \text{ sec}$$

$$t_r = 1.5 \text{ ns}$$

This time is well within the 2 ns required to drive the first logic stage.

**Divider stages**

Both the MC1013 and MC1027 integrated circuits employed are from the Motorola high speed e.c.l.-2 family. The MC1027 JK flip flop is guaranteed to toggle at frequencies up to 120 MHz although the author did experience some difficulty with this device above 100 MHz. The MC1013 toggled satisfactorily up to at least 85 MHz. These integrated circuits are intended for use with a negative 5.2 V supply and in the interest of maximum speed all unused input leads should be shorted to this line. A far simpler approach used by the author is to mount the dual-in-line devices on to copper laminated fibreglass board and by connecting the negative supply to earth all unused inputs can be simply soldered down to the earth plane. This does of course mean that  $V_{cc}$  pin 14 must be used as the positive 5.2 V input terminal. This results in the logic input levels being referred to the +5.2 V line, but this difficulty is easily overcome by referring the tunnel diode pulse squaring network to the positive rail. It has been found that the integrated circuits



will operate quite satisfactorily with supply voltages anywhere between 3 and 6 V. The maximum toggle speed of 105 MHz is achieved by the author's unit with a +3.9 V supply.

The MC1027 and MC1013 devices are basically binary dividers and a form of feedback has to be employed to divide by five. The circuit of the counter is shown in Fig. 8. The output is taken from Q on IC<sub>7</sub> giving a mark-space of 2 : 3 which will drive all digital frequency counters without any difficulty. A truth table for one divide-by-two and one divide-by-five stage is given in table one. As the fanout of these logic blocks is adequate to drive a 2-ft long coaxial cable leading to the associated counter the author

has not included a post divider amplifier. The output pulse has an amplitude of at least 0.3 V peak-to-peak.

**Performance**

The top three traces shown in Fig. 9 are oscilloscope pictures depicting the tunnel diode switching waveforms appearing at the input to the first logic divide-by-two stage. The first trace has a frequency of 100 MHz (10 nsec per cycle). The switching time is very short, of the order of 2 nsec. The second and third traces show similar waveforms of 55 and 10 MHz respectively. These waveforms were displayed using a Tektronix sampling oscilloscope with an effective

bandwidth of 1 GHz. The lower three traces show the output waveforms associated with the previous logic drive traces. These were displayed on a Tektronix 545B oscilloscope. The unequal mark-to-space ratio of the output signal is evident in these last three photographs, but has no detrimental effect on the following counter.

The frequency divider has been used to extend the operating frequency range to 100 MHz of both a Racal SA535 and a Venner TSA6636/2 digital counter. The minimum frequency at which the unit will reliably divide is about 4 MHz. Over the design range of 10 to 100 MHz the sensitivity is never worse than 10 mV across a 50 Ω input termination. As the total component

**Table 1**

state	IC 1	IC 2	IC 3	IC 4
0	0	0	0	0
1	1	1	0	0
2	0	1	0	0
3	1	0	1	0
4	0	0	1	0
5	1	1	1	0
6	0	1	1	0
7	1	0	0	1
8	0	0	0	1
9	1	0	0	0

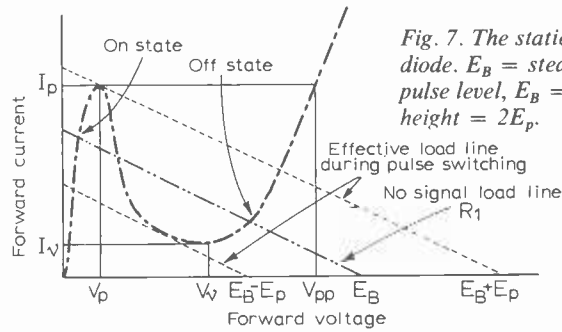

Fig. 7. The static forward characteristic of a tunnel diode.  $E_B$  = steady-state load line,  $E_B + E_p$  = positive pulse level,  $E_B$  = negative pulse level. Output pulse height =  $2E_p$ .

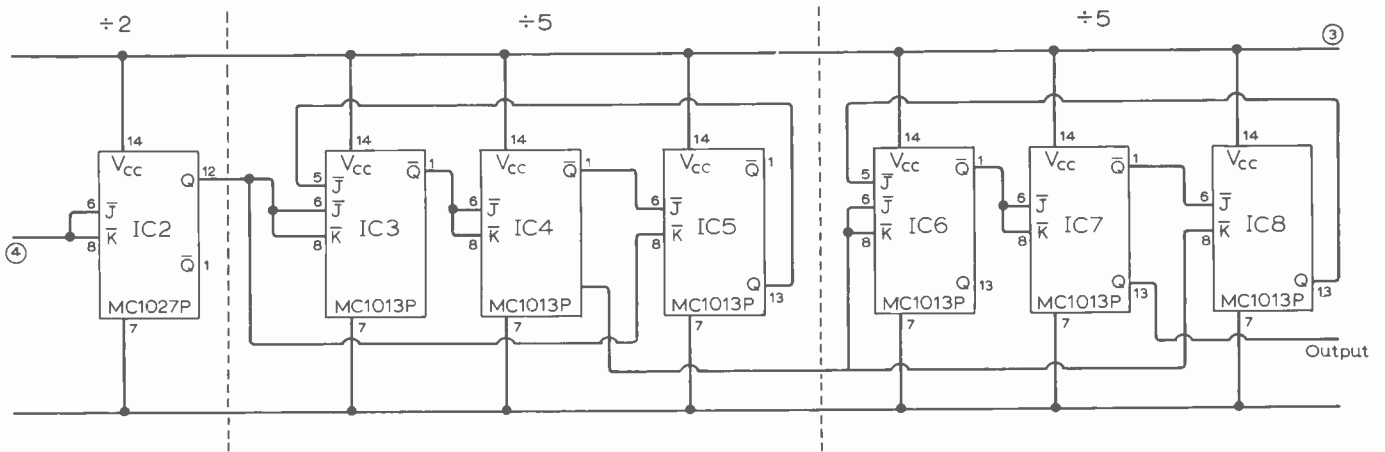
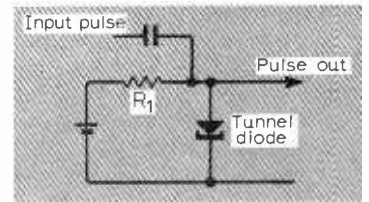

Fig. 8. The logic circuit diagram. The first divide-by-two stage is on the pulse shaper circuit.

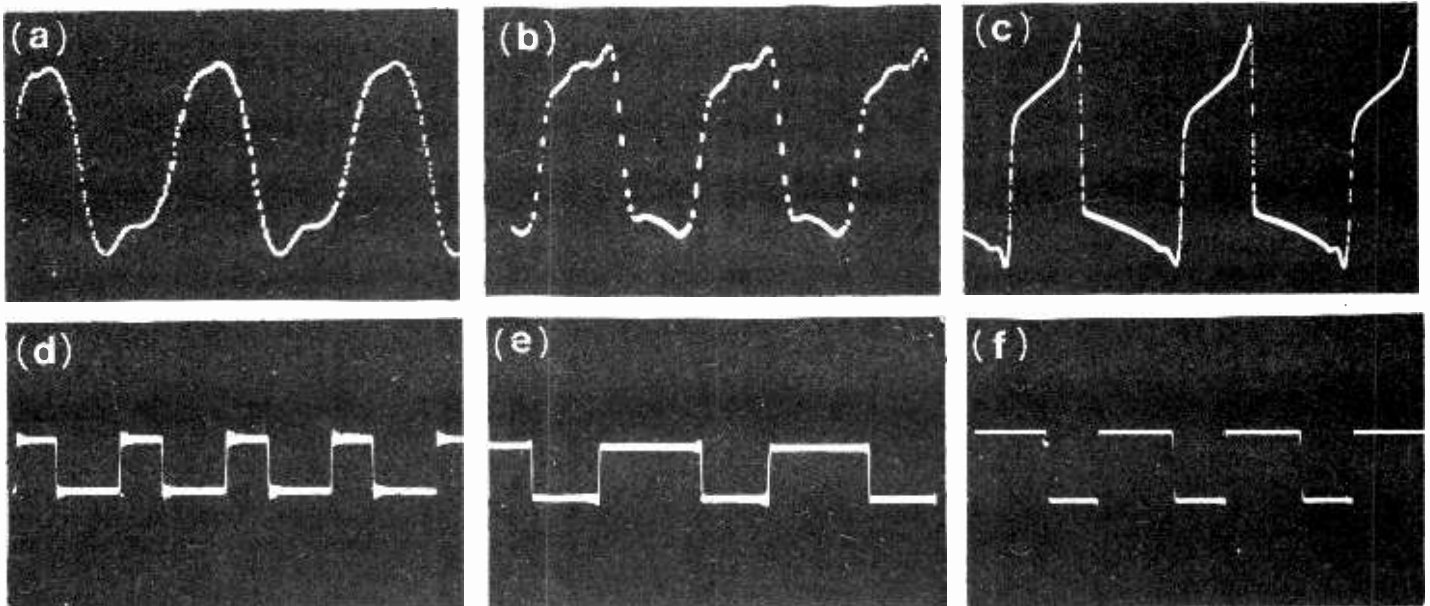

Fig. 9. Waveforms within the unit. The top waveforms are inputs to the divider and the lower traces are outputs.

cost of the instrument does not exceed £20 a considerable saving should be achieved as an equivalent performance commercial instrument is likely to cost upwards of £120.

**Power supply**

The power supply described here is a "universal" one based on a standard printed circuit board.\* A version is described which will power the frequency divider, but the circuit can be used to supply any voltage from 3 to 30 V at up to 100 or 200 mA. If an "outboard" power transistor is employed the output current is increased to 3 A.

The basic circuit (Fig. 10a) consists of a differential transistor pair with one input tied to the stabilized supply output voltage with the other referred to a zener regulated reference voltage. The current flowing in the collector circuit of the zener diode stabilized transistor  $Tr_2$  is used to drive the series connected stabilizing device  $Tr_1$ . On no load  $I_3$  flows almost entirely through  $Tr_3$ , but as the load current increases  $I_3$  is divided between  $Tr_2$  and  $Tr_3$ . As the load is further increased  $I_2$  becomes progressively larger until  $I_2 = I_3$ . At this point  $Tr_3$  refuses to supply any further current as its base voltage is tied by the zener diode  $Z$  and more current would mean an increase in the potential across  $R_2$ , thus further switching off  $Tr_2$ . At this point  $V_{out}$  begins to drop and the zener diode loses control further reducing the output voltage until the supply finally switches off. The fold-back characteristic is shown by both Figs 11 and 12. The circuit's voltage stabilizing action can be explained as follows. Assume a small reduction in load voltage which will, though

reduced in amplitude, be transferred to the base of  $Tr_3$ . This will produce a small reduction in the emitter current of  $Tr_3$ , and as  $R_2$  is common to both  $Tr_2$  and  $Tr_3$ , the emitter current of the former will increase. This increment in  $I_2$  will produce a current  $\beta$  times as great in  $I_1$ , thus restoring the load voltage.

**Performance**

The prototype provided the following performance figures which are by no means the best that can be achieved: 0 to 100 mA regulation >1%; ripple voltage <1 mV r.m.s.; output impedance <1  $\Omega$ . 0 to 1 A version, regulation >1%; ripple voltage <3 mV r.m.s.; output impedance <0.2  $\Omega$ . The circuit of the power supply for the frequency divider is shown in Fig. 13 and the layout is given in Fig. 14. It will be noticed that the common resistor  $R_2$  has been replaced by a potentiometer and a fixed resistor in series. Although not absolutely necessary it does allow the cut out current to be set accurately. The BD123 power transistor can be expected to exhibit a current gain of at least two even at 30 MHz. To avoid any suspicion of h.f. instability a limiting capacitor should be connected across the base to collector of  $Tr_4$ . It will be found that the voltage control potentiometers  $R_8$  and  $R_{15}$  have an extended range which can be used to obtain best overall divider performance.

**Design procedure for a power supply giving other voltages**

If the power supply is to be used for other than the frequency divider then decide on the output voltage required and calculate the stabilizer input voltage (from trans-

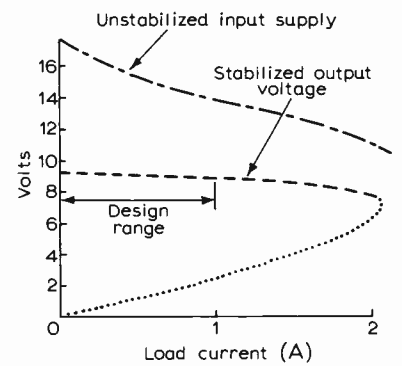

Fig. 12. Input output characteristics of 1 A output version.

former and full-wave rectifier) at no load and full load. Layout as in Fig. 15.

**Example one**

Full load current  $I_1 = 100$  mA; cut-out current = 400 mA.

Let  $V_{out} = 9$  V

Then choose  $Z \approx 2/3 V_{out} = 6$  V

Assume  $Tr_1 \beta = 50$  (BFY50)

and  $Tr_2, Tr_3 \beta = 100$  (2N3702)

Full load  $I_2 = I_1/Tr_1\beta$   
 $= (100 \times 10^{-3})/50 = 2.10 \cdot 10^{-3}$  A

Maximum  $Tr_2$  base current  
 $= I_2/Tr_2\beta$   
 $= (2 \times 10^{-3})/100 = 0.02 \cdot 10^{-3}$  A

The minimum zener current for good stabilization is about 1 mA:

Let zener current  $I_6 = 2$  mA

$R_1 = (V_{out} - V_z)/I_6$   
 $= (9 - 6)/2.10 \cdot 10^{-3} = 1.5$  k $\Omega$

Decide upon required cut out current:

$I_{max} = 400$  mA  
 $R_2 = Tr_1\beta(V_z - 0.5)/I_{max}$   
 $= 50(6 - 0.5)/0.4 = 690$   $\Omega$   
 $I_3 = (V_z - 0.5)/R_2$   
 $= (6 - 0.5)/690 = 8.10 \cdot 10^{-3}$  A  
 $I_4 = I_3/Tr_3\beta$   
 $= 8.10 \cdot 10^{-3}/100 = 80.10 \cdot 10^{-6}$  A

If  $Tr_3$  base voltage is to remain substantially constant then  $I_5$  must be at least twenty times  $I_4$ ; let  $I_5 = 2$  mA

Total divider

$RV_1 + R_3 = V_{out}/I_5$   
 $= 9/2.10 \cdot 10^{-3} = 4.5$  k $\Omega$

$RV_1 = 2.5$  k $\Omega$        $R_3 = 2.2$  k $\Omega$

Under certain conditions this circuit will not switch on. To correct this deficiency  $R_4$  is connected across  $Tr_1$ . The value of  $R_4$  is dependent upon the load at the instant that the supply is switched on. If the value chosen is such that with  $Tr_1$  switched off the load is great enough to keep  $V_{out}$  below about 1 V then the power supply will remain in a paralysed state. With  $V_{out}$  less than 1 V  $Tr_2$  and  $Tr_3$  will be cut off thereby starving  $Tr_1$  of base current and the only

\*Available from A. C. Mansell, 46 Headley Rd, Woodley, Reading, Berks. Price 10s 6d.

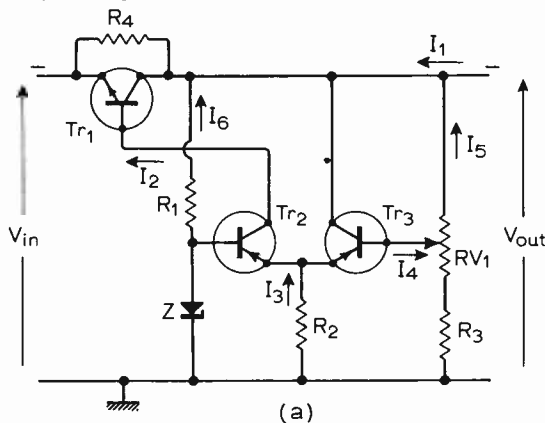

Fig. 10. (a) power supply basic circuit, (b) modification to increase current output.

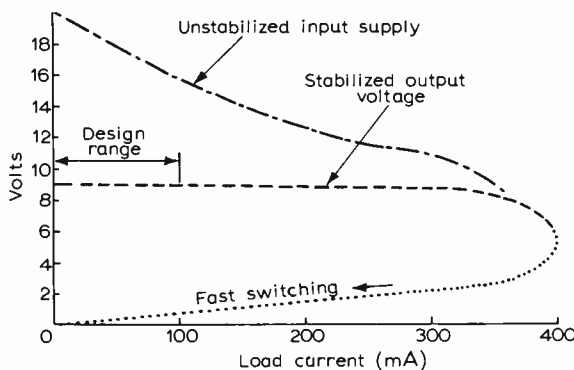

Fig. 11. Input and output characteristics of the power unit. 100 mA, 9 V version.

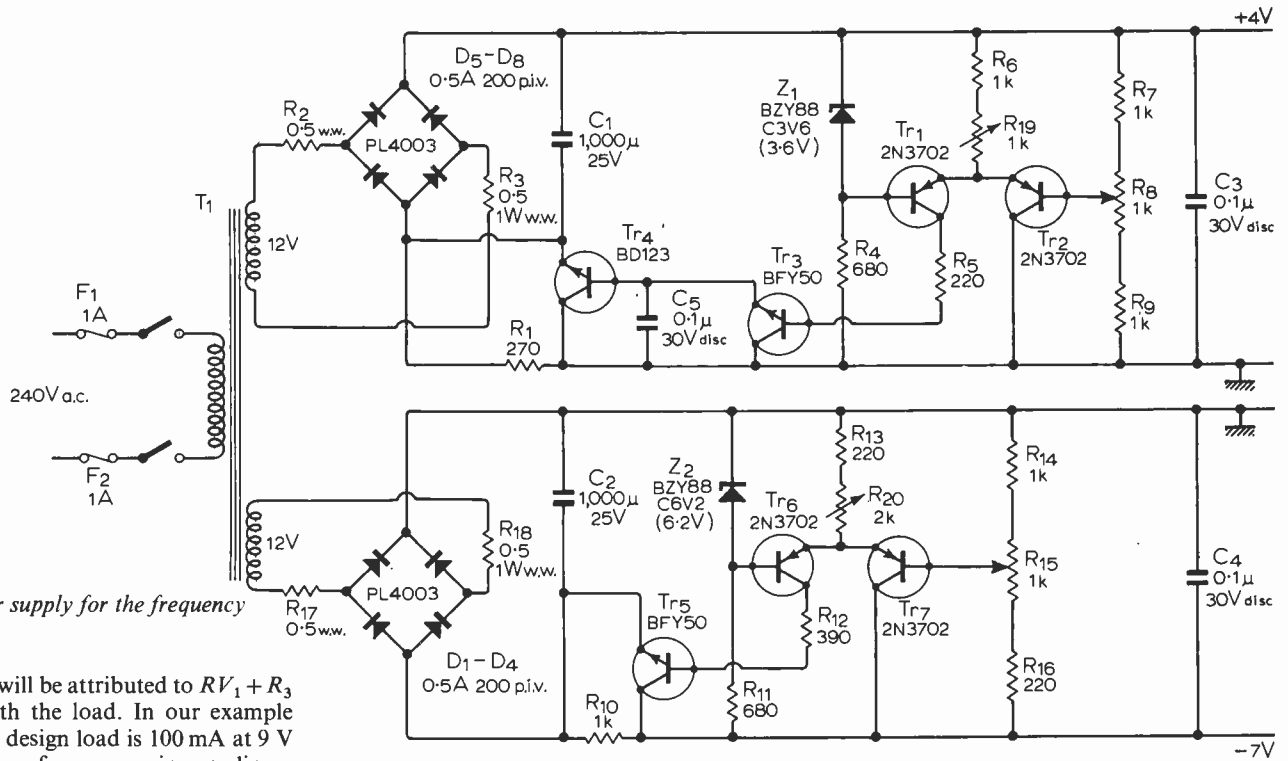

Fig. 13. Power supply for the frequency divider.

current drain will be attributed to  $RV_1 + R_3$  in parallel with the load. In our example the maximum design load is 100 mA at 9 V i.e. 90 Ω. Therefore assuming a linear related load at 1 V output:

$$\begin{aligned} \text{Load current} &= 1V(RV_1 + R_3) + (1V \cdot I_1) / V_{out} \\ &= 1/2 \cdot 10^{-3} + (1 \times 0.1) / 9 = 12 \cdot 10^{-3} \text{ A} \end{aligned}$$

Refer to Fig. 11. For a load current of 12 mA the input unstabilized potential is 19 V

$$\begin{aligned} R_4 &= (V_{in} - 1) / \text{Total load current} \\ &= (19 - 1) / 12 \cdot 10^{-3} = 1.5 \text{ k}\Omega \end{aligned}$$

**Example two**

Full load current  $I_1 = 1 \text{ A}$ . Cut-out current = 2 A.

$Tr_4$  transistor type BD123,  $\beta = 20$

$$\begin{aligned} R_2 &= [(V_z - 0.5)Tr_1\beta \times Tr_4\beta] / I_{max} \\ &= [(6 - 0.5)50 \times 20] / 2 = 2.75 \text{ k}\Omega \end{aligned}$$

There is no need to alter the component values derived in the first example with the exception of removing  $R_4$  and installing  $R_5$  as shown in Fig. 10(b)

Full load current = 1 A

At  $V_{out} = 1 \text{ V}$

$$\begin{aligned} \text{Load current} &= 1V / (RV_1 + R_3) + (1V \cdot I_1) / V_{out} \\ &= 1/2 \cdot 10^{-3} + (1 + 1) / 9 = 0.1115 \text{ A} \end{aligned}$$

Refer to Fig. 12. Unstabilized input voltage is 17 V at a load current of 0.1 A.

$$\begin{aligned} R_5 &= (17 - 1) / \text{Total load current} \\ &= 16 / 0.11 = 150 \Omega \end{aligned}$$

make  $R_5 = 129 \Omega$

Note:  $Tr_4$  must be adequately heat sinked.

**REFERENCE**

Bowman, D. R., "600 MHz intermediate frequency amplifiers", *Electronic Engineering*, August 1970.

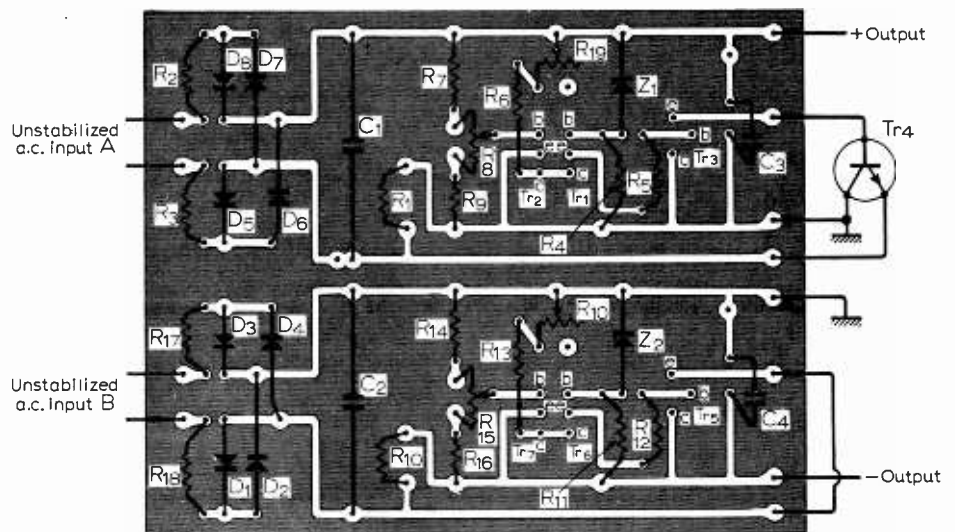

Fig. 14. Layout of power supply on standard board, frequency divider unit version.

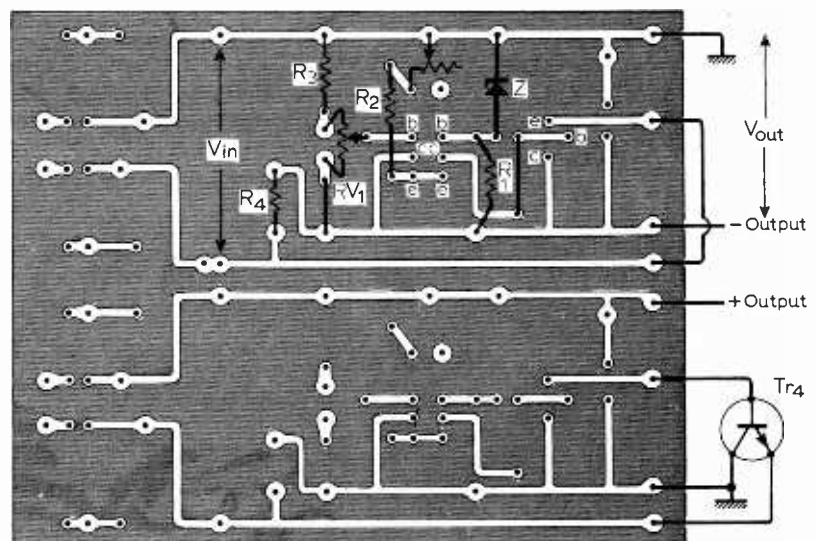

Fig. 15. Layout of power supply for other purposes.

# Transient Trinity

## Walkabout with Fourier, Laplace and Cauchy

by Thomas Roddam

One of the oddest features of the world of electronics engineers is the reluctance of many of them to do any mathematics. In large companies this does not show up very much, because the jobs are carved up into neat segments and the basic analysis is done by men who never even look at a soldering iron. In small companies it is a very different story, and one hears tales of some very rum goings-on indeed. The great advantage of the theoretical approach is that it is so much easier and quicker. The problem is that more and more of the literature is devoted to the reporting of new and highly sophisticated techniques. Now you need to run as fast as you can and you still will not stay where you are. And if you weren't anywhere in particular to begin with you do not know which way to run.

In this group of articles I have tried to look at some of the basic ideas and to follow where they led me. By asking what a capacitor and an inductor actually do I found why we use sine waves and why the damped sine wave is the real basic signal in our world. This led on to the idea of roots, the set of labels which characterize every circuit. There remains one topic which must be explored. In an article on transient response I took what may be called a fundamentalist approach. Now it seems appropriate to see how the formal treatment of transient behaviour has evolved.

Fourier analysis is the basis for something we do every day. We test circuits with sine waves and we assume that the results are meaningful when applied to practical signals. Practical signals are rarely long-sustained sine waves. The reasoning behind our behaviour is based on the Fourier series and on the principle of superposition. We start off by writing the series

$$\begin{aligned} & \frac{a_0}{2} + (a_1 \cos x + b_1 \sin x) \\ & + (a_2 \cos 2x + b_2 \sin 2x) + \dots \\ & (a_n \cos nx + b_n \sin nx) + \dots \end{aligned}$$

It is assumed that the series converges uniformly when  $0 \leq x \leq 2\pi$ . This amounts to saying that there are certain ground rules which must be obeyed, or the pure mathematicians will get you. What happens in a Cup Final, apart from a riot, if the ball bounces off a low-flying helicopter into the net? I haven't thought too much about this, but I do not think one can *construct*, with

real components, a non-convergent series signal. Strays will always save you. However, that's the rule, and if the function obeys it, it will converge uniformly for all values of  $x$ . It will also satisfy the equation:

$$f(x) = f(x + 2\pi).$$

From this it follows that

$$\begin{aligned} f(x + 2\pi) &= f(x + 4\pi) \\ f(x + 4\pi) &= f(x + 6\pi) \end{aligned}$$

and so on. It is, in fact, a periodic function with a period of  $2\pi$ . When we write  $x = \omega t$ , it is periodic in  $\omega t$ , and the period is  $t = 2\pi/\omega$ , or  $1/f$ .

In plain English, always dangerous in dealing with mathematical situations, a wave form which is periodic can be represented by a set of sine and cosine waves. The superposition principle says that if we have a linear system we can treat each of these separately and then add them up at the end. In a decent sound reproducing system you can take the signals from a number of instruments, apply them all to the input together, and you should still be able to tell the difference between a flute and a fiddle at the end. If the system is not linear each signal affects the progress of the others.

The mathematician shows us how to find the coefficients. We can write down  $f(x) = a_0/2 + (a_1 \cos x + b_1 \sin x)$  etc., and multiply both sides by, say,  $\cos nx$ . This gives a rather long expression, containing terms of the forms

$$\cos nx \sin mx, \cos nx \cos mx.$$

Now either  $m = n$  or  $m \neq n$ . If  $m \neq n$  we can show that

$$\int_0^{2\pi} \cos nx \sin mx \, dx = 0$$

$$\text{If } m = n, \int_0^{2\pi} \cos^2 nx \, dx = 1/\pi.$$

Applying this to the series we get, rather simply

$$\int_0^{2\pi} f(x) \cos nx \, dx = \pi a_n$$

and a similar term with  $\sin nx$  if we multiply through by  $\sin nx$ :

$$\int_0^{2\pi} f(x) \sin nx \, dx = \pi b_n.$$

Very often we can carry out the calcula-

tions using just a slide rule. One simple example is if we want to know how much third harmonic there is in a square wave. The function  $f(x)$  is 1 for  $0 - \pi$  and  $-1$  for  $\pi - 2\pi$ . The integral for the third harmonic is seen at once to be one-third of that for the fundamental.

What we said above was that we start with a series, and go on to call it  $f(x)$ . When we start with  $f(x)$  we can write down a Fourier series. The rule is that  $f(x)$  and  $df/dx$  must be, as they say, piecewise continuous. This does not mean it cannot have any jumps in either  $f(x)$  or  $df/dx$ . It really means it must not be all jumps. Anyone who has seen the news reports coming in by teleprinter knows the difference between the odd letter that went wrong and the whole paragraph of total confusion. At any jump it is assumed that as  $f(x)$  jumps from  $f_1$  to  $f_2$  it touches down to make

$$f(x_0) = (f_1 + f_2)/2.$$

The elegant form of Fourier is obtained by writing

$$\cos nx + j \sin nx = \exp(jnx).$$

Then

$$f(x) = \sum_{n=-\infty}^{\infty} C_n \exp(jnx)$$

$$\text{with } C_n = \frac{1}{2\pi} \int_0^{2\pi} f(x) \exp(-jnx) \, dx$$

Here  $n$  goes from  $-\infty$  through 0 to  $+\infty$ .

Suppose we have a non-periodic waveform of the kind shown by the heavy line in Fig. 1. We are, however, only interested in what happens during a limited time, evenly spaced round the mid-morning coffee-break at  $t = 0$ . We begin to observe the function at  $t = -\pi/\Omega$ , and stop at  $t = \pi/\Omega$ . With a bland smile we say it could just be repeating the bit we have observed, for all we care. It could, in fact, be the wave-form  $\delta(t)$ . I am not going to write down the mathematics, which contains double integrals and is the sort of thing which discourages the reader. The thing is that by manipulating the solution one can arrive at a pair of equations:

$$f(t) = \int_{-\infty}^{\infty} F(j\omega) \exp(j\omega t) \, d\omega$$

$$F(j\omega) = \frac{1}{2\pi} \int_{-\infty}^{\infty} f(t) \exp(-j\omega t) \, dt$$

This nicely balanced pair is called a pair of Fourier transforms, and it relates the whole time history of the waveform to an infinite range of frequency, both negative and positive frequencies, of course. We can get rid of the negative frequencies, which appear in order to fill in the phase angles, by writing

$$f_1(t) = \frac{1}{2}[f(t) + f(-t)]$$

$$f_2(t) = \frac{j}{2}[f(t) - f(-t)]$$

and then

$$F(j\omega) = \frac{1}{2\pi} \int_0^\infty f_1(t) \cos \omega t dt$$

$$- \frac{j}{2\pi} \int_0^\infty f_2(t) \sin \omega t dt.$$

There is a mate in which we find  $f_1$  and  $f_2$  with an integration of  $\omega$  from 0 to  $\infty$ .

This continuous pattern is the Fourier Integral. To use it we assume that for the system with which we are concerned we know the frequency response in the form of the ratio of detected current to applied voltage for sinusoidal inputs at all frequencies: the frequency response, in fact. We write

$$I(j\omega) = Y(j\omega) E(j\omega)$$

Now we take some applied signal  $f(t)$ . We can find  $E(j\omega)$  by means of the equation

$$E(j\omega) = \frac{1}{2\pi} \int_{-\infty}^\infty f(t) \exp(-j\omega t) dt.$$

Multiply by  $Y(j\omega)$  to get the solution  $I(j\omega)$ . Now write

$$I(t) = \int_{-\infty}^\infty I(j\omega) \exp(j\omega t) dt$$

and we know the time response to the input, expressed also as a time function.

It's a lot of work, it does not take account of initial conditions, and for a unit step there are convergence troubles. Heaviside did not worry about convergence, and although he usually got the right answer his contemporary mathematicians were so indignant about his informality that they refused to consider just why this was so. On the other hand he was not too fussy about the order in which he differentiated and integrated, which landed him in trouble with his initial conditions.

When we introduced the idea of complex frequency it became clear that the pure sine wave is really an oddity. Over the whole complex frequency plane there is just that one line on which there is neither damping nor growth. In a passive system there must be some loss: the frequencies must die away. Mathematical solutions are always easier if we can keep away from special situations:

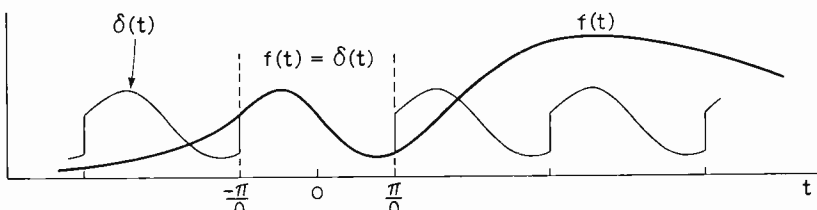

Fig. 1. Non-periodic waveform (heavy line) of which part under observation,  $-\pi/\Omega$  to  $\pi/\Omega$ , could belong to a periodic waveform.

reserve these for dealings on the Stock Exchange. The more elegant approach is the more realistic. First of all, we are in charge. Until we decide to switch on at  $t = 0$ , the excitation  $e(t) = 0$ . Secondly we write

$$s = \alpha + j\omega$$

We determine a function

$$E(s) = \int_0^\infty e(t) \exp(-st) dt.$$

This is almost the same as we had before, but now we have put  $\alpha + j\omega$  where he had  $j\omega$ , and we drop the integration from  $-\infty$  to 0 because  $e(t)$  is zero before  $t = 0$ . Also the  $1/2\pi$  is omitted. This is written as

$$E(s) = \mathcal{L}[e(t)]$$

and is called the Laplace transform of  $e(t)$ . The use of the complex frequency makes it possible to control the convergence of the integral. Obviously one can work the other way round, and in quite a few reference books you will find tables of Laplace transforms. I have picked out a few only:

$f(t)$	$\mathcal{L}[f(t)]$
$e^{-\alpha t}$	$\frac{1}{s + \alpha}$
$t e^{-\alpha t}$	$\frac{1}{(s + \alpha)^2}$
$\frac{1}{a-b} (e^{-bt} - e^{-at})$	$\frac{1}{(s+a)(s+b)}$
$\frac{1}{b} e^{-\alpha t} \sin bt$	$\frac{1}{(s+\alpha)^2 + b^2}$
$\sin \omega t$	$\frac{\omega}{s^2 + \omega^2}$
$\cos \omega t$	$\frac{s}{s^2 + \omega^2}$
Unit step ( $e^{-\alpha t}$ as $\alpha \rightarrow 0$ )	$\frac{1}{s}$

Without going into too much detail, suppose that we apply a signal  $e(t)$  to an LCR circuit. We can write, and initial charge is neglected,

$$E(s) = I(s) \left( sL + R + \frac{1}{sC} \right)$$

and  $E(s) = \mathcal{L}[e(t)]$

If  $e(t)$  is, say, 1 volt of d.c. switched in at  $t = 0$

$$E(s) = 1/s \quad \text{and so}$$

$$I(s) = \frac{1}{s} \frac{s}{s^2 + (R/L)s + 1/LC} \cdot \frac{1}{LC}$$

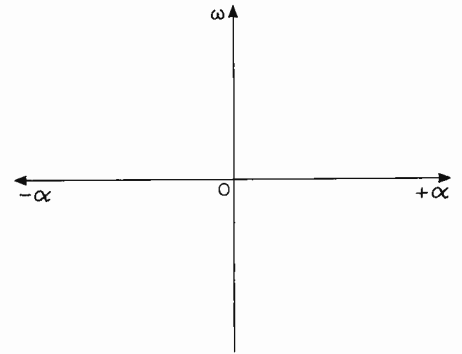

Fig. 2. Only on the  $\omega$  axis is there a pure sinusoid.

$$= \frac{1}{LC} \cdot \frac{1}{s^2 + (R/L)s + 1/LC}$$

If we extract the roots of

$$s^2 + (R/L)s + 1/LC = 0$$

we find that we have either

$$\frac{1}{(s+a)(s+b)} \quad \text{or} \quad \frac{1}{(s+a)^2 + b^2}$$

Now we transform back to get

$$i(t) = \text{either } \kappa(\exp(-bt) - \exp(-at))$$

$$\text{or } \kappa \exp(-at) \sin bt$$

Not much gained over a formal full analysis, you may think. But if there are a lot of roots it becomes rather easier this way. You find the roots and then break the whole thing up into separate functions which are transformable. This is simpler in practice because it is a routine and can be performed without thinking about decisions. There are many situations in which the advantages show up even more strongly. If you are studying the transient behaviour of filters you will have designed your filter in terms of its roots: you know the roots, not the frequency response, function-wise, that is. Of course your tables relate one to the other. But you are half-way towards this approach as soon as you decide between Tchebycheff and Butterworth. Active systems which are being handled by the root locus method are also easily studied to see how transient response changes as the roots are moved about.

Another important feature of the Laplace transform must be considered. We have seen that it enables us to dodge backwards and forwards between responses on the time axis and responses in the complex frequency plane. The mathematics is quite rigorous and has nothing to do with what we call the symbols. The reason for using rigorous mathematics is simply that it is easier, as you do not need to check up. Non-rigorous mathematics is like working out  $2 \times 2 = 3.99$  on the slide-rule: you need to keep thinking. We can give the symbols different names, provided the basic equations are suitable. One such pair of names can be found in the design of aerial systems. I am not going into any detail, but a uniformly illuminated slot transforms, just as an ideal low-pass filter does, into a  $(\sin x/x)$  response. Instead of the ringing of the time response we have the side-lobes of the space response. Just

as we can shape the frequency response to reduce ring, so we shape the illumination to reduce side-lobes. The advantages are tremendous. Measurements on a practical aerial must be carried out in the open on a wet and windy day. This is an observed fact, lacking theoretical justification. Mathematics is an indoor sport. It is also a set of general-purpose tools.

The search for flexibility goes one stage further. At first it looks as though it took one step back. The Laplace transformation equation can be written as

$$F(s) = \int_0^{\infty} f(t) \exp(-st) dt$$

and the rule is that  $f(t) = 0$  if  $t < 0$ . It will not matter, therefore, if we change the integration limits and take

$$F(s) = \int_{-\infty}^{\infty} f(t) \exp(-st) dt$$

Next we fix  $\alpha$  at  $\alpha_1$  into expression  $s = \alpha + j\omega$ , and we call this version of  $F$

$$F'(s) = \int_{-\infty}^{\infty} [f(t) \exp(-\alpha_1 t)] \exp(-j\omega t) dt$$

Compare this with the Fourier form

$$F(j\omega) = \frac{1}{2\pi} \int_{-\infty}^{\infty} f(t) \exp(-j\omega t) dt$$

The  $1/2\pi$  factor is simply the result of the pure mathematician's taking over. The inverse equation gives us

$$f(t) \exp(-\alpha_1 t) = \frac{1}{2\pi} \int_{-\infty}^{\infty} F'(j\omega) \exp(j\omega t) d\omega$$

We are allowed to move the  $\exp(-\alpha_1 t)$  term, because we are integrating with  $d\omega$ , and so

$$f(t) = \frac{1}{2\pi} \int_{-\infty}^{\infty} F'(j\omega) \exp(\alpha_1 + j\omega)t d\omega$$

Finally we change variables, putting back  $s = \alpha_1 + j\omega$ , and thus

$$ds = j d\omega \quad d\omega = (1/j) ds$$

We emerge with

$$f(t) = \frac{1}{2\pi j} \int_{\alpha_1 - j\infty}^{\alpha_1 + j\infty} F(s) \exp(st) ds$$

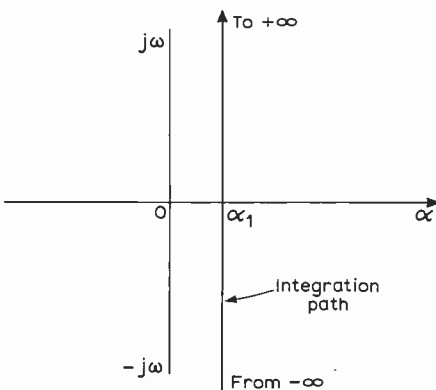

Fig. 3. The integration path for

$$f(t) = \frac{1}{2\pi j} \int_{\alpha_1 - j\infty}^{\alpha_1 + j\infty} F(s) \exp(st) ds$$

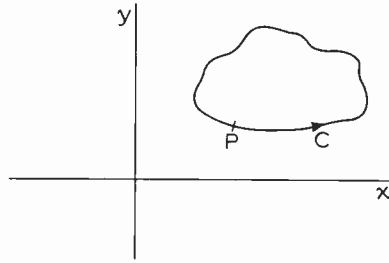

Fig. 4. At every point  $f(z) = f(x + jy)$  is analytic and single-valued. Then  $\oint f(z) dz = 0$  as you go round from P back to P.

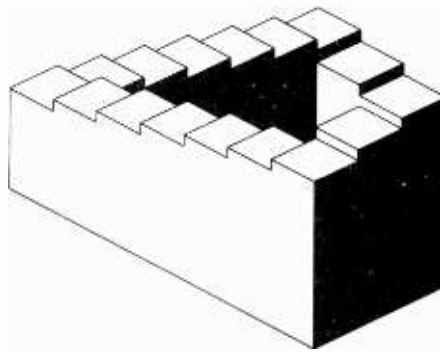

Fig. 5. Three-dimensional view of a function which, even if you smooth out the steps, is not analytic.

A good many readers will have regarded all this as a pretty complicated ritual. The object of going through the formality is to have this last expression to talk about, and to help to identify the fuller treatment you can find in the textbooks. In the expression above we integrate along the line shown in Fig. 3. For each value of  $s$  we work out  $F(s) \exp(st)$ , multiply by  $ds$  and sum. We choose  $\alpha_1$  to have a value which makes this a meaningful procedure. But are we any better off.

At this point we introduce one of those odd bits of mathematics which crop up all over. This is Cauchy's Theorem. This says that if you integrate round a contour, and if, in formal language, the function is analytic and single-valued everywhere inside and on the contour,

$$\oint_C f(z) dz = 0$$

Another bare diagram, Fig. 4. If you walk to work and back by a different route, without falling through an open man-hole, you finish up at the same height above sea-level. If you cycle it does not feel like this, and if you find a function like Fig. 5 you know it can't be analytic, even if steps are replaced by a ramp.

Cauchy's theorem, simple as it looks, is tremendously important in the theory of the complex variable—in our case the theory of complex frequencies. In consequence it must be proved with the utmost vigour and the proof is not too easy. We shall not bother with it here. What we want is this result that if you walk round a perimeter and there is nothing odd going on inside it you get back to where you started.

We were integrating along the line  $s = \alpha_1$ . If we close the ends by a semi-circle joining  $\omega_1$  to  $-\omega_1$  and integrate round the

whole loop, Cauchy's theorem tells us that if there are no poles inside the area the integral will be zero. We choose  $\alpha_1$  to make sure that this is true. This integration round the right-hand semi-circle is used for the response when  $t \leq 0$ . When the radius of the semi-circle is allowed to approach infinity, the integral along the semi-circle is also zero. This last statement is also true for integration along the semi-circle to the left, which we shall follow for  $t \geq 0$ . Now, however, the integral round the contour is no longer zero. Inside the contour there are poles, as we see in Fig. 7. Again the integral is zero round the semi-circle, when it is big enough, but the integral we really want is still left.

First of all, what can we do to make use of the properties of the contour integral? In Fig. 8 we see a pole,  $P$ , and a bigish circular contour round it. At  $AB$  we snip the contour and go off from  $B$  down to  $C$ , round the small circle to  $D$ , and then back to  $A$ . The pole is no longer inside this new contour and so the integral round it must be zero.  $BC$  and  $DA$  are very close together, and the integrals along these bits cancel out. The integral round the full big circle must therefore equal the integral round the small circle. We can do this with each pole, and we finish up by having small circles round the poles and zero for the rest of the contour integral.

We need to know a specific contour integral,

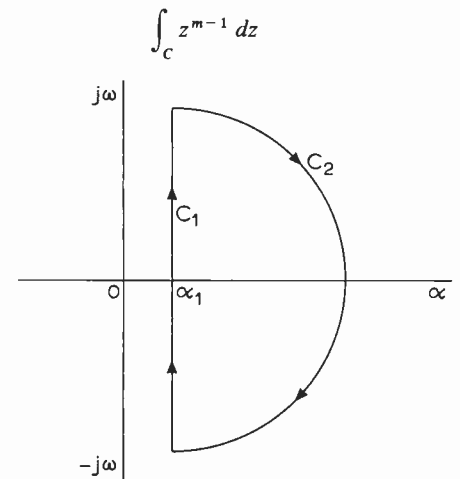

Fig. 6. Closing the path  $C_1$  with a semi-circle  $C_2$ .

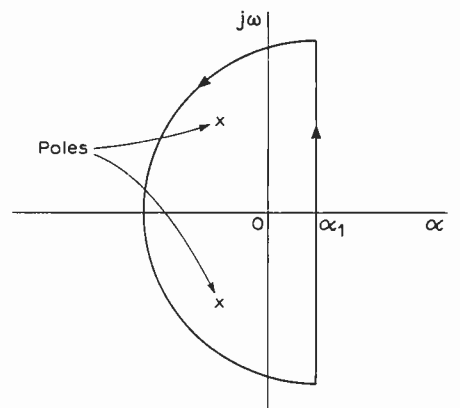

Fig. 7. Inside this contour are poles. Here be singularities.

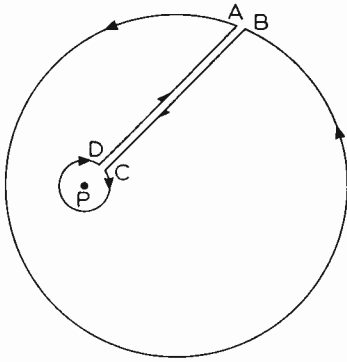

Fig. 8. Isolating a pole.

For  $m \neq 0$  this is zero, but if  $m = 0$ ,

$$\int_C \frac{dz}{z} = 2\pi j$$

and equally  $\int_C \frac{dz}{z-a} = 2\pi j$

We have embarked on what is called the calculus of residues. Suppose that we have a double pole at  $s = -a$ . This means that  $F(s)$  contains a term  $A/(s+a)^2$ . The function we are integrating is then  $\exp(st)/(s+a)^2$ , and we turn this into a series for values of  $s \approx a$ :

$$\frac{\exp(st)}{(s+a)^2} = \frac{a_{-2}(t)}{(s+a)^2} + \frac{a_{-1}(t)}{s+a} + a_0(t) + \text{terms in } (s+a)^n$$

The residue of the function at  $s = -a$  is  $a_{-1}(t)$ . This means that

$$\int_C A \exp(st)/(s+a)^2 \cdot ds = a_{-1}(t) \times 2\pi j.$$

To make life easier, we have an expression for the residue:

$$a_{-1}(t) = \frac{1}{n-1} \cdot \frac{d^{n-1}}{ds^{n-1}} \cdot \exp(st)$$

with  $s = -a$ .

For  $n = 2$   $a_{-1}(t) = t \exp(-at)$ .

$$f(t) = At \exp(-at)$$

The prospect of being hanged in a fortnight concentrates a man's mind wonderfully. This article is not a "how to fix your own operational calculus", but a "what's it all about". We begin with a network, a system, and we want to know how it behaves with real signals. The sine wave is a nice simple signal and so we try to build up our real signal with pure sine waves. On paper it is quite satisfactory. We call it Fourier analysis, and go gaily ahead until some awkward details appear. All the mathematics is based in eternity. We switched on yesterday and may not switch off tomorrow. If we get an infinite circuit, a pole on the  $j\omega$  axis, we can't be too sure what to do.

The mathematics is manipulated to make it more clearly defined, and to allow us to start up today, at  $t = 0$ . The frequencies we use are still on a line, but we can move it sideways to dodge trouble. We hardly know we have done this, because we can choose any line to the right of a critical one, and our choice disappears anyway in the table of Laplace transforms.

To widen our scope we consider what happens with every possible complex frequency, varying both  $\alpha$  and  $\omega$ . Cauchy's theorem leads us on to the conclusion that now we need only look at the poles themselves. The broadest possible input signal concentrates attention on the minimum number of points. All we need is a table of residues:

	$\exp st/s$	$\exp st/s^2$	$\exp st/(s+a)$	$\exp st/(s+a)^2$
Residue	1	$t$	$\exp(-at)$	$t \exp(-at)$

and we can work out the transient response. The hard work comes in getting to grips with the procedure, once and for all. It is true to say that solving problems this way is cheaper by the dozen.

Cauchy's theorem can be extended to deal with contours which go round a given point several times, and which include poles and zeros. This is the theoretical basis for

Nyquist's criterion in feedback amplifier theory, especially when dealing with conditional stability. This leads on to the rules for dealing with negative resistance circuits. Like sodium glutamate, Cauchy's theorem seems to be in everything nowadays.

Some engineers seem to consider mathematics as too detached from real work. It is quite profitable, even for the so-called

practical man, to get some idea of these theoretical techniques. Even if you are going to look at the responses on an oscilloscope, a knowledge of the underlying theory will save an awful lot of wasted effort by suggesting which way to vary components to get the cut-and-try answer. Who knows, in the end you may realize that it's easier to do the job properly from the beginning.

## Announcements

The Electrical Research Association's Circuit Design Department has initiated a return-of-post information service on techniques and components. A consultancy service is also available to clients who wish to discuss specific design and application problems. All enquiries should be addressed to Colin Ray, Design Information Engineer, E.R.A., Cleeve Road, Leatherhead, Surrey.

Centralab Ltd, of Co. Antrim, Northern Ireland, jointly owned by Joseph Lucas (Industries) Ltd and Globe Union Inc. of Milwaukee, U.S.A., has acquired the whole of the issued capital of **Stability Radio Components Ltd** and its subsidiary Stability Capacitors, of Basildon, Essex, at a price of approximately £727,000.

Pye have relinquished the **Ferranti trade mark** for radio and television products, and the right to use the name has been returned to Ferranti Ltd, of Manchester.

Tele-Nova Ltd, a company in the Shipton Automation Group, have signed a further agreement with Hasler Ltd, in Berne, Switzerland, for the sale in the U.K. and Eire of **Hasler** radio staff location systems.

The Telephone Manufacturing Co. Ltd has been appointed sole marketing agent in the U.K. for the range of switch and light units manufactured by the **Dialight Corporation**, of America.

An agreement has been signed between **Cossor Electronics Ltd**, of Harlow, Essex, and the **Raytheon Service Company**, of Massachusetts, to market the full range of **Cossor oscilloscopes** in the United States.

**Guest International Ltd** announce that Best and Raynor have ceased to act as their distributors. Full stocks are still being held by the company's other distributors: **GDS (Sales) Ltd.**, G.S.P.K. Ltd., and E.C.S. (Windsor) Ltd.

**Daystrom Ltd**, of Gloucester, manufacturers of the **Heathkit** range of products, have changed the name of the company to **Heath (Gloucester) Ltd**.

The former range of **Dansette** and **Perdio** record reproducers, radiograms and audio equipment is now being manufactured and marketed under the trade name of "Tonesta". **Electro-Impex**, of 4 Carlisle Avenue, London E.C.3, have been appointed by **Tonesta Ltd** as the sole selling agents for the U.K. and all overseas markets.

The **Electrotech Instrument Division** of **Coutant Electronics Ltd** has been acquired by **Instant Starter Engineering Co. Ltd**. The division has been formed into a new limited company, **Exel Electronics Ltd**, and becomes a wholly owned subsidiary of I.S.E.

**EMI** is to acquire all the shares of **Recording Designs Ltd**, of Camberley, Surrey, who specialize in magnetic tape data storage equipment for military and commercial use.

**Sprague factory in Scotland:** **Sprague Electric Company**, of Massachusetts, U.S.A., is to build a factory in Galashiels, initially to produce aluminium electrolytic capacitors. The company hopes to have the factory ready for occupancy by the autumn.

**Tektronix UK Ltd** has opened regional offices and a repair and recalibration centre at **Beaverton House**, 181A Mauldeth Road, Manchester 19. (Tel: 061-224 0446.)

The U.K. sales office of **EMI-Varian Ltd** has moved from **Walton-on-Thames** to the head office and factory site at **Blyth Road**, Hayes, Middx. (Tel: 01-573 5555.)

**Mullard Ltd** are to build a second factory for the production of television picture tubes at **Belmont**, near Durham.

# Time Delays

## 2. Delay tubes, storage devices, quartz thread, ceramic piezoelectric delay lines. . . .

by H. D. Harwood, B.Sc.

Last month's article on ways of producing time delays was devoted to all-pass electric circuits and ultrasonic methods. This month we start by looking at delay tubes.

### Acoustic delay tubes

This is the oldest form of time delay but it still finds occasional use because of the large values possible. The velocity of sound in a tube is similar to that in free air, namely 340 metres per second at 20°C. In narrow tubes a certain amount of dispersion takes place but attenuation at high frequencies usually limits the use of such a tube before dispersion becomes serious. The amplitude at a distance  $x$  is given by:

$$A = A_0 e^{-\alpha x}$$

where  $A_0$  is the amplitude at the beginning of the tube,

$$\alpha = \frac{\gamma'}{Rc} \frac{\omega}{2P}$$

$R$  is the radius of the tube in cm,

$c$  is the velocity of sound in cm/s,

$\omega = 2\pi f$ ,

$f$  = frequency in hertz

$P$  = density in gm/cm<sup>3</sup>

$\gamma' = 1 + 1.58(\gamma^{\frac{1}{2}} - \gamma^{-\frac{1}{2}})$ ,

and  $\gamma$  = the ratio of specific heats.

The maximum level is dictated by non-linearity effect in the air in the tube; distortion in a uniform tube is proportional to the length. The maximum length is determined by attenuation at high frequencies which leads to poor signal-to-noise ratio in the receiving microphone. As can be seen from the formula given above, attenuation is inversely proportional to the tube diameter but this cannot be increased beyond the point at which radial modes of resonance occur in the pipe with a consequent change in the characteristic impedance and production of serious echoes. The maximum diameter can be used is thus found in practice to be about 25 mm.

The termination of the tube is formed by means of graduated lengths of wool forming, in effect, a tapered absorber. Reflections are mainly troublesome in the middle frequency band as absorption at the bass is very good and air attenuation at high frequencies rapidly reduces any reflected wave. It is possible to improve the signal/

noise ratio at high frequencies by inserting the receiving microphone in the end of the tube and constructing the termination at right angles to it. At low and medium frequencies the sound turns the corner and is absorbed by the termination, whilst at high frequencies the inductance of the bend is too great and the sound is reflected from the microphone giving a rise in pressure of 6 dB. The reflected sound is heavily attenuated by the tube and does not cause any trouble from echoes.

In practice, the tube is usually coiled into a helix to conserve space. Delays of up to 100 ms are feasible over the audio band.

Applications are for artificial reverberation<sup>18</sup> and for delaying the onset of added reverberation to give the impression of a larger echo room.

### Storage devices

Storage devices differ from the preceding delay lines in that no inherent velocity of propagation is involved, the storage being a static effect. Various storage media have been proposed including homogeneous surfaces such as phosphors, magnetic tape, and electrostatic storage surfaces. However, the amount of energy associated with information stored by such means tends to be low with a result that the signal to noise ratio of the delayed signal is marginal by the best broadcasting standards. They share the advantage however that quite long delay times may be achieved, adequate for television field storage purposes. Discrete storage elements such as capacitors or inductors are able to store much larger quantities of energy and hence provide a better signal-to-noise ratio, but require individual switching and hence rather involved circuitry to handle the very large number of programme samples which would have to be stored for the delay period in any programme application. Furthermore, owing to the large number of picture elements it is not practicable to store a picture field and only a line store is convenient at present. A store of each type will now be described.

**Storage on cathode ray tube phosphors:** The storage of information on the phosphor of a cathode-ray tube dates back to the first computer stores. The total amount of information which could be stored by this

means, however, was small and the method is no longer used for this purpose.

It is however still useful for converting television pictures from one field rate to another. In this type of standards converter<sup>19</sup> the usual procedure is to display the picture on tube and photograph it using a television camera. Ideally in order to avoid a variation of picture brightness due to the difference in the number of fields per second the display tube should maintain constant brightness until one frame has been photographed and is replaced by the next. Unfortunately tubes of this type are unable to satisfy other requirements of standards conversion and phosphors with a finite decay time must be employed. A phosphor having an afterglow of about 9 ms gives the best compromise between the blurring of moving objects and gain due to the decay of picture brightness.

**Magnetic recording devices:** When a signal is recorded on a magnetic tape the record is permanent and can therefore be reproduced afterwards without any change of signal-to-noise ratio, reduction in bandwidth or echo due to the magnitude of the delay: long delays can therefore be obtained without any difficulty. The shortest absolute delays on a single track are determined by the minimum spacing between the recording and reproducing heads and by the tape speed. Shorter (relative) delays can be obtained by using two tracks and arranging the head spacing so that the difference between them corresponds to the desired delay. For very short delays however tape is not a very suitable medium as it is not sufficiently homogeneous; variations in thickness and elasticity causing variations in tape stretch and hence delay. The effects of wow and flutter also become important. For example, with a delay of 200  $\mu$ s at a tape speed of 38.1 cm/s (15 in/s) the difference between the spacing of the reproduce heads, for an in-line record head, would be 0.075 mm (0.003 in) and this would have to be maintained to a high degree of precision. This is very difficult and for accurate short delays it is necessary to use a drum with magnetic coating instead of a tape. In this case the heads are used out of contact with the recording medium, and a frequency modulation system is employed to overcome the consequent loss in signal-to-noise ratio and the effects of wow and flutter.



In autocorrelation it is necessary to be able to vary a time delay continuously over a wide range and magnetic recording lends itself admirably to this purpose. As used in B.B.C. Research Department<sup>20</sup>, for example, in measuring the sound insulation between two rooms, a smooth variation in delay between 100 ms and 250  $\mu$ s is required and this is obtained with a two track tape system.

Further applications are in ambio-phony<sup>21</sup> for delaying added reverberation to give the impression of a larger echo room and in an artificial reverberation machine<sup>18</sup>.

**Line store using capacitors:** In the capacitor line store the storage takes place in a group of capacitors which is approximately equal in number to that of the picture elements capable of existing in a line of the television picture. A different capacitor is connected to the incoming video signal during each picture element by a system of electronic switches and each capacitor is thus charged to a potential proportional to the amplitude of the input signal at the time of its connection. At the end of one line period all the capacitors have thus been charged and this information may be subsequently read out at any required time.

When used in a line store converter, the number of storage elements is theoretically twice the number of line harmonics which lie within the video bandwidth as phase and magnitude must each be taken into account.

After allowing for the fact that the position of the line occupied by blanking needs no storage, for practical filter design, the number used is 576. A similar number of input and output switches are therefore required.

The requirements for the switches are quite stringent, timing errors and those due to a potential difference between switches can both cause visible defects in the picture and should be below 5 ns for the former and -49 dB in the latter case. In addition, cross-talk due to resistance coupling must be held below -45 dB and that due to capacitive coupling below -16 dB.

The time constant of capacitor plus switch should exceed 10 ms if leakage is not to be a serious factor at 3 MHz. It is evident from these considerations that the design of appropriate switching is a major problem.

The size of a capacitor store of this type is about that of an enclosed bay and with the associated switching the cost is necessarily high and is about £10,000.

The main use for a store of this kind is in standard converters from 625 to 405-line and vice versa. A suggestion has also been made<sup>22</sup> that it could be used to synchronize two pictures when the timing error is less than one line and also to remove timing errors from the output of a video tape recorder.

Although reflections are not present in this type of delay, other sources of defects have been indicated. In practice these are

made so small as to be invisible in converting a 625-line picture to 405-line but are just visible when conversion the other way round is effected.

**Other possible developments**

**Quartz thread:** This is an extension of the wire delay line already discussed. One of the limiting factors of wire delay lines is that, as the attenuation is proportional to  $f^4$ , the high frequency range is limited. It has been suggested by R. E. Davies and G. D. Monteath and others that the wire should be replaced by a quartz thread. With this material the losses are proportional to  $f^2$  as there are no crystal boundaries to reflect the torsional waves. A line would have to be only about 0.5 mm in diameter to pass 10 MHz without the appearance of high order modes of transmission and it would be difficult to use piezoelectric transducers or normal magnetostriction drives. There is the possibility of using a short length of nickel wire as a Wideman form of transducer or of using coils of the Scarratt and Naylor type. If difficulty is found in making the coils as short as indicated by the formula given last month, i.e. up to half a wavelength long, it should be possible to use them in the range one wavelength to one and a half wavelengths. It appears that delays of up to 20 ms over a bandwidth of 10 MHz could be produced by this method.

**Transverse mode in wires:** The velocity of a transverse mode along a thin flexible wire or string is proportional to  $\sqrt{T/m}$  where  $T$  is the tension and  $m$  the mass for unit length. It will be seen that the velocity is independent of frequency, and this mode of propagation is therefore suitable for a delay line. These is also the advantage that the delay can be easily adjusted by changing the tension.

One of the simplest methods of driving the wire is to place it between the poles of a magnet and to pass a current along the wire. Other methods include moving coil, moving iron and piezoelectric transducers. The wire must be terminated in a mechanically resistive medium at the far end and means for applying a tension provided. Electrostatic transducers can be employed for extracting the signal at any position along the line and delays of up to 100 ms should be feasible for a line 1.5 m long.

Some protection would be required against building vibrations but this should not prove unduly difficult.

**Low velocity materials:** There are a few materials in which the velocity of sound is lower than it is in air and it is of interest to see whether these differences are great enough to be worthwhile exploiting in delay tubes.

**Liquid helium III:** This liquid has the lowest velocity of any liquid known, the value being less than one tenth of that of water. At the triple point the velocity is about 130 ms and therefore the length of a delay tube could be reduced to about a third of one using air as the conducting medium. The diameter would have to be reduced in

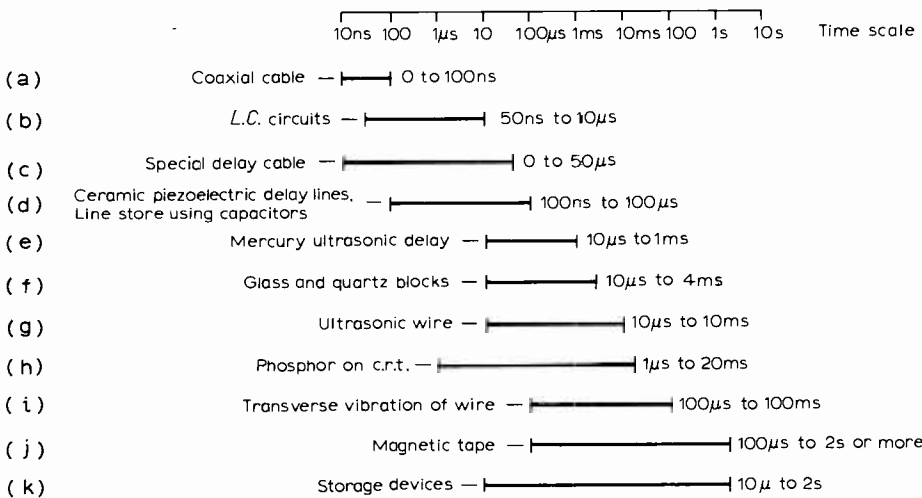

**Summary of time delays and performance.** (a) Coaxial cable—0 to 100 ns—cheap, low echo level, bulky for longer delays. (b) LC circuits—50 ns to 10  $\mu$ s—medium price, low echo level, compact, can easily be made to exact delay, variable length available. (c) Special delay cable—0 to 50  $\mu$ s—cheap, echoes can be troublesome, matching amplifiers needed. (d) Ceramic piezoelectric delay lines—100 ns to 100  $\mu$ s—cheap fixed delays. Line store using capacitors—100 ns to 100  $\mu$ s—very expensive, delay fixed. (e) Mercury ultrasonic delay—10  $\mu$ s to 1 ms—expensive but easy method of obtaining variable delay over wide bandwidth, associated equipment needed, echoes fairly low. (f) Glass and quartz blocks—10  $\mu$ s to 4 ms—expensive but only means of obtaining long delays over wide bandwidth. Associated equipment needed, echoes low, generally fixed delay. (g) Ultrasonic wire—10  $\mu$ s to 10 ms—medium price, medium bandwidth, high echo level, adjustable. Greater delays and bandwidths may be possible using quartz thread. (h) Phosphor on c.r.t.—1  $\mu$ s to 20 ms—expensive as associated equipment required, no definite cut-off so blurring of moving images occurs. (i) Transverse vibration of wire—100  $\mu$ s to 100 ms—cheap but would require development. Adjustable. (j) Magnetic tape—100  $\mu$ s to 2 s or more—medium price for a.f., expensive for TV. Adjustable delay. (k) Storage devices—10  $\mu$ s to 2 s—theoretically infinite delay, expensive, no echoes; extensive associated equipment needed.

the same ratio to avoid cross modes and would thus be about 0.3 in. A tube of this length and diameter could be coiled into quite a small volume but the necessary cryogenic apparatus would be very expensive.

**Uranium hexafluoride:** This is a substance which is produced in large quantities by the U.K.A.E.A. in the course of their activities and appears to have the largest atomic weight of any gas. The liquid boils at room temperature and the vapour is stable except that hydrogen fluoride is formed in the presence of water vapour; the radioactivity is quite low. The velocity of sound in the vapour is about 0.3 of that of air; the scaling factor with this medium would therefore be similar to that mentioned in the last section for liquid helium but the absence of cryogenic equipment would make the application much simpler. The high density would make the radiation impedance correspondingly large with a consequent increase in efficiency of the sound generators.

**Variable LC delay lines:** Reference was made last month to the Amtec LC delay line in which the capacitors consist of back-biased diodes whose capacitance can be varied by changing the bias. The available range of  $\pm 20\%$  in the delay cannot be utilized in practice owing to the changes in the impedance of the line with the bias applied and the consequent mismatch of the termination. For example, for a  $6 \mu\text{s}$  line the echoes from a matched line were about 40 dB below the main signal but when the delay was changed to  $5 \mu\text{s}$  the echoes were about 10 dB worse; the frequency response was also appreciably degraded. These effects can be overcome by employing two variable resistors, such as the drain-to-source impedance of a field effect transistor, as the source and load impedances of the line. A portion of the bias supplied to the line diodes is applied to the gates in such a way as to keep the termination correct over the whole range of adjustment. Other variable resistors such as light sensitive devices or thermistors could also be used for this purpose, the choice depending on the speed of response required. The variation in gain brought about by the change in termination can be taken up in a variable gain amplifier stage controlled by the same voltage.

**Ceramic piezoelectric delay lines:** It is possible to make the mechanical equivalent of the electrical lumped-constant low-pass filter type of delay line. In one form<sup>23</sup>, using a rotational mode, it consists of a series of spaced coaxial discs joined axially by a corresponding number of rods as shown in Fig. 8. The discs are the mechanical equivalent of the inductances and the rods of the capacitors in the electrical circuit and the velocity of propagation and the image im-

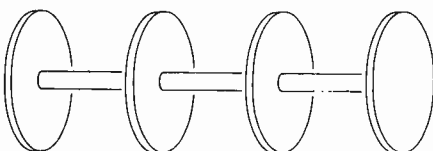

Fig. 8. Mechanical torsional delay line.

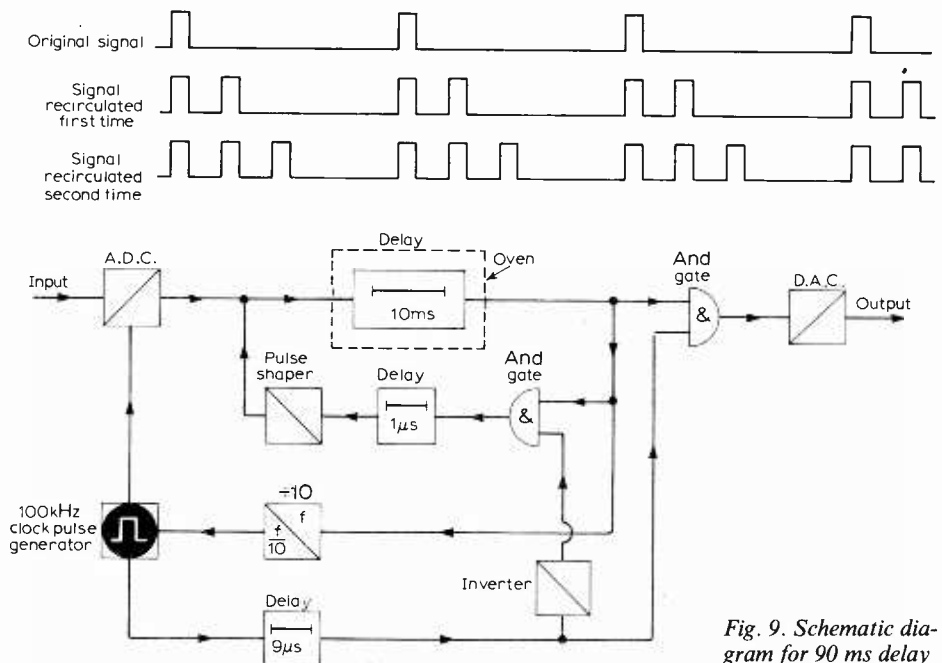

Fig. 9. Schematic diagram for 90 ms delay line by recirculation

pedance are given by corresponding expressions. Recently, however, the elements of such a line have been made of ceramic piezoelectric materials so that the device contains its own input and output transducers. At least one firm is experimenting with such a line for use in PAL colour television receivers but no details are available yet as to the performance achieved.

**Magnetic memory stores:** The use of these for delays can be regarded as an alternative to the capacitor store method. Unlike the capacitor store, however, the magnetic type is fully magnetised in one direction or the other and thus has the advantage of holding the recorded information indefinitely. On the other hand to use the magnetic type of store it is necessary first of all to digitize the signal and this appreciably increases the complexity of the auxiliary apparatus. Increased delay can be obtained by simply adding to the size of the store and this can be done without any of the difficulties such as attenuation, change in frequency response, signal-to-noise ratio or echo levels associated with other types of delay.

There are several types of magnetic store in production and developments in this field are so rapid that any survey is liable to be out of date by the time it is published. One type extensively used in computers consists of a series of minute ferrite rings about 450 microns in diameter with conductors threaded through a centre hole. Stores of this type can be made large enough to store a whole television field but in practice the read/write cycle time of 500 ns is too great for this application. On the other hand, a store of 36,000-bits would enable 100 ms of audio frequency programme to be handled and this would be adequate for some applications. Such a store would cost about £250.

A faster design has been brought out employing two cores per bit. This has a cycle time of about 300 ns but because of the added complication costs appreciably more than its simpler counterpart.

A second type of store was introduced by the Sperry Rand Corp.<sup>24</sup> It consists of a number of wires plated with an anisotropic magnetic medium with the hard direction of magnetization along the wire. On either side at right angles to the direction of the wires is a strip of conductor. The passage of current along the conductor causes the magnetic field in the wire to change direction. The strips are about 0.1 mm wide and are spaced about 1.5 mm between centres so the packing is about 80-bits to the square cm. The store, with a cycle time of about 150 ns, is fast enough for some television purposes. Very large stores, 16,000,000 bits, of this type are being developed; the cost per bit is expected to be less than ferrite by 1972.

**Active stores:** Metal oxide silicon transistors, (m.o.s.t.) and metal nitride silicon transistors (m.n.s.t.) have an insulated input electrode and this gives them an exceedingly high input resistance. The input capacitance is several picofarads and any charge deposited on this will therefore be held for a considerable time. The presence or absence of this charge can be determined by an examination of the current flowing in the output electrode and thus a nondestructive readout is possible. These stores are being developed by most of the semiconductor firms. The cost is expected to come down to about 1d or 2d per bit.

Another variety is the bipolar flip flop type. This is faster than the static capacitor type and clock rates of 50 MHz are feasible.

**Active networks:** One type of active delay system which seems to offer some promise is the resistance-capacitance all pass network. Sections of these networks are separated by operational amplifiers with a very high input impedance, a very low output impedance and unity voltage gain. A line of this type has been built by Standard Telephone Laboratories for the Admiralty to give a 700  $\mu\text{s}$  delay over a bandwidth up to 6 kHz and occupies a space of only 200 cm<sup>3</sup>. The line consists of 14 stages and uses thin



# Circuit Ideas

## Sine-wave power oscillator

This form of oscillator can give a considerable increase in power output compared with conventional oscillator circuits when using low-power transistors. A typical example is that of an OC72 type transistor giving a sine wave output at 50kHz with a power output of 1W. The circuit uses three separate inductors, there being no inductive coupling between them. The collector inductor  $L_1$  is tuned by  $C_1$ . The emitter inductor  $L_2$  forms part of the tuned circuit when the transistor is conducting and is in saturation. The third inductor  $L_3$  provides a drive current that is in phase with the collector current.  $C_2$  is a d.c. blocking capacitor.  $C_3$  in conjunction with  $D_1$  provides bias.  $D_1$  also prevents a large voltage appearing across the base/emitter junction during cut off as well as providing a path between  $L_1$  and  $L_2$  via

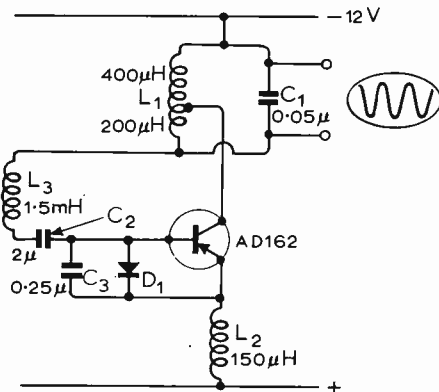

13-W 20-kHz power oscillator.

the collector/base diode as the output voltage is falling from positive to zero and cut off. The successful operation of the circuit is due to the fact that it is possible to control the collector current by the base current whilst the transistor is in saturation and that large currents can flow without exceeding the dissipation limit of the transistor. A typical saturation voltage is about 0.5V, and using an OC72 transistor it is possible to obtain a current of 125mA; and using an AD162, 2A. From the circuit it will be seen that  $L_1$  and  $L_2$  are in series to d.c. but in parallel to a.c., as the a.c. voltage appearing at the collector and emitter are nearly the same voltage when the transistor is in

saturation. The other ends of  $L_1$  and  $L_2$  are at the same potential a.c.-wise, both being earthy. The transistor is not tied to either positive or negative and can swing virtually unlimited above and below earth provided the transistor limits are not exceeded during cut off. Short circuiting the output stops oscillation and the current drops to zero until the short is removed.

H. L. ARMER  
Mastertape (Magnetic) Co. Ltd.,  
Slough,  
Bucks.

## 1000 : 1 attenuator

Three thumb-wheel switches can be connected as a 1000 : 1 attenuator with 1000 positions. The combination employs two 10-way 2-pole switches and one 10-way single pole switch. In the circuit

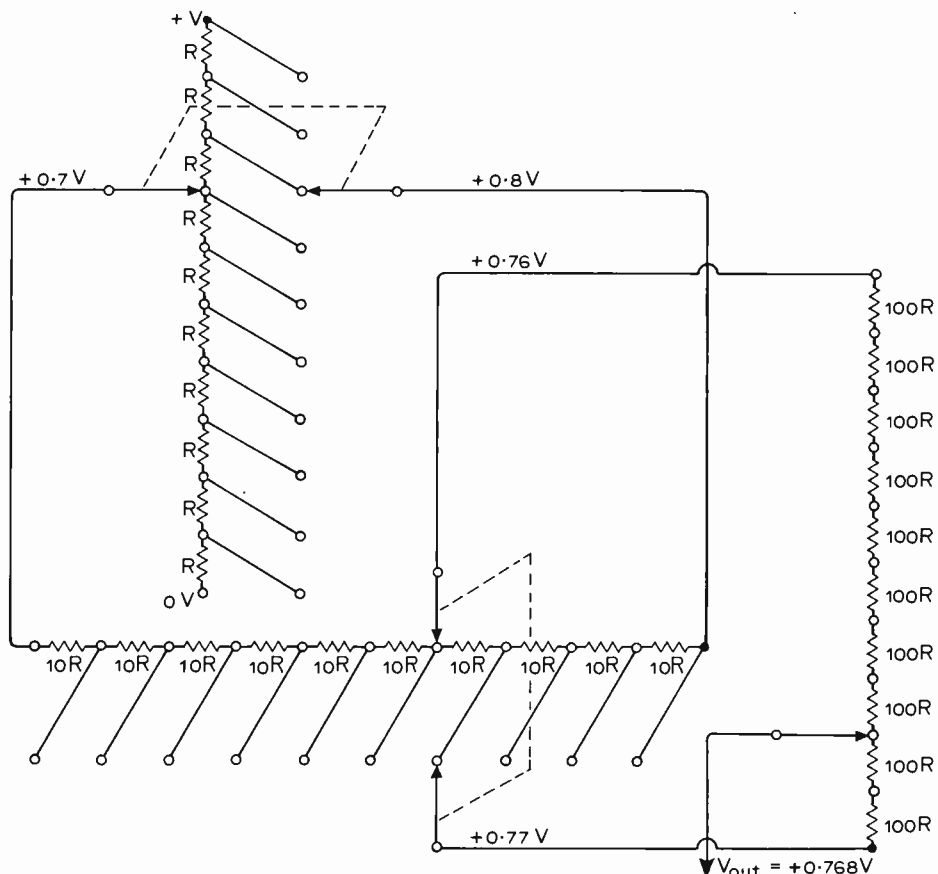

Thumb-wheel switch attenuator.

diagram the output has been set to 0.768 of the applied input voltage.

L. UNSWORTH  
Southport, Lancs.

## Unijunction square-pulse generator

The unijunction square-pulse generator circuit submitted by Mr. Paul (Circuit Ideas, March 1970) is rather unpredictable in its operation. In the circuit below, the timing capacitor charges via  $R_3$ ,  $R_4$  and the forward biased  $D_1$  from the supply. When the capacitor reaches the trigger voltage the unijunction goes into conduction. When this occurs, the positive end of  $C$  becomes

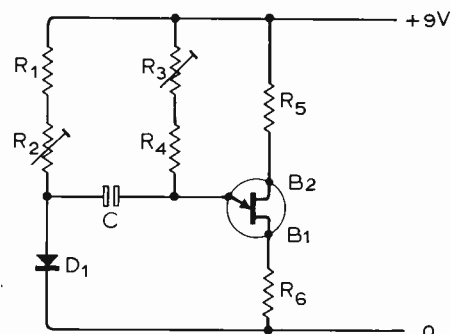

Unijunction pulse circuit.

referred to the negative of the supply and therefore  $D_1$  becomes reversed biased. The capacitor  $C$  can then only discharge via  $R_1$ ,  $R_2$ , the emitter-base junction and  $R_6$ .

P. J. GRANGER  
Sevenoaks, Kent.

# The Unijunction Transistor

## 2. Using the unijunction

by O. Greiter

Last month I discussed the properties of the double base diode, the unijunction transistor, with particular reference to its use in a very simple relaxation oscillator circuit. There are two reasons for treating this device in this way. First of all, this is how unijunctions are generally used—in one or other variation of the trigger and reset mode: secondly it brings out the character defects of the device—its dependence on temperature and supply voltage. Readers who have been around for twenty years will remember how we all began with common base class-A amplifiers when transistors came our way, and how we struggled to bias the first germanium junction transistors so that we could get the same answer two days running.

The discussion was limited, because it did not consider how we could extract the signal. There is our pulse, or our sawtooth, on the oscilloscope, but we want it to do some work—to be, as we say, at a prescribed power level. Taking out a pulse can be easy. If you are using the unijunction to control a thyristor (which is a very common way of designing controlled rectifier circuits) you simply set up the arrangement of Fig. 1(a). If you need to keep the two circuits isolated you can use a pulse transformer, as shown in Fig. 1(b). The value needed for  $R_1$  depends on the characteristics of the thyristor on the voltage available for  $V_{BB}$ , and on the capacitance. For G.E. thyristors the information is easily available in both their *Transistor Manual* and their *SCR Manual*.

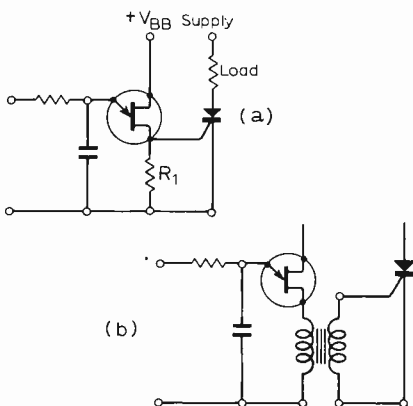

Fig. 1. (a) Unijunction triggering a thyristor with a common negative supply. (b) A pulse transformer may be used to separate the two circuits.

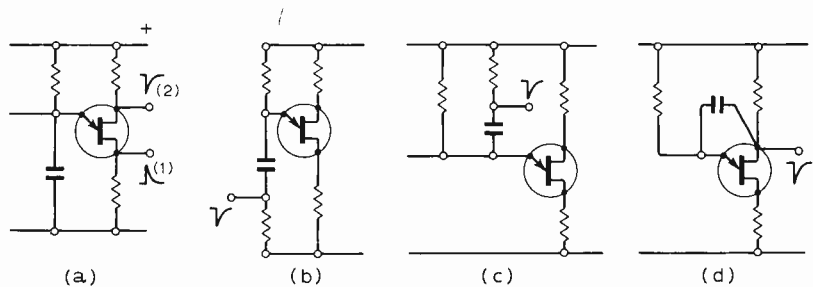

Fig. 2. Pulses are available in any of these five ways.

Curves show that when the capacitance is less than  $0.1 \mu\text{F}$  for the smaller thyristors and  $1 \mu\text{F}$  for the bigger ones, the necessary voltage gets squeezed between the limits of what the unijunction will stand and the minimum needed to get the extreme limit thyristor to turn on when it is really cold.

### Pulse points

Since we have started to consider pulse circuits, we may as well continue along the same line, but without the restriction of applying the pulses to a thyristor. Fig. 2 shows a number of possible outlet points, and indicates the corresponding pulse polarities. In (a, 1), (b), (c) and (d) the source impedance is relatively low, because it is essentially the capacitor discharge current which is presented at the output. In (a, 2) we have only the increase in base-two current, but the actual voltage may be higher. This is a relatively high impedance.

Whichever circuit is used there may be the need to buffer the unijunction system from what we may call the working load. The various low impedance circuits will offer us a pulse of about 2 V across  $20\Omega$  in circuits using  $0.1 \mu\text{F}$ , rising to 4 V in circuits using  $1.0 \mu\text{F}$ . We can feed this into a buffer transistor to get a very large output. The more powerful transistors in the TO-3 size, for example, can be driven to saturation at 100 mA with a drive of only 5 mA, which implies that we can put  $200\Omega$  in series between the trigger point and the transistor base. By keeping the amplifier input impedance well above the source impedance we reduce the chance that the transistor will affect the stability of the oscillator circuit. It is also possible to use this impedance section, if that is the right expression, to do some pulse shaping. Inevitably this implies

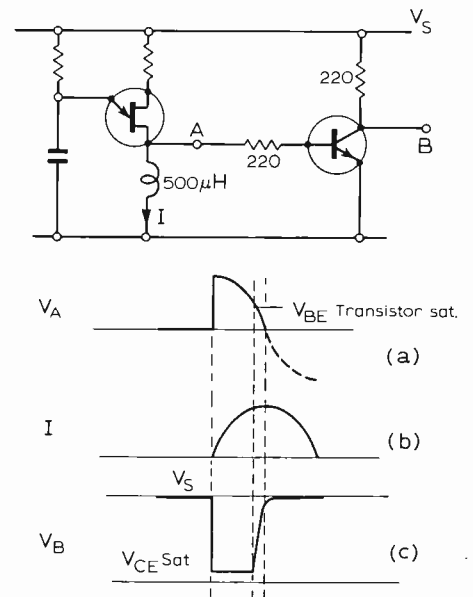

Fig. 3. The leading edge of the pulse at B (c) depends mainly on the speed with which the unijunction switches into the conducting state, and on the speed of the transistor. The trailing edge is determined by the transition of the LC "ring" across the base characteristic of the transistor. For a supply voltage of 10 V we should have  $V_{Amax} \approx 5 \text{ V}$  and  $V_{BE} \approx 0.25 \text{ V}$ . This would make the ratio of on-time to fall time about  $90^\circ/3^\circ \approx 30$ .

pulse lengthening. To get pulses shorter than the natural unijunction transistor fall-time it is necessary to differentiate or to use an edge-sensitive triggered circuit. One interesting form which gives a pulse with fast rise and fall times is shown in Fig. 3. In this circuit  $R_1$  is replaced by an inductor,

and for a particular example the rise and fall times were 0.3 μs with a pulse length of 11–12 μs. Replacing the inductor by a 47 Ω resistor gave a pulse rising in 0.3 μs but then falling in 3 μs. The pulse length is roughly one-quarter cycle of the natural frequency of the LC network, so that if we write

$$\begin{aligned} \omega^2 LC &= 1 \\ 4\pi^2 f^2 LC &= 1 \\ t &= \frac{1}{4}f \\ \frac{4\pi^2}{16t^2} LC &= 1 \end{aligned}$$

and  $L = 0.4t^2/C$ .

The rapid fall time is the result of the clipping action in the transistor. You cannot use an emitter follower.

A low frequency circuit in a hot environment is very awkward when, for some reason, short pulses are needed. To get the low frequency we use, we really must use, a fairly large value of capacitance. At high temperatures the fall time with a 1 μF capacitor is 30 μs, so that we must be prepared for a current pulse lasting 50 μs or more. There are situations in which this is not tolerable. One such situation is when the pulse is to drive units which are also used at higher frequencies and which are thus designed for short pulses. To avoid re-designing these parts of the system, and losing all the advantages of standardization, we must convert the long pulse into a short one.

The regenerative unijunction amplifier shown in Fig 4 will do this quite simply.

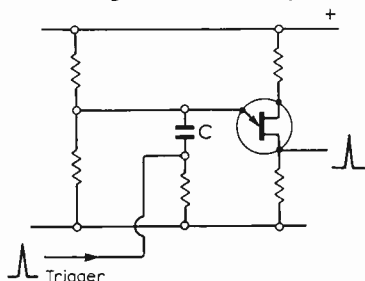

Fig. 4. Unijunction used as pulse repeater.

The capacitance here is small, so that the fall time is correspondingly low. The emitter is held by the voltage divider at just below the voltage  $\eta V_{BB}$  which will trigger the circuit.

**Pulling a sawtooth**

Although one might reasonably describe the output of a multivibrator as a pulse train it seems to me to be carrying classification too far. I propose, therefore, to leave the long-pulse unijunction circuits and turn to the immediate extraction topic, although now it will be a matter of extracting the sawtooth. Two very simple ways of doing this are shown in Fig. 5. The direct connection here is almost invariably safe because  $V_E$  drops only to around the valley points which is high enough to keep the n-p-n transistor in conduction and the p-n-p transistor clear of saturation. The input impedance of the emitter follower is the first disturbing factor to consider. It has a value

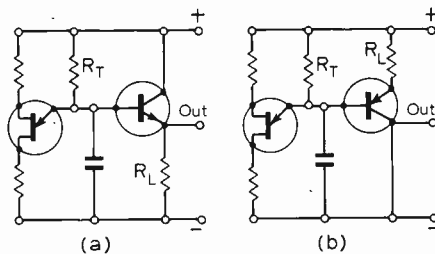

Fig. 5. The use of an emitter follower as sawtooth buffer amplifier.

of about  $h_{FE}R_L$ , and  $R_L$  must not be too large, because we want to do something with the sawtooth. In the circuit of Fig. 5(a) the term  $\beta R_L$  is part of a voltage divider with  $R_T$ , and if

$$\frac{\beta R_L}{R_T} < \frac{\eta}{1-\eta}$$

the emitter voltage will never reach the trigger point. Long before this condition is reached, however, the effect on the operating frequency and on the waveform will have been devastating. I find it easiest to make the rough calculations in the following way. Let us take a 20 V supply, and  $R_T = 30 \text{ k}\Omega$ .  $V_E$  will have an average value of about 5 V, so that the average current in  $R_T$  is 500 μA. Suppose the transistor has an  $h_{FE}$  of 100. For  $R_L = 1000 \Omega$  the base current will be 50 μA: for  $R_L = 10 \text{ k}\Omega$  the base current will be 5 μA. It does not matter all that much whether this current is added to the charging current through  $R_T$ , as it is with the p-n-p transistor, or subtracted, as it is with the n-p-n transistor. It is still a rather large proportion if we are concerned with good frequency stability. However, we must not overlook the unijunction emitter current in the region below the peak point. This is of the same order of magnitude, but of the opposite sign, and has about the same temperature coefficient. There is some possibility of matching these two currents, but I think that it will be much easier to use a really high value of  $R_L$ , the lowest possible value of  $R_T$ , and a second stage of amplification.

It is difficult to think of situations in which very high frequency stability is needed for a sawtooth which is not particularly linear. And if one has more than half an exponential rise it really is not the sort of linearity we are usually needing. A number of circuits have been devised to give better linearity: some of them I rather dislike. Four circuits are given in Fig. 6. The constant current circuit in Fig. 6(a) does not

provide a buffer output, but uses the transistor simply to charge the capacitance with a current of

$$(V_Z - V_{BE})/R_T$$

The frequency is not given by the expression roughly approximated as  $1/R_T C_T$ , but is readily calculated from the linear charging characteristic. Notice that it now depends sharply on the supply voltage, because the charging current is constant while the trigger point,  $V_p$ , is still  $\eta V_{BB}$ .

The two bootstrap circuits give a buffered output and use the output sawtooth to lift the charging voltage, keeping the voltage across the timing resistance nearly constant. With the zener diode we introduce a voltage which does not depend on the supply,  $V_{BB}$ , and the result is that variations in supply cause inverse variations in frequency. This does not happen with the capacitor bootstrap. The final circuit, Fig. 6(d), uses an integrating RC network fed from the emitter follower to add a concave-upwards voltage across  $C_{T2}$  to the normally concave-downwards voltage at the emitter of the unijunction.

The problem with these three circuits is that the need for a good big output at the emitter means a low value of emitter load resistance, and thus a rather heavy drain at the base. The relatively low cost of the circuits is a factor which must not be overlooked. The oscillator can easily be synchronized to a more stable source. Operational amplifiers can be used to give a really linear sawtooth. These are cheap bread-and-butter circuits which show the swings and roundabouts trade-off which is normally encountered with this class of circuit.

**Triggering with the unijunction**

Pulse generators (and we have seen that the unijunction transistor is an excellent choice for the active element in a pulse generator) are widely needed to trigger binary counter stages. The use as a regeneration amplifier is fairly obvious, and this is an area of interest in slow counting problems. Binaries are also used as square wave generators. The advantages of using an independent trigger and a resistance coupled pair rather than a multivibrator are the ease with which the frequency can be varied and the exact equality of the two halves of the waveform. Unless the highest stability is needed the triggering arrangements can be very simple. Fig. 7 shows the two versions, for n-p-n and p-n-p transistors. It is important in the design of this

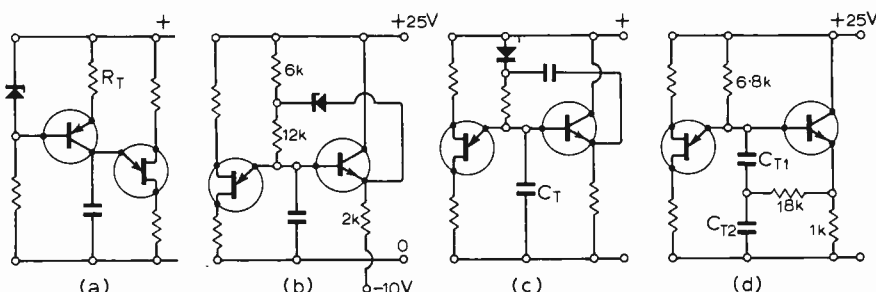

Fig. 6. Linearization circuits for sawtooth generator: (a) constant current; (b) zener bootstrap; (c) capacitor bootstrap; (d) integrator feedback.

type of circuit to ensure that the transistors are not oversaturated—so that the trigger pulse can lift the emitters to cut-off—and to ensure that there is enough drive—that is a big enough timing capacitor. It is not very difficult to get this system to work at around the 50 mA level.

If the timing resistance is returned to one of the transistor collectors rather than to one positive line, either of the circuits in Fig. 7 can be used as a single-shot timer. The initiating pulse is fed to the other transistor and must be such that it drives the end of the timing resistor positive. This rather involved wording covers both the p-n-p and n-p-n systems. After a time of about  $C_T R_T$  (about meaning the  $\eta$ -dependent factor) the unijunction will trigger

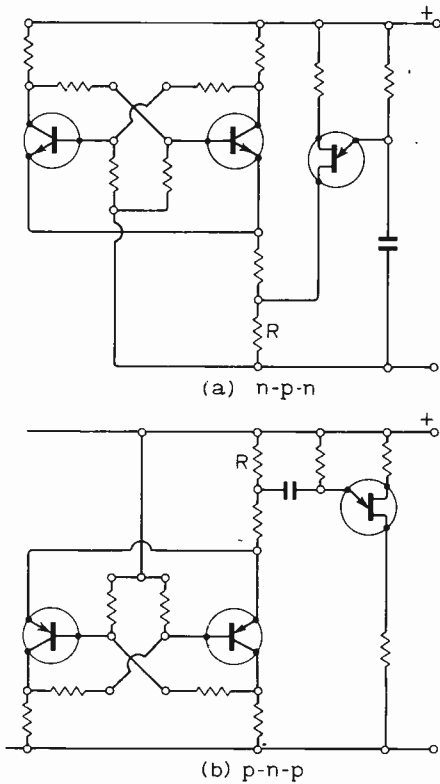

Fig. 7. Triggering a simple bistable pair from a unijunction transistor. Small "memory" capacitors are needed across the two collector-base feedback resistors. The emitter current pulse in R must knock the "on" transistor off.

and the system will return to its original state. If precautions are taken to fix the low level of the unijunction emitter this arrangement has virtually no memory and the shot time does not change significantly with the duty cycle.

**Frequency division, low-level current detection, and long-term timing**

The simplicity of the unijunction relaxation oscillator circuit, the fairly high stability of its frequency and the fact that it is a non-linear system combine to make it a very attractive frequency divider. If we consider one basic relaxation oscillator, in its simplest form of Fig. 2(a), we know that the emitter voltage rises exponentially towards the supply voltage until it reaches a value

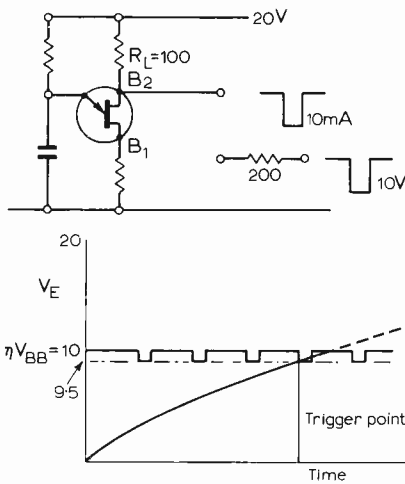

Fig. 8. Triggering a divider.

of  $\eta V_{BB}$ . In order to have some numbers to talk about, let us take  $V_{BB} = 20$  V and  $\eta = 0.5$ . Then, forgetting the need for a fraction of a volt to get the peak current through, the emitter will trigger at 10 V. Let us take the value of the resistance from base 2 to the positive supply as 100  $\Omega$ . We inject into this resistance an extra 10 mA, so that  $V_{BB}$  looks like 19 V. If the emitter has reached 9.5 V it will trigger. The pattern is shown in Fig. 8. Once the circuit triggers it is completely re-set and the whole process repeats itself.

Although it is not too difficult to make the calculation an exact one, an approximate approach gives a reasonably reliable answer and shows the solvent features more easily. If the run-up were linear, it would be at the rate of  $\eta V_{BB} f$  volts per second, where  $f$  is the natural frequency of the divider. For a division ratio of  $n$ , the critical moment is  $1/nf$  seconds before the natural trigger point, when the emitter voltage will be  $\eta V_{BB}/n$  below triggering. The pulse applied to B2 must be less than  $V_{BB}/n$  if it is not to trigger the oscillator. If the pulse is a bit bigger than this, the triggering will take place after  $n-1$  pulses instead of after  $n$ . If the pulse is more than twice this size

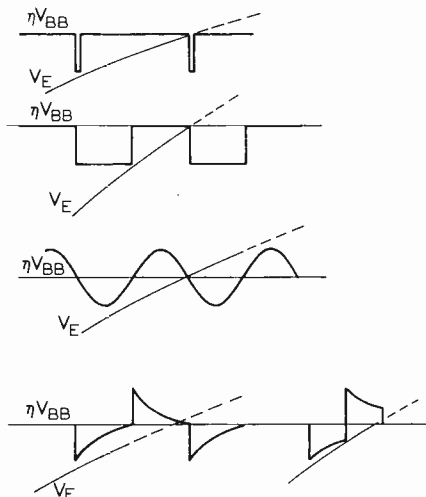

Fig. 9. Triggering details for pulse, square-wave, and sine-wave locking. If the square wave is roughly differentiated we can even (as shown on the right) get an improvement over pulse behaviour.

we shall divide by  $n-2$ , or even worse.

This is an order of magnitude calculation for dividing with a trigger pulse. If we are triggering from a square wave we must avoid the trailing edge of the triggering signal. With a sine wave the ideal, which is not shown in Fig. 9, is that the slope of the sine wave should equal the slope of the emitter voltage. For a sine wave of  $A \sin 2\pi nft$  the slope is, at its maximum,

$$A \cdot 2\pi n f$$

and thus  $A = V_{BB}/2\pi n$ , provided that the locking signal is applied at B2. The least critical situation of all is to use a square wave with capacitance coupling to get a pulse top running parallel to  $V_E$ .

One source of a negative locking pulse is, of course the emitter of a preceding unijunction oscillator. The capacitor needed to couple this point to the base 2 of the

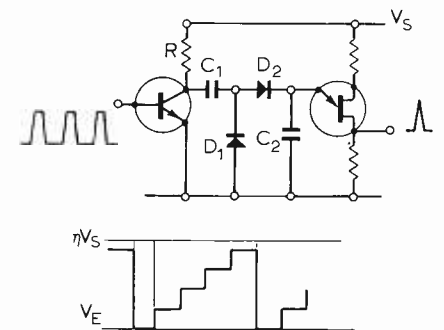

Fig. 10. Diode-pump divider.

following stage then forms part of the timing circuit. With transistors at their present prices the simplicity of a buffer amplifier is almost certainly worth the extra couple of shillings.

Any detailed design must take into account the stability of the locked oscillator itself. If this is taken as 1%, and if the supply voltage is also held to 1% in order to stabilize the size of the locking pulse it is plausible to talk about division ratios of 50 : 1, and realistic to think about 20 : 1.

This type of frequency divider is essentially a constant frequency type (Fig. 10). One application is for use with a crystal oscillator, to obtain a low frequency of very high stability. The unijunction is also useful for dividers of the diode-pump type. Each input pulse raises the emitter voltage by  $V_s C_1 / (C_1 + C_2)$ , until the emitter reaches  $\eta V_s$ . The unijunction triggers, and discharges  $C_2$  to re-set the pattern. The drive pulse must be long enough for  $C_1$  to be cleared out through  $D_1$  and the transistor, and the space between the pulses must allow  $C_1$  and  $C_2$  to reach equilibrium through  $R$  and  $D_2$ . The loss of charge by  $C_2$  due to diode and unijunction leakage is the limitation on the low frequency end, but within the limits set in this way the circuit will be independent of frequency. A more complicated version, obtained by adding a bootstrap amplifier, gives equal steps in place of the steadily diminishing ones familiar to all diode-pump users.

Closely related to the frequency divider circuits are some circuits which have very high sensitivity and can be triggered by very small input currents. The peak point current

of a unijunction is somewhere in the range 2–20  $\mu\text{A}$ , depending on the price you pay and on your luck. Confining our attention to a unit with  $\eta = 0.5$  operated at 20 V we see that in a relaxation oscillator designed for very low frequencies a resistance of 5.1 M $\Omega$  in the emitter supply will never be able to get the emitter junction quite over the top. As it is not too convenient to use timing capacitances much above 1  $\mu\text{F}$ , timing circuits are limited to the odd second or two. It is therefore necessary to separate out the circuit which supplies the peak point current from the CR circuit which does the timing, so that the timing resistance does nothing but charge the capacitance.

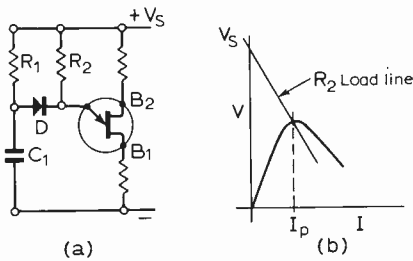

Fig. 11. (a) Heart of long period timer, and (b) steady state unijunction characteristic.

The essential features are shown in Fig. 11. The resistor  $R_2$  is of the order of 10–20 M $\Omega$ , if the expensive low-leakage type of unijunction transistor is used. This is chosen to hold the emitter at its peak point, as shown in Fig. 11(b). Typically the current,  $I_p$ , will be 1  $\mu\text{A}$ . As it stands this is a perfectly stable situation. The timing capacitance  $C_1$  is charged through  $R_1$ , and for most of the time the diode  $D$  is reverse biased. Obviously  $D$  must be a very good diode. If  $C_1$  is 1  $\mu\text{F}$  and  $R_1$  is 1000 M $\Omega$  the time constant will be 1000s, about a quarter of an hour.  $C_1$  must have a leakage resistance of at least 10,000 M $\Omega$  for this situation to make sense.

As it stands, this circuit will not work. When the voltage across the capacitance equals  $\eta V_s$  the diode will be ready to come into conduction, but the net load line in Fig. 11(b) will shift only slightly as  $R_1$  appears in parallel with  $R_2$ .

At this stage one frequency divider technique comes into play. When a pulse is injected, in the way shown in Fig. 8, the emitter voltage remains at its original value, while the unijunction peak voltage is moved down. The only stable intersections for  $V_E > V_{BB}$  is away on the rising part of the characteristic where the current is tens, or

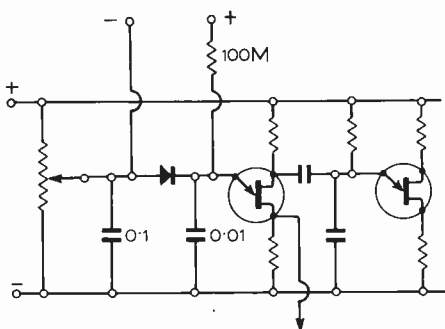

Fig. 12. Very sensitive current detector.

hundreds, of mA. The main timing circuit triggers in the ordinary way. It might be feared that one could get a marginal situation in which each quick test of the circuit just took away enough leakage to hold the  $C_1$  voltage on the threshold. The look lasts only the odd  $\mu\text{s}$ , however, and if we are timing 1000s we should hardly look more often than once a second. The wastage duty cycle is too small to worry about. The test pulses are, of course, produced by another unijunction oscillator, using a cheap unijunction. Time delay circuits of this kind are normally used to trigger a thyristor, either directly from base one or through a trigger transformer. There is no reason why the pulses, at one a minute or one an hour, should not operate a binary, or a ring counter, to produce a sequence which switches regularly at these intervals.

The technique used to detect a very small current is similar to the long period timer. The circuit, this time with the test pulse generator included, is shown in Fig. 12. Both capacitors charge quickly to a voltage set by the potentiometer. This must not be high enough for the circuit to trigger. If current is fed in through the 100 M $\Omega$  resistor at the top of the diagram it will lift the emitter voltage and at the next test pulse the circuit will trigger. As soon as the 0.01  $\mu\text{F}$  capacitor has supplied the full peak point current and the trigger operation is under way, the 0.1  $\mu\text{F}$  capacitor will be able to discharge and provide a healthy pulse at base 1.

All the circuits discussed so far have been designed to have one stable state. The action of the circuit consists of moving the working points into an unstable region, whereupon the triggering is followed by a resetting operation. Like all negative resistance systems the unijunction circuit provides a negative resistance only in a limited current range and unlike some negative resistance circuits can be safely operated outside these margins. An example of a negative resistance which is not safe is a power transistor up in the avalanche or second breakdown area. This is bounded on the upper side by the small positive resistance of a total loss. With the unijunction we can construct a bistable element. The distorted-in-scale unijunction characteristic is shown in Fig. 13(a) and the circuit which goes with it in Fig. 13(b). The load line for  $R_1$  and  $V_1$  intersects this characteristic in three points, so long as  $V_1 < \eta V_E$ , and neglecting the effect of  $R_2$  and  $R_3$ . The intersection in the negative resistance region, at B, is not stable, but the other two intersections, at A and C, will be stable. Notice that C is to the right of the valley point. We have

$$V_1 < \eta V_E$$

$$I_C > I_V$$

Rather roughly, since  $V_{valley}$  is small

$$R_1 < \eta V_E / I_V$$

A typical value of  $R_1$  would be 1–2 k $\Omega$ . This gives a safe dissipation level at C. The transition from one state to the other is easy. If we are at A, a positive pulse applied to the emitter, or a negative pulse applied to B2, will unlatch the system, leaving only an intersection in the region of C. If the circuit

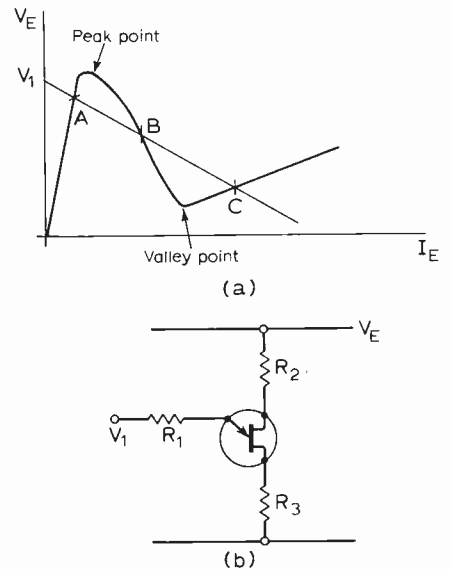

Fig. 13. (a) Bistable load line. (b) Bistable circuit.

is at C, a negative pulse at the emitter will drain off current to leave only one intersection, somewhere below A. By using Thevenin's theorem in reverse we can establish the emitter conditions for a bistable in the way shown in Fig. 14.  $R_4$  is small and is there to detect the changeover. Suppose that  $R_3$  is a 1- $\Omega$  resistor and that the effective value of  $V_1$  is just 1 V below the peak point. The current through  $R_3$  will be in the region of 5 mA. Let us use  $R_3$  also as the return path for another piece of equipment which shares the negative line, but not necessarily

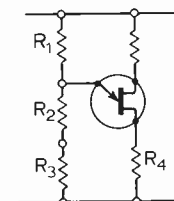

Fig. 14. Single supply bistable.

the positive line, with the circuit of Fig. 14. Should this outside system pass more than about 1.5 A, the emitter will be lifted up to above  $V_p$  and the circuit will trigger. A capacitor connected to the emitter can be added to give some extra current when triggering first takes place, although this will slow down the detection process. If the capacitance is across  $R_2$  a sharp rise in  $I_{R3}$  will get straight through to the emitter. The pulse at  $R_4$  triggers the shut-down device. Just how delicate you care to make this arrangement is a matter of detailed design. A 1-V margin is very robust indeed.

To monitor for the absence of a signal  $R_2 R_3$  can be replaced by a transistor. So long as the base is held positive the circuit stays at point A. Loss of the voltage at the base will cut off the transistor and trigger the circuit.

The uses of this bistable in ring counters, and one or two other applications of the unijunction, will be taken up in a later article, which will also describe the programmable unijunction transistor. This is an attractive variant, which has many advantages and, unfortunately, some disadvantages when compared with the ordinary unijunction transistor.



# Electronic Building Bricks

## 3. The electron and how it moves

by James Franklin

So far we have talked about electrical energy (Part 2) and about the electron (Part 1). The connection, if the reader has not already realized it, is that electrons are the "stuff" by which electrical energy becomes evident as such. Electrical energy can be understood intuitively because it can be experienced and seen in action—but what exactly is the electron?

The sad truth is, that although a multi-million-pound industry is built on what you can do with the electron, nobody really knows what it is. We only infer that the electron exists from certain natural phenomena which have been observed and measured.\*

Basically the concept is that the electron is the smallest unit of what we call electricity, and is also one of the constituents of all atoms. A familiar, simplified picture of electrons in an atom is shown in

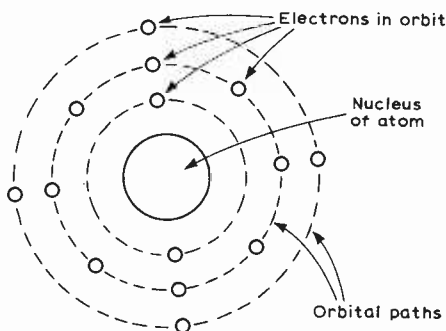

Fig. 1. Simplified diagram of an atom of silicon, an element used to make transistors. (The orbits of the electrons round the nucleus are not actually in the same plane and concentric as shown.)

Fig. 1. As such the electron is represented as a particle. But a particle of what material? According to our theory of the structure of matter, all materials are made up of atoms and the atom is the smallest possible unit of any element. Something which is only a constituent of the atom cannot therefore be a particle of recognizable substance. If it is not a thing, perhaps it is an event. At any rate we will agree that it is an entity. Whatever its real nature, the electron has mass—the same familiar property as possessed by a cricket

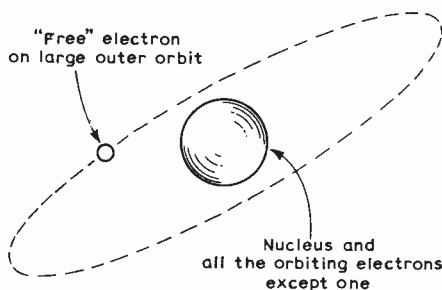

Fig. 2. Atom with "free" electron travelling in large, outer orbit. (For simplicity the inner electrons and nucleus are shown as a solid sphere.)

ball. (And, in fact, the electron can be made to behave in much the same way as a cricket ball—propelled, accelerated, decelerated, brought into collision, deflected and stopped.)

When we say "the smallest unit" we mean the electron is the smallest unit that can be used as a measure of quantity of electricity. (Analogy: in a quantity of ball bearings the smallest unit into which the total weight or volume could be divided is a single ball bearing.) Quantity of electricity is called *charge*, so the electron is the basic unit of electric charge. A larger and more practical unit by which charge can be measured is the coulomb†, which is  $6.24 \times 10^{18}$  electrons. A stationary charge is one form of electrical energy—*potential energy*. As such it can be used to represent static information (Part 2).

A more easily understood property of electricity is the electric current—one thinks analogously of a current of water. An electric current is, in fact, a general

† Named after the French physicist and engineer Charles Augustin de Coulomb (1736-1806).

movement of many electrons—a process known as conduction. It takes place freely through certain materials, such as copper, less freely through others such as water, and hardly at all through others such as nylon. This brings us back to the dual role of the electron as a small quantity of electricity and as a constituent particle of atoms. The atoms of good electrical conductors, such as copper, have "free" electrons travelling in large, outer orbits, as shown in Fig. 2; these are not fully engaged in holding together the atoms of the material, and so are available to take part in the process of electrical conduction. In a cubic centimetre of copper there are about  $10^{23}$  such "free" electrons.

Considered in detail the process of conduction is extremely complicated. It is something like what happens in a tightly packed crowd of people in a room with a door at each end (Fig. 3) if fresh people keep pushing in at one door. As each fresh person pushes in all the people already in the room are forced to change position slightly—in random directions according to where little spaces open up around them—but the net result of all this movement is that people nearest the far door are pushed out of the room.

In a piece of material in which conduction is occurring, each free electron of an atom moves into the nearest "space" in an adjoining atom (made available by a free electron moving elsewhere). The pattern of movement in a small volume is random, but over the whole material there is an aggregate of movement in a given direction. This movement of electrons is another form of electrical energy—*kinetic energy*—and, as we saw in Part 2, can be used to represent dynamic information.

When we speak of the "speed of electricity" we mean the speed of the aggregate movement—that is, the speed at which a disturbance (e.g. "switch-on", the start of electron movement) travels through the material. This speed varies slightly with different materials but is about  $3 \times 10^8$  metres per second.

When we speak of "current" we mean the *rate* of aggregate movement—that is the total number of electrons moving in a given direction past a certain point in a given period of time. Since, then, electric current is really electron flow rate, it could be measured in electrons per-second, but in practice coulombs-per-second are more convenient. A current of one coulomb ( $6.24 \times 10^{18}$  electrons) per second is called an ampere,‡ or "amp".

‡ Named after André Marie Ampère (1775-1836), French physicist and mathematician.

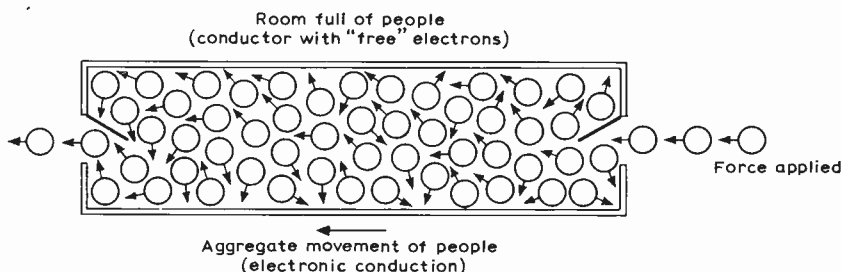

Fig. 3. Human-cum-mechanical analogy of the movement of electrons in a material.

\* The idea of the electron was conceived by the Scots physicist Sir Joseph Thomson. He announced it at the Royal Institution, London, in April 1897.

# Letter from America

The alleged TV radiation hazard is still provoking arguments here and set-makers are all claiming that *their* sets are harmless anyway . . . As I said before, it's not the radiation that worries me—it's the programmes! Sylvania recently announced details of a high-voltage multiplier device which is said to significantly reduce radiation in colour sets. As a bonus they also say it reduces the chance of fire! The device consists of diodes and capacitors housed in an epoxy enclosure and it replaces the high-voltage rectifier and shunt regulator. Many readers will note the similarity to the EY52 ladder network which supplied the high-voltage potential (25kV, if my memory serves me right) to the old Mullard TV projection tubes. I still have one of the original Schmidt lens systems which I brought across the Atlantic 'in case I could use it for something'. But there it sits gathering dust in the basement—occasionally to be shown to an American unbeliever.

Talking about tubes reminds me of the fantastic new camera tube from RCA. This uses the Silicon Intensifier Target (SIT) with a built-in electronic light amplifier. Basically, it consists of a vidicon-type scanning electron gun and image intensifier separated by a special silicon target with an integrated circuit consisting of no less than 600,000 p-n junction diodes. A brightness magnification of 150,000 is easily achieved enabling a bright television picture to be produced from very low ambient lighting. In fact, it is claimed that useful pictures can be picked up from a scene that is illuminated by a light level equivalent to that supplied by a 100-watt bulb two miles away! Obviously, such a tube will have many industrial and military applications but could be used for ordinary broadcast purposes where the reduction in studio lighting would be very much worth while. Fig. 1 shows a cross-section through one of the diodes. Three types of tube are available at the moment—16, 25 and 40mm.

Morgan Electronics, of Chicago, have released details of an interesting automatic telephone answering system suitable for high-speed voice and data transmission. The recorder/transcriber is a modified Uher U-5000 and the idea is to record at a very low speed (15/16 i.p.s.) transmitting and receiving at a high speed and then playing back at the original speed. Thus,

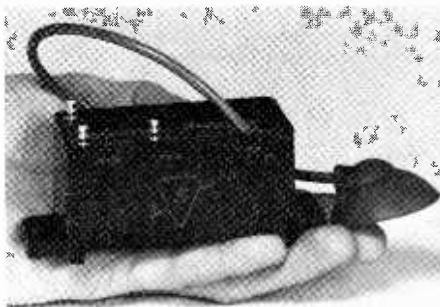

(A) Sylvania's voltage multiplier which reduces radiation in colour television sets.

transmission time and telephone charges are reduced considerably. Reproduction is said to be better than normal 'phone conversation as connections are made direct to the 'phone circuits, by-passing the hand receiver. Features include automatic level control, a three-digit index counter, full remote control of tape motion and a single button on the microphone for selection of replay and rewind functions so that information can be added or errors corrected.

Quadraphonic sound is still the big topic in audio circles and I suppose at least 70% of the exhibitors at the July Consumer Electronic Show in New York's Americana

and Hilton hotels will be demonstrating some kind of 4-channel sound. Among the contending systems are Harman-Kardon's 'Orban' synthetic idea which uses reverberation and phase-shifting networks, the Hafler which is a fairly simple matrix system, and the Dorren and Feldman systems—both multiplex. Several disc systems are being developed but so far the only one to leave the lab. is the Scheiber which has been demonstrated to various groups including the Audio Engineering Society. Like the Harman-Kardon, it is a synthetic or *psycho-acoustic* system. In other words, although it definitely produces four discrete channels the sound may not be an accurate reproduction of the original performance. RCA are backing the 8-track cartridge for their first venture into the quadraphonic market and they say at least 30 tapes will be on sale in August. Complete systems (tape player, radio and four speakers) were demonstrated back in May. Motorola and Lear-Jet are also putting their faith in the 8-track (Quad-8) format, but Wollensak have just announced a 4-channel cassette recorder! Almost every maker of reel-to-reel machines—Sony, Teac, Telex, Crown, etc—have 4-channel models, although, as yet, few tapes are available apart from Vanguard's series of 14. Fisher will be demonstrating a new 4-channel receiver at the Consumer Show. This is model 701 which is rated at 40 watts (genuine r.m.s. watts) per channel.

While all this flurry and excitement over quadronics has been going on, news has come from Mexico of—wait for it—*stereo on a.m. in the medium wave-band*. It seems that station XTRA down in Tijuana, just across the border, has been broadcasting real, genuine two-channel stereo on 690 kHz using a new system with one sideband handling the left channel and the other carrying the right. The only snag is that two receivers are needed, one tuned higher than normal, and the other lower. (I'd hate to ask my wife to do that!) The result, according to L. R. Kahn, XTRA president, is "true stereo performance."

G. W. TILLET

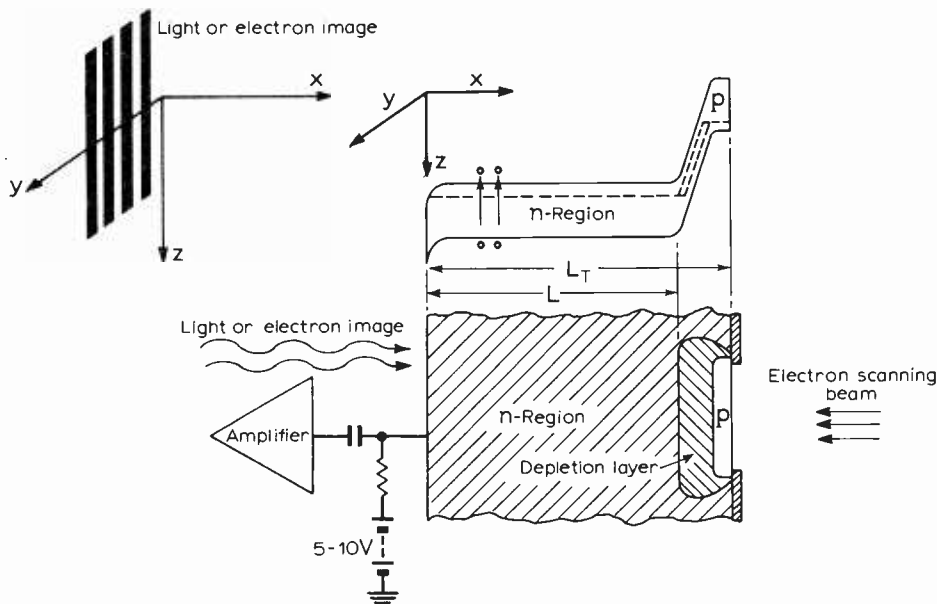

Fig. 1. Target cross-section through one diode of the RCA silicon intensifier tube.

# World of Amateur Radio

## International prefixes

Until recently, the national prefix, used compulsorily by all amateur stations since 1928, has had as its primary purpose the immediate identification of the country from which the station is transmitting. Lately, however, this seems to play a secondary role to that of attracting special attention as a result of novelty. The Canadians used 3C, instead of VE, to mark their centenary, now AX and ZM respectively replace VK and ZL to celebrate the discovery of Australia and New Zealand by Captain Cook. European "liberation" anniversaries have been marked by 3Z (Poland), OM (Czechoslovakia) and YT (Yugoslavia). Russian club stations have all been allocated new call signs, all having the prefix UK but with a country identification concealed in the number or call-letters. Many amateurs must by now be saying "enough" to this form of organized chaos, and hanker after the days when a prefix was a prefix was a prefix!

## Encouraging c.w. operation

Despite the increased use in recent years of s.s.b. on the h.f. bands and the domination of the various telephony modes on v.h.f., hand Morse remains a basic and popular element of amateur radio communication. Because of the possibility of extreme narrow-band reception (of the order of 25 to 50 Hz bandwidth) which is becoming more practicable with the better stability of transmitters and receivers, c.w. continues to offer considerably more scope for weak signal operation than any alternative mode, as well as largely overcoming the language barriers to international communication. But increasingly, apart from maritime and some military communications, the pool of professionally experienced operators is shrinking.

A group of c.w. enthusiasts which, for over 30 years, has aimed at encouraging the use of Morse, and raising the standards of operating (though not without running into some controversy in so doing) has been the "First Class C.W. Operators' Club". Membership of this club is limited to 500. Currently there are members in more than 50 countries. The club imposes a rigorous system of

nominations for membership—every new member has to be recommended by at least five sponsors from at least two continents. Members are expected to be able to operate at speeds of not less than 25 words per minute and to be able to operate on at least two bands. Members are encouraged to work between 25 and 35 kHz from the low-frequency limits of the bands. Secretary of the club since 1967 has been W. H. Windle (G8VG), 121 Laburnum Avenue, Dartford, Kent.

## R.S.G.B. "Radiocom 70"

With the amateur radio exhibition this year moving forward in the calendar to August 19th-22nd (Royal Horticultural Society's New Hall, Greycoat Street, London S.W.1) several new features are being introduced, in addition to the normal trade and club exhibits. Vouchers totalling up to £50 are to be awarded for outstanding mobile and portable station performance as judged by contacts with the exhibition stations which will be active on 3.5, 70 and 144 MHz. This contest, under the jurisdiction of Phil Thorogood (G4KD), the exhibition organizer, requires application forms to be obtained in advance from R.S.G.B., 35 Doughty Street, London WC1N 2AE. There is also to be a competition for the best club-constructed equipment. Small "mini-stands" are being introduced both for the trade and to allow non-trade members to exhibit or sell equipment. The traditional "draw" will be for a Hammarlund HQ215 transistor communications receiver.

## Band activities

During a sporadic E opening associated with a severe solar storm on June 12th-13th TF3VHF, the 2.5W Icelandic beacon station on 70 MHz, was heard for the first time by many British stations. A 144-MHz 'first' established during this period was a link between Scotland (GM3EOJ) and the Faeroes (OY2BS). The solar storm introduced a signal black-out on some h.f. bands (reported particularly from the United States), and conditions on h.f. continued patchy for most of the remainder of the month,

though this may have been due to the normal summer increase in signal attenuation in the D layer. The 144.950-MHz beacon station near Dundee, GB3ANG, is again operational. The first new Nigerian licence for five years has been issued to Kaduna Polytechnic (5N2KPT). One of the most active amateur television groups in the United States is the Indiana Amateur TV and UHF Club whose members are now operating some 15 amateur television stations, with pictures regularly received over distances of 50 to 200 miles. This group includes W9NTP who (apart from his slow-scan work described in the March issue) operates a 300-watt u.h.f. transmitter with a 64-element collinear aerial array mounted at a height of 50 ft. There now appear to be only two countries (Cambodia and Vietnam) that retain their objections lodged with I.T.U. to international amateur radio operation by their citizens; but for many years there seems to have been little or no amateur licensing by China.

## Mobile rallies

With British mobile licences now reported as past the 3000 mark, good attendances are expected at the August mobile rallies. These include: R.S.G.B. National Mobile Rally (9th) at Woburn Abbey (talk-in stations GB2VHF, G3VHF and GB3RS on 144, 70 and 1.8 MHz); Derby (16th) at Rykneld School, Bedford Street; Swindon (23rd) at No 15 M.U., and R.A.F. Wroughton, near Swindon; Preston (30th) at Kimberley Barracks, Deepdale (talk-in stations on 1.8 and 144 MHz). Firms interested in exhibiting at the Wroughton rally should get in touch with G. Windsor, 26 St. Gregory's Road, Deepdale, Preston.

**In brief:** A. C. Morris, G3SWT, recently became honorary treasurer of the R.S.G.B. following the resignation, due to ill-health, of Norman Caws, G3BVG. One of his immediate concerns will be an "extraordinary general meeting" of the Society in August, called to authorize an increase in subscriptions. . . . The annual convention of the International Amateur Radio Club will be held in Geneva from September 16th to 18th (I.A.R.C., P.O. Box 6, 1211 Geneva 20, Switzerland). . . . As a result of the recent appeal seven Cheshire Homes now have amateur-band receivers. The Homes Amateur Radio Network Fund would welcome the offer of amateur equipment in reasonable working order (offers to W. M. Clarke, G3VUC, 66 Fillace Park, Horrabridge, Yelverton, Devon). . . . What must surely be an exceptionally amateur radio conscious family has been noted recently by A.R.R.L.: comprising grandfather (W8BU), grandmother (WA8EBS), son (WA8ZOD), son-in-law (W8WJC), daughter-in-law (WA8ZOC) and two grandsons (K8TND and WA8ZOA).

PAT HAWKER, G3VA

# Personalities

**W. E. Hobbs** has been appointed manager of the Marconi Electro-Optical Systems Division, at Basildon, of which he was formerly technical manager. He succeeds **J. E. H. Brace** who has resigned. Mr. Hobbs joined Marconi in 1952, working in the Research Department on colour television. In 1954 he moved to the Broadcasting Division and in 1957 to what was then the Closed Circuit Television Division. In 1962 he became development group leader responsible for the development of the vidicon colour camera and the large screen colour projector. A year later he was made deputy development manager, and since 1965 has been technical manager of the Electro-Optical Systems Division where for the past two years he has been responsible for the development and production of the Martel missile system. **M. B. House** succeeds him as technical manager of the Division. Educated at Queen Mary College, London University, Mr. Howe joined Marconi in 1951 as a development engineer. He worked in the Broadcasting Division, first on film scanners and television film recorders, and later on vidicon cameras until he joined Closed Circuit Television Division in 1959. He was appointed development manager in 1968.

**Colin Yendell** has been appointed product sales manager of the Semiconductor Division of Auriema Ltd, representatives of several American semiconductor manufacturers, the main one being Philco-Ford. Prior to joining Auriema Mr. Yendell was with Marconi-Elliott Microelectronics at Witham as commercial manager of the bipolar i.c. product group.

**Alexander M. Poniatoff**, founder and chairman of the board of directors of Ampex Corporation, is to retire as chairman on August 25th. He will continue to direct the Alexander M. Poniatoff Laboratory, a specialized research and development organization within Ampex. Mr. Poniatoff founded Ampex (originally Ampex Electric and Manufacturing Company) in

1944. Ampex, which takes its name from his initials plus EX for excellence, was originally formed to produce electric motors and generators for World War II navy radar systems. In 1946, Mr. Poniatoff decided to devote the small company's efforts to development work in the experimental field of magnetic recording. Born in Russia in 1892 Mr. Poniatoff studied mechanical engineering and received an M.E. degree at the technical college, Karlsruhe, Germany.

**Henri Busignies**, senior vice-president and chief scientist of International Telephone and Telegraph Corporation, has received the Award in International Communication of the I.E.E.E. "for his outstanding leadership and technical contributions in the fields of electronic technology and communication techniques". An authority on radio navigation and radio direction finding, Dr. Busignies has been associated with I.T.T. for more than 40 years. The annual award consists of a plaque, certificate and \$1,000. Dr. Busignies developed the high-frequency radio direction-finding system, known as "huff-duff", used in World War II against enemy submarines. He also invented moving target-indicator (MTI) radar.

**James Redmond**, F.I.E.E., director of engineering of the B.B.C., has been elected president of the Society of Electronic & Radio Technicians. Mr. Redmond joined the Council of the Society in 1965 and was elected vice-president in 1968. He succeeds Sir Ian Orr-Ewing, Bt. O.B.E., M.A.

**H. G. Maguire**, general manager of the Marconi International Marine Co. Ltd., since January 1962, has been appointed a director of the company. He began his career with Marconi when he joined as a seagoing radio officer in 1927. He served at sea until 1936, when he won promotion to the shore technical staff at the Glasgow depot. In 1943 he was promoted to

inspector and transferred to Montevideo, returning to Glasgow in 1946. He became Liverpool depot manager in 1951, and moved to the company's head office at Chelmsford in 1955 to take over as manager of the newly formed export sales division. Mr. Maguire is also a director of Norsk Marconikompani, A/S, Oslo, and of Coastal Radio Ltd.

**T. B. McCrirrick**, F.I.E.E., F.I.E.R.E., is to be the new chief engineer, radio broadcasting, in the B.B.C. on the retirement of **A. P. Monson** who joined the Corporation in 1933 as an engineer in the London Control Room. Mr. Monson's appointments have included those of head of the transcription recording unit, superintendent engineer (recording), superintendent engineer (radio broadcasting), and since 1963, chief engineer, radio broadcasting. Mr. McCrirrick joined the B.B.C. in 1943 and after serving in studios in Edinburgh, Glasgow and London, he transferred in 1949 to the Television Service where he was latterly engineer-in-charge, television studios, and head of engineering, television recording. He left the Television Service in 1969 on his appointment as head of studio planning and installation department. **C. R. Longman**, F.I.E.R.E., Mr. McCrirrick's successor, joined the B.B.C. in 1943 and has been with the Television Service since 1950. Since 1967 he has been head of engineering, television studios, in which position he is succeeded by **R. B. Mobsby** who has been with the B.B.C. since 1943 initially at the Tatsfield Receiving Station and for the past 15 years in the Television Service. He has been head of engineering, television network, since 1967.

**R. Monger**, who was until recently in charge of digital voltmeter development in Dynamco, has joined Racal Instruments Ltd as chief engineer, d.c. measurements. Racal also announce the appointment of three other senior engineers—all of whom have been with Racal several years. They are **P. Sample**, chief engineer (r.f. measurements); **G. Taylor**, chief engineer (pulse and digital instruments); and **E. W. Parker**, group leader, product engineering group.

**E. Ribchester**, B.Sc., F.I.E.E., who joined British Communications Corporation Ltd (now one of the Racal group of companies) in 1966 and became chief engineer two years ago, has become technical manager. Mr. Ribchester was previously with the G.E.C. where he was at one time associated with the team working on colour television.

## BIRTHDAY HONOURS

Among those upon whom honours were conferred on H.M. The Queen's birthday were:

### Knights Bachelor

**David C. Martin**, C.B.E., executive secretary, the Royal Society.  
**Arnold Weinstock**, managing director, General Electric and English Electric Companies.

### C.B.

**E. V. D. Glazier**, Ph.D.(Eng.), B.Sc., M.I.E.E., director, Royal Radar Establishment.

### C.B.E.

**W. D. H. Gregson**, assistant general manager, Ferranti (Scotland) Ltd.

### O.B.E.

**D. J. Harris**, B.Sc., Ph.D., M.I.E.E., lately professor and head of electrical engineering, Ahmadu Bello University, Zaria, Nigeria.  
**A. P. Monson**, chief engineer, radio broadcasting, B.B.C.  
**T. S. Robson**, M.B.E., assistant director of engineering, I.T.A.  
**J. Sieger**, chairman and managing director, J. & S. Sieger Ltd.  
**Wing Cdr. R. H. Smith**, M.I.E.R.E., R.A.F.  
**F. N. L. Williams**, head of school radio broadcasting, B.B.C.

### M.B.E.

**D. R. Cockbaine**, M.I.E.R.E., British Technical Asst. Officer, Turkey.  
**Major J. Drennan**, M.I.E.R.E., Corps of R.E.M.E.  
**M. Johnston**, engineer-in-charge, Post Office Radio Station, Baldock.  
**G. D'A. Prichard**, manager, information services, Hirst Research Centre.  
**E. A. Rust-D'Eye**, telecoms technical officer, Ministry of Defence.  
**D. H. A. Scholey**, F.I.E.R.E., lately engineer-in-chief, East African Posts & Telegraphs Corp.  
**T. Shepherd**, formerly project leader, C. & W. Bahrain Earth Station.  
**J. W. N. Yeomans**, chief engineer, Redifon Air Trainers Ltd.

## OBITUARY

**Kenneth Joseph Ayres**, managing director of International Aeradio Ltd, died on 4th June aged 48. He served as a navigator in the R.A.F. Bomber Command from 1942 to 1945 when he transferred to air traffic control becoming senior air traffic control officer at the R.A.F. Elementary Flying School, Hullavington, and subsequently at Flying Training Command Headquarters. In 1947 Mr. Ayres joined International Aeradio as an air traffic control officer and after serving at a number of stations overseas became air traffic services manager at the company's headquarters. He was appointed deputy general manager, and then general manager, technical services, and in June 1968 was elected to the board of directors. He had been managing director since August last year.

# New Products

## Trimmer Capacitor Range

Two ranges of trimmer capacitors manufactured in the U.S.A. by the JFD Electronics Corporation are now available in the U.K. from ITT Components Group Europe. These are the DV-5 and MVM series of capacitors. The DV-5 series of subminiature ceramic-disc variable capacitors employs special ceramic materials in a monolithic structure. The capacitors occupy about 1mm of printed circuit board space. Six models are available covering a minimum of 2.5pF to 9pF capacitance up to a maximum of 5pF to 30pF. Working voltages are 100V d.c. from -55 to +85°C and 50V d.c. up to +125°C, with an insulation resistance of  $10^{10} \Omega$  at 25°C at the rated voltage. The MVM series of microminiature air variable capacitors is designed for high frequency applications that demand extreme stability, small size and a high  $Q$  factor. The working voltage for each of the four models is 250V d.c. with an insulation resistance of  $10^{12} \Omega$  at 500V d.c. and 25°C. ITT Components Group Europe, Capacitor Product Division, Brixham Road, Paignton, Devon.

**WW324 for further details**

## Low Input-current Op.Amp.

An encapsulated amplifier, type E75, has been added to the 'E' range of compatible amplifiers by Comtec. Fitted with an f.e.t. differential input stage, it has an input impedance of  $10^{13} \Omega$  and an input bias current of 1pA. Common mode rejection is 66dB with a voltage range of  $\pm 10V$ . The open loop gain is  $5 \times 10^5$  dB, and the output level  $\pm 10V$



at  $\pm 10mA$  from  $\pm 15V$  supplies up to 20kHz. Using silicon devices throughout, the amplifier is encapsulated in epoxy resin and is housed in a plastic case 38mm square and 15mm thick. It is fully protected against short circuits from output to ground and input to supply rails. Computing Techniques Ltd, Westminster Bank Chambers, Bridge Street, Leatherhead, Surrey.

**WW326 for further details**

## Low-noise S-band Transistor Amplifier

Watkins-Johnson has developed an S-band transistor amplifier with a noise figure of 7dB. Designated WJ-5004-4, the amplifier delivers a power output (for 1dB gain compression) of +5dBm and small

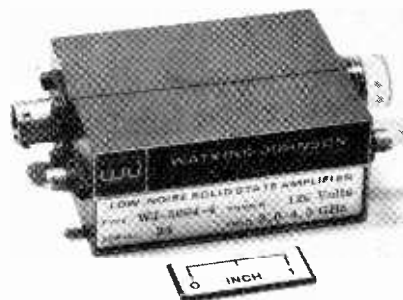

signal gain of 25dB. The overall design is consistent with the environmental requirements of MIL-E-16400F, and MIL-E-5400K, class 2. Watkins Johnson International, Shirley Avenue, Windsor, Berks.

**WW320 for further details**

## Electroluminescent Diodes

Latest additions to Plessey's range of electroluminescent diodes are two red light emitting types, designated GPL 1 and GPL 2. Both types are based on single crystal gallium phosphide which gives particularly good performance at low operating bias—typically brightnesses at 10mA of 765 cd/m<sup>2</sup> (GPL 2) and 306 cd/m<sup>2</sup> (GPL 1), corresponding to a luminous flux of 3 and 1.2 millilumens respectively. Guaranteed optical powers

are 120 and 40 microwatts for the two types. Continuous operation is possible up to 25mA with increased brightness, and pulsed operation of the diodes is possible up to 1A subject to a mean dissipation of 50mW. The response time is 300ns. The Plessey Company Ltd, Microelectronics Division, Optoelectronic and Microwave Unit, Wood Burcote Way, Towcester, Northants NN12 7JN.

**WW327 for further details**

## V.H.F./U.H.F. Power Transistors

Three power transistors for v.h.f./u.h.f. class C amplifiers have been introduced by RCA. Two of the devices, designated the 2N5914 and 2N5915, are incorporated in a radial-lead stud package and are designed for stripline or lumped-constant circuits. The third device, designated the 2N5913, is built into a three-lead TO-39

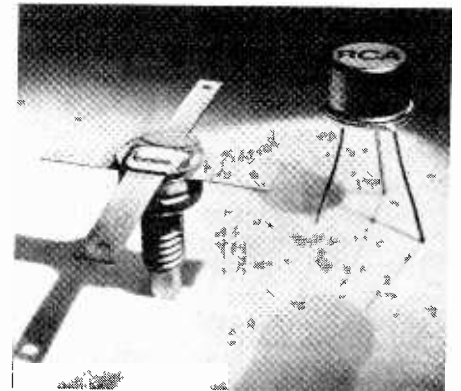

type package. All three devices are epitaxial silicon n-p-n planar transistors with an overlay emitter electrode construction. Typical ratings of the 2N5913 device at 12.5V is 2W at 250MHz (9dB gain) and at 8V is 1.5W at 250MHz (7dB gain). These devices are available from Electronic Components Division, RCA Ltd, Sunbury-on-Thames, Middlesex, and from RCA's distributors in the UK: Semicomps Northern Ltd, ECS Ltd and REL Equipment and Components Ltd.

**WW319 for further details**

## Triple Output Power Supply

A triple output, stabilized power supply is announced by Oltronix. The unit—designated B60-IT—has output ranges of 0-6V, 0-30V and 0-60V at 4, 2 and 1A respectively. Stability is 0.005% or 1mV for 10% line change. Noise is 0.05mV r.m.s. Recovery time from 100% overload is 50μs. Environmental temperature coefficient is less than  $\pm 100ppm/^\circ C$ . Adjustment is provided by a 10-turn potentiometer which gives a dial reading of the chosen output voltage to an accuracy of  $\pm 250mV$  on the 30V and 60V ranges and  $\pm 25mV$  on the 6V ranges. Range selection is by front panel switch which simultaneously indicates selected voltage and current, potentiometer scale factor and full scale value for the output monitoring meter. This is a

dual meter which shows voltage and current on separate scales. Also on the front panel are constant-voltage and current-limit indicators, monitoring-meter range expansion push buttons, a control for setting the current limit between 10 and 110% of rated output and graphs of voltage/current characteristics. A new overvoltage protection circuit is incorporated on the six-volt range which clamps the output at 7V and automatically resets to the chosen output after an overvoltage condition is cleared. A sensor lights a "hot" lamp on the front panel and switches the supply off if a long high voltage condition occurs. Input can be 110, 117, 220 and 235V a.c.  $\pm 10\%$ , 50-60Hz. Dimensions are 165mm long  $\times$  133mm high  $\times$  228mm deep. Oltronix UK Ltd, Hunting Gate, Hitchin, Herts.  
**WW323 for further details**

### 5W, 7 to 12.5GHz Pulsed Gunn-effect Diode

An X-band high power pulsed Gunn-effect diode, Type TEPO 1, has been introduced by Plessey to their range of pulsed and c.w. Gunn diodes. Power outputs are available in the frequency range 7 to 12.5GHz. Typical operating conditions are bias voltages from 25 to 40V, and currents in the range 2 to 5A and an efficiency of about 5%. The maximum pulse repetition frequency is dependent on the pulse length—e.g. for a 0.5 $\mu$ s pulse the maximum p.r.f. is 10kHz. Fast switch-on of the device is possible if the full supply voltage can be fed to the Gunn diode in about 1ns. The device is suitable for operation in a waveguide or coaxial cavity, and is available in a standard S4 package. The Plessey Company Ltd, Microelectronics Division, Optoelectronic and Microwave Unit, Wood Burcote Way, Towcester, Northants NN 12 7JN.  
**WW325 for further details**

### Potentiometer for P.C. Boards

An addition to Plessey's MP range of moulded carbon-track potentiometers, designated type MP WT, has been specifically designed for use with 0.1in (2.54mm) grid printed circuit boards, and its 3.175mm long pins conform to this configuration. This potentiometer offers 0.25-W rating at 70°C, with standard resistance values from 1k $\Omega$  to 2.2M $\Omega$ . A wide range of non-standard values is also



available. The Plessey Company Ltd, Resistor Division, Cheney Manor, Swindon, Wilts.

**WW322 for further details**

### Mobile Radio Test Set

Marconi Instruments have introduced a versatile mobile radio test set which combines in one unit, many functions normally only found in a number of different instruments. This compact instrument, type TF 2950, is operated from rechargeable internal batteries. It can be used to check, service and calibrate a.m./f.m. mobile radio equipment designed for the frequency ranges 65-180 MHz and 420-470 MHz, with maximum transmitter powers of 15W continuous or 15-25W short term. The 65-180 MHz range is covered in three steps.

The instrument is composed of a signal generator, an audio-frequency voltmeter,

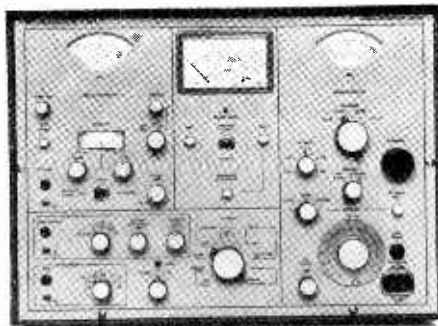

a modulation monitor, a power meter and an audio-frequency oscillator. The voltmeter measures between 0 and 300mV in four ranges and 0-10V in three ranges. The modulation monitor measures amplitude and frequency modulation over the same ranges as the signal generator but in two bands instead of four. The amplitude modulation depth measurement range is 0-80% and f.m. deviation is measured in two ranges with maximum readings of 5kHz and 25kHz. The power meter measures both forward and reflected power up to 15W continuously, and up to 25W for short periods. The audio-frequency oscillator generates a 1kHz signal variable by  $\pm 1\%$  and its output can be chosen from one of four ranges between 0-3V and is indicated on the main meter. Battery state is also shown on the main meter. Price of the TF 2950 is £800 f.o.b. U.K. It weighs 16kg and measures 315  $\times$  420  $\times$  230mm. Marconi Instruments Ltd, St. Albans, Herts.  
**WW336 for further details**

### U.H.F. and I.F. TV Transistors

Four new transistors from SGS cover the requirements of the u.h.f. converter and i.f. amplifier stages of single- or dual-standard TV receivers. All are encapsulated in TO-72 packages. The two u.h.f. types, the BF272 and BF316 are intended for grounded base operation and have standard connections. These two devices, by using a p-n-p configuration, are

claimed to give a performance not previously equalled by silicon transistors. The main advantage is the low noise figure—typically 3.5dB at 800MHz—added to very low reverse transfer capacitance ( $C_{rb}=0.09$ pFmax) giving a high power gain (13dB typical at 800MHz) with adequate stability. The two v.h.f. devices—BF270 and BF271—are intended for grounded emitter operation and have the base and emitter connections reversed, resulting in reduced feedback capacitance and isolation of input from output circuits, giving improved stage gain. The BF270 is for use as an a.g.c. i.f. amplifier giving a stability limited gain of 28dB at 36MHz and an a.g.c. control range of 60dB with low base-current drive requirements. The BF271 is designed for the final i.f. amplifier stage. Its power dissipation (240mW at 25°C ambient) allows more than adequate output without excessive temperature rise and non-linearity. It has a gain of 28dB at 36MHz. SGS (United Kingdom) Ltd, Planar House, Walton Street, Aylesbury, Bucks.  
**WW321 for further details**

### Gain-tracking T.W.T.

Latest addition to the series of ITT gain-tracking, low-noise travelling wave tubes is type W3MT/4A. Tubes already available cover the frequency ranges 2-4 and 4-7.5 GHz, and the W3MT/4A now extends this range from 7.5 to 12 GHz. Gain varies over the operating frequency band from 30 to 36 dB and all tubes follow a mean gain-with-frequency curve to within  $\pm 1.5$ dB. A fixed input voltage of +1,300V with respect to earth is required, plus 6.5V d.c. supply for the cathode heater. Saturated output power is +7 to +17 dBm and noise less than 15dB. ITT Components Group Europe, Valve Product Division, Brixham Road, Paignton, Devon.

**WW332 for further details**

### Reversible Decade Counters

A reversible, or up/down, counter module type DCM1711, announced by Quarndon Electronics, incorporates t.t.l. logic i.cs and a numerical indicator tube to provide readout. It is intended for industrial control and counting applications at up to 15MHz in either direction. A carry/borrow circuit provides a zero-sense output for sign change purposes. Another decade counter, model DCM1709, will operate up to 10MHz and an alternative version of this module,

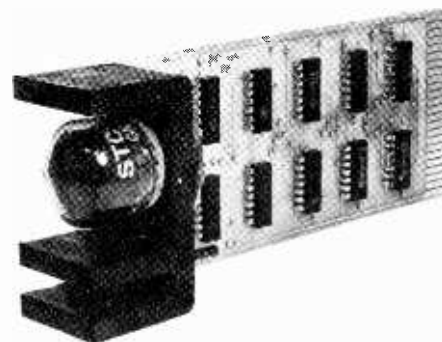

the DCM1708, is wired with a discrete component display decoder to improve the clarity. Quarndon Electronics (Semiconductors) Ltd, Slack Lane, Derby DE3 3ED.

**WW334 for further details**

## R, C and L Boxes

A wide range of resistance, capacity and inductance boxes are available from Lionmount & Co. Ltd, having one to five decades. Resistance boxes cover the range  $0.1\Omega$  to  $11M\Omega$  with an accuracy of 0.1%:

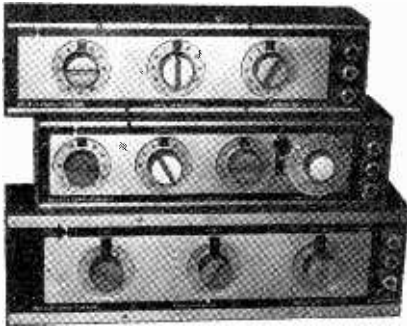

capacitor boxes span the range  $8pF$  to  $111\mu F$  and inductance boxes using ferrite materials are available up to  $11H$ . Lionmount & Co. Ltd, Bellevue Road, New Southgate, London N.11.

**WW339 for further details**

## Miniature Zener Diodes

Latest additions to the Mullard range of miniature components are some zener diodes with voltages of 5.6 to 12V. Called type BZX84, the new diodes are intended for use with thick and thin film circuits, but they can also be used with advantage in many other applications. The BZX84 diodes have a voltage tolerance of  $\pm 5\%$  and a dissipation rating of  $150mW$  at an ambient temperature of  $25^\circ C$  when mounted on a ceramic substrate  $5 \times 5 \times 1$  mm. The maximum permissible forward current is  $100mA$ , and the thermal resistance  $0.5^\circ C/mW$ . Mullard Ltd, Mullard House, Torrington Place, London, W.C.1. **WW333 for further details.**

## M.O.S. Shift Registers

Two new m.o.s. static shift registers are available from Plessey. The MP220B can be programmed on a package pin to be either 80 bits or 56 bits long. Data-stream select logic is incorporated on the input to the register, thus facilitating recirculation of data. The device also features an equivalence gate enabling data in the final bit to be compared with external data, and an appropriate output derived. The device is available in either flat pack or d.i.l. packages. The MP225B is a 100-bit static shift register which also incorporates data-stream select logic on the input. The device is available in a TO-5 package. Both devices operate from d.c. to  $1MHz$  over the temperature range

$-20$  to  $+70^\circ C$ , and interfacing with t.t.l. can be achieved with a few discrete components. The shift registers are completely compatible with the MP100 series m.o.s. logic. Microelectronics Division, Plessey Components Group, Cheney Manor, Swindon, Wilts. **WW330 for further details.**

## Reference Voltage Cell

A robust miniature reference cell which can be soldered to a printed circuit board has been introduced by Muirhead. Designated type K-391-A, this new cell is claimed to have performance characteristics equal to those of the best reference cells available. It measures only  $70mm \times 11mm$ , and can be mounted or transported in any position. The e.m.f. is  $1.019$  to  $1.0193V$  at  $25^\circ C$  and the temperature coefficient ( $10$  to  $40^\circ C$ ) is less than  $-3\mu V/^\circ C$ . Each cell is supplied with a certificate of test with e.m.f. stated to the nearest  $10\mu V$ . This value is traceable to the National Physical Laboratory Volt with an estimated uncertainty not exceeding  $10\mu V$  (0.001%). Muirhead Ltd, Beckenham, Kent.

**WW335 for further details**

## Digital Probe

A pocket-size digital probe has been announced by Aircraft Supplies. It is suitable for on-the-spot checking of electronic equipment and it replaces the oscilloscope where this instrument is unavailable or inconvenient to use. The probe is light and easy to handle and is powered by rechargeable nickel cadmium cells. There are two modes of operation: as an indicator of static logic levels (0 and 1 corresponding to lamp on and off respectively); and as an indicator of pulse trains. Retail price is  $\pounds 19$  15s. Aircraft Supplies Ltd, 506 Wallisdown Road, Bournemouth, Hants.

**WW338 for further details**

## Miniature Tape Recorder

The Nagra SN miniature tape recorder, available from Hayden Laboratories, will fit into a coat pocket, has a signal-to-noise ratio (relative to 2% 3rd harmonic

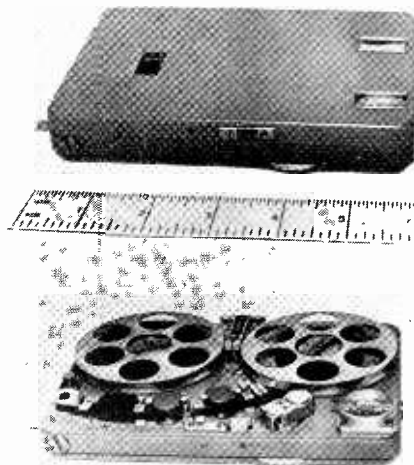

distortion) of  $60dB$ , and a frequency response of  $80-16000Hz \pm 2dB$  at  $3.75$  i.p.s. Average speed stability is  $\pm 0.5\%$ , and wow and flutter  $\pm 0.1\%$  at  $3.75$  i.p.s. The recorder uses  $3.81mm$  (0.15in) tape and will play for 52 minutes at  $1.875$  and 26 min at  $3.75$  i.p.s. Power can be supplied from manganese batteries, alkaline sealed accumulators, or from an optional mains operated power supply. An omnidirectional capacitor microphone ( $48 \times 18 \times 10mm$ ) is also available as an extra. Price of basic recorder is  $\pounds 365$ . Hayden Laboratories Ltd, East House, Chiltern Avenue, Bucks.

**WW337 for further details**

## Watchkeeping Receiver

A new watchkeeping receiver for use on the international  $2182kHz$  R/T distress frequency is available from Redifon. Designated R.492, the receiver is crystal controlled, simple to operate, and compact. It is completely independent of other radio



equipment and can be preset to a volume low enough to avoid annoyance, while still producing full volume whenever a two-tone alarm signal is received. A receiving range control provides adjustment of the receiver to suit the particular aerial in use. Protection against damage to the receiver input circuits from powerful signals is provided by a fast-acting muting system. An external speaker output is provided. The receiver operates from a ship's main a.c. supply or from a  $24V$  d.c. source. Redifon Ltd, Broomhill Road, Wandsworth, London, S.W.18.

**WW329 for further details**

## High-level Gate-turnoff S.C.R.s

Transitron has introduced a series of high-level gate-turnoff thyristors. Design features of the new devices—designated RTGD02—include pulse turnoff up to  $5A$ ; typical  $5A$  turnoff gain of  $10-15$ ; typical turnoff time under  $5\mu s$ ; and operating temperatures up to  $125^\circ C$ . Repetitive peak-off-state voltages and repetitive peak reverse voltages for the five devices in the range are: RTGD0206,  $60V$ ; RTGD0210,  $100V$ ; RTGD0220,  $200V$ ; RTGD-

0230, 300V; and RTGD0240, 400V. Absolute maximum ratings include (at 80°C) average on-state current, 1A; r.m.s. on-state current, 1.6A; peak one-cycle surge current (60Hz), 10A; peak reverse gate voltage, 5V; peak gate power, 500mW; and average gate power, 100mW. Packaging is in standard TO-5 cans. Transistron Electronics Ltd, Gardner Road, Maidenhead, Berks.

**WW331 for further details.**

## 64-pole P.C.B. Connector

A sixty-four-pole electrical connector for the indirect connection of printed circuit boards has been introduced by ITT Components Group Europe. The GO7 connector is designed for use with the ITT Standard Equipment Practice (ISEP)

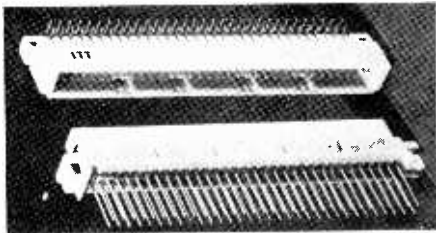

system and complements the existing ISEP connector range. Within the connector's overall length of 94mm (3.7in), sixty-four contacts are arranged in two rows of thirty-two with a contact pitch of 2.54mm (0.1in). By the use of external coding pins, polarization without loss of contact is possible. The connector is available to special order equipped with only thirty-two poles, either in line on one side or staggered. ITT Components Group Europe, ITT Manufacturing Services Division, Equipment Practice Sales Office, Edinburgh Way, Harlow, Essex.

**WW311 for further details**

## 2-GHz Transistor

TRW Semiconductors Inc. has added another member to its GHz transistor family—the PT8610. This provides 10W output at 2GHz, with 7dB gain and 15% bandwidth. It is a single chip device in a low parasitic package. Companion transistors are the PT8611, at the 5W level, the PT8612, at 2.5W, and the PT8613, at 1W. These devices are designed for use in common-base circuits. MCP Electronics Ltd, Alperton, Wembley, Middlesex, HAO 4PE.

**WW310 for further details**

## Low Phase-distortion Audio Transformers

Gardners Transformers have announced a new standard range of low phase-shift audio transformers capable of handling steep-sided transient signals. The transformers employ toroidal winding and nickel-iron ribbon of extremely high permeability. Phase-shift over the audio-frequency band is less than five degrees

from 20Hz to 20kHz, and frequency response is within 0.5dB from 10Hz to 80kHz (13 octaves). A steep-sided transient signal can be handled without generation of overshoot up to +12dBm at 20Hz and +20dBm at 50Hz. One type in particular, the MU7590, which is designed for 600-Ω line-bridging applications, will handle voltage levels up to +24dBm at 20Hz. The transformers are electrostatically and magnetically shielded, and are assembled in a cylindrical mumetal case 60.5mm in diameter and 71mm high and mounted on an international octal plug-in base. Gardners Transformers Ltd, Christchurch, Hants.

**WW318 for further details**

## 50A Complementary Transistors

Two pairs of complementary silicon power transistors, p-n-p types 2N5683 and 2N5684 and n-p-n types 2N5685 and 2N5686, introduced by Motorola, are each rated at a maximum collector current of 50A. Together with a collector breakdown voltage of 60 to 80V, this high current rating makes the transistors suitable for high-power amplifying applications. Minimum current gains of 15 at 25A and 5 at 50A are exhibited. The devices can also be used in switching circuits such as 1kW inverters and converters, motor controllers and lamp drivers, a maximum collector-to-emitter saturation voltage of only 1V at 25A ensuring low-loss operation in saturated switching circuits. Transition frequency is 2MHz (max.) at 5A. Housed in a TO-3 case, each device dissipates a total of 300W at a case temperature of 25°C. Motorola Semiconductors Ltd, York House, Empire Way, Wembley, Middx.

**WW313 for further details**

## Microphone Amplifier

I.C. type TAA970 from Mullard can be used with piezoelectric and dynamic microphones as an amplifier for telephone circuits. The gain of the amplifier is independent of the polarity of the supply. Typical voltage gain and output impedance is either 180dB and 115Ω or 130dB and 80Ω depending on pin interconnections. The encapsulation is TO-74. Mullard Ltd, Mullard House, Torrington Place, London W.C.1.

**WW 304 for further details**

## High C.M.R. Differential Amplifier

A new differential amplifier type E71, by Computing Techniques, has an input bias current of 10pA, common mode rejection of 100dB and a common mode voltage range of ±10V. It has an overload recovery time of 1μs, slew rate of 2.5V/μs, open loop gain of 10<sup>5</sup> and will drive a 2kΩ load to ±10V from ±15V supplies without limiting. Using silicon

transistors throughout, the E71 is protected against damage by short circuits from output to earth. It is especially suitable for applications requiring an f.e.t. input stage with good common mode performance and fast overload recovery time. Computing Techniques Ltd, Westminster Bank Chambers, Bridge Street, Leatherhead, Surrey.

**WW317 for further details**

## V.H.F. Communications Aerial

An addition to the Panorama range of v.h.f. communications aerials is the FX helical spring which is only one-third the length of a comparable quarter-wave rod. Its flexibility, ruggedness and low profile provide considerable protection against rough handling and accidental breakage,

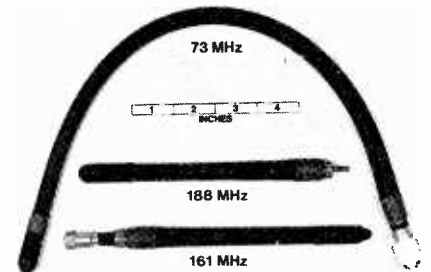

especially when used with portable equipment. Available with 4B.A. end stud as standard or fitted with customer designated connector, the FX aerial is supplied to specified frequencies within the range 70-240MHz. Panorama Radio Co. Ltd, 73 Wadham Road, London S.W.15.

**WW312 for further details**

## Reflex Klystron

English Electric has added a low-voltage, rugged reflex klystron (type K3078) to their range of oscillator klystrons. A direct equivalent to the VA203B/6975, this tube has improved vibration f.m. performance, and will operate under severe environmental conditions. The frequency range is 8.5GHz to 9.6GHz, mechanically tuned by a single screw. Output power (typical) is 35mW. English Electric Valve Co. Ltd, Chelmsford, Essex.

**WW315 for further details**

## Dual-in-line Sockets

A range of 14-pin dual-in-line sockets is now available from EF Electronics, Tovil, Maidstone, Kent. The new socket features a generous lead-in for easy loading and a large central channel for easy removal of i.c.s. The body is glass-filled nylon. Contacts are beryllium or phosphor bronze, both with 1 micron of hard gold over a nickel flash, or phosphor bronze with no finish. Contact resistances are 15mΩ, 25mΩ or 50mΩ maximum according to contact finish and measured after 1000 insertions. Insulation is



$10^3 \text{M}\Omega$  at 500V and capacitance is 2pF maximum measured between any two adjacent contacts. Cost varies from 2s 9d to 6s 0d according to quantity. EF Electronics, Church Road, Tovil, Maidstone, Kent.

**WW314 for further details**

## High Noise-immunity I.Cs

Two t.t.l. integrated circuits announced by Mullard have a noise immunity figure of not less than  $\pm 6\text{V}$ . The integrated circuits, types GRL111 and GRL101 are intended to provide interface connections with a balanced pair cable, the GRL111 acting as the transmitter and the GRL101 as the receiver. They can be used to complete a compatible link between two independent logic systems. Although designed for use with the Mullard FJ family of integrated circuits, they can be used with almost all saturated logic families. Typical propagation delay for GRL111 is 14ns, and 25ns for GRL101. Mullard Ltd, Mullard House, Torrington Place, London W.C.1.

**WW316 for further details**

## High Current Thyristors

Two new series of 10A and 20A silicon controlled rectifiers, for power switching, voltage regulation and control applications, are available from RCA. The 10A s.c.r.s, designated 40737 to 40748, are intended for 120-V line, 240-V line and high voltage operation and are incorporated in metal packages of press fit, stud, or isolated stud design. The 20A s.c.r.s, designated 40749 to 40760 are also available in press fit, stud and isolated package designs.  $V_{\text{drom}}$  (repetitive peak off-state voltage) is 100V, 200V, 400V, and 600V for both series which are available from RCA's distributors: Semicomps Northern Ltd, of Kelso; E.C.S. Ltd, of Windsor; and R.E.L. Equipment and Components Ltd, of Bancroft, Herts.

**WW 303 for further details**

## X-Y Display Oscilloscope

Marconi Instruments have produced an X-Y display monitor with a screen area of  $170 \times 220\text{mm}$ . The unit, TF 2212, complements the existing range of the

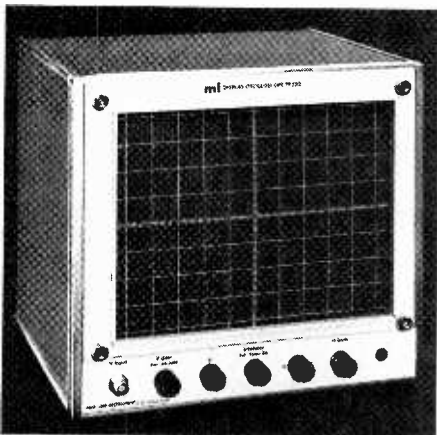

company's sweep generators. Vertical sensitivities are calibrated 5mV/cm and 50mV/cm positions with continuously variable control. The vertical bandwidth is from d.c. to 10kHz. Horizontal sensitivity is 100mV/cm (approx.) with continuously variable control. The horizontal bandwidth is d.c. to 1kHz. Price about £180 in U.K. Marconi Instruments Ltd, St. Albans, Herts.

**WW 302 for further details**

## Power Microcircuits

The PM range of power hybrid microcircuits from WEL is designed for low-cost power control applications. They are particularly suited for stepless speed control of universal motors and variable power supplies. Various combinations of thyristors and/or diodes are encapsulated in epoxy resin mounted on a heat sink with connections made by spade tags. Due to the high thermal conductivity of the heat sink, currents of up to 12A may be handled by the circuits. Three types of circuit are in production: the PM5, a thyristor and diode combination with current load capability up to 12A, for use as a half-wave motor speed control system; PM7, a full-wave rectifier bridge; and PM6, diode pairs. From these two latter types a variety of d.c. power supplies can be produced with outputs up to 9A. They can also be combined to form three-phase bridges, solid state a.c./d.c. switches and high voltage stacks. All three microcircuits are available with a variety of operating voltages—PM5 from 200-800V, PM6 and 7 from 200-1400V. The price of a 5A 400V universal motor controller type PM7, output 9 amps, is 16s 9d (100 pieces). WEL Components Ltd, 5 Loverock Road, Reading, Berks.

**WW 301 for further details**

## Broadband Suppressors

A range of interference suppressors—the Ammonite range—is available from Birch-Stolec. Although designs are possible for cut-off frequencies as low as 2kHz, it is expected, by the manufacturers, that the most frequent applications will be in the 20-100kHz region. The range has a voltage rating up to 250V a.c. 50Hz, rated current of 0.5 to 15A and a cut-off frequency from 5kHz to 50kHz. In the discoidal (grommet) Ammonite, interference energy is converted to heat. Birch-Stolec Ltd, Ponswood Industrial Estate, Windmill Road, Hastings, Sussex.

**WW 307 for further details**

## 8-track Magnetic Recording Head

Multi-track operation in small computers is now made possible, claim Phi Magnetronics, by their new 8/8 magnetic head. Gap scatter is claimed to be better than  $25\mu\text{s}$  at  $7\frac{1}{2}$  i.p.s. Designed for use with quarter-inch tape, the new head, type



DHM/030, has a track width of 0.5mm and track spacing of 0.81mm. Inductance at 1kHz is  $30\text{mH} \pm 20\%$ . Playback full level is  $85\mu\text{V} \pm 1.5\text{dB}$ . Crosstalk from a tape recorded to saturation level on seven tracks, measured on the unrecorded track, is better than  $-20\text{dB}$ . Signal current is  $300\mu\text{A}$  r.m.s. and peak bias 1.7mA at 50kHz. Phi Magnetronics (Sales) Ltd, Penwerris Lane, Falmouth, Cornwall.

**WW 305 for further details**

## M.O.S. Random Access Memory

A low-cost 64-bit semiconductor random access memory constructed with m.o.s. transistors (type MC1170L) has been introduced by Motorola. Access time is 400ns. Organized as 16 words of four-bits each, it uses a four-input binary address and contains full decoding circuitry. An ENABLE input is provided for easy address expansion. Read/write buffer circuits on the output bit lines, which allow as many as 20-bit lines to be "wired ORed", simplify the design of larger memory systems using this unit. Further simplification is afforded by the single-phase clock used by the device. Designed for use in memory systems with access times of less than 500ns, the MC-1170L is intended primarily for small buffer memories but, because the stored data is read nondestructively, it can find application in systems where destructive-readout delay-line memories are used. Motorola Semiconductors Ltd, York House, Empire Way, Wembley, Middx.

**WW 309 for further details**

## F.E.T. Op. Amp

A low-cost f.e.t.-input differential amplifier, the Fairchild Controls ADO-84/10, announced by G.D.S. (Sales) has 50pA maximum initial bias current, 25pA offset current and  $50\mu\text{V}/^\circ\text{C}$  maximum offset drift. Open-loop gain is 100dB with a small-signal bandwidth of 1MHz. Full output bandwidth is 75kHz at  $\pm 10\text{V}$  and  $\pm 5\text{mA}$ , slew rate being  $4\text{V}/\mu\text{s}$ . Full short circuit protection is built in. Both common-mode and differential input impedances are  $10^{12}\Omega$  with 60dB common-mode rejection. The amplifier is suitable for operation over the temperature range  $-25^\circ\text{C}$  to  $+85^\circ\text{C}$  and needs  $\pm 15\text{V}$ , 10mA supply. A mating socket (ASO-2) is also available. Price £7 2s 10d. G.D.S. (Sales) Ltd, Michaelmas House, Salt Hill, Bath Road, Slough, Bucks.

**WW 306 for further details**

# Literature Received

*For further information on any item include the WW number on the reader reply card*

## ACTIVE DEVICES

We have received two pocket books from Newmarket Transistors Ltd, Exning Rd, Newmarket, Suffolk.

Custom hybrid microcircuits ..... WW401  
Products mini portfolio ..... WW402

A frequency-sensitive switch microcircuit type FX101 is described in leaflet D/026 from Consumer Microcircuits Ltd, 142/146 Old St, London, E.C.1. .... WW403

The phase-locked-loop microcircuit type NE560B and NE561B manufactured by Signetics is described in a leaflet from LST Electronic Components Ltd, 7 Coptfold Rd, Brentwood, Essex. .... WW404

National Semiconductor, 2900 Semiconductor Drive, Santa Clara, California 95051, U.S.A., have produced an interesting brochure called "Reliability report—m.o.s. integrated circuits". The data is compiled from 1,479,000 life test device hours ..... WW405

A 36-page publication giving data on the AEG range of thyristors, triacs and diodes may be obtained from Electronic Component Services (Worcester) Ltd, Victoria House, 63-66 Foregate St, Worcester ..... WW406

Over 200 c.r.t. types are covered in the new brochure from Brimar (Thorn Radio Valves and Tubes Ltd, 7 Soho Square, London, W.1.). The brochure is called "Brimar industrial cathode ray tubes" and consists of 30 pages ..... WW407

Application note No.3 from Hivac Ltd, Stonefield Way, Ruislip, Middlesex, discusses a glow diode for photocell switching, describes flash tubes and gives details on calculating the operating conditions of neon lamps ..... WW408

Full circuit diagrams and component lists with relevant constructional information for a complete multi-channel proportional radio control system is given in the publication "A six-channel digital proportional radio control system" which costs 3s 6d from Ferranti Ltd, Gem Mill, Chadderton, Oldham, Lancs.

A new application note from Mullard (TP1149) describes a high input impedance f.e.t. input stage for an operational amplifier. I.E.D., Mullard Ltd, Mullard House, Torrington Place, London, W.C.1. .... WW409

"A novel shaper circuit for d.t.l. and t.t.l. input interfacing" is the title of an application note produced by ITT Semiconductors,

Footscray, Sidcup, Kent ..... WW410

We have received a variety of application notes from RCA Electronic Components, Harrison, New Jersey 07029, U.S.A.

AN4124. "Handling and mounting RCA moulded plastic transistors and thyristors" ..... WW411  
1CAN6218. "Gate-oxide protection circuit in RCA cos/m.o.s. digital integrated circuits" ..... WW412  
AN4242. "A review of thyristor characteristics and applications" ..... WW413  
1CAN6267. "Astable and monostable oscillators using RCA cos/m.o.s. digital integrated circuits" ..... WW414  
AN4277. "Description and application of RAC Numitrons" ..... WW415  
We have also received from RCA their "Receiving Tube manual" (RC27) consisting of 672 pages devoted to entertainment valves and tubes. Price \$2.

Filing Instruction No.16 is available for the AEI Semiconductors Technical Data Handbook. AEI Semiconductors Ltd, Carholme Rd, Lincoln ..... WW416

Ferranti, Gem Mill, Chadderton, Oldham, Lancs, have sent us a good deal of literature on their 7400 series t.t.l. for industrial temperature ranges ..... WW417

"Electronic component selector guide" from Celdis Ltd, 37-39 Loverock Rd, Reading, Berks RG3 1ED, lists a wide range of products, mostly semiconductor, from a large number of manufacturers ..... WW418

## PASSIVE COMPONENTS

Rank-Bush-Murphy have produced their first catalogue of electronic components. The catalogue, which is not a catalogue of replacement parts for R-B-M receivers, lists 1,800 components. Rank-Bush-Murphy Ltd, Drayton Rd, Boreham Wood, Herts .. WW419

The current ITT Electronic Services (Edinburgh Way, Harlow, Essex) stock catalogue has been enlarged to 1168 pages and lists a vast range of electronic components .. WW420

"Advance Data—No.18" from AMP of Great Britain Ltd, Terminal House, Stanmore, Middlesex, is devoted mainly to the "Termin-twist" connection system ..... WW428

We have received the following literature from

F. C. Lane Electronics Ltd, Slinfold Lodge, Horsham, Sussex.

Short-form catalogue (plugs and sockets) ..... WW421  
Rendar price list ..... WW422  
Ether price list ..... WW423

A smart set of cards in a cardboard wallet describes the expanded range of Amphenol min-rac 17 plug and socket connectors. Amphenol Ltd, Thanet Way, Whitstable, Kent ..... WW424

A 26-page catalogue containing details of a variety of switches is available from Carlingswitch Ltd, Victoria Works, Water Lane, Watford, Herts. .... WW425

Heat sinks, racks, printed cards and reed and mercury relays are listed in a catalogue, in French, available from S.E.E.M., 8, rue Boutard, 92-Neuilly, France ..... WW426

West Hyde Developments Ltd, Ryefield Cres., Northwood Hills, Northwood, Middlesex, have produced a range of illuminated push-button switches which are described in a leaflet ..... WW427

## EQUIPMENT

"Dana—A world of measurement capability" is the short-form catalogue of Dana Electronics Ltd, Bilton Way, Dallow Rd, Luton, Beds. It lists a variety of test equipment ..... WW429

The latest short-form catalogue from the Croydon Precision Instrument Company, Hampton Rd, Croydon CR9 2RU, lists ranges of bridges, precision potentiometers, resistance boxes and standards, supply units, voltage ratio boxes, etc ..... WW430

Spectrum analysers, noise and field intensity meters, a.c.-d.c. standards and precision measuring equipment, synco test equipment, voltmeters, frequency meters and generation equipment are featured in the new short-form catalogue from Singer Instrumentation which is available from Roberts Electronics, 17 Hermitage Rd, Hitchin, Herts ..... WW431

"Keithley engineering notes" Vol.18, No.1, describes a d.c. current source (0.005% regulation, 0.02% resolution and 500V capability), a picoampere source ( $10^{-14}$  to  $10^{-4}$ A, accuracy 0.25%) and a unity gain isolating amplifier ( $10^{12}\Omega$  input isolation,  $\pm 0.3\%$  gain linearity). It is available from Keithley Instruments Inc., 28775 Aurora Rd, Cleveland, Ohio 44139, U.S.A. .... WW432

A logic tutor, Computakit-1, is described in a leaflet from Limrose Electronics, Lymm, Cheshire ..... WW433

## GENERAL INFORMATION

A directory of the laboratories approved by the British Calibration Service can be obtained from: The British Calibration Service, Stuart House, 23-25 Soho Square, London, W.1. .... WW434

Anyone interested in joining the British Amateur Electronics Club should send for the latest copy of the B.A.E.C. Newsletter to C. Bogod, "Dickens", 26 Forest Rd, Penarth, Glamorgan.

with

# ADCOLA

## you're on the right wave-length

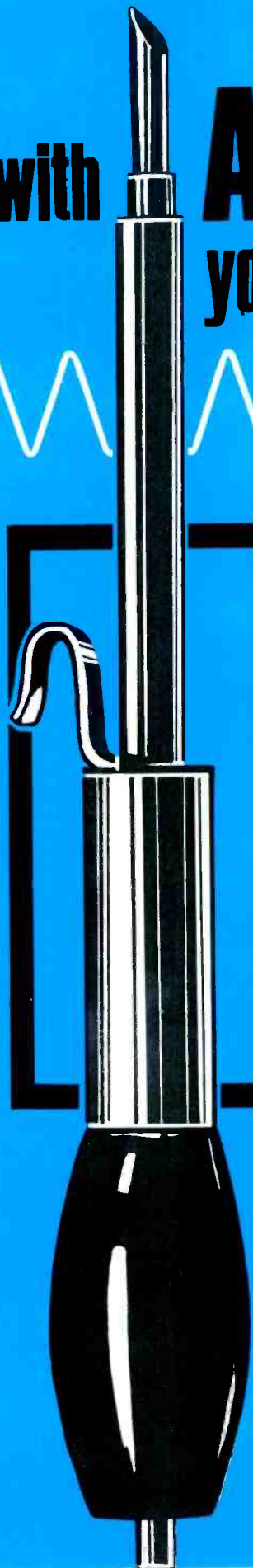

### ADCOLA PRECISION SOLDERING EQUIPMENT

offers you the right quality at the right cost for every requirement from home output to full scale industry.

- Extensive range to choose from.
- Precision quality for increased efficiency.
- Speedy after-sales service.
- Interchangeable bits—ex stock.
- Special temperatures available at no extra cost.
- Designed and developed to lower your production costs.

*Always choose **ADCOLA** for sound soldering!*

# ADCOLA

Registered Trade Mark

**ADCOLA PRODUCTS LTD.**

Adcola House, Gauden Rd. London S.W.4

Tel: 01-622 0291/3

Telegrams: Soljoint, London Telex.

Telex: Adcola London 21851

**POST COUPON NOW FOR DETAILS OF OUR EXTENSIVE RANGE**

To ADCOLA PRODUCTS LTD. (Dept. H), Adcola House, Gauden Road, London, S.W.4.

*Please send me a copy of your latest catalogue by return.*

NAME.....

ADDRESS .....

W.W.1

# HIGH



# & LOW

MELTING POINT SOLDERS FOR SOLDERING

- Gold plated surfaces
- Flexible printed circuits
- Silver plated surfaces
- High working temperature components

## H.M.P.

### HIGH MELTING POINT

For service at high temperature, or service at very low temperatures. Outstanding creep strength. Melting range 296°C - 301°C (565°F - 574°F).

#### Applications

A useful application of H.M.P. is the soldering of joints close to each other in such a way that the connections made first are not re-melted while later joints are made, with for example, a standard 60/40 alloy, melting point 188°C. Essential for use where high operating temperatures are experienced, for instance, electrical motors, car radiators, high temperature lamps. H.M.P. is also ideal for equipment, which is being operated in low temperatures, as it reduces the chance of the joint becoming brittle.

#### Specification

Multicore H.M.P. alloy complies with BS.219 Grade 5S. Supplied in a form of Ersin Multicore 5 core solder wire on 1lb. or 7lb. reels, incorporating Ersin 362 rosin based flux. This non-corrosive flux-cored solder wire complies with BS.441 and is available from 10 to 26 s.w.g., and in Multicore Solder Preforms. Ask for Technical Bulletin No. 1369.

## L.M.P.

### LOW MELTING POINT

A low melting point solder for soldering silver plated and gold plated surfaces. Melting point 179°C (354°F).

#### Applications

L.M.P. reduces the absorption of silver or gold into the solder alloy whilst soldering, and therefore, preserving the silver or gold plated surfaces. Also reduces the chance of a brittle joint being made.

#### NOTE

a) The solution of gold into tin rises rapidly with temperature and so the use of L.M.P. Low Melting Point Solder is preferable.

b) The solution rate of gold into tin is also reduced because L.M.P. is a ternary alloy comprising tin, lead and silver.

#### Specifications

L.M.P. is normally supplied in the form of Ersin Multicore 5 core solder wire, incorporating Ersin 362 rosin based flux, which complies with Min. Tech. specification D.T.D. 599A. It is available from 10 to 34 s.w.g. in 1lb. or 7lb. reels and Multicore Solder Preforms. Ask for Technical Bulletin 1469.

## T.L.C.

### EXTRA LOW MELTING POINT

Extra low melting point solder. Melting point 145°C (293°F).

#### Applications

T.L.C. alloy can be used whenever a soldered joint should be made with the minimum heat input. This would include heat sensitive transistors, flexible printed circuits and gold plated surfaces. The melting point of T.L.C. alloy is 38°C lower than any tin/lead alloy. Because of its low temperature application it is considered completely non-toxic in use unlike the high temperature cadmium-bearing brazing alloys.

#### Specification

T.L.C. alloy is normally supplied in the form of Ersin Multicore 5 core solder wire, incorporating Ersin 362 rosin based flux, which complies with Min. Tech. Specification D.T.D. 599A. T.L.C. alloy can also be supplied in the form of Multicore precision made solid solder wire, Extrusol extruded solid solder bars for solderbaths and Multicore Solder Preforms. Available from 10 to 34 s.w.g. on 1lb. or 7lb. reels. Ask for Technical Bulletin No. 1569.



Please write for technical information on your company's notepaper.

MULTICORE SOLDERS LTD.  
HEMEL HEMPSTEAD, HERTS.  
PHONE: HEMEL HEMPSTEAD 3636 TELEX: 82363



WW-003 FOR FURTHER DETAILS