

# wireless world

MAY 1977 40p

**Electrolytic capacitor tester**  
**Radio in the '80s**

**New isotope  
scanning  
technique**

Australia \$A1.20  
Canada \$1.50  
Denmark Kr. 5.00  
Finland Fmk. 6.50  
Germany DM. 4.50  
Greece Dr. 45.00  
Holland Dfl. 4.50  
Italy L. 900  
Malaysia M\$3.25  
New Zealand \$NS1.40  
Norway Kr. 10.00 incl. moms  
Portugal Esc. 40.00  
South Africa R. 1.10  
Spain Ptas. 80.00  
Sweden Kr. 6.90 incl. moms  
U.S.A. \$1.50

BBC EXCLUSIVE  
Quad Decoding Part 1  
Variomatrix Adapter





**NEW**

# Automatic fm/am Modulation Meter

How long does it take for you to make a series of modulation tests with the meter you are using? The M.I. TF 2304 Automatic Modulation Meter eliminates at least five manual operations for each test and even more per test when a series of measurements is to be made. That can save you hours in a production day.

When connected to a transmitter, the TF 2304 automatically tunes to the carrier frequency and automatically sets the level, all within a few seconds. Exceptionally efficient screening and a very low distortion mixer ensure locking to the wanted signal. It is only necessary to select the required mode and range and the meter will read either deviation or % depth. L.E.D. lamps indicate if the signal level is too high or low and a push-button inserts a 20 dB attenuator to extend the maximum input level to 1 watt.

The basic frequency range is 25-1000 MHz and there are 8 peak deviation ranges covering 1.5 kHz f.s.d. to 150 kHz f.s.d. and a.m. depth ranges of 30% and 100% f.s.d. all with a modulation frequency range of 50 Hz to 9 kHz. Modulation symmetry can be checked by push-button selection of positive or negative deviation and peak or trough amplitude.

The accuracy of modulation measurement is  $\pm 3\%$  of full scale so transmitter deviation can now be set close to the permitted maximum with a consequent increase in efficiency.

The TF 2304 can be operated either from mains or internal rechargeable battery. It's small and light and there's a comprehensive range of accessories including a carrying case.

The price will pleasantly surprise you. Ask for full details.

**mi: THE AUTOMATIC CHOICE**

MARCONI INSTRUMENTS LIMITED,

Longacres, St. Albans, Hertfordshire, AL4 0JN. England. Telephone: St. Albans 59292. Telex: 23350.

A GEC-Marconi Electronics Company.  
**WW-001 FOR FURTHER DETAILS**

# wireless world

**Electronics, Television, Radio, Audio**

MAY 1977

Vol 83

No 1497

## Contents

- 35 **Surround sound — time to consolidate**  
36 **Radio in the '80s** by *Duncan MacEwan*  
41 **BBC Matrix H** by *P. A. Ratcliffe and D. J. Meares*  
46 **World of amateur radio**  
47 **Automatic electrolytic tester** by *A. Drummond-Murray*  
50 **Variomatrix adapter for System 45J and Matrix H**  
by *Michael A Gerzon*  
51 **H.F. predictions**  
52 **Logic design — 4** by *B. Holdsworth and D. Zissos*  
55 **Viewdata — 4** by *S. Fedida*  
60 **Letters to the editor**  
Mobile radio planning  
Do-it-yourself biofeedback  
Audibility of phase effects  
63 **News of the month**  
Annan and technology  
ITU Conference results  
British Rail high-speed track measurements  
67 **Two-stage linear amplifier** by *Helge Gronberg*  
71 **Power semiconductors — 2** by *Mike Sagin*  
79 **Circuit ideas**  
Linear voltage/frequency converter  
Pulse-counting frequency comparator  
Op-amp power output stage  
82 **New tomography machine** by *John Dwyer*  
85 **New products**  
**APPOINTMENTS VACANT**  
**INDEX TO ADVERTISERS**

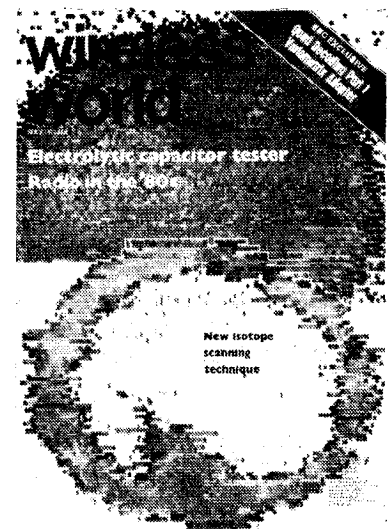

Front cover is a print produced by the Tomoscanner, described by John Dwyer on page 82 of this issue. Print supplied by J. & P. Engineering (Reading) Ltd.

## IN OUR NEXT ISSUE

**Loudspeakers and rooms.** A discussion by James Moir of the interaction between the output of a loudspeaker and the acoustic performance of the listening room.

**Matrix H decoding.** Circuit details of a matrix H variable matrix decoder, a development of Sansui's Variomatrix, for use with experimental surround-sound programmes.

**Using a microprocessor.** The start of a series of articles on the design of a typical processor-based control system, starting with no assumptions of prior knowledge on the reader's part.

ISSN 0043 6062

Current issue price 40p, back issues (if available) 50p, at Retail and Trade Counter, Paris Garden, London SE1. By post, current issue 55p, back issues (if available) 50p, order and payment to Room 11, Dorset House, London SE1 9LU.

Editorial & Advertising offices: Dorset House, Stamford Street, London SE1 9LU.

Telephones: Editorial 01-261 8620; Advertising 01-261 8339.

Telegrams/Telex, Wiworld Bisnespres 25137 BISPRS G. Cables, "Ethaworld, London SE1.

Subscription rates: 1 year: £7.00 UK and overseas (\$18.20 USA and Canada). Student rate: 1 year, £3.50 UK and overseas (\$9.10 USA and Canada).

Distribution: 40 Bowling Green Lane, London EC1R 0NE. Telephone 01-837 3636.

Subscriptions: Oakfield House, Perrymount Rd, Haywards Heath, Sussex RH16 3DH. Telephone 0444 59188. Subscribers are requested to notify a change of address. © I.P.C. Business Press Ltd, 1977

"USA mailing agents: Expeditors of the Printed Word Ltd., 527 Madison Avenue, Suite 1217, New York, NY 10022. 2nd-class postage paid at New York.

**ibpa**  
International Business  
Press Associates

**ABC**  
ASSOCIATION OF  
BUSINESS OF THE GREAT  
BRITAIN & IRELAND

# QUAD-Quarter of a century of amplifier development



The Acoustical Manufacturing Co. Ltd. have been designing and producing amplifiers since 1936 but it was not until 1951 that the Q.U.A.D. 1 was introduced, the forerunner of the Quad series of Amplifiers which have earned an unrivalled reputation for originality of design, excellence of performance and reliability in the ensuing twenty-five years.

The introduction of the Quad 405 current dumping amplifier represents yet another contribution to the science of sound reproduction.

Current dumping successfully overcomes many of the problems associated with high power amplifiers, crossover, thermal tracking and matching of components, added to which the complete absence of adjustments or alignment requirements, ensures that performance will be consistently maintained.

For further details on current dumping and other Quad products write to Dept. WW

The Acoustical Manufacturing Co. Ltd.  
Huntingdon, Cambs., PE18 7DB  
Telephone: (0480) 52561

**Design Council  
Award 1976**

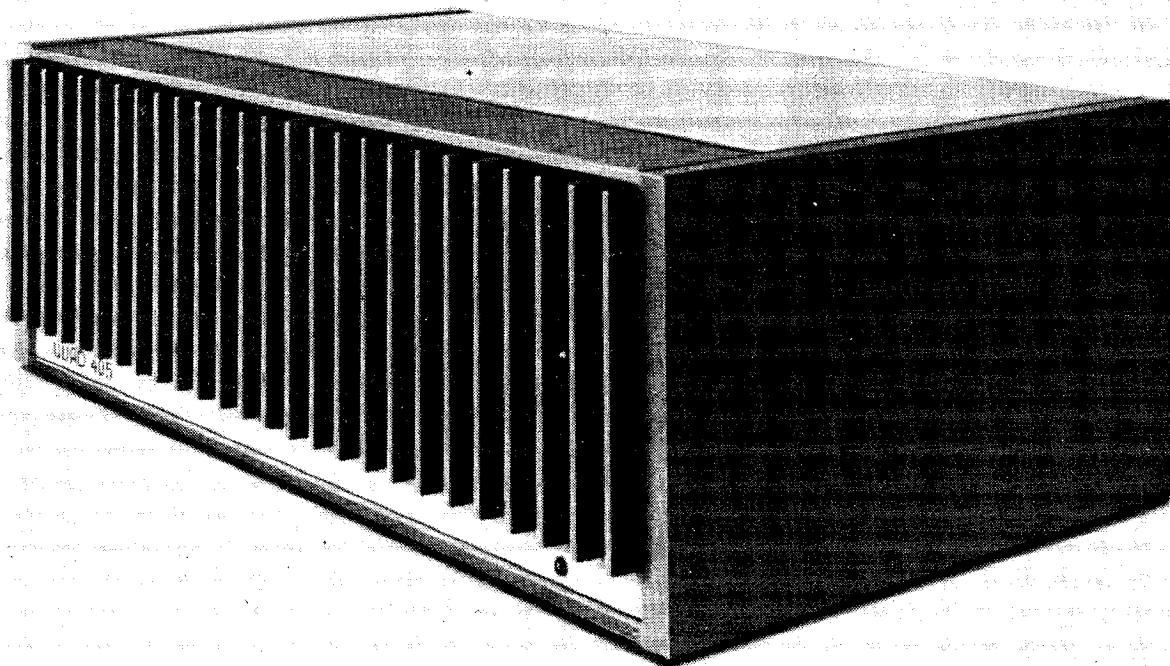

## QUAD

**for the closest approach to the original sound  
for twenty-five years.**

*QUAD is a Registered Trade Mark*  
WW-064 FOR FURTHER DETAILS

# wireless world

**Editor:**  
TOM IVALL, M.I.E.R.E.

**Deputy Editor:**  
PHILIP DARRINGTON  
Phone 01-261 8435

**Technical Editor:**  
GEOFFREY SHORTER, B.Sc.  
Phone 01-261 8443

**Assistant Editors:**  
MIKE SAGIN  
Phone 01-261 8429  
RAY ASHMORE, B.Sc., G8KYY  
Phone 01-261 8043  
JOHN DWYER  
Phone 01-261 8620

**Production:**  
D. R. BRAY

**Advertisement Controller:**  
G. BENTON ROWELL

**Advertisements:**  
PHILIP NOSSEL (Manager)  
Phone 01-261 8622

LEO KEMBERY  
Phone 01-261 8515

CHRIS PRIER  
Phone 01-261 8037

**Classified Manager**  
BRIAN DURRANT  
Phone 01-261 8508 or 01-261 8423

EDDIE FARRELL (Classified Advertisements)  
Phone 01-261 8508

JOHN GIBBON (Make-up and copy)  
Phone 01-261 8353

**Publishing Director:**  
GORDON HENDERSON

## Surround sound — time to consolidate

It may seem strange that when surround-sound equipment sales are at a low level, the systems confrontation is still unsettled, and people apparently are disillusioned by the whole thing, interest in surround sound seems as high as ever among broadcasters, particularly in Europe. This apparent paradox is the consequence of having forced quadrasonics on the public, discovering what went wrong (*Wireless World*, December 1974) and trying to put it right second time round. *Wireless World* is in the midst of publishing details of what may be the most significant contributions to the art, reflecting an escape from the blind alley into which quadrasonics, as conceived at the turn of the decade, appears to have led.

One of the effects of these early attempts at coding two channels for surround use was to send people away thinking of other ways of doing it. One such avenue, followed independently by Duane Cooper and Peter Fellgett, in 1971, led to the omni-phaser idea. This phase-encoding of direction could, by simple sum and difference matrixing, produce a reasonably compatible stereo pair of signals. The snag was a 90° phase difference between the pair.

A derivative of this was therefore studied by the BBC Research Department in 1973. Dubbed Matrix H, it was last in a list of eight arrangements tested. The front part of its pan-locus was bent toward the in-phase mono point on the energy sphere, which gave a front centre sound a reduced phase difference of 48° and appeared to give commendable overall compatibility.

Then in 1975 an effort was made to achieve a compromise, between the limit of RM on the one hand and BMX on the other, that would suit both broadcasters and the record industry. But the move failed (see *News* page 65) and messrs Fellgett and Gerzon were left to put forward their idea for a provisional

industry standard in *Electronics Letters* later that year.

Now that patents have been granted, fuller details of this NRDC-sponsored work are available. They show that a range of options exists for pairwise mixed material to enable a variety of needs to be met; indeed the H matrix could almost be one of the options.

For a surround encoding to be universally adopted, allowance must be made for the addition of a third channel where feasible (a fourth would allow three-dimensional sound reproduction but that seems very much in the future), the resulting system not then needing "rescue" by non-linear circuitry.

The record industry seems well able to produce band-limited carrier-channel discs, but the transmission of quadrature sidebands along with the in-phase difference-signal sidebands can have undesirable effects in some stereo receivers. To prevent this one could transmit the quadrature information at a level chosen to reduce these effects to agreed proportions, hopefully negligible. And to avoid signal-to-noise ratio problems it follows that the bandwidth of this third channel would need to be restricted. Design procedures are now available that allow computation of third signal coefficients so that reduction of its level does not upset localization.

What we now have is the opportunity to standardize on a rational, unified surround sound technology, which will meet the needs of broadcasters and the record industry, now and for the foreseeable future, with an assurance that the system is not likely to be bettered. As these two British proposals — BBC H and NRDC J — have much in common, it would be most unfortunate if this opportunity were to be wasted. We urge the two parties to get together: there is so much to be lost by fighting and so much to be gained by pulling together.

# Radio in the '80s

## Broadcasting and the ideal sound receiver of the future

by Duncan MacEwan, *Chief Engineer, Radio Broadcasting, BBC*

A number of policy changes and trends in broadcasting over the last two decades have a very definite bearing on reception difficulties and the adequacy or otherwise of present day receivers:

● There has been a move away from mixed programming on networks towards channels and stations which can be clearly identified with one particular kind of output, e.g. news, orchestral music, light middle-of-the-road music, rock, country and western, "pop", etc. This "generic broadcasting" concept applies to a greater or lesser extent in many countries of the world today. The BBC itself has for its own national networks such a format (as indicated in Fig. 1).

● Within these basic frameworks, however, most countries run networks which also offer strands or segments of specialised programming, e.g. education, ethnic languages, sport, motoring information, immigrants' programmes, etc. Fig. 2 shows something of BBC Radio's special programme services within its four networks, which it can be seen offer seven different programme outlets. Such widening of choice to the listener must be matched by his ability to take advantage of this by means of a receiver with adequate facilities.

● Programme scheduling on networks has become much more closely geared to the realities of life in the '70s. For example, television competition, not only from outside but also from within the same organisation, is recognised by radio programme planners. Peak listening times — breakfast, middle of the day and early evening — are established and programme patterns developed against such a background. In the process, some of radio's inherent advantages — speed, range of outlets, fulfilling needs which television cannot — can be capitalised on. As a second example, different programming is scheduled during clearly identifiable leisure times, which are the weekends and weekday evenings for most. Furthermore, listening habits have changed dramatically. The television set now occupies the place in the room previously held by the mains radio of the '40s and early '50s, and by far the largest amount of listening is

now done on portables, but with a growing element in cars.

● The introduction of more radio services, many of which have found their outlets on f.m. However, in some parts of the world, for a variety of reasons, countries have grown to rely heavily not just on a.m. in the medium wave-

band but also on long waves. This gives rise to the need for a three-waveband set, even before any short-wave requirement is taken into account for those who either actually need such a facility in order to receive their own national services, or simply wish it in order to extend the range of choice by being able

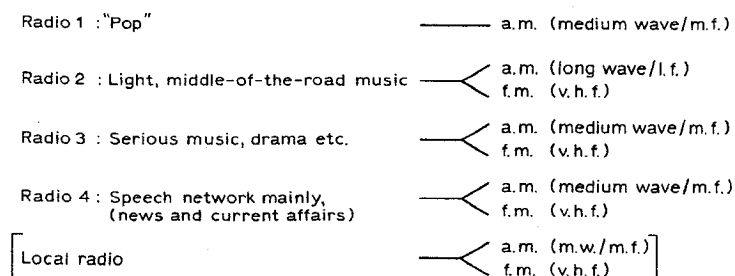

Fig. 1. The basic "generic network" concept used by BBC Radio. Note that there is a total of nine outlets.

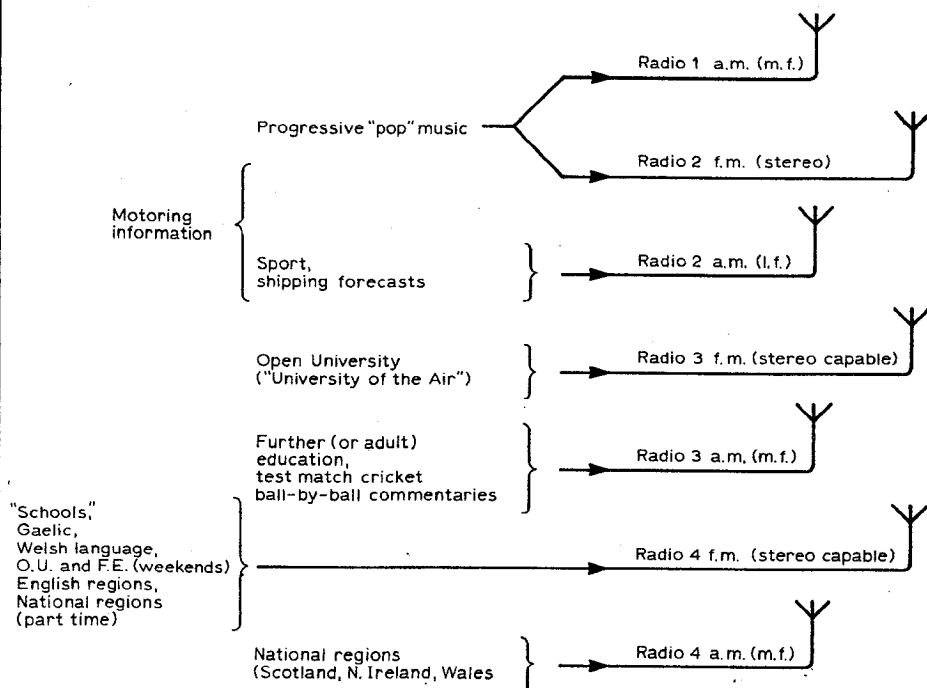

Fig. 2. Examples of specialist programming on BBC Radio's seven network outlets. Note that radio sets must have three wavebands, m.f., l.f. and v.h.f.



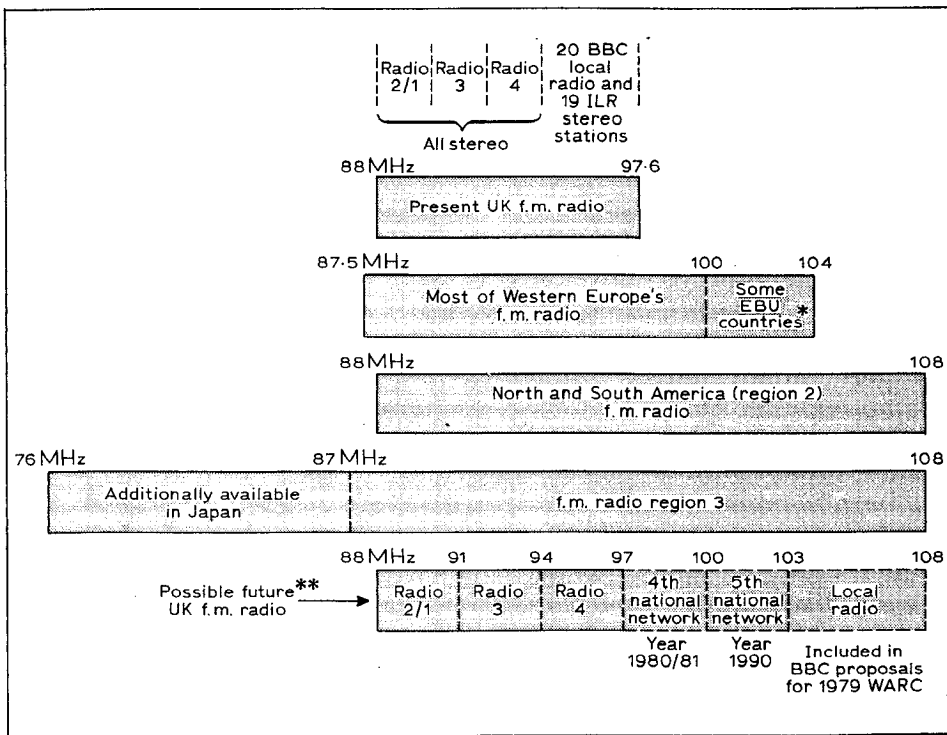

Fig. 3. Band II (v.h.f.) allocation for broadcasting. Notes: \* applies to Austria, Belgium, Denmark, Israel, Italy, Netherlands, Spain, Switzerland, W. Germany and Yugoslavia. \*\* All frequency spacings suitable for stereo transmissions.

is also a function of which end of the a.m. medium wave band the station lies. At the high frequency end, due allowance has to be made for the increased attenuation which is experienced as the signal traverses a city.

While the position in respect of f.m. (Band II v.h.f.) is a good deal easier, the packing density of stations is getting dangerously high in some countries. Stereo channels, which are on the increase, call for more spectrum space than monophonic services. In Band II, frequency allocation is fast becoming very difficult and pressure is being put on other users — taxi, fire authorities, police and ambulance services — to move out of it. In the UK the degree of privation (Fig. 3) is such as to have inhibited the development of further national networks, while extension in the number of local services is in jeopardy. The same is true in certain other countries including those which are restricted by their geographical proximity to the densely populated areas of their neighbours. It is hardly surprising, therefore, that most European countries seek an enlargement of that part of Band II allocated to them as broadcasters. The Americas and the countries in the Far East are in a privileged position with at least 20MHz of band space within which frequencies may be allocated, whereas in the UK it is only 9.6MHz at present.

Many f.m. services were planned in the early '50s in an era when practically all receivers were mains operated and used in fixed positions. Coverage areas were predicted on the basis of roof top (or loft) aerials at a height of 10 metres. The advent of the battery operated transistor set changed all this, and small portables with a built-in aerial and often with only one a.m. band became the norm; many are still in use. Those sets capable of receiving the f.m. services were provided additionally with an extendable rod aerial and used at a height rarely exceeding one metre above ground level. For satisfactory reception at this level, the signal strength required at roof level would have to be four times the strength normally needed for a roof-top aerial. To give point to this, the BBC has quoted for some years, and quite correctly so, its f.m. monophonic service national coverage figure as 99.3% of the population for all three v.h.f. networks, the figure applicable to the roof-top aerial situation. More recently it has estimated, however, that reception on transistor portables of all types is nominally unsatisfactory possibly for as much as 10% of the population. Even with a roof-top aerial good stereo reception calls typically for about twice the signal strength adequate for the same standard of mono, but in difficult reception conditions much more may be needed. Put another way, this means that stereo service areas are always smaller than the monophonic ones.

to listen to broadcasts from distant countries. Whereas in a modern television set channel selection is normally effected by simple switches or buttons, the counterpart of these in the radio set is usually required to band change, leaving station selections to be subsequently achieved by a second process, manual tuning; this in itself is not always found easy, nor can stations invariably be located and identified positively. The problem for the listener in the UK may be highlighted by brief reference to the situation now obtaining in certain cities. In both London and Birmingham, for example, a total of 13 radio broadcasting outlets is available, viz. the BBC's nine plus the a.m./f.m. pairs of two independent commercial local radio stations.

Many broadcasting organisations' programme journals usually have to give pride of place to television programmes and indeed are encouraged to do so in light of the lucrative advertisements they attract. This often results in too little space being left for a proper, easily readable display of radio's multifarious choices. The would-be listeners find difficulty in spotting programmes of their taste and perhaps miss many they might otherwise have enjoyed.

**Technical factors**

The demand for the increased number and range of services has given rise to severe congestion in the a.m. medium and long wave bands. The Geneva fre-

quency conference of 1974-75 authorised transmission for some 10,000 stations in Regions 1 and 3, within spectrum space which allows for a total of only 135 channels (120 medium wave and 15 long wave). This represents an increase of 2½ times the present number of assignments with a total carrier power of 540 megawatts — a greater than four-fold increase. Services after dark will inevitably suffer badly and greater reliance must therefore be placed on f.m. in the future. Broadcasting organisations may well find themselves having to work out a strategy for weaning listeners off a.m. where such outlets are merely carrying in duplication the same programmes. "On air" and written publicity would be key factors in any campaign of this kind.

Because of the different propagation characteristics prevailing during the hours of darkness, which give rise to the all too familiar night-time interference, population coverage figures are lower at these times. For example, in the BBC's own case:

|         | Daylight | Night-time |
|---------|----------|------------|
| Radio 1 | 87%      | 37%        |
| Radio 2 | 98%      | 83%        |
| Radio 3 | 94%      | 72%        |
| Radio 4 | 98%      | 74%        |

In the face of these night-time figures alone, a case can be made for duplication on f.m.

Many of the world's a.m. services were planned on the basis of much lower signal strengths than are now found necessary in city centres, with their high rise, steel framed buildings. In an earlier era the BBC considered 3 to 5 millivolts per metre to be adequate, whereas now it recognises the need for about 10 millivolts. In certain other countries signal levels as high as 25 millivolts are considered essential. This

A recent BBC Engineering/Audience

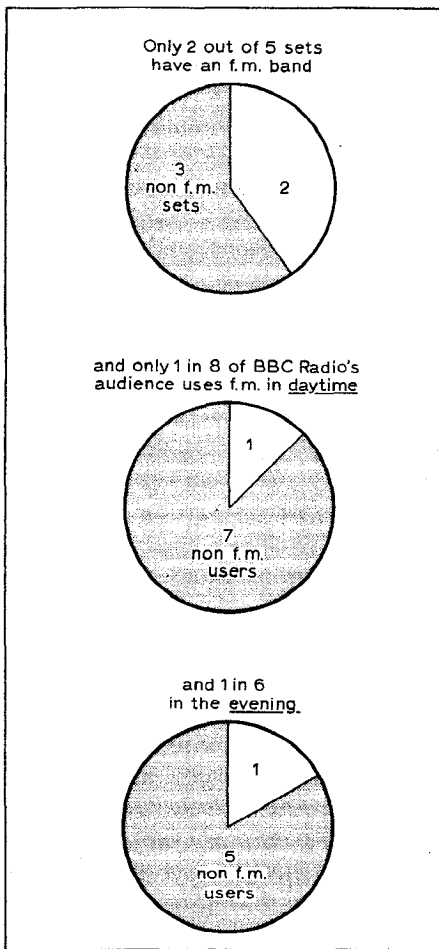

Fig. 4. Radio set statistics in the UK.

Research survey in some depth has demonstrated the continuing importance to BBC radio of its a.m. services. Over 86% of all listening is done on the medium and long wavebands and 58% on portable receivers. This latter figure indicates very clearly that there are almost equal markets for both the good quality fixed-position mains receiver and the portable. Listening in cars (6.5%) was established as of growing importance.

The survey has also shown that even now, 20 years after the BBC's first v.h.f./f.m. transmitter went on the air, only 40% of the sets in the hands of the British public have facilities for receiving such transmissions. F.m. receivers, in spite of affording vastly improved quality, remain in many cases more difficult to tune, and the portables are equipped with awkward rod aerials, consume more battery power and have to be carefully placed within the room for optimum results. Since they also invariably cost more, customer and listener resistance is generated. Furthermore many v.h.f. portables have too small loudspeakers to take much advantage of the higher quality offered by the transmitted signals. Under these circumstances it is more difficult to convince the public that the f.m. service is so very much better than the a.m. one. In addition, good f.m. car radios tend to be very costly, and suppression of ignition, wiper and other local electrical interferences proves difficult. Since this

varies from model to model and is often a function of the car manufacturing process, no one solution can be universally applied, which means that installation costs tend to be high. Too few good economically priced f.m./a.m. car radios are available; even fewer have built-in suppression and cover all three wavebands.

In other parts of the world the position may well be different.

Most broadcasting organisations, when establishing their f.m. services some time ago, did so with a horizontal plane of polarisation. How well does this serve the listener to a portable set with its vertical rod aerial in and out of doors, and those in cars? A recent EBU Working Party K study showed under what circumstances horizontal, vertical or mixed polarisation gave optimum results. For this particular type of potential audience it concluded that in other than rugged terrain served by an existing horizontally polarised transmitter it would be advantageous to change to or establish from the outset either mixed or vertical polarisation. (Many transmitting stations in the USA have been modified in this way during the last decade.) The cost of such a programme of work for a national broadcasting organisation is, however, prodigious. Of the BBC's own 20 local radio stations built during the 1970-72 period, seven are slant polarised as a result of the same kind of considerations, coupled with the need to keep faith with those f.m. listeners who had equipped themselves in earlier years with horizontal roof-top aerials for the three national network services and for

whom a move to vertical polarisation would have meant too severe a drop in signal strength.

In the duplicated service situation, considerable problems can arise in those parts of a country where the a.m. and f.m. transmitter coverages differ, leaving a proportion of the listeners solely dependent on one or other outlet. In the UK this difficulty is prevalent in mountainous regions of Wales and in parts of the north and north west of Scotland. For two principal reasons — finance and frequency allocation — such situations can present nearly insoluble problems, and are most acute for a public service broadcasting organisation which has as its objective 100% national coverage.

The language of both the broadcasting engineer and set manufacturer often act against the public's interest and certainly its understanding of wavebands and frequencies — there is much talk of a.m. and f.m., medium wave, long wave and v.h.f., m.f. and l.f., of metres, kilohertz and megahertz. On the European continent many countries adopt the simple expedient of quoting channel numbers only, where the f.m. band is concerned, while some manufacturers continue to put station names on their

Fig. 5. Features of the ideal set of the future. In addition to those listed it should have an internal aerial, built-in recorder, rechargeable batteries and an integral charger, interference protection, and a sealed rigid and waterproof cabinet with improved acoustics.

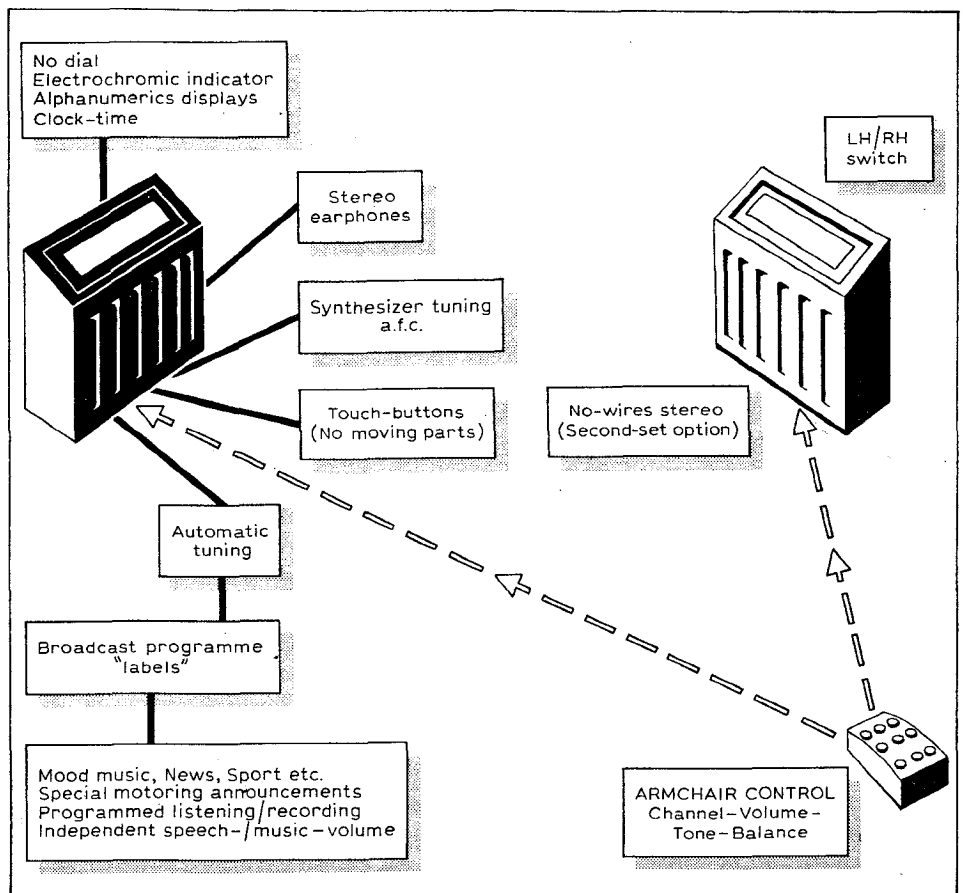



set dials — a restriction for the broadcaster in the face of any impending reallocation of frequencies and a potential source of frustration to the listener.

### Requirements for sets

The conclusions which might be drawn from all this are that if in the future the broadcaster is not to be restricted and the listener suffer deprivation:

- every set sold in the country must be capable of receiving at least all the indigenous services available in that country. This must be made to apply to both home produced and imported sets, and legislation will be required to ensure the inclusion of all the necessary wavebands
- f.m. portables must be made easier to tune and be rid of the rod aerial
- an adequate number of pre-set push buttons should be provided for making network or station selection and switching as simple as it already is on television sets
- channel identification must be simplified
- programme journals need designing with the problems outlined earlier very much in mind
- the frequency with which stations are identified "on the air" needs to be increased in subtle ways
- signal strengths will in some cases have to be increased to take greater account of the indoor listener using his portable in one room or another, and often within a steel framed building
- changes need to be made in the plane of polarisation of many f.m. transmitters
- f.m. portables could with advantage be made more sensitive to help the "fringe area" listener.

The immediate problem is one of ensuring that the right programmes can be easily found and listened to around the home in a variety of domestic situations, in the car or out of doors. Potential audiences will be lost and programmes missed unless these can be easily and positively located. The complex programming of a multiplicity of transmission outlets can only be really successful if programme people as well as engineers understand the technical parameters of the problem and jointly engage with the receiver industry in seeking a solution.

### The ideal set of the future?

Looking forward into the 1980s, the ideal radio set might well have the following features:

No dial but either an alphanumeric

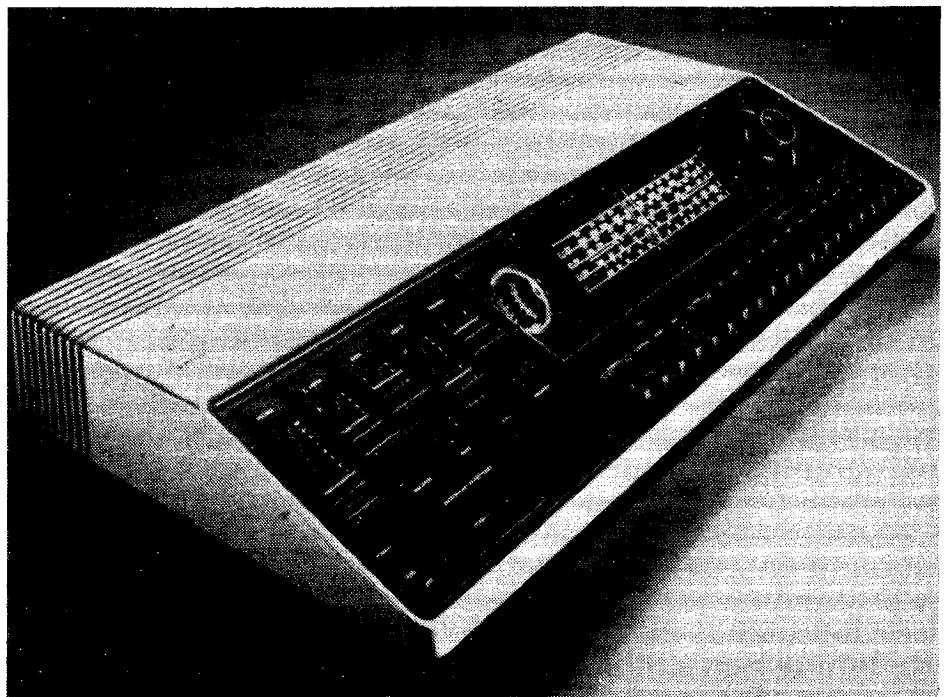

Fig. 6. Receiver with "electronic search tuning" operating on the f.m. band (Phillips type RH752).

display or an electrochromic indicator. The frequency or channel identification could simply appear as a number in a "window". Some of the more sophisticated tuner-amplifier combinations at the expensive end of the market already use an alphanumeric display of which Toshiba, Revox and Telefunken are examples. Electrochromic cells which might well prove suitable for this purpose have been developed by ICI.

**No manual tuning control** as such, the set using pre-tuned button selection, or this combined with "memorised selection". A new Swiss Revox tuner has a programmable memory — 16 pre-sets with a storage time of 6 months before any re-establishing of the choices originally made becomes necessary. Philips are marketing a receiver with "electronic search tuning" — by pressing a button the tuner will search up or down the band, stopping for 2 seconds on any f.m. signal of sufficient strength before moving on to the next one. When the listener is satisfied with what he hears he simply releases the button. This particular tuner also includes a "fast run-on" or "back" facility (Fig. 6). Blaupunkt have had a car radio on the market for some years with "search" mode.

**Plug-in pre-set frequency cards** for the channels applicable to the area in which the set is to be used; these could be issued with the local area's edition of the programme journal and would ensure that the receiver was tuned to the correct station. (A decision at the Geneva l.f./m.f. conference that the a.m. m.f. broadcast carrier frequencies be multiples of 9kHz greatly assists concepts like those above.)

**Electronic programme "labelling"** by the broadcaster, using unobtrusive data

signals travelling with the broadcast signal signifying, for example, a particular channel or type of programme. Various technical possibilities suggest themselves using a sub-carrier in or out of band. Frequency modulation of the a.m. carrier is another avenue of approach. Many applications for such labels are possible:

- Programmes could be selected by type or channel and a receiver designed to "search" the frequency band for a programme carrying a particular label; generic broadcasting makes such a concept more meaningful for the listener. Since searching may take time, it is possible to envisage a second, auxiliary receiver contained within the same box that would search and log behind the scenes, as it were, so that programmes or stations would be available for the listener without delay.
- A receiver could be pre-programmed for an evening's listening, making use of broadcast data labels to switch "on" and "off", channel select, etc, according to a pre-set plan.
- Coupled with a built-in recorder and using similar methods to that above, selected programmes (e.g. news bulletins, weather forecasts, educational programmes, etc) could be stored for later recall by the set owner.
- Such a receiver could incorporate a digital clock either driven from an internal quartz oscillator or "running free" but corrected at regular intervals by clock-time data signals transmitted by the broadcaster, thus absolving the listener from the need to take any action himself.
- Remote control by the broadcaster of

Fig. 7. Set which automatically watches for "programme-labelled" news broadcasts from Radio Luxembourg and becomes audible when one is being transmitted (ITT "Oceanic").

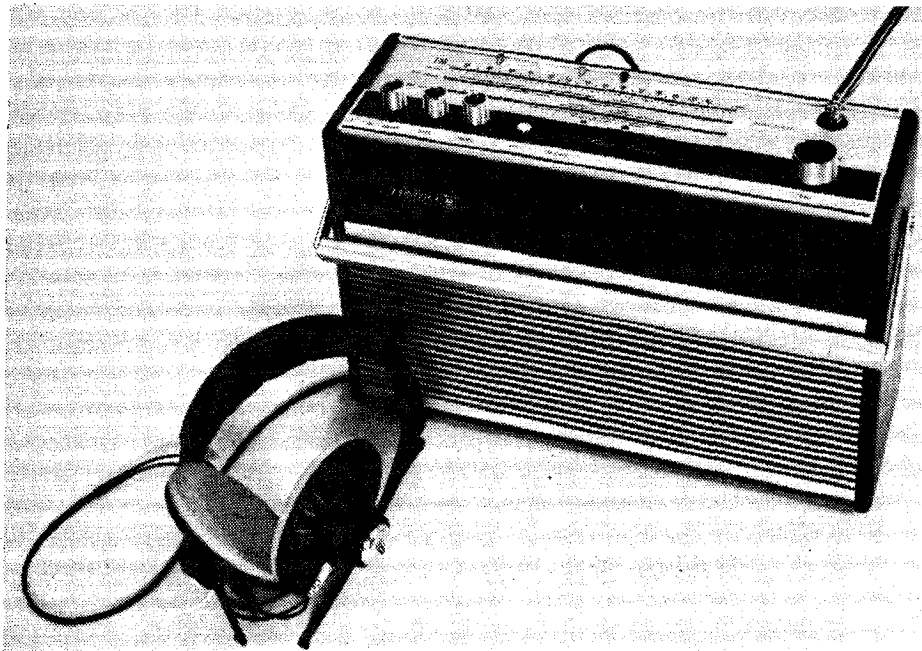
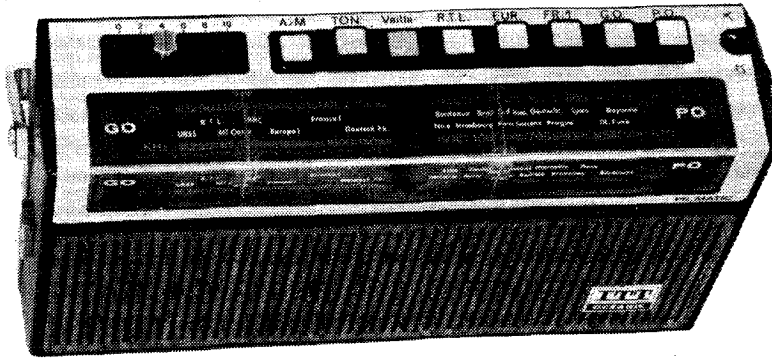

Fig. 9. Portable with stereo decoder for earphone listening (Hacker "Silver Knight").

the volume required for satisfactory speech and music levels by 'data-labelling', which would solve an age-old listeners' complaint.

Radio Luxembourg uses a simple form of programme-labelling by adding coded signals just before and after its news broadcasts. A frequency within the audio band (2325Hz) carries frequency modulation in the shape of a square wave; a deviation of 175Hz is used to open the receiver and 75Hz to close it. ITT market the "Oceanic" receiver (Fig. 7) with a fixed tuning button for RTL associated with which is another marked "VEILLE"; with both pressed the receiver "watches" for news broadcasts only, and bursts into audio life when one is being transmitted. The Dutch are also beginning to experiment with coded programme-labelling using a sub-carrier well out of the audio and stereo bands.

The American SCA (Subsidiary Communications Authorisation) or "store-casting" facility as it is commonly

called. This could be used for an additional low quality monophonic service of narrow bandwidth when the main transmission was also monophonic.

An f.m. as well as a.m. ferrite aerial contained within the body of the set. The BBC's Research Department has modified a portable in this way and has also produced two different versions for cars, all with encouraging results (Fig. 8).

**Armchair control** of channel, volume, tone and stereo balance using remote acoustic, infra-red, etc. control.

**Improved f.m. interference protection** drawing upon new techniques evolved for digital processes. At least one well-known European manufacturer of car radios has incorporated such a circuit with advantageous results.

**Frequency compensation** for listening level, since both the low and high audio frequencies require to be boosted for low volume control settings.

**Stereo decoder in portables** for earphones listening. BBC Designs Department produced such a thing about five years ago for our own use, since when Hacker have taken this idea up commercially with their "Silver Knight"

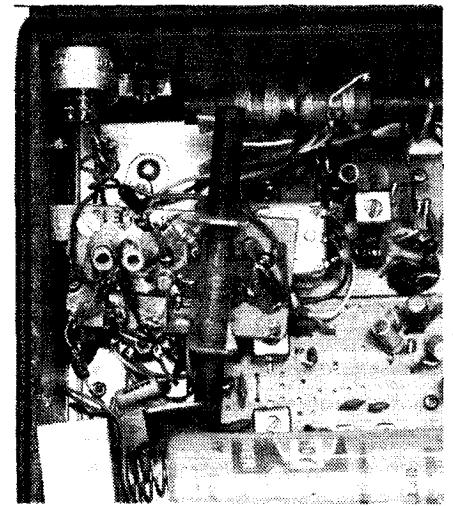

Fig. 8. Ferrite rod aerial for v.h.f./f.m. reception (the vertical one) in a portable set modified by the BBC Research Department.

model (Fig. 9), as have ITT and others. (A new Hacker model takes the proposition a stage further with a loudspeaker facing out from either end.)

"No-wires" stereo becomes possible if two f.m. portables are equipped with these small, relatively inexpensive decoders, provided each is also fitted with a left-channel/right channel switch; paired up they could be arranged to provide good stereo listening on their loudspeakers.

A cabinet which is rigid, sealed, waterproof, rugged and with improved acoustics.

**Rechargeable batteries** with inbuilt-charger.

The technology clearly already exists to bring all of these facilities into being. Which do the world's broadcasters consider the most important for (a) fixed set listening; (b) portables, and (c) car radios, and what are likely to be the price restrictions on the degree of sophistication? For its part, the BBC has had discussions with the British Radio Equipment Manufacturers Association (BREMA) as part of its continuing dialogue with that body, and has been encouraged by its response. BREMA has agreed to co-operate in any experiment the BBC decides to mount.

In conclusion, the author believes that since technology is no longer holding back either the broadcaster or the manufacturer, major developments in receiver design are possible; the receivers of the future are, however, only going to match our needs if the broadcaster specifies these clearly and works closely with the set-making industry.

#### Acknowledgements

The author wishes to record his thanks to S. M. Edwardson of the BBC's Engineering Research Department for his help and advice in preparing this article, and to Howard Newby, Managing Director, BBC Radio, and James Redmond, Director of Engineering, for their permission to publish it.

# BBC Matrix H

## Compatible system for broadcasting

by P. A. Ratliff, B.Sc., Ph.D and D. J. Meares, B.Sc.(Hons) *BBC Research Department*

During the past few years the BBC has been involved in assessing the performance of "surround sound" systems to determine whether the provision of a surround sound broadcast service would be viable. Most system proposals may loosely be called "quadraphonic" and they use four loudspeakers for reproduction, arranged as a fore and aft stereo set-up. To carry four loudspeaker signals to the listener, multiplexing techniques have been devised for discs in which four nominally independent signals are recorded, and a decoder, not unlike two stereo broadcast decoders in concept, is required to extract them. In circumstances where only two channels are available (as for conventional stereo discs, cassettes/tapes, and broadcasting), many proposals for channel-reduction matrices have been made whereby four loudspeaker signals are derived in the listener's decoder from two signals as recorded or broadcast.

The broadcasting of four independent signals would require either two complete stereo networks for each quadraphonic programme (as for example the BBC experimental broadcasts on 6th July and 23rd December, 1974, which used Radio 3 and 4 v.h.f. transmitters) or alternatively the inclusion of the additional signals by quadrature modulation of the 38kHz subcarrier and/or the addition of a further subcarrier. There are not enough Band II v.h.f. broadcast channels to permit the first-mentioned possibility on a permanent basis, and although the last has been discussed at some length<sup>1</sup>, including the transmission of only three signals<sup>2</sup>, there are serious problems in practice<sup>2,3</sup>.

To overcome some of these problems three-channel systems have been proposed which transmit the third signal with a reduced bandwidth and/or modulation level. These could substantially reduce the problem of incompatibility with existing stereo receivers, but at the same time would reduce the service area.

Most attention has therefore been

paid to two-channel matrix systems for possible broadcast use, as these would not, in principle, require any changes in distribution, transmission, or receiving apparatus. It would also be possible to record them with conventional stereo equipment. However, some loss of information is inevitable in mixing surround-sound signals into only two independent channels, and re-creation of the surround sound-stage, by means of a suitable decoder to provide four loudspeaker signals, has enjoyed a varying degree of success. The lack of loudspeaker signal separation inherent with any linear decoding matrix<sup>4</sup> has led to considerable effort being devoted to the design of variable matrices, whose decoding parameters are dependent upon the programme content. Such systems can only work ideally for one source direction at a time, and thus compromises must be made to enable a complex sound distribution to be accommodated.

Of paramount importance, the two encoded matrix signals must be capable of sensible reproduction, both directly in stereo and when summed in mono. This compatibility requirement, which is desirable in the disc, cassette, and tape market to eliminate the need for double inventories (i.e. the same programme material being released in both stereo and "quad" editions), becomes essential in broadcasting because all but a small proportion of the public will use existing stereo and mono receivers for the same broadcasts. Indeed, there must be no penalty paid by the existing stereo and mono audiences, who are likely to be in the majority for many years to come, if not permanently, in order to satisfy a minority quadraphonic audience. This requirement is perhaps the most important of a matrix system for broadcasting, and is the one which the commercial systems have failed to satisfy completely so far.

### Psychoacoustics

Initial studies at BBC Research Department concentrated on investigating the subjective properties of the human hearing mechanism, to find out the extent to which quadraphonic signals are capable of producing a subjective enhancement of the sound sensation for

the listener. Ideally, by surrounding the listener with sound information, a system should create a greater sense of realism and involvement in the programme. It is important to realise, however, that the programme must satisfy the listener subjectively, and merely the re-creation of the actual sound field at a suitable position in the recording environment may not be sufficient. This feature is, of course, well known in stereo reproduction, but applies equally for surround sound, because the lack of other perceptions of the recording environment (e.g. visual) often requires that the aural presentation be artificially exaggerated.

From a large number of subjective experiments, it was found that at normal listening levels the listener is almost equally sensitive to the loudness of a sound at any azimuth around him, and although his assessment of the location of a sound exhibits a left/right expansion in the rear of the sound-stage, he can co-locate two separate sounds to an accuracy of better than  $\pm 3^\circ$  for all stage azimuths. This last-mentioned factor is clearly the more important for surround sound reproduction, as the listener will not be so concerned about the true positions of the various sound sources in a programme, but will be likely to be more critical of their relative positions.

Studies were then made of quadraphonic presentation of sounds; in particular, the effects of combinations of signals with various amplitude and phase relationships typical of those produced by proposed matrix systems. Using conventional stereophonic sound-panning techniques\* for positioning a sound-image, a discrete system (i.e. four independent audio signals) is capable of giving good sound-image localization in the front and rear of the sound stage, but is sensitive to the listener's head position for the sides unless the listener turns to face the sound, particularly in non-reverberant surroundings. Fortunately, the acoustics of typical home living

\* The minimum number of channels which intuitively can provide independent directional information in one plane, i.e. a horizontal sound-stage.

\* A sound-image is moved between the two stereo loudspeakers by electrically altering the ratio of the sound signal fed to each loudspeaker, keeping the total power constant. This technique is also known as pairwise panpot mixing.



rooms serve to mitigate the last mentioned effect. When groups of directional microphones or channel reduction matrices are employed, more complex output signal configurations occur which can give rise to most unnatural sound effects, changing the location, definition and quality of the sound. On the other hand, with suitable control of these parameters, it is possible to enhance the sound image considerably.

Furthermore, it was necessary to examine the compatibility requirements of a sound system for stereo and mono reproduction. All the two-channel matrix proposals use phase difference between the left and right stereo signals, in addition to their amplitude ratio, to convey left/right and front/back directional information. For normal stereo the phase difference between the two signals is maintained at a nominal zero degrees, and it is well known that completely antiphase signals give rise to quite unpleasant, even nauseating, effects when the amplitude difference between the signals is small. Nevertheless, a much more detailed knowledge was required with the advent of matrix systems, and a comprehensive investigation into the effects of phase on stereo image formation was undertaken. As a result, the compatibility of any two-channel system can be predicted from a knowledge of its encoding parameters.

A useful pictorial representation of the stereo signal is given by Scheiber's sphere<sup>5</sup>, which maps the amplitude ratio ( $L/R$ ) and the phase differences  $\beta$  of the two-channel signals onto the surface of a sphere. This is facilitated by expressing the amplitude ratio as an angle, by the relationship  $\alpha = 2 \tan^{-1} |L/R|$ . Thus  $\alpha = 0^\circ$  when the signal is totally in the right channel,  $90^\circ$  when it is split equally between the left and right channels, and  $180^\circ$  when the signal is totally in the left channel. The right-hand half of the sphere is represented in Fig. 1, where the phase difference  $\beta$  is plotted as the angle around the circle, and the amplitude ratio  $\alpha$  is plotted as the radius of the circle, so that  $\alpha = 0^\circ$  (signal all in the right channel) is at the centre of the circle, and  $\alpha = 90^\circ$  (signal equal in the left and right channels) is on the circumference. The left-hand half of the sphere can be regarded as mirrored the other side of the paper with  $\alpha = 180^\circ$  (signal all in the left channel) at the centre of the circle on that side. Usually left/right symmetry pertains in stereophonic transmission systems and it is sufficient to examine only the one half of the sphere.

From the work on the effects of phase it was possible to divide the sphere into areas of impairment of stereo image quality, and in Fig. 1 three nominal regions are defined, namely negligible, slight, and severe impairment zones, as shown by the appropriately shaded areas. Impairment zones can be defined

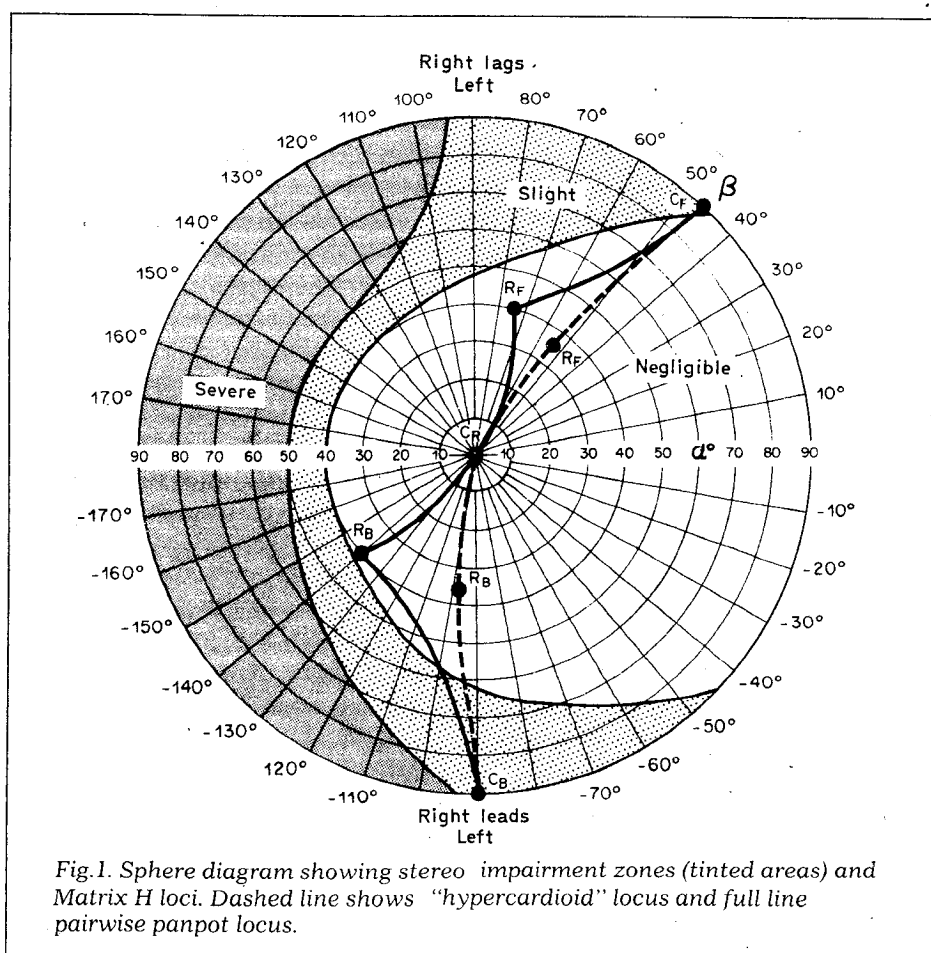

Fig. 1. Sphere diagram showing stereo impairment zones (tinted areas) and Matrix H loci. Dashed line shows "hypercardioid" locus and full line pairwise panpot locus.

for mono reproduction, but these are less severe, resulting only in a reduction of level for large values of the two-channel phase difference  $\beta$  thus affecting the balance in mono of sounds from different encoding azimuths.

The compatibility problems found with earlier matrix system proposals could now clearly be seen when the system loci were plotted on the sphere; they all transgressed into the slight and/or severe impairment zones to too great an extent. What was required was a system whose encoding locus lay principally within the negligible impairment zone, having a sensible image distribution in stereo reduction, and yet retaining the capability to be decoded in surround sound with both left/right and front/back sound-stage discrimination.

### Matrix H encoding

The requirement was met with the development of Matrix H<sup>6,7</sup> at the Research Department. The two-channel encoding matrix may be defined in terms of the position of the sound source in the surround sound stage to give left and right channel coded signals of<sup>8</sup>

$$\begin{bmatrix} L \\ R \end{bmatrix} = \begin{bmatrix} 0.63 \angle -7.5^\circ & 0.43 \angle +73^\circ & 0.63 \angle -7.5^\circ \\ 0.63 \angle +7.5^\circ & 0.43 \angle -73^\circ & 0.63 \angle +7.5^\circ \end{bmatrix} \begin{bmatrix} 1 \\ \cos \theta \\ \sin \theta \end{bmatrix}$$

where  $r \angle \phi$  represents a quantity of magnitude  $r$  and phase-shift  $\phi$  relative

to an arbitrary reference, and  $\theta$  is the azimuth angle of a unit amplitude sound source measured in a clockwise sense from the centre-front direction of the sound stage. The first component represents the mono, or omnidirectional response, the second the front/back directional response, and the third component represents the left/right directional response. The locus of this encoding equation on the sphere is shown by the dashed line in Fig. 1, with marks for the encoding positions of the eight cardinal sound-stage locations ( $C_F, R_F, C_R, R_B, C_B$  shown, and  $L_B, C_L, L_F$  are on the other side of the sphere to the corresponding right-hand positions). This locus also corresponds to that obtained using coincident group-microphone techniques for recording the natural sound-field at a single location.

It is common studio practice however, to position a sound-source electrically by panning a source signal between pairs of channels (pairwise panpot mixing). In quad mixing such panning is usually arranged to take place between the four corner channels  $L_F, R_F, L_B, R_B$ , and the equation for Matrix H given above has to be adapted to accommodate these inputs. It then takes on the form

$$\begin{bmatrix} L \\ R \end{bmatrix} = \begin{bmatrix} 0.94 \angle 10^\circ & 0.34 \angle 65^\circ & 0.94 \angle -25^\circ & 0.34 \angle -115^\circ \\ 0.34 \angle -65^\circ & 0.94 \angle -10^\circ & 0.34 \angle 115^\circ & 0.94 \angle 25^\circ \end{bmatrix} \begin{bmatrix} L_F \\ R_F \\ L_B \\ R_B \end{bmatrix}$$

The locus of this equation is shown by the solid line in Fig. 1 for pairwise panpot mixing, and is the form in which Matrix H is usually instrumented. This

<sup>8</sup>An explanation of matrix notation in relation to surround systems may be found in reference<sup>1</sup>.

configuration also provides ideal group-microphone encoding, following the dashed curve, for four coincident hypercardioid-response microphones arranged to point in the directions of the corresponding loudspeakers used in quadrasonic reproduction. In practice four cardioid-response microphone elements are used, and their signals are mixed to give the required hypercardioid-response signals, with a forward/backward response ratio of 5.83.

For maximum front/back discrimination the centre-front ( $C_F$ ) and centre-back ( $C_B$ ) encoding points should be diametrically opposite one another on the sphere, as are the centre-left ( $C_L$ ) and centre-right ( $C_R$ ) encoding points. However, this would involve using too much of the slight and severe impairment zones, thus seriously affecting compatibility, and so the Matrix H loci have been bent so that 80% of the locus lies in the negligible impairment zone. None of the locus enters the severe impairment zone and only the region near  $C_B$  significantly enters the slight impairment zone. This last-mentioned feature is used to advantage in that even the stereophonic listener gains an impression of the depth of the sound stage.

The distribution of encoding azimuths around the locus is arranged to give sensible localization in stereo as well as correct localization in quad. Fig.2 shows experimental results for the stereo image localization and image spread, or diffuseness, using Matrix H and, for comparison, using a direct stereo fold-down from a four-channel discrete system. (The corresponding front and back signals are simply summed to give what is known as discrete-blend stereo.) With discrete-blend stereo, full stage width is given to the front and back quadrants of the sound stage whilst the side quadrants are compressed to two points. This usually results in a very "ping-pong" stereo presentation of the programme. Also there is no differentiation between front and back quadrants, which can make the sound presentation dull or even confusing.

Matrix H, on the other hand, gives a more uniform distribution of the sound-stage whilst maintaining prime emphasis on the all-important front sector. The front quadrant spans most of the stereo stage with  $C_L$  and  $C_R$  actually at the loudspeakers, and the rear corner positions are arranged so that overwidth stereo may be obtained, particularly when using pairwise-panpot mixing. Thus, images may be localized outside the space enclosed by the loudspeakers and, without generating unpleasant phase effects, a "super stereo" can be produced when desired. Centre-back is reproduced somewhat spread compared with  $C_F$  and also displaced slightly to one side. This diffuseness of rear images is subjectively very good in a complex programme mix in that it gives a more distant

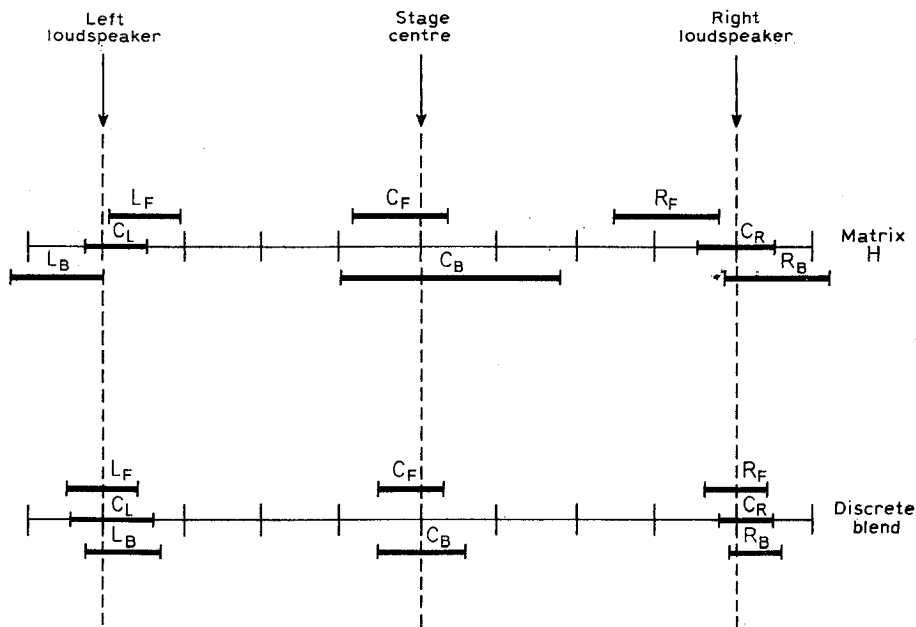

Fig.2. Stereo image localization and spread for Matrix H and "discrete blend".

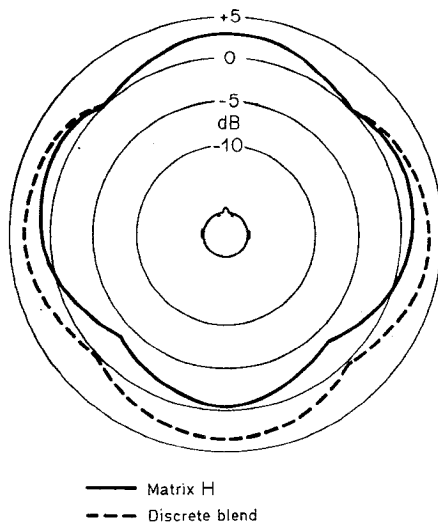

Fig.3. Variation of mono signal with sound-stage location.

perspective and hence creates depth to the stereophonic sound-picture, with the front sound stage appearing more prominent.

In monophonic reproduction, Fig.3, Matrix H gives a small bias towards the front of the sound-stage when compared with discrete-blend mono (obtained by summing the four-channels of a discrete system). With pairwise panpot mixing, a maximum level reduction of 3.6dB with respect to the front corner stage locations occurs at the rear corner positions. This is a highly desirable feature for stage/ambience (e.g. concert hall) recordings, where a reduction of ambience level is required in mono to retain a subjectively satisfactory sound balance with principal sources. In surround presentations, where such a level drop would not be desirable, the rear corner sounds

are simply panned inward slightly toward stage centre, equivalent to about -15dB cross-mix to the opposite front corner encoding point. This corresponds to moving the rear corner encoding point on the sphere towards that for coincident microphone recording. Thus "quad" presentation is not substantially altered, and the only penalty paid is that the overwidth effect in stereo is reduced slightly.

**Matrix H decoding**

To obtain surround sound, a suitable decoder is required to extract the directional information from the coded two-channel signal. A linear decoding matrix may be formed by taking the complex conjugates of the row elements of the encode matrix and writing them down as the column elements of the decode matrix

$$\begin{bmatrix} L'_F \\ R'_F \\ L'_B \\ R'_B \end{bmatrix} = \begin{bmatrix} 0.94 \angle -10^\circ & 0.34 \angle 65^\circ \\ 0.34 \angle -65^\circ & 0.94 \angle 10^\circ \\ 0.94 \angle 25^\circ & 0.34 \angle -115^\circ \\ 0.34 \angle 115^\circ & 0.94 \angle -25^\circ \end{bmatrix} \begin{bmatrix} L \\ R \end{bmatrix}$$

This results in an overall transfer function for the Matrix H system of

$$\begin{bmatrix} L'_F \\ R'_F \\ L'_B \\ R'_B \end{bmatrix} = \begin{bmatrix} 1.00 \angle 0^\circ & 0.64 \angle 55^\circ & 0.79 \angle -40^\circ & 0.19 \angle 163^\circ \\ 0.64 \angle -55^\circ & 1.00 \angle 0^\circ & 0.19 \angle -163^\circ & 0.79 \angle 40^\circ \\ 0.79 \angle 40^\circ & 0.19 \angle 163^\circ & 1.00 \angle 0^\circ & 0.64 \angle -90^\circ \\ 0.19 \angle -163^\circ & 0.79 \angle -40^\circ & 0.64 \angle 90^\circ & 1.00 \angle 0^\circ \end{bmatrix} \begin{bmatrix} L_F \\ R_F \\ L_B \\ R_B \end{bmatrix}$$

Low separation figures are obtained between adjacent outputs; this characteristic is typical of two-channel linear matrix systems, as only two outputs can be completely isolated. However, in the case of Matrix H decoding the signal separations obtained are not symmetrically disposed, and were optimized by taking account of psychoacoustic properties so that a centrally-seated, forward-facing listener obtains optimum results. In addition, the phase relationships between these signals were modified to further enhance the directionality of sound sources and substantially eliminate unpleasant

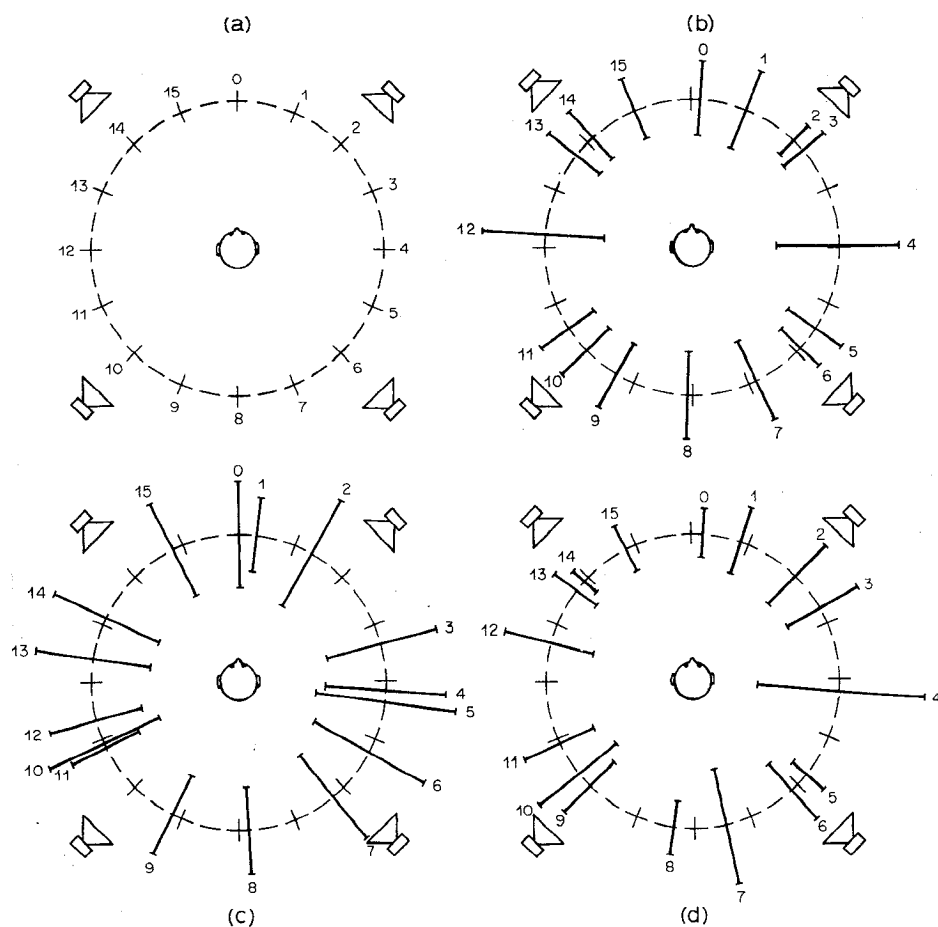

Fig. 4. "Quad" image localization and spread (length of radial bars). (a) Ideal test-image positions, (b) four-channel results, (c) two-channel Matrix H linear decoder, and (d) Matrix H with programme-dependent decoder.

phase effects which can occur with basic matrix decoding due to large phase differences between associated signals.

The performance of this decoder was initially assessed in single-source localization tests, in which the listener was asked to estimate the position and spread, or diffuseness, of the sound-image produced when a source-signal was encoded at any one of 16 azimuth positions. Fig. 4(a) shows the ideal locations of the test sound-images (numbered 0 to 15, position 0 corresponding to the  $C_F$  position) and Fig. 4(b) shows the corresponding mean assessed image positions together with their image spreads, for a discrete four-channel system.

A reasonable distribution of images is obtained, although the side quadrant positions are more diffuse and sensitive to positioning. In comparison, Fig. 4(c) shows results for the basic linear Matrix H system. Although there is more variation in absolute positional accuracy, a fairly uniform image distribution is maintained and hence relative sound localization is good. Image spreads are greater for Matrix H, notably in the

corner locations, but again remain fairly uniform around the whole sound stage.

These results were substantially better than for any other linear matrix system tested. However, a limitation of linear matrix decoding is that it is sensitive to listening position if the correct directionality of sounds is to be maintained. Also the sound stage is reproduced too close to the listener. Nevertheless, linear Matrix H creates a pleasing sound sensation, even when listening off-centre, possessing the warm and spacious characteristics of good surround sound reproduction.

For a larger effective usable listening area, signal separations greater than can be provided by linear matrix decoding are required. These can be achieved by a programme dependent technique in the decoding process. The decoder is still based upon the linear matrix of the system, but circuits are introduced which detect the principal (loudest) sound-source location and vary the decoding parameters to enhance its subjective localization.

In principle, an enhanced two-channel matrix decoder is capable of reproducing sources at any single location with the same fidelity as a four-channel discrete system. However, it is a fundamental limitation of such matrix systems that sources at different locations cannot all be reproduced faithfully at the same time. In fact, some of the early "enhanced" decoders caused quite unpleasant effects, such as severe image instability and/or level variations, but if the variable decoding mechanisms are

suitably controlled, e.g. the gain-laws and time-constants selected with care, these objectionable effects can be reduced almost to the point of inaudibility.

It has been found that a variable-matrix enhancement technique, first developed by Sansui<sup>8</sup> (see for example reference 9) is the most successful to date. The detailed mechanics of such decoding are complex and there are many possible variations, but details of such a technique for matrix H and a suitable decoder are to be published in a subsequent issue of *Wireless World*. With Matrix H, however, the advantages of a good linear decoding matrix are combined with those of variable matrix enhancement, so that a good decoding performance is obtained not only when there is a principal sound source to command the enhancement circuits, but also in an ambience-sound situation when there is no dominant sound source to cause the decoding matrix to vary from its quiescent linear condition. This obviously eases the compromises that have to be made in decoder design to make it perform well with both simple and complex sound-stage arrangements.

Subjectively, when enhancement is applied to a Matrix H decoder, the sensitivity to listener position is reduced, and the "closing in" characteristic of the linear matrix disappears. Fig. 4(d) shows image localization and spread results obtained for an experimental enhanced Matrix H decoder. Positional accuracy is close to that of a discrete four-channel system and image spreads are very similar. Assessments on pre-mixed programme material also show a surround-sound performance similar to that of a discrete system is obtained. The performance is better than that from the best commercial systems with programme-dependent decoding, but with the significant advantage that it combines with a highly compatible stereo and mono presentation from the same encoded signals.

### System assessment

Matrix H had proved to be highly compatible and effective in the laboratory, but it was then necessary to find out whether the system was readily useable in practice, under the normal processes of programme production in existing studio installations. Also it was important to set up an impartial experiment to find out whether any of the other system proposals had developed to the point where they might in practice be equally, or better suited to a surround-sound broadcast service. The BBC invited the proponents of all known practical systems to submit their equipment and supervise its installation. The following accepted: BMX, SQ, QS and Matrix H.

Programme production teams selected material recorded on 16-track master-tapes, some recorded using indivi-



dual spot microphones and some recorded using coincident groups of microphones, and were asked to make surround-sound programmes, suitable for compatible broadcasting, with each of five anonymous systems, one of which was a discrete four-channel system which served as a reference. They had to mix the programme independently through each system to try and attain their desired intention, making compromises where necessary to maintain good stereo and mono compatibility.

The resulting programme mixes were recorded and later played back for independent assessment of the quad, stereo, and mono performances, still as anonymous systems to the listeners. The listeners were told of the producers' broad intentions, in the form of an ideal stage layout chart for each programme item and were asked to score each system by placing a mark at the appropriate point on a linear scale running from "bad" to "good". Fig. 5 shows the averaged results for separate assessments of the quad, stereo, and mono performances together with an overall assessment. As the systems were presented in a randomized order in each set of tests, listeners were then told which of their results pertained to the same, but still anonymous, system so that they could give their overall assessment.

Listening in quadraphony Fig.5(a), the discrete four-channel system came out best, with Matrix H a close second; and the three other systems (labelled X, Y and Z) were significantly worse. In stereo, Fig.5(b) Matrix H was clearly preferred, and in mono the preference for Matrix H was slight. Note that the direct fold-down of the discrete four-channel system (discrete blend) was not particularly well liked for its stereo and mono performances, as was predicted. Finally, Fig.5(d) shows the average of listeners overall assessments and confirms that as a broadcast system Matrix H is the best viable choice.

### Broadcast developments

Matrix H encoded programmes have been made by the BBC and other European broadcasters; some of the Promenade Concerts broadcast during the 1976 season were encoded by Matrix H. Recordings of the latter were made off-air, using a conventional v.h.f. stereo receiver, and later compared with recordings made on site at the recording environment. Such comparisons provided confirmation that the BBC's normal stereo broadcast network can handle Matrix H transmissions without problem.

The advantage of the two-channel compatible system is that surround-sound broadcasting can take place over existing stereo networks and transmitters, and all existing stereo facilities can continue to be used. Most importantly, this includes the listener's equipment, and not only his v.h.f. stereo receiver, but also his disc and tape apparatus.

### (a) QUADRAPHONIC PERFORMANCE

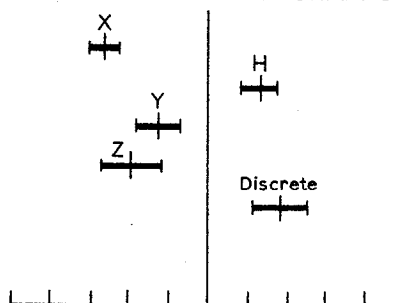

### (b) STEREO PERFORMANCE

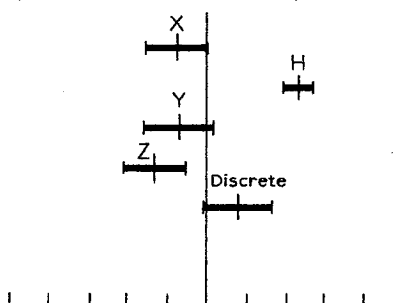

### (c) MONO PERFORMANCE

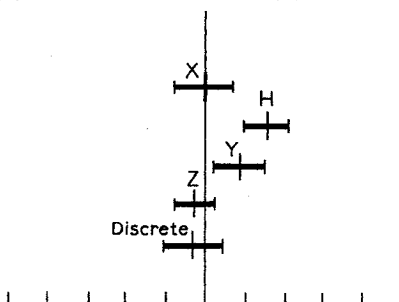

### (d) OVERALL PERFORMANCE

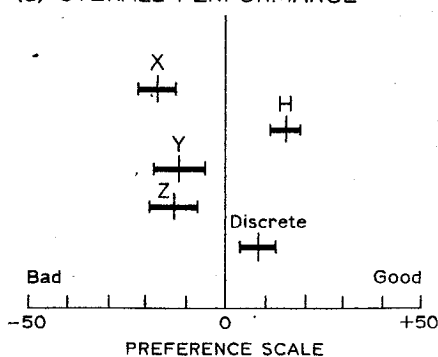

Fig.5. System comparison tests showing listener's preference for "serious" music (horizontal bars show standard deviations).

Nothing is rendered redundant, but it is of course necessary to provide a decoder, loudspeakers, and amplifier, to gain the extra sound dimension.

Systems using a third or fourth signal could not be handled by existing receivers or recording apparatus, and the additional cost to both listener and broadcaster of adding extra signals would be large. The question would be whether any achieved improvement in performance over that of two-channel Matrix H could be considered worth-

while. In the unlikely event of it becoming possible to devise a new broadcasting system, with the necessary extra bandwidth and improved s/n Matrix H could, of course, readily be expanded to provide three or even four transmission signals. Even so, as it would retain its present excellent stereo and mono compatibility and the present high standard of quadraphony for existing listeners, one wonders how many listeners would consider the additional expense of three- or four-channel receiving apparatus justifiable.

The BBC intends to broadcast a number of experimental programmes using Matrix H throughout the remainder of 1977, and the early part of 1978 at least. Details of these will be published in *Radio Times*. Listeners who wish to decode these broadcasts to give the full surround-sound effect will be interested in the forthcoming *Wireless World* article describing a suitable decoder. Existing decoders designed for use with other systems will not normally provide a satisfactory performance without modification\*† and naturally optimum performance can only be expected from a purpose-built decoder.

**Acknowledgements.** The authors wish to thank the Director of Engineering of the BBC for permission to publish this article and are also grateful to the many people who have helped during the development of Matrix H, in particular Messrs Crompton, Gaskell, Harrison, and Wright.

### References

- Carey, M. J. and Sager, J. C. Quadrasonic broadcasting — current proposals and the way ahead. *Wireless World* Vol.80 November 1974, pp.422-5.
- Meares, D. J. Quadrasonic broadcasting — an alternative view *Wireless World* Vol.81, February 1975, pp.65/6.
- Netzband, R. Multiplex systems for v.h.f./f.m. sound broadcasting. *E.B.U. Review*, (Technical,) October 1974, pp.225-9.
- Shorter, G. Four-channel stereo. *Wireless World*, Vol.78 January 1972 pp.2-5 and February 1972, pp.54-7.
- Scheiber, P. Analysing phase-amplitude matrix. *Journal of the Audio Engineering Society*, vol.19 November 1971, pp.835-9.
- British Patent Application no. 34839/74.
- Meares, D. J. and Ratliff, P. A. Development of a compatible 4-2-4 quadrasonic matrix system, Matrix H. *E.B.U. Review* (Technical), October 1976, pp.208-17.
- British Patent No. 1,402,320.
- Heller, D. Surround-sound decoders, Parts 3 and 4 (QS Variomatrix). *Wireless World*, Vol.82 August 1976 pp.57-9 and September 1976 pp.53-6.

\* However the latest NRDC proposals (system 45J, see last issue) are close to Matrix H encoding specification; this should enable a suitably designed decoder to give a satisfactory performance with either system.

† See elsewhere in this issue for Variomatrix modification details.—Ed.

# World of Amateur Radio

## Changes in amateur examination

Since its introduction in 1946 the Radio Amateurs' Examination of the City and Guilds of London Institute — the examination which must be passed to obtain either a Class A or Class B licence in the United Kingdom — has been conducted as a three-hour written paper, divided into two parts: Part 1 with two compulsory questions; Part 2 with eight questions of which six should be attempted.

But from 1979, City and Guilds are expected to introduce a new format to the examination based on objective tests containing multiple-choice questions, i.e. four possible answers are provided and the candidate indicates which he thinks is the right one. This technique, if pitched at the right level, can provide a revealing assessment of the knowledge of a candidate without reference to his "literary" abilities and can result in more consistent marking. Such an approach would seem very suitable for an examination taken by candidates who range from about 14 to over 70 years of age.

In preparation for these changes the City and Guilds is inviting readers in the London area to take part in pre-tests of the new form of exam on May 3, as follows:

"The RAE from 1979 will be in the form of Objective Tests containing multiple-choice questions. If you are preparing for your amateur licence on your own and live in the London area, you may be able to assist. It is the Institute's policy to pre-test objective questions, trying them out on candidates who have reached examination standard. Pre-tests are intended to test the performance of individual questions and syllabus coverage. Information is obtained which assists the Institute's reviewing panels in judging whether each individual question should be included in the question bank for use in future exams . . . pre-tests must be administered to a sample of students representative of those who will take the exam. Many would-be radio amateurs prepare for exams without fol-

lowing a college course and the Institute invites such candidates who live in the London area to assist.

"The pre-tests are to be held at the Institute, 76 Portland Place, W1, on Tuesday, May 3, from 10.15 a.m. As well as helping us the tests may help would-be examinees to revise their work and gain some exam experience. If you are willing to assist please telephone Miss Jackie Clifford (01-278 2468, ext. 491). Invitation will be issued to eligible candidates."

## Promoting RTTY

The British Amateur Radio Teleprinter Group seems to have stepped up its efforts to encourage more use of r.t.t.y. by British amateurs. Apart from publishing information on the principles and practice of r.t.t.y., BARTG has recently established a team of lecturers prepared to talk on r.t.t.y. to amateur radio clubs. Requests should be made to J. P. G. Jones, GW31GG, Hon. Sec. BARTG, 40 Lower Quay Road, Hook, Haverfordwest, Dyfed SA62 4LR.

BARTG is holding its annual convention on Saturday, May 21, at the Village Hall, Meopham, Kent, where there will be lectures, trade stands, bring-and-buy stall and a "tape factory". Trains arriving at Meopham station before 1315 hours will be met by transport.

An American amateur who first demonstrated a radio teleprinter system as long ago as 1921 has recently been honoured by the Radio Club of America. The club's 1976 Sarnoff Medal has been awarded to Captain W. G. H. Finch, first licensed in 1912 as 8MK and 8IE. His early r.t.t.y. was based on his invention of a highly sensitive relay.

## Silver Jubilee prefix

To mark the Queen's Silver Jubilee the Home Office is authorizing all British Class A and B amateurs to use the special commemorative prefix "GE" instead of the usual G, GM etc. in all parts of the UK from 0001 hours on Saturday, June 4 to 2359 hours on Sunday, June 12. This is the first time a special prefix has been made generally available to UK amateurs to mark a national event and the Home Office state that it will not set a precedent.

## Scanning the bands

Sunspot activity seems to be rising again (at last!) with h.f. conditions in December, January and February benefiting from the small but noticeable improvement. Particularly fortunate was the ARRL DX contest (c.w. section) on February 10-20 with many of the new "N" two-letter calls pounding in on 7, 14 and 21 MHz. Maritime activity on 21MHz also seems to be on the increase: recent contacts have been with JF3HAN/mm near Hong Kong;

JA4GY/mm in the Arabian Sea; and YU3EO/mm a freighter in mid-Atlantic.

It is reported that during the American bicentennial year (1976) Dick Spencerley, KV4AA — operating as AJ3AA — made some 35,000 contacts, an average of nearly 100 a day, from the Virgin Islands — surely a record!

Microwave Associates are producing a 20mW Gunn-diode 10GHz transceiver specifically for the amateur. It is supplied with (or without) a 17dB gain horn antenna, Schottky diode mixer and circulator. It can put an amateur on the 10GHz band at costs very favourable in comparison with those for factory equipment at lower frequencies. Details are in "Bulletin 7624" issued by the firm.

"World Radio Club" — the BBC World Service programme for DX enthusiasts and amateurs — celebrated its 500th weekly edition with one of the few audience participation broadcasts ever produced at Bush House. Over 32,000 listeners have joined the club since it began in July 1967.

"Employers in the communications industry have reason to be grateful to the RSGB for the enthusiasm and expertise implanted in many of their young apprentices through membership of local radio clubs and the society itself. I hope more firms will take a closer and more practical interest in the RSGB in the future" — Lord Wallace of Coslany at his installation as 1977 president of the RSGB held at the Palace of Westminster.

## In brief

The new honorary secretary of the Radio Amateur Invalid and Bedfast Club is Mr H. R. Boutle, G2CLP, 14 Queen's Drive, Bedford MK41 9QB . . . A feature of the RSGB International Radio Communication Exhibition and Convention at Alexandra Palace, London on May 6-8 will be a "Members' Mart" on May 8 in the west corridor . . . Northern Radio Societies' Association annual convention and exhibition — sponsored by a number of radio societies in the north of England, is at Belle Vue, Manchester, on Sunday, April 24. A record number of trade exhibitors and club standards are expected . . . The 3rd European Conference for Radio Amateurs under the aegis of the German society DARC takes place May 27-30 at Wolfsburg. Earlier conferences were held in 1968 and 1972 . . . Harold Woodhead, G2NX, who died recently was one of the first, if not the first, amateur to use single-sideband in the UK . . . A busy time for mobile rallies: May 1 Spalding Tulip-Time Rally (Gleed Boys School, Spalding); May 22 Welsh Mobile Rally (Barry Rugby Football Ground) and Northern Mobile Rally (Victoria Park Hall, Keighley); May 29 Suffolk Wireless Revival (Ipswich), Southend (Fitzwimarc School, Rayleigh) and a Hull rally.

PAT HAWKER, G3VA

# Electrolytic capacitor tester

Automatic instrument offers a reform facility and meter display

by A. Drummond-Murray

**This instrument uses a charge injection technique to develop a voltage across the capacitor under test. The voltage is measured on a calibrated meter and no balancing or adjusting is required except for range selection. A reform facility allows an old or unused capacitor to have a voltage applied for about 15s which re-polarizes the dielectric before a measurement is made. An indication of leakage is also provided by the meter movement which is buffered by a f.e.t.-input amplifier.**

Electrolytic capacitors depend on a dielectric formed on a aluminium or tantalum electrode by a thin layer of oxide. This dielectric requires polarizing to maintain its insulating properties and long periods of rest can result in de-polarization, a high leakage current and even total breakdown. Fortunately, the dielectric layer can be restored by applying a polarizing potential to the capacitor for at least five minutes via a current limiting resistor. This process is known as reforming. If a capacitor is to be tested and has started to de-polarize, a reforming period is necessary before any meaningful results can be obtained. The tester is provided with a reform facility which charges the capacitor to +12V via a 1200 $\Omega$  resistor for about 15 seconds prior to the capacitance measurement. Although this period is too short for complete reforming, it is sufficient for most capacitors to recover enough for testing. The main property to suffer from incomplete reforming is leakage current. If, on test, a capacitor exhibits a high leakage current, a second reform period will often suffice. If no such improvement is apparent, the capacitor is faulty and unlikely to benefit from a prolonged reform. A short tone from the instrument indicates that the reform period is complete. Three l.e.d.s indicate the state of the circuit during the test process. A green l.e.d. indicates that the reform process is ready to start and a red type indicates that an excessive current is flowing during the polarizing period. This facility is useful for detecting short circuit capacitors.

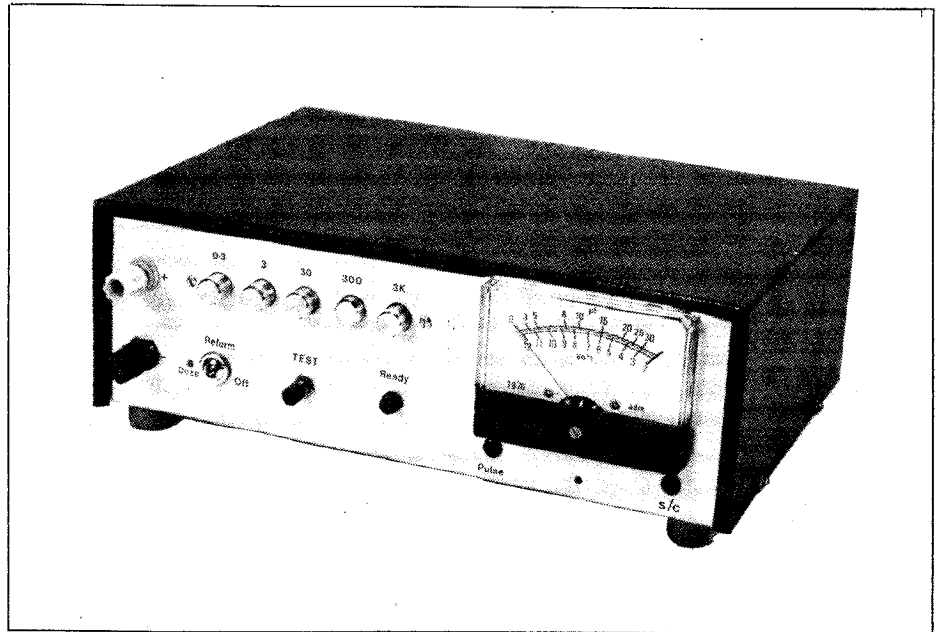

During the measuring cycle, a further l.e.d. flashes when the test capacitor is being charged.

An equivalent circuit is shown in Fig. 1. The charge period on any range is the same for any unknown capacitance, and the voltage developed across the capacitor is proportional to its capacitance. If this voltage is measured from 0V instead of 12V, the capacitance increase is indicated as an increased voltage. This voltage rises exponentially. Fig. 2 shows the sequence of events following a start pulse. After a polarizing potential is applied, the capacitor is completely discharged through a circuit which limits the peak current to 100mA. A finite charge is then injected into the capacitor and the voltage is measured on a calibrated meter. The rate of decay is taken as a measure of internal

leakage. A complete circuit of the tester is shown in Fig. 3.

Input impedance of the measuring circuit is important because of the shunting effect which occurs. Fortunately, modern operational amplifiers are ideally suited for producing high input

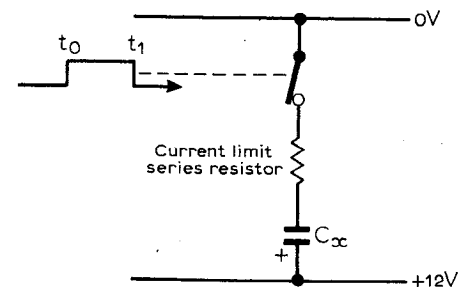
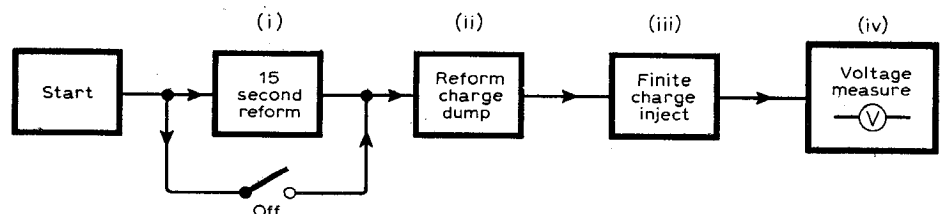

Fig.1. Simplified circuit of the tester

Fig.2. Block diagram of circuit operation.





impedances. Simple devices like the 741 can be made to have a high input impedance, but the bias current taken by the input transistors can still cause the capacitor voltage to vary. F.e.t.-input op-amps do not suffer from this problem, and the input resistance is greater than 1000MΩ. Using a f.e.t.-input amplifier the meter reading obtained with a 1μF polyester capacitor had no change after 20 minutes. Leakage current through any conventional electrolytic capacitor is certain to be many times higher than this, so the meter-drive loading may be disregarded.

In general the range of the instrument is altered by varying the charge current period. Because each range is ten times larger than the previous one, the charge injected increases by the same proportion, so the scale calibration is correct for all ranges. Calibration of the instrument is achieved by using known values of capacitance and marking the scale accordingly. Mullard 10% 100V polyester types with values 0.33μF, 0.47μF and 1.0μF ×3, were used and checked on a capacitance bridge and found to be within ±5%. These are quite adequate for calibration in view of the wide tolerance of electrolytic types (up to +100% -50%). On the 3000μF range a ten-fold increase in charge current is used to avoid a 47μF non-electrolytic capacitor, which is both large and expensive. The charging current is determined by the series resistance in the circuit and by the exponential rise in voltage across the capacitor. On the 3000μF range the

initial current is a little under 100mA, so a well regulated supply is required to prevent a momentary fall in voltage as the 100mA demand is met.

The timing sequences are controlled by three monostable multivibrators. The initial forming period is determined by the 1000μF electrolytic capacitor on IC<sub>1a</sub> and will vary with the component used. If it is not desired to reform a capacitor before testing, the 1000μF capacitor is switched out of circuit, and the period reduces to a few nanoseconds. At the completion of this period the test capacitor is fully discharged. The duration of the discharge cycle is 0.25s on all except the 3000μF range which is increased to 2s. Capacitor C<sub>5</sub> is switched in parallel with the existing timing capacitor, C<sub>4</sub> for this purpose.

As discussed earlier, the accuracy of the instrument depends on each range having a ten-fold change in the amount of charge injected during the test period. Stable capacitors are therefore required on the timing multivibrator, IC<sub>3</sub>. Polycarbonate and polystyrene capacitors are particularly suitable but mylar, paper or ceramic devices are not recommended.

On all but the 3000μF range, the test capacitors are charged through a series 1.2kΩ resistor and consequently the accuracy with which the periods change directly affects the meter calibration from range to range. On the

3000μF range the test capacitor is charged through 120Ω, formed by the addition of 135Ω in parallel with R<sub>12</sub>. Two extra resistors are used to prevent aging due to the relatively high peak current of 100mA.

A monostable is used to drive the precision charge circuit because this device is recommended by the manufacturer for stability and repeatability.

Operation of the circuit is indicated by the pulsing of LED<sub>2</sub>. During the reform period, current passing through R<sub>12</sub> is monitored by Tr<sub>4</sub>. If the V<sub>be</sub> exceeds 0.7V then Tr<sub>4</sub> turns on LED<sub>3</sub>. Resistor R<sub>14</sub> limits the base current and prevents Tr<sub>4</sub> from shunting R<sub>12</sub>. The i.e.d. is illuminated fully when the capacitor current exceeds about 5mA. During the discharge sequence, Tr<sub>2</sub> is turned on by Tr<sub>3</sub> and Tr<sub>1</sub> remains cut off. When Tr<sub>2</sub> turns on, the discharge path is completed via R<sub>12</sub> and R<sub>13</sub> in series. Because R<sub>12</sub> is in parallel with a diode which will be forward biased, the maximum potential across R<sub>12</sub> is limited to 0.7V so the remainder of the voltage drop will be across R<sub>13</sub> which is a low resistance. Diode D<sub>3</sub> removes R<sub>12</sub> from the discharge path during the initial current flow, and until the capacitor voltage falls below 0.7V. Schmitt trigger IC<sub>4a</sub> is connected as a simple oscillator producing a continuous rectangular waveform. The second Schmitt trigger IC<sub>4b</sub> isolates the oscillator from the loudspeaker. The trailing edge of the reform cycle pulse at Pin 13 of IC<sub>1a</sub> has a positive-going edge which is differentiated by C<sub>2</sub>, R<sub>5</sub> and used to switch the oscillator output to the loudspeaker. It

Fig.3. Complete circuit of the capacitor tester. Switches 3<sub>a</sub> and 3<sub>b</sub> only close on range M of switch 3<sub>c</sub>.

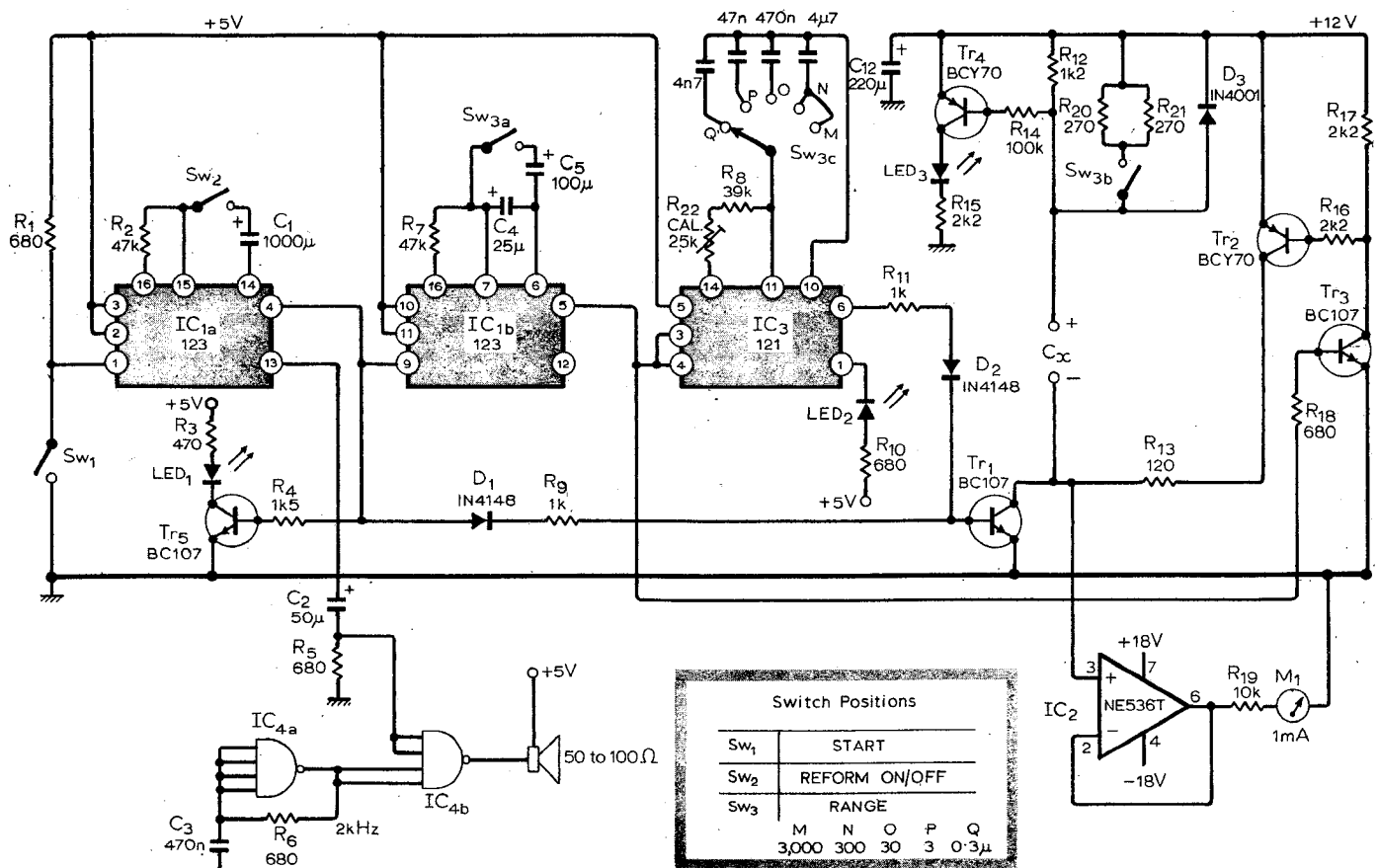

**Components list**

|                       |                                     |
|-----------------------|-------------------------------------|
| R <sub>1</sub>        | 680Ω                                |
| R <sub>2</sub>        | 47k                                 |
| R <sub>3</sub>        | 470Ω                                |
| R <sub>4</sub>        | 1.5k                                |
| R <sub>5</sub>        | 680Ω                                |
| R <sub>6</sub>        | 680Ω                                |
| R <sub>7</sub>        | 47k                                 |
| R <sub>8</sub>        | 39k                                 |
| R <sub>9</sub>        | 1k                                  |
| R <sub>10</sub>       | 680Ω                                |
| R <sub>11</sub>       | 1k                                  |
| R <sub>12</sub>       | 1.2k                                |
| R <sub>13</sub>       | 120Ω ¼W                             |
| R <sub>14</sub>       | 100k                                |
| R <sub>15,16,17</sub> | 2.2k                                |
| R <sub>18</sub>       | 680Ω                                |
| R <sub>19</sub>       | 10k                                 |
| R <sub>20,21</sub>    | 270Ω                                |
| R <sub>22</sub>       | 25k preset                          |
| C <sub>1</sub>        | 1000µF 10V                          |
| C <sub>2</sub>        | 50µF 10V                            |
| C <sub>3</sub>        | 0.47µF 10V                          |
| C <sub>4</sub>        | 25µF 10V                            |
| C <sub>5</sub>        | 100µF 10V                           |
| C <sub>6</sub>        | 4700pF polystyrene                  |
| C <sub>7</sub>        | 47nF                                |
| C <sub>8</sub>        | 0.47µF polycarbonate                |
| C <sub>9</sub>        | 4.7µF polycarbonate                 |
| C <sub>10</sub>       | 2000µF 25V                          |
| C <sub>11</sub>       | 100µF 25V                           |
| C <sub>12</sub>       | 220µF 25V                           |
| C <sub>13,14</sub>    | 0.1µF disc ceramic                  |
| D <sub>1,2</sub>      | 1N4148                              |
| D <sub>3</sub>        | 1N4001                              |
| Tr <sub>1,3,5</sub>   | BC107                               |
| Tr <sub>2,4</sub>     | BCY70                               |
| LED <sub>1</sub>      | Green                               |
| LED <sub>2,3</sub>    | Red                                 |
| IC <sub>1</sub>       | SN74123N                            |
| IC <sub>2</sub>       | NE536 (or RS Components 'FET MOPA') |
| IC <sub>3</sub>       | SN74121N                            |
| IC <sub>4</sub>       | SN7413N                             |
| IC <sub>5</sub>       | MC7812CP                            |
| IC <sub>6</sub>       | MC7805CP                            |
| Bridge rectifier      | 100V p.i.v., 1A                     |
| <b>Miscellaneous</b>  |                                     |
| Loudspeaker           | 50-100Ω min                         |
| Panel meter           | 1mA                                 |
| Transformer           | 240/15.0.15 1A                      |
| Sw <sub>1</sub>       | SPSM                                |
| Sw <sub>2</sub>       | SPSM                                |
| Sw <sub>3</sub>       | 3P5W                                |
| Fuse                  | 250mA                               |

**Prototype scale calibration**

|  |                         |
|--|-------------------------|
| <i>Capacitance/terminal voltage meter scaled 0-1</i> |                         |
| 0µF  | 0                       |
| 0.33µF   | 0.08                    |
| 0.5µF  | 0.12                    |
| 0.8µF  | 0.34                    |
| 1.0µF  | 0.44                    |
| 1.5µF  | 0.59                    |
| 2.0µF  | 0.75                    |
| 3.0µF  | 0.90                    |
| 12V  | 0                       |
| 10V  | 0.2                     |
| 8V   | 0.4                     |
| 6V   | 0.6                     |
| 4V   | 0.8                     |
| 2V   | 1.0                     |
| 0V   | 20% greater than f.s.d. |

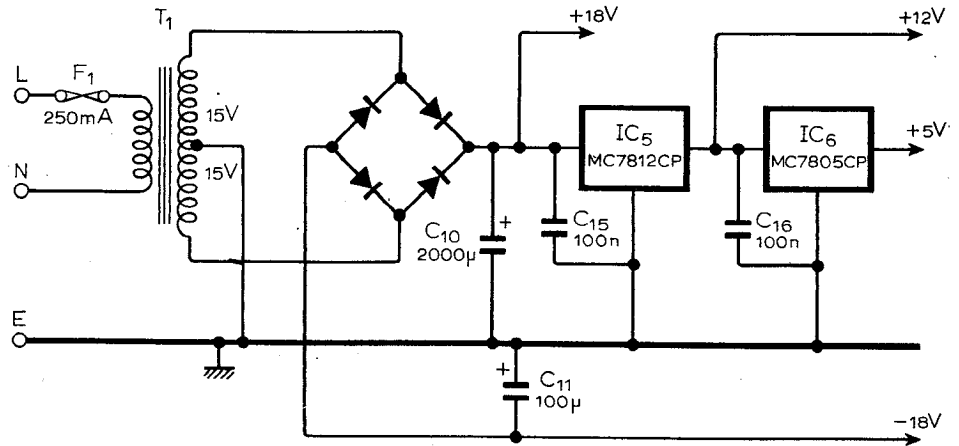

Fig.4. Power supply.

is important that this spike is applied only to a Schmitt trigger input to prevent oscillation when the input voltage lies between logic 1 and 0. The operational amplifier requires positive and negative supplies in order to operate on inputs that are very close to 0 or +12V. Current consumption of the amplifier is low, and the inherent ripple rejection is high so a simple power supply as shown in Fig. 4 is adequate.

**Construction & calibration**

Leads should be kept short and wherever possible separate. This is particularly important in the relatively high impedance wiring associated with the timing circuits of IC<sub>1</sub> and IC<sub>3</sub>. An efficient ground plane should be provided on the circuit board to keep the earth impedance as low as possible. Disc ceramic capacitors should be used to decouple the circuits at h.f. If the power supply leads are more than 25cm long sufficient l.f. decoupling must also be provided. The best solution is to mount the power supply regulators on the circuit board. If monolithic voltage regulators are used, it is advisable to decouple the input lead with a disc ceramic capacitor to ensure stability.

Calibration of the meter movement is achieved by adjusting the preset potentiometer on IC<sub>3</sub> with a capacitor of known value on test. Calibration for other values and ranges should then be correct. Resistor R<sub>19</sub> is used for scaling the voltmeter circuit. The prototype uses a 1mA meter movement and consequently a 10kΩ resistor is required to provide a 10V f.s.d. range. The tester is not really suitable for capacitors with voltage ratings of less than 10V. Lower voltage components may be tested provided that no attempt is made to reform them from the internal 12V current-limited supply, and the range selected for testing ensures that the terminal voltage is less than the capacitor peak voltage rating. The meter scale

can be marked with the capacitor terminal voltage corresponding to the capacitance value of this purpose. The table shows the prototype meter calibration figures.

Electrolytic capacitors vary in value according to the applied voltage, and when a capacitor is severely under-rated, the nominal capacitance is reduced. This must be borne in mind when relatively high voltage capacitors are tested. Because the tester measures voltage from 0V, the capacitor voltage will decay upwards. Some capacitors, always faulty, exhibit a fall of meter reading. This effect is similar to a c.r.t. regaining the e.h.t. potential, after switch-off, due to the physical properties of the glass dielectric.

**P.C.Bs**

A glass fibre printed circuit board which accommodates board mounted switches will be available for £3.50 inclusive from M. R. Sagin at 23 Keyes Road, London NW2.

We understand that Circuit Services, 36 Hallows Crescent, S. Oxhey, Herts, will be offering a set of components for this design.

**Correction**

In the article "Metal detector," published in the April issue, the values of R<sub>3</sub> and R<sub>7</sub> were printed incorrectly in the parts list. The correct values are 4.7kΩ as shown in the circuit diagram.

*Readers of the April issue may have been fooled by Part 2 of the article entitled Power Semiconductors — so were we; it should have read Part 1.*

## Surround sound decoders — 5

# Variomatrix adaptor for System 45J and Matrix H

## Phase shift circuit allows Variomatrix to decode Matrix H and System 45J

by Michael A. Gerzon, M.A., *Mathematical Institute, Oxford.*

Many hi-fi enthusiasts have Sansui Variomatrix decoders, and the present article describes an adaptor suitable for converting the Variomatrix for decoding signals encoded via the NRDC System 45J or BBC Matrix H systems. While such a decoder cannot by psycho-acoustically optimal, it does permit existing owners to extend the usefulness of their equipment.

The adaptor essentially does the job of converting the 45J or Matrix H signals into a form which the Variomatrix is designed to handle, i.e. into signals which are good approximations of Regular Matrix signals. The optimum method of conversion is slightly different for these two systems, but fortunately involves in both cases the use of a  $58^\circ$  phase-shift network, so that the circuit is kept fairly simple despite its two-fold function.

Essentially, the Matrix H adaptor consists of a  $58^\circ$  phase lead put into the right-channel signal relative to the left channel. The System 45J adaptor adds to this a  $-15\text{dB}$  blend circuit at the outputs of the phase shifters. The six pole phase shifter described gives a  $58^\circ$

shift with  $\pm 4^\circ$  error over the frequency range 44Hz to 17kHz if precision components are used, and so is suitable for use even with a studio-quality Variomatrix. In practice for domestic applications, 5% tolerance components may be used, although the use of 2% resistors will give better results.

The input circuit of the adaptor is shown in Fig. 1. Depending on the quality desired, the operational amplifiers may be 741 types or special audio types. The circuit is designed to offer a fairly high and resistive input impedance (18k or 14k depending on switch position), and gives approximately unity overall gain in all modes. The mode switch offers three positions: normal (i.e. conventional use for stereo and Regular Matrix), Matrix H, and System 45J.

An odd feature of the way the adaptor is connected is that (except in normal

mode) all left input signals are fed to the inputs labelled right on the Variomatrix, and vice-versa as shown in Fig. 1. Similarly, all outputs labelled left on the Variomatrix are connected to the corresponding right quadraphonic inputs on the preamplifier, and vice-versa. The reason for the switching shown is to ensure that the left/right interchanging of the Variomatrix inputs and outputs does not occur in the normal switch position, and for this reason, the mode switch is six-pole three-way. Also shown in Fig. 2 is a  $+2\text{dB}$  gain for the back channel outputs in the System 45J mode only; such a  $+2\text{dB}$  gain is necessary for best results. However, constructors may omit these gains from the circuit provided that the front/rear balance control of their system is adjusted to give this  $+2\text{dB}$  rear gain when decoding System 45J.

Owners of Sansui equipment in which the Variomatrix is integrated with the preamplifier and amplifier may not always find it convenient to use the output switching circuitry of Fig. 2, since this would involve breaking into the equipment. For such users, we

Fig. 1. Circuit of pre-Variomatrix adaptor. For best results, components should be 2% tolerance, though 5% should be acceptable.

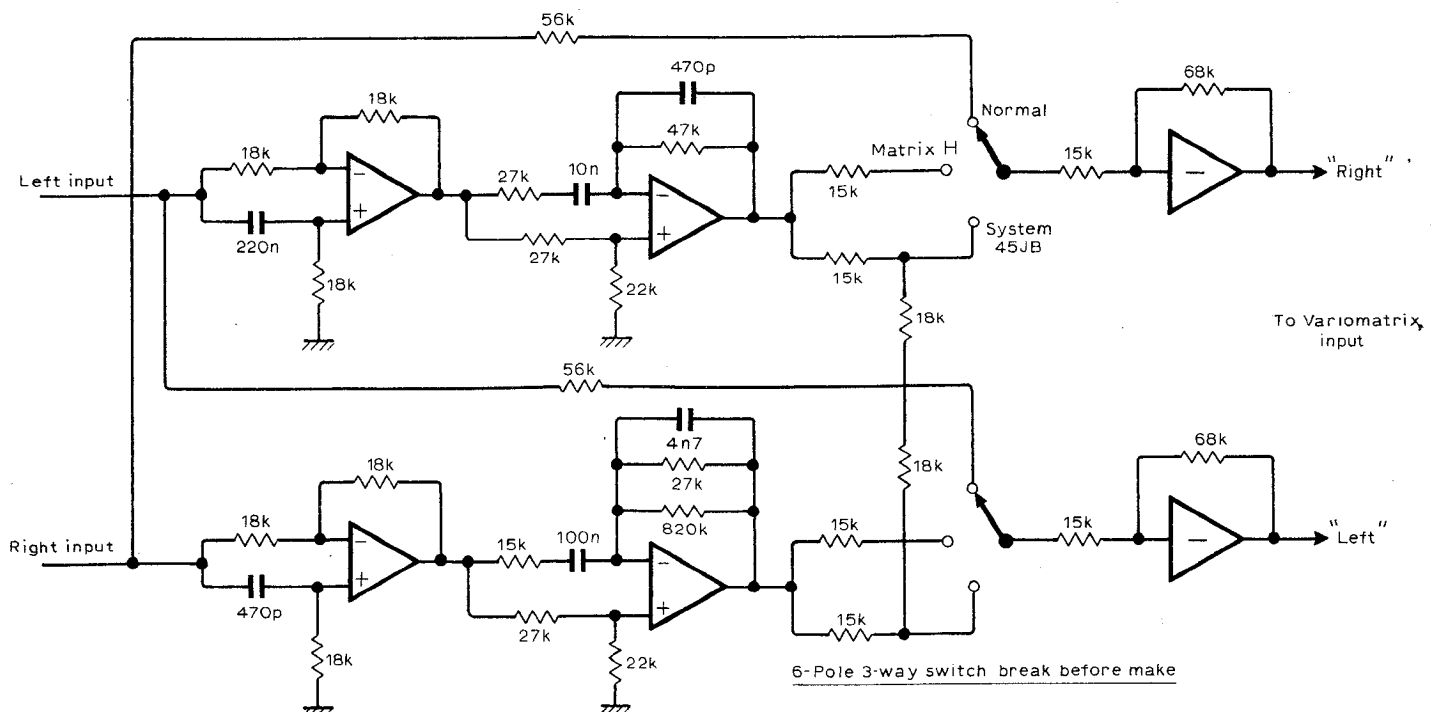

Fig. 2. Post-Variomatrix circuit, includes rear channel switched gain compensation. Resisting 5 or 10% tolerance.

suggest that they use the circuit of Fig. 1, for example in the tape monitoring circuit, but with the following modifications.

Connect the top output of Fig. 1 to the left Variomatrix input (and not the right), and the bottom output of Fig. 1 to the right Variomatrix input (and not the left), and

Feed the two 56kΩ resistors connected to the normal switch position from the left input for the top switch of Fig. 1, and the right input for the bottom switch of Fig. 1.

When used in this way, no left/right interchanging is used, and the switch need only be two-pole three-way. This method of use does not handle "interior encoded" sounds quite so well, but still generally works. For best results with System 45J with this simplified method of use, the front/rear balance control should be set to give +2dB gain to the rear speakers.

The Matrix H switch position will decode existing BMX discs (e.g. the UD-4 discs of Nippon Columbia) with reasonably accurate results, so that in practice the circuit allows decoding of Regular Matrix, Matrix H, System 45J and BMX.

As the author is connected with the NRDC Ambisonic project, in order to avoid possible misunderstandings it is pointed out that the use of a Variomatrix with the adaptor described will **not** give proper NRDC Ambisonic decoding

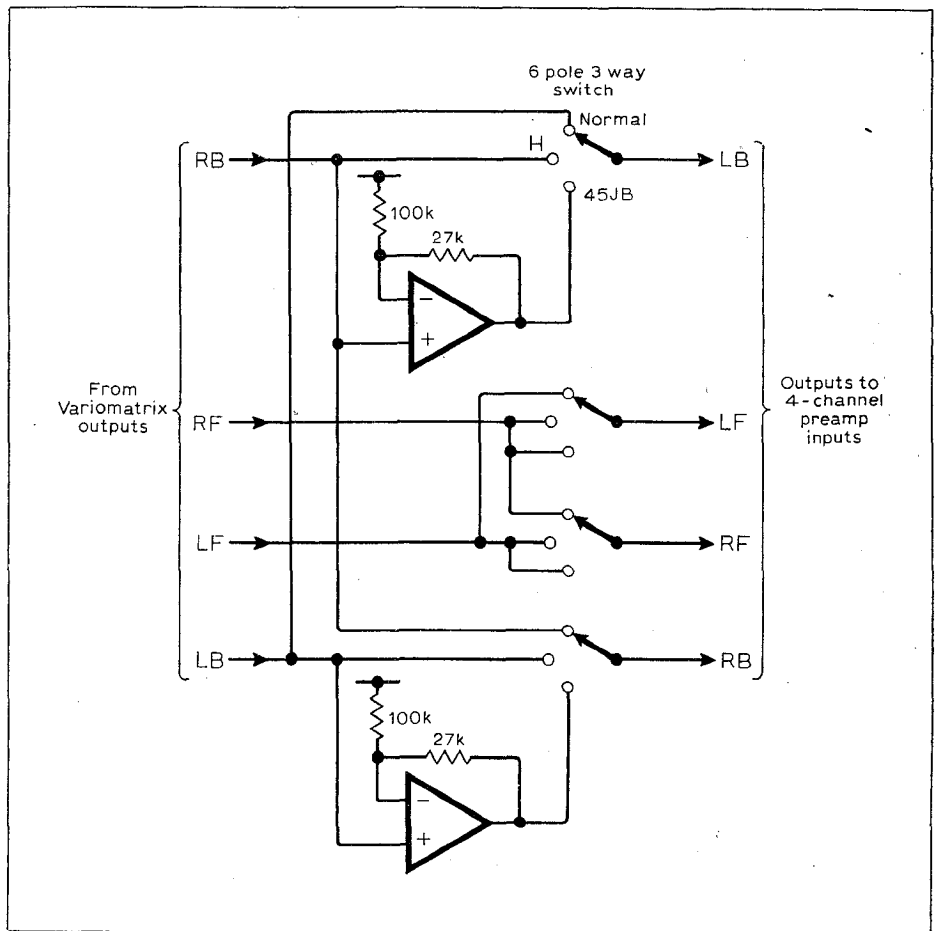

with optimal psychoacoustic results, but is merely a means of enabling Variomatrix owners to use their existing equipment with some of the newer systems.

Also, the method of using the Variomatrix described is solely the author's responsibility, and neither Sansui Elec-

tric Company Ltd nor the BBC would necessarily regard such use as being according to their own recommendations.

The BBC have applied for a patent (34839/74) on the use of a Variomatrix decoder with a prior phase shifting circuit of about 60°. — Ed.

# HF predictions

Ionospheric conditions this month are about the same as they were in 1974 except that solar activity then was decreasing and now is increasing.

Magnetic disturbance is likely to occur over the whole of the second half of the month.

Sporadic E propagation is forecast on at least 20% of the days and should modify the FOT curves as follows: Hong Kong peaking to 21MHz at 10 GMT; Johannesburg rising to 22MHz at 09 GMT and remaining so until 15GMT; Montreal maintaining 10MHz from 23 through 08 GMT; Buenos Aires dip between 06 and 10 GMT smoothed out.

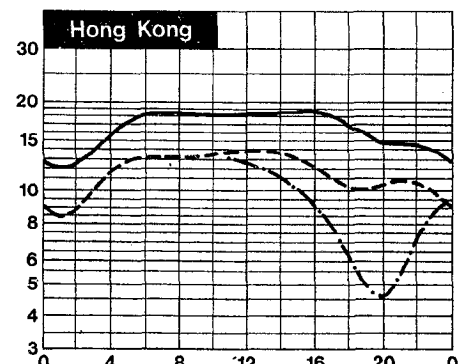
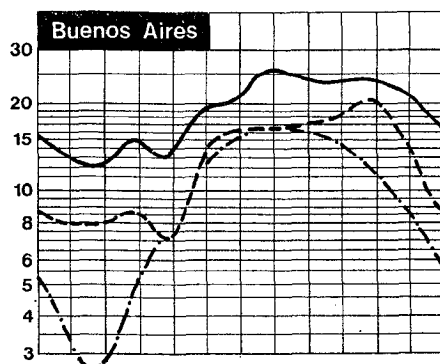
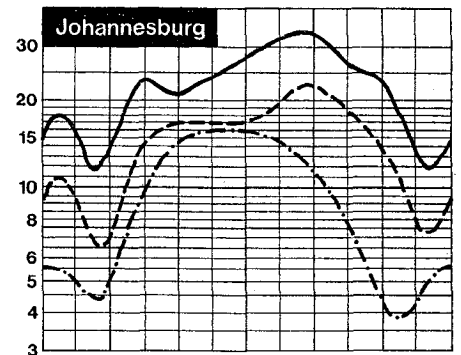
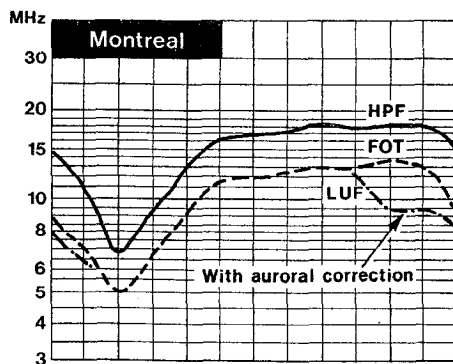

Time scale on right is 2-hour divisions GMT, midnight to midnight.



# Logic design — 4

## Causes of malfunction in event-driven circuits

by B. Holdsworth\* and D. Zissost†

\*Chelsea College, University of London †Department of Computing Science, University of Calgary, Canada.

In the last article, the procedure needed for the design of event-driven logic circuits was discussed. This second half of that article goes on to describe the causes of misoperation in such circuits and concludes with some examples of design. It is unfortunate that some of the diagrams concerned with this half of the article appeared in the first half — for this, we apologise.

**Races between primary signals.** The circuit shown in Fig. 11 is required to operate three lamps  $L_1$ ,  $L_2$ , and  $L_3$ , according to the following specifications.

(1) Lamp  $L_1$  is to turn-on when both X and Y are operated, but only if switch X is operated before switch Y.

(2) Lamp  $L_2$  is to turn-on when both input switches are operated simultaneously.

(3) Lamp  $L_3$  is to turn-on when both X and Y are operated, but only if switch Y is operated first.

In practice, a logic circuit responds with different speeds to changes in the input signals. Hence the response time of the circuit to a change in the input signal X must be assumed to be different from the response time to a change in Y. As a consequence the circuit, instead of assuming state  $S_3$  on leaving state  $S_0$ , either assumes state  $S_2$ , if the circuit responds to the change in X first, or alternatively it enters state  $S_5$ , if the circuit responds to a change in Y first. In both cases the circuit operation is not according to specification.

Since there is no remedy to this problem the circuit constraint applied is that only one input signal is allowed to change at a time.

**Races between secondary signals.** In the internal state diagram shown in Fig. 12(a), the coding of the internal states is such that circuit transitions  $S_0$  to  $S_1$  and  $S_2$  to  $S_3$  involve the change of more than one secondary signal. In practice because of variations in the response times of the two secondary signals to a change in the input signal X from 0 to 1, either A or B will change first.

Assuming that A changes first the circuit, when it leaves  $S_0$ , first enters  $S_2$ ,

From state  $S_2$ , because  $X=1$ , the circuit assumes state  $S_3$  instead of  $S_1$ , and this a stable state for  $X=1$ . This is clearly incorrect operation of the circuit. Obviously a similar analysis of the circuit operation can be performed for the case when B changes faster than A.

The solution to this problem is to ensure that each circuit transition involves the change of one secondary signal only and a race-free assignment of the state variables should be used as described earlier in this article and as shown in Fig. 12(b).

**Races between primary and secondary signals.** A circuit implementation of Fig. 12(b) is shown in block schematic form in Fig. 13. The letters a and b are

assigned to the two sections of the circuit which generate the secondary signals A and B.

Consider the transition from  $S_0$  to  $S_1$  in Fig. 12(b). This transition will take place in the time  $t_s$ , which it takes to turn-on the secondary signal B. It will also be assumed that the time taken to invert the primary signal X is  $t_p$ . If  $t_p > t_s$  the following sequence of events will take place.

(1) At time  $t_s$ , B changes to 1 and the circuit assumes state  $S_1$ .

(2) Since  $t_p > t_s$ ,  $\bar{X}=1$ , and the condition for turning A on exists.

(3) A turns on causing the circuit to move to state  $S_2$ .

(4) On assuming state  $S_2$ , the circuit

Fig. 11. Three-lamp circuit and its state diagram.

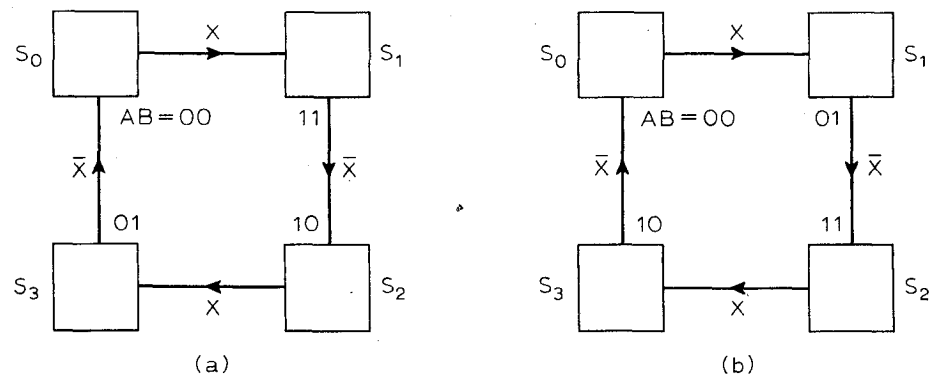
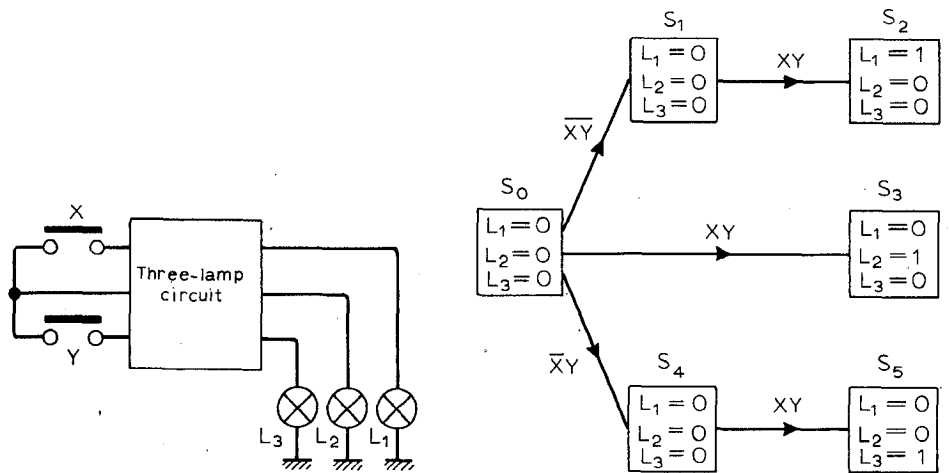

Fig. 12. Elimination of races between secondary signals.

moves to state  $S_3$ , since  $X=1$ .

If  $t_p < t_s$  on assuming state  $S_1$  the input signal to section a has already changed, i.e.  $\bar{X}=0$ , and the circuit remains in state  $S_1$ .

Unlike the previous two cases, elimination of races between primary and secondary signals cannot be achieved, since a change in a primary signal initiates a change in a secondary signal. Therefore to avoid circuit misoperation it is necessary to ensure that  $t_p \leq t_s$ . It follows that incorrect circuit behaviour will not occur if the maximum delay associated with a primary signal  $t_{pmax}$ , is less than the minimum delay associated with a secondary signal  $t_{smin}$ .

Hence

$$\frac{t_{pmax}}{t_{smin}} \leq 1$$

**The 33 1/3% property**

The sequential circuits designed with the aid of the sequential equations are hazard-free when implemented with gates whose maximum speed tolerance is  $\pm 33\frac{1}{3}\%$ . The justification for this statement is as follows.

The maximum delay by which a primary signal in primitive sequential circuits can be delayed is one gate delay,  $t_g$ , when it has to be inverted. Allowing

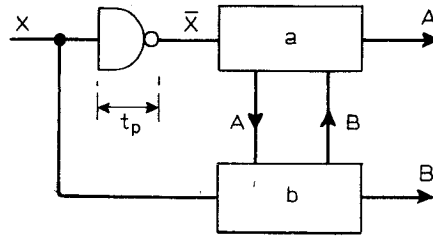

Fig. 13. Races between primary and secondary signals.

$x\%$  variation due to production spread, loading etc.  $t_{pmax} = t_g(1+x)$ .

The minimum delay associated with a secondary signal is  $2t_g$ , since at least two levels of switching are involved, as an examination of the NAND sequential equation  $Q = S + \bar{R}Q$  will show. Allowing  $x\%$  variation,  $t_{smin} = 2t_g(1-x)$ .

Substituting these values in the equation developed in the last section gives  $t_g(1+x)/2t_g(1-x) \leq 1$  for correct circuit behaviour. The reader should observe that this property is valid for

Fig. 14. Function to be realized in (a) and its state diagram is at (b), while the state table is shown in (c) and in merged form at (d). Initial state diagram based on (d) is shown at (e), and realization of the circuit is (f). Output of r.h. circuit is a.

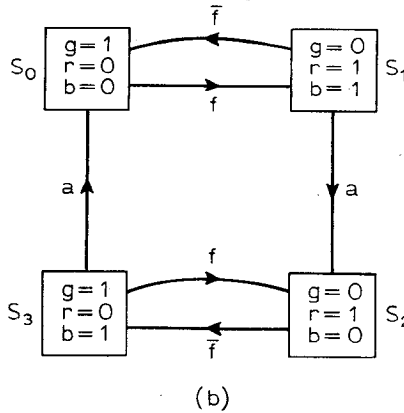
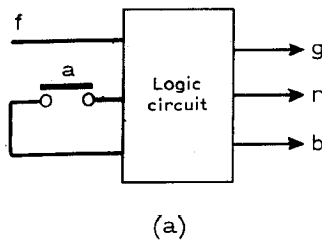

| fa             | 00                                    | 01                             | 11                             | 10                         |
|----------------|---------------------------------------|--------------------------------|--------------------------------|----------------------------|
| S <sub>0</sub> | $\textcircled{S_0}$<br>g=1 r=0<br>b=0 | $\textcircled{S_0}$<br>100     | $\textcircled{S_1 S_2}$<br>010 | $\textcircled{S_1}$<br>011 |
| S <sub>1</sub> | $\textcircled{S_0}$<br>100            | $\textcircled{S_0}$<br>100     | $\textcircled{S_2}$<br>010     | $\textcircled{S_1}$<br>011 |
| S <sub>2</sub> | $\textcircled{S_3}$<br>101            | $\textcircled{S_3 S_0}$<br>100 | $\textcircled{S_2}$<br>010     | $\textcircled{S_2}$<br>010 |
| S <sub>3</sub> | $\textcircled{S_3}$<br>101            | $\textcircled{S_0}$<br>100     | $\textcircled{S_2}$<br>010     | $\textcircled{S_2}$<br>010 |

(c)

| fa              | 00                                       | 01                            | 11                            | 10                            |
|-----------------|--|-------------------------------|-------------------------------|-------------------------------|
| S <sub>01</sub> | $\textcircled{S_{01}}$<br>g=1 r=0<br>b=0 | $\textcircled{S_{01}}$<br>100 | $\textcircled{S_{23}}$<br>010 | $\textcircled{S_{01}}$<br>011 |
| S <sub>23</sub> | $\textcircled{S_{23}}$<br>101            | $\textcircled{S_{01}}$<br>100 | $\textcircled{S_{23}}$<br>010 | $\textcircled{S_{23}}$<br>010 |

(d)

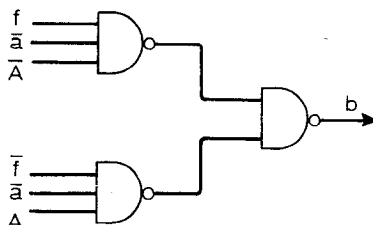
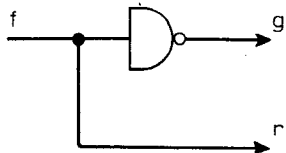
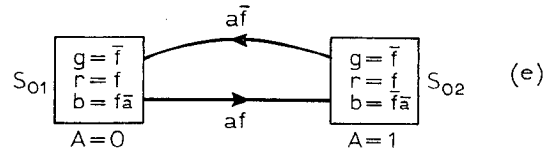

(f)

circuits in which the sequential equations are implemented in their primitive form. Algebraic manipulation of the sequential equations will lead to a modification of the relative delays of the primary and secondary signals and therefore invalidate the 33 1/3% property. Hence, processing of the sequential equations is not advised.

**Design steps**

**Step 1.** Draw a block diagram showing the available input signals and the required output signals.

**Step 2.** Draw a state diagram describing the internal performance of the circuit.

**Step 3.** This step is optional and can be omitted. Its purpose is to provide the designer with a means of reducing the number of internal states obtained in Step 2, if such a reduction is possible or desirable.

**Step 4.** With the aid of a race-free diagram if necessary, each internal state is given a unique code. From the coded state diagram the turn-on and turn-off sets for the secondary signals are obtained and these are used to derive the primitive sequential equations. Expressions are also obtained for the output signals. The implementation of these equations is the required circuit.

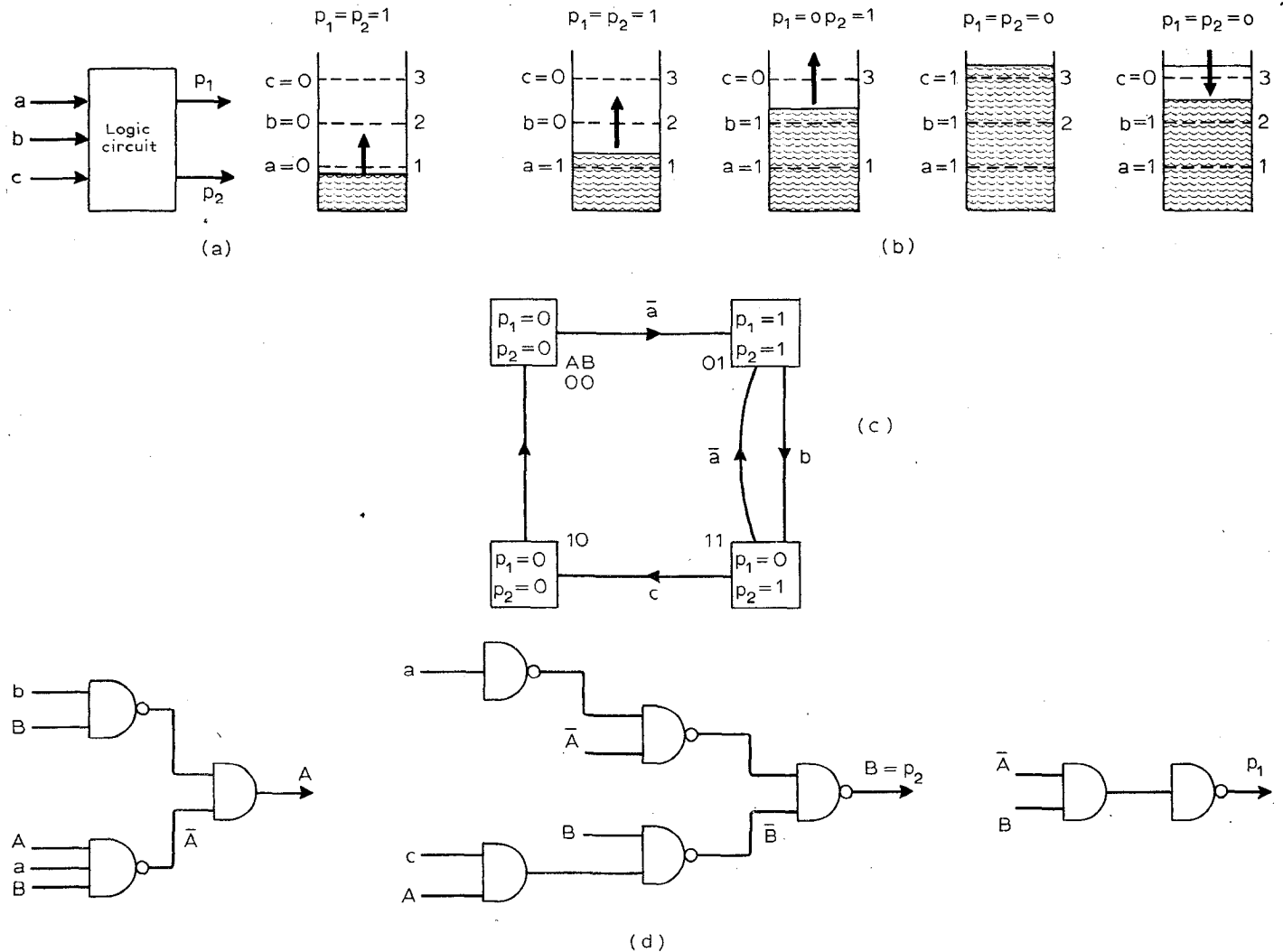

The design procedure will now be applied to the solution of two problems.

**Example 1**

Design a fault detector with the following terminal characteristics. The appearance of a fault signal *f* activates an alarm bell, turns a green light off and a red light on. The operator turns off the bell by pressing an acknowledge button *a*. When the fault is cleared, the red light turns off, the green light turns on and the bell is reactivated to attract the operator's attention. The bell is turned off when the operator presses the acknowledge button. Should the fault clear before the operator has responded, the circuit is to reset. Also if a fault reappears before the operator has responded the green light turns off, the red light turns on and the bell turns off.

**Step 1.** See Figs. 15(a) and (b)

**Step 2.** A suitable state diagram is shown in Fig. 15(c).

**Step 3.** The state table corresponding to Fig. 14(b) is shown in Fig. 14(c). Applying Caldwell's merging rules to the state table in Fig. 14(c), states *S*<sub>0</sub> and *S*<sub>1</sub> can be merged to form state *S*<sub>01</sub> and states *S*<sub>2</sub> and *S*<sub>3</sub> can be merged to form state *S*<sub>23</sub>. The reduced state table is shown in Fig. 14(d).

The internal state diagram based on the reduced state table is shown in Fig. 14(e).

**Step 4.** By direct reference to Fig. 14(e)

Fig. 15. Function required by Example 2 is seen in (a) and (b). State diagram in (c) provides turn-on and turn-off sets for use in NAND realization. Circuit is shown in (d).

the turn-on and turn-off sets are: Turn-on set of *A* = *a**f*. Turn-off set of *A* = *a* $\bar{f}$ . Therefore the NAND circuit equation for *A* is

$$A = af + Aa\bar{f}$$

$$A = af + A(\bar{a} + f)$$

$$g = \bar{f}$$

$$r = f$$

$$b = f\bar{A}\bar{a} + \bar{f}A\bar{a}$$

The corresponding circuit is shown in Fig. 14(f).

**Example 2**

Water is pumped into a water tower by two pumps *p*<sub>1</sub> and *p*<sub>2</sub>, where *p*<sub>1</sub> is an auxiliary pump used for boosting purposes. Both pumps are to turn on when the water goes below level 1 and are to remain on until the water reaches level 2, when pump *p*<sub>1</sub> turns off and remains off until the water is below level 1 again. Pump *p*<sub>2</sub> remains on until level 3 is reached when it also turns off and remains off until the water falls below level 1 again.

Level sensors are used to provide level detection signals as follows:

Signal *a* = 1 when the water is at or

above level 1, otherwise *a* = 0. Signal *b* = 1 when the water is at or above level 2, otherwise *b* = 0. Signal *c* = 1 when the water is at or above level 3, otherwise *c* = 0.

Develop a sequential logic circuit to control the pumps *p*<sub>1</sub> and *p*<sub>2</sub> according to the specification given above.

**Step 1.** See Figs. 15(a) and (b)

**Step 2.** A suitable state diagram is shown in Fig. 15(c).

**Step 3.** It is left as an exercise for the reader to draw the state table and examine the possibility of state reduction.

**Step 4.** By direct reference to Fig. 15(c) the turn-on and turn-off sets are:

$$\text{Turn-on set of } A = bB$$

$$\text{Turn-off set of } A = \bar{B} + \bar{a}B = \bar{B} + \bar{a}$$

$$\text{Turn-on set of } B = \bar{a}\bar{A}$$

$$\text{Turn-off set of } B = cA$$

Therefore the NAND circuit equations are:

$$A = bB + A(\bar{B} + \bar{a})$$

$$= bB + Aa\bar{B}$$

$$B = \bar{a}\bar{A} + (c + \bar{A})B$$

$$p_1 = \bar{A}B$$

$$p_2 = \bar{A}B + AB$$

$$= B$$

The corresponding circuit is shown in Fig. 15(d).

Article 5 of the series will be a discussion of clock-driven circuits.

# Viewdata

## 4 — The Viewdata terminal in more detail

by S. Fedida, B.Sc.(Eng.), M.Sc., F.I.E.E., A.C.G.I., *Post Office Research Centre*

A Viewdata decoder may be considered as being made up of six parts, as shown from left to right in Fig 1(a): a line isolation unit; a modem; a keypad; an input processor; a store (possibly r.a.m.); and an output processor. Indeed the breakdown of facilities is very similar to that of teletext, shown in Fig. 1(b). This diagram also indicates that, apart from additional minor interconnections, parts common to Viewdata and teletext are the store and output processor. These are substantial components and therefore combined Viewdata/teletext receivers show important savings over two separate decoders for the two services. This is a slightly over-simplified picture but the situation will be clarified later.

Note however, an important difference. The input circuits in Viewdata, up to and including the store are bi-directional, thus highlighting the interactive nature of the system. On teletext the input circuits are one way only.

### Line transmission

The transmission code used over the telephone line between the Viewdata terminal and the computer is at present 8-bit, 10-unit asynchronous (or start stop), as shown in Fig. 2. Each character

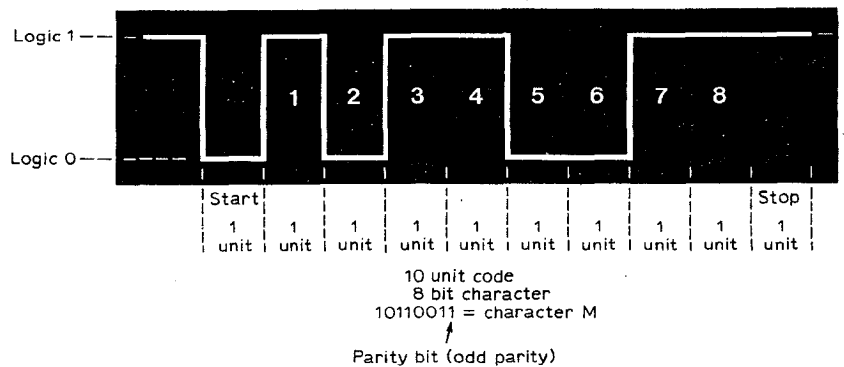

Fig. 2. Transmission code used between a Viewdata terminal and the computer is an 8-bit, 10-unit asynchronous code.

consists of an 8-bit code, the first 7 bits containing the information while the 8th bit is a parity bit. Preceding each character is a start bit, with a stop bit terminating the character. The character illustrated in Fig. 2 is M, with odd parity. A 10-unit asynchronous system

was chosen for simplicity. It is clearly not as efficient as a synchronous transmission mode, in which characters follow each other without the intervention of start and stop bits, but it is simpler to implement and is currently used by many time-sharing computer systems.

In order to transmit this code over a telephone line, a modem (modulator-demodulator) is required. Essentially this device modulates the code on to a voice frequency carrier, within the speech band, thus obviating the problems encountered with very low frequency transmission over the telephone network. The modem also enables the go and return transmission to take place

Fig. 1. Comparing the main sections of (a) a Viewdata decoder with (b) those of a teletext decoder

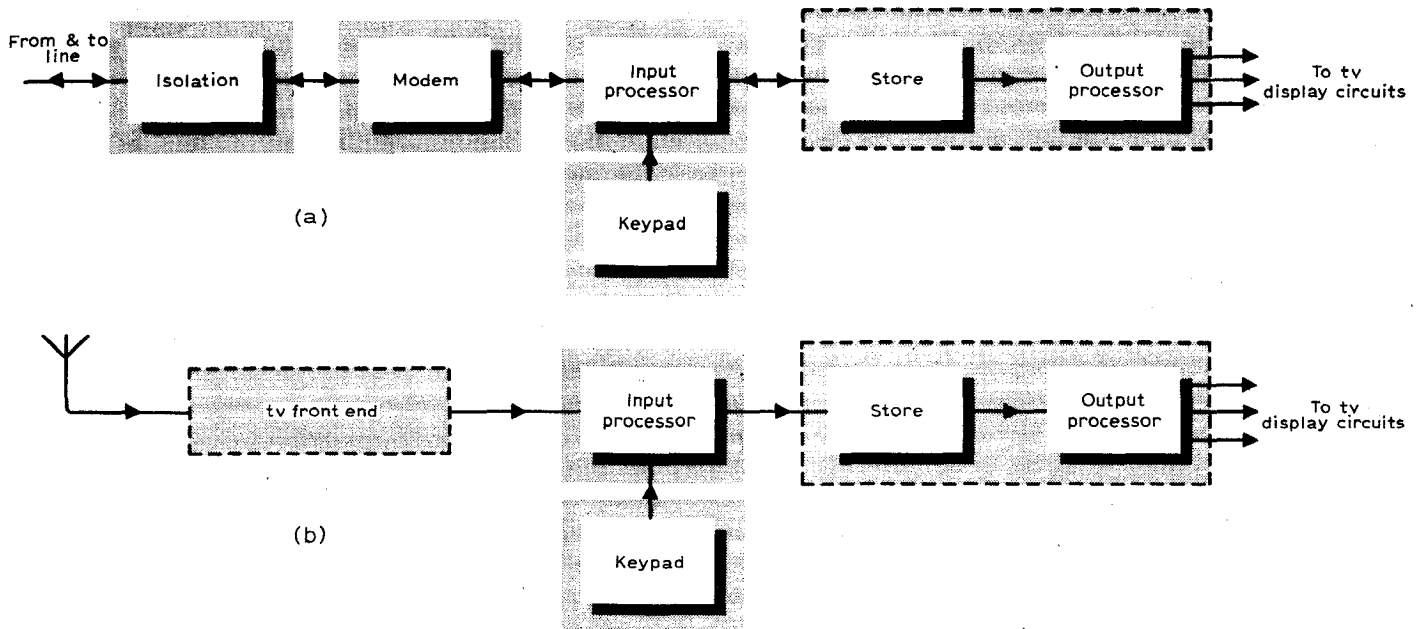



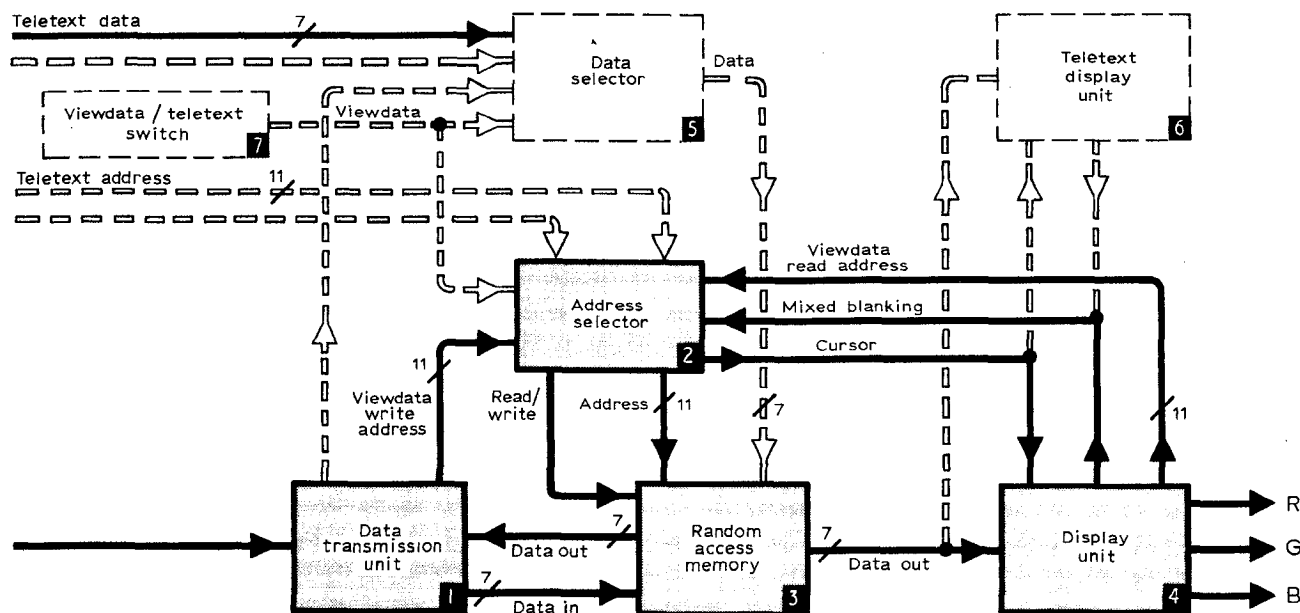

Fig. 3. Simplified block diagram of a Viewdata terminal, with adaptation to teletext shown in broken lines. The number and bar on certain connecting lines indicate that the line is carrying parallel information on that number of wires.

simultaneously over the two-wire telephone line.

Transmission rates selected for Viewdata during the present experimental phase are 1200 bits per second from computer to terminal and 75 bits per second in the reverse direction.

In the computer-to-terminal direction as high a transmission rate as possible is desirable in order to achieve a fast picture build-up. 1200 bits per second was chosen to fit in with a well tried and readily available modem. For the majority of Viewdata displays, consisting for example of mainly alphanumeric characters, the picture build-up is much faster than can be read by the user, and hence quite adequate from this point of view. Where, however, large uniform areas of graphics are displayed, the build-up may appear rather slow (the display shows repetitive information), and improvements to the build-up in this case may be obtained by using special means. But in general the additional complexity is not really worthwhile.

In the direction from terminal to computer the bit rate of 75 bits per second (7.5 characters per second) is quite adequate for hand keying.

The frequencies used in line transmission are as follows:

Forward channel: binary 1 = 390 Hz  
(from terminal to computer) binary 0 = 450 Hz

Return channel: binary 1 = 1300 Hz  
(from computer to terminal) binary 0 = 2100 Hz

When no data transmission is taking place on the line the terminal is transmitting continuously at 390Hz and the computer at 1300Hz. These tones are used in the modems at either end of the line to provide an indication of continuity, which as we shall see below is of some importance in the operation of the whole system.

When data is being transmitted the

carrier is frequency modulated (frequency shift keying), between the binary 1 and binary 0 frequencies, the change being smoothed out to give a gradual transition between the frequencies.

The transmission arrangement used at present is duplex, with "echoing" facilities provided from the computer to the terminal. In a duplex system transmission may take place in both directions at once over the telephone with no mutual interference (hence, of course, the choice of frequencies). Characters keyed at the terminal are first transmitted by the modem to the computer and displayed only when they are "echoed" back. This arrangement gives some important advantages. First, it provides a measure of error detection, the user being aware of any corruption in transmission, errors in the computer or mis-keying errors. Secondly, duplex working also increases the user's confidence in the working of the system, as "echoed" characters provide a continuous indication that the whole system is in satisfactory order.

"Echoing" from the terminal to the computer is not necessary. A parity check is sufficient to provide for the detection of the majority of errors, the computer usually responding in these cases by requesting a repetition of the instruction. The computer also monitors continuously the terminal carrier, thus ensuring that a line break is noted as soon as it occurs. This avoids the possibility of the user being incorrectly charged for using the system after the occurrence of a line interruption.

### Experimental Viewdata terminal

The experimental Viewdata terminal at present in use is best introduced in two parts: (a) the data transmission unit, which deals with the Viewdata signal between the telephone line and the internal store, and (2) the display unit, which deals with the Viewdata signal between the store and display device (the c.r.t. of a television set). As explained earlier, much of the display part is common with teletext.

A typical arrangement of a Viewdata terminal is shown in Fig. 3. There are four major units as follows: the data transmission unit (1); the address selector (2); the random access memory (3); and the display unit (4).

The address selector (2) is the only unit which interconnects the input and output processors, essentially for the purpose of preventing mutual interference. Unlike the situation in teletext data is received at random times from the telephone line, completely unsynchronized with the operation of the display. It is therefore necessary to organise the access to the memory for reading out and display on the one hand, and writing-in incoming characters on the other hand, without cross-interference. This function is carried out by the address selector. The write address generated in the data transmission unit (1) and the read address generated in the display unit (4) are both available at the address selector.

A mixed blanking waveform, also generated in the display unit, indicates the times at which characters are required to be extracted from the memory for display purposes essentially during 40 microseconds of every line period, excluding blank lines at the top and bottom margins of the display. During these times incoming characters are made to dwell a little longer in an input character buffer in the data transmission unit and the address supplied to the memory is the read address. At other times the write address is

switched to the memory. The address selector also notes the coincidence between the read address and the write address when it delivers a pulse to the display unit to initiate the generation of the cursor display (see Part 3).

Shown also in Fig. 3 in broken lines, are the units required for interfacing Viewdata with teletext. In a receiver already fitted with a teletext decoder, one additional unit is required: the data selector (5), while the Viewdata display unit may be dispensed with and the teletext display unit (6) used instead. The connections required are shown also as broken lines. A Viewdata/teletext switch unit (7) is also shown. This sets data and address selectors to Viewdata or teletext as required.

In the teletext mode the address and data selectors switch the memory to the teletext input circuits, while in the Viewdata mode the memory is available to Viewdata. The read address, however, is now provided by the teletext address, which scans the memory during the mixed blanking period.

**Data transmission unit**

The data transmission unit is shown in more detail in Fig. 4. This consists of a line isolator (1) and a modem (2, 3, 4), the last-mentioned including a modulator (4) which transforms the outgoing data stream to a voice frequency signal, a demodulator (3) which accepts a voice frequency signal from line and extracts the data stream from it, and a control circuit (2) which switches the connection of the telephone line to the telephone receiver or to the modem.

The transmission control unit (6), which is synchronized by the clock unit (5), accepts the demodulated data in serial form, checks character parity and

offers assembled characters to the control codes decoder (9). It also triggers the operation of the timing unit (10) which generates the necessary waveforms used throughout the data transmission unit. The control codes decoder recognises the special control characters used in Viewdata, initiates the corresponding control functions and enables the memory (8) to store the appropriate characters. It also controls the memory address unit (11), which maintains a record of the addresses at which incoming characters are to be stored and instructs the terminal identifier (12), to generate the automatic identification code in reply to an enquiry signal received from the Viewdata computer.

The transmission control unit, the timing unit and the page transmission unit (7) together control the transmission of a complete page from the terminal to the computer. The keypad unit (13) generates and encodes the terminal responses and outputs these direct to the modem, for transmission to the computer.

The data transmission unit operates in two different modes: reception mode and transmission mode.

**Reception of Viewdata signals**

**Isolator and modem.** The Viewdata signal enters the terminal from the telephone line, after passing through the isolator. This may consist simply of

two pairs of opposite polarity gas discharge tubes, each pair connecting one of the telephone wires to earth. It ensures that voltages originating from the terminal are limited to safe values before entering the telephone network. It also contains fuses, in series with each telephone wire and on either side of the gas discharge tubes, to limit the current flowing. The gas discharge tubes have a striking voltage of about 150V, to avoid breakdown in the presence of ringing tones originating in the telephone line.

Following the isolator is the modem control unit, which contains a relay operated by the "data" button on the telephone. When this button is depressed it switches the telephone line from the telephone receiver to a hybrid transformer within the control unit. This separates the go and return channels connected to the modulator and demodulator respectively.

The incoming Viewdata signal is superimposed on an f.s.k. (frequency shift keying) carrier, binary 1 corresponding to a frequency of 1300Hz and binary 0 to a frequency of 2100Hz. The incoming carrier first goes through two stages of bandpass filtering to eliminate unwanted signals. After this it is frequency shifted by 10kHz, thus becoming a frequency modulated carrier centred on 11.7kHz with a deviation of  $\pm 400$ Hz, the modulation rate being 1200 per second. Frequency shifting the carrier by 10kHz makes the demodulation process much easier by virtue of increasing the number of carrier cycles per modulation cycle.

The incoming carrier is now applied to an unbalanced discriminator and a detector which extracts the data modulation. After filtering, amplification, squaring and level changing the data

Fig. 4. Data transmission unit at Viewdata terminal. The number and bar on certain connecting lines indicate that the line is carrying parallel information on that number of wires.

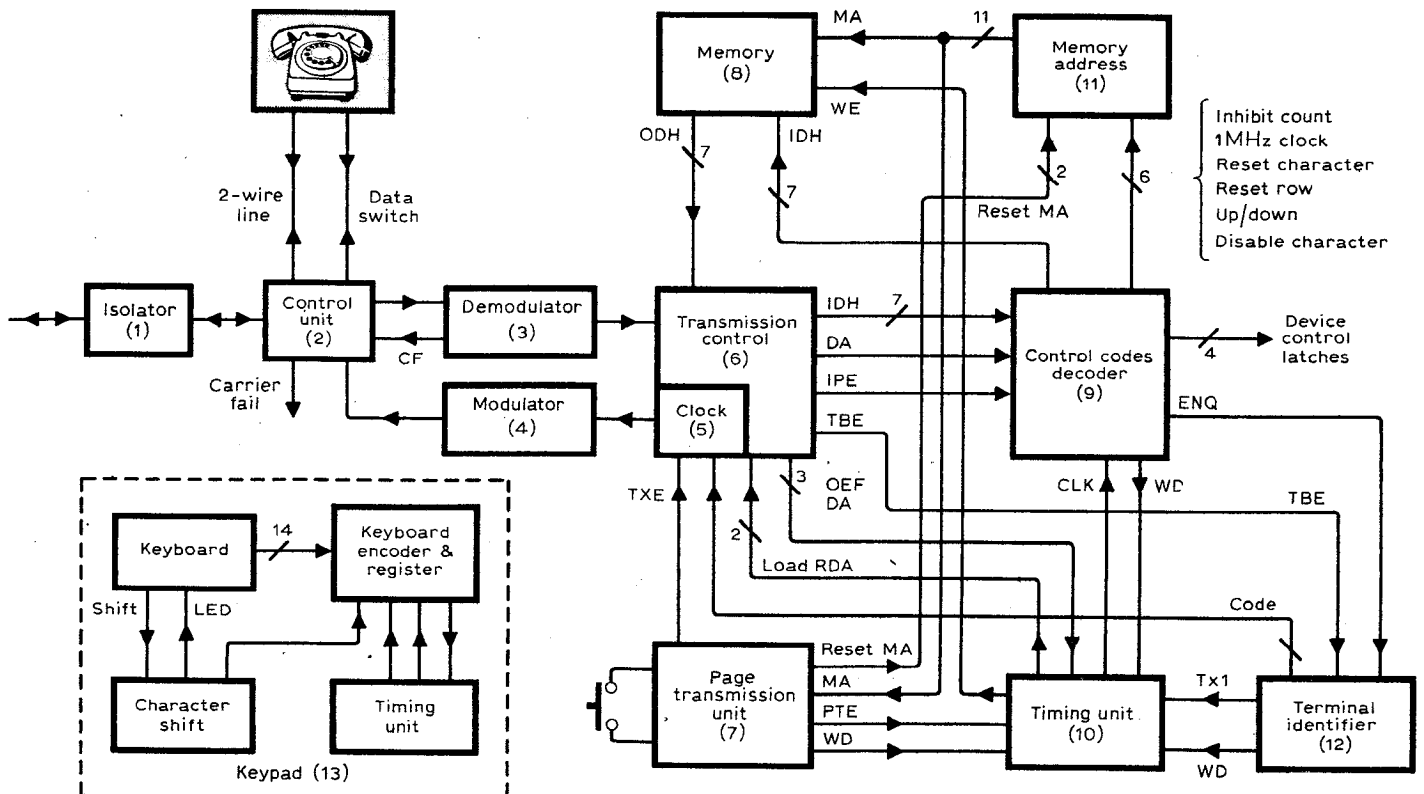

signal is fed out to the transmission control unit at a level of  $-6V$  for a frequency of 1300Hz (binary 1) and  $+6V$  for a frequency of 2100Hz (binary 0).

**The transmission control unit.** The transmission control unit accepts data in serial form and, using a sampling technique controlled by the clock generator, recognises the start and stop bits of each 10-bit character sequence, and stores each character in a temporary buffer. This completed, it signals the event to the timing unit, and control codes decoder, i.e. that a character has been received and is available for transfer at the input data highway in a 7-bit parallel form.

The transmission control unit also checks character parity and feeds out IPE (input parity error) to the control codes decoder if parity is found in error.

**The timing unit** provides a number of waveforms which control the storage of characters in the memory. On receipt of a "data available" signal from the transmission control unit, it transfers the intended location of the received character from memory address to memory, enables memory to accept the character, clocks memory address to the next character position and resets the transmission control unit to indicate that the character received has been accepted.

**The control codes decoder** accepts incoming characters from the input data highway, decodes the special control codes and initiates the appropriate actions as follows. The unit is "transparent" to all characters other than control codes, the former being applied direct to the memory to be stored therein.

The control codes decoder performs the following functions. On receipt of:

- (a) Non storing characters such as NUL, CR, LF, BS, FF, etc. it inhibits their storage in memory. (Write disable to timing unit.)

- (b) BS, it causes memory address to count down one character

- (c) VT, it causes memory address to count down one row.

- (d) CR, it causes memory address to be reset to character address of zero, leaving row address unchanged.

- (e) LF it causes memory address to count up one row.

- (f) FF it causes memory address to be reset to character address of zero and row address of zero. It also causes the complete content of memory to be erased by setting the code on the input data highway to "space" and entering this in the whole memory.

- (g) ESC it causes bit 7 of the received character to be changed from 1 to 0, before storage.

- (h) DC1 to DC4, it sets latches to control internal devices.

The control codes decoder, when receiving input parity error, substitutes

character 7/15 for the character received in error before it is entered in the memory. The implementation of memory and memory address may be either in the form of a random access memory or a series of shift registers. A r.a.m. appears to lend itself to a rather simpler logic circuit than a shift register memory and because of this has been assumed in the description of the terminal.

The memory address consists of characters and row counters which are controlled by the control codes decoder to indicate the address at which the next character is to be stored in the memory.

### Transmission of Viewdata signals

The transmission of Viewdata signals originates either from the keypad unit or the page transmission unit.

The keypad unit controls a keyboard connected in a cross-matrix of 5 columns and 9 rows, with a shift button, which together with the 45 keys, provide a maximum of 90 codes. The basic keypad with which most of the Viewdata facilities may be used provides only 12 codes, (0 to 9), \* and #, with additional optional codes for automatic calling.

In both cases the output of the keyboard matrix is applied to an encoder which generates codes appropriate to the keys selected, serializes the bit pattern thus obtained, adds parity, start and stop bits and applies the resulting data stream directly to the modulator, under the control of an internal timing unit which generates the appropriate clock signals. Characters fed out are not displayed on the screen until they have been "echoed" back by the computer.

The page transmission unit operates jointly with the transmission control unit and timing unit, and its operation is initiated manually by a push-button on the terminal. This causes the page transmission unit to reset memory address zero and enables transmission buffer empty (TBE) signal from the transmission control unit to start the timing unit (using the page transmission enables signal). It also inhibits the writing into memory, via write disable to timing unit.

On receipt of TBE, the timing unit generates a load signal to the transmission control unit which causes the latter to accept a character from memory, and to clock it out in serial form at 75 bits/second, complete with start, stop and parity bits, to the modulator. The timing unit also increases the memory address count by one. When a character has been discharged from the transmission control unit, the next transmission buffer empty signal recommences the above cycle on the next character. When 960 characters have been sent out, the page transmission unit notes the fact and resets the terminal to the quiescent state.

At the beginning of a Viewdata session the computer interrogates the

built-in terminal identifier. The control codes decoder initiates the operation of this unit, which sends out an identification code to the transmission control unit. This code is transmitted to the modulator, complete with start, stop and parity bits. The operation is similar to that of the page transmission unit except that the identification code is stored in the terminal identifier.

### Display unit

The display unit is shown in more detail in Fig 5. The function of the display unit is to generate line and frame synchronising signal for the television raster, to decode the special display control characters for colour and graphics and to generate alphanumeric and graphic symbols for display.

As mentioned earlier, the display unit is nearly identical to the corresponding part in the teletext decoder. The major differences are in the line and frame synchronising generators and in the provision for the cursor, which is not required in teletext. With respect to the line and frame synchronising pulses, these are essential in a Viewdata-only receiver since it is required that the Viewdata service should be available at all times and not just during tv broadcasting hours; thus it is not always possible to rely on the presence of tv line and frame sync to maintain the raster. The provision of line and frame sync pulses is also very useful in a combined Viewdata/teletext decoder, as indeed in a teletext-only decoder, since it is provided in teletext that viewers should be able to store a page of information transmitted during tv broadcasting hours and to view it later at their convenience, possible outside broadcasting hours.

The display unit consists of a sync generator and memory scanner (1), a display control codes decoder (2), an alphanumeric character generator (3), a graphics generator (4), a character rounding unit (5), and an output unit (6).

The sync generator and memory scanner generates line and frame synchronising pulses which are applied to the tv timebase generators, and row and character addresses which are applied to the r.a.m. via the address selector. The unit derives these waveforms from an 8MHz crystal controlled master oscillator followed by a chain of dividers. The extraction of characters from the memory and their display on the screen occurs at a rate of 1MHz, which is derived directly from the 8MHz clock by a divide-by-8 circuit, a further division by 64 providing the line synchronizing pulses. There is a certain amount of flexibility in the choice of master oscillator frequency; a lower frequency, say 7MHz or 6MHz, giving a wider character on the display, while not being quite so demanding on the width of the video passband. The width of individual characters may also be altered by adjusting the blank margins

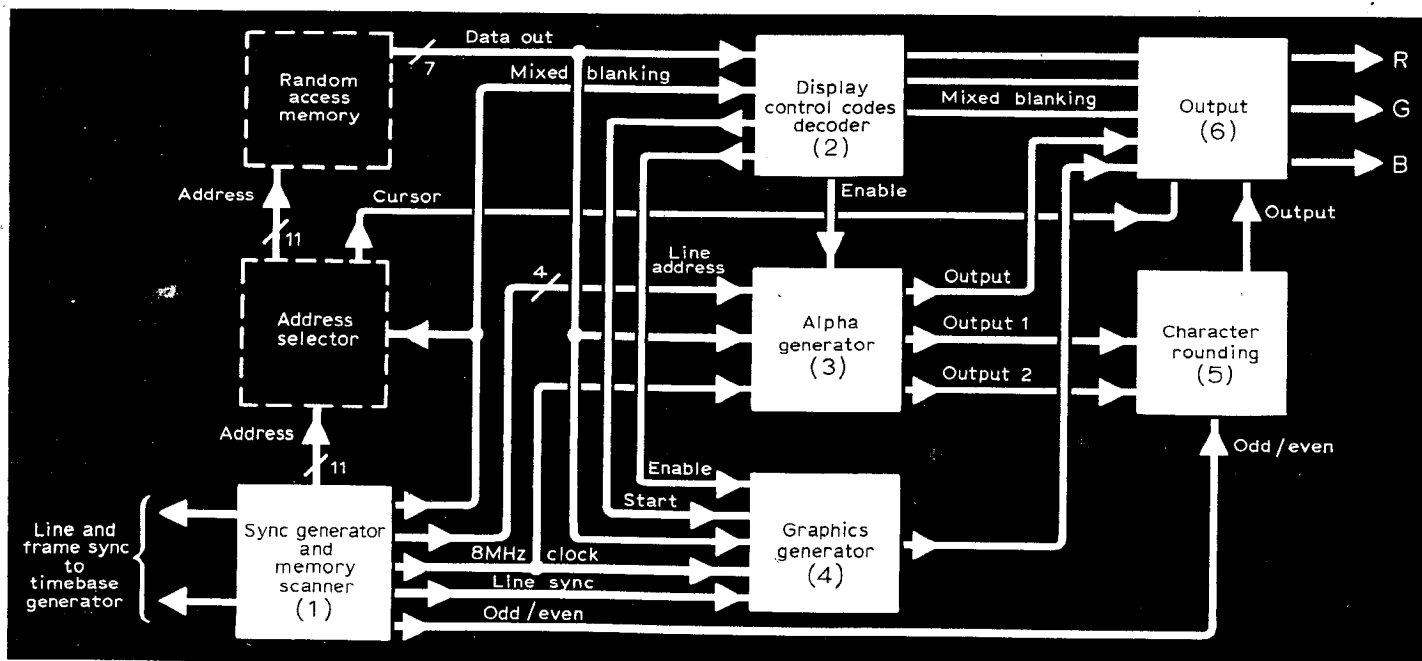

Fig. 5. Display unit at Viewdata terminal. The number and bar on certain connecting lines indicate that the line is carrying parallel information on that number of wires. Some commercial Viewdata tv receivers may have clock frequencies other than 8 MHz.

to the left and right of the page on display. The choice of 8MHz here is mainly of convenience to simplify the subsequent dividing circuits. The sync generator and memory scanner must also generate the mixed blanking waveform which provides the margins around the display area. Thus every  $1\mu\text{s}$  a read signal is applied to the r.a.m. which then feeds out the character stored at the location indicated by the row and character addresses generated by the unit.

The timing of the whole display unit must take into account delays occurring in the r.a.m. and in the alphanumeric character generators. These delays may be each of the order of 200 to 600 nanoseconds, depending on cost, the faster unit obviously being more expensive. Thus in order to take up these tolerances and allow the cheaper units to be used, a  $2\mu\text{s}$  delay is allowed for from the instant a character is requested from memory to the time it is displayed.

As in teletext, a row of characters consists of 10 television lines in each frame (20 lines counting the interlace), made up of 7 display lines and 3 spacing lines, each character space in the horizontal direction consisting of 8 dots, 5 display dots and 3 space dots, the dots occurring at the 8MHz rate.

As each character is fed out from the memory it is transferred to the display control codes decoder which is programmed to recognise the characters in columns 0 and 1 of Fig 7 in the April issue, i.e. the special colour, graphics and other display control characters; provide blanking for the duration of these characters (since these are non-display characters); and inhibit the character generator or graphics generators as appropriate.

At the beginning of every row of characters all the latches are set to white, alphanumeric, steady according to the teletext convention. The output

of the decoder is applied to the output unit which provides R, G, B signals to the guns of the cathode-ray tube.

Non-control codes are applied to the alphanumeric character generator which generates the required character pattern. This generator also receives a 4-bit line address from the sync generator, which indicates which line out of the ten lines required for character display has been selected at any one time. When a line of dots is fed out from the character generator it is entered in 5-bit parallel form in a 5-stage shift register and clocked out in the next  $1\mu\text{s}$  period at the 8MHz rate, under the control of the 8MHz clock.

If a graphics control character is displayed, a latch is set in the display control codes decoder to indicate that all subsequent characters are graphics. The inhibition is lifted, however, in the case of the "blast-through" characters in columns 4 and 5 of Fig. 6 in the April issue.

Generation of graphic symbols is carried out under the control of vertical and horizontal bright-up waveforms, generated in the graphics generator. The horizontal bright-up waveform picks up left, right or both columns of the graphics symbol while the vertical bright-up waveform picks up one or more of the top, middle or bottom pair of squares in the graphics symbols. The 7-bit graphic character is decoded with the aid of these two waveforms and control signals applied to the output unit.

The display of the Viewdata cursor is initiated by the address selector, which notes the coincidence of input and output memory addresses and enables an exclusive-OR gate in the output unit. This causes normal display of characters when the cursor is off, but inverted display (i.e. black on white) when the cursor is on. Thus characters on display may be read through the cursor.

Character rounding is provided in the character rounding unit when this feature is required, i.e. mostly with large screen displays. Character rounding is initiated by the odd/even signal generated together with the line interlace pulse in the sync generator unit. A second alphanumeric character generator unit similar to unit (3) may be required, both units operating simultaneously out of step by one line of the  $7 \times 5$  character matrix. The two outputs, one delayed with respect to the other, are compared in the character rounding unit and additional dot pulses generated half way in the 8MHz dot interval and transmitted to the output unit to give the required result.

The use of character rounding is not necessary in the case of the small-size Viewdataphone display for use in the office, and this results in a useful simplification.

(To be continued)

A limited number of commercial television sets containing Viewdata/teletext decoders are now being manufactured for marketing trials of Viewdata due to start in March 1978. In a later issue we hope to publish an article outlining the main features of a typical commercial set of this kind.



# Letters to the Editor

---



---

## MOBILE RADIO PLANNING

---



---

Recent editorials in your journal have complained about the secrecy surrounding the planning of mobile radio in the UK and have also referred to a document on the subject, which has been given a limited circulation by the Pye company. Unfortunately, the Pye document, which is issued in two versions, is not available to the generality of your readers so it does not contribute greatly to the ventilation of the subject which you rightly judge to be desirable. I am one of the small number of people who have been privileged to see both the government and commercial documents and my views may therefore be of interest. I trust I am not giving away state secrets when I say I find the overall picture confused.

You have expressed concern about the issues involved, particularly in relation to the forthcoming World Administrative Radio Conference to be held in Geneva in 1979. This conference may however be of less importance in the matter than you anticipate, for two reasons. First, the ability of the UK delegation to influence the international decisions affecting mobile radio must be necessarily limited. Second, many of the important decisions which have to be taken about mobile radio (like shall we have a Citizens' Band) are national ones and can be taken now before the WARC or after it. I trust that the *Wireless World's* interest in the subject is a lasting one and not tied to the WARC, which may possibly turn out to be something of a non-event as far as mobile radio is concerned.

As an example of a national decision, one of the most rewarding steps that can be taken to make more channels available for mobile radio is to split the u.h.f. channels from 25 kHz to 12.5 kHz. This would provide hundreds of additional channels and it is a step which can be initiated immediately. The Pye report in its full version agrees that this can be done and suggests a date for its introduction (1978), yet surprisingly this proposal is omitted from the later and shortened version. Splitting the u.h.f. channels was shown to be eminently practical no less than seven years ago by I.T.T. and one wonders why, if channels are really short, this proposal has been kept so long on the back-burner. In the meantime, the more 25 kHz u.h.f. equipment which continues to go into the field, the longer it will be before the channel splitting dividend can be reaped.

A puzzling feature which emerges from the current reviews is that mobile radio in the UK seems to make very poor utilisation of the spectrum available to it. A total of approximately 1,000 channels accommodates some 200,000 equipments, an average of only 200 mobiles per channel spread over the entire country. There are some 20 populous centres in the UK where each frequency can be repeated and this suggests an average of 10 mobiles per centre, ignoring all rural development which in itself cannot be negligible. The populous south east of England only accounts for about one fifth of the vehicle population so it is difficult to see that average channel loading can be very heavy even there. I am told that if you listen on many of the channels, which you are not supposed to do (more secrecy), message traffic is surprisingly light even in the London area.

A further point of concern is that other countries, notably the USA, Germany, Sweden and Denmark, seem to have been able to equip a much higher percentage of their vehicles within their existing frequency allocations. I believe a main factor in this has been better channel sharing arrangements and I have been long of the opinion that the UK channel sharing arrangements are unsatisfactory, discourage investment and are badly in need of review.

I have no doubt that mobile radio in the UK should be allocated more frequency space but it must be remembered that any such additional space must be taken from other important spectrum users. These users will certainly resist badly made claims. The present situation in which the long established mobile radio consultative machinery has failed to produce a unanimous report and a leading manufacturer is disputing the ministry viewpoint is a disturbing one and cannot strengthen any claims being made for more mobile radio frequency space. The frequency spectrum is one of our greatest national assets and claims for revised shares in it should be well made and be seen to be well made.

You have rightly sensed a serious failure and your journal's continuing interest in the matter can, I believe, only be beneficial.

J. R. Brinkley,  
Redifon Ltd,  
London, SW18.

---



---

## DO-IT-YOURSELF BIOFEEDBACK

---



---

A number of articles published in the technical press in recent years give popular accounts of biofeedback, together with details of the instrumentation required to "do it yourself". I write to draw attention to two aspects of this which are disquieting to the professional biomedical scientist.

The first is the impression of technological simplicity that is often conveyed. Probably the simplest demonstration of biofeedback is to convert the electrical activity of the muscles - the electromyogram - into sound using an audio amplifier, or a visual display via an oscilloscope, and hear or see what happens when a muscle is tensed or relaxed. The arm muscles are convenient and all that is required is to (a) clean and abrade the skin overlying a muscle in two places, (b) fix small metal plates to these areas with surgical plaster and a conducting interface, e.g. cotton wool soaked in salt solution, and (c) connect these "electrodes" to the display

system via a differential amplifier. The overall gain of the system should be sufficient to cope with millivolt signals. This procedure would not meet the professional standards of the clinical neurophysiologist, but would certainly demonstrate biofeedback and help one to learn to relax muscles.

Other physiological variables are not so easy to use in the feedback situation, however. Most publicity has probably been given to the electrical activity of the brain, the electroencephalogram, or e.e.g. and particularly that part of it in the 8 to 14 Hz frequency band, the alpha rhythm. Here the technological requirements are much more stringent and it is exceedingly difficult for even the professional electroencephalographer to record his own e.e.g. There are two reasons for this. One is that the signals are very much smaller in amplitude, of the order of tens of microvolts, and so require higher gain amplifiers and more careful attention to common mode rejection. The second reason is that the electrodes will detect other signals as well as the e.e.g. These will be physiological from the muscles, skin and other tissues around the head, and also physical from electrodes, interference fields, and mechanical displacement of electrode relative to skin surface. All of these artefacts can quite easily be larger in amplitude than the e.e.g., and will certainly have components in the same frequency range. In the biofeedback situation it is usual to filter the e.e.g. with a bandpass filter to reject all but the alpha rhythm, or other frequencies of interest. It is therefore impossible to tell whether the output signal is in fact e.e.g. or artefact without considerable experience of e.e.g. recording.

The professional e.e.g. technician spends several years learning to record these signals, to differentiate true e.e.g. signals from artefacts, and to improve technique to reduce these artefacts to a minimum. Appropriate application of electrodes to one's own scalp is very difficult indeed.

The second area of disquiet concerns the interpretations of the subjective effects of biofeedback, particularly the so called "alpha experience". It is generally assumed in popular articles that learning to enhance alpha activity via biofeedback invariably results in a state of mind associated with tranquility, relaxation, meditation states, and generally pleasant feelings. Experiments which have attempted to control for the effect of feedback on these factors have not always confirmed these claims however. Thus Sacks et al<sup>2</sup> used well established methods for measuring subjects' feeling and mental states and found no difference when subjects enhanced their alpha to maintain a light on or inhibited it to maintain the light off. In a study of 140 subjects by Travis et al<sup>3</sup>, "under both eyes-open and eyes-closed conditions, approximately 50 per cent of the subjects reported that alpha enhancement was 'pleasant' and 50 per cent 'unpleasant/neutral'". Plotkin and Cohen<sup>4</sup> concluded from their experiments that "... undirected, free-flowing thought or thoughtlessness, and pleasant emotional states, are in no way intrinsically associated with enhanced occipital alpha strength ...".

These are just a small selection from many research studies urging caution in the interpretation of alpha feedback results, and of course, one could quote an equal number putting a more optimistic point of view. The popular interpretation of the "alpha experience" is by no means established however.

There is no doubt that biofeedback is an exciting and valuable research tool. Whether it will be clinically useful is still to be proved<sup>5</sup>.

The laboratory situation of "do it yourself" enthusiasm which accompanies it may indeed result in subjective feelings of relaxation or other pleasant sensations. It does not necessarily follow that these are directly due to subjective control over brain mechanisms. After all, as Lynch and Paskewitz have pointed out<sup>6</sup> "Simple physical manoeuvres like closing or opening the eyes have not been related to mood changes of the sort reported in feedback situations and yet such eye manoeuvres markedly affect alpha density."

J. C. Shaw,  
MRC Clinical Psychiatry Unit,  
Graylingwell Hospital,  
Chichester, Sussex.

**References**

1. Cooper, R., Osselson, J.W. and Shaw, J.C. "EEG Technology", second edition, Butterworth, London, 1974.
2. Sacks, B., Fenwick, P. B. C., Marks, I., Fenton, G. W., and Hebden, A. An investigation of the phenomenon of autocontrol of the alpha rhythm and possible associated feeling states using visual feedback. *Electroencephalography and Clinical Neurophysiology*, 32, 461, 1972.
3. Travis, T. A., Kondo, C. Y. and Knott, J. R. Subjective aspects of alpha enhancement. *British Journal of Psychiatry*, 127, 122-6, 1975.
4. Plotkin, W. W., and Cohen, R. Occipital alpha and the attributes of the "alpha experience". *Psychophysiology*, 13, 16-21, 1976.
5. Blanchard, E. B. and Young, L. D. Self-control of cardiac functioning: a promise as yet unfulfilled. *Psychological Bulletin*, 79, 145-163, 1973.
6. Lynch, J. J. and Paskewitz, D. A. On the mechanisms of the feedback control of human brain wave activity. *The Journal of Nervous and Mental Disease*, 153, 205-217, 1971.

**DIGITAL FILTERS USING MICROPROCESSORS**

I am very grateful to Mr V. J. Rees for giving the extra bit of explanation I needed to understand digital filter principles (October 1976 issue). And in spite of the possible shortcoming of the article, I think that the criticisms of M. J. Brazier (December 1976 letters) are unjustified.

Firstly, even if it is obviously impossible to "operate the filter in real time" on a calculator, it is very instructive to do so for a student and very informative for a designer.

Secondly, I did not have any problem in realizing from the example that the coefficients were constant unless the filter characteristics were time varying.

Thirdly, there is an improved form of the digital filter which requires only one multiplication and two subtractions. These can be performed within the suggested 100 microseconds on a Motorola 6800 in single precision (see appendix).

Finally, digital signal processing is more likely to be used in process control or similar applications where the frequencies involved are much lower. Present "slow" microprocessors will certainly be used in that area, if they are not already.

Gérald Garon,  
Otterburn Park,  
Quebec, Canada.

**Appendix**

The improved form of digital filter is shown in the figure, and the 6800 programme to implement it is given below. The coefficient is inserted in the programme by putting NOP in the bit positions where the coefficient has

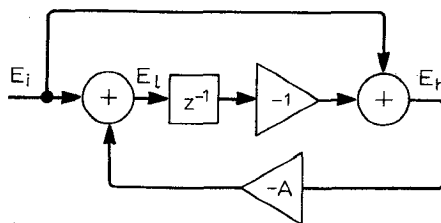

$$E_h = E_i - E_l z^{-1}$$

$$E_l = E_i - A E_h$$

- E<sub>i</sub> input signal
- E<sub>l</sub> low pass output
- E<sub>h</sub> high pass output
- A coefficient e<sup>-aT</sup>
- z<sup>-1</sup> delay T

zeros and ABA where it has ones. In the example, the coefficient is 11101100<sub>2</sub> (0.921875). The execution time of this programme is independent of the coefficient value. For any given coefficient value, it is possible to speed up the program by either omitting the NOPs or using Booth's algorithm.

**Programme**

| INSTR | CLA B              | Clear B on initial start                    |
|-------|--------------------|---|
| 4     | NWSMP LDA A SAMPLE | Get new sample                              |
| 4     | STA A SVSMPL       | Save it                                     |
| 2     | SBA                | EH = E <sub>i</sub> - E <sub>l</sub> (PREV) |
| 5     | STA A HPOUT        | Output High Pass                            |
| 2     | TAB                | Get Ready For Multiply                      |
| 2     | CLA                |   |
|       |                    | Multiply 0.158B                             |
| 2     | NOP                |   |
| 2     | ASR A              |   |
| 2     | NOP                | 0   |
| 2     | ASR A              |   |
| 2     | ABA                | 1   |
| 2     | ASR A              |   |
| 2     | ABA                | 1   |
| 2     | ASR A              |   |
| 2     | NOP                | 0   |
| 2     | ASR A              |   |
| 2     | ABA                | 1   |
| 2     | ASR A              |   |
| 2     | ABA                | 1   |
| 2     | ASR A              |   |
| 2     | ABA                | 1   |
| 2     | ASR A              |   |
| 2     | NEG A              | Make Result Negative                        |
| 3     | ADD A SVSMPL       | EH = E <sub>i</sub> - A. EH                 |
| 5     | STA A LPOUT        | Output Low Pass                             |
| 2     | TAB                | Save In B                                   |
| 4     | BRA NWSMP          | Go Get Next Sample                          |

67 microseconds

**References and further reading**

- Gold B. & Rader C. M., "Digital Processing of Signals," McGraw-Hill, 1969.
- Mick J. R. (ed), "Digital Signal Processing Handbook," Advanced Micro Devices, 1976.

**BROADCASTS MODULATE PAGING SYSTEM**

Over a period of more than a year I have heard on 27.26MHz a weak carrier which is amplitude modulated with material corresponding to that of the Radio 3 transmission on 647kHz including, prior to 0700 local time, material from the BBC World Service.

At intervals this carrier disappears for about ten seconds and it was later noticed that these interruptions coincided with

periods of calling signal and short speech announcement from a hospital paging system on 27.23MHz. A band of noise embraces this latter frequency and this too is interrupted during operation of the paging system.

During evening hours of darkness the noise band can be resolved as a large number of separate carriers, some of which are modulated with programme material which matches certain transmissions in the m.f. band around 600 kHz.

By now some of your readers will have suspected, as I do, that the receivers of the paging system are of the superregenerative type and this is borne out by quenching of the noise when the calling carrier is switched on.

What is not so clear, however, is the mechanism by which the sidebands are modulated by transmissions in the medium frequency band and it is this peculiarity that your readers may be able to suggest a reason for.

I should explain that my receiver is a double superhet with i.fs of 4.034MHz and 455kHz, but spurious operation can, I believe, be ruled out and tuned aerial traps have confirmed that the signal I receive is borne on 27MHz. It is moreover occasionally subject to aircraft flutter.

My receiver location is about 2½ miles from the hospital concerned and the signal is a weak one but in an area within a few hundred yards of the grounds it provides an almost usable relay of Radio 3.

All this may be only a minor instance of spectrum pollution but I am reminded that frequencies of the order of 27MHz are allotted to model aircraft control.

I do not think, however, that there is any likelihood of these aircraft being affected by a new-style Bermuda triangle!

Gwilym Dann,  
Chipstead,  
Surrey.

**RIAA EQUALIZATION IN PRE-AMPLIFIERS**

Having just read Graham Nalty's and D. Self's arguments on disc RIAA equalization in your March issue, I would like to add a few words.

While I was living in Japan I designed an expensive pre-amplifier for a well known company which has earned good reviews everywhere. Anyway, the RIAA circuit was conventional in that the time constants were in the feedback loop. However, the problem is that at high frequencies the amplifier ultimately becomes a unity gain circuit above about 60kHz so compensation becomes a real problem; therefore in its open loop form the amplifier starts to roll off at a low of 30Hz and t.i.m. never is perfect, although in my case it was lower than that of any of its competitors.

I have for myself designed a totally passive RIAA amplifier with accurate equalization from below 10Hz up to beyond 200kHz. I had succeeded in getting as good an input over load value from 20Hz to 20kHz to compare with feedback methods.

As to listening and also square wave tests, the purely passive circuit always performed better (I always use polystyrene and polycarbonate capacitors as they are more musical!). This went through many hours of listening, with many types of cartridges, power amplifiers and loudspeakers.

I sacrifice 3dB of signal-to-noise since impedances are not perfectly optimum and distortion at 2dB below clip is only 0.03% over 20-20kHz.

But this is the way thoughts are going in Japan.

Tim de Paravicini,  
London NW6.

---

## ADVANCED PRE-AMPLIFIER DESIGN

---

In reply to Mr Williamson (Letters, April), I think there are mainly two points to be made. One, that any pre-amplifier should have adequate signal handling capacity in excess of the performance of any pickup cartridge both dynamically and in pure consideration of the amplitude of signals. Second, that as far as I am concerned the two pickup cartridges which are capable of giving peaks in excess of 200mV are the Ortofon SL15 with appropriate transformer and the Decca London cartridge.

The reference to signal peaks of 80 cm/s observed on gramophone records came from the book "Hi-Fi Systems" by G. King where there is a graph illustrating the velocities measured on gramophone records at various frequencies.

I nominate my favourite charity as the Musicians Union!

A. J. Watts,  
SGS-ATES (United Kingdom) Ltd,  
Aylesbury,  
Bucks.

---

## LONG WAVES FOR AMATEURS?

---

I am normally in favour of amateur radio but a statement in your March 1977 issue (p. 78) that the USA may request a frequency allocation in the l.f. band for amateurs fills me with anger. How can anyone be so wickedly irresponsible or unappreciative of the value of long wave channels!

Just in case the unique feature of long wave transmission has slipped anyone's mind I would point out that the long wave channels are the only ones capable of giving reliable, fade-free global communication without resorting to the use of satellites.

In my opinion it shows a serious lack of appreciation of the potentialities of these frequencies to allow anyone to use them just for low power local broadcasting, and hence it is quite wrong to allow more than one transmitter on each channel unless the carriers are synchronised and they are radiating the same programme.

H. G. May,  
Barton-on-Sea,  
Hants.

---

## AUDIBILITY OF PHASE EFFECTS

---

In view of the continuing controversy in these columns over the audibility (and hence undesirability) of non-linear-phase shifts in an audio signal — i.e., phase shifts which leave the harmonic structure unaltered but distort the signal waveform — the following

recent observations of mine may be of interest to your readers. In particular, they may enable readers who have built the *Wireless World* Dolby B noise reducer to verify some of these effects for themselves.

Having completed the noise reducer kit from Integrex Ltd., I was somewhat surprised to find that, listening to the built-in calibration signal at the monitor output (with the input selector in the auxiliary position), I could hear a subtle but distinct difference between the apparent purity of the (approximately 456Hz) tone with the record/play button in and the sound with the button out. Reference to the circuit diagram shows that the only change introduced by this switch is the insertion of a unity-gain polarity inverting stage into the output circuit. Further investigation showed that the gain of this stage was indeed unity (within 0.02dB) and its harmonic distortion very low (of the order of 0.02% t.h.d.). So it clearly was not the culprit. It was at this point that I measured the calibration oscillator t.h.d. and found that this was 2.66%, comprised of 2.57% second harmonic, 0.62% third harmonic, 0.25% fourth harmonic and approximately 0.16% higher-order harmonic distortion. The pronounced second harmonic distortion, like all even-order harmonic distortions, rendered the waveform asymmetrical; this asymmetry was sufficient to be just barely visible on an oscilloscope.

Here, then, was the explanation of the change in sound quality observed before. It is known from recent work<sup>1, 2, 3</sup> that the inner ear does not respond symmetrically to compression and rarefaction, and at lowish frequencies (below say 1kHz) where the rate of neuron firings can be modulated by the audio waveform, the ear performs to a certain extent at least like an asymmetrical waveform detector, responding more to one signal polarity than to the other. In this connection reference should be made to the publications cited in references<sup>1, 2</sup> and<sup>3</sup>, and in particular to the work of J. H. Craig and L. A. Jeffress. By switching from "record" to "playback", and hence inverting the slightly asymmetrical calibration waveform, the fact that the ear treats compressions and rarefactions unequally resulted in an audible difference in the tonal quality. Of course, this polarity reversal of the asymmetrical signal is equivalent to a phase shift of the harmonics relative to the fundamental, and so this result has direct relevance to the current discussions on the audibility of phase distortion. The letter by M. A. Gerzon<sup>4</sup> should also be consulted for corroborative evidence.

The above explanation has subsequently been confirmed by introducing polarity reversals at other points in the reproduction chain, with the same effect. The audible effect of the polarity reversal in the Dolby noise reducer could be exactly counter-balanced by another polarity reversal later in the chain. In this way, it was possible to rule out transducer asymmetry as a contributory cause. The audibility of the polarity reversal has also been confirmed by friends on whom I have repeated the experiment.

The audibility of the polarity reversal depends to a great extent on having the volume level just right — neither too loud nor too soft. This also agreed with the earlier experiments cited. The change is audible on both headphones and loudspeakers, but for convenience the former were used primarily in my tests.

I would like to invite readers who have constructed the *Wireless World* Dolby B circuit to try this experiment themselves. Of course, I cannot vouch that the distortion of

their calibration oscillators will be the same as mine and so produce the desired asymmetry! It should be emphasized that the change is *subtle*, and some perseverance may be required in order to hear the tonal difference. (Experiment also with the volume level.) The noise reduction should be switched "off." (Switching it "on" exaggerates the difference in the right-hand channel, by pre-emphasizing the higher harmonics when in the "record" mode and de-emphasizing them when in the "playback" mode. The left-hand Dolby side-processor loop is not performing its normal function when the calibration oscillator is on, and so the left-hand channel does not display this further effect. Thus it may be found helpful initially to monitor the right-hand channel output with the noise reduction switched "on," to serve as an aid in learning what to listen for. The change under these circumstances is, however, *not* a simple polarity reversal.)

At first sight, all the above would seem to bear only on the audibility of polarity reversals of non-sinusoidal waveforms. As such, it strongly suggests that an effort should be made to standardize the polarities of the whole recording/reproduction chain from microphone, through record or tape, to loudspeaker. This suggestion has been made before, for example by D. S. Stodolsky<sup>1</sup>. It also serves as a warning to those who conduct A/B comparison tests on audio components without taking into account the possible relative polarity reversals which such components can introduce. For example, some power amplifiers are inverting from input to output, whereas others are non-inverting. Some of the alleged differences between components compared A/B may be due to such oversights.

Our observation *does*, however, indeed bear directly on the vexed question of the audibility of non-linear-phase shifts for the following reasons. Non-linear-phase distortion results in waveform distortion, and hence can change the symmetries of the signal waveform. As shown above, such symmetry changes can be detected by the ear, and so such phase distortion must be classed as undesirable, whatever the component is which introduces it. So, to conclude, it is my belief that phase distortion is audible under suitable circumstances, that more effort should be devoted to obtaining bounds on the allowable phase distortion on programme material (by means of properly conducted experiments with source signals which have not been phase-distorted by the audio chain), and that in principle the goal of phase-linearity (at least over the bulk of the audio band) is a desirable one which is worth pursuing, especially in transducers.

Stanley P. Lipschitz,  
University of Waterloo,  
Ontario, Canada.

### References

1. Stodolsky, D. S. "The standardization of monaural phase", *I.E.E.E. Transactions on Audio and Electroacoustics*, vol. AU-18 (1970), 288-299.
2. Hansen, V., Madsen, E. R. "On aural phase detection, Parts I and II", *J. Audio Eng. Soc.*, vol. 22 (1974), 10-14 and 783-788.
3. Schroeder, M. R. "Models of hearing," *Proc. I.E.E.E.*, vol. 63 (1975), 1332-1350.
4. Gerzon, M. A. Letter to the Editor, *Wireless World*, vol. 82, March 1976, 60-61.

Further letters on the audibility of phase effects, and also letters on transient intermodulation distortion in amplifiers, will be published in a later issue.

# News of the Month

---



---

## Annand and technology

---



---

Mobile radio should get some of the frequencies freed from 405 line tv transmissions in 1982, Professor Geoffrey Sims said at a press conference marking the publication of the Report of the Committee of enquiry into broadcasting of which he was a member. Asked what would happen to the 405 line channels and whether they would be used for citizens' band radio Professor Sims said: "I think there are certain problems about these frequencies. They are not well suited to colour television. Certain of them, band three for example, could be reserved for a colour television channel, but not all of these frequencies will be used for television services. For example they could be used for mobile radio services."

Pressed further to say why a report over 500 pages long which had been awaited eagerly as a sign of the way new techniques would affect broadcasting in the future contained only 20 pages on technology Mr Sims pointed out that there were in fact 35 pages, or two chapters on technology. "We are all aware" he said, "that we are surrounded by new forms of technology which can be deployed in broadcasting." The difficulty was that there was a shortage of money to develop these techniques, and a shortage of good material to broadcast by them. All sorts of techniques, from fibre optics to satellite transmission were available, "but the way it's done is neither here nor there provided you can afford to do it some way. Either new technology is not developed to the point where it would be sensible to create these new large networks, or there is a lack of programme material. It's all right to talk about a fourth or fifth channel but when you come to the 24th or 25th, which is what these things could provide, the whole question becomes a different matter." Citizens' band was outside the scope of the committee's remit, but "It must be introduced at frequencies which do not interfere with public broadcasting."

Professor Sims's final point on the

adoption of new technology was that the u.h.f. investment programme was still going forward. "By the early 1980s some u.h.f. transmitters will be going out of service, and some people who now get programmes won't get them unless these are replaced." Mr Phillip Whitehead, MP, a member of the committee, added that citizens' band was mentioned at the end of chapter 24. "We can't take that in this country." The kind of service that existed in the United States, on 27MHz, would cause "grave interference with services which are much more important."

The report makes scathing criticisms of the British television manufacturers, and presses for tighter control on the illegal use of c.b. equipment, including banning its sale as well as its manufacture and importation. The committee also recommends the setting up, as suggested in evidence by the National Electronics Council (see *Wireless World*, October 1975, p.447) of a telecommunications advisory committee to advise the government on the prospects for and implications of technical developments for all telecommunications, including broadcasting.

The committee over-ruled suggestions by the Newspaper Publishers Association and the Newspaper Society that teletext development should be held back for five years "to enable newspapers to adjust to the new competition." Neither need they be consulted about these developments. "We recommend that the BBC and IBA should be authorised to provide CEEFAX and ORACLE as an extension of their existing services." There should however be an enquiry by the new Public Enquiry board.

*Wireless World* will publish a full account of the less publicised aspects of the report in our next issue.

---



---

## Battery car charges while braking

---



---

The Department of Industry is funding the development of a braking system for electrically powered vehicles which will feed the energy normally lost during braking back into the battery. Although the technique adopted, using the traction motor as a dynamo during braking, is fairly well established, up to the present time, the Department say, "regenerative braking systems have required a considerable number of additional components in the control circuit and hence have been costly, have necessitated critical adjustments to provide the requisite safety margin against miscommutation (which would effectively short circuit the battery and blow the traction fuses) and were not capable of operation at low road speeds."

The solution, developed after joint funding by the DoI and Cableform Ltd,

is to use a Cableform Pulsomatic Mk 10 controller, developed for control of the acceleration of the vehicle, to control braking as well. Mr P. F. Hodges, field sales manager of Cableform, told *Wireless World*, "We started looking at this two years ago and, like everyone else, we ended up with about 250 discrete electronic components in the circuit. Then we noticed that the acceleration characteristics had so much in common with the braking characteristics that we could use the same controller for each function with only 120 components, and of course, as always happens when you reduce the number of components, the reliability shot up."

The detailed operation of the device is complicated, but in essence it overcomes the difficulty of absorbing the large amounts of energy that are generated by motors in a short time during braking. On the one hand there is a large current surge which may destroy the battery, and on the other a large voltage surge which is hostile to the semiconductor sections of the thyristor control circuit. Cableform have managed to mitigate the effects of both by feeding the energy back in smaller, more manageable quantities over a longer period. They have also overcome the reduced braking rate at lower speeds. The Department of Industry appear delighted with the device, and full of praise for Cableform.

The money, £16,500 to match Cableform's contribution, was channelled through the transport section of the Research Requirements Board. The Department of Industry sees it as its duty to put help under one of several publicised schemes into any company or organisation which comes forward with a proposal which the Department of Industry judges to be viable. That means the proposal must produce sales, and a project which represents solid judgement and good engineering will be preferred to one which, as one spokesman put it, "is a technological marvel that collects dust on someone's shelf."

One of the tasks with which the Department was charged was to look at the technical options offered by electric vehicles and the amount of energy that could be saved in using them. They came across "an ingenious way of simplifying a regenerative control". In particular, Cableform's design, described in three versions in the patent specification, eliminates the need for any tricky adjustments, according to the DoI.

---



---

## ITU conference results

---



---

The sense of accord at the ITU Broadcasting Satellite Conference, which ended in Geneva on February 13,



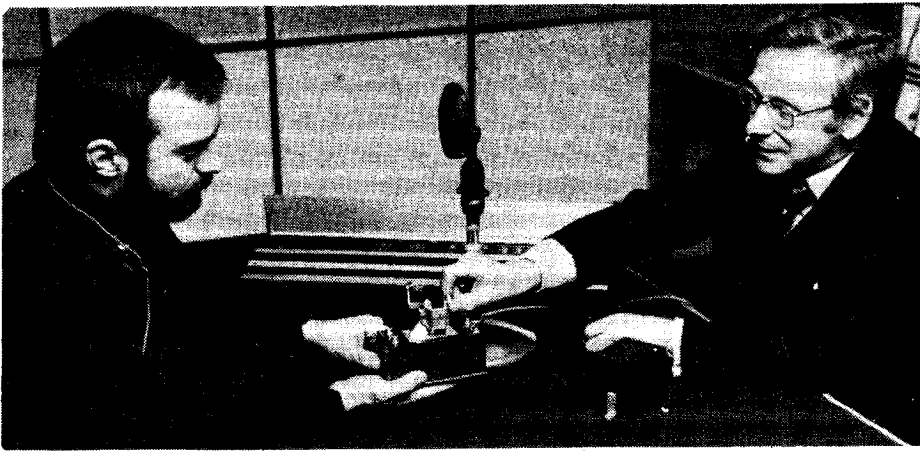

Johnny Longden, chief engineer of BBC Radio London (right) examines a forerunner of the audio amplifier with David Clifton, until recently presenter and producer of the station's Sounds Good programme. The valveless amplifier was originally used to drive loudspeakers from crystal circuits normally able only to power headphones. According to Longden the device, made by S. G. Brown, may have been intended for morse code rather than audio, since there was a peak of 12dB at around 1.5kHz.

Sounds Good has been running on Radio London almost since the station opened in October 1970. If the Annan Committee gets its way the BBC will lose all its local radio stations (full report next month).

was such, according to one report, that no votes were taken even on matters about which the 660 delegates from 111 countries disagreed. The amount of work done was therefore prodigious. A plan was adopted which gave every country present, with the exception of those in region 2, the Americas, frequencies and orbital positions for satellite broadcasting which will come into force on January 1, 1979. Region 1 (Europe and Africa) was given 40 channels and Region 3 (Asia and Australasia) 24. Region 3 has the frequency band from 11.7GHz to 12.2GHz, and region 1 up to 12.5GHz. The allocations are in the form of a 42-page table worked out by computer in channel order from 1 to 40. The plan is valid for 15 years. The final document produced by the conference, some 150 pages, contained 16 articles, including the plan, 11 annexes, a final protocol, nine resolutions and eight recommendations, as well as a small section relating to the rearrangement of the radio regulations, some additional regulations and a recommendation that they be published this September in good time for the 1979 WARC in Geneva, when the regulations agreed last month will form the basis for proposals to that conference.

Region 2, dominated by the United States, decided to wait for its final orbital station and frequency allocation until they hold their own regional administrative conference in 1982. Contingency plans have been made establishing a claim to orbital space, and each country in region 2 will get at least four channels at the 1982 conference.

The technical details of the plan, we believe, include the following: the

broadcast signal will be either f.m., which will predominate, or another type of modulation which has at least the same interference standards; circular polarisation; at the edge of the coverage area in regions 1 and 3 the power flux density will be  $-103\text{dBW}$ , needing a receiver with a figure of merit (defined as the aerial gain divided by the system noise temperature in degrees Kelvin) of  $6\text{dB/K}$  and a 90cm aerial. This is the equivalent of an effective isotropic radiated power of 67 dBW at the satellite; and a nominal spacing has been set for the satellites in regions 1 & 3 of  $6^\circ \pm 0.1^\circ$  at the equatorial orbit. Narrower spacings are allowed at lower powers provided interference does not result.

The American countries are adopting slightly different standards, it is understood. Their power will be  $2\text{dBW}$  lower at  $-105\text{dBW}$  at the edge of the coverage area, or a radiation from the satellite of  $63\text{dBW}$  e.i.r.p., needing a 1m aerial. As a comparison, the Canadian communications satellite (see WW, March, p40) has an e.i.r.p. of  $59\text{dBW}$ .

## IBA host EBU surround sound demonstrations

Working Party S of the European Broadcasting Union will be meeting at IBA Engineering HQ, Crawley Court, June 14-17 to investigate surround-sound broadcasting systems. The IBA will be giving demonstrations of five systems: BBC Matrix H, CBS SQ, NRDC 45J, Nippon Columbia UMX and Sansui QS. The aim is eventually to arrive at a single agreed system for the whole of Europe.

The IBA is currently exploring several surround systems, but still at a relatively early stage of its investigations and is anxious to complete them before making any formal statement of its views. "The choice of a preferred system involves questions not only of subjective performance" the IBA say "but also of the degree to which it would affect listeners relying on monophonic or two-channel stereophonic reception; whether it would significantly affect the coverage of the transmitting stations; whether it would cause, or be vulnerable to, interference to or from stations using adjacent channels and so complicate frequency planning; and of course the costs to broadcasters and listeners.

"It is also recognised that it would be highly desirable that the same system should be adopted nationally and internationally. In Europe the adoption of a particular system is primarily a question of achieving general agreement among the members of the European Broadcasting Union and ultimately the CCIR. Thus while the IBA and other members of EBU are currently investigating and making individual contributions in this field it is hoped that it will prove possible to agree on the system best suited to European broadcasting. The work in this area is being shared through Working Party S of the EBU."

During the meeting of the Working Party the IBA expects, with the co-operation of the BBC and the other broadcasters concerned, to stage a comprehensive series of demonstrations and experiments based on a number of different proposals, using different types of programme material.

"It must be stressed however that these experimental demonstrations to Working Party S cannot be expected to lead to an immediate recommendation by the EBU. It is only after consideration in detail of the technical and economic factors involved that European broadcasters are likely to be satisfied that a wise and prudent choice has been made from among the proposed systems, all of which appear to have useful features but also some ambiguities. It is interesting to note that despite the intensive work in this area since 1972 in the United States of America no final recommendation has yet been made by the Federal Communication Commission."

## High speed track measurement

As the speed of passenger rail transport increases it becomes more necessary than ever to make sure that track is fault-free. The High Speed Track Recording Coach, which has already gone into service with British Rail, uses gyroscopes, accelerometers and mini-

computers to take track measurements at speeds up to 125 m.p.h. These measurements enable two types of fault to be located; those related to passenger comfort and those related to safety. Parameters measured include vertical (top) and horizontal (alignment) rail-profiles, cross-level (cant), curvature, gauge and slope. An Interdata model 70 digital computer samples the analogue measurements and allows other parameters such as twist, to be derived. The track assessments employ calculations based on the statistical standard-deviation principle.

Data from the gyroscopes and accelerometers is processed using a Membrain digital/analogue computer, acting as an integrator, to provide a measure of the dynamic motion of the coach. This enables the main computer to distinguish between cants and curvatures due to natural slopes and corners and those due to faults.

Vertical measurements are made to within 1mm using potentiometric displacement transducers mounted above the centre of running wheels. Lateral sensing, however, is by a non-contacting optical system. Light projectors are mounted on the bogies and arranged so that a small area of each railhead is illuminated. The reflected illumination from the railheads is converted into a video waveform by linescan cameras so that the gauge face, where the illumination intensity changes rapidly, can be sensed, to an accuracy of about 2mm, by using a threshold detector. While an ultra-violet recorder monitors the real-time analogue data, a 14-channel f.m. magnetic recorder stores this information for later playback at The Railway Technical Centre in Derby, where detailed studies can be made. In addition, there is a magnetic tape recorder which is used to store the digital data and act as a transfer medium for the main computer. A character printer also provides printed pages of data indicating track statistics at 200m intervals.

This coach, a result of work by British Rail's Research and Development Division, will run over 80,000 miles each year checking most of Britain's 21,000 miles of track. The existing system of track recording has been in use for over 20 years and is often limited to a speed of 20 m.p.h.

Other countries also have track geometry coaches but this, the first to use a computer, is believed to be the most accurate and reliable.

British Rail are also collaborating with Harwell in the development of a new system for their Ultrasonic Test Train. At present, data from the train, which looks for defects such as cracks in rails by recording the reflections of ultrasonic pulses, are recorded on film before subsequent interpretation by a computer system at Paddington. The new system will be fully automated and will save about one mile of film for every

100 miles of track inspected. Ultimately, it is hoped that the complete evaluation will be made on board the vehicle by using mini-computers. This real-time system, which could increase the inspection speed from 20 m.p.h. to 40 m.p.h., is expected to be installed by the summer of 1978.

British Rail is confident that the Recording Coach and the Ultrasonic Test Train are likely to be of considerable interest to railways throughout the world and, together with its consultancy company, Transmark, and Harwell Laboratories, it is taking steps to sell them in Germany and Eastern Europe. According to Transmark, the coaches, which are custom-built units, will be taking a stand at the American Railway Supplies Exhibition in Chicago.

---

## Rise in components industry morale

---

The destinations of the £20 million of government funding for the electronic components industry (WW March p39) became a little clearer at a press conference to mark the merging of the Electronic Components Board with the larger Radio & Electronic Components Industry Federation, held on March 11. Mr M. St A. Eley, of Plessey, said, "We won't have the final say in how or where the money goes, but I think it will be going towards projects that are convincing enough to the Department [of Industry], whether from a small, large or medium sized company."

Former director of the ECB Sir Ronald Melville, now an additional director of the new Electronic Components Industry Federation, said, "A lot of thought will be given to what use the technology is to be put." As well as being used for R & D the accent would be on the creation of new jobs and the building of factories. Eley added that the Department of Industry would sift potential projects very carefully. The announcement of the first successful applications is expected within a maximum of two months. The Secretary of State for Industry, Mr Varley is said to be already impatient to have the money available.

The formation of the ECIF, which first met on February 23 under the chairmanship of Jack Akerman of Mullard, coupled with the prospect of Government money, appear to mark a heightening of morale in the industry. Also contributing to this is what the ECIF calls the "five star treatment" that the industry will get as one of the five special industry sectors in the Government's industrial strategy, worked out with the National Economic Development Council and the trade unions. It appears that it is still no clearer what this "five star treatment" means and, asked by *Wireless World* to put a little

more flesh on the skeleton the ECIF council were clearly at a loss. Akerman seemed satisfied with the Government's attitude, however: "It means that the Secretary of State will take a personal interest in the industry. In effect, we have got an open door to go straight to the government, up to cabinet level if necessary, to put forward our views."

Also indicative of a more positive approach on the part of the industry is the reduction of emphasis on import controls. "What we are pressing for," said Jack Akerman, long the leading campaigner for controls, "is effective import surveillance." This meant that they would expect to be able to retaliate against the importation of colour sets made by our European trading partners using tubes made in the Far East. "We want fair trading, and effective import surveillance so that we know what is going on. For example the declaration of current domestic value on the import documentation."

Commenting on the £20 million funds he said, he regarded it as merely the first instalment, although "We don't want to give the impression that this industry exists solely on the basis of taking its cap to the government. We must be careful that we don't come over as a lame duck."

ECIF members seem to feel that large research and development expenditures may have to be forgone in favour of less glamorous activities: "We do know that the government wants the money put into the sharp end rather than the blunt end. It's tempting to put the money into R & D but we should put the money into marketing and making our product acceptable abroad."

---

## Digital course

---

Chelsea college will hold a one week course in Digital system design beginning May 16. The course, says the Department of Electronics, "is designed to give practising engineers and scientists a formal approach to the logical design of digital systems and should also prove useful to those engineers and scientists working in the field of digital electronics who have had no previous training in the methods of logic design." Professor J. E. Houldin, department of electronics, Chelsea College, Pulton Place, London SW6 5PR. 01-736 1244.

Owing to a communication error, the date of the course for teachers of the new A level course in electronic systems was published as June 18 to 20 instead of the correct date, July 18 to 20.

---

## "UD-45"?

---

In case you're wondering why articles on the NRDC system 45J decoding are appearing without there being any encoded material available, a clue to the

probable answer appeared in our last issue. No prizes, but if you want to do a bit of detective work stop reading here and read "NRDC surround sound system."

Concurrent with the gradual emergence of System 45J, moves were made to bring about a compromise settlement with surround-sound system codes. What seemed to be needed was a circle locus on the energy sphere that lay between two extremes. On the one hand was the BMX or "bimodal" matrix coding of Duane Cooper, used in the Nippon Columbia UD-4 basebands, and of Peter Fellgett's patent (with its one day priority over Bauer's similar "New Orleans" patent!) and on the other, was the amplitude coding of the Japanese Regular Matrix, to which Sansui's QS System approximated. The BMX vertical circle gave good mono performance but had a 90° phase difference between stereo channels, and the RM locus gave disastrous mono performance.

Now the best compromise is not necessarily the half way mark between these two extremes. The best plan may well have been to allow for a range of loci over which the balance may be tipped, in favour of reduced phasiness in the front section or else in favour of improved performance in mono, to suit the application. (Actually, the 45J system allows for such a range, but in its pairwise mixed options, rather than in its kernel form.) The BBC chose their locus to be about half way for the front part of the sound stage, and to be more like BMX for the rear part. Nippon Columbia tended to record front sounds with a reduced phase angle anyway when soloists appeared at centre front. The trend of the NRDC-sponsored project was departing from the originally patented scheme to a titled locus (but still a circle in its kernel form). It all looked very hopeful.

But this opportunity of producing a joint standard didn't appear to be grasped. Nippon Columbia went quiet; Sansui would have preferred to tilt their locus in the opposite direction; the BBC

seemed happy with what they had. Result: apparent stalemate. Yet looking at that article it is clear that *someone* is about to produce a 45J decoder. "... in the near future a decoder will be publicly demonstrated reproducing sounds via an arbitrary rectangle speaker layout..." We subsequently learnt from the UK section of the AES that Dr T. Takagi, who is general manager of Nippon Columbia's research laboratory, may also be taking part in a lecture that will include discussion of the 45J system... Perhaps this is the year to consolidate on the part of broadcasters and the record industry (page 35), lest this new enthusiasm should go off at half cock.

## Spacelab experiments

The first Spacelab mission towards the end of 1980 will carry 61 European, 15 American and one Japanese experiments. The mission, jointly planned between the National Aeronautics and Space Administration of the United States and the European Space Agency, will involve 222 experimenters from 16 countries. The experiments were chosen from 2,000 replies to invitations to participate. Eighty-one of the investigators come from Japan, 135 from Europe and the rest from Canada, India and Japan.

Spacelab will be launched aboard the NASA space shuttle, remaining attached to its three-man orbiter. The first mission carrying two instrument operators will last a week, but the re-usable Spacelab may stay in orbit for up to a month on subsequent occasions, carrying four operators, or "payload specialists", as they are called. The laboratory is expected to fly 50 missions during its ten-year life. The two operators will work shifts with the orbiter crew to ensure the laboratory, which is expected to complete 100 man hours experiments, is used round the clock.

The two payload specialist posts have now been advertised and they are expected to be filled in the summer of next year.

Of the nine experiments selected in the life sciences Britain has managed to capture three, compared with one each for France, Germany, Italy, Sweden, Switzerland and the United States. The three are:

Canal otolith interactions and adaptation in man (A. J. Benson of the RAF Institute of Aviation Medicine); Mass discrimination during weightlessness (Dr Helen Ross, Stirling University Department of Psychology); Personal miniature electrophysiological tape recorder (Mr Heinz Wolff, Clinical Research Committee).

Of the three Astronomy experiments Britain has one, France, Germany and Italy sharing the other two. It is a Mullard Space Science Laboratory

experiment on X-ray astronomy spectroscopy using a gas scintillation proportional counter. The four participants are Professor Boyd, Dr Brownlie, Dr Culhame and Dr Sanford.

Dr H. M. Rosenburg of Oxford University has one of the 39 material science experiments, Processing of composite materials in Spacelab. From the School of Chemistry, Bristol, Dr J. M. Haynes has two experiments: Kinetics of the spreading of liquids on solids, and a model study of interspatial instability and capillary hysteresis. Almost half a dozen materials science experiments put forward by the Department of Industry are being considered for funding, of which two or three will be successful. As we go to press the decisions had not been made.

## No decision yet on microwave landing system

A working party of the International Civil Aviation Organisation, meeting at the ICAO's headquarters in Montreal, has failed to reach agreement on the choice of a worldwide microwave landing system (m.l.s.). For two weeks beginning February 28 the All Weather Operations Panel of ICAO tried, in the final session of discussions that have lasted over a year, to decide among three rival systems: the British Doppler system; the American Federal Aviation Authority-sponsored scanning beam system; and a German ground-based system.

The search for a microwave replacement for the current instrument landing system (i.l.s.) began in the late 1950s when it became clear that, in view of the growth in air traffic, the current v.h.f./u.h.f. equipment was inadequate. However, the ICAO has endorsed the view that i.l.s. will be standard for another 25 years. First used in 1946, and adopted by the ICAO in 1949, it provides, essentially, three sets of information for the pilot: azimuth, or bearing, elevation and "distance to go." Three marker beacons five miles, one mile and 300 feet from the end of the runway provide distance. A "glide path" transmitter provides two overlapping beams modulated at 90 and 150Hz which are equal in received amplitude only when the angle of approach, normally 3°, is correct; above or below that angle one or other tone will predominate. A similar localizer beam operates down the centre of the runway, and another provides lateral information.

In a typical large airport installation meeting ICAO's "Category 3" standards (full instrument guidance from 25 nautical miles to the safe end of the runway with various subcategories for visibility) some 87 signals have to be

● continued on page 76

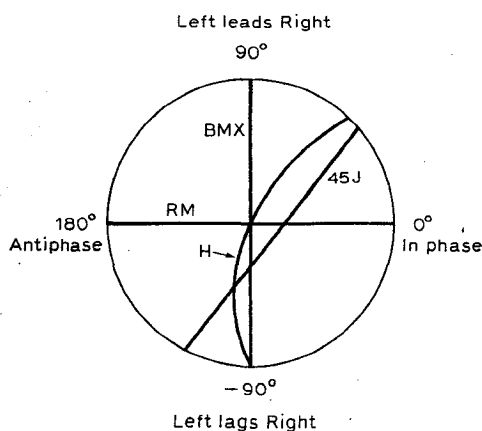

Side view of amplitude-phase energy sphere model shows how H and 45J "kernel" loci relate to the BMX code of UD-4 and the Regular Matrix of EIAJ

# Two-stage h.f. linear amplifier

by Helge O. Granberg

Motorola Semiconductor Products, Phoenix, Arizona

This article discusses the design of 50W and 300W linear amplifiers for the 1.6 to 30MHz frequency band, both of which employ push-pull design for low, even-harmonic distortion. This harmonic distortion and the 50Vd.c. supply voltage make the output impedance matching easier for 50 $\Omega$  interface, and permit the use of efficient 1:1 and 4:1 broadband transformers. The four 300W modules are combined to provide a 1 to 1.2kW p.e.p. or c.w. output capability. The driver amplifier increases the total power gain of the system to approximately 34dB.

## Bias voltage

The bias voltage source shown in Fig.1 is employed with each of the 300W modules and the preamplifier. Its basic components are the integrated-circuit voltage regulator MC1723C, the current boost transistor  $Tr_3$ , the temperature sensing diode  $D_1$  and the voltage adjustment element  $R_{10}$ . Advantages of this type of bias source are:

- line voltage regulation, which is important if the amplifier is to be operated from various supply voltages,
- adjustable current limit,
- very low stand-by current drain.

The supply voltage is reduced by  $D_2$  and  $R_{12}$  to a level below 40V, which is the maximum input voltage of the regulator. The base-emitter junction of a 2N5190, in a Case 77 plastic package, forms the diode  $D_1$  of which the temperature compensation has a slight negative coefficient. Current limiting resistor  $R_5$  sets the limit to approximately 0.65A, which is sufficient for devices with a minimum  $h_{FE}$  of 17, ( $I_B = I_C / h_{FE}$ ) when the maximum average  $I_C$  is 10.9A. Typically, the MRF428  $h_{FE}$  is 30-40.

Measured output voltage variations of the bias source (0 — 600mA) are  $\pm 5$  to 7mV, which implies a source impedance of approximately 20 milliohms.

## 300W amplifier

Due to the large emitter periphery of the MRF428, the series base impedance is as low as 0.88 — j0.80 $\Omega$  at 30 MHz. In a

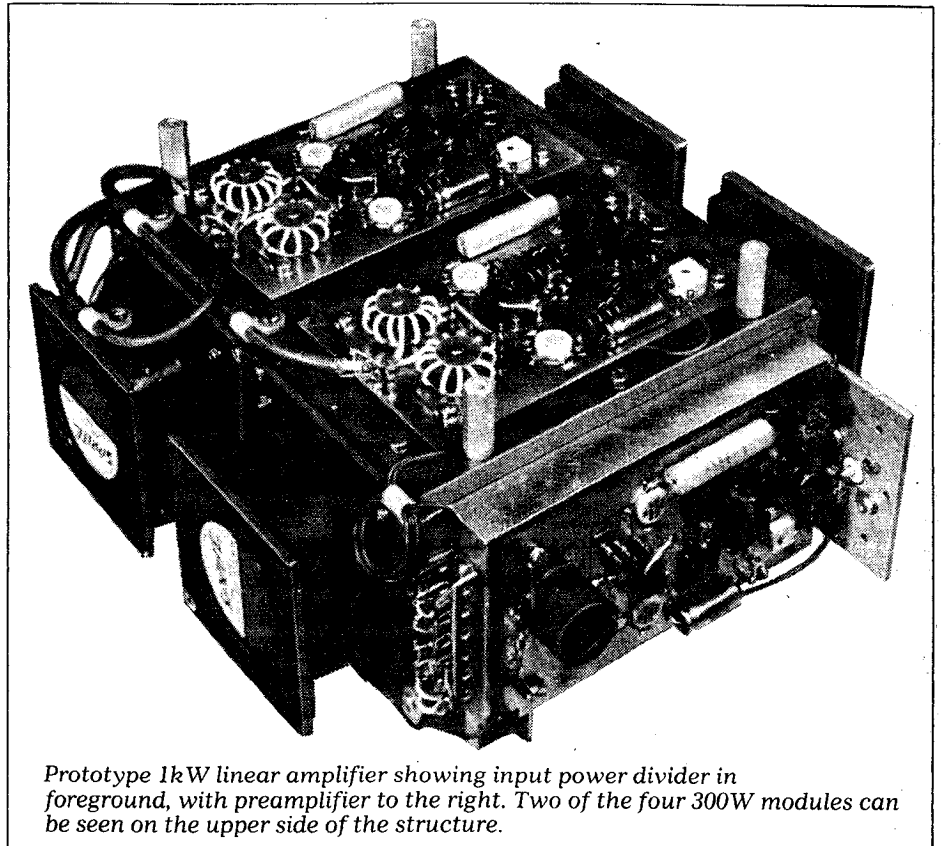

Prototype 1kW linear amplifier showing input power divider in foreground, with preamplifier to the right. Two of the four 300W modules can be seen on the upper side of the structure.

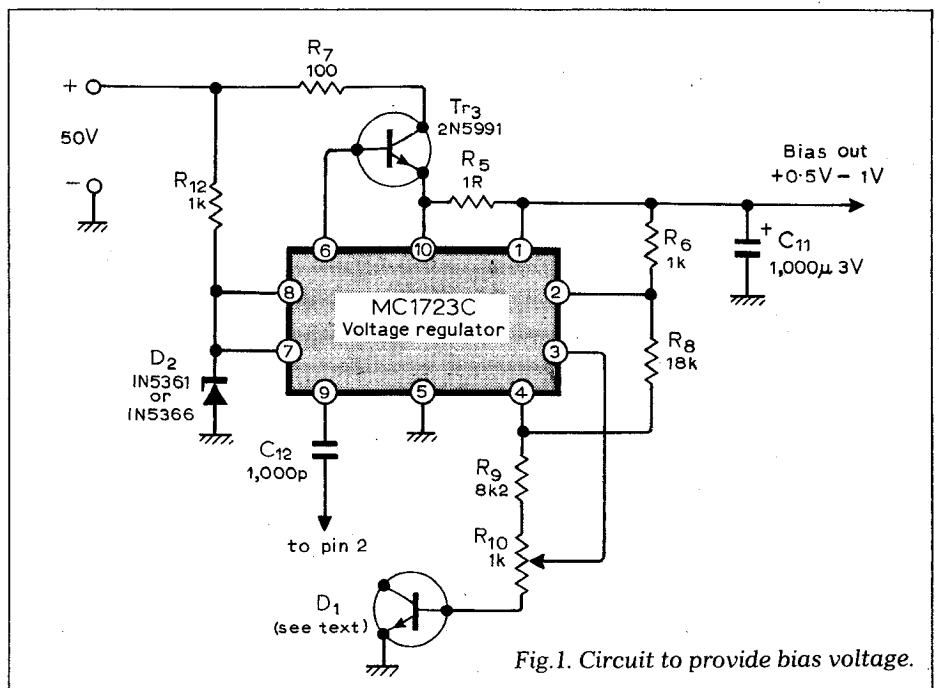

Fig.1. Circuit to provide bias voltage.

push-pull circuit a 16:1 input transformer would provide the best impedance match from a 50Ω source but would result in a high v.s.w.r. at 2 MHz, and would make it difficult to implement the gain-correction network design. For this reason a 9:1 transformer, which is more ideal at the lower frequencies, was chosen. This represents a 5.55Ω base-to-base source impedance.

A centre tap, common in push-pull circuits, is not necessary in the input transformer secondary, if the transistors are balanced. ( $C_{ib}$ ,  $h_{FE}$ ,  $V_{BEF}$ ) The base current return path of the momentarily amplifying transistor is through the base-emitter junction of the momentarily non-amplifying transistor, which acts as a clamping diode, and the power gain is somewhat dependent upon the bias current. The equivalent input circuit of Fig. 2 represents one half of the push-pull circuit, and for calculations  $R_S$  equals the total source impedance ( $R_S'$ ) divided by two.

Since a junction transistor is a current amplifier, it should ideally be driven from a current source which, in r.f. applications, would result in excessive loss of power gain. However, input networks can be designed with frequency slopes having some of the current source characteristics at low frequencies, where excess gain is available.

The complex base input characteristics of a transistor would require a very complicated input compensation network for optimum overall performance. The design goal here was to maintain an input v.s.w.r. of 2:1 or less and a maximum gain variation of  $\pm 1.5$ dB from 2 to 30MHz. Initial calculations indicated that these requirements could be met with a simple RC

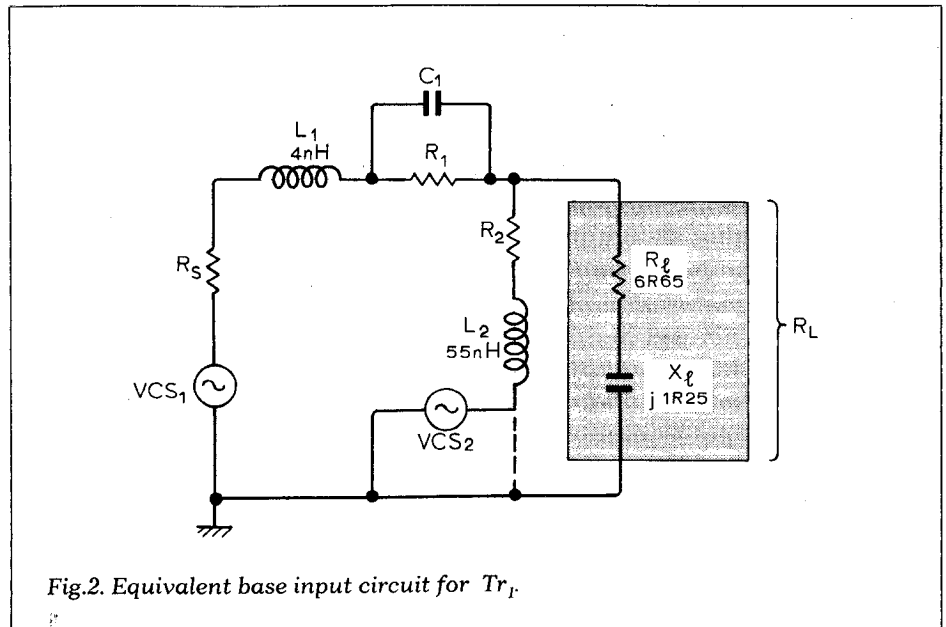

Fig.2. Equivalent base input circuit for  $Tr_1$ .

network in conjunction with negative collector-to-base feedback. Fig. 2 shows this network for one device, where  $L_1$  and  $L_2$  represent lead lengths, their values being fixed. The feedback is provided through  $R_2$  and  $L_2$ . Because the calculations were done without the feedback, this branch is grounded to simulate the operating conditions.

Calculated values of  $R_1$  and  $R_2$  along with other known values and the device input data at four frequencies were used to simulate the network in a computer programme. An estimated arbitrary value of 4000 pF for  $C_1$  was chosen, and  $V_{CS2}$  represents the negative-feedback voltage (Fig. 2). The optimization was done in two separate programmes for  $R_1$ ,  $R_2$ ,  $C_1$  and  $V_{CS2}$  and in several steps. The goals were (a)  $V_{CS}$  and  $R_2$  for a transducer loss of 13 dB at 2 MHz and a

minimum loss at 30 MHz. b)  $R_1$  and  $C_1$  for input v.s.w.r. of <1.1:1 and <2:1 respectively. The optimized values obtained were  $C_1 - 5850$  pF,  $R_2 - 1.3\Omega$ ,  $R_1 - 2.1\Omega$  and  $V_{CS2} - 15V$ . The minimum obtainable transducer loss at 30MHz was 2.3dB, which is partly caused by the highest reflected power at this frequency, and can be reduced by "over-compensation" of the input transformer. This indicates that at the higher frequencies, the source impedance ( $R_S$ ) is effectively decreased, which leaves the input v.s.w.r. highest at 15 MHz.

In the practical circuit the value of  $C_1$  (and  $C_2$ ) was rounded to the nearest standard, or 5600 pF. For each half cycle of operation  $R_2$  and  $R_4$  are in series and the value of each should be  $1.3\Omega/2$  for a  $V_{CS2}$  of 1.5V. Since the voltage across ac

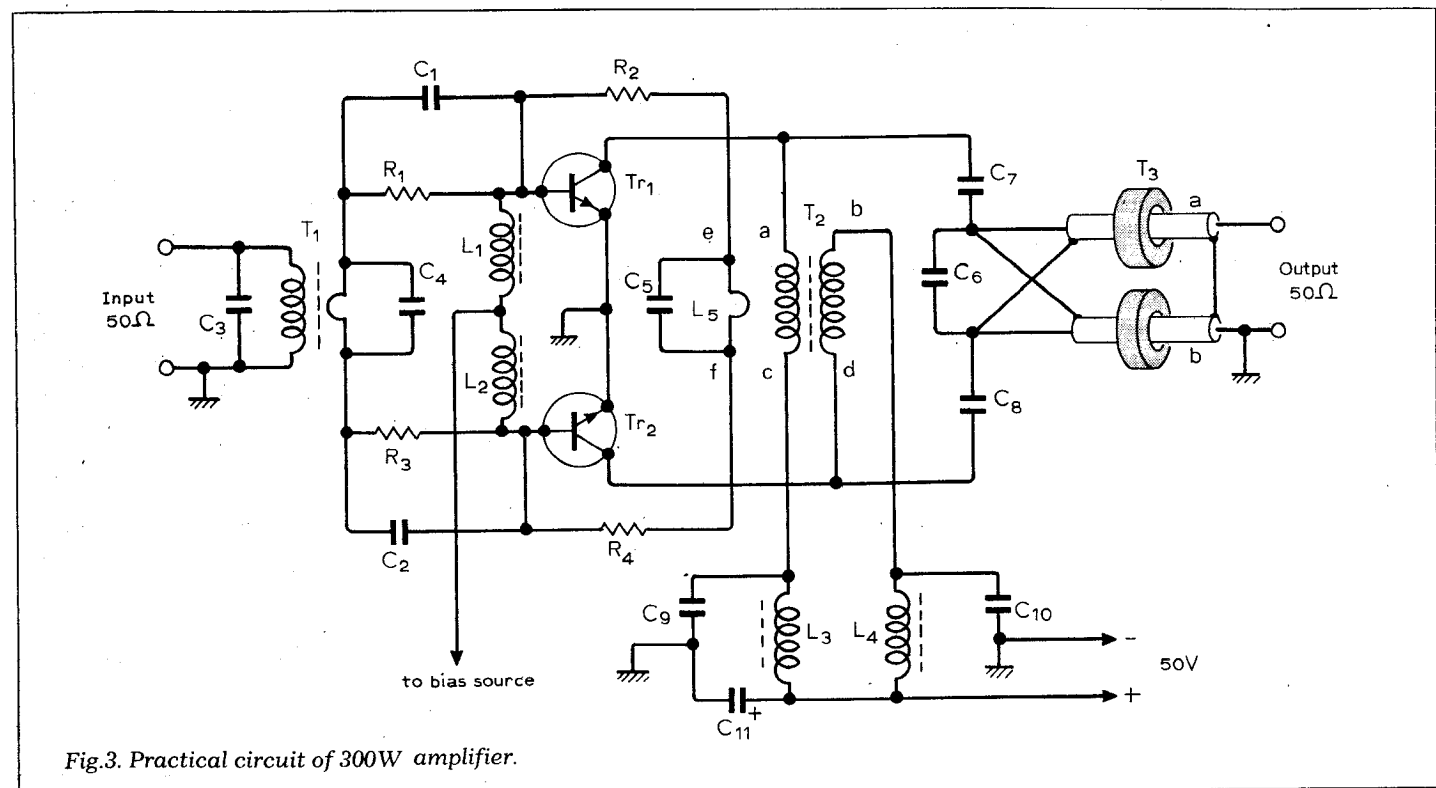

Fig.3. Practical circuit of 300W amplifier.



and  $bd = V_{CE}$ , a turns ratio of 32:1 would be required. It appears that if the feedback voltage on the bases remains unchanged, the ratio of the voltage across  $L_5$  ( $V_{CS2}$ ) and  $R_2R_4$  can be varied with only a small effect to the overall input v.s.w.r. To minimize the resistive losses in the bifilar winding of  $T_2$  in Fig. 3, the highest practical turns ratio should not be much higher than that required for the minimum inductance, which is

$$\frac{4R}{2\pi} = \frac{50}{12.5} = 4.0\mu\text{H},$$

where  $R$  is the collector-to-collector impedance of  $12.5\ \Omega$  and  $f = 2\text{MHz}$ . The inductance of  $ac$  or  $bd$  will then be  $1.0\ \mu\text{H}$ , which amounts to 5 turns. A margin of 25% over this represents a 7:1 ratio, setting  $V_{CS2}$  to 6.9V.

The currents for each half cycle are in opposite phase in  $ac$  and  $bd$  and, depending on the coupling factor between the windings, the even harmonic components will see a much lower impedance than the fundamental. The optimum line impedance for  $ac$ ,  $bd$  would equal the collector-to-collector impedance, but experiments have shown that increasing this number by a factor of 2 to 3 affects the second and fourth harmonic amplitudes by only 1 to 2 dB.

Since the minimum gain loss obtainable at 30 MHz with the network in Fig. 2, and the modified  $V_{CS2}$  source was about  $-3.8\ \text{dB}$  at 30 MHz,  $C_5$  was added to form, with  $L_5$ , a parallel resonant circuit with a  $Q$  of approximately 1.5. Its purpose is to increase the shunting impedance across the bases, and to disturb the  $180^\circ$  phase difference between the input signal and the feedback voltage at the higher frequencies. This reduces the gain loss of 3.8 dB, of which 1.4 dB is caused by the feedback at 30 MHz. The amount depends upon the resonant frequency of  $C_5L_5$ , which should be above the highest operating frequency to avoid possible instabilities.

The input transformer is a 9:1 type, and uses a television aerial balun type ferrite core, made of high permeability material. The low-impedance winding consists of one turn of 1/8in copper braid. The sections which pass through the openings in the ferrite core are rounded to resemble two pieces of tubing electrically. The primary consists of 23 s.w.g. p.t.f.e insulated wire, threaded through the rounded sections of braid, with the primary and secondary leads in opposite ends of the core<sup>1,2</sup>. The saturation flux density is about 60 gauss, which is well below the limits for this type of core.

Several types of output transformer configuration were considered. The  $12.5\ \Omega$  collector-to-collector impedance estimated earlier requires a 4:1 transformer for a  $50\ \Omega$  output. A coaxial cable version was adapted for this design, since the transmission line type transformers are theoretically ideal for r.f.

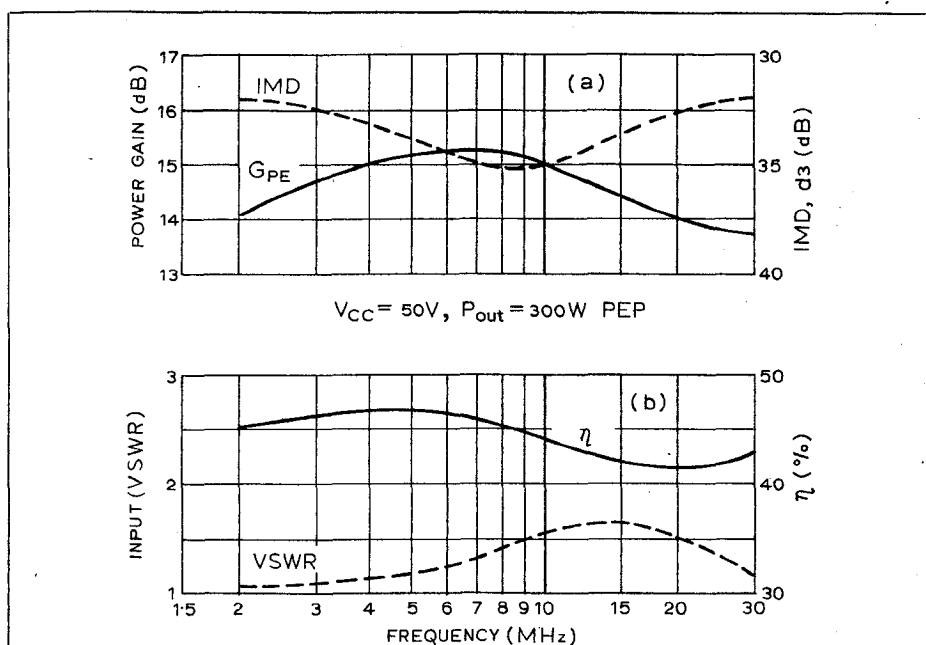

Fig. 4. Intermodulation distortion (3rd) and power gain are shown at (a), while (b) gives input voltage standing-wave ratio and efficiency ( $\eta$ ) against frequency.

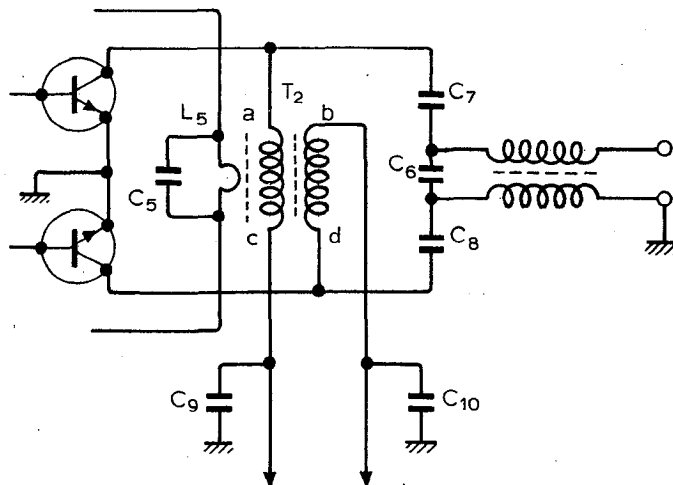

Fig. 5. Driver amplifier for 50W output.

applications, especially in the 1:4 impedance ratio. A balanced-to-unbalanced function would normally require three separate transmission lines including a balun<sup>2,3</sup>, but the third line can be omitted, if lines  $a$  and  $b$  in Fig. 3 are wound on separate magnetic cores, and the physical length of the lines is sufficient to provide the necessary isolation between the collectors and the load. Measurements showed the core losses to be negligible compared to the line losses at 2 MHz and 30MHz. However, the losses increase as the square of  $B_{max}$  at low frequencies.

With the amount of h.f. compensation dependent upon circuit layout and the exact transformer construction, no calculations were made on this aspect for the input (or output) transformers. The values of  $C_3$ ,  $C_4$ , and  $C_6$  were selected by employing adjustable capacitors on a prototype whose values

were then measured. The performance data of the 300W module is shown in Fig. 4.

### Driver amplifier

The driver shown in Fig. 5, uses a pair of MRF 427 devices, and the same circuit board layout as the power amplifier, with the exception of the type of the output transformer.

The input transformer is similar to that used with the power amplifier, but has a 4:1 impedance ratio. The required minimum inductance ( $4\ \mu\text{H}$ ) in the one turn secondary (Fig. 3) being considerably higher in this case, the  $A_L$  product of the core is barely sufficient. The measured inductances between a number of cores range 3.8 –  $4.1\ \mu\text{H}$ .

This formula also applies to the output transformer, which is a 1:1 balun. The required minimum inductance at 2MHz is  $16\ \mu\text{H}$ , amounting to 11

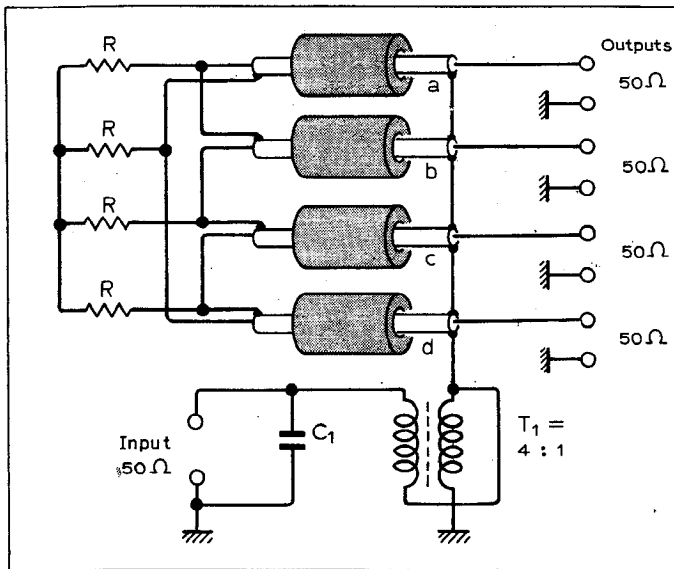

Fig. 6. Four-port input power divider.

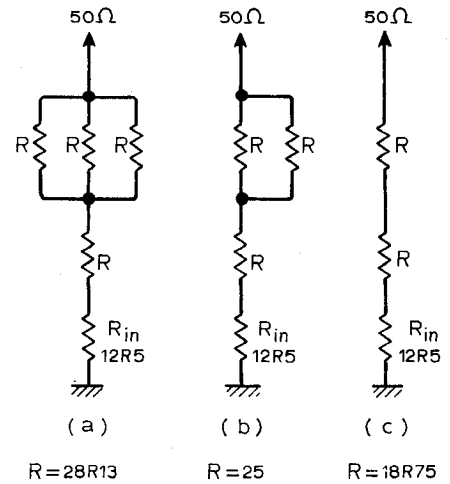

Fig. 7. Balancing resistors R in Fig. 6 when one or more loads open-circuit.

turns on a Ferroxcube 2616P-A100-4C4 pot core.

**Input power divider**

The purpose of the power divider is to divide the input power into four equal sources, providing an amount of isolation between each. The outputs are designed for 50Ω impedance, which sets the common input at 12.5Ω. This requires an additional 4:1 step down transformer to provide a 50Ω load for the driver amplifier. Another requirement is a 0° phase shift between the input and the 50Ω outputs, which can be accomplished with 1:1 balun transformers (a,b,c and d in Fig. 6). For improved low frequency isolation characteristics the line impedance must be increased for the parallel currents. This can be done, without affecting the physical length of the line, by loading the line with magnetic material. In this type of transformer, the currents cancel, making it possible to employ high-permeability ferrite and a relatively short physical length for the transmission lines.

The purpose of the balancing resistors R is to dissipate any excess power if the v.s.w.r. increases. Their optimum values, which are equal, are determined by the number of 50Ω sources assumed unbalanced at one time, and the resistor values are calculated accordingly.

Examining the currents with one load open, it can be seen that the excess power is dissipated in one resistor in series with three parallel resistors, whose total value is  $50 - 12.5 = 37.5\Omega$ . Similarly, if two loads are open, the current flows through one resistor in series with two parallel resistors, totalling 37.5Ω again. This situation is illustrated in Fig. 7.

**Output combiner**

The operation of the output combiner shown in Fig. 8, is the reverse of that of the input power divider. In this application we have four 50Ω inputs and one 12.5Ω output, which is transformed to 50Ω by a 1:4 impedance transformer.

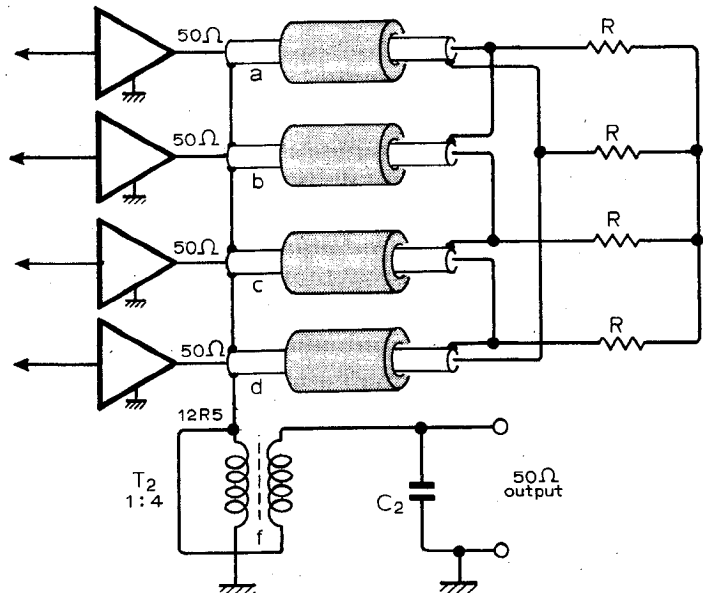

Fig. 8. Circuit of four-port power combiner - the reverse of circuit of Fig. 6.

An arrangement similar to the input power divider is employed in the combiner. The baluns consist of straight pieces of coaxial cable loaded by a sleeve of magnetic material (ferrite). The line length is determined by the physical dimensions of the ferrite sleeves. Straight-line baluns such as these have the advantage over multi-turn toroidal types in introducing a smaller possibility for phase errors, due to the smaller length of the line. The largest possible phase errors occur in the input and output connecting cables, whose lengths are 18in and 10in respectively. All four input and output cables must be of equal length within approximately 1/4in, and the excess in some, caused by the asymmetrical system layout, can be coiled or formed into loops.

The output connecting cables between the power amplifier outputs and the combiner are made of low loss RG-142B/U coaxial cable, that can adequately handle the 300W power with the average current of 2.45A.

The purpose of the step-up trans-

former T<sub>2</sub> is to transform the 12.5Ω impedance from the combiner up to 50Ω. It is a standard 1:4 unbalanced-to-unbalanced transmission line type transformer 3,4,5 in which the line is made of two RG-188 coaxial cables connected in parallel. As in the input transformer, the h.f. compensation (C<sub>2</sub>) was not required.

**References**

1. Granberg, H.: Get 300 Watts PEP Linear Across 2 to 30 MHz From this Push-Pull Amplifier, EB-27, Motorola Semiconductor Products Inc.
2. Granberg, H.: Broadband Transformers and Power Combining Techniques for RF, AN-749, Motorola Semiconductor Products Inc.
3. Hilbers: Design of H.F. Wideband Power Transformer Techniques, Philips Application Information 530.
4. Pizalis-Couse: Broadband Transformer Design for RF Transistor Amplifiers, ECOM-2989, U.S. Army Electronics Command, Fort Monmouth, New Jersey, July 1968.
5. Philips Telecommunication Review, Volume 30, No. 4, pp.137-146, November 1972.

# Power semiconductors — 2

## A survey of devices, technologies and applications

by Mike Sagin *Assistant editor, Wireless World*

Last month's article discussed the group of switching power semiconductor devices known as thyristors. This concluding article looks at power devices which can be used in the linear or switching mode.

### Power transistors

Bipolar junction transistors have been in use since 1948 and, although the early types used germanium, almost all of today's devices are silicon. A power transistor is a current amplifying device whose parameters are dependent upon the structure and geometry. There are four important parameters, voltage breakdown, current gain, speed, and power dissipation, all of which are mutually dependent. This places constraints on the design of a power transistor, and in general the most important parameter is given priority and the others are a compromise.

At low current density, the peak current-gain is determined by the emitter efficiency, base lifetime, and sometimes surface recombination. At high current density, the geometry and base-width are the most important factors. Voltage breakdown is generally proportional to the resistivity or impurity doping concentration on both sides of the junction. Most of the voltage drop occurs on the side of the junction with the lower impurity doping. Power dissipation is restricted by thermal and electrical limitations. Thermal limitation is controlled by the pellet size, thermal capacitance and resistance of the device. Electrical limitation is controlled by the secondary breakdown characteristic. Speed, or transient response, is determined by the capacitance and resistance of the transistor. Junction area and periphery control the capacitance, while doping and thickness of the active regions control the resistivity.

Because of the various trade-offs that exist in power transistors, several different structures have been developed.

**Single diffused**, sometimes called homotaxial-base, transistors — Fig. 20 start with a wafer of moderately high

resistivity silicon which then has several thin layers of impurities deposited and diffused deeply into both sides. Early in this diffusion process the top of the wafer is etched to produce a plateau which becomes the emitter area. This raised area is called a mesa. The process is completed when the deeply-diffused junctions are separated by a base region of about 25 micro-metres.

The single diffused process produces a very rugged device which has a high safe operating area (s.o.a.). The wide

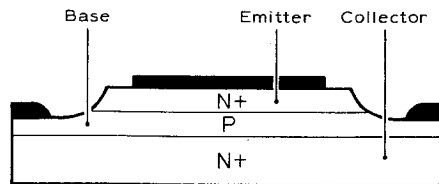

Fig.20. Single-diffused structure.

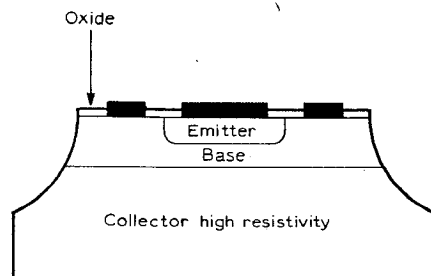

Fig.21. Double-diffused mesa structure.

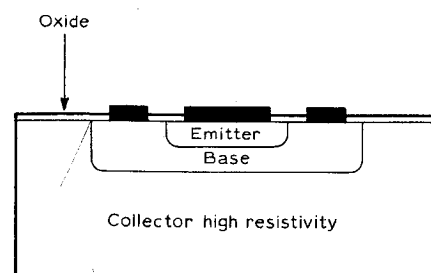

Fig.22. Double-diffused planar structure. Because the collector base junction terminates at the surface of the wafer it can be protected by an oxide layer.

undiffused base region, called homogeneous, allows injected charge carriers to spread out and reduce the charge carrier density at the collector junction where most of the heating takes place. The wide base region does, however, restrict the maximum  $f_T$  to around 2MHz. Large batch processing allows these devices to be manufactured cheaply although only n-p-n varieties can be produced. Maximum ratings for single diffused transistors are  $V_{CEO}$  of around 200V and continuous  $I_C$  of about 30A.

**Double diffused mesa transistors** — Fig. 21 start with a moderately high resistivity silicon wafer which has a dopant impurity deposited and then diffused to a shallow depth. Silicon dioxide is selectively etched to define regions where the emitter impurity is to be deposited and diffused. The oxide forms a mask which causes the emitter to diffuse more rapidly than the base. This action provides a narrow base region. Double diffused structures have the high-resistivity side of the collector-base junction on the collector side. As a result, the collector voltage can be designed almost independently of the base width.

The narrow nonhomogenous base provides an  $f_T$  up to around 20MHz but the base is also more fragile which reduces the s.o.a. The thick high-resistivity collector region also produces a high saturation resistance.

**Double diffused planar transistors** — Fig. 22 are very similar to the mesa type except for the collector-base junction. An additional selective mask is used for the base impurities which terminates the collector-base junction at the surface of the wafer instead of on the side. This junction is therefore passivated by a protective oxide layer as is the base-emitter junction in the mesa structure.

The planar transistor offers a greatly reduced collector leakage current and more predictable device characteristics. Disadvantages are similar to those of the mesa type but the planar structure also has a collector voltage capability

which is up to 20% lower than a comparable mesa type. Again, only n-p-n devices are available.

**Triple-diffused transistors** — Fig. 23 are similar to double-diffused devices except for a third diffusion on the opposite side of the silicon wafer. This eliminates the high saturation resis-

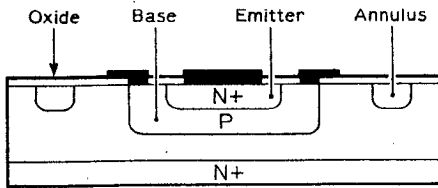

Fig. 23. Triple-diffused planar structure.

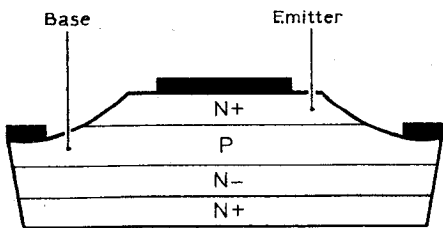
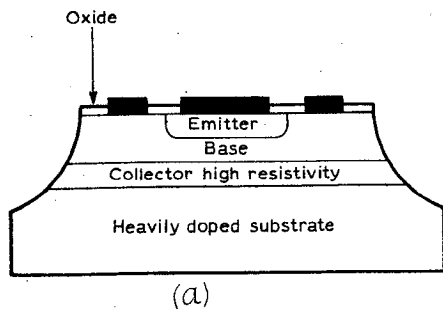
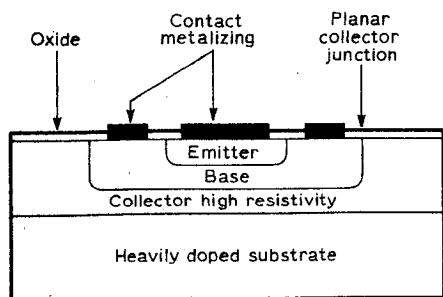

Fig. 24. Triple-diffused etch cut. This is a variation of the standard triple diffused device which offers a much higher  $V_{CEO}$  rating.



(a)



(b)

Fig. 25. (a) Double-diffused epitaxial mesa structure, (b) planar structure.

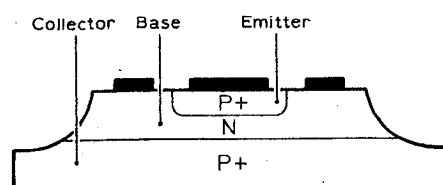

Fig. 26. Epitaxial-base mesa structure.

tance. The structure shown in Fig. 23 is the planar version and, like the double diffused, a mesa structure is also available. Devices with  $f_T$  ratings up to 30MHz,  $V_{CEO}$  ratings around 400V and continuous  $I_C$  ratings up to 15A are possible. Because the high-resistivity collector region is narrowed by a third diffusion, and the bulk of the collector is heavily doped and highly conductive, the junction is very fragile which greatly reduces the s.o.a. As with previous diffused devices, only n-p-n types are available.

A variation of this structure is the triple-diffused etch-cut device from Motorola — Fig. 24. This produces transistors with  $V_{CEO}$  ratings of up to 1000V, and continuous  $I_C$  ratings up to 15A. The  $h_{fe}$  rating is normally reduced together with the  $f_T$ , up to 10MHz, but the s.o.a. is slightly increased. Only n-p-n devices are available.

**Double-diffused epitaxial transistors** — Fig. 25 (a) and (b) are similar in appearance to the triple-diffused types, except that the diffused collector region is replaced by a heavily doped homogeneous layer referred to as the epitaxial substrate. A difference in doping produces improvements in the  $f_T$  up to 100MHz, and saturation resistance. However, the s.o.a. is very low and this type of device is unsuitable for driving capacitive or inductive loads. Both mesa and planar structures are available with  $V_{CEO}$  ratings up to around 300V and continuous  $I_C$  ratings up to 50A. Unlike the normal diffused transistors, both n-p-n and p-n-p types are available.

**Epitaxial-base mesa transistors** — Fig. 26 use epitaxial layers in the actual formation of the base-collector junction. A layer of impurity is epitaxially grown, rather than diffused, on to an opposite polarity and highly doped substrate. Oxide masking and emitter diffusion into this epitaxial layer completes the construction. The main

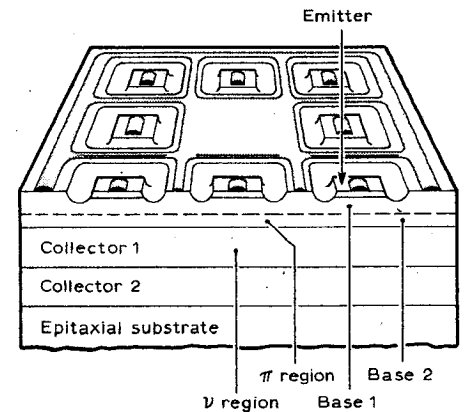

Fig. 27. Multiple epitaxial base mesa structure.

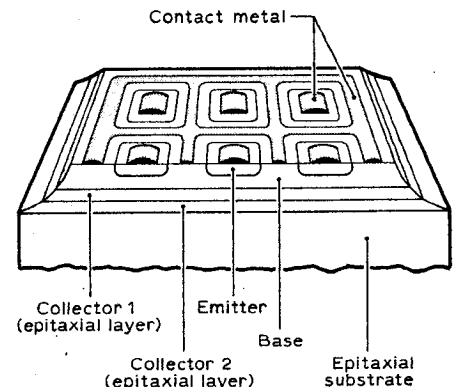

Fig. 28. Multiple-epitaxial double-diffused mesa structure.

advantage of the epitaxial-base structure is its ruggedness and s.o.a.

The epitaxial-base mesa transistor also has a higher frequency response, up to 10MHz, and the ability to carry higher currents for an equivalent emitter area. Maximum  $V_{CEO}$  ratings are around 160V with continuous  $I_C$  ratings up to 50A. The disadvantage of this design is the low voltage limitation which is due to the abrupt base-collector junction formed between the heavily doped collector substrate and the

Table 3. Silicon power transistor structures and trade-offs

| Structure                               | Advantages  | Disadvantages                   |
|---|---|---------------------------------|
| Single diffused (hometaxial-base)       | Rugged, low cost  | Low speed                       |
| Double-diffused mesa                    | High speed  | High saturation resistance      |
| Double-diffused planar                  | High speed, low leakage   | High saturation resistance      |
| Triple-diffused                         | High Speed, low saturation resistance                           | Moderate cost, moderate leakage |
| Triple-diffused etch cut                | High voltage  | Moderate speed                  |
| Double-diffused epitaxial mesa          | High speed, low saturation resistance                           | Moderate cost, moderate leakage |
| Double-diffused epitaxial planar        | High speed, low leakage, low saturation resistance              | Higher cost, less rugged        |
| Epitaxial-base mesa                     | Moderate speed, low saturation resistance, moderately rugged    | Low voltage, moderate leakage   |
| Multiple epitaxial base mesa            | Moderate speed, low saturation resistance, rugged, high voltage | Moderate cost                   |
| Double-diffused multiple-epitaxial mesa | High speed, rugged, low saturation resistance                   | Moderate cost, moderate leakage |

epitaxially deposited base layer. A second disadvantage is the moderate collector leakage-current resulting from the mesa construction. Both n-p-n and p-n-p devices are available.

**Multiple-epitaxial base transistors** —

Fig. 27 are similar to the epitaxial base devices except for an added high-resistivity epitaxial layer for the active collector region. The transistor is constructed from a heavily doped silicon wafer on which alternate layers of p-n or n-p high resistivity silicon are epitaxially grown to create a  $\pi$ -v or v- $\pi$  base-collector junction. An emitter area is then diffused into the structure.

The main advantages of this construction are high voltage ratings and good current carrying abilities together with an improved s.o.a. The higher voltage ratings are due to the base and collector regions which both support the applied collector voltage. Good current ratings are due to the lower collector resistivity. The moderately wide base region and partial homogenous base doping, which spreads the charge carrier density, provides good secondary breakdown characteristics. The main disadvantage of this construction is the relatively high manufacturing cost.

**Multiple-epitaxial double-diffused mesa transistors** —

Fig. 28 are similar to the double-diffused epitaxial types except that multiple epitaxial layers are used in the collector region. The top collector is a thin highly resistive layer followed by one or more thin heavily doped layers. These layers are grown sequentially onto a thick and heavily doped silicon substrate wafer. Advantages of this process are high speed, low saturation resistance, higher collector-junction voltage ratings and an increased s.o.a. Disadvantages are high cost and moderate leakage in the structure.

The types of structures already discussed are summarized in Table 3 with advantages and disadvantages. Performance curves for five popular types of device are shown in Fig. 29.

The geometry of a transistor can be considered as its topography. This together with the structure defines most of the fundamental properties. Most geometry designs in power transistors are aimed at increasing the current handling per unit area of device. The diagrams in Fig. 30 show various configurations from the inefficient ring-dot format to a present day overlay system. The recent interdigitated and overlay-geometries greatly increase the emitter periphery which in turn reduces high current density. This reduction in current crowding effectively increases the current gain of the device.

Two general methods exist for connecting the ohmic portion of the emitter and base contacts to the external leads of the package. Either wire bonds or soldered contact clips are used and Table 4 shows a range of connections.

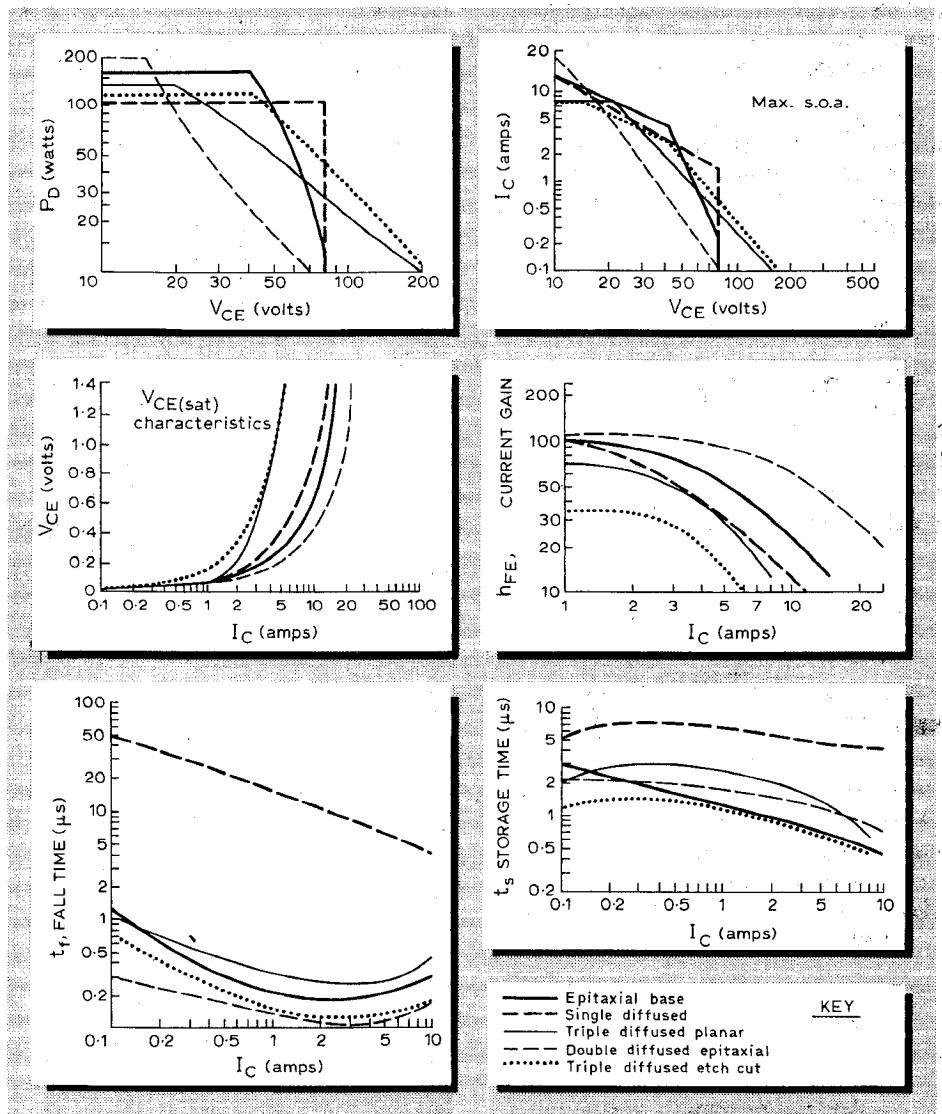

Fig. 29. Performance curves for five different transistor structures.

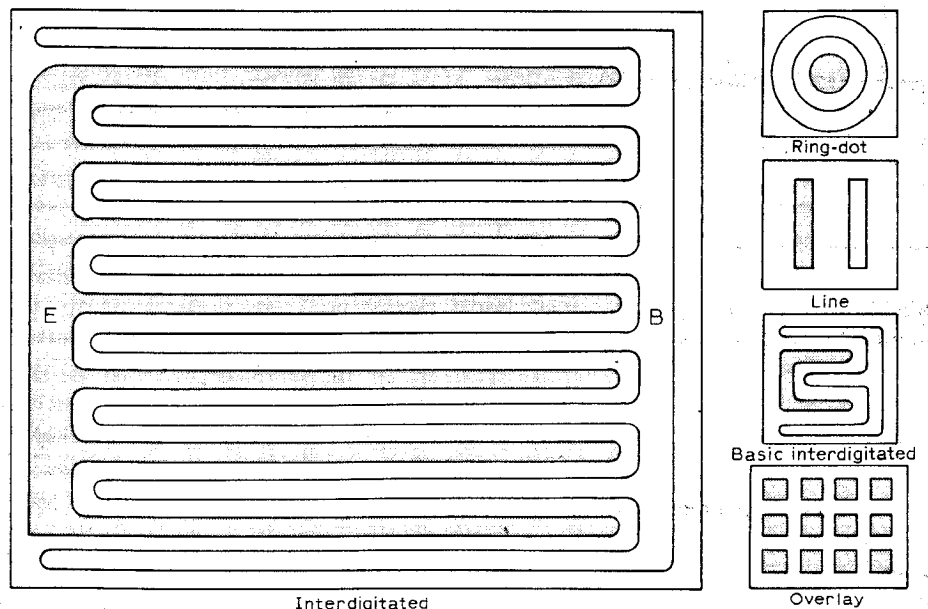

Fig. 30. Various transistor geometries.



**Table 4. Methods of lead attachment**

|                    |                               |                           |  |                              |
|--------------------|-------------------------------|---------------------------|--|------------------------------|
| Thermo-compression | High temperature and pressure | Gold-wire ribbon          | Very small areas                                   | Costly in large devices      |
| Nailhead bond      | High temperature and pressure | Gold wire with end balled | Stronger than thermo-compression bond, less costly | Larger contact area required |
| Ultrasonic bond    | Ultrasonic weld               | Aluminium or gold wire    | Avoids gold-alum problems                          | Costly in large devices      |
| Wire solder        | Insert wire in molten solder  | Suitable solderable wires | Moderate cost                                      | Large contact area required  |
| Clip solder        | Pre-set into clips; solder    | Phosphor-bronze or nickel | Low cost   | Large contact areas required |

**Darlington transistors**

The Darlington pair is a well-known current-gain configuration which uses two transistors and one or two passive components. A relatively new device is the monolithic power Darlington which combines these components on one chip. The structure and equivalent circuit of such a device is shown in Fig. 31. This particular structure uses a double-epitaxial, single-diffused process where the collector consists of an n<sup>+</sup> substrate plus an epitaxially grown n-type layer. The p-type base is epitaxially grown on top of the substrate, and the n-type emitter impurities are diffused into the base. For p-n-p versions the structure is similar. Construction of such a power Darlington is essentially the same as an epitaxial single-diffused transistor. The geometry, however, is very different. The driver transistor in the structure of Fig. 31 is in the centre of the pellet and is surrounded by the output transistor. The base emitter connection of the two devices is formed by metallization on the surface of the pellet.

Although monolithic Darlington pairs have not been in existence for many years, some awesome devices are currently being produced. Toshiba have introduced a range of switching devices, one of which can handle a current of 400A at 300V and dissipate a staggering 3000W while offering a h<sub>fe</sub> of 100 and a turn on time of 1μs. This sort of device is intended to replace thyristors in the control of d.c. motors.

Most Darlington structures have an integral diode connected across the output collector and emitter. The diode forward voltage drop is designed to be

less than the rated V<sub>EB0</sub> and can be useful as an emitter clamp. A new device from Texas, the BU180/A, also has an integral speed-up diode connected between the base and emitter of

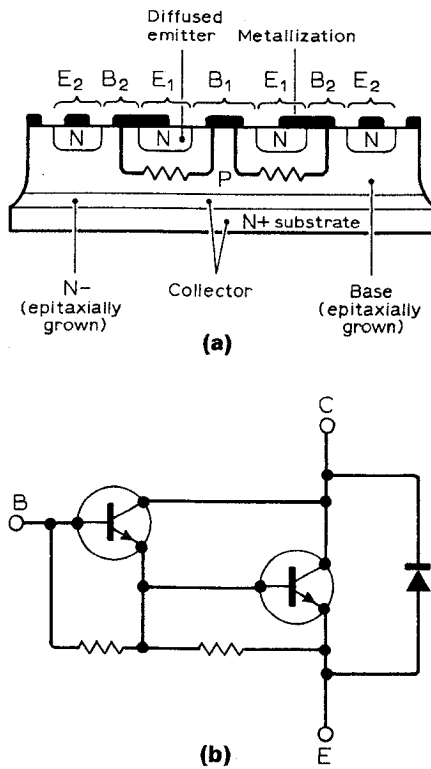
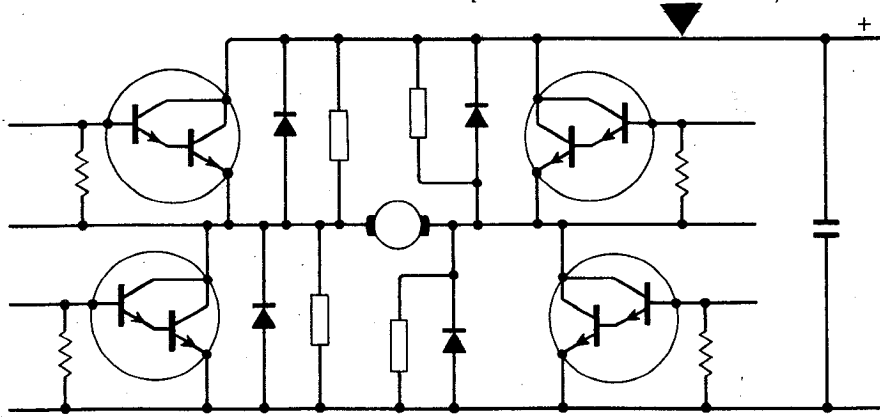

Fig.31. (a) Monolithic power Darlington structure, (b) equivalent circuit.

Fig. 32. Power Darlington bridge used to replace conventional thyristor motor-drive circuit. Each transistor has a high speed rectifier and surge suppressor across the collector/emitter.



the driver transistor. This type of device has been designed to compete with medium and high power thyristors in d.c. applications. Faster devices are also being developed to compete with conventional low-gain power switching transistors.

**Power f.e.t.s**

Over the last three years f.e.t.s have challenged conventional bipolar power devices. Advantages of these f.e.t.s include high input impedance, greater linearity, majority carriers as opposed to minority carriers in bipolar devices, fast switching, and a negative temperature coefficient for the drain current. The last mentioned prevents secondary breakdown and provides an inherently short-circuit proof device when used in the output of an amplifier.

Although there are only two main types of power field-effect transistor available at the moment, much confusion has arisen from the use of loose terminology. The current "buzz" word is "V" f.e.t.s which has been used to describe either the vertical current flow within the device, the physical V shaped groove in the device, or both. The most publicised f.e.t.s at present are the Japanese devices, first reported in *Wireless World* July 74 and July 76. These are vertical-junction depletion-mode (normally on) f.e.t.s and are currently being used in audio equipment. Six devices from the three manufacturers are shown in table 5, and Fig. 33(a) shows a simplified construction. Current flows vertically from the substrate through the chip, which measures about 3x3mm, and allows a greater current density for high power applications. This type of construction permits the production of complementary pairs. Output characteristics of these devices are very similar to a triode valve. One disadvantage of this construction is the relatively high capacitance (C<sub>ISS</sub>), around 700pF for the NEC type and 3000pF for the Yamaha, which limits the upper frequency response. Also, when used in linear amplifiers, several different supply voltages are necessary. Because the devices are

**Table 5 Power ratings of commercial vertical junction f.e.t.s**

| Nippon Electric | Sony        | Yamaha      |
|-----------------|-------------|-------------|
| 2SK70 2SJ20     | 2SK60 2SJ18 | 2SK75 2SK77 |
| n channel       | n channel   | n channel   |
| 100W at 25°C    | 63W at 25°C | 20W 200W    |
| --              | 170V        | 200V 200V   |
| --              | 5A          | 0.5A 20A    |

normally on, a gate bias has to be applied before power is supplied to the output stage. Conversely, power has to be removed from the output stage before the gate bias.

Up to date these devices have only been commercially used in linear hi-fi equipment but in a recent paper presented at the 55th AES Convention, Mr T. Suzuki of the Sony Corporation outlined the design of a pulse-width modulation audio power amplifier using vertical junction f.e.t.s.

Although these f.e.t.s are better suited to low frequency application, future devices will offer lower saturation resistances by using larger chip sizes, and higher amplification factors.

Power m.o.s.f.e.t.s, commonly called v.m.o.s, are the second group of devices and several companies are developing this technology. At present most of the devices are lower power than junction f.e.t.s, but offer faster switching speeds. American Microsystems and Electronic Arrays are developing v.m.o.s structures — see Fig. 33(b) for use in r.o.ms, r.a.ms and possibly microprocessors. Westinghouse Research Centre have experimented with "shadow mask" gate metallization in the structure shown in Fig. 33(c). The overhanging oxide layer forms an aperture through which the gate metallization is sputtered over the channel. This process has been used to produce microwave devices which exhibit an  $F_T$  of 4.8GHz, but there are no commercial products available yet.

Harris Semiconductor have developed a 12W device using the structure shown in Fig. 33(d). This offers depletion mode performance and is called v.m.o.s. because of the groove and not the current path. Hitachi have produced a v.m.o.s. device without the groove, see Fig. 33(e). Current flow is again vertical but a polysilicon gate is used and this allows a high packing density but limits the high frequency performance to 1MHz. By using a large geometry size of 5x5mm, the device has an 80V 20A capability and is aimed at the high fidelity market as an alternative to the vertical-junction f.e.t.s. Siliconix have commercially available a range of v.m.o.s. devices under the trade mark MOSPOWER. These f.e.t.s are based on the structure in Fig. 33(f). The n+ substrate becomes the drain and an n- epilayer increases the drain-source breakdown voltage by absorbing the depletion region from the drain p-body junction which is normally reversed biased. Because the gate overlaps n- instead of n+ material, the feedback capacitance is reduced by the epilayer. A p- body and n+ source are then diffused into the epilayer, similar to the base and emitter diffusions in a bipolar transistor. A V groove is then etched through the source body and into the n- epilayer. Oxide is grown, followed by the deposition of an aluminium gate. The completed chip is then passivated. In operation the gate is taken positive with respect to the source. The resulting

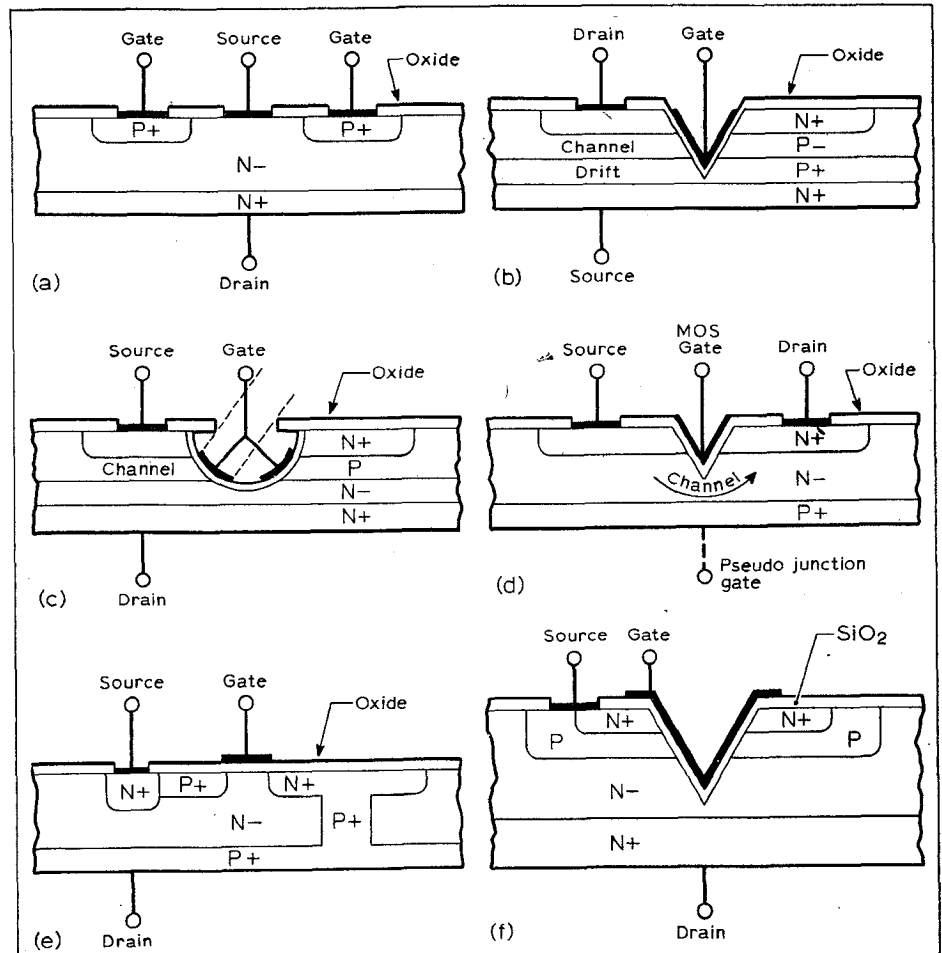

Fig. 33 Various-power f.e.t. structures under development and in production.

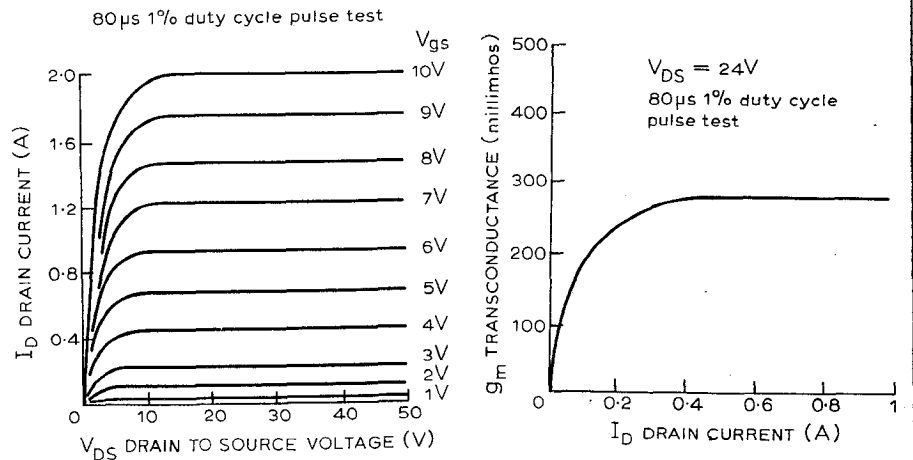

Fig. 34 Output characteristics of a typical v.m.o.s. field effect transistor.

electric field induces an n-type channel on both surfaces of the body facing the gate. Electrons can then flow directly from the source through the n-type channel and epilayer into the drain.

The V groove structure offers several advantages over conventional m.o.s. devices. The length of the channel is determined by diffusion depths which are much more controllable than the mask spacings used to define the channel length in standard low power devices. The substrate forms the drain contact, so drain metal runs are not required on top of the chip. This reduces chip area and keeps the saturation

resistance low. Because the groove creates two channels the current density is doubled, which also keeps the chip capacitance low.

Output characteristics of a typical device are shown in Fig. 34. Because of the extremely fast switching time, 1 amp in 4ns, and typical on resistance of around 3Ω, these f.e.t.s can be used in converter, r.f., and switching regulator circuits. Although the maximum dissipation is around 25W at 25°C several devices can be used in parallel operation as shown in Fig. 35. This practical audio amplifier circuit will deliver around 40W continuous into 8Ω. As the f.e.t.s

Fig. 35. Practical audio amplifier using six v.m.o.s. f.e.t.s in the output stage. The circuit has a bandwidth of 800kHz and a typical distortion content at 1kHz 40W, of 0.04%. Resistors  $R_{16}$  to  $R_{18}$  and  $R_{21}$  to  $R_{23}$  should be connected to within one inch of

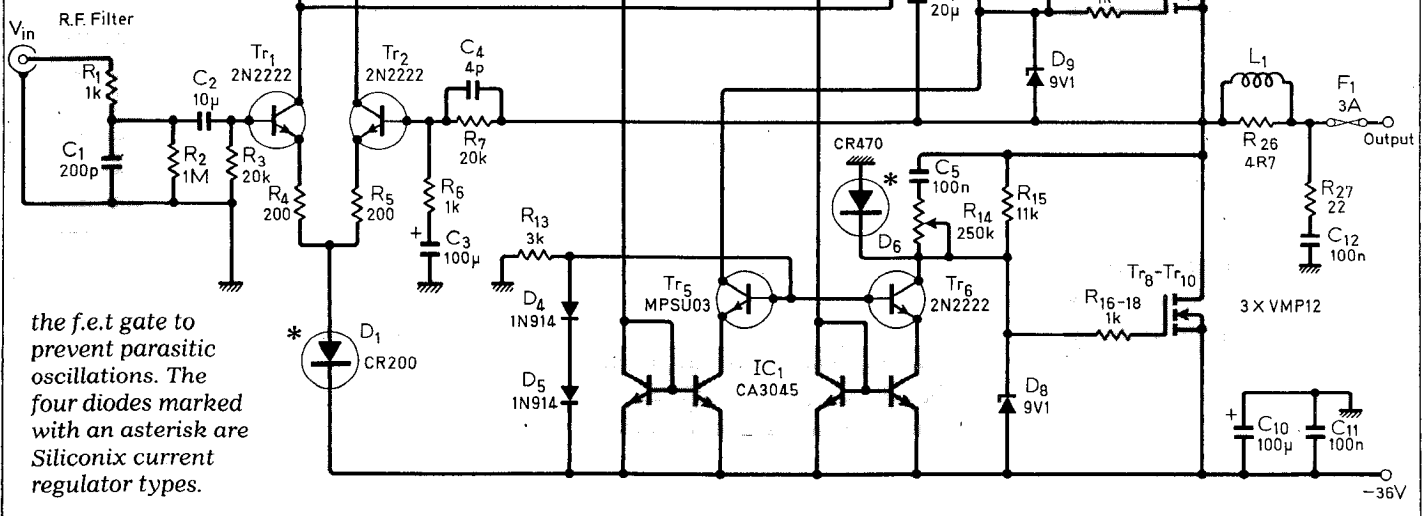

the f.e.t gate to prevent parasitic oscillations. The four diodes marked with an asterisk are Siliconix current regulator types.

are enhancement mode (normally off) only one split power supply is needed. The circuit has a bandwidth from 1Hz to 800kHz, a typical distortion figure of

0.04% at 1kHz 40W, and the output is short circuit proof due to the negative temperature coefficient.

The future of v.m.o.s. devices seems

well assured especially as Siliconix are talking about transistors with 10A, 200V capabilities, and on-resistances of below one ohm.

#### ● continued from page 66

communicated not counting voice channels.

I.L.S. has a limited number of channels, and some airports do not have suitable ground sites for the equipment. It is also susceptible to severe multipath interference, scattering and diffractions from buildings, geographical features and moving aircraft. Aircraft must land one at a time.

The ideal ICAO-approved m.l.s. system will have left-right guidance up to 30 miles away, two elevation aeriels providing "coarse" and "fine" height information, and a back azimuth beam to guide aircraft that overshoot. The information will be available over a much wider area than can currently be provided by the thin i.l.s. beam, and thus it will be within the range of more than one aircraft at a time.

In addition, the ICAO wants to move towards making it possible to use the landing system when visibility is zero. At the moment the category 3(a) standard applying to most major airports provides for landing with an external visual reference of 200m. Category 3(b) is defined with a visual range of 50m. The zero range is category 3(c).

Following the setting up of a committee in 1967, when about 50 microwave landing systems were competing, the decision to base future systems on microwaves was taken about five years ago. Broadly, the choice is between two, the American and the British, though both sides have changed their proposals frequently in a way reminiscent of the surround-sound battle in audio systems. The British system was devised by Charles Earp of Standard Telephone Laboratories, Harlow, in 1968. He thought that if a fixed frequency r.f. signal were moved back and forth perpendicular to ideal path down the centre of the runway, a plane approaching at a wrong angle would observe a change in its frequency, a Doppler shift, proportional to the sine of the angle the plane's path made with the correct approach. Any Doppler shift caused by the movement of the plane could be compensated by an additional stationary reference beam at the same frequency.

A horizontal Doppler beam would provide the azimuth, and a vertical one the approach angle. In a practical system the moving source could be replaced with a switched series of

stationary sources. The British proposal is now being put forward by Plessey, for whom STL are now subcontractors.

The American system, the time-reference scanning beam (t.r.s.b.) devised by Bendix, works by sending out two fan-shaped beams which scan through predetermined angles. One beam provides azimuth and the other elevation information. During each scan, the aircraft receives two pulses, one each during the to and fro scans. The position angle of the aircraft is determined by the time differences between these pulses; since the aircraft will only receive them at equal intervals if it is directly on course. A third "flare" transmitter provides the low-angle guidance needed in the last half mile before touchdown.

In the voting in Montreal Britain was supported by Dutch and Canadian delegates and the representatives of the International Federation of Airline Pilots' Associations. The US system was supported by a formidable alliance of Russia, Australia and the International Air Transport Association, for the airlines. The ICAO navigation committee is expected to meet in the autumn.

# Circuit Ideas

## Op-amp power output stage

This circuit overcomes the difficulty in setting quiescent current by using  $R_2$  for adjustment and  $R_3$ , within the feedback loop of the op-amp, for stabilization.

Positive signals are handled by  $Tr_1$  with base current flowing down  $L_1$ . Negative signals are handled by  $Tr_2$  with base current initially via  $R_1$ . For large negative signals  $D_1$  becomes forward biased and base current for  $Tr_2$  is then drawn through the load and  $D_1$ . Resistor  $R_1$  must be large enough to forward bias  $D_1$  for negative excursions in order to prevent  $Tr_1$  from being turned on. It is possible to omit  $R_1$ ,  $C_4$  and  $R_3$ , but the crossovers are then less smooth. The op-amp may be used in the virtual earth mode if desired.

D. Rawson-Harris,  
Ferranti Ltd,  
Manchester.

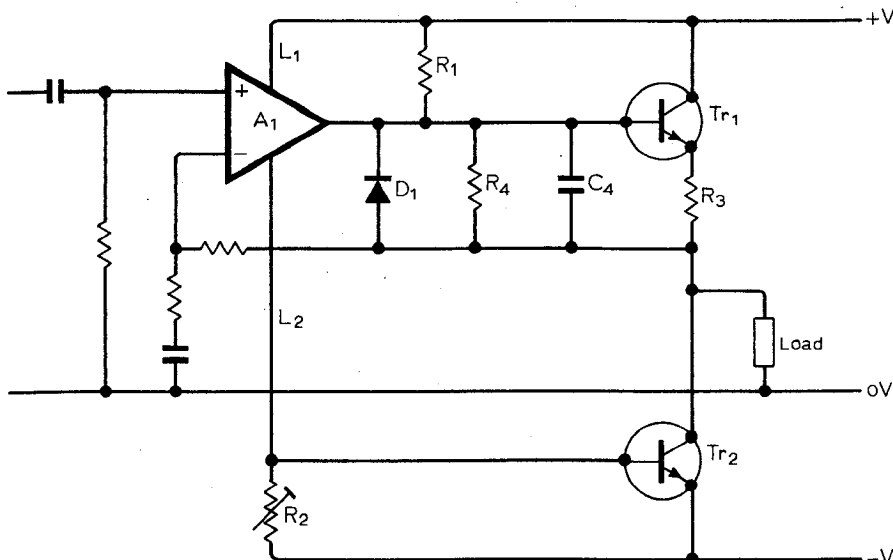

## Zero crossing detection with exponentially decaying hysteresis

It is well known that a zero detector may be constructed as shown in Fig. 1. Assuming that the output  $V_0$  of the operational amplifier is at its positive limit  $V_+$ , then the voltage  $V_+$  on the non-inverting input is  $V_1 R_2 / (R_1 + R_2)$ , and the amplifier output will not change

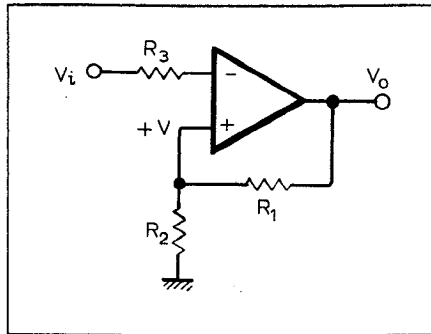

Fig 1

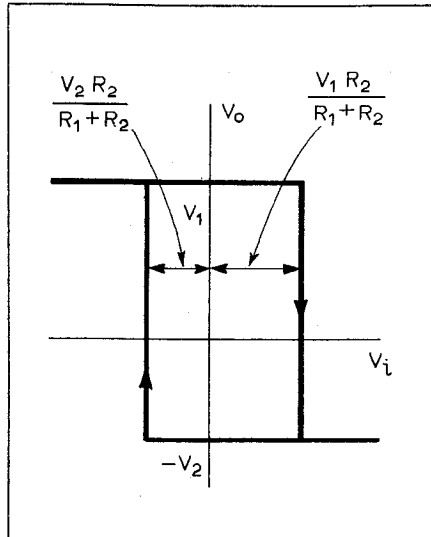

Fig 2

unless  $V_i > V_+$ . Once  $V_0$  starts to fall,  $V_+$  decreases and the switching process is accelerated due to positive feedback through  $R_1$ . The penalty for this sharp switching is that when  $V_0$  is at its negative limit  $-V_2$ , the amplifier will not start to switch unless  $V_i < -V_2 R_2 / (R_1 + R_2)$  and thus exhibits a hysteresis band of width  $(V_1 + V_2) R_2 / (R_1 + R_2)$  as shown in Fig. 2. This hysteresis is often valuable because it avoids multiple switching of the detector when the input consists of a low frequency signal corrupted with high frequency noise. It does, however, reduce detector sensitivity for small inputs.

The modified circuit shown in Fig. 3 gives improved zero detection. When the circuit changes state,  $V_0$  changes by an amount  $(V_1 + V_2)$  and thus  $V_+$  immediately changes by  $(V_1 + V_2) R_2 / (R_1 + R_2)$ , because the charge on the capacitor cannot change instantaneously. Subsequently,  $V_+$  decays exponentially to zero with time constant  $(R_1 + R_2)C$ . Since  $V_0$  only

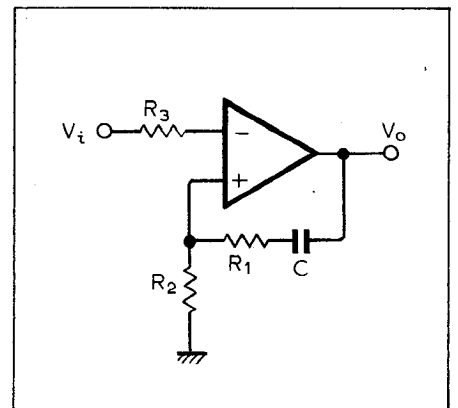

Fig 3

changes when  $V_i = V_+$  the hysteresis in the detector is large just after a change of state has occurred, but later decays to zero. Therefore, there is sharp switching between the limits and when noise is present multiple switching is avoided. If the time constant is significantly shorter than the average time separation of the zero crossings the zero detection is very accurate.

To avoid error with the input bias currents of the amplifier,  $R_3 = R_1 R_2 / (R_1 + R_2)$  in Fig. 1 and  $R_3 = R_2$  in Fig. 3. Also in Fig. 3  $R_1 > R_2$  so that the input-voltage limits of the operational amplifier are not exceeded.

M. L. Bransby,  
University of Sheffield.

Contributors to Circuit Ideas are urged to say what is new or improved about their circuit early in the item, preferably in the first sentence.

### Linear v-f converter

In this circuit a NE556 timer is used in a dual mode. Frequency of operation is  $0.91/2RC$  where R is the resistance of the f.e.t. Because the resistance R is indirectly proportional to the input voltage, the circuit is very linear. Frequency range is from 0.1Hz to 100kHz and the linearity is within 0.005%.

Kamil Kraus,  
Rokycany,  
Czechoslovakia.

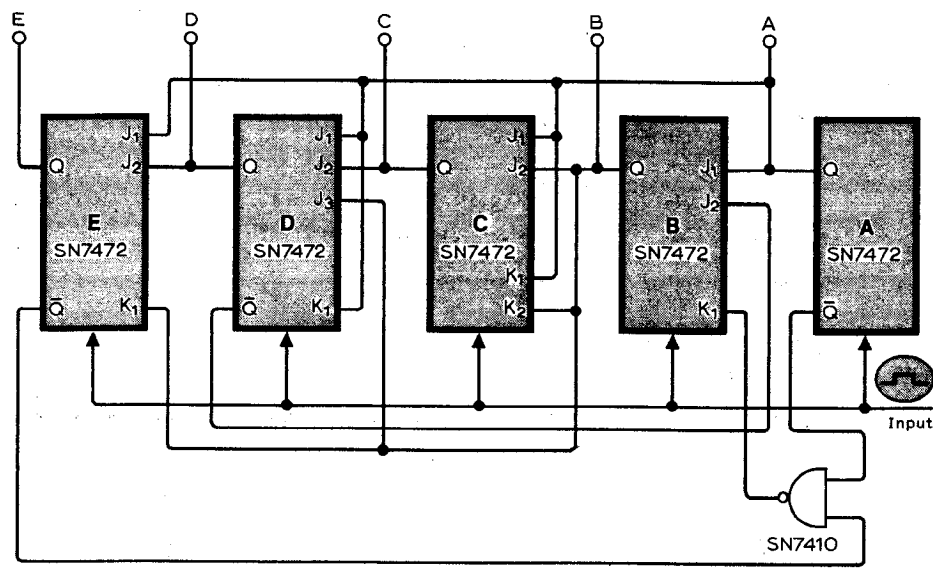
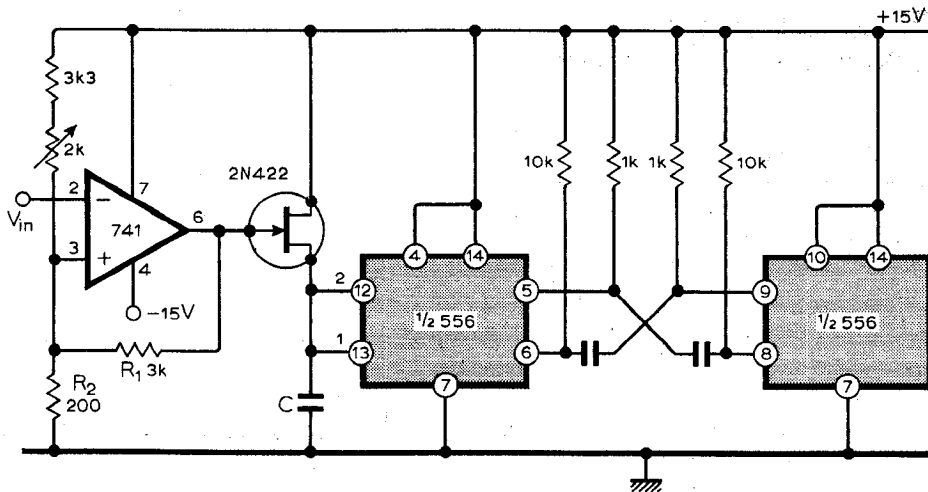

### True count-by-twelve circuit

An ordinary divide-by-twelve circuit gives a logical sequence of output states that go from zero to eleven, whereas a true count-by-twelve circuit will do so from the count 1 through 12 and will come back to 1 with no zero. One application of such a circuit is in a 12-hour digital clock. The design is fairly straight-forward and relies on the truth table of the J-K flip-flop. On resetting, all the outputs go to logical zero but, on clocking, the zero state does not recur.

Ijazur Rehman,  
University of Islamabad,  
Pakistan.

### Speech compressor/limiter

This simple compressor/limiter, which was developed for p.a. applications, uses the voltage-controlled attenuator designed by D. Self, *Wireless World*, December 1975. Resistor R<sub>1</sub> sets the threshold voltage and the compression law. The output signal from the attenuator is made as large as possible by the inverting CA3130 before being applied to the rectifier and low-pass filter. This minimizes the effects of diode non-linearities and capacitor leakage. The low-pass filter is necessary to obtain a fast attack time of around 500µs and long decay time of about 1 min.

The circuit was used successfully with a microphone in a p.a. system with no noticeable distortion. Bandwidth of the circuit is 15Hz to 25kHz.

M. B. Taylor,  
Kingston-upon-Hull.

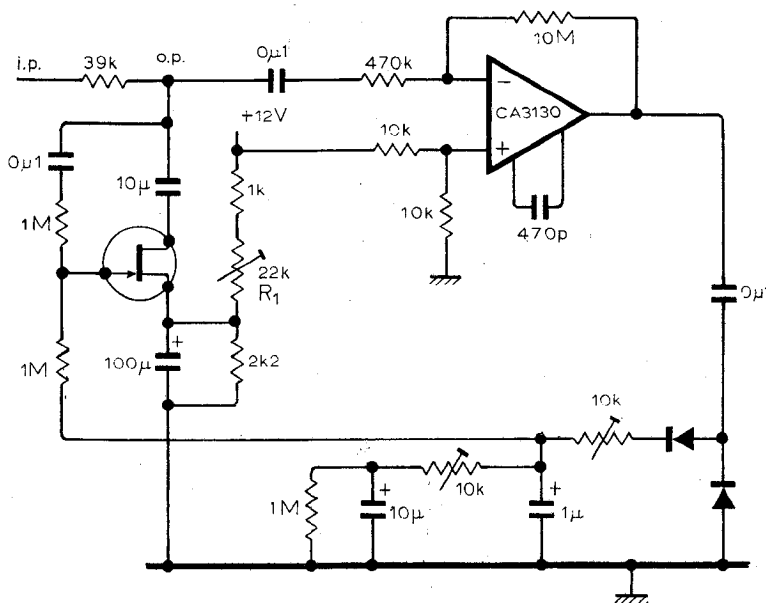



## Pulse-counting frequency comparator

With two periodic signals of nearly equal frequency, it is easy to generate their beat frequency and make it drive a pulse-counting discriminator. This produces an output voltage linearly proportional to the modulus of the difference frequency. The circuit shown works on the same principle but the output is positive or negative according to which input is at the higher frequency.

The Schmitt triggers and dividers convert the inputs to square waves of unity mark-space ratio. These i.c.s may be omitted if the inputs are already suitable, in which case divider (a) must be replaced by an inverting gate. Unity mark-space ratios are desirable if operation over the maximum range of beat frequency is required.

Dividers (c) and (d) produce two square waves in quadrature at frequency  $f_1/4$ . The interconnection of (c) and (d) ensures that the quadrature wave is always lagging. These waveforms together with  $f_2/4$  drive two D-type flip-flops as shown. The outputs at points X and Y define four possible states. Monostables (s) and (t) feed positive and negative-going pulses respectively, of constant area into a summing and integrating network to produce the desired output.

The output is proportional to the frequency if  $f_2$  lies between  $4/5 f_1$  and  $4/3 f_1$ . There is negligible offset on the output voltage because when the inputs are phase locked, neither monostable is triggering. The circuit can be used in frequency servo-systems where a signal has to be locked in frequency, though not in phase, to a reference frequency.

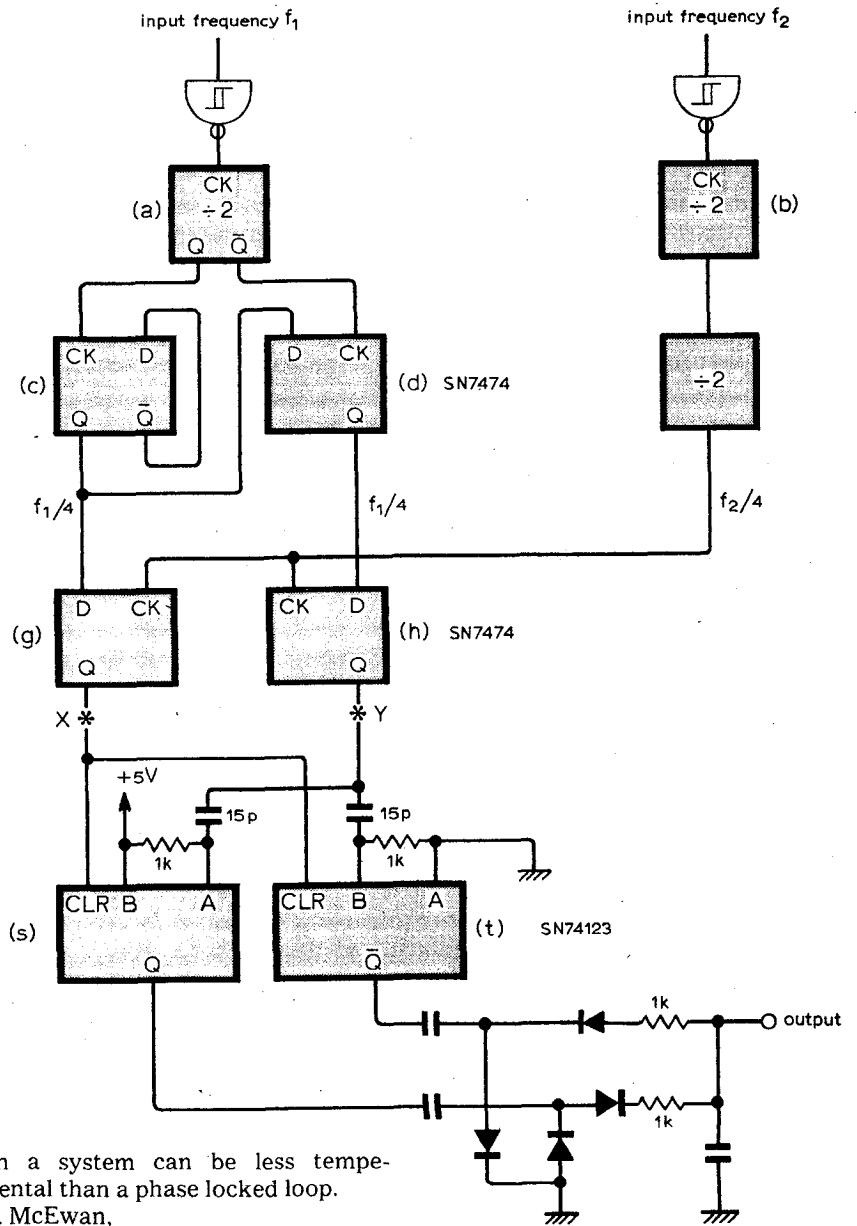

Such a system can be less temperamental than a phase locked loop.  
N. J. McEwan,  
University of Bradford.

## B.c.d. converter

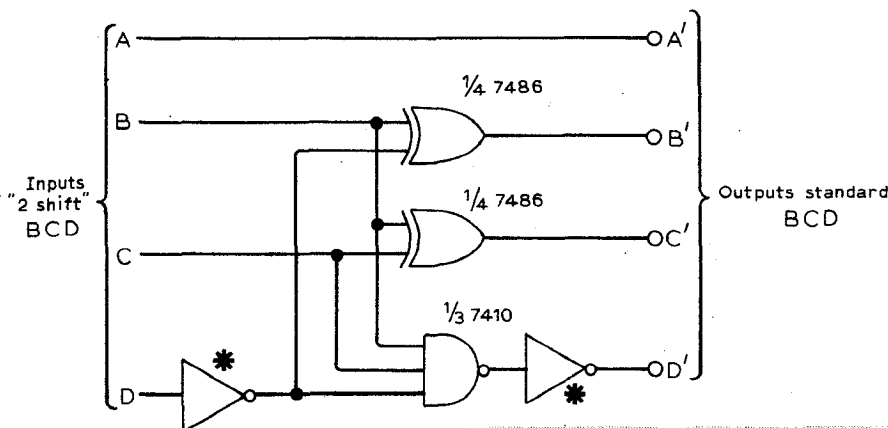

Conversion of "2 shift" b.c.d. to standard b.c.d. can be achieved with the circuit shown. Circuits which drive "Nixie" tubes or similar decimal displays may be economically converted for driving other displays such as seven segment i.e.d. types via a decoder driver i.c.

P. M. Weston,  
Birkenhead, Merseyside.

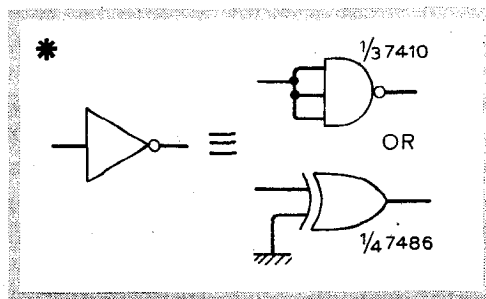

## Unusual sinewave generator

With the values shown the frequency is about 3.8kHz.  
Jorge S. Lucas,  
Brazil.

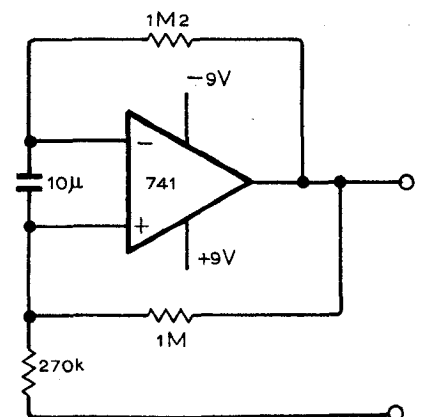

# A new tomography machine

Machines still appearing despite slowdown in the medical equipment scramble.

by John Dwyer

A company with less than 100 employees has launched what they say is "a diagnostic instrument complementary to the much publicised EMI scanner, but costing only a quarter of the price." Mr Anthony Bernard, managing director of J&P Engineering (Reading) Ltd, said in a statement: "We will be competing for sales with the EMI scanner, but in an ideal world the two pieces of equipment would be used together to provide an entirely new dimension to diagnosis." The price is £65,000.

The Tomoscanner uses a different technique from that exploited by EMI. Instead of measuring the degree to which certain tissues absorb external X-rays, the Tomoscanner measures the concentrations of injected chemicals within the body. This is known as an "invasive" technique. In a process called 'labelling,' radioisotopes are bonded to the molecules of the pharmaceutical used and radioactivity in a series of points in the organ under study is measured. Gamma ray photography has been used since the early '60s, but the resolution of the plots achieved with it has been notably less than seems possible with the Tomoscanner method, and it is only the use of a computer that enables the construction of a section through the patient. The radioactive dose the patient has to take is "comparable with a normal chest X-ray," according to technical director John Eppstein.

## Dual detectors

The patient lies on a padded plywood couch between two sensors placed at either side of the couch so that they can either rotate through a circle with the patient at the centre, or, for rectilinear scans used to build up a conventional profile, move in two parallel planes with the patient between them. The whole apparatus can be moved down the couch to take scans of any part of the body, though most of the clinical experience with the Tomoscanner, some 1,000 case histories over the last 18 months according to J & P, has been gained with brain scanning.

The detectors are sodium iodide, and the field of view is 40cm by 40cm. Using



*J & P Engineering's Tomoscanner. The two detectors are shown tilted at about 45°. They are each capable of detecting two different activity-level isotopes. The movements of the detectors, either around the patient, along her body or in two parallel planes at either side, can be controlled by a small hand-held device connected to the scanner.*

the moving couch for bone scans the field of view can be extended to 40cm x 160cm. The scanning speed is adjustable from 0 to 5cm with line spacings of 1.7, 2.5 or 3.4mm. Each detector can differentiate between two types of isotope, so that in the case of organs such as the liver and spleen, which may need to be viewed together but which absorb different pharmaceuticals, addition and subtraction can be used to differentiate between the two and to view them together.

In normal use, a rectilinear scan is first taken of, say, the upper half of the head. Each detector will provide a profile of one side of the head, or a view of the front or back. Once any abnormal features are seen on any of these scans, the Tomoscanner can take 30 angled views around the head in any plane through it. The information from each

of these scans is processed by a computer which assembles a printout showing a section about 12mm thick through the head in that plane. "The section image is computed as an 80 x 80 cell matrix, and is subsequently interpolated and played back as a 160 x 160 cell picture for display purposes." The printout is the same size as the patient's head. J & P say a typical scan lasts seven minutes, with another three for computing and plotting time. The printout can be in a scale of nine colours or a corresponding gray scale on X-ray plates.

J & P say the advantage of the method is that it shows only the organs under investigation, unlike the X-ray method, which shows up a lot of extraneous detail. "Experience . . . shows that the section view confirms lesions which are equivocal in other scans, and helps to distinguish between cerebral infarcts, subdural and extradural haematoma."

## Rivalry

J&P stress they have no wish to suggest that their machine in any way supercedes the X ray scanner, but EMI have taken exception to the ambiguity of a phrase in the J&P press statement saying: "the complementary isotope mission technique can yield more valuable clinical data of the physiological and biochemical processes for the same view." Neither do they see how it can give more physiological data than the X ray method. Linked with that, EMI say they see little point in trumpeting the selective nature of the Tomoscanner. If EMI want to show a particular organ, they say, they just use the appropriate part of the X ray scan, which can be altered in size to concentrate on chosen areas.

At a somewhat higher level of argument, one source involved in similar research described the Tomoscanner as "a backward step." Asked why, he said that it went against the general tendency to lower the radioactive doses administered to patients, with the eventual aim of using totally non-invasive techniques which can carry out all the clinical procedures needed without any danger or discomfort to the patient

at all, however slight. If isotopes of very low radiation were used absorption and scattering in the tissues between radiating organ and detector caused loss of resolution.

### Scan times

In the case of the Tomoscanner there is also the problem of long scan times. American machines, admittedly a very great deal more costly than either that or the EMI machine, can scan the patient in under 5s, well within the time that most patients can hold their breath. But in seven minutes, the Tomoscanner scan time, the body will make involuntary movements which produce a blurred image. That is one reason why early machines, such as the original EMI machine of early 1972, could only scan the head, which can be held still. The current EMI machine can scan in 20s, a considerable reduction on the original 4½ minutes.

Shorter scan times can be obtained by greatly increasing the number of detectors and, if an X-ray technique is being used, rotating the source to scan the detectors through the patient. This adds considerably to the cost, however, since the detectors may be the most expensive part of the device. A General Electric machine developed in the US used 320 Xenon detectors and cost \$615,000. The EMI system uses 30 detectors where once there were two.

Another difficulty of whole body scanning is that the range of tissue densities to be handled is so much greater. Yet typically the spread of densities is still very small. Whole blood has a specific gravity of 1.034, fat of 0.93, the liver 1.05, heart muscle 1.04 and breast tissue 0.97.

*Wireless World* asked Dr David Everett of the Medical Research Council's National Institute for Medical Research what he thought of the merits

of the two methods: "The present objectives in diagnostic medicine are towards the investigation of body functions. This is the strongest potential advantage of a radioisotope system over X-rays or ultrasonics, which can only reproduce the structure in the region of interest. The function of organs can be investigated by labelling gases for lung function, iodine for thyroid investigation etc. These are slow processes which can be partially followed with conventional gamma cameras and to some extent by X-ray and ultrasonic techniques, but the study of blood flow in the heart, for instance, poses a problem which we feel could be handled by our 'Compton' camera system. The medical implications of such imaging techniques are immense."

### Compton effect

The X-ray scanners currently in use have beam energies of around 70 keV and, like the gamma ray cameras,

operate mostly in the photoelectric region, the detector measuring simply the number of photons arriving at it normal to the detector.

At higher energies, between about 400keV and 2MeV for sodium iodide, the Compton effect takes over. In 1927 American physicist Arthur Compton was awarded the Nobel Prize for discovering that the trajectory of a photon incident on the electron of an atom in a low atomic weight absorber, in this case body tissue, can be calculated from the change in wavelength of the incident and scattered photons and their change in angle. Because the collision reduces the energy of the incident photon, there is a slight reduction in frequency, the scattered radiation containing both the original and modified wavelengths. This means there is a linear relationship between tissue density and the alterations in energy and direction of the X-ray photon.

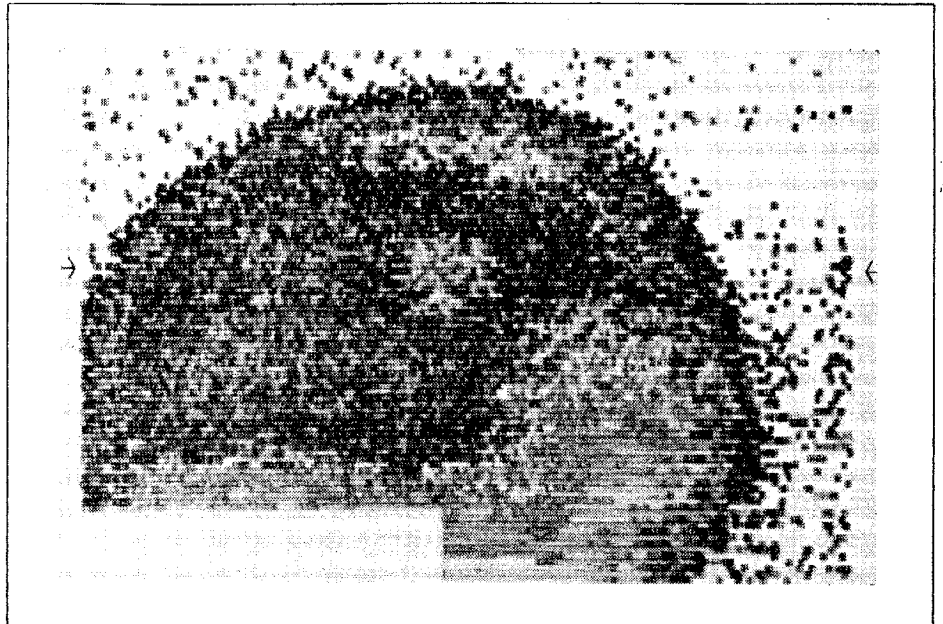

A scan of the left side of a patient's head. The lighter areas show high isotope activity, meaning that there has been increased blood flow to these regions where there should be none.

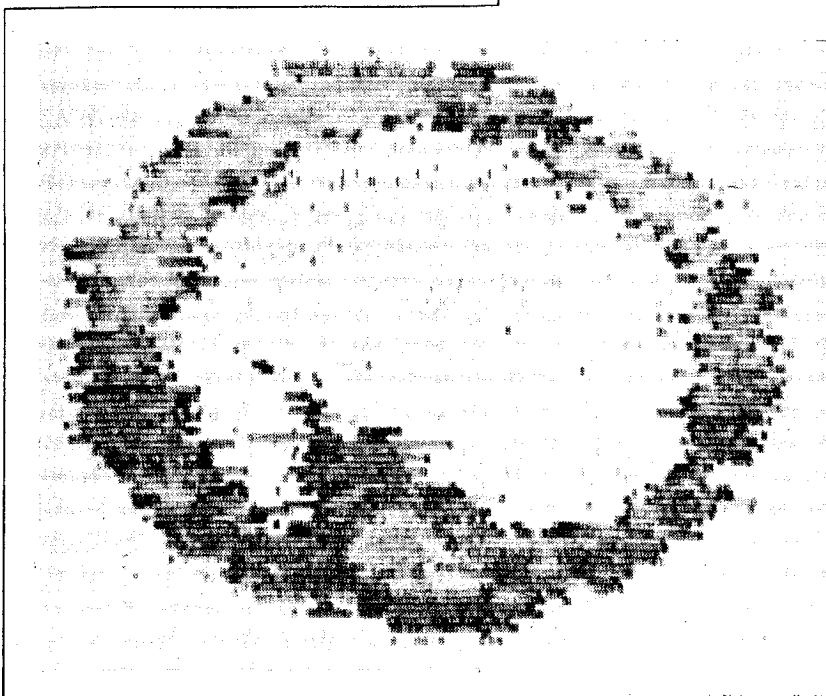

Having obtained the side view, the Tomoscanner is adjusted to take a section through the patient's head at the level of the light spot on the side view. This shows the result, which tells doctors the extent and shape of the abnormality. "Further investigation indicated presence of a parietal cyst associated with a mural tumour," say J & P. The large light area to the right of the left side scan proved to be a scalp lesion due to a plexiforma neuroma.

The detectors in present scanners are highly collimated to reduce scatter photons. EMI estimate that only about a thousandth of the particles reaching the detectors are used in building up the final picture. The Compton camera, which should be able to produce three-dimensional pictures, is an attempt to use all the particles, including the scatter, and, by measuring their incident angles, build up a picture of their trajectories before they reached the detector. This means using two arrays and observing the displacement the particle undergoes in travelling from one array to the next.

### Schottky arrays

In the Compton camera the detector is analogous to the lens in an optical system, and each photon incident on the detector defines an ellipse on the image plane. The source could be on any point on the circumference of that ellipse. Successive interactions produce a series of ellipses which intersect on the image plane to define a point. This point can be found by direct summation of all the ellipses generated. "It is possible to project images on to a multitude of planes using the same set of measurements, and even to superimpose them to obtain three dimensional images."

The Compton camera detector is based on a lattice of Schottky barrier orthogonal arrays of 0.4mm cubic elements. The elements are Schottky barrier junctions on n-type high resistivity silicon slices. There are 50 slices of silicon each 5cm in diameter and each having an associated energy amplifier, or photomultiplier. The imaging time is about a second. Resolution is about 2.5mm, compared with 8mm on conventional gamma cameras.

This technique is certainly attractive, particularly because of the number of photons being used, each one providing information and contributing to the final picture. But it has drawbacks. EMI say they have already thought about the technique a great deal. The chief scientist at EMI's central research Laboratories, Dr R. J. Froggatt, told *Wireless World* EMI had "done the sums and we are very, very dubious."

He identified two main difficulties: the particles may already have been through two or more collisions before they reach the Compton detector lens so "you're never sure where they're coming from"; and each time you looked at the incident photon, which you had to do twice, you tended to deflect it - it could not be incident on each of the two matrices without something happening to it. Dr Froggatt added, however, that "We're waiting to see whether they can bring it off."

### Scanner business fall

The US congress reported last August that there were about 300 scanners in use in the country and several hundred more on order. A year ago EMI's

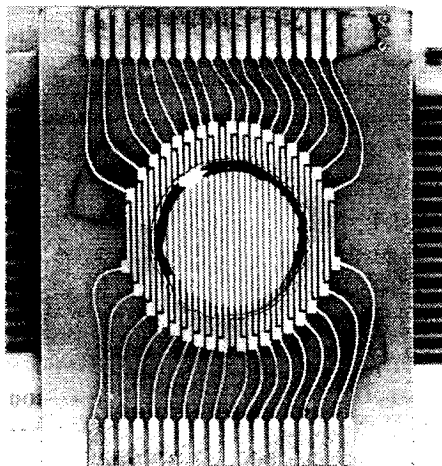

*One of the prototype silicon detector elements in the NRDC-funded National Institute for Medical Research Compton camera. Fifty such elements determine the trajectory of a gamma ray from a labelled pharmaceutical by measuring wavelength and path changes in photons. Southampton University teaching hospital and the National Centre for Alternative Technology were also involved.*

excellent financial record for the year to the end of the previous June was largely attributable to the success of their brain scanner, even before the body scanner had gone into production.

EMI's brain scanner was the first. In October 1973 the American National Biomedical Research Foundation announced a colour, whole body scanner with better resolution, they claimed, than that from a normal X-ray. EMI's body scanner arrived in July 1975, and by September press reports in American journals were reflecting the growing size of the scanner bandwagon.

Digital Information Sciences Corporation began to make the scanner developed by NBRF, and it was marketed in the US by Pfizer medical systems. Ohio-Nuclear made another scanner which Siemens marketed in Europe as well as their own Siretom scanner. Ohio-Nuclear told the American journal *Electronics* in September 1975 that they expected to sell \$50 million worth to Siemens alone. The world wide market at this time was estimated at around 10,000 units a year, with an average price of perhaps \$0.5 million each. General Electric jumped in with their 5s scanner and, in a single week in December that year, half a dozen new makers of scanning equipment announced their products.

### Medical instrument legislation

There has been growing concern in America about the proliferation of scanners, and it has been suggested that patients are not benefiting as greatly from that proliferation as they might. The same congressional report said that each machine scanned 12 patients a day

at a charge of at least \$200 per scan. So Americans now appear to be spending at least \$200 million a year on scanning although, the report says, many more scans are being made than can be accounted for by substitution for previously available techniques. The implication is clear: that some patients are paying for scans they don't need.

Linked with this is the enactment of the 1976 Medical Device Amendments to the Food, Drug and Cosmetic Act. The amendments followed agitation by the Association for the Advancement of Medical Instrumentation as far back as 1969, and the setting up by the department of Health, Education and Welfare of a study group under the chairmanship of the director of the National Heart and Lung Institute, National Institutes of Health, Theodore Cooper. The Cooper report advocating legislation to improve safety was published in September 1970, and various bills were introduced in congress over the following years, as well as bills sponsored by the administration, but because of delays caused by Watergate, among other things, it was not until May last year that the legislation was signed, by President Ford.

### Devices "too exotic"

The Amendments will oblige manufacturers to establish the safety and effectiveness of their products to the satisfaction of the food and drugs administration before they are marketed. The journal *IEEE Spectrum* reported in January that "compliance with this new law may result in increases in the costs of medical devices. And ... real questions have arisen as to the cost benefit and cost effectiveness of such expensive equipment."

Throughout the seventies doctors have been criticising the standards of medical instruments. In 1973 the *Electronics* interviewed 12 doctors, most of whom said that "the electronics industry has a tendency to place too much emphasis on exotic devices with little or no legitimate applicability, while insufficient stress is placed on a variety of urgent problems, some of which appear to be mundane." There was concern that in the welter of instrumentation the patient might be forgotten.

Dr Froggatt of EMI says he thinks it would be difficult to prove that there was any racketeering in X-ray scanning, but he felt the British public were well protected in any case because there were very many fewer patients paying for their own treatment. In addition, he thought that scanning had provided a useful amount of clinical information.

Whatever doubts may be being expressed elsewhere, J & P are gearing up for a boom. Managing director Anthony Bernard said in a statement: "If the Tomoscanner generates the global attention we expect, then a large and rapid expansion is in prospect."

# New Products

## Terminal covers

A range of insulating terminal covers, from Highvol Connectors Ltd, have been developed to comply with international safety regulations. The covers are preformed and require no heating or chemical agent for attachment to their terminals. The range includes many different covers to suit wire and cable terminals of most shapes and sizes. Highvol Connectors Limited, Uddens Trading Estate, Wimborne, Dorset BH21 7NL.

WW301

## Digital multimeter

In addition to a 3½-digit, 11mm l.e.d. display, the 460-3 multimeter has a calibrated analogue meter, intended for nulling and scanning peaks and variations. The meter has 32 overload-protected, push-button ranges giving five direct voltage ranges up to 1000V, five alternating voltage ranges up to 600V, six a.c. and six d.c. ranges, both up to 10A, and five resistance ranges up to 2MΩ. There are also five low-power

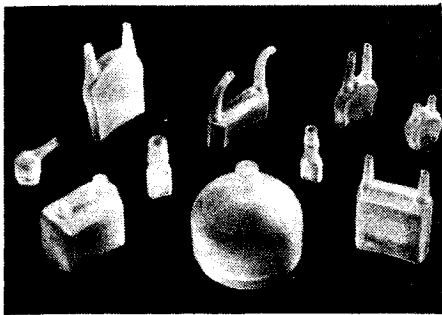

WW301

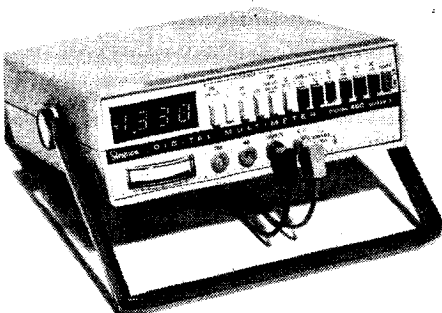

WW 302

resistance ranges up to 2MΩ. Accuracy on all direct voltage ranges is ±0.1% of reading plus one digit. The instrument, available in either mains/rechargeable battery or mains only, is priced at about £200. Bach-Simpson (UK) Limited, Trenton Industrial Estate, Wadebridge, Cornwall PL27 6HD.

WW302

## Crystal frequency sources

Small plastic encapsulated crystals, in the SPXO range from Cathodeon Crystals Ltd, provide a stability of ±0.002% over the range 4 to 10MHz, operating in the temperature range -20 to +70°C. Pin positions are on a standard 0.1in grid but a variety of mounting arrangements are also available. Cathodeon Crystals Limited, Linton, Cambridge CB1 6JU.

WW303

## Inductance bridge

The model B324, from Wayne Kerr, is a low-inductance bridge suitable for measuring audio-frequency coils, as used in amplifiers, filters and telecommunication circuits. The unit provides a choice of three switch-selected measurement frequencies, 400Hz, 1kHz and 10kHz, and an adjustable test signal level. An aperiodic high-gain amplifier is used as the detector and provision is made for the connection of an external tuned detector for specialized tests. On its most sensitive range, the discrimination available from the B324 is 1nH and 100μΩ. Top values measurable are 1.111H and 11.11kΩ. The bridge is subject to a maximum error of 0.25% up to 10mH and 1kΩ, increasing to 0.5% for measurements of higher values. Wilmot

Breeden Electronics Limited, 442 Bath Road, Slough SL1 6BB.

WW304

## Power supplies

A series of chassis-mounting power supplies, from Dattel Systems, comprises two single-output models, types UCM5/1000 and UCM5/2000, and three dual-output models, types BCM15/100, BCM15/200 and BCM15/300. The UCM models are designed for digital applications and have outputs of +5V d.c. at 1 and 2A respectively, with line regulations of 0.05% max, load regulations of 0.1% max. and output ripples of 1mV r.m.s. max. The BCM models are designed for linear applications and these have outputs of ±15V at 100, 200 and 300mA respectively, with line regulations of 0.02% max., load regulations of 0.05% max. and output ripples of 2mV r.m.s. max. Units are encapsulated in a phenolic case measuring 3.5in long by 2.5in wide and up to 1.56in high. Dattel Systems Incorporated, 1020 Turnpike Street, Canton, Mass. 02021 U.S.A.

WW305

## Mains capacitors

A range of paper and foil Duralit capacitors, from Wima, is approved to VDE0560-7 for use between line and neutral (Class X), for 630V ratings, and for use between line and earth (Class Y), for 1000V ratings. The capacitors, which are available in values from 470 to 4700pF, have axial leads and are epoxy resin impregnated for a high ionization inception level. These capacitors can also be supplied for 400 and 1250V. Waycom Limited, Wokingham Road, Bracknell, Berks.

WW306



WW304



## Television aerials

Three television aerials, having extra large screen grid reflectors, have been added to the range available from Jaybeam Ltd. Type MSG-8 has eight-by-four directors, type MSG-15 has 15-by-four directors and type MSG-21 has 21-by-four directors. In addition to the above, each aerial has two launch directors. These aerials, which are available for television channel groups A (21 to 24), B (39 to 53) and C (48 to 68), give improved directivity and signal rejection characteristics compared to previous models. Maximum gain figures, referred to a half-wave dipole and measured in accordance with IEE 138A/63 and BASC recommendations, are 14, 16 and 18dB respectively. Jaybeam Limited, Moulton Park Industrial Estate, Northampton NN3 WW307

## Ceramic interference filters

Filters in the 1000 and 2000 series are 100% tested and are suitable for use up to 240V and 400Hz. Type 2000 has a relatively stable dielectric and is for use in military and aerospace applications requiring high reliability and a capacitance change of less than  $\pm 20\%$  over the range  $-55$  to  $+125^\circ\text{C}$ , together with a guaranteed insertion loss over this range. Type 1000 uses a slightly less stable and cheaper dielectric and is suitable for commercial and industrial applications. These filters meet the requirements of MIL-SPEC-202 and MIL-F-15733. Uncased ceramic disc filters, giving up to 10 times as much capacitance per unit volume, are also available. G. E. Electronics (London) Limited, Eardley House, 182/4 Campden Hill Road, Kensington London W8 7AS. WW308

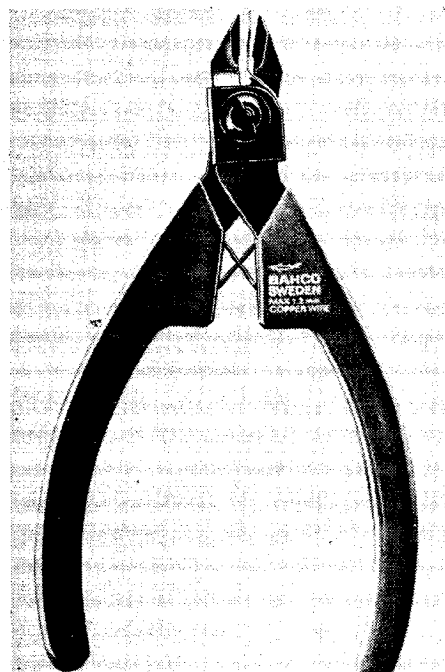

WW 310

## Low profile keyboards

The KL series of low profile keyboards are now available with encoding facilities for dual tone multi-frequency switching, for communications applications, and row and column formats for microprocessor systems. These keyboards, called Minikeys, have precious metal contacts with ratings of 50mA at 28V d.c. resistive. The top of each key on the Minikey extends only 1.78mm from the face of the keyboard and has a travel of 1.27mm. Total keyboard depth is less than 3.12mm. Tactile "feedback" is by a mechanism which ensures fast positive closure of the contact. Prices for a one-off are from £5.20. Digitran Endevco UK Division, Melbourn, Royston, Herts SG8 6AQ. WW309

## Wire cutters

Two low-cost side cutters, types 2131 and 2132 from Bahco Tools Ltd of Sweden, are produced by blanking instead of forging, depending on grinding and heat treatment for the cutting edges. Bahco claim that the useful life of the cutters, which cut copper wire from 0.3 to 1.2mm dia., is comparable to that of more expensive forged patterns. Type 2131 has a bevel on the outer face of the jaws, while type 2132 has no bevel and may be used for flush cutting. The pliers have polypropylene grips for comfort, and include a detachable clip which holds the wire off-cut after each operation. Prices are £6.38 each. Bahco Tools Ltd, Bahco House, Beaumont Road, Banbury, Oxon. WW310

## Low-loss soft ferrites

Ceramag 24B is a ceramic ferrite material which, it is claimed, offers a reduction in losses of 30% at

16kHz and 25% at 60kHz, with no changes in permeability or saturation. In addition, losses are lowest in the range 85 to 95°C. A wide range of these cores is available, including E-cores with heights of 0.937in and lengths up to 4.062in, and toroids up to 5.938in outside diameter. Walmore Electronics Limited, 11-15 Betterton Street, Drury Lane, London WC2H 9BS. WW311

## 10MHz oscilloscope

The VP-5100A is a general-purpose 10MHz oscilloscope having nine calibrated ranges from 10mV/div. to 5V/div. A variable control allows continuous variation between steps up to 12.5V/div. In addition to seven calibrated sweep rates, from 0.1 $\mu\text{s}$ /div. to 0.1s/div., the timebase provides a mode for viewing composite TV signals. Telonic Altair UK, 2 Castle Hill Terrace, Maidenhead, Berkshire SL6 4JR. WW312

## Strain gauge indicator

The Doric 420 Digital Indicator displays the output of strain gauge devices in engineering units. This instrument can be used to measure pressure, torque, thrust and force, etc., with a resolution of one part in 10,000. The sensitivity is adjustable from 1 to 12 $\mu\text{V}$  per increment. Five 0.63in l.e.d.s provide the display. Lee Engineering, Napier House, Bridge Street, Walton-on-Thames, Surrey KT12 1AP. WW313

## Miniature slide switch

A single-pole, double-throw slide switch, type 1101, is said to be capable of breaking 6A at an alternating voltage of 120V or a direct voltage of 28V. The

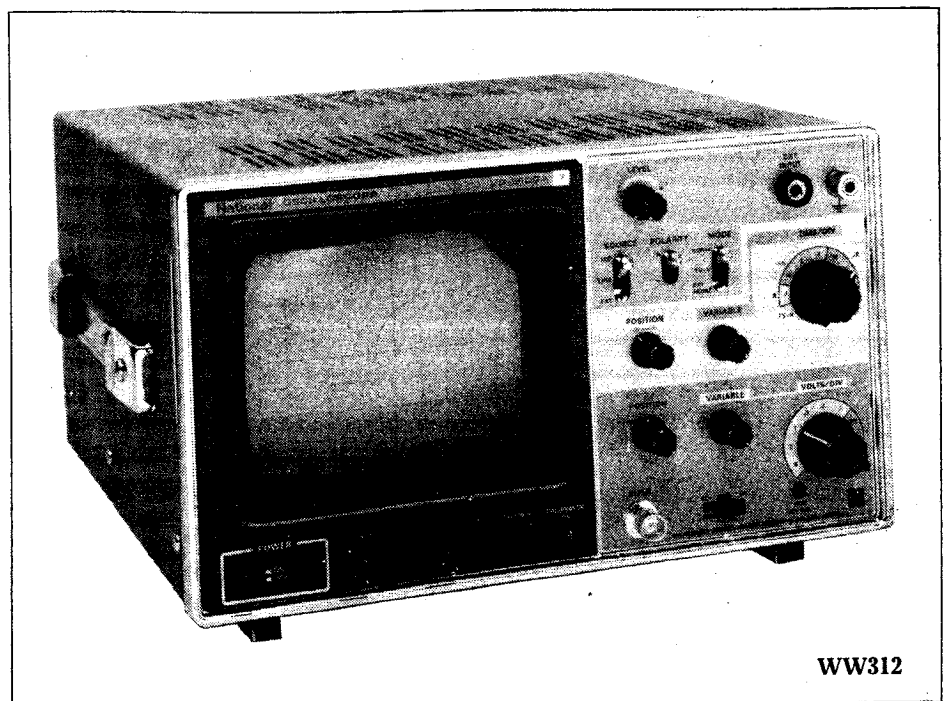

WW312

switch, which incorporates the C & K toggle mechanism, measures  $0.5 \times 0.26 \times 0.25$ in and may be mounted directly on to a p.c.b. Typical characteristics include a maximum contact resistance of  $10\text{m}\Omega$ , minimum insulation resistance of  $100\text{G}\Omega$  and dielectric strength of  $1\text{kV r.m.s.}$  Roxburgh Electronics Limited, 22 Winchelsea Road, Rye, Sussex.

**WW314**

### Microwave absorber

A flexible microwave absorber called Eccosorb RMP is intended for frequencies of 2.4GHz and above. The absorber, available in silicone rubber (RMP-S-75) or vinyl rubber (RMP-V-75), is a mould of pyramids each having a height of about 2.5cm and a base of about 2.54cm square. The silicon product is fabric reinforced and is preferred for high temperature, high power and airborne applications. The vinyl absorber is more rugged and is intended for outdoor use. Both products have nominal reflectivities of 17 to 20dB down, over the useful frequency range, and are supplied in 30.5cm square sheets. Both absorbers conform to curvature, can be bonded in place and cut with a knife. Neither product will support combustion. Emerson & Cuming (UK) Limited, Colville Road, Acton, London W3.

**WW315**

### Programmable pulse generator

A programmable pulse generator, designated as model EH1501A/129, is specifically designed for e.c.l. and other high speed applications. The programmable output stage can deliver positive or negative pulses of up to 2V amplitude and  $\pm 1\text{V}$  offset with rise and fall times of less than 500ps at full amplitude. This generator has a programmable fre-

quency of up to 50MHz. A variety of programming interfaces are also available and include the IEC 488 and facilities such as memory read-out or optical isolation. Elex-Electronics, 22-24 Bell Street, Henley, -on-Thames, Oxfordshire RG9 2BG.

**WW316**

### Piezo-electric sounder

A long-life, low-power piezo-electric sounder, the U3-50R, generates a single tone in excess of 85dB at a rated current of 8mA and rated voltage of 24V. The sounder, which is 60mm square and 10mm deep, has no moving parts and is claimed to have a life of 1000h, compared with about 50h for a conventional electro-mechanical bell. ITT Components Group Europe, Standard Telephones and Cables Limited, Edinburgh Way, Harlow, Essex.

**WW317**

### Spectrum analyser

A spectrum analyser, from Court Acoustics, uses a 28 by 11 i.e.d. matrix, measuring  $14 \times 4$ in, to provide an easy-to-read real-time display of audio frequencies from 28Hz to 20kHz with standard ISO centre frequencies from 31.5Kz to 16kHz. An extra i.e.d. display reads the full programme level, in dBm on line settings and in s.p.l. on microphone settings. Facilities are included for a 2.5ms attack and decay, a 2s decay, peak accumulation readings and display storage. The unit has a digital pseudo-random noise generator with a word length of 16Mbits which can provide pink or white noise to an isolated socket. On pink noise an output of 20Hz to 20kHz  $\pm 0.5\text{dB}$  is available with a peak-to-mean ratio of 4:1. Court Acoustics, 50 Dennington Park Road, West Hampstead, London N.W.6.

**WW318**

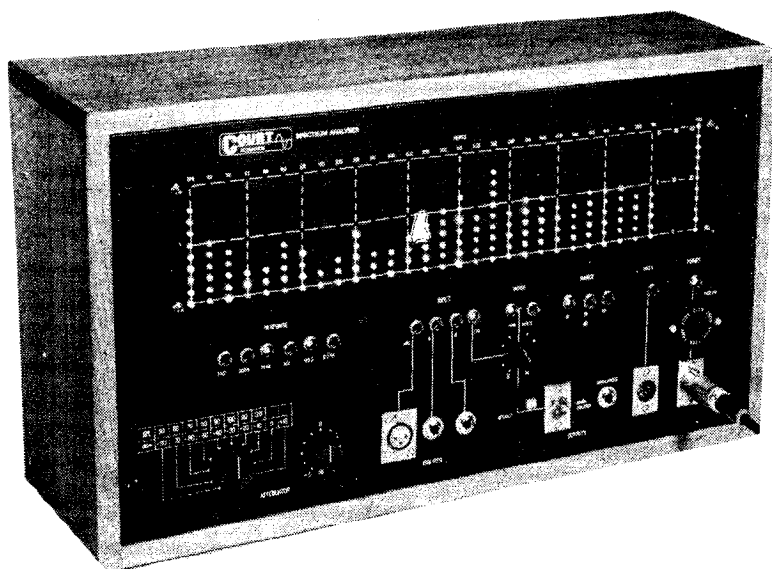

**WW318**

### Low-cost logic wiring system

The Wire Distribution System, from Zartronix, uses solderable synthetic enamel wire (36 s.w.g.) for producing prototype logic circuit boards. The point-to-point wiring is retained by moulded distribution strips which may be used for any desired i.c. packing density. Two types of strip are available: a general purpose moulding which can be used on all types of circuit board (when used with a quick-set adhesive), and another, designed specifically to press fit into any board with 1mm dia. holes on a 2.54mm pitch matrix. The versatility of the strips ensures that there is no restriction on size or type of prototype breadboard used. An introductory kit is available and consists of wire distribution strips and pencil, a spare spool, i.c. leg deformer, circuit board and a comprehensive instruction leaflet. Zartronix, 115 Lion Lane, Haslemere, Surrey.

**WW319**

### Wire-wrapping tool

A battery-operated wire-wrapping tool from Vero Systems Ltd, is designed for 0.63mm square terminals using 0.25mm wire. The tool, priced at £32.50, is fitted with a bit and sleeve so that  $1\frac{1}{2}$  turns of insulation are wound around the terminal before the bare-wire wrap is made. A built-in device prevents overwrapping and the unit is self-indexing to simplify use and provide a constant wire turn consistency. The tools are moulded from impact resistant material, weigh 11 oz and can be supplied with rechargeable nickel-cadmium batteries and a charger. Vero Systems (Electronic) Limited, 362a Spring Road, Sholing, Southampton.

**WW320**

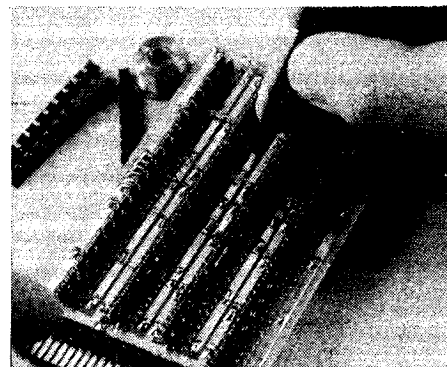

**WW319**

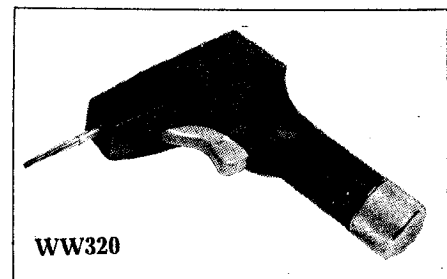

**WW320**

## Breakdown voltage tester

An instrument, available from Stoneleigh Electronics Ltd, has been designed for determining the voltage breakdown characteristics of transistors, diodes, neon lamps and other semiconductor devices. The device to be tested is placed across the test terminals of the instrument and then a constant current source, which can be set within the range of 1 to 15mA, is applied to it. This source has an output potential of up to 300V. The breakdown voltage is then displayed on a voltmeter which has switched ranges of 10, 30, 100 and 300V f.s.d. The instrument, which can also be used to check voltage ratings of semiconductor devices, has a polarity switch allowing forward and reverse characteristics to be checked quickly. Stoneleigh Electronics Limited, Mawney Road, Romford, Essex RM7 7SE.

WW321

## Infrared pyroelectric vidicon

The P8092 is a 1in vidicon which is sensitive to infrared radiation from 1.8 to 1000 $\mu$ m, with optimized performance in the 8 to 14 $\mu$ m band. When used with a high-performance lens, this tube can resolve increments in scene temperature of less than 0.2°C. The tube has a spatial resolution capability of 300 TV lines, and deuterated triglycine-sulphate target having a useful diameter of 18mm. The P8092 requires no gas coolant or mechanical scanning system and it has a fully compatible TV output signal. English Electric Valve Co. Limited, Chelmsford, Essex CM1 2QU.

WW322

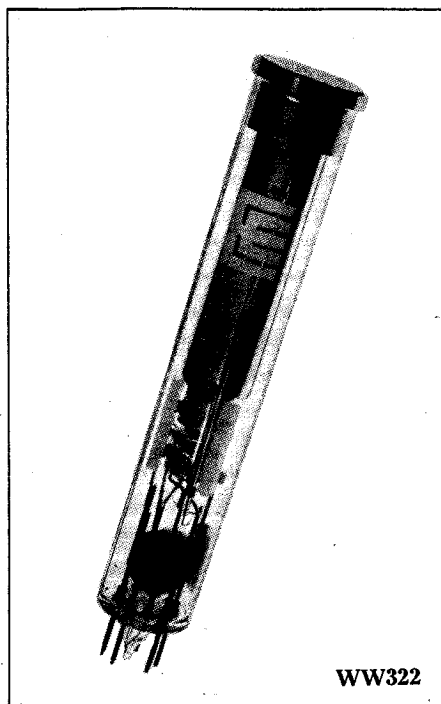

WW322

# Solid State Devices

## High-power switching transistors

Four transistors, designated as RCA-2N6338, 2N6339, 2N6340 and 2N6341, have maximum rise and fall times of 0.3 and 0.25 $\mu$ s respectively at a collector current of 10A d.c. Voltage ratings are high, for example  $V_{CB}$  (max) for the 2N6341 is 180V. For an  $I_C$  of 10A,  $V_{BE}$  (sat) is only 1.8V and with an  $I_C$  of 25A a high gain is maintained and a minimum forward-current transfer of 12 is obtained. The devices are in hermetic steel TO-3 packages. RCA Solid State-Europe, Sunbury-on-Thames, Middlesex TW16 7HW.

WW323

## Fast-recovery rectifiers

A range of fast switching rectifiers, designated as the RGP series, has devices rated at 1, 1.5, 2 and 3A with peak-inverse voltages between 50 and 1000V. The rectifiers, which are claimed to meet all international requirements, have recovery times varying from 150ns for 50V types to 500ns for 1000V types. Typical reverse leakage currents are less than 1 $\mu$ A. In all cases the peak forward surge currents are at least 30 times the rated value. The devices comply with UL flammability classification 94V-0 and generally exceed the environmental MIL-Std-19500/228. General Instruments UK Limited, Cock Lane, High Wycombe, Bucks.

WW324

## Field programmable logic array

Two military-range versions of industrial programmable logic arrays (f.p.l.a.s.) are now available from Mullard. Type S82S100 has a three-state output and type S82S101 is an open-collector version. The Schottky-t.t.l. devices employ nichrome fuse technology and have typical power dissipations of 600mW and maximum access times of 80ns. Signetics IC Marketing Group, Mullard Limited, Mullard House, Torrington Place, London WC1E 7HD.

WW325

## V.h.f. m.o.s.f.e.t.

The BF327 is a protected-gate depletion mode m.o.s.f.e.t. suitable for use in v.h.f. amplifier and mixer circuits. It has a low feedback capacitance of 0.03pF, a low noise figure, typically 2.3dB, and offers high gain. The plastic encapsulation reduces manufacturing costs without

impairing performance and conforms to the outline requirements popularly adopted as the European standard for these v.h.f. and u.h.f. devices. Mullard Limited, Mullard House, Torrington Place, London WC1E 7HD.

WW326

## R.f. transistor

The BFT96 transistor has been added to the range of silicon p-n-p devices available from SGS-ATES. This transistor is a driver or medium power amplifier giving linear outputs up to 0.5V across 75 $\Omega$  at 1GHz. By using the BFT96 with the BFT95 (see New Products August 1976) as the first stage in a wideband amplifier, typical noise figures of 2dB can be obtained between 40 and 1000MHz. The two devices may also be used for medium-power complementary applications for centralized antennae systems. SGS-ATES (UK) Limited, Walton Street, Aylesbury, Bucks.

WW327

## Planar transistor

The BFW92, from SGS-ATES, is an n-p-n silicon planar transistor designed for use in broadband amplifiers. It offers low noise (4dB at 500MHz) and low cross-modulation with a high  $f_T$  (1.6GHz). The package is in a common-emitter configuration and offers reduced parasitics for u.h.f. applications. SGS-ATES (UK) Limited, Walton Street, Aylesbury, Bucks HP21 7QN.

WW328

## Avalanche diodes

Two silicon planar epitaxial controlled-avalanche diodes, types BAW21A and BAW21B, are fast switching devices intended for use in general applications where transients occur, or where a very steep forward characteristic is required. Avalanche breakdown voltages are 90 to 150V for type A and 120 to 175V for type B, at an  $I_r$  of 100 $\mu$ A. The diodes, in a DO-35 package, have maximum rectified forward currents of 0.4mA when averaged over a 20ms period. Mullard Limited, Mullard House, Torrington Place, London WC1E 7HD.

WW329

## Impatt diodes

Two Read-profile Impatt diodes, types MS927A and MS927B, are intended for operation from 12 to 14GHz. The MS927A offers a power output of 2.5W minimum at 20% minimum efficiency and the MS927B is for 1.5W minimum at 15% minimum efficiency.

Walmore Electronics Limited, Microwave Division, 11-15 Betterton Street, Drury Lane, London WC2H 9BS.

WW330





## Small wonder.

One of the world's smallest dynamic-element lavalier microphones is designed to be heard, not seen. Other mini-mics may be O.K. at first, but, as you know, there have been problems with sudden failures... sometimes on the air! The new Shure SM11 lavalier solves the problem with an unusually high quality dynamic element that delivers all the reliability of a desk microphone—yet it weighs less than a third of an ounce.

Rugged, all-around durability and a

field-serviceable design keeps this new breed of lavalier on the air when you need it most. Without batteries or unnecessary wiring. And without a big price tag either.

The SM11 has everything: size, performance, durability, price. That's not just small talk!

Shure Electronics Limited  
Eccleston Road,  
Maidstone ME15 6AU  
Telephone: Maidstone (0622) 59881

### TECHNICORNER

Frequency Response: 50 to 15,000 Hz  
Polar Pattern: Omnidirectional  
Impedance: 150 ohms (200 ohms actual) for connection to microphone inputs rated at 25 to 200 ohms  
Hum Pickup: Less than 35.3 dB equivalent SPL in a 1 millioersted field  
Accessories Supplied: Specially designed lavalier assembly; clip-on clasp; tie-rack assembly; connector belt clip.





# “There’s a lot more to Multicore...”



Multicore Fluxes, Chemicals, Preservatives, Cleaners and Conformal Coatings. For highest quality soldering.



Multicore Oxide-free Solder Creams. For microcircuits and P.C.'s. Also a wide variety of pre-forms for repetitive soldering operations.

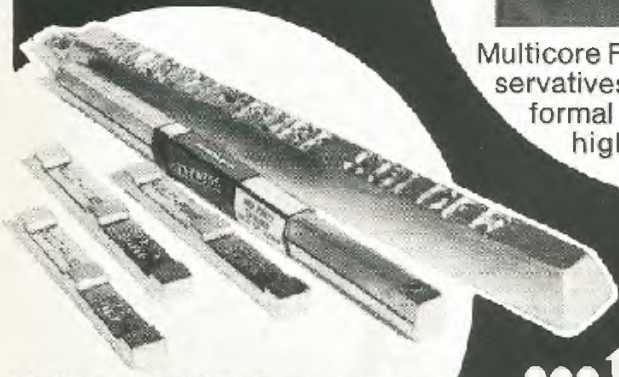

Multicore Solid Solders. In Bars, Ingots, Sticks, Wire or Pellets. For all dip and wave-soldering.

## ...than meets the iron!



Multicore Solderability Testers. MK III - Tests components semi-automatically. New PTH - tests plated-through-holes in P.C. boards automatically.



Multicore now solders the 'impossible'. ALU-SOL 45D solders most types of aluminium and has a good corrosion resistance. Arax 96S for difficult stainless steels, being non-toxic and bright.



### “The name that stands for quality and quantity.”

Please write on your Company's letterhead for further details on your particular application.

**Multicore Solders Limited,**

Maylands Avenue, Hemel Hempstead, Herts HP2 7EP. Tel: Hemel Hempstead 3636. Telex: 82363.