

# Wireless Weekly

Vol. 5. No. 22.

## *FORTY METRES AND BELOW*

By JOHN L. REINARTZ.  
(Inventor of the Reinartz Tuner.)



# Really reliable Rheostats—British-made by BURNDEPT

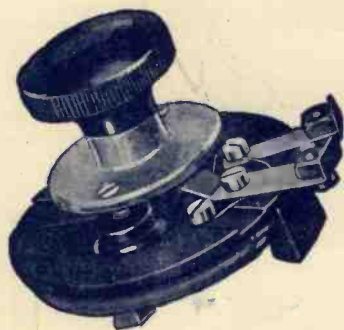

**No. 222.** Burndept Dual Rheostat, 5-30 ohms. Suitable for a DE<sub>3</sub> valve (4½ v.) or an R<sub>4</sub> or R<sub>5</sub> valve (6v.), 7s. 6d.

**No. 272.** 1.4 ohms, 3 amps. Suitable for 3 or 4 R<sub>4</sub> or R<sub>5</sub> valves and for single transmitting valves up to 40 watts, 6s. 6d.

**No. 271.** 3 ohms, 2 amps. Suitable for 2 DER (4v.), 1 R<sub>5</sub> (6v.), 2 R<sub>4</sub> or LS<sub>3</sub> (6v.), 1 LS<sub>2</sub> or LS<sub>5</sub> (6v.), 1 Weco (1½ v.), 2 Weco (2v.), or 2 DE<sub>5</sub> (6v.) 5s.

**No. 270.** Standard single-valve rheostat, 7 ohms, 1 amp. Suitable for 1 R<sub>4</sub> or LS<sub>3</sub> (6v.), 1 DER (4v.), 2 DER (6v.), 1 Weco (2v.), or 1 DE<sub>5</sub> (6v.) 5s.

**No. 313.** 15 ohms, 5 amp. Suitable for 1 DER (6v.), 2 Weco (4 or 6v.), or 2 DE<sub>3</sub> (4v.), 6s. 6d.

**No. 274.** 30 ohms, 25 amps. Suitable for 1 Weco (4 or 6v.), 1 or 2 DE<sub>3</sub> (4½ v.), 1 DE<sub>3</sub> (4v.) or 2 DE<sub>3</sub> (6v.), 7s.

**No. 273.** Potentiometer, 200 ohms, 1 amp. 7s. 6d.

*In the above list, the figures in brackets indicate the voltage of the accumulator or dry cells to be used*

**W**HEN a man buys a rheostat, he studies these points: the efficiency of the component, its appearance and the quality of the material used. On each point Burndept Rheostats give perfect satisfaction. They are reliable in operation, neat in appearance, and are noted for their smooth-running, noiseless, frictional contact.

The base of each Rheostat is moulded of special heat-resisting compound, placed so that the heat from the element cannot spoil the panel. Rheostats 270, 271, 272 and 313 have self-supporting wire-wound elements. All the remaining types are wound on a special flexible former, through the centre of which runs a spiral steel spring. Owing to this patented method of construction, the former yields slightly to the phosphor-bronze brush which moves with a "silky running" effect and makes perfect contact. The windings cannot be displaced. The top bush of each Rheostat is black-nickelled and the knob is made of the best quality polished ebonite. The Rheostats are easily fitted to any panel from ¼ to ¾ inches in thickness. In each carton will be found a drilling template, together with a twelve-month guarantee label.

The Burndept Dual Rheostat (No. 222) is a triumph of design and fills a real want. It enables you to use a bright or a dull-emitter valve without making alterations of any kind to your set. The first half of the element is wound to a resistance of 25 ohms, and the second, to a resistance of 5 ohms. The whole 30 ohms resistance is used to control a dull-emitter valve, and the 5 ohms resistance, a bright valve.

*Purchase Burndept by its name—substitutes are not the same.*



## Variable Condensers of great efficiency

However severely you test Burndept variable Condensers, you will find them far better than others. Their efficiency is remarkable, the losses being extremely low. The patented bearings ensure perfect contact and give a very smooth movement. Full particulars and prices will be sent on request.

# BURNDEPT

## WIRELESS APPARATUS

BURNDEPT LTD., Aldine House, Bedford Street, Strand, London W.C.2.

Telephone: Gerrard 9072. Telegrams: Burndept, Westrand, London.

LEEDS: 12, Basinghall Street (near City Square).

CARDIFF: 67, Queen Street. NORTHAMPTON: 10, The Drapery.

NEW BRANCH:

Winchester House, Victoria Square, BIRMINGHAM.



# Wireless Weekly

## Radio Press, Ltd.

BUSH HOUSE, STRAND, W.C.2.

Tel.—City 9911.

EDITED BY JOHN SCOTT-TAGGART, F.Inst.P.,  
A.M.I.E.E.

Assistant Editor:  
PERCY W. HARRIS,  
M.I.R.E.

Scientific Adviser:  
Prof. G. W. O. HOWE,  
D.Sc., M.I.E.E.

Advisory Editors:  
Prof. R. WHIDDINGTON,  
M.A., D.Sc.

Prof. C. L. FORTESCUE,  
M.A., M.I.E.E.

Staff Editors:  
E. H. CHAPMAN,  
M.A., D.Sc.  
A. D. COWPER,  
M.Sc.  
R. W. HALLOWS,  
M.A.  
G. P. KENDALL,  
B.Sc.  
STANLEY G. RATTEE,  
M.I.R.E.

Vol. 5, No. 22

MARCH 18, 1925

Price 6d. net.

## Programmes Good and Bad.

NOT long ago we commented in these columns on the appearance of a new type of broadcasting programme—that presented through the British Broadcasting Company's stations by an outside organisation, which is content to foot the bill for the direct or indirect advertising value such a programme can give. A start was made by a well known morning newspaper and the artists chosen were certainly well above the average presented by the B.B.C. in their own programmes. Just recently we have listened to a still better programme, including such internationally famous artists as Tetrizzini and Lamond, the entertainment on this occasion being provided by an enterprising London evening journal. There is no need to comment upon the excellence of this last programme, for it must have been heard by a large percentage of our readers, and the praise ungrudgingly awarded to it by the Press generally was certainly a noteworthy feature.

It will readily be admitted that in the past the British Broadcasting Company has been hampered by the attitude adopted by certain concert agencies who would not allow their artists to broadcast in any circumstances. Yet it is disturbing to find that a newspaper can manage to give a better programme than the Broadcasting Company itself has so far presented. It is not suggested for one moment that it is possible, even with the funds that the B.B.C. has at its disposal, to give nightly programmes of such excellence as that we were treated to on March 10, but surely it should be within the abilities of the

B.B.C. to provide such a programme at least occasionally. Unless they do this, the opinion will take root among listeners that if a really first-class programme is required it is necessary to look to some outside organisation to give it.

The B.B.C. is mistaken if it relies too much upon the proportion of

write letters. The average listener, whilst prepared to express his opinions quite freely among his friends, can be persuaded only with the greatest difficulty to put his views on paper. Although the Broadcasting Company have frequently asked for opinions by letter, it is only a great surge of feeling which will impel the average man to write to them.

On the other hand, the cranks, the ardent disciples of various cults, the propagandists, the adherents of strange faiths and the pseudo-superior people who praise anything that is beyond their mental grasp, are all willing to fill the letter-boxes of the B.B.C. at the slightest provocation. A large proportion of those who enjoy, for example, a Wagner concert, would be quite willing to write and say so, while admirers of the Savoy Bands do not all care to admit that they enjoy such music in preference to that of great composers.

A great deal of the criticism we have heard lately centres round the choice of the lectures and talks. In this particular field the B.B.C. should have an almost unhampered choice, yet in far too many cases the speakers are people unknown to listeners, speaking on subjects of very limited interest. Frequently, too, these talks take place at a time when light music would be better enjoyed, and it happens all too frequently that visitors arrive just as the news bulletins, weather forecasts and talks are beginning, and leave before they have finished, thus gaining the impression that broadcasting is, on the whole, a "dry-as-dust" affair, providing little that appeals to the average man or woman.

### CONTENTS

	Page
Forty Metres and Below .. ..	806
Radio Notes and News .. ..	810
A Condenser Unit for H.T. Batteries .. ..	811
Jottings By the Way .. ..	813
Electrical Measuring Instruments .. ..	815
An Air-Spaced Fixed Condenser .. ..	817
A High-Frequency Transformer for Single Stages .. ..	818
Reception Conditions Week by Week .. ..	821
Stability with Selectivity .. ..	822
An Improved Transmitters' Wave-meter .. ..	828
Correspondence .. ..	831
Apparatus We Have Tested .. ..	836
Information Department .. ..	839

letters received from those who like and those who do not like the programmes presented. With the huge army of listeners now making use of the entertainment facilities provided, there is no difficulty in getting praise for any kind of programme, and it must not be forgotten that the different sections of the listening public vary considerably in their inclination to

# Forty Metres and Below

By JOHN L. REINARTZ.



John L. Reinartz, IXAM.

**T**HE amateur is never satisfied long; his receiver, his transmitter or the wavelength is always being changed. This is just as it should be if the wireless art is to advance. Who can say that the amateur is not responsible for some of its progress? And now it seems that the amateur may again be useful while exploring the short waves below 40 metres. A year has passed during which 1XAM has, with the co-operation of the Naval Research Laboratory at Bellevue and a host of amateurs, explored the regions below 40 metres. Great credit is due Dr. Hoyt A. Taylor, Leo. C. Young, H. T. Dalrymple, 8XC, Can. 9AV, Can. 3BP, 4XE, 9AXX, 9EK, 9DFH, 6TS and others whom I may not have mentioned, but who in many ways have helped me to obtain the information which I was seeking, the results of which are very interesting.

### The First 50-Metre Tests

Soon after communicating with France on 100 metres, the next thing to do was to see just how far down it was possible to go and still maintain two-way contact. The farthest drop was to 50 metres, with PCII in Holland, who reported the signals during the test as being better than 60,

70, or 100 metres, PCII also being able to drop to 78 metres and still stay in perfect contact with 1XAM. Soon after that PCII got into trouble with the Dutch Government and the tests stopped.

### Further Reductions

That not being a satisfactory situation, 1XAM got busy and broadcast the information that short-wave tests would be conducted with any station which would be willing to test. The first station to comply was 8CU (now 8XC), who spent many hours recording test signals on 40 metres. Then word was received that the Naval Research Laboratory at Bellevue, D.C., under the direction of Dr. H. A. Taylor, wished to do some work on waves in the region above 100 metres. Trial tests during the noon hour quickly proved that waves below 100 metres would come through much better than waves above 100 metres. By

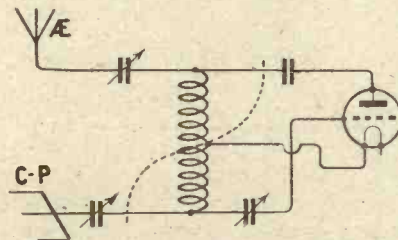

Fig. 1.—The circuit first used in 1923. It gave trouble, due to external high voltage at the valve elements.

March 26, 1924, the Naval Laboratory (NKF) had permanently dropped to 51 metres, while 1XAM had not lifted its head above 44 metres for some weeks, and was even creeping down a few metres daily, reaching 23 metres in one test on March 16, 1924.

### Strange Variations

Then began a series of tests lasting through the year, which seemed like a game of tag. One day 1XAM could go to 23 metres and be heard and another day only to 30 or 27 metres. At first cloud formations were blamed for the inability of the shorter wave to get to NKF, but now we know better; the sun is to blame.

### Sunlight Effects

The first inkling that the sun was going to make us sit up and take notice was when L. C. Young, the operator at NKF, reported that he could not find 1XAM at night when he attempted to listen while at his home. We decided at once to make a test from noon until night on March 29, 1924. The result was that NKF could be heard for a longer period after the sun had gone down than could 1XAM on 40 metres. This seemed odd and did not look just right, so other daylight to dark tests followed, but with the same result for all.

### New Allotments

On top of that, Mr. H. T. Dalrymple, of Akron, Ohio, began to report that he could find 1XAM on the shorter waves around 22 metres during the noon hour tests when NKF said nil, even remarking that perhaps NKF needed a good receiver, and to mix things up still more, 4XE reported that he could hear 1XAM perfectly after dark when NKF could not find a trace of the signals. When 9BRI reported the same results that 4XE did, we began to wonder and to think. By that time it was summer and the Department of Commerce decided to allow the amateur the use of 4 to 5, 20 to 22, 40 to 43 and 75 to 80 metres. Within a few months, thereafter, quite a number of amateurs got busy on the 40-metre band and more information

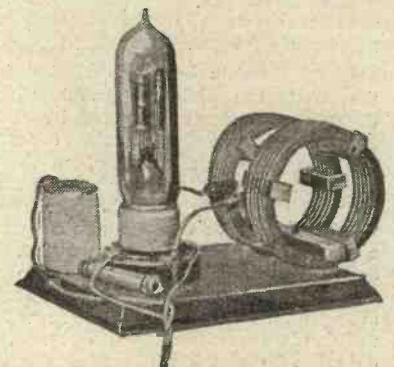

The 20-metre transmitter, including grid and plate inductance, plate choke coil and gridleak.

*Mr. Reinartz is as famous for his short-wave experiments as for his remarkable tuner circuits. This article describes a year's work in the fascinating realm of short-wave transmission. The circuits shown, are of course simplified, such details as filament resistances being omitted for clearness.*

was gathered, among which was that 1XAM could be heard by stations outside of a 500-mile radius at noon on 21 metres when NKF, 8XC and Dalrymple reported "no sigs." Also that the signals were being copied on the west coast and in Europe nightly from 7 to 8 p.m., EST., on 40 metres during which period 1XAM was sending test signals. To this were added 21 metres from 6 to 7 p.m., EST., from which nothing was heard. Taking all the past test information and piecing it together finally pointed to a solution.

**Wave Reflection**

Marconi in his work had pointed out that very short waves, less than one metre, could be reflected at will with the proper type of reflector, and at present is doing it on longer waves. This reflection is man-made. In our short-wave tests we were being troubled with reflection also, but it was due to the sun's influence and could be put to a useful service. I told you how the signals on 21 metres could be found at one distance, but not at a shorter distance. It must be that the short waves are at once propagated into our higher atmosphere, and upon reaching a given height are reflected from a layer of our atmosphere back to earth. The radius at which they are initially reflected is that place inside of the circle where the signal is a

minus quantity, and outside of which it can be found. The reason for this is the capability of the sun to ionize our atmosphere. The depth to which this ionization is possible depends on the position of the sun with respect to any locality on earth, changing with every position of the sun during 24 hours with respect to a transmitting station located at one place. Also, the shorter the wave the higher its initial reflecting height for the same time of day and, therefore, the greater its initial radius to which it is reflected on earth. As the sun goes west with respect to a transmitting station, the station has to use a longer and longer wave to maintain contact with a given station, say, 300 miles away. This was proved in tests with NKF, in which 1XAM had to move up the wavelength scale

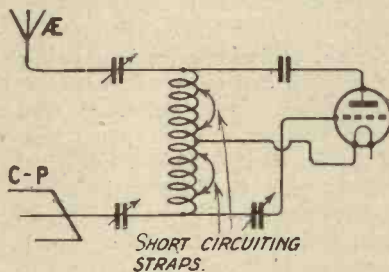

*Fig. 2.— Circuit used in the early part of 1924. A splendid circuit*

as the sun went down. The abruptness at which the shorter wave went out of range tended to show that it was at the same speed at which the sun was going west, only a second or two being the time between strong signals and no signals. Knowing that the very short waves are subject to absorption in a greater degree than are the long waves was then the reason why the short waves did not carry far when travelling over the earth's surface after being reflected from the higher atmosphere. Also it was evident that but little initial power was lost during this sojourn to and from the ionized layer so that by using the proper wavelength it would be possible to transmit to the west coast at noon EST. Acting upon this reasoning,

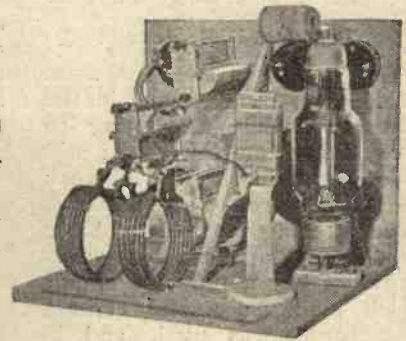

*The 250-watt short-wave transmitter.*

1XAM began to transmit on 20 metres each Sunday from 8 a.m. until 6 p.m., which bore fruit on December 21, 1924, when reports came from the west coast that three amateurs had copied 1XAM solid on 21 metres, in the meantime working 9EG and 9AXX and finally 6TS and 4XE at noon EST on 21 metres.

**Absorption at Short Wave-lengths**

Proof that absorption is great on the shorter waves is obtained from tests with 6TS, who cannot hear 1XAM until 7 p.m. EST. on 40 metres and who loses 1XAM on 20 metres at 6.30 p.m. EST. The 40-metre wave just comes near enough to gain sufficient strength to be received while the 20-metre wave is reaching that reflecting height which brings it back to earth at a radius which makes a greater circle than the bounds of the United States, and therefore beyond the west coast, probably reaching Australia soon after. And who can say that we will not be able to use such a proper wavelength and at the proper time of day which will allow contact with Australian amateurs while it is still early afternoon on the east coast of the United States? At present 6TS can copy 1XAM on 40 metres until 9.30 p.m. EST. This time will grow later as summer comes on and the sun reaches a higher point, gradually shortening as next winter approaches.

**The Transmitter Circuits**

Needless to say, the discoveries of the past year have been worth while, and should give the amateur a future right

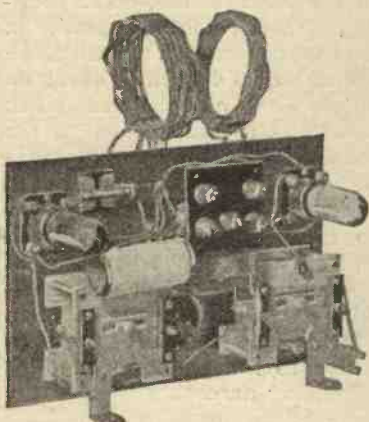

*A rear view of the short-wave receiver. Notice the low-loss condensers.*

to short waves, even if only to try out transmitting circuits.

**Practical Difficulties**

This brings us to the troubles that had to be overcome in the transmitter while attempting to make it oscillate lower and still lower until now the set will work on four metres with a 204-A valve, it being possible to obtain rated output at even that wavelength. For a time the circuit which made successful contact with Europe was used, and is illustrated in Fig. 1. This circuit worked very well to the 50-metre point with several valves in parallel, and down to 30 metres with single valves. Below that there was considerable trouble with excessive grid voltages and parasitic valve frequencies, which would break the valve insulation down very readily. Even the 204-A valve with its high insulation value was not capable of standing the strain for long periods of transmission; hysteresis losses in the glass supporting the grid mounting would

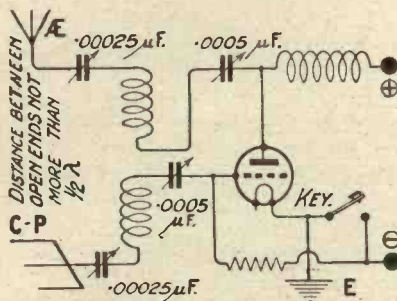

Fig. 3.—Final circuit which met requirements and will oscillate at less than 5 metres.

finally make the glass a conductor and a bad valve was the result. Evidently high voltage high frequency was responsible for that trouble, and in the endeavour to find a remedy it was reasoned that if a method could be found which would reduce the high-frequency voltage at the grid and plate element of the valve and yet allow proper operating conditions to exist, all the trouble would end. Various methods were tried, among which was one which, while not getting rid of the trouble, provided a circuit arrangement which tended to stabilise the frequency at which it was oscillating to the extent that any size or type or other variation in the radiating

system had no effect on its operation whatsoever; in fact, transmission through a two-wire cable 50 feet long to an aerial 50 feet from the transmitter was possible, and was actually done for long periods when in contact with NKF.

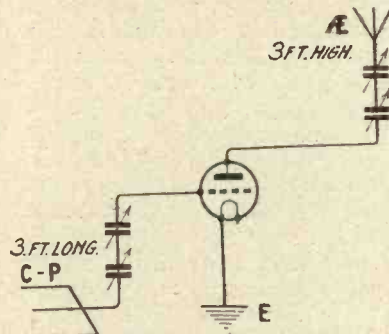

Fig. 3a.—The arrangement as used for less than 15 metres. The dimensions given are for 4 metres.

The frequency never shifted, whether the aerial was connected to one or the other wire in the cable; not even raising and lowering the aerial would cause the frequency to shift. This circuit is shown in Fig. 2. It will be noticed that the inductance to which the valve is connected is shunted in two places with a connection, this connection being equally spaced from the filament connection and shunting the same number of turns each side of the filament. This established full wavelength circuits, independent of the aerial or radiating circuit, and were in effect large tank circuits which, when connected to a radiating circuit which could not withdraw from this tank circuit as much energy as was being supplied to the tank circuit, would never have any effect on the frequency the tank circuit was operating at, nor did the radiation circuit have to be tuned to it.

**Improvised Circuit**

But this circuit did not get rid of the valve troubles, though it would oscillate at 10 metres. It was evident that any circuit which used an inductance to which was connected the filament and the grid and plate elements must always have a more or less high voltage at the grid and plate of the valve. What was wanted was a circuit which would allow the elements of the valve to be so connected that they were at nearly the potential of the filament with sufficient voltage for

proper operation. To find such a circuit, use was made of a dummy aerial system, low power and safe voltages. The circuit finally evolved met all these desirable conditions, and is shown in Fig. 3. It will be seen that the grid and plate are so connected that their potential is but little more than zero, the circuit being so proportioned that sufficient voltage is procured for the proper operation of the valve. The circuit adapts itself to either capacity or inductive coupling. In the former case the size of the aerial has very little to do with its operation other than that there must be not more than one-half wavelength spacing between the far ends or open ends of the radiation system for proper electro-static coupling. The radiating system being one condenser of the whole circuit, it can be nearly any length, experiments up to 80 feet long for the aerial and 65 feet long for the counterpoise having given excellent results on 20 metres, it merely being necessary to proportion the aerial and counterpoise so that they would have the same capa-

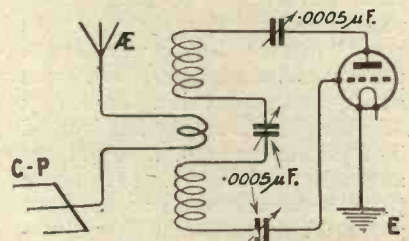

Fig. 3b.—An excellent circuit for short wave work.

city to earth, and being separated at the open or far end not more than one-half wavelength to obtain the proper electro-static coupling. The radiating system in this case is merely a capacity, the size of which has little effect on the wavelength of the transmitter as long as it is connected to the transmitter by a minimum capacity coupling which is not to exceed 100 μμF. If more capacity is used the aerial system will tend to alter the frequency at which the tube circuit was oscillating; this is made use of when it is desired to shift from 40 metres to the 75-metre band, it only being necessary to shift the value of the aerial and counterpoise condensers from the 50 μμF. value to 500 μμF., no

other adjustments being necessary. The aerial current is practically the same for any wavelength, if the input is kept constant, provided that the aerial system used has a fundamental wavelength greater than the highest wavelength that is to be used. That is, the radiating system should have a fundamental period above 80 metres, if the highest wave to be used is nearly that. If a radiating system is used, the period of which is less than the wavelength it is desired to use, the aerial current will differ with the different wavelengths when the input remains constant.

**The Inductances**

The inductances used in the circuit can be cut from the standard R.C.A. inductance, two sections of five turns each being suitable for the 20-metre band and two sections of 10 turns each being suitable for the 40- and 75-metre band. When it is desired to operate lower than 15 metres, the two 15-turn coils are removed entirely and the clips which were connected to the coils are connected to each other. A shorter aerial system is then desirable, as the radiating system is then in control of the frequency at which the valve will oscillate, there being no local circuit to determine the frequency, as the grid of the valve is connected by a short lead

to the counterpoise series condenser and from that directly to the counterpoise. Also, the plate of the valve is connected by a short lead directly to the plate blocking condenser, and from that by a short lead to the aerial series condenser, and from that directly to the aerial. The 4-metre band can be reached very readily when the aerial is a 3-foot vertical

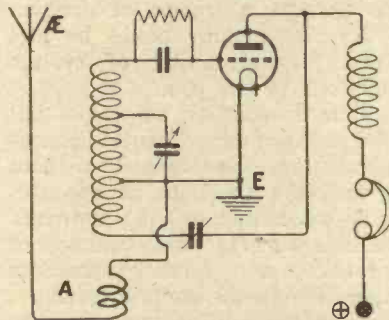

Fig. 4.—The short-wave receiving circuit. The manner in which coil A is connected increases selectivity. This coil in the improved Reinartz circuit was the aerial detuning coil, and in this case is used to couple the aerial coil to the tuner.

copper tube and the counterpoise is of the same length downward.

To use the circuit as an inductively-coupled circuit it is only necessary to substitute a variable condenser for the aerial and counterpoise, and coupling the radiating system to the oscillatory circuit, as shown in Fig. 3B.

**THE R.S.G.B. ANNUAL DINNER.**

**A Radio Conference**

We understand that over fifty nations, all interested in radio communication, have received from the State Department of the United States an invitation to attend the International Radio Conference, which is to be held in Washington, D.C., next September.

\* \* \*

The necessity of calling the World Radio Conference is due to the fact that the old regulations comprised in the London Convention of 1912 are inadequate to cope with communication problems brought out by the modern radio apparatus and the development of radio telephony and broadcasting.

It is important, therefore, for contracting parties to reach an agreement for the expeditious and efficient handling of radio messages which, if pursued according to the terms of present international law and regulations, would hamper considerably efficient traffic handling by radio.

Many important new laws and regulations are sure to emanate from this Conference, which will take in broadcasting, short and long waves, power for transmitters, amateur communication, and other points that have developed since 1912, with the onward progress of radio communication.



The Annual Dinner of the Radio Society of Great Britain, held at the Waldorf Hotel on Wednesday, March 4, was a very successful affair. Sir Oliver Lodge, the president, is seen seated in the middle, with Professor Eccles, past president, and Admiral Sir Henry Jackson on his right and left respectively.

# Radio Notes and News

*Some brief notes upon things in general, which are of special interest to wireless enthusiasts.*

**T**HE Radio Association, of which the Hon. Sir Arthur Stanley is the president, have addressed a memorandum to his Majesty's Postmaster-General on the subject of amendment to the Wireless Bill, in which they claim that the Bill does not sufficiently distinguish between the transmitter and the broadcast listener. The association appreciates the necessity for Government control of transmitters and the necessity of penalties in case of failure to observe the regulations in their case. They feel, however, that the large mass of ordinary licence-holders who simply receive the matter sent from the British Broadcasting Company and other stations are neither desirous nor capable of interfering to any appreciable extent with the convenience of others or inflicting any harm on any person or body. If this view is accepted it follows that the penalties which are contemplated in the case of transmitters who fail to observe the regulations are excessive when applied to the broadcast listener.

In cases of emergency, such as war, it is conceivable that listeners may be able in some way to become a source of danger. This contingency could be met by the transposition of certain sections of the Bill.

The association suggests that the grant of experimental licences should not be refused without giving the applicant an opportunity to submit to an approved examination in radio science or practice, and further considers the Bill should contain a clause giving the authorities power to compel persons or bodies wilfully interfering with broadcast reception to take such measures as may be required to put a stop to such interference.

\* \* \*

In addition, it is pointed out that the 1904 Act continued in force for two years only unless Parliament otherwise determined, and in view of the rapidity with which radio science is growing the association believe it would be desirable to limit the present Bill to two years with the same proviso.



*Mr. Stillman Kelley, the composer who set "Pilgrim's Progress" to music the miracle play which was S.B. from Covent Garden on March 12.*

We understand that, in a written reply to Sir H. Brittain, M.P., who asked what was the present position with regard to the Empire Wireless Chain, Sir W. Mitchell-Thomson (Postmaster-General) says that the high-power station which is in course of erection at Rugby is expected to be completed in about eight months' time. A smaller station for communication on the "beam" system, with a similar station in Canada, is expected to be completed in September or October next. Orders will be given for the erection of additional beam stations for communication with India, South Africa, and Australia as soon as definite arrangements have been made.

\* \* \*

A remarkable new wireless system, having features which are suggestive of a magazine story rather than real-life, is the Hale-Lyle, in which no telephone cords are used and the user can walk about the room with the 'phones on his head, listening to the broadcast programmes perfectly. The headphones externally resemble the conventional kind, and are worn in the usual way, and the receiving apparatus can be situated in any part of the house that may be convenient. Clubs in particular will welcome the invention, for the members can pick up a pair of 'phones whenever they like and sit or stand in any part of the room that suits them. Illustrations and full technical particulars are published in this month's *Wireless Constructor*.

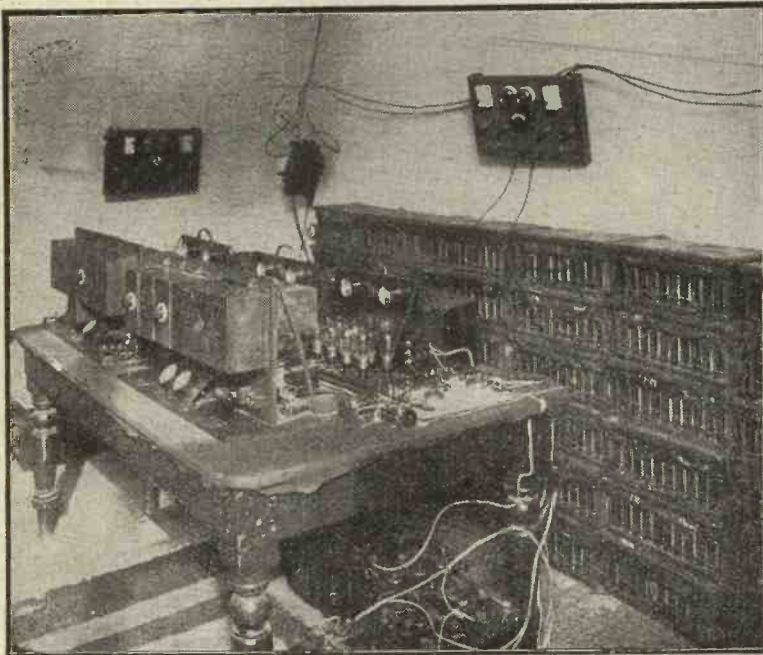

*The apparatus at the Ideal Home Exhibition, Olympia, London, which is used for receiving the B.B.C. programme.*



# A Condenser Unit for H.T. Batteries

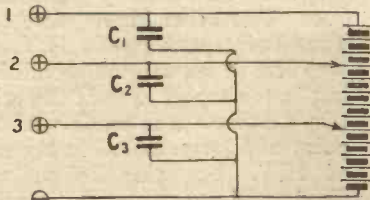

Fig. 1.—The idea illustrated in theoretical form.

A neat unit which may be used with any valve receiver with a view to avoiding expense in the purchasing of condensers for connecting across the H.T. terminals of every set.

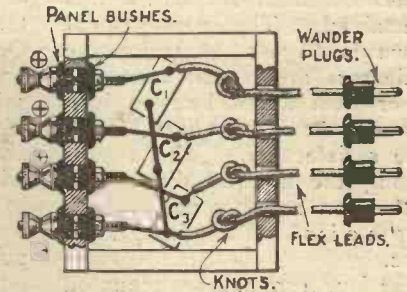

Fig. 2.—Showing how the unit should be wired up.

IT has been pointed out recently that it is an excellent plan to mount the high-tension battery condenser outside the set altogether. The reason for this suggestion is that it makes for convenience, since a single condenser will suffice for any number of receiving sets provided that the same high-tension voltage is used for all their valves. Besides reducing one's expenditure upon condensers this means that any set or "hook-up" can be tried out with the minimum of trouble, and with the assurance that there is a condenser in shunt with the high-tension supply. If there is already a condenser incorporated in a set under trial it does not matter in the least, for it means simply that the capacity across the high-tension battery is increased, which is all to the good.

### The Unit

The writer has lately made up a distributing box for the high-tension battery on the lines suggested by Mr. Percy W. Harris in an article in *Wireless Weekly*. This has proved to be a most useful fitting for the wireless table, and any experimenter who constructs it will find it a most handy addition to his outfit. The box, which is screwed to the underside of the wireless table close to one end, contains three condensers, each of two microfarads, and is provided with four terminals. The theoretical diagram is shown in Fig. 1. It will be seen that with the help of the distributor high-tension current can be supplied to the set at three different potentials, and that each portion of the battery is shunted

by a large capacity. It need hardly be pointed out that it is a very great advantage to be able to regulate the plate potentials of the various valves in the set instead of applying the same voltage to all. On the high-frequency side we require, as a rule, a voltage of between 60 and 80. The rectifier needs a much smaller plate voltage, and may be as low as 15 or 18, and will seldom exceed 50 or 60. Valves used as note-magnifiers usually do their best work with a high potential on their plates. It is a great mistake to imagine that a single condenser will suffice when several tappings are taken from the high-tension battery. If, for example, only the condenser marked C1 in Fig. 1 were, fitted

the portions of the battery lying between +2 and - and +3 and - would not have any capacity in shunt with them, and a single weak cell in either of these portions might lead to curious effects owing to the internal resistance of the battery.

The actual size of the box does not matter very greatly so long as it is large enough to contain the three condensers, which it is best to place at some distance from one another in order to simplify the construction and ease in making connections.

In this set were two note magnifying valves, the first of which was supplied by H.T. +2 and the second (a power valve) by H.T. +1. It was found that when the first note magnifier was

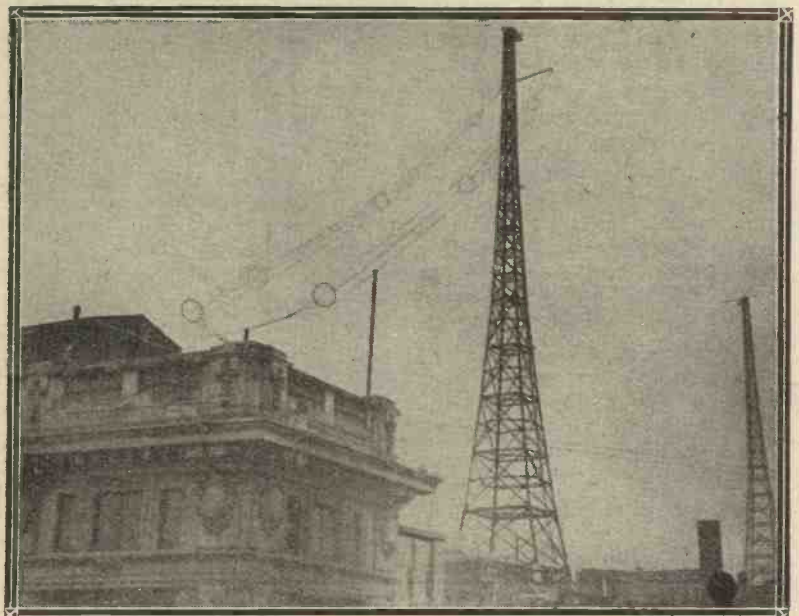

Our photograph shows the new aerial and masts at the new 2LO station situated in Oxford Street.

switched off signals were still quite strong in the telephones, and there were several other symptoms which appeared mysterious until the cause was ascertained. The arrangement shown in Fig. 2, in which the condensers are placed corner to corner with about half an inch between them has been found quite satisfactory. This means making the internal dimensions of the box roughly as follows: Length 9 ins., width 3 ins., depth 3 ins.

The four terminals are mounted by means of insulating panel

bushes on one side of the box. In the other side and directly opposite each of them holes are made of a size which will just allow the flex used for the battery leads to pass through them. One end of each of these leads is bared for about 2 ins. It is then soldered both to the upper contact of its condenser and to the shank of the positive terminal to which it belongs. A knot is tied in the flex inside the box so that should the lead be inadvertently pulled or jerked no strain will be put upon the soldered connection. The four wander plugs

must be marked in some way so as to make them easily distinguishable from one another. The writer's method of doing this was as follows. The negative plug was an ordinary plain black one. The other three were red. That corresponding to H.T. +1 was left in its original condition, but in the top of each of the other two a hollow was made with the point of a large drill. In the case of H.T. +2, this hollow was filled with green paint, white being used for H.T. +3.

R. W. H.

□ □ □

portion watched closely. After a few moments it will be seen to change colour, first going a faint yellow, changing to light brown, dark brown and purple. At this stage the heating should be discontinued for a moment, and if the shank is hot enough the heat will run into the point and the purple colour will change to a bright blue. The screwdriver should now be dipped into cold water; after this process it will be correctly tempered.

C. P. A.

## YOUR BROKEN SCREWDRIVER

WHEN working in the workshop the wireless experimenter may find himself with a broken screwdriver in his hand, which, on attempting to file it, proves to be dead hard, while no grindstone is handy, or at the best an oil-stone which will require a good deal of "elbow grease" applying before the screwdriver is again fit for use. The best way of putting the damaged screwdriver again into commission is to soften it first, after which it can very easily be filed. To do this heat the point in a gas-flame or fire till it is a cherry red, and allow it to cool off slowly. You can now file up the

edge to the right size and shape. Before using it again, however, it is necessary to harden it. The point should therefore be again raised to a cherry-red heat, and quenched out by dipping it into cold water. The driver is not yet ready for use, as it is much too hard and brittle, and the first time it is used on a recalcitrant screw it will break. The next process then is to "let it down."

### Tempering

Polish the point of the screwdriver with some emery cloth and heat the shank in a gas-flame about an inch and a half away from the point; this should be done carefully and the bright

### Tempering Steel Springs

IT is sometimes necessary to temper small steel springs that have had to be softened in order to drill or file them, and if they are of irregular shape the question of tempering them evenly may seem somewhat of a problem. This is easily done by letting them down in molten lead. The spring may be hardened in the usual way by quenching out in cold water from a bright red heat. Now melt some lead in an old iron ladle and dip in a small piece of polished steel. If, on withdrawing it, it is a bright blue colour the temperature of the lead is correct; if it has gone black it is too high, while if it is only dark brown or purple it is too low. If the lead is the right temperature, remove it from the flame or fire and drop the hardened spring in; leave it for a moment, then withdraw it from the lead. The spring should now be a bright blue colour, and will be correctly tempered.

C. P. A.



At a recent Wireless Exhibition in Newcastle a "Constructors' Competition" was held, and our photograph shows some of the competition entries.



## Jottings by the Way

### Wrath

**T**HOUGH you have not the good fortune to know General Blood Thunderby as intimately as I do, you are nevertheless sufficiently well acquainted with his character to enable you to realise that he is not the sort of man to have his freedom tampered with. When he first read the text of the proposed Wireless Bill, whilst sitting at breakfast at Simla Villa, I am told that a terrible scene ensued. As his eyes travelled down the column his face turned slowly from its normal ripe tomato colour first of all to that of raspberry jam and



*The thing is monstrous*

finally approached the rich shade of black currant tart. Rising to his feet—his young nephew, who is spending a few days with him, is my informant—he roared: "The thing is monstrous," bringing his hand down with a resounding thump upon the paper to emphasise his point. It was unfortunate that at the moment the paper should have been covering a dish of poached eggs. The contents of one of these fell upon Percy, the General's Alsatian, who, temporarily blinded and wondering who had hit him, promptly bit the first leg that he saw. The fact that the limb thus attacked belonged to the General had no calming effect upon the warrior. He became almost incoherent, raving disjointedly of dogs, Governments, eggs, tyranny, iniquitous bills, people

who put dishes under his papers, enslavers of the freeborn Englishman, and things of that kind. Even so I think that everything might have passed off well if he had avoided sesquipedalian words. As it was, in trying to get "unwarrantably anticonstitutional" off his chest all in one mouthful he partly dislocated his jaw, remaining open-mouthed and speechless. Thanks to the united efforts of Mrs. Blood Thunderby and the nephew, armed respectively with a boot-jack and a bed spanner, the jaw was eventually restored to its proper place, but as he had to go about for the best part of a week with his face in a sling the General was prevented for some time from expressing any further opinions upon the measure to be introduced into Parliament for the proper control of us terrible wireless folk.

### Terrible Fellows

Really, when you come to think of it, we must be a pretty tough crowd if a measure of this kind is necessary to keep us in order. What I mean to say is that if a fellow goes and blows another chap's head off with a gun the police do not walk straight into his house and demand to see his gun licence. They are extremely tactful about the matter, not inconveniencing him in any way until they are pretty sure of their ground. Or again, suppose that you possess a couple of dogs for which you ought to pay fifteen shillings in licences in January, you cannot be cast into prison for months and months, fined the price of a motor car, and have the bow-wows confiscated just to top things off. But, apparently, if you do not hand over your ten bob for a wireless licence much worse things than these may befall you.

In fact, failure to take out a receiving licence appears to be, in the eyes of those who drafted the Bill, a crime that is on a level with bigamy, issuing dud cheques, and mutiny on the high seas. Should this Bill ever become law, which Heaven forbid, I fear that Little Puddleton will be deprived of its "Wayfarer" for about six months every year. This is what happens to me. Mine is an experimental licence. (Swank.) On or about the 15th of June I receive from the Post Office a little slip requesting me to send the Postmaster a cheque for ten shillings. I always feel flattered by his willingness to accept my



*I shudder to think of the future*

cheque, and after leaving the slip lying about on the mantelpiece for a day or two I lose it. I think that some of the blue blood which flows in my veins must be of Spanish origin, for I am one of those who find to-morrow amongst the most beautiful of all words. I resolve that to-morrow I will send my cheque. And it goes on being to-morrow until I forget all about it. Then I get one of those nasty communications that puts my back up. You know the sort of thing I mean: "Pay up at once or you are for it." During the next two or three days I think out scathing covering letters to accompany my cheque, which is, of course, to be posted to-morrow. The months slip by, and one day, realising that I am a

pirate I borrow ten shillings from Poddleby and send it in. So far I have escaped the pains and penalties. The Postmaster and I have had our little tiffs, but it has never come to anything worse than that.

**The Future**

But I shudder to think what the future has in store. What will happen when June comes round with its seasonable snow storms? I shall receive my slip as heretofore. I shall place it on the mantelpiece. I shall say, "tomorrow I will send a cheque." And one day two or three weeks later, whilst I am essaying to tune in Timbuctoo or Pekin, I shall feel a heavy hand upon my shoulder. Turning round I shall find myself face to face with the majesty of the law as represented by P.C. Bottlesworth. He will ask for my licence. I will talk about the weather. He will produce the handcuffs. He will place them about my slender wrists; he will lead me to the local gaol, placing one hand upon my elbow whilst under the arm attached to the other he carries my wireless set. And the next morning I shall be dragged before the bench, who will fine me one hundred pounds. I will offer all that I possess in the shape of 2s. 3½d. and a bad half-crown, "found," as the *Little Puddleton Gazette* will have it, "upon the person of the accused." The bench will refuse to accept this, and I shall be cast into the dungeons. Yes, it is rather a terrible prospect.

**The General Once More**

As I have said, the General was unable for some time to tell us what he really thought about the matter, but as I was approaching the hut the other night the words "monstrous . . . unspeakable . . . disgusting . . . un-English . . . unheard of . . . attack upon liberty . . . mediæval despotism . . ." wafted to my ears made me realise that the warrior's jaw was once more in full working order. As I heard nothing more after "mediæval despotism" I feared that he might have suffered another dislocation and ran back home at top speed for the selection of suitable tools for dealing with such a crisis. However, when I arrived with a crowbar, a pair of gas pliers, and a monkey wrench

I was delighted to discover that all was well. "I am glad," I said as I stood in the doorway, "to find that my funds are unfeared . . . that is to say, to fear that my fiends are unfounded." They all stopped talking and looked at my array of weapons. Gubbworthy and Snaggsby advanced quietly and relieved me of them, whilst Poddleby, having apparently



*A rather terrible prospect*

caught the infection, remarked "that 'Wayfarer's' way appeared to be minding." When I had reassured them that all was well we settled down to business, and the General let himself go once more.

**A Gift**

Somebody once said that the most priceless of all gifts was that of self-expression. If the author of that beautiful thought could have heard our president express himself upon the Wireless Bill I believe that he would have received confirmation of his opinion. Possibly you have heard a master of foxhounds talking to one who has ridden over growing



*The General simply opens his mouth*

wheat. Possibly as a raw recruit during the Great War you may have come to learn what the sergeant-major's voice can do. Possibly again you may have been near a volcano when an eruption has been in progress. These things are pretty fierce, I admit, but compared with General Blood Thunderby's denunciation of the Wireless Bill they were as the coings of a sucking dove. The General simply opens his

mouth and lets himself go and you understand quite plainly whether he is or is not in favour of what he is talking about. On the occasion of which I am speaking we gathered that he was not in love with the Bill, its proposer, its seconder, its supporters, or those who would carry out its provisions should it become law.

**Poor Bottlesworth**

The fellow for whom I felt most sorry during the General's outburst was the unfortunate P.C. Bottlesworth, who has recently been elected a member of the club. As the president described at length exactly what he would do to anybody who tried to search his house for concealed wireless gear poor Bottlesworth aged visibly. A fervid appeal to the meeting to stand together as one man in the event of an intrusion and to deal, to say the least of it, faithfully with the intruder made Bottlesworth turn pale and his hair stand on end. But the worst was yet to come. At the end of his harangue the General suddenly spotted Bottlesworth.

**Intimidation**

Pointing a menacing finger at him he said, "And I observe that among the members present is one who will be called upon to carry out the directions of this iniquitous Bill. Let me tell you, Bottlesworth, that if you come to Simla Villa to examine officially my wireless gear I will push variable condensers down your throat, I will make you drink the contents of my accumulator, I will hang you from my aerial, and bury your body as an earth plate." Bottlesworth, I understand, has written to headquarters submitting his immediate resignation from the Force should the Wireless Bill become law. If he should go, I do not envy his successor.

**WIRELESS WAYFARER.**

**Broadcasting in Japan**

The much-heralded inauguration of broadcasting in Japan was arranged for March 1, and in preparation for it thousands of people bought receivers. At the last moment, however, the Communications Department refused authorisation.

# Electrical Measuring Instruments



A neat and useful voltmeter reading up to 100 volts.

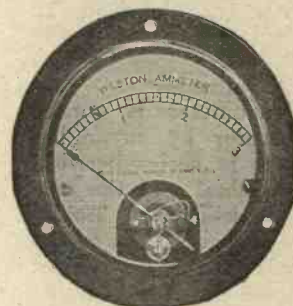

A typical ammeter used by amateurs.

Some notes upon the principles and construction of measuring ammeters, describing their advantages and disadvantages.

THE average wireless man uses, as a rule, only two classes of measuring instruments—the voltmeter and the ammeter. He may have two of the former, one arranged to read small E.M.F.'s such as that of the filament battery, and another capable of recording the voltage of the high-tension battery.

### General Use

Again, he may possess two or possibly three current-measuring instruments in the ammeter, the milliammeter and the microammeter. All of these, whatever the work they do, work on the same principle, they are simply calibrated galvanometers. The voltmeter, which is a shunt instrument, contains a fairly high resistance, whilst the ammeter, which is always placed in series, has comparatively low resistance windings, and is frequently provided with a shunt which carries the greater part of the current, and allows only a small proportion of it to enter the working part of the instrument.

### Moving Coil System

Good voltmeters and ammeters are made upon what is known as the *moving coil* system, whose working parts are shown in Figs. 1 and 2. Between the poles of a permanent magnet is fixed an iron cylinder, which concentrates the magnetic field. On each side of the magnet, and bridging the pole pieces, is a brass bracket which contains a jewelled bearing. Pivoted in these bearings, and arranged so that it can rotate in the small space between the core and the pole pieces, is a coil consisting of very fine wire wound round a

light metal frame (Fig. 2) of copper or aluminium. The pointer is attached to the pivot, so that it moves with the coil, whilst the hair-springs upon either side are arranged to oppose the movement of the coil and to hold it when no current is passing in such a position that the pointer rests upon the zero mark of the scale. Current entering

and its pointer clockwise, a reversal of the flow will bring about an anti-clockwise movement. When used simply as a galvanometer the moving coil instrument has usually a central zero position for the pointer, a movement of which to either side denotes the presence of current and indicates the direction in which it is flowing. Voltmeters and ammeters have generally the zero position at the left-hand end of the scale, one of the terminals being marked +. It will be seen that it is most important in the case of moving coil instruments always to connect them so that current flows through them in the correct way.

### An Ammeter

To turn the moving coil galvanometer into an ammeter all that is necessary is to provide it with a shunt to carry the greater portion of the current. The resistance of the windings and the shunt being constant, the same proportion of current will always be carried by the latter, and it is now quite a straightforward business to calibrate the scale so that it will show exactly the amount of current passed. By placing a large amount of fine wire upon the windings of the moving coil, the instrument can be made to give a full-scale deflection in response to a very small amount of current. If the shunt is made of high resistance, or is absent altogether, a very large proportion of the current, or the whole of it, will be carried by the windings. The instrument can then be calibrated as a microammeter or a milliammeter.

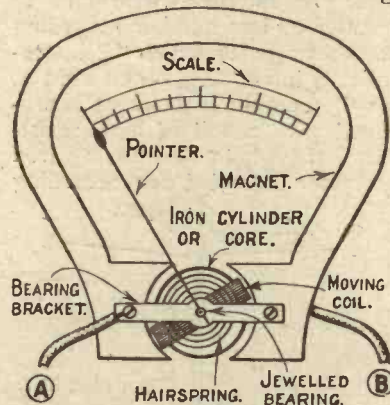

Fig. 1.—Principal working parts of a measuring instrument.

by the lead A in Fig. 1 is conveyed through the bracket and the hair-spring to the windings of the moving coil. It leaves then *via* the hair-spring on the far side and the lead B. When the coil is carrying current a magnetic field is set up round it, and it moves against the hair-springs in an endeavour to place its lines of magnetic force at right angles to those of the magnet. The heavier the current passing through the coil the greater will be the deflection, until a maximum point is reached. The direction of movement will depend upon that of the current. Thus if current entering at lead A moves the coil

**Heavy Currents**

With a shunt of low resistance only a small part of the current is delivered to the windings, and the instrument can be made to read the amperage of heavy currents.

**A Voltmeter**

The galvanometer is turned into a voltmeter by arranging the resistance in series between the input terminal and the corresponding hair-spring. As by Ohm's law the voltage across the terminals of the instrument is proportional to the current flowing and the resistance, the scale can now be calibrated to read the E.M.F. across two points of a circuit in which a voltmeter is placed in shunt. By varying the resistance the meter can be made to read either high or low voltages.

**Refined Instruments**

In all good moving-coil instruments the action of the pointer is very nearly dead beat. It does not flash past the proper reading and then swing to and fro for some time before coming to rest. This dead-beat action is the result of careful design, the principle being that when the metal former cuts across the magnetic field eddy currents are induced in it which oppose its motion and quickly bring it to rest (Fig. 2). The extreme lightness of the moving parts also assists in producing the dead-beat action. In really good instruments directly current is admitted the pointer swings smoothly to the correct reading and stays there. This is a very great advantage.

**Advantages**

The advantages of well-made moving coil instruments are these, a very great degree of accuracy, an evenly divided scale, and low current consumption. Their disadvantages are that the scale may often be comparatively short on account of the restricted movement of the coil; that they will not stand rough handling, and that their initial cost is rather high.

**Moving Iron System**

Cheaper instruments are made upon what is known as the *moving iron* system. In some types the current that flows between the terminals is utilised to create the magnetic field by being

passed through a fixed coil of wire. Within this are two small pieces of iron, one fixed and one attached to the spindle of the pointer. These two pieces of iron exercise a mutual repulsion when a magnetic field is set up by the passage of current flowing through the coil. As the amount of this repulsion depends upon

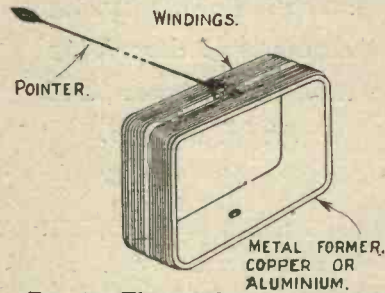

Fig. 2.—The windings and light metal former.

the flow of current, the scale over which the pointer moves can be calibrated to read in amperes or in volts. In the ammeter the whole of the current usually flows through the turns of wire forming the coil, which are made of finer or stouter wire and of greater or less number according to the range for which the instrument is intended. When used as a voltmeter the instrument is provided with a coil of high resistance, though in the moving iron ammeter intended for recording

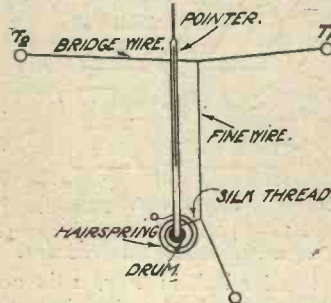

Fig. 3.—Showing principle of the hot wire ammeter.

the amperage of heavy currents it may consist of no more than a single turn of thick wire. The main advantage of the moving iron instrument is its low cost. Against these we must set a good many disadvantages. Moving iron instruments are not so accurate as those made on the moving coil system, and their scale divisions tend to close up on the lower readings, although in instruments of good design a practically uniform scale may be obtained. The cheaper instruments sold are not dead beat, but those

of good quality may be made sufficiently so for all ordinary purposes. The moving iron voltmeter is not satisfactory for taking high-tension battery readings, since its resistance is not usually high enough to cut down the current taken to reasonable proportions. As the battery cannot supply the current required by the instrument entirely misleading readings may be obtained with it. For obtaining a rough-and-ready idea of the current flowing in the filament circuits the ordinary cheap type of moving iron ammeter will answer quite well, and a voltmeter of the same type may be used for testing accumulators. It is best, however, in the end to purchase really good instruments which can always be relied upon to record accurately.

**Hot Wire Ammeter**

Another type of instrument, working on an entirely different principle, is the *hot wire* ammeter, which may be used for measuring either direct or alternating currents. The principle of this instrument is shown diagrammatically in Fig. 3. Current enters at terminal T1, and after passing through the bridging wire leaves at T2. Its passage causes this wire to heat up and to expand and sag. When this happens the fine wire connected to the bridging wire slackens, lessening the tension of the silk thread between it and the drum. This enables the hair-spring to assert itself, and the pointer is moved by its torque. The greater the current the more will the bridging wire sag, and therefore the greater will be the movement of the pointer. When current ceases to flow the bridging wire tautens and the pointer is returned to the zero position by the tension exerted by the fine wire on the silken thread which turns the drum against the hair-spring.

R. W. H.

**The Wireless Constructor.**  
APRIL ISSUE.

How to Build a  
**POWERFUL THREE-VALVE SET.**  
**TWO USEFUL AMPLIFIERS.**  
**A SINGLE-VALVE SHORT-WAVE SET**

FREE BLUEPRINT.

**BUY YOUR COPY TO-DAY.**

# An Air-Spaced Fixed Condenser

By C. P. ALLINSON.

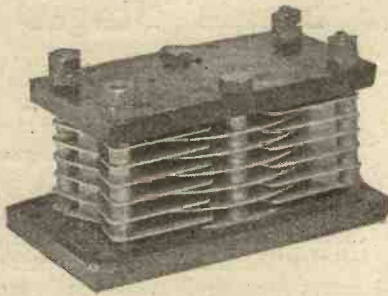

The completed condenser, though rather bulky, is strong and efficient.

The following article deals with the construction of a new type of fixed condenser which should appeal to those who are desirous of obtaining maximum efficiency.

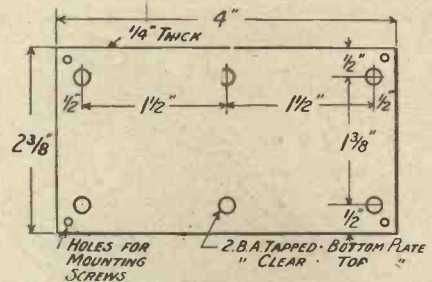

Each end plate is cut to the dimensions shown and afterwards drilled as indicated.

**M**ORE and more experimenters are turning their attention to the reception of short waves, and the ultimate aim for all instruments used for these high frequencies is that they should have the lowest possible losses. On this account there are many who would prefer to use fixed condensers with air dielectric. The drawing shows a simple method of making such a condenser from the fixed vanes of an ordinary variable condenser. These vanes can be obtained for a few pence a dozen.

### The Construction

Four short lengths of 2 B.A. screwed rod will also be required and some condenser spacing washers. Two pieces of ebonite 4 in. x 2 3/8 in. x 1/4 in. are also required. The construction of

this condenser is clearly shown in the figure, and the dimensioned sketch of the end plates will be useful for marking out the ebonite end plates.

One of these is drilled 2 B.A. and the other end plate should have 2 B.A. holes tapped in it into which the lengths of screwed rod are fixed, lock-nuts being run down and tightened so as to make a firm job of it. A condenser vane is then slipped down over two of the rods on one side and ordinary 2 B.A. washers placed on the other two lengths so that the vane which is slipped on them will be half the thickness of the condenser spacing washers above the first. The condenser can then be built up in the usual way so that alternate vanes interleave each other, and finally the other

end plate slipped on after having been levelled up with washers as found necessary, so that when the top nuts are tightened down the whole is quite firm without the two end plates being strained in any way. If the large spacing washers are used it will be found that 13 vanes will give an approximate capacity of .0001  $\mu$ F. Larger or smaller condensers can be made by using more or less vanes as required. If smaller spacing washers are used, not only will the condenser take up less room, but the capacity for a given number of plates will be greater. A .0001  $\mu$ F condenser may only require 7 or 9 vanes.

### An Improvement

In order to reduce the amount of solid dielectric in the field, holes may be drilled in the end plates. Only the best quality ebonite, of course, should be used, and if there is any doubt as to surface leakage it should be rubbed down with glass paper.

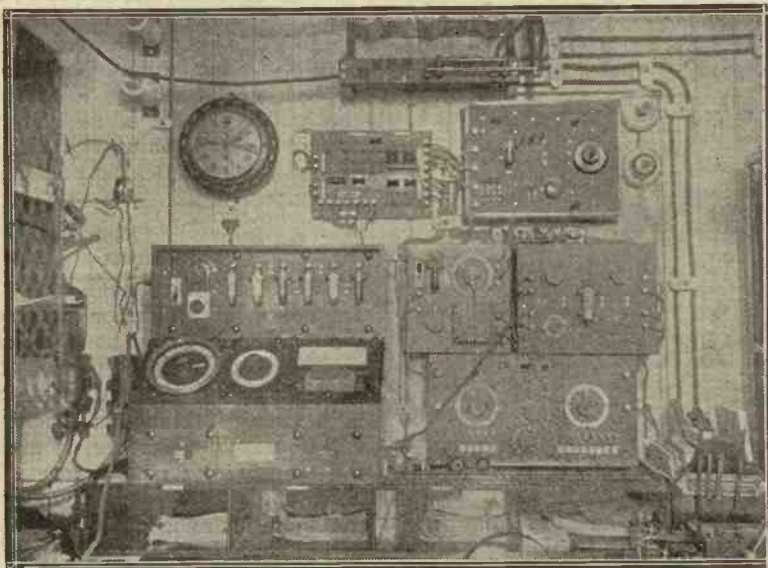

A typical receiving station on board ship. Note the D.F. apparatus on the left.

### A Popular Book of Sets.

No one who intends to build a new receiver should fail to obtain a copy of the latest Radio Press constructional book, by Stanley G. Rattee, M.I.R.E., Staff Editor, the sterling quality of whose designs is familiar to readers of "Wireless Weekly." Some of the best of his designs appear in this new volume, two of them being new ones, and all merit careful consideration.

### SIX SIMPLE SETS

By STANLEY G. RATTEE, M.I.R.E.  
Radio Press Series No. 21.  
Price 1/6, or post free 1/8.

# A High-Frequency Transformer for Single Stages

By G. P. KENDALL,  
B.Sc., Staff Editor

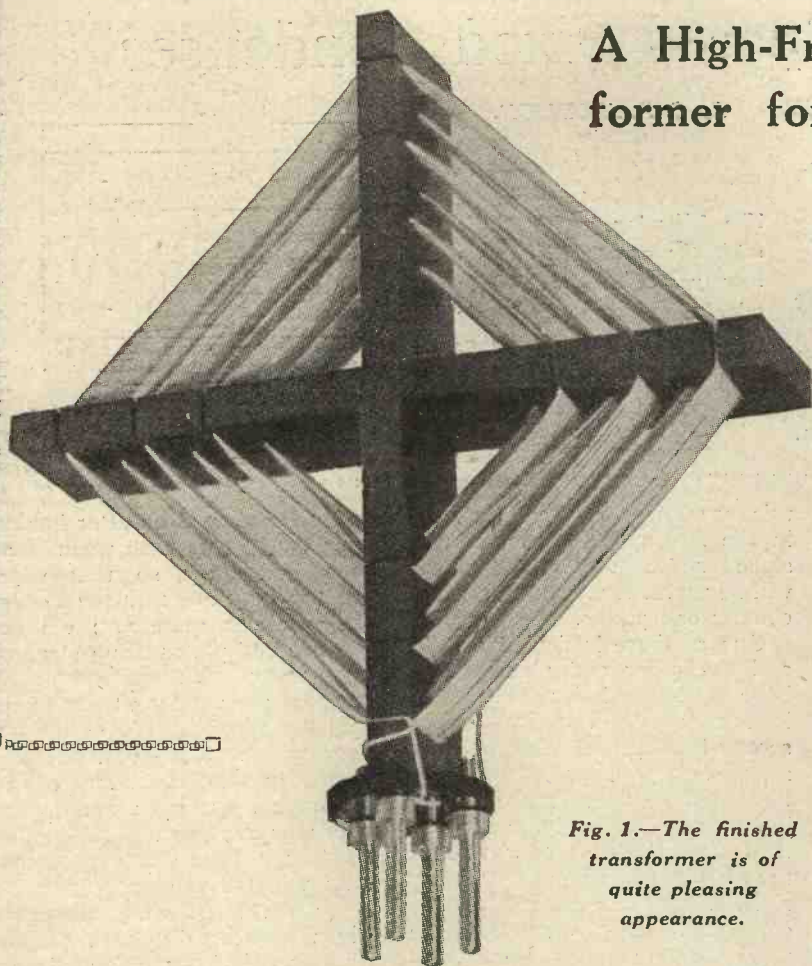

Fig. 1.—The finished transformer is of quite pleasing appearance.

vides the explanation of the somewhat puzzling fact that a set of the "Transatlantic" type may seem to oscillate much more readily upon long wavelengths than upon the shorter ones, which is, of course, contrary to expectation. This does not always take place, but when it does it is probable that it is due to the larger number of turns upon the long wave transformer producing a stronger magnetic field (with consequent more intense reaction effects) between two successive stages. It is therefore quite natural that designers of high-frequency transformers intended for use in all sorts of sets must devote a good deal of attention to the problem of making the transformer as small as possible, and the natural result is that the types with which we are familiar mostly incorporate windings of quite high ohmic resistance and very considerable self-capacity.

### High Efficiency Undesirable in Multi-stages

We cannot, therefore, expect them to behave in any way as efficient inductances, nor is it, indeed, desirable that they should do so when more than one stage of high-frequency amplification is to be used, if we are to keep a reasonable degree of stability in the receiver without the aid of special devices such as neutralising condensers.

### An Interesting Field for Experiment

Where only one stage of high-frequency amplification is used we find a somewhat different situation, since here it will be possible to sacrifice compactness to a considerable extent, and it will be possible, further, to make the transformer much more efficient when regarded from the tuning inductance point of view, without making the set seriously unstable as a result of stray coupling effects.

THE design of a high-frequency transformer, like that of most wireless appliances, is something of a compromise, since one has really to make an attempt to reconcile some quite opposing factors. One has, for example, all the usual considerations to take into account governing the construction of a good tuning inductance, but at the same time one must make allowance for unusually stringent requirements regarding compactness, limitation of stray fields, and so on. The result is that in the great majority of cases a high-frequency transformer is a distinctly inefficient piece of apparatus when regarded as an inductance, simply because it is necessary that it should be quite small and compact and that its stray field should be reasonably small, to reduce interaction between successive stages. This latter point is one which is of considerable importance and has a great deal to do with the

different behaviour of a set employing two or more high-frequency valves when different makes of plug-in transformer are tried.

### A Curious Phenomenon

It may be interesting to note in passing that this question of

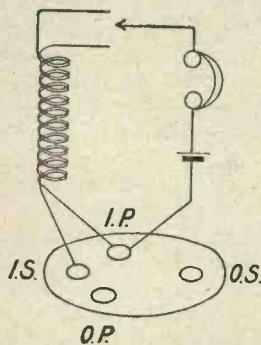

Fig. 2.—How to identify the ends of the windings.

the intensity of the magnetic field of a high-frequency transformer at any given distance from the instrument itself pro-



An interesting departure from the conventional form of plug-in transformer is described in this article. Readers of former issues will see how it has been evolved from the low-loss coils previously described.

**Design of Transformers for Single Stages**

The design of highly efficient intervalve transformers for use in sets employing only one high-frequency valve offers a very interesting field for experiment, and the particular transformer which is described in these notes is intended merely to represent one of many possible arrangements possessing desirable features. The basis of this transformer is the multi-layer cross-coil, which I described in a recent issue, and the result is certainly a coupling whose high-frequency efficiency is decidedly good. The capacity of the winding is kept quite reasonably low, and the gauge of wire employed may be sufficiently large to achieve reasonably low damping. The reader is advised to refer to the original article on this method of coil-winding for the exact details of the former employed, and it will be found that a very simple cross-shaped ebonite support for the windings is employed, which will serve equally well for the foundation of a transformer arrangement, such as that which we are now considering. (The issue of *Wireless Weekly* containing the original description was that of February 11, Vol. 5, No. 17.)

**Arrangement of Primary and Secondary**

A variety of possible arrangements present themselves for the insertion of the windings, and the one which I have found most suitable for the circuit in which I have tested this transformer is that in which both primary and secondary are wound on together, two bobbins of wire being employed, so that the two wires can be fed in simultaneously. This method of winding involves the maintenance of good insulation between primary and secondary, since if the covering of the

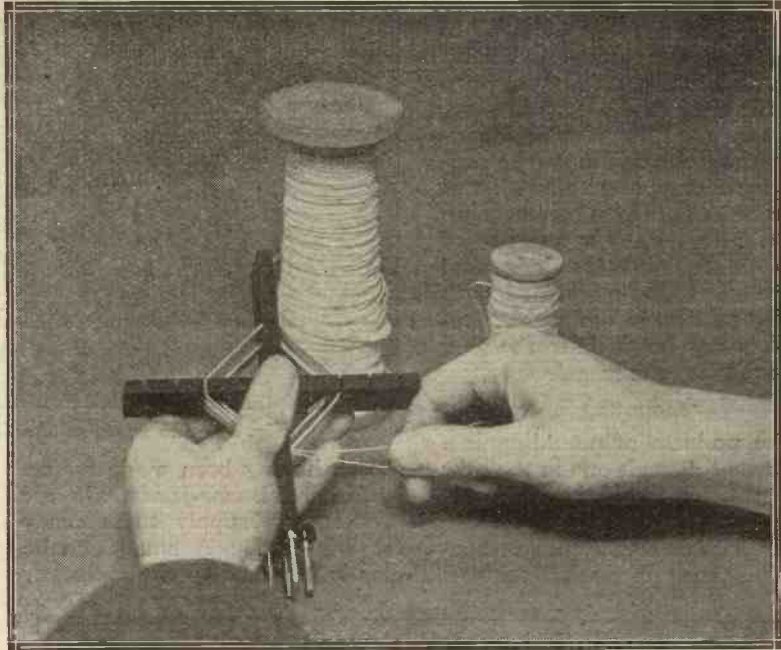

Fig. 3.—The winding is carried out with the aid of two bobbins of wire.

wire is not really dependable it is quite possible for shorts between primary and secondary to develop, with consequent injury to high-tension batteries and possibly valves. I therefore recommend that double-cotton-covered wire should be used, and that when the winding is complete it should be given a coat of moderately diluted shellac varnish, and then very thoroughly baked.

**The Winding**

The method of winding is extremely simple, being practically the same as that involved in the winding of an ordinary multi-layer coil upon one of these formers, the only difference being

an easy matter to run off, say, a quarter of a pound of it on to a spare bobbin, and then mount these two upon the workbench so that they are free to revolve easily, a convenient method of achieving this end being to drive two long wire nails a little way into the bench at suitable positions, upon which the two bobbins can be slipped. The wire used may be No. 28 or 30 double cotton covered, and the number of turns upon primary and secondary will depend, to some extent, upon the requirements and personal preferences of the experimenter.

**Turn Numbers**

Those who like to cover the band between 300 and 500 metres by the use of a transformer possessing a moderate number of turns and a fair-sized tuning condenser, such as a .0003 or .0005 microfarad capacity, will find that 60 turns primary and secondary will meet their requirements.

**Simultaneous Winding**

This is conveniently achieved by placing 10 turns of each winding in each layer, thus filling all the available spaces. In carrying out the actual wiring, a turn of each winding is slipped into the slot, a little practice enabling one

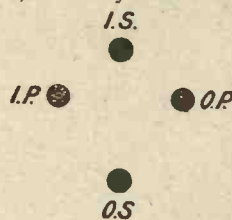

Fig. 4.—The standard connections of a high-frequency transformer.

that the winding is carried out, as it were, with a double wire which is fed from two bobbins.

**Use Two Bobbins of Wire**

If one obtains a suitable quantity of wire upon one bobbin, it is

to slip in the primary and secondary together, so that one carries out the winding with what is, to all intents and purposes, a twin wire. No pains need be taken to prevent these two wires crossing, since they will have to be identified at the conclusion of the process by a simple test which I will describe later. Upon commencing the winding, leave a free end of each wire about 6 ins. long, and at the conclusion a similar length should be left, in order that connection may be made to the plug mounting for the transformer.

#### Mounting

The problem of mounting is a somewhat difficult one in the case of a transformer of this type, but the method illustrated is one which I have found entirely successful, the particular formers

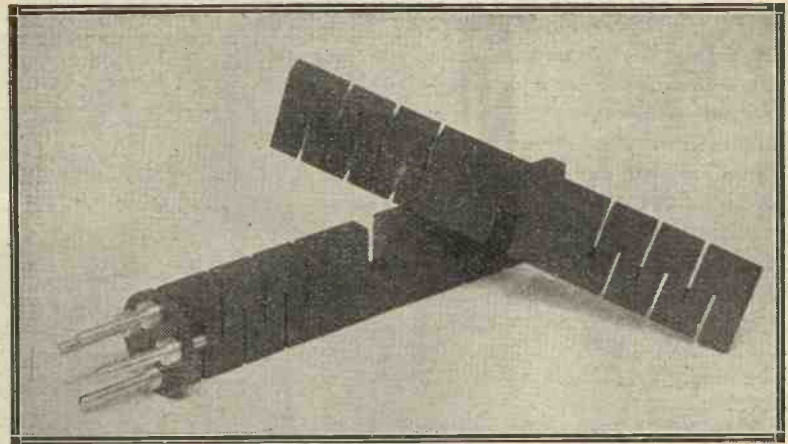

Fig. 5.—The parts of the former ready for assembly.

shown having been made for me by Messrs. Burne-Jones, who are prepared to supply them ready for winding. A small ebonite disc is attached to the extremity

of one of the arms, and in this disc the necessary four pins are mounted, two of them serving to attach the disc itself to the end of the cross arm. I find this method quite robust enough for practical purposes, since one does not expect such a component to stand up to very rough usage, and its appearance as a finished transformer is quite pleasing.

#### Connections

It is advisable to adopt the standard scheme of connections, and these are shown in one of the accompanying diagrams, which represents the four pins as seen when the transformer is held in the hand and one looks at them end on. When the winding has been completed the inner ends of the two are screwed down under the pins marked IS and IP, and one must then proceed to identify the equivalent outer ends in order that they may be connected beneath the pins marked OS and OP. This is very easily done by means of a pair of telephones and any convenient low-voltage battery, such as an ordinary dry cell, the connections being shown in another diagram. One tag of the 'phones may be connected to the battery, a lead being taken from the other pole of the battery to the IP pin of the transformer, and the other tag of the telephones is then touched upon the two outer ends of the winding until the one is found which gives a click. This is promptly connected under the OP terminal before one has time to confuse it with the other end, while the remaining one is tested in a similar manner to ascertain whether it is electrically con-

(Concluded on page 840)

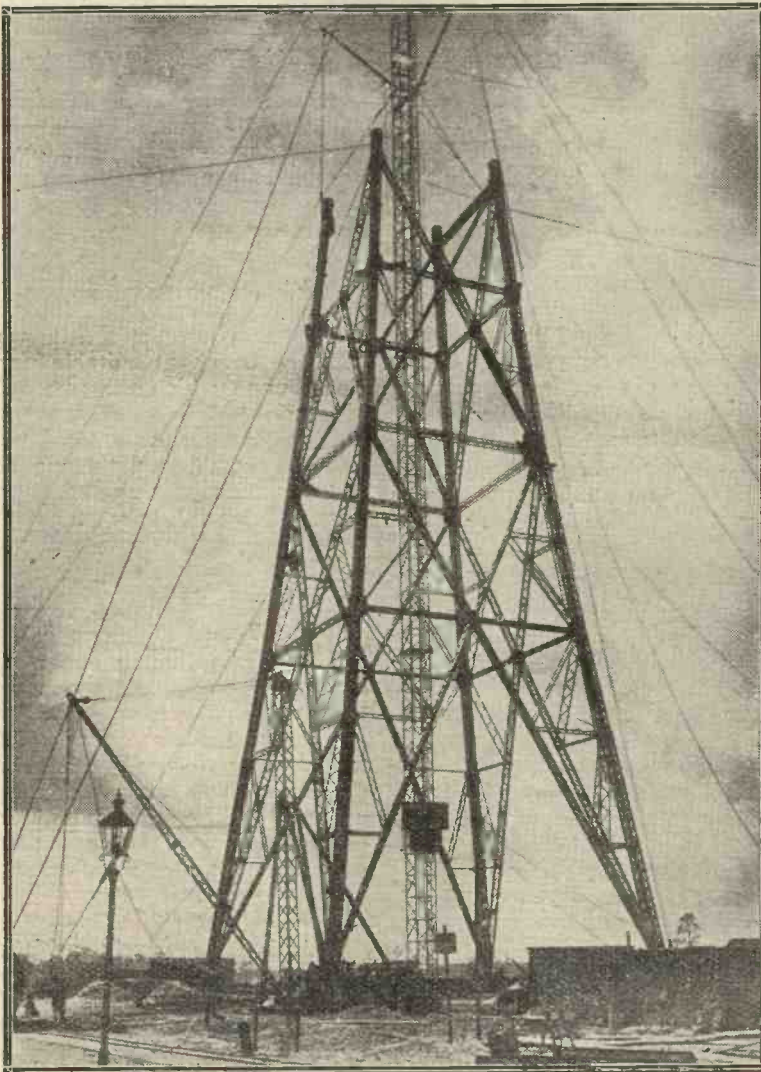

An elaborate mast construction which is being carried out at one of the Berlin stations.

# Reception Conditions Week by Week

By W. K. ALFORD.

Review of reception for week ending March 8th.

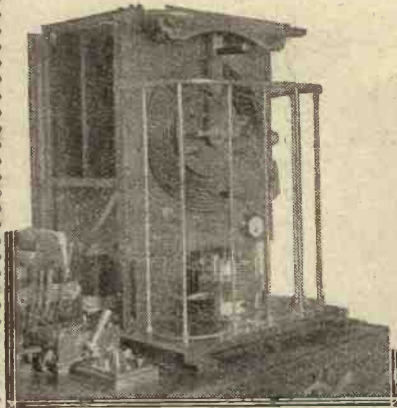

Spark transmitting apparatus on the s.s. "Maloja."

**I**N a previous discussion under this heading I mentioned, a few weeks ago, the impossible conditions for long distance reception which will be brought about by the overcrowding of stations on the broadcast band of wavelengths.

There is every indication, at the moment, that the apparent lack of co-operation among the various broadcasting services in Europe is rapidly bringing about this condition.

It must be noticed by every listener that hardly a night passes without one or other of the British stations being "heterodyned" by some foreign station. One can hardly believe that this sort of thing is deliberate, but there is no admissible excuse for it at present, and it should suffice to stir our responsible authorities to action before it gets too late to check the epidemic which has brought about the state of chaos which pervades the broadcast service in the States.

### Wavelength Allocations

Presumably, the broadcasting service is recognised by Government Departments in various countries as a public service, and requires to be worked under International Agreement just as the ordinary "telegraph" service, which, although it was apparently adequately protected under the Geneva agreement of some years ago, is beginning to need re-casting in the direction of wavelength allocation. The net effect of overcrowding of the broadcast

wavelengths is to limit reception to the "local" station whose signals, being very strong, are more or less immune from "heterodyning" by the weaker carrier-wave of a more distant station.

### The Need for Tolerance

Although nothing has been intimated publicly, the B.B.C. must certainly be looking forward to the time when great care must be exercised in any wavelength allocations, lest they burden themselves with a further opening for people to grumble at the service for matters outside their control.

Truly may it be said, that no commercial undertaking, in the history of the world, is so dependent for its success on circumstances outside its control as a broadcasting company, and it would be well if some of the "heavy-handed" and perfectly "unsinkable" critics would consider this very carefully before they embark on their tirades.

### The New 2LO

A point of interest during the week has been the preliminary testing of the new London station. As I anticipated in my remarks last week, very little difference is noticeable in strength, at 35 miles, between the new and the old station, although, of course, full power may not have been used. One very noticeable thing, however, is the increase in parasitic noise due to the longer land-line from the studio, which will be all the more noticeable, if not rectified, when simultaneous programmes are given from distant stations, as the line noises are already fairly troublesome.

A large number of listeners thoroughly enjoyed the re-transmission of 5XX by Pittsburg, KDKA, on Tuesday, March 3, about midnight and after. The whole thing was remarkably well done and reflects the greatest credit on the Westinghouse engineers.

(Continued on page 827.)

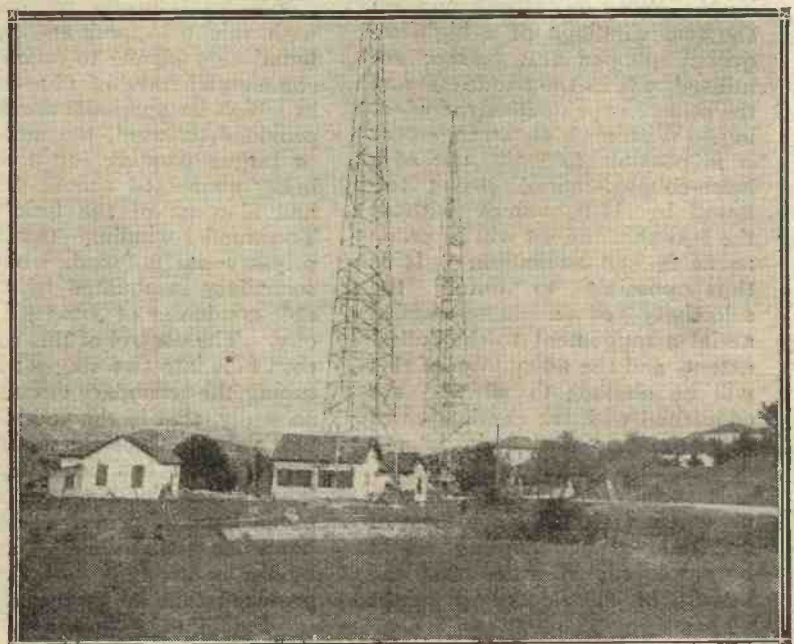

The new station at Tangier, Morocco.

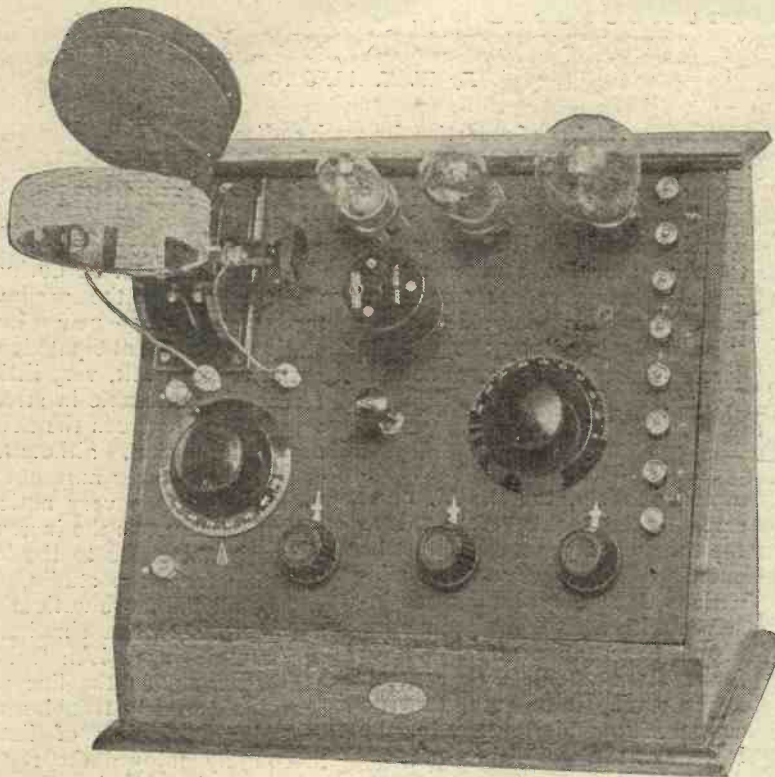

The receiver, when completed, presents a business-like yet distinctly pleasing appearance.

READERS of *Wireless Weekly* will need no introduction to the Cowper method of neutralising, and many will already be familiar with the modification suggested by Mr. Percy W. Harris wherein the two windings of a high-frequency plug-in transformer are utilised, one as the anode coil and the other as the neutrodyne winding. With such an arrangement it is possible to make use of a loose-coupled aerial circuit followed by H.F. valves without the fear that the set will be prone to fierce self-oscillation. It is thus possible to obtain the selectivity of a loose-coupled aerial arrangement to the fullest extent, and the advantage of this will be obvious to all who are concerned with the elimination of some station which it is not desired to receive.

It occurred recently to the present writer that some form of aperiodic aerial coupling might be employed, in order that the benefit of loose-coupling might

still be obtained and at the same time simplifying the number of tuning controls necessary.

**Tuning arrangements**

The present receiver is designed, therefore, to conform with this principle, and will be found very simple to operate. A commercial form of plug-in coil, in which an aperiodic winding is provided, is used, the secondary or larger winding of this coil being connected across the grid and filament of the first valve. The smaller winding—that is, the primary—is unfuned, while the secondary is shunted by a variable condenser of .0005  $\mu\text{F}$  capacity. The control of this receiver thus falls into two stages: firstly, tuning the secondary circuit, and, secondly, that in the anode of the first valve. Once the neutrodyne arrangement has been adjusted, it will remain constant for a given band of wavelengths, this band being that which is covered by the neutrodyne unit in use, provided that the high-frequency

Stability with

By JOHN

Neutrodyne receivers are popular, and below is a set in which the well-known neutrodyne is employed for frequency

amplifying valve or its H.T. voltage, are not altered.

**Panel Layout**

Looking at the photograph of the finished receiver, we see that the aerial and earth terminals are on the left of the panel. These terminals are connected internally to two Clix sockets, which are situated just below the coil-holder. Connection is made from these Clix sockets by means of flexible leads to the terminals on the side of the special aperiodic plug-in coil utilised. This coil is plugged into the fixed socket of the coil-holder, while the moving socket contains the reaction coil. Coming now to the row of terminals on the right of the receiver, the top two are for the telephones, the second one being positive, the next three terminals are for high-tension positives in the order of 3, 2, 1,

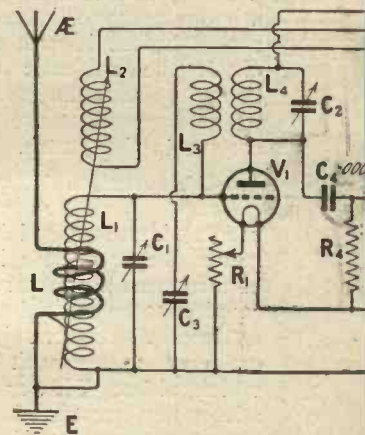

Fig. 1.—The theoretical circuit of a separate

# h Selectivity.

W. BARBER.

steadily achieving greater described a special 3-valve known Cowper method of by means of a plug-in high-transformer.

the next terminal is the high-tension negative, while the bottom pair of terminals are those to which the low-tension battery is connected. The three filament resistances are seen at the bottom of the panel, while the knob controlling the neutrodyne condenser will be seen below the plug-in neutrodyne unit. Another photograph given with this article shows the appearances of the set when the coils and valves of the set are removed, thus giving a clear idea of the layout.

### The Circuit Diagram

Fig. 1 shows the circuit arrangement of the receiver, and it will be seen that the aerial is joined to the aperiodic winding L on the coil L<sub>1</sub>, the latter being tuned by the variable condenser C<sub>1</sub>. The coil L<sub>4</sub> in the anode circuit of the first valve is one

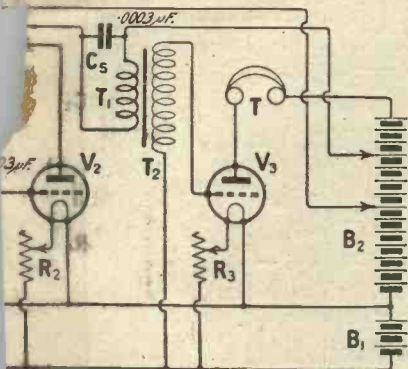

Magnum. Note that each valve has H.T. tapping.

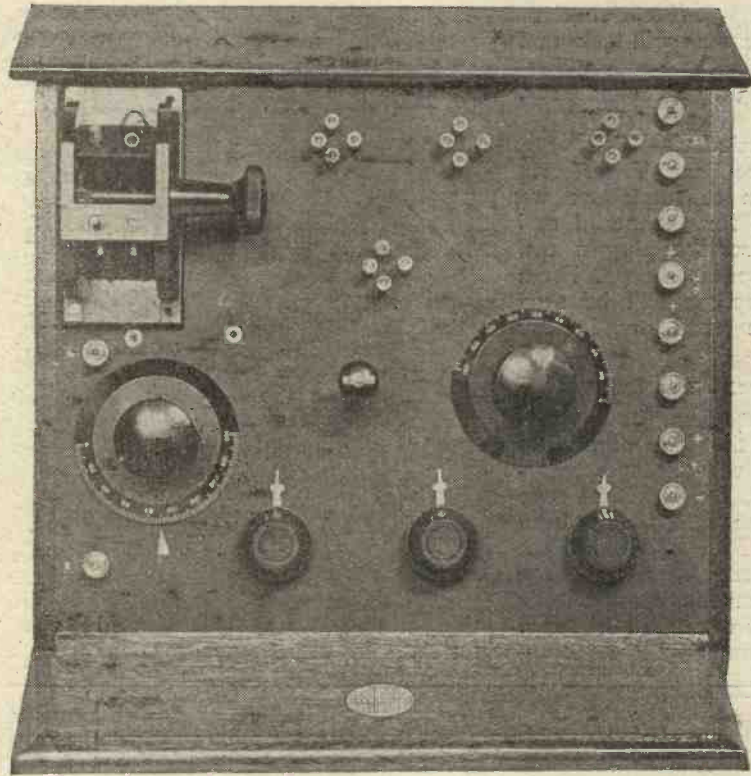

In this photograph the coils and valves have been removed to allow an accurate conception of the layout.

winding of the plug-in neutrodyne unit, the other being the neutrodyne winding L<sub>3</sub>, which is connected, one end to the grid of the first valve, and the other end to the fixed plate of the neutrodyne condenser C<sub>3</sub>, the moving vane of which is connected to the negative of the filament battery.

The second valve acts as a detector, reaction being provided for by the inclusion of the coil L<sub>2</sub> in the anode circuit, while the last valve is a transformer-coupled note-magnifier. A small condenser should be provided across the primary of the interval transformer in order to bypass the high-frequency component of the current in that circuit.

### List of Components Required

The following is a list of the parts used in this receiver, and for the benefit of those who wish exactly to duplicate it the names of manufacturers are given. It is understood, however, that this

information is only intended to serve as a guide, and that other makes of components may be substituted for those named, provided they are of good quality.

One ebonite panel, 12 in. x 10 in. x 1/4 in. (Peto Scott Red triangle.)

One cabinet of suitable size. In this case I have used a sloping front cabinet made by the Carrington Manufacturing Company.

One two-way coil-holder. (Burndept.)

One .0005 variable condenser. (Jackson Brothers.)

One .0003 variable condenser. (Jackson Brothers.)

One neutrodyne condenser. (Magnum.)

One neutrodyne unit. (Magnum.)

Three filament resistances. ("Royal," R. A. Rothermel, Ltd.)

Sixteen valve sockets, or, alternatively, four complete valve-holders. (Magnum.)

One low-frequency transformer. (Peto-Scott, Max-Amp.)

One .0003  $\mu$ F plug-in condenser and clips. (McMichael.)

One 2-megohm grid-leak and clips. (Dubilier.)

One .0003  $\mu$ F condenser. (Dubilier.)

Ten terminals.

Radio Press Panel Transfers.

In addition to the above we shall require for the aerial and secondary circuit a plug-in coil of the semi-aperiodic type. From the photograph it will be seen that I have used an Igranite Unitone.

Considerations in Layout

The layout has been considered from the point of view of compactness without overcrowding the parts, and it will be seen that appearance has not been sacrificed. Fig. 2 gives all the necessary dimensions, and the constructor can thus mark out his panel directly from this drawing. In order to simplify the construc-

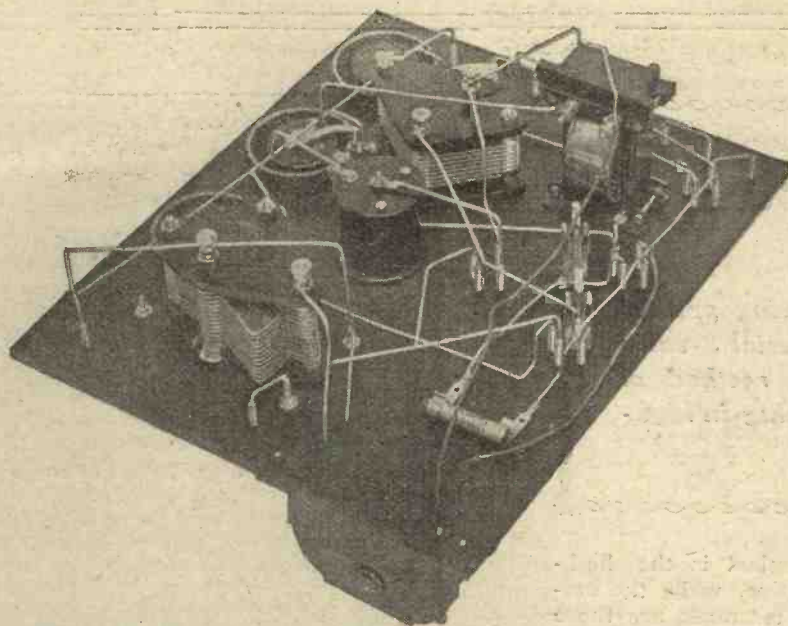

The relative heights of many of the wires may be gathered from this photograph, which also shows clearly the mounting of the grid leak.

tion, a template should be used for marking out the positions for the valve sockets, if separate sockets are used, and one of the

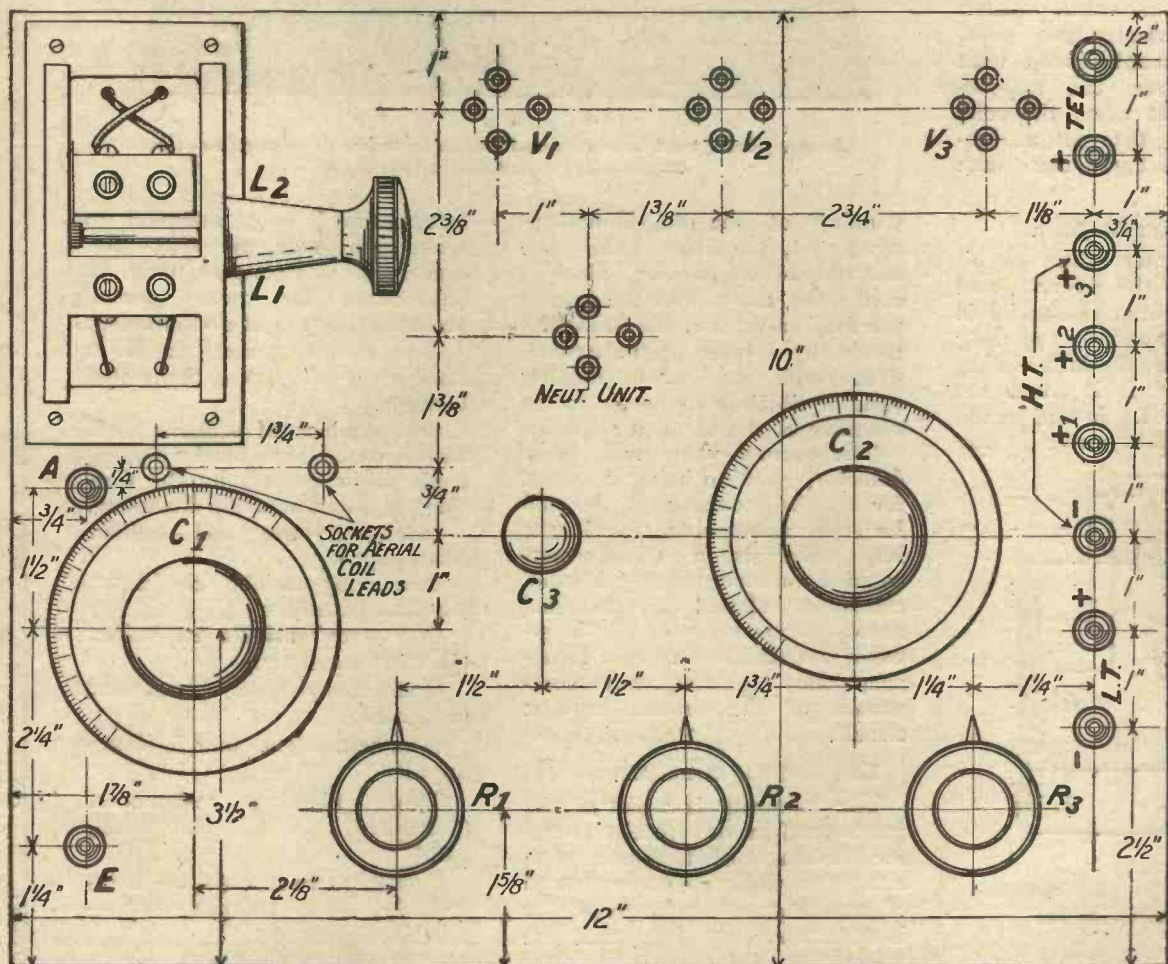
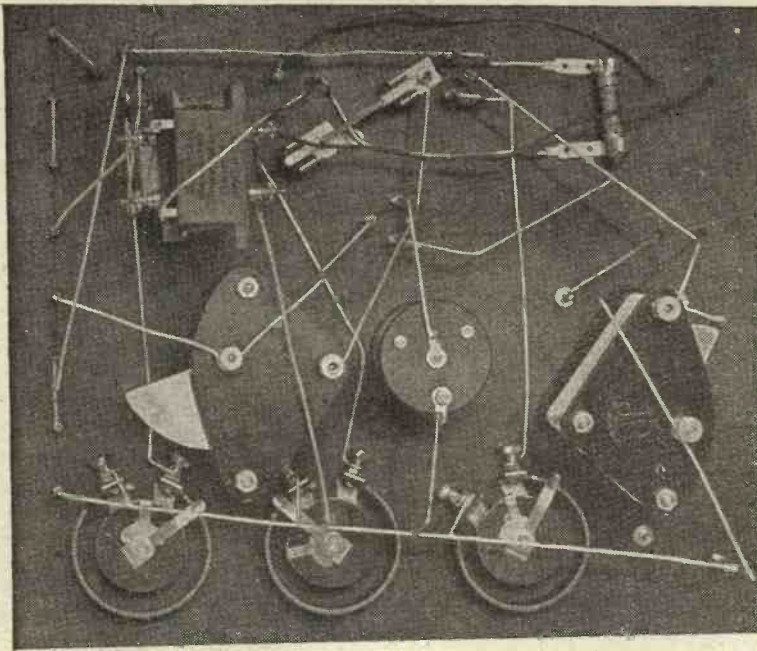

Fig. 2.—The drilling diagram. All necessary dimensions are given. If desired, a full-size blueprint may be obtained. Blueprint No. 104A should be quoted.



A helpful plan view of the wiring. If used in conjunction with the wiring diagram, all possibility of error is eliminated.

excellent commercial types, such as the Aermonic or the Morris, to mention only two, may be used. The template is placed on the panel in the desired position, given a light tap with a hammer, when it will be found that four marks have been made upon the panel in the correct position. It is then quite an easy matter to drill the necessary holes.

**Tapping in the Terminals**

It will be noticed from the back-of-panel photographs that the valve sockets and terminals are tapped into the panel, no nuts being used. This method of fixing these parts need not be adhered to if the constructor does not possess the necessary taps, in which case clearance holes should be drilled and the pieces secured by nuts on the underside of the panel.

The low-frequency transformer is secured to the panel by means

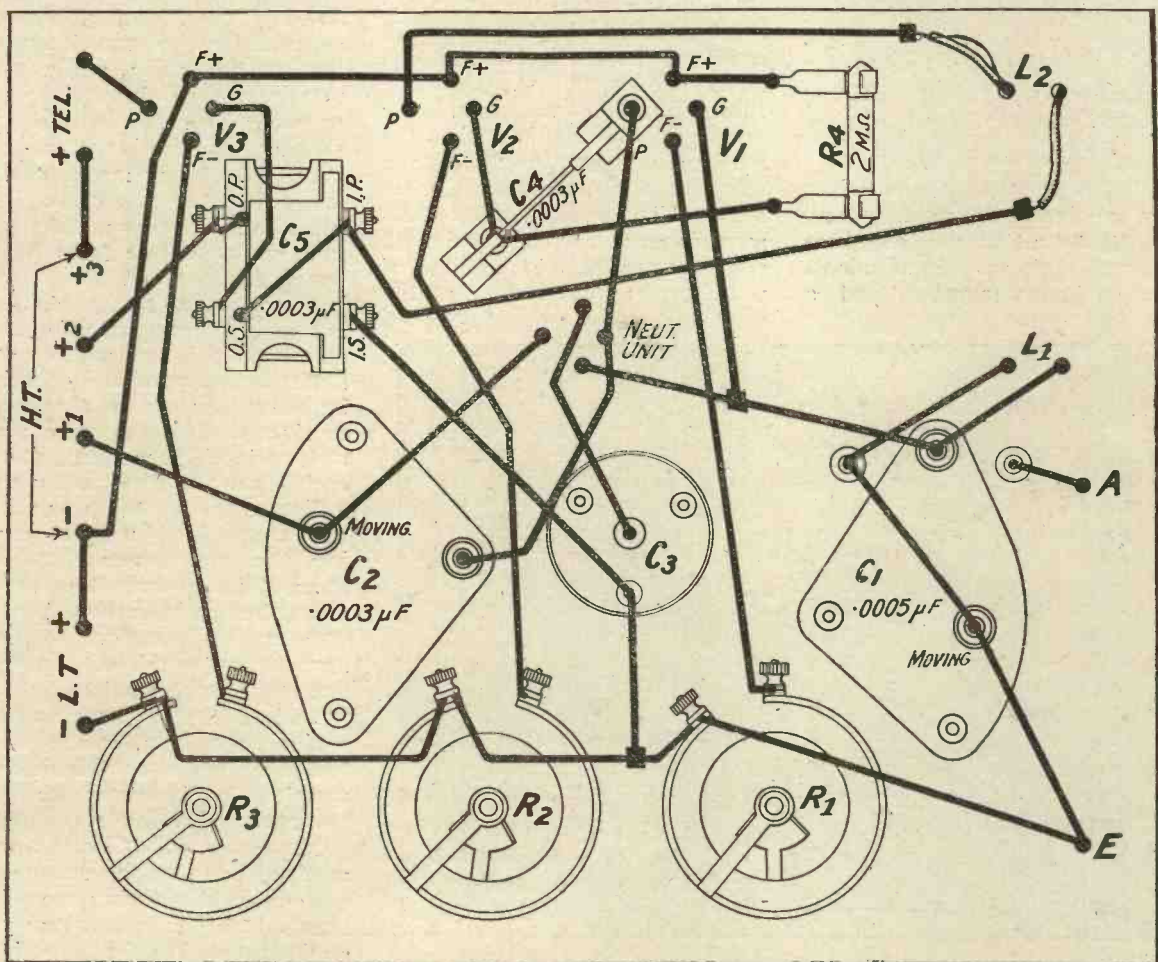

Fig. 3.—The wiring diagram, Blueprint No. 104B.

of "blind" holes, that is, holes which do not go right through the panel. The alternative method of drilling a clearance hole and countersinking it may be used, in which case bolts about  $\frac{3}{8}$  in. long will be required.

#### Mounting the Components

The components may then be mounted upon the panel, and this will present no difficulty. It may be noticed that the condenser dials are of a dissimilar nature to those supplied by the makers of the condensers named. This is actually the case, the dials used being known as the Collet dials, these being obtainable quite cheaply from most dealers.

#### Wiring the Receiver

When all the parts have been mounted in position, the wiring may be commenced. This is carried out with No. 16 tinned copper wire of round section, and the necessary connections will be quite easily followed from the wiring diagram. The back-of-panel photographs should also be consulted when wiring the receiver, in order that the different connections may be spaced to the best advantage.

#### Testing the Receiver

When complete the receiver may be joined up to an aerial and tested. As a first test, the three positive high-tension terminals may be joined together, and a

single lead taken from them to a tapping on the high-tension battery. The semi-aperiodic coil is put into the fixed socket of the coil-holder, and flexible leads are taken to the Clix sockets upon the panel. A suitable reaction coil is plugged into the moving socket. Almost any good general purpose type of receiving valve may be used in this receiver, and the filament and high-tension voltages should be adjusted to comply with the maker's directions. In order to adjust the neutrodyne condenser, the reaction coil L<sub>2</sub> should either be swung well away from the secondary coil, or replaced by a short-circuiting plug. The anode condenser is now moved over its scale, and it will then be noticed that the set will oscillate over a considerable portion of the dial. The stabilising condenser, which should, at the commencement, be in the minimum position, is then gradually turned, and it will be found that this adjustment will narrow the band over which the set will oscillate, as indicated on the anode condenser dial. Continue this adjustment very gradually until a point is reached when the receiver will not oscillate over any part of the anode condenser scale. The neutrodyne adjustment is now correct, and will remain constant for the band of wavelengths covered by the

neutrodyne unit. The reaction coil may now be replaced in its socket, and tuning is then effected in the ordinary way by variation of the aerial and anode tuning condensers. The receiver will be found to be very easily operated, and will provide many hours of fascinating work, owing to the fact that one is able to obtain the maximum from a high-frequency amplifying valve when operating in these conditions.

#### Results Obtained

The receiver was completed a few moments before the London station closed down upon a certain evening, and during the few moments that remained excellent loud-speaking signals were obtained from that station at a distance of five miles, south-east, the signals being clear and undistorted, whilst the majority of the unpleasant mush which is frequently obtained with high-frequency amplifiers was absent. Immediately after 2LO had closed down the condenser settings were adjusted to the wavelength of the Madrid station, and this station was then brought in at excellent strength in the loud-speaker. Reception was, however, not by any means perfect, as, owing to the host of local oscillators, one was unable to obtain reception free from heterodyne whistles.

On a further test in the early evening, Birmingham was received on the loudspeaker at a strength not previously obtained by the writer on a three-valve receiver without neutrodyne control, no interference being experienced from the London station at a distance of five miles on a high 100-ft. aerial. During the evening the programme from 5IT formed the principal entertainment, but at intervals Aberdeen was received at good 'phone strength, although at times an annoying spark station right on top of 2BD's wavelength utterly spoiled reception, there being less than 5 metres difference in wavelength between the two stations.

Newcastle and Glasgow were received during a subsequent evening, while during the Children's Hour transmissions five stations were heard but not identified, as no call signs are given on these occasions.



Our photograph shows Madame Tetrzini, who broadcast at the concert organised by the "Evening Standard," discussing the programme with Mr. A. R. Burrows, Director of Programmes.



**Reception Conditions  
Week by Week.**

(Concluded from page 821.)

**Relative Difficulties**

A great many people have spoken to me on the very much greater success which attended the experiment compared with the efforts of the B.B.C. to return the compliment and re-broadcast KDKA. In this respect, it is only fair to say that the difficulties in the two cases are not comparable

at all. Firstly, 5XX is a 25 kw. station, and was ostensibly using every one of them. Secondly, the conditions of reception are fairly stable on the wavelength of 5XX, and most unstable and difficult on 68 metres, on which wavelength the transmission of KDKA is taken before it is passed on to the transmitter. Lastly, as most experimenters realise, high-frequency amplification is a vastly different proposition on 1,600 metres than on 68 metres, and it was possible for the American

engineers to amplify the signals of 5XX to a very much greater degree, and with greater ease, than the B.B.C. could on the 68-metre transmission of KDKA.

**The Value of Relaying**

Nevertheless, these matters did not detract from the interest and value of the experiment in the least, and the outcome will undoubtedly strengthen the spirit of co-operation which will have such an important bearing on broadcast services in the future.

**A Rough Test for Small Condensers**

**F**EW experimenters are lucky enough to possess a means, such as the capacity bridge, of determining accurately the values of fixed condensers. So long as no components but those of thoroughly reliable make are purchased this does not matter very greatly, for condensers of well-known make seldom show a variation greater than 10 per cent of their stated value.

But it happens to all of us that we have occasionally to purchase a small fixed condenser of unknown make because we want one in a hurry and no other is available. Such condensers usually have a capacity which is anything but that claimed for them, and it is convenient to be able to test them roughly.

**An Approximate Method**

Here is a method which gives results sufficiently accurate for most purposes. To be able to use it, it is essential that the experimenter should possess a variable condenser of good make whose maximum capacity is known. It should *not* be of the square law type. Prepare a chart in the following way: On a piece of squared paper make a horizontal straight line, and mark it off into divisions representing, say, 0.0001  $\mu$ F. Draw a straight line at right angles to this, making on it divisions corresponding to condenser scale degrees. Opposite the 180 deg. mark, and immediately above the division corresponding to the

condenser's maximum, make a dot. Take its minimum as about 5 per cent. of the maximum, and make a second dot opposite the 0 deg. mark to represent this. Join the two dots by ruling a straight line between them. Your chart will now show you *roughly* the capacity for any dial setting.

Make up a simple crystal set, placing the condenser under test in parallel with the inductance in the circuit. With the wavemeter ascertain the wavelength to which the circuit is tuned. Now remove the fixed condenser, replacing it with the variable.

Tune the circuit until it is in resonance with the wavemeter, and read off from your chart the amount of capacity needed to produce this result. You can then tell approximately what the capacity of the fixed condenser is.

R. W. H.



Lord Riddell, who recently broadcast from 2LO.



*The instrument is quite self-contained and adds to the appearance of the instrument table.*

# An Improved Transmitters' Wavemeter

By PERCY W. HARRIS, M.I.R.E., Assistant Editor.

cannot be particularly accurate, and I have found the best method of calibrating the instrument is to induce in it from a separate oscillator or heterodyne wavemeter already calibrated as a receiving wavemeter, currents which can be rectified by the crystal and give a visible indication. In such a

convenient to have the cords hanging about the table. For this reason I substituted for the telephones on the original instrument an iron core choke which I had by me, and which had been used for experiments with choke amplification.

### No External Connections

By screwing this on the front of the box and connecting two short leads to the telephone terminals the wavemeter became much more compact. The original crystal detector used proved quite as satisfactory as most, but with the advent of a new R.I. permanent crystal detector, I lost no time in substituting this for the old form. Not only did one gain the advantage of stability of adjustment, but I immediately noticed the tuning became much

A FEW months ago (in *Wireless Weekly* for October 29, 1924) I described some experiments with transmitting wavemeter circuits and the construction of the instrument I finally decided upon. This has given me excellent service, and I am pleased to know that a number of readers have built this instrument with much satisfaction to themselves. As I have recently re-built the instrument in a considerably improved form, using practically the same parts, and as, moreover, the finished instrument matches the special form of receiver described in last week's issue, it occurred to me that a few notes upon it would not be out of place.

### The Circuit

To save reference back to the previous article, I am reproducing in Fig. 1 the circuit used. It will be seen that the oscillatory currents set up in the circuit formed by the coil and variable condenser are rectified by means of a crystal detector and passed through a Weston galvanometer, a pair of telephones being included for the double purpose of providing a choke and enabling aural calibration to be given to the instrument when a suitable buzzer wavemeter is available. The calibration of such an instrument by a buzzer wavemeter

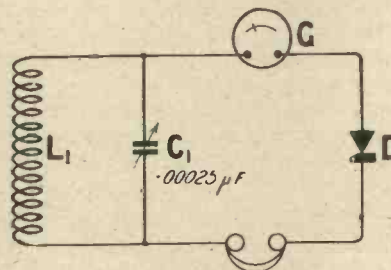

*Fig. 1.—The circuit adopted.*

case the telephones are used only as a choke, and it is not always

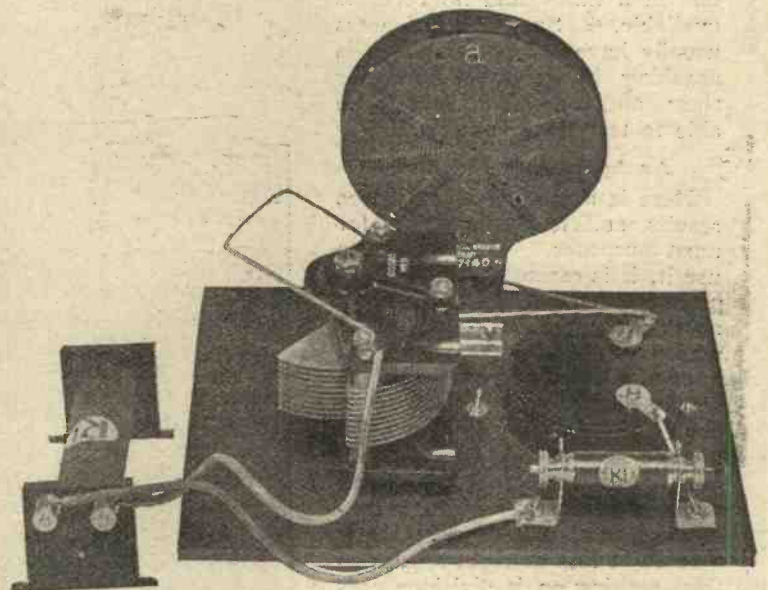

*The panel removed from the cabinet and the choke coil standing alongside. This latter is screwed to the interior of the cabinet on reassembly.*

*It is a well known fact that the use of neat and compact apparatus encourages and facilitates accurate experimenting. This article describes an improved form of the wavemeter Mr. Harris has previously described.*

sharper, due to the particular form of rectifying minerals used.

**Crystal Inside**

Furthermore, there was no longer any necessity for the crystal detector to be outside the instrument so that both the choke and the crystal could be placed inside without any disadvantage. It immediately occurred to me to rebuild the apparatus on a vertical panel in such a way that the choke coil and crystal detector were all inside, and as there are no terminals for exterior connections,

all that need appear on the front of the panel were the dial of the condenser and the scale of the galvanometer.

**One Panel Only**

For convenience of construction an endeavour was made to mount all the components on the one ebonite panel, but it was found that without making the box unduly large it was not convenient to place the choke upon the same panel. For this reason it was attached to the back of the box and two flexible leads from the front panel taken to it. A

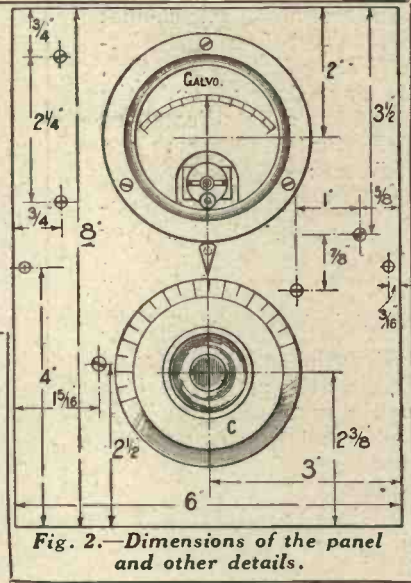

Fig. 2.—Dimensions of the panel and other details.

coil socket, facing inwards, is so placed that when the box stands on the table the coil is held in a vertical plane and thus will pick up currents from the transmitter with facility. In actual practice the wavemeter is kept two or three feet away from the transmitting apparatus, and is permanently in position on the right of the receiver, the cabinet of which matches in height and depth and general finish. Change of coils for different wavelength ranges is easily effected by lifting the lid and withdrawing the coil from the socket, substituting the desired coil in its place.

**Calibration**

As mentioned above, the calibration is best effected by bringing the transmitting wavemeter near to a calibrated receiving heterodyne wavemeter. At about a foot away there will be a deflection of several degrees of the galvanometer needle. In this way cross calibration from the receiving heterodyne wavemeter (described in *Wireless Weekly*, Vol. 3, No. 7) is very easily effected.

**Components**

The new crystal detector and the choke are both of R.I. manufacture, the square law condenser of .00025  $\mu$ F capacity is of

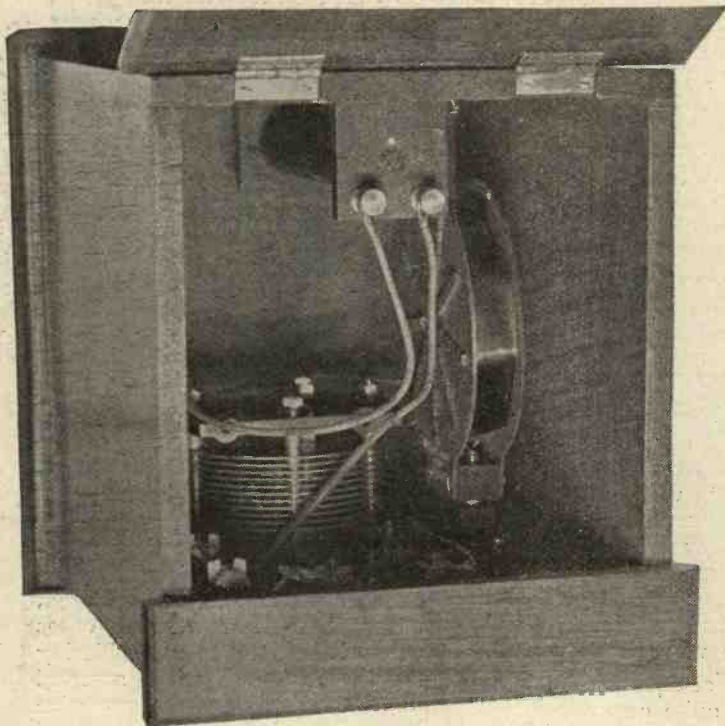

Looking down into the cabinet to show the position of the choke fixed to the back of the cabinet.

Sterling make, and the galvanometer is a Weston, while the coil socket is a Magnum. The cabinet can be obtained from the Carington Manufacturing Co., through any dealer, and the ebonite panel is a Peto-Scott Red Triangle. Suitable coils to use are as follows:—

For the 90 metre range a Gambrell small a, Burndep B, or other similar short-wave coils. For the 150 to 200 metre band a Gambrell A, Burndep S<sub>2</sub>, or similar coils. Suitable coils for any wavelength band can be found by consulting the makers' tables showing the tuning range with a .00025  $\mu$ F condenser in parallel, but without aerial or earth. In acting from these tables do not run too close to the makers' minima, as these are often "idealised" and for some reason or other are not always realisable in practice!

**High Tension from Flash Lamp Batteries**

**H**IGH-TENSION batteries can often be an expensive item of the wireless installation, and a great saving may be made by making up one's own batteries from flash-lamp refills when the set in use is not of the multi-valve type. Not only is this method very cheap, batteries at 4s. a dozen being quite suitable, but as the cells become exhausted it is an easy matter to remedy the fault by replacing defective cells by others.

It is best to solder all joints, as this does away with noises through bad contact between the connections. The long strips, which are negative, may be bent over, tinned, and connected to the shorter positive strips. It is most convenient to make up these batteries in batches of twelve, giving a nominal voltage of 54. If possible, the batteries should be dipped in paraffin wax before connecting up, as this prevents all chance of leakage, and also helps to hold the batteries in one solid block.

Clips similar to the old type of tie clips are suitable for taking tappings.

A. S. C.

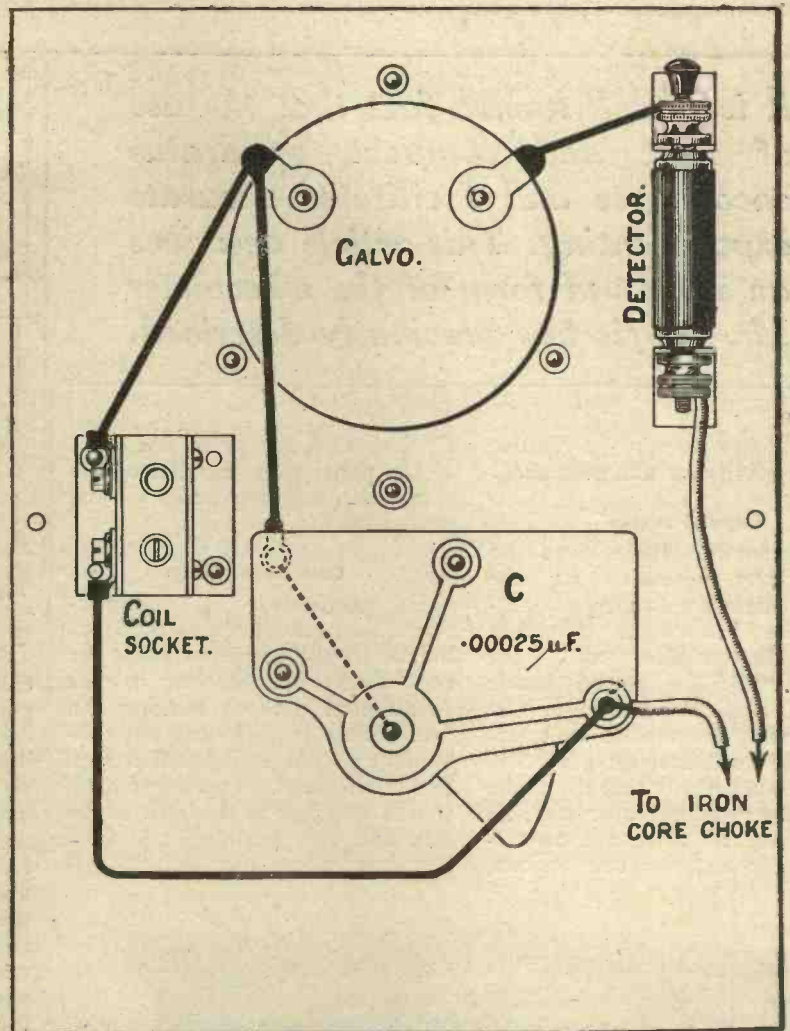

Wiring diagram to scale. Flexible leads go from the detector and the condenser fixed plates to the choke terminals.

**Methods of Wiring up Sets**

**T**HERE are in general use three different ways in which a set may be wired up, namely, with square-section wire, large-section round wire, and Systoflex wiring. The last method is perhaps the easiest in that, owing to the fact that the wire is insulated, shorting between two wires is prevented.

The use of square wire is now becoming quite common, and if this method is adopted the wire should be kept as straight as possible, and all bends should be right angles if good appearance is to be preserved. Good spat-

ing should always be paid attention to.

**Round Wire**

In the case of round wire the job of wiring is much the same, though perhaps quicker, as the wire may be bent by hand. Spacing should still be attended to as before.

There is no doubt that whatever type of wiring is utilised all connections should be soldered, except in a few special cases where it is better to use soldering tags. Although wires screwed under terminals and nut may give just as good results as soldered joints at first, they may give trouble later as a result of the nuts working loose.

A. S. C.

# Correspondence



## “THE FOREIGN RADIO TIMES.”

SIR,—I consider your *Foreign Radio Times* an absolute necessity, and am sure you will soon find a demand for increasing its scope.

Personally, I vote for the immediate inclusion of Madrid, a station which I enjoy frequently.

I don't want any stations cut out, but if quite necessary then cut out one of the German-speaking ones and include one of Spanish.

Wishing your enterprising paper the success it deserves.—Yours faithfully,

A. H. SAUNDERS.

Woodford Green.

SIR,—My purpose in writing to you is to compliment you on the list of foreign station transmissions published in *Wireless Weekly* of March 4. This is surely a new feature which will be of great interest to all listeners-in, and should therefore be worked out in all possible detail. I would therefore suggest that it would be well worth

while to devote as many pages to this feature as would be necessary to enable you to give the full programmes for the week. No other paper published in England gives so many particulars of foreign programmes as yours. I study daily the programmes given in *The Times*, the *Daily Mail* and *The Radio Times*, but I find many variations in these papers as to wavelengths of the stations, and the programmes are given in such a confused way that one has to waste a lot of time before getting a clear idea of the foreign programmes and their times.

Your paper, which I had before me on March 7, was a great help to my listening-in to foreign stations. I am sure your note that Zurich was giving some English songs would enlighten many people who thought they were hearing an English station.

I listened-in to all the stations of your programme on March 4

except America, and I think it would be useful and interesting if in future you could also give particulars for Brussels, Münster, Breslau, Stockholm and Frankfurt. Most of these stations come in in full strength.

May I suggest that in printing the programmes the stations should be arranged according to their wavelengths, i.e., from Brussels to Paris Eiffel Tower, and perhaps Königswursthäusen.

Please excuse me for asking so much, but as you invite suggestions I am taking the liberty of making this one, which I feel sure would be welcome to many listeners-in.—Yours faithfully,

P. TROWBERRY.

Bradford.

SIR,—As a regular reader of your paper, I should like to express my approbation of your new feature, *The Foreign Radio Times*, which, speaking for myself, and I am sure

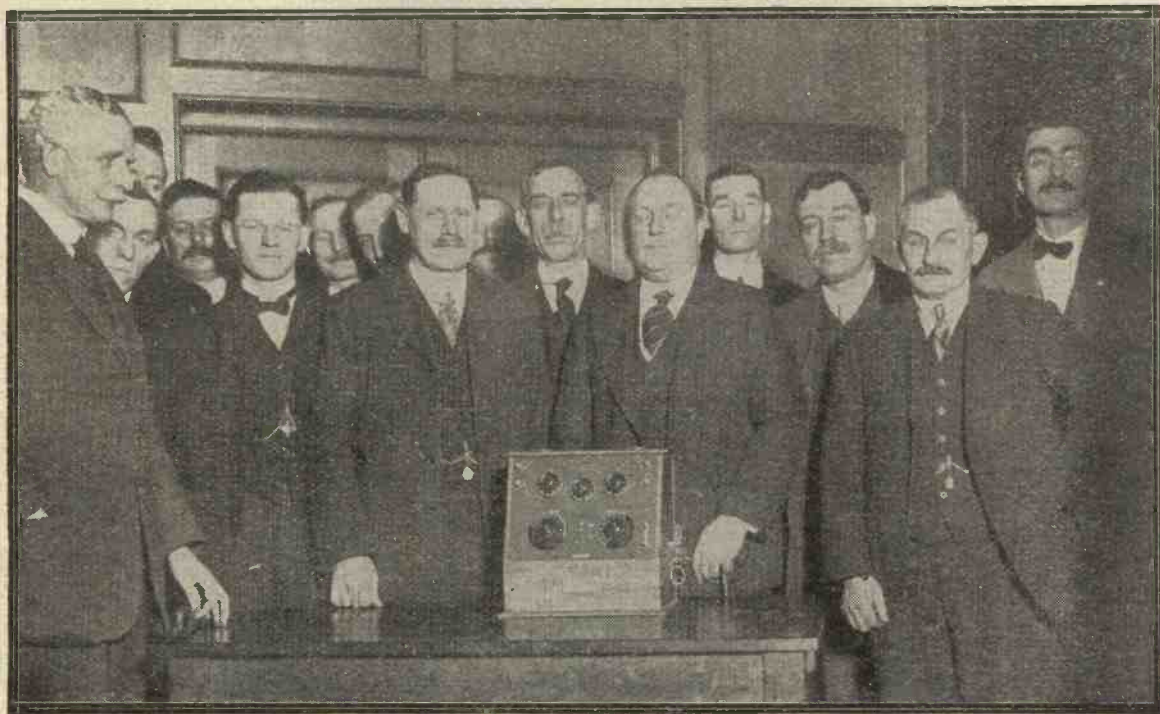

Sir Arthur Stanley (with walking stick) accepting a wireless set for St. Thomas's Hospital from the drivers and firemen of the Nine Elms Loco. Depot.

for many others, fulfils a long-felt want; but I should like to see included in the list the programmes of the following stations, which come through very well here: Radio-Belge, 265 metres; Hilversum (Holland), 1,060 metres; Madrid, 392 metres.

Also some of the German stations are very good, such as Munster, Breslau, etc.



A four-valve family receiver made by Mr. F. W. Wenham.

We find Radio-Paris is about our best foreign station, the German relays also coming in very well.

Our set is a home-made "All-Concert" three-valve and one-valve amplifier, as described by Mr. Harris in "12 Tested Wireless Sets," and we are very satisfied with it. Our "bag" includes some 30 odd Continental stations, and we can get all B.B.C. stations, main and relay, with the exception of Swansea.

We have also had U.S.A. several times, KDKA and WBZ coming through at excellent strength, and among others WGY and WOR.

Hoping you will continue this excellent feature, and wishing your paper every success.—Yours faithfully,

F. S. WALBURN.

Colwyn Bay.

SIR,—You ask for the opinions of readers with reference to the new feature, *The Foreign Radio Times*.

First of all let me say that I think that it is an excellent idea, and one that will be of great use to all readers. I have often wished that some such programmes could be obtained.

It strikes me, however, that the selection of stations is not the best. The four Paris stations everybody wants to know about, but I am not so sure about Vienna. Two serious omissions are Brussels (Radio-Belgique) and Madrid (Radio-Iberica). Both of these stations come in at good strength in this neighbourhood. Also with regard to the American programmes chosen, I should say that the ones wanted are KDKA, WBZ and WGY. Of the Continental stations Munster and Hilversum are also received in the North of England and might be included.

It will, of course, be far better when you can make arrangements to include the full week's programmes.

In conclusion, I should like to say that my set is a three-valve ("All-Concert") on an indoor aerial, and I can get all the Paris stations, Brussels, Hilversum, Madrid practically any night.—Yours faithfully,

J. H. S. JONES.

Chester.

SIR,—I am much interested in your *Foreign Radio Times* Supplement, and hope you will be able to extend it.

I read your three periodicals, *Wireless Weekly*, *Modern Wireless* and *The Wireless Constructor*, and am much interested in them. I might say that I have read each of them from the first number, and

have nothing but praise for the excellent circuits, etc., depicted and described. With regard to the Continental programme, I am sorry that SBR (Brussels) is not mentioned, as this is one of the best Continental transmissions in the North of Ireland so far as reception is concerned. Also, with regard to the American stations, I would suggest the inclusion of WBZ and WGY, both of which "come in" very well here.—Yours faithfully,

J. E. DAVIS.

Belfast.

SIR,—Referring to your new feature, *The Foreign Radio Times*, edited by Captain Plugge, I think you are to be congratulated on this exceedingly useful compendium of information.

The putting before listeners-in of the actual programmes of foreign stations is likely to give them far greater interest and enthusiasm for long-distance reception than the previously published bald information that news bulletins, concerts or talks were "on" at certain times. Indirectly the table given will probably call for improvements in the design and sales of really first-class apparatus for D.X. work and thus be a stimulant towards "better radio."

"The only improvement which one could suggest is that the usually employed call formula used by each station with phonetic equiva-

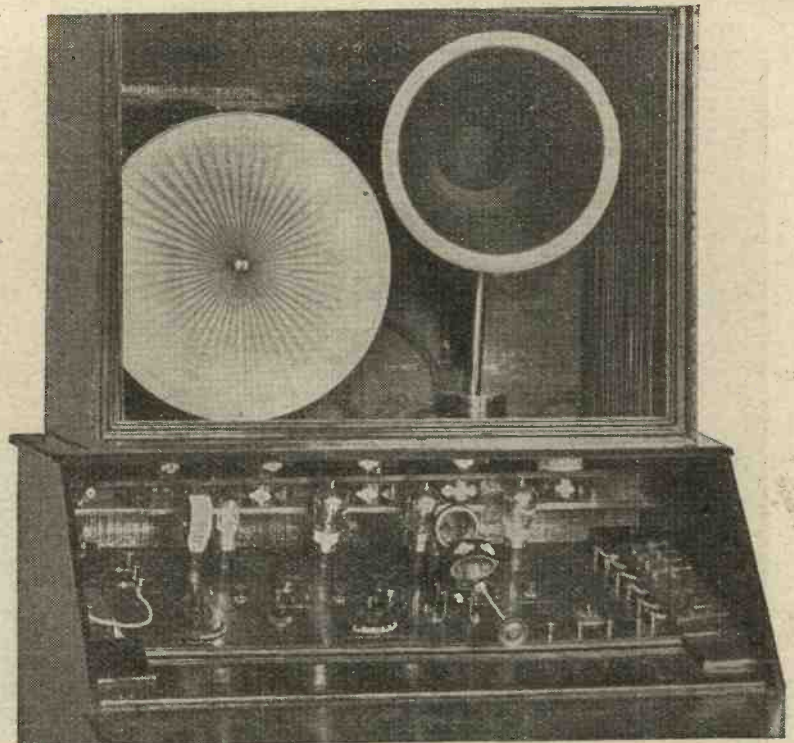

The loud speaker for use with Mr. Wenham's receiver is concealed behind the curtain seen in the former photograph.

lents ("Ici Radio Paris"—"Eesee Rahdeeh Pahree, etc.") should be printed with the other station information.—Yours faithfully,

W. J. RICKETS,  
A.M.I.E.E.

Peckham, S.E.15.

SIR,—I suggest that *The Foreign Radio Times* should be a real supplement and easily detachable from the main body of *Wireless Weekly*.

The Sunday programme should be as complete as possible.—Yours faithfully,

E. G.

Wateringbury.

SIR,—Congratulations on your enterprise, *The Foreign Radio Times*. This new feature will make *Wireless Weekly* more valuable than before, and may I suggest that Radio Belge be printed if possible?

Trusting you will continue *The Foreign Radio Times*.—Yours faithfully,

H. R. HARDIE.

Twyford, Berks.

SIR,—I would like to congratulate you on the excellent supplement appearing in *Wireless Weekly*. A paper such as *The Foreign Radio Times* has been a heart-felt need

for some time, and I am pleased to see that you have again been the first to realise the requirements of wireless amateurs in this country.

Wishing you all success with your untiring efforts.—Yours faithfully,

W. A. BAKER.

Brighton.

SIR,—I wish to congratulate you on again leading the way in the radio world by being first to publish complete foreign programmes. It seems to me to be a very great step and one which will be appreciated by numerous listeners-in who previously could not follow very accurately the announcement of programmes from foreign stations.

Wishing your new venture great success.—Yours faithfully,

M. D. ANDERSON.

Peckham, S.E.

SIR,—I am very interested to note your supplement in *Wireless Weekly*. I think it is a splendid addition to your already invaluable paper.

The wavelength and power of these Continental stations are specially useful, and I am now able to distinguish stations to which I have tuned in.

I am glad this supplement is a regular one, and wish it every success.—Yours faithfully,

H. STANLEY.

London, N.W.3.

INTERACTION BETWEEN AERIALS

SIR,—I was exceedingly interested in Mr. Harris's remarks in *Random Technicalities* regarding interaction between receivers and transmitters in the same room. I imagine this is the first notice the matter has received in any journal, and the problem is one that has interested me for some time.

Signal strength in a given receiver whose abilities are known does vary periodically, as also does the selectivity achievable. One is, perhaps, a little too prone to blame, say, 2LO for varying their power input when these changes take place.

Experiments very similar to Mr. Harris's have led me to the conclusion that interaction is to blame for a good many phenomena of this sort that are usually put down to some entirely different source. Very curious results can be experienced when a house is wired throughout with a system of loudspeakers, as is my own. One experiment I have tried is to tune the aerial lead in and then place several sets in the same room and in

Another Guaranteed BRETWOOD Speciality is our improved ANODE RESISTANCE

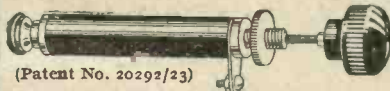

(Patent No. 20292/23)

which gives accurate readings consistently from 10,000 ohms to over 100,000 ohms. This BRETWOOD Component is particularly suited for the STrooc circuit (*Modern Wireless*), the super-sensitive circuit (*Popular Wireless*), and for resistance coupling, etc.

It is constructed on the same principles that have made BRETWOOD Components famous, and, of course, it carries the BRETWOOD Guarantee. Price 3s. Postage 3d.

**BRETWOOD LTD.,**  
12-18, London Mews, Maple Street,  
London, W.

All Bretwood specialities are obtainable from most Wireless Dealers.



**BRETWOOD GRID LEAK.**  
Patent No. 224295.

Used and recommended everywhere.  
Price 3/- Postage 3d.

**BRETWOOD PATENT VALVE HOLDER**

Fix this efficient component and get maximum results. Positively no leakage or capacity effects. Perfect contact. Can be mounted on front or back of panel.

Price 1/9 Postage 3d.

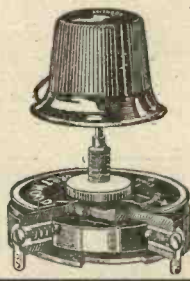

Barclays 895.

**BRETWOOD ANTI-CAPACITY SWITCH**

Bretwood Specialities are known throughout the wireless world to be the last word in scientific achievement, and constructors will welcome news of a further Bretwood Product, an Anti-Capacity Switch, the principal features of which include:—

Absolute freedom from capacity effects—Perfect Contact—Workmanlike finish and neatness of appearance—Simple single hole fixing and Easy to make wiring connections. Special spring loaded balls in the base make the Bretwood Switch wonderfully smooth in action and ensure clean and perfect electrical contact at all times. It is confidently offered to wireless constructors as the Anti-Capacity Switch par excellence, and of course it carries the famous Bretwood Guarantee.

PRICE 5/-

Postage 3d



Improve every circuit

No matter how simple or complex is the circuit in the receiver you make, there is a type of Bowyer-Lowe Square Law Condenser suitable in type and capacity, that will give a greater wavelength range and purity of reception than otherwise could be obtained.

These condensers are stocked by good dealers in Single, Double and

Triple Types, with or without Vernier, and in a range of capacities covering every requirement.

Only the Bowyer-Lowe Condenser gives the square law effect with increased capacity ratio and with losses reduced to a minimum. Insist on having Bowyer-Lowe Condensers in all your sets.

**Bowyer-Lowe Tested Radio Components**

BOWYER-LOWE Co., Ltd., LETCHWORTH.

another room. These sets have no physical connection with the aerial system, but so long as the aerial is tuned it will be found that reception will occur in each receiver, even when it is some distance from the tuned aerial or in another room. When two or more aerials of different types are in use the interaction is very strange. I have been able to reduce the wavelength of a receiver from 200 to 60 metres by making use of this interaction between various aerial systems. By this I mean enable a receiver which has a normal minimum wavelength range of 200 metres come down to 60 metres temporarily.

It is found also that if a valve receiver is in use in a house close to my own the variation of tuning in this receiver can affect the tuning of my own when I am tuned to a weak distant station. There is no other aerial really close to my own aerial.

While experimenting with transmission on very short waves, such as one and two metres, I have found interaction effects very marked. Another receiver left tuned by accident will have a great effect upon both the aerial current of the transmitter and the wavelength. I have found it necessary to totally enclose my transmitters in a shield and also work them in

another room before I could avoid this interaction.

But several interesting lines of thought spring from an experience such as this. There appears here to be a type of absorption of energy or signal strength which contradicts the idea that additional receivers in any one district have no effect upon the strength of the reception in those previously existing. It also gives point to a theory of my own that certain types of fading are due to absorption by an interfering station which is not sufficiently close to the received station to be actually audible in the receiver. Again, it leads to a line of work in the problem of the elimination of static, since I have found myself by using a receiver in a room where there are other receivers tuned to various wavelengths it is possible to eliminate static in the receiver in use by varying the tuning of the receivers not in use.

This may seem very involved, but it is the result of actual experience. The reason I am not able to give more definite data is purely owing to the amount of other work I have on hand having prevented me from following up the line of experiment.

—Yours faithfully,  
EDWARD C. DAVIES.  
Highgate, N.6.

TWO WIRING HINTS

SIR,—Please find enclosed two hints for set wiring, which may be of use to you. They have been employed in instrument works, and save a good deal of time.

To prevent mistakes when wiring a useful dodge is to draw a sketch of the panel with a piece of carbon paper, face upwards, underneath. The terminals and the over-all outline of the components are also drawn in position. If the wiring is now added it can be put in the actual positions that the connections will occupy.

Upon turning over these will be shown as viewed from the underside of the panel and so avoid the error of mistaking the ends of the panel.

A very convenient method of supporting a panel during wiring is to make four legs of brass rod. They can be made of screwed rod of a size that will slip through the fixing holes in the panel. A washer of about 1/2-in. diameter should be soldered about 2 inches from one end of each, then a cloth washer to go between this and the panel. A nut should be used to fasten the legs to the panel so that it can be moved without the legs falling out. The length of the legs will depend upon the height of the projections on the panel.—Yours faithfully,  
Charlton, S.E. F. C. BRYAN.

THE  
TANGENT RANGE  
OF  
LOUD SPEAKERS



Concert Model.



Tangent Tall Boy.

Every "Tangent" tells its story with the marvellous tone and tune with which it reproduces the speech and music your valve or crystal has culled from the ether.

It tells the story by its every perfection; of 30 years' experience; of care and consideration given to every part and proportion, all balanced in such happy combination as to produce perfect speech and accurate music.

Obtainable from all good dealers—any difficulty, write us.

- "Concert Model" (as illustrated) - - - - £5 0 0
- "Tangent Tall Boy" (as illustrated), 30 in. high - £5 0 0
- "Baby Tangent," 16 1/2 in. high - - - - £2 2 0

GENT & CO., LTD. Faraday Works, LEICESTER  
Est. 1872.

London:—25, Victoria Street, S.W.1.

Newcastle/Tyne:—Tangent House, Blakett Street.



**THE FOUR-VALVE FAMILY RECEIVER**

SIR,—Having constructed the "Four-Valve Family Set," from Radio Press Envelope No. 2, by Percy W. Harris, M.I.R.E., I thought you would be interested to see some photographs (page 832), including the home-made cabinet. The panel and loud-speaker, etc., are all enclosed. Also the accumulator and batteries are out of sight, and the whole presents a neat piece of furniture, and all is tidy.

The construction of the cabinet was my first experience at wood-work and I found it most interesting and not so difficult as I anticipated. The finishing was more trying, as I tried french polishing for the first time; this calls for patience, but one is well rewarded by the results.

I have arranged a fixed frame aerial in the top part of the cabinet, so in case of lightning I can disconnect the outdoor aerial and switch over to the frame. S.P.S.T. Battery switches are provided, so that anyone not used to "tuning-in" can switch on without interfering with the filament resistances or wander plugs. A D.P.D.T. switch is also added for either loud-speaker, one of which is permanently installed in the cabinet and the other used in various parts of the house.

I have fixed Oriental muslin in the top part of the cabinet, which hides the loud-speaker but allows the sound to pass through. Wishing you all success.—Yours faithfully,

F. W. WENHAM.

London, W.13.

**AN IMPROVED TWO-VALVE RECEIVER**

SIR,—I have recently completed the Improved Two-Valve Receiver by Stanley G. Rattee described in *Modern Wireless* of January last. I am getting excellent results, using constant aerial tuning, all B.B.C. stations, including Aberdeen and Birmingham, both of which are very difficult to tune in here. My place being subject to interference from local picture house, electric pumps, ice-cream mixers, dough mixers, etc., Bournemouth, notwithstanding, comes in at excellent strength on loud-speaker.—Yours faithfully,

Paignton. HAROLD SANDERS.

**THE TRANSATLANTIC V.**

SIR,—I am writing you concerning my excellent results which are obtained with Mr. Harris's "Transatlantic V," described in *Modern Wireless* of June, 1924.

The general appearance of my set is identical with the original, the

panel being 22 in. by 11 in., and all measurements being as given.

The radio-frequency circuit is exactly copied from the article, but on the audio-frequency side I have used transformer (2 Ferranti H.D.) coupling, which causes no trouble and gives very pure amplification. I have used two Utility lever switches, by which means I can use 3, 4 or 5 valves. The L.F. valves are two Marconi R type.

No fears need be entertained that this set is only good for distant stations, for Chelmsford is received on it most clearly and with a tremendous volume. All B.B.C. stations are received at excellent loud-speaker strength (Amplion Dragon standard), together with three relay stations (Leeds, Plymouth, Swansea), all of which can be received on the phones.

This set seems to have a special attraction for German stations—Cassel, Nuremberg, Hamburg, Munster, Breslau, Stuttgart, Koenigsberg, Frankfort, Leipzig, Munich and Berlin being all received well on the loud-speaker. Munster and Berlin often threaten to exceed Cardiff in volume!

Trusting that this will be of interest to you and to your readers.—Yours faithfully,

JOHN F. WEBBER.

Exeter.

**HAWK COILS**

**MAXIMUM**

Efficiency

Strength

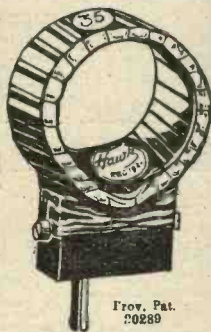

Prov. Pat. 20289

**MINIMUM**

Capacity  
Damping Effects  
Resistance

Prices below

WATERPROOF

Coil	Wave Length using .001 Variable Condenser in Parallel		PRICE.
	MAXIMUM	MINIMUM	
13	—	—	2/-
25	395	190	2/4
30	495	240	2/4
35	515	300	2/6
40	680	370	2/8
50	835	485	3/-
75	1250	600	3/4
100	1820	815	3/10
150	2300	960	4/8
200	3100	1870	5/4
250	3750	2200	5/8
300	4500	2300	6/-
400	4950	2500	6/8

Sold by all Wireless Dealers

Sole Manufacturers:

**The Hawk Coil Co., ST. MARY'S ROAD, SURBITON, SURREY.**

**Quality RADIO COIL HOLDERS AND COMPONENTS**

**PANEL COIL HOLDER**  
(Without Base).

All connections are made at the back, eliminating flexible wires with their untidy appearance, added capacity, and liability to breakage.

Best matt ebonite, anti-capacity handle with polished knob and polished and lacquered brass parts,

2-way, 3/-; 3-way, 5/-,

N.F. 1/- extra.

Drilling template supplied.

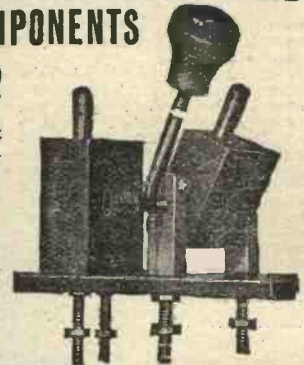

**Quality RADIO LEGLESS VALVE HOLDER. ANTI-CAPACITY.**

Acts as its own drilling jig.

1/6 each, postage 2d.



**Quality RADIO COIL PLUGS**

Type "H," flush fitting underpanel mounting. 1/- each, postage 2d. Template supplied,



If your dealer has not got them we send post free if you mention his name and address. LIST POST FREE.

**GOSWELL ENGINEERING CO., LTD.,**  
12a, PENTONVILLE ROAD, LONDON, N.1.

LIBERAL TRADE TERMS

Phone: North 3051.

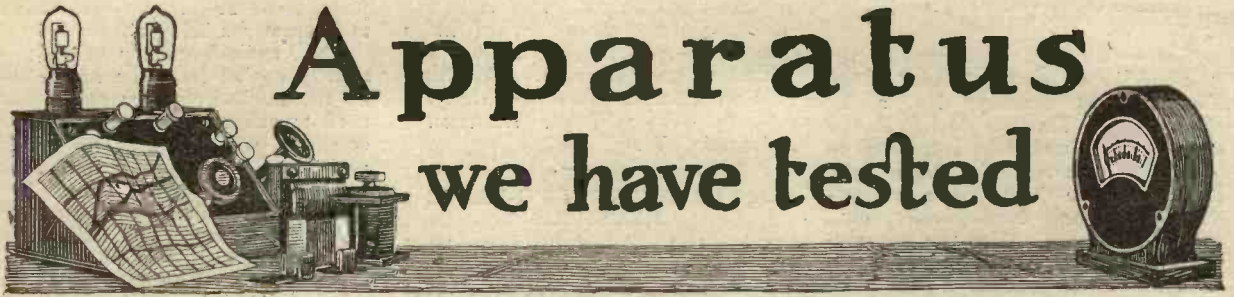

# Apparatus we have tested

Conducted by A. D. COWPER, M.Sc., Staff Editor.

## Lissen Radio Chokes

Messrs. Lissen, Ltd., have submitted for test a sample of their radio-choke, of high inductance and small effective distributed capacity, for use in Reinartz reaction circuits of the modern type, and for other purposes for which such a choke is indicated. This is uniform in appearance with their low-frequency or audio-choke, being mounted in a moulded case  $1\frac{1}{4}$  in. diameter by  $3\frac{1}{4}$  in. high, on a flanged base drilled for fixing behind the panel or on a baseboard by two small screws. Small terminals on the upper surface of the same flange provide for electrical connections. The whole would occupy a space of about 3 in. by  $1\frac{1}{2}$  in. on the panel, of lozenge shape. We gather that this choke has a very large number of turns

of fine wire, pile-wound, on an ironless core, giving small effective capacity but the necessary very large inductance; on practical trial, it was found to be adequate up to and beyond the wavelength of Eiffel, when used in a Reinartz type of receiver with only the 'phones as effective impedance in the plate circuit, with a hard R valve and limited H.T., giving smooth reaction and good oscillation control when using a fixed Reinartz reaction-coil of moderate size.

An earlier pattern of Lissen radio-choke of narrow disc type for direct mounting on the terminal of a reaction condenser has also been tested, and showed the same useful range as this later pattern; the earlier type has been referred to

elsewhere. Either pattern is eminently suitable for use in a Reinartz receiver with fixed plug-in coils, to cover the whole available telephony range.

The finish and workmanship of these chokes was up to the usual good standard set by Messrs. Lissen, Ltd.

## A Large-Range Filament Resistance

From Messrs. Gerrard Radio Stores come samples of their new pattern of micrometer-adjustment filament resistance, giving an unusually large range. An earlier pattern of this instrument was reviewed in these columns some time ago. The customary one-hole fixing is provided, with a range from  $\frac{1}{8}$  inch to about 5-16 inch for panels of varying thickness. Connections

## The COLVERN Neutrodyne Condenser

Extract from a Test Report by A. D. Cowper, M.Sc., in "Wireless Weekly," December 17th, 1924.

"On practical trial was found to be admirably adapted for its purpose; the 'zero' capacity was minimal, and the effective range ample for its purpose. Both with the type of neutrodyne tuned-anode H.F. coupling with plug-in coils, and with the convenient modification introduced lately by Mr. F. W. Harris, using a mushroom H.F. plug-in transformer for anode and neutrodyne coil together, satisfactory neutralisation of valve capacities resulted, and complete stability with light aerial-coupling and sharp, selective critical tuning."

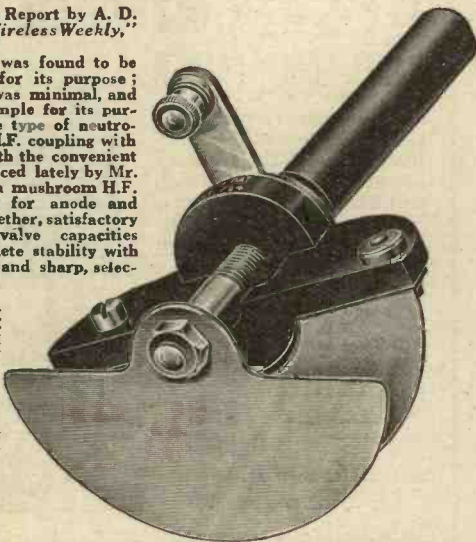

PRICE

**3/6**

Overall size under panel  $2\frac{1}{2}$  in. diameter.

One-hole fixing and supplied with an anti-capacity extension handle.

THE COLVERN General Purpose Vernier provides a means of obtaining perfect balance of all tuned circuits. Fit one to the secondary or reaction circuits, and you will appreciate what accurately tuned circuits can do for your reception. An enthusiast writes:—"H.F. Tuning is now a pleasure of greatest ease." Another says:—"My set was constantly howling and I could not get clear signals. With the COLVERN fitted I can quickly get splendid clear reception."

Descriptive Folder on "Fine Tuning" upon application.

Price **2/6.**

If your local dealer cannot supply, kindly send his name and address when ordering.

**COLLINSON'S PRECISION SCREW Co. Ltd.,**  
Macdonald Road, Walthamstow, London, E.17.  
Telephone—WALTHAMSTOW 532.

Barclays 913.

## "CLARKE'S ATLAS" FILAMENT CONTROL

Works on an entirely new principle. No wires to scrape and scratch. No powder to cause troublesome "Packing."

Gives astoundingly easy control of bright or dull emitters—a marvel of noiseless efficiency.

Economises current; lengthens the life of your valves, and is a deciding factor in bringing in those illusive stations. 30 ohms resistance... One hole fixing.

Sole Manufacturers:—



Price **6/6** each

From all good dealers

**H. CLARKE & Co., (Mcr.), Ltd.**

Atlas Works, Old Trafford, Manchester.

\*Phones: 683 & 793 Trafford Park.

\*Grams: "Pitroad, Manchester."

are made to small soldering tags; a comfortable, large controlling knob is provided on the spindle, secured by a substantial grub-screw. The available range, on trial, was from about 1 to 150 or 200 ohms, with several turns of the knob. In the early samples submitted, the action was somewhat irregular for purely mechanical reasons; this will doubtless be remedied by the makers in later patterns when production is fully organised. The range of possible fine adjustment is very great in this device; the common difficulty of "packing" inherent in carbon-compression rheostats appears to have been largely overcome here. We shall be interested in any future development of this type of mechanism for overcoming the packing difficulty, as there are many possible applications of a large-range carbon variable resistance in experimental work, apart from the need for such an instrument in valve receivers when D.E. valves are adopted.

**Cartridge Filament Resistance**

We have received from Messrs. Enterprise Manufacturing Co., Ltd., several samples of their "Micro-meter Filament Dimmer," in which the resistance element takes the

form of a small cartridge, introduced into a cylindrical fitting of the usual one-hole-fixing type. The casing is about 2 inches long by a little under  $\frac{1}{2}$ -inch diameter, and is similar to that of a variable grid-leak with cartridge inset, already reviewed in these columns. The cartridge is also in the form of a rubber tube,  $\frac{3}{4}$  inch long by  $\frac{1}{16}$  inch diameter, with brass end-plugs, and contains the carbonaceous resistance powder. Four different ranges are provided by the makers, nominally from 0 to 5, 10, 20 and 30 ohms respectively. Those tested were marked 0-5 ohms.

On practical trial the resistance-range was from about 0.4 to 100 ohms in each sample, but the adjustment was jerky above about 30 ohms. The range from .4 to about 30 ohms was covered swiftly, in one-half turn of the controlling knob. For turning on and off a bright-emitter type of valve, requiring an adjustable filament-resistance of only a few ohms for adequate control of not too critical nature, these cartridge resistances will evidently suffice for the range indicated by the makers. It is an obvious advantage to be able to replace the low-range cartridge by one of higher rating when changing over to D.E. valves from bright-emitters.

**"L.E.S." Micro Filament Control**

Samples of the latest pattern of their fine-adjustment filament-controlling resistance have been submitted by Messrs. London Electric Stores, Ltd. This is of the familiar cylindrical, one-hole fixing type, measuring  $1\frac{1}{8}$  inch long below the panel, by  $\frac{1}{2}$ -inch diameter. The fixing device (the usual screwed collar and bush) will accommodate itself to panels ranging from  $\frac{1}{8}$  inch to  $\frac{3}{8}$  inch thickness—a commendable feature. A substantial knurled insulated knob is provided on the controlling spindle; connections are to be made to soldering tags on small terminal screws on the side of the barrel.

On test the different samples showed a steady adjustment from about 0.3 to some 200 or 300 ohms maximum, with smooth, silent variation, easily controlled, between these points. In actual reception, smooth control of a detector valve and of self-oscillation became possible; and D.E. types of valves could be operated safely from a large accumulator battery.

The various samples showed a uniformity of behaviour, and appeared to be soundly constructed and well finished. We can recommend this type of filament resistance, particularly for use in critical circuits requiring fine control.

**C.A.V. WIRELESS PRODUCTIONS**

**IMMEDIATE DELIVERY**  
from all good Wireless Dealers.

**LOUD SPEAKERS**  
**STANDARD**  
2000 ohms £5 0 0  
4000 ohms £5 10 0  
120 ohms £4 15 0  
**JUNIOR**  
2000 ohms £2 15 0  
Black Crystalline or Black Satin Enamel.  
**TOM-TIT 30/-**  
2000 ohms  
Black Crystalline or Bright Stone Enamel.  
**TRANSFORMER, L.F.**  
For the first and second stages of 27/6 amplification  
**C.A.V. ACCUMULATORS**  
for wireless are the result of 32 years' manufacturing experience.

**C.A.V. ACCUMULATOR**  
60 v. H.T. £3

Write for Loud Speaker and Accumulator folders.

**C.A. Vandervell & Co., Ltd.**  
ACTON VALE, LONDON, W. 3

**Lissen Neutrodyne Condenser**

A very neat type of "neutrodyne" condenser for use in various types of H.F. amplifying circuits in which the valve-capacities have been partly or wholly neutralised by some feed-back device involving a very small, adjustable condenser (in order to achieve stability when a lightly-damped first grid circuit, or where many stages of H.F. amplification are involved) has been submitted by Messrs. Lissen, Ltd. This small instrument is of the usual one-hole-fixing type, and, in fact, recalls a carbon-compression type of filament control, being contained in a small cylindrical case only 1½ inches long by 1-inch diameter. It is actuated by a long, knurled-top ebonite knob; the usual small soldering-tags on small screws in the side are provided for connections. The instrument is of the two-plate variety, having one fixed circular plate at the end of the container and a moving plate advanced towards the former by a micrometer-action controlled by the external knob. On measurement, the minimum capacity, eliminating the capacity of the leads, was about 0.9 μF with the plate screwed out to the full distance of some ⅝ inch; the maximum available, just before the plates touched, was around 7.7 μF, giving a suitable range of adjustment and

the necessary very low minimum for an effective neutrodyne condenser. Tried in the tuned-anode modification of the Hazeltine neutrodyne circuit advocated by the writer, it proved to give excellent control, and effective neutralisation of plate-grid capacities with a very lightly-loaded grid circuit and full negative grid-bias, using a neutralising coil in a two-coil holder of about the same size as the tuned anode coil itself, and fairly closely coupled to the latter.

The instrument is well finished, and operated extremely smoothly; we can, accordingly, recommend it for the purpose indicated, as well as for final fine-tuning in critical circuits, for which purpose the compactness of the instrument will give it a special appeal.

**Micrometer Crystal Detector**

We have received from Messrs. The General Electric Company a sample of their "Micrometer" crystal detector, fitted with a "Gecosite" crystal. This detector is of the horizontal glass enclosed type, fitting between spring supports on an ebonite base 2½ in. by 1½ in. The latter has screw-holes for fixing on the panel, etc. Substantial plated terminals on the base provide for connections. The instrument was dismantled with much greater ease than usual, and was

firm and secure when reassembled. The crystal is secured by a flanged knurled ring screwing on a cup base fixed to one end of the case, and is immediately accessible for replacement or re-adjustment in its holder. A special point is the micrometer adjustment of the whisker, which was found, on trial, to work with the most delightful delicacy and certainty, and to give a light contact with the excellent springy whisker provided. The adjustment was not easily disturbed by vibration. The whisker-holder is mounted in the ordinary type of ball universal joint, but rotation of an insulating knob at the end of the adjusting rod advances or withdraws the former by a fine micrometer screw action, a spiral spring taking up all back-lash.

This detector has evidently been the subject of very careful design. The workmanship and finish are excellent, and the insulation resistance of the base passed severe test. We might suggest that the area of crystal surface exposed by the holder is rather unduly limited, so that the sensitive spots would be rapidly exhausted in daily use for broadcast reception, and that the holder might, with advantage, be made to take a rather larger fragment of crystal. The "Gecosite" crystal supplied with the instrument proved excellently sensitive on trial.

**DIALS FOR ALL REQUIREMENTS**

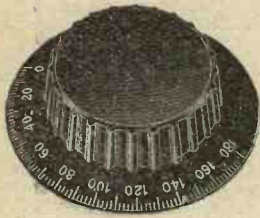

Splendid range of superior, highly polished dials with scale 0-180 clearly engraved. These combined knobs and dials are held securely by means of a small grub screw; they fit flush to panel and the deeply fluted grip gives splendid control when making tuning adjustments.

SIZES:—

DIAL (dia.)	KNOB (dia.)	PRICE (each)
2½ ins.	1½ ins. (as illustrated)	1/3
2½ ins.	1½ ins.	1/2
2½ ins.	1½ in.	1/-
1½ ins.	1½ in.	8d.



**About Crystals**

Wireless crystals are made in both Chemical Laboratories and Nature's Own Laboratories; diamonds and pearls are also produced by both these methods.

**WOULD YOU BUY A MANUFACTURED DIAMOND?**

**G.R.S. Crystal**

is a natural Galena, each piece of which is selected, tested and guaranteed by us. It is advisable to occasionally change and rest your crystals, and for that reason we offer:— Three small or 1 large piece in sealed boxes at 1/- each, or post free 1½.

**GERRARD RADIO STORES,**  
15, LITTLE NEWPORT STREET, LONDON, W.C.2.

Trade Enquiries Invited.

Barclays 911

**G.R.S. Micro-Rheo**

(Illustration is half actual size). Suitable for all types of dull and bright emitter valves. It is of the single-hole fixing type, and may be secured to the panel by drilling a ½-in. hole. The knob is held by means of a small grub screw and can be easily removed. Unlike some types of rheostats, the special carbon used will not pack and consequently the variation of resistance is uniform and consistent.

A filament control of infinite precision, continuously variable from 0-200 ohms., price 3/6. Post free 3/9

If you cannot obtain from your dealer, write to—



**Purity of Tone**

and volume can only be secured by using L.F. Transformers which give high amplification without distortion. THE HERALD is built and designed to give these results.

Sold by all Dealers under our 10 days' test guarantee. Money refunded if our claims are not substantiated. Send 3d. for Complete Components Catalogue. Trade should write for full range of Radiax Sets and Components.



**RADIAX Ltd.**

60, RADIO HOUSE, PERCY ST., TOTTENHAM CBT. RD., LONDON, W.1.  
3 mins. from Tottenham Court Rd. and Goodge St. Tube Stations. Phone: Museum 490

PRICE 12/6.

Barclays 901.

**The Improved and Cheaper Coil Plug**

**SAVE 25%**

Get REAL EBONITE Coil Plugs for 5/- per doz. (4/9 gross lots). Made of best tested materials throughout, these Plugs offer the advantages of nickel-plated side plate contacts, having patent lip.

**CECIL RIDLEY**  
35 & 37 DUNDAS MEWS  
MIDDLESBROUGH

TELEPHONE 1366.

# Information Department



SUPPLIED BY RADIO PRESS SERVICE DEPT., LTD.

**R. J. (BERKHAMSTED)** writes that he wishes to attach some ivorine scales to his panel without drilling, and asks for suggestions.

The most convenient adhesive for this purpose is celluloid cement such as is used for repairing accumulators, and it will be found to be quite satisfactory so long as the ebonite panel has not been treated with vaseline or oil after rubbing down. If this latter is the case, it may be necessary to mark the outline of the scale on the panel, and then carefully rub over this surface with emery to remove any traces of grease. This being done, the under surface of the ivorine scale should be rubbed over with emery paper and liberally smeared with celluloid varnish. Leave it exposed to the air for a few minutes until it

becomes sticky, and then press the scale firmly upon the panel, and place a weight upon it until dry.

**A. S. O. (TONBRIDGE)** is having considerable difficulty as the result of the stretching of his aerial hal-yards, and asks for any suggestions. He uses manila rope for the purpose, and he finds that the aerial requires constant attention according to atmospheric conditions, and he has been advised to use finely stranded steel cable in preference, but has considerable doubts as the efficiency of this material from the electrical point of view.

Ordinary untreated rope is certainly most unsuitable for the purpose, and if rope is used at all it should be of the tarred variety. Good tarred hemp is fairly suitable,

since after the initial stretching it becomes fairly constant, and is not much affected by weather conditions. It will only require tightening at quite long intervals.

With regard to the galvanised steel rope recommended, evidence is lacking as to any possible loss of efficiency, and we are inclined to doubt whether such loss is worth taking into account under ordinary receiving conditions. Experiments have certainly been carried out with a view to deciding this point, but the effect was so small that it could not be observed under ordinary receiving conditions. If it is decided to use the galvanised steel wire care should be taken to obtain a really good sample, since on some varieties we have seen, the galvanising was extremely thin and the wire would be likely to have only a short life when exposed to atmospheric

Prov. Pat.

## "CHASEWAY" .001 to 20 megs. sets the new standard for VARIABLE GRIDLEAKS

From letters received by us from all parts of the country, it is obvious that until the new "CHASEWAY" was evolved, a really reliable gridleak was badly needed. "CHASEWAY" VARIABLE GRIDLEAK has set the new and much higher standard, not only in the manufacture, but in the expectations of gridleak users. Those who have previously found it necessary to constantly renew the gridleak are happy to find that in installing the "CHASEWAY" they have a gridleak RELIABLE FOR ALL TIME, and of remarkable sensitivity, bringing in remote stations and literally constituting the "nerves" of the set. No pellets, no liquids, and no cardboard, the "CHASEWAY" IS A SCIENTIFIC INSTRUMENT.

GRIDLEAK .001 to 20 megs. 4/- ASK YOUR DEALER  
Anode resistance 10,000 to 500,000 ohms, 4/-

It is possible he has none owing to the fact that he has large stocks of the old fashioned makes, which he naturally cannot afford to scrap—but this need not stand between you and the finest gridleak made, so remit direct and give his name if difficult. Illustrated catalogue of the famous CHASEWAY HOME BATTERY CHARGERS and other novel necessities on receipt of stamp. Phone Central 1539. The Chase Electrical Mfg. Co., Ltd., 184w, Fleet Street, London, E.C.4

V. Pethick—Advertising—London.



4/-

SEND

# £1 Only

Send 20/- to day, together with your order for the "Tonyphone," and this wonderful set, which receives all B.B.C. stations, will be delivered complete, including all accessories. You pay a further £1 each month afterwards. The total cost is only £15 9s., or if you prefer, £14 5s. cash.

### "TONYPHONE" SUPER TWO-VALVES

Complete with Accumulator, R.T. Battery, Aerial 1 pair 4,000 ohms Head-phones, and two Valves—one High Frequency and one Detector. All Royalties paid.



Send to-day and enjoy broadcasting NOW.

**BRITISH ENGINEERING PRODUCTS CO.**  
(Wireless Dept.), Windsor House, Victoria Street, London, S. W.1.  
S.S.A.

Don't fiddle the Crystal—use

## Harlie FOOL-PROOF DETECTOR

Provisional Patent 26791/24.

Continuous reception in any position at all times, owing to the special design of both crystal and catwhisker, always in contact.

**GUARANTEED TONE—VOLUME—PURITY**  
**SOME NOVEL FEATURES:—**

1. Nickel plated detachable dust proof cover.
2. Special "Harlie" super sensitive crystal.
3. Ebonite wheel for rotating crystal. No fumbling about adjusting, just turn the wheel—simply itself.
4. Catwhisker on slider for covering whole surface of crystal. Shock-proof.
5. Nickel plated sockets for panel mounting.

Obtainable from all dealers or direct from patentees and manufacturers. **PRICE COMPLETE 5/6**  
Generous Trade Terms. Telephone: Cllasold 293.  
**HARLIE BROS., 183 DALSTON LANE HACKNEY, LONDON, E.8.**

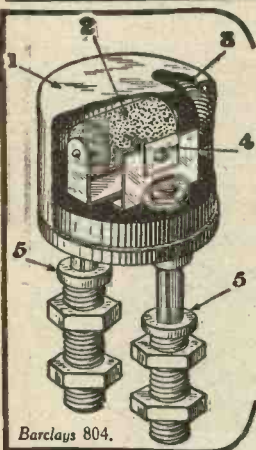

Barclays 804.

## "BELLING-LEE"

INDICATING TERMINALS.  
Patent No 680724

MULTY-KONTACT PLUGS & SOCKETS  
Patent Nos. 205010 & 267437/24

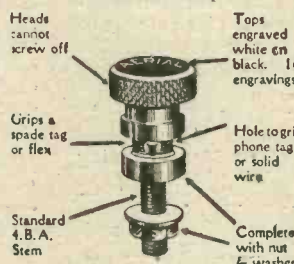

PRICE 3½<sup>d</sup> EACH BRASS  
4½<sup>d</sup> EACH NICKEL

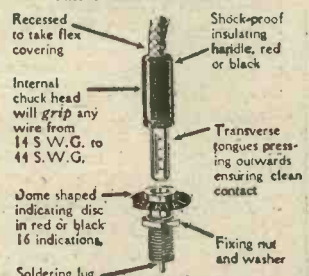

PRICE 7<sup>d</sup> per set  
NICKEL PLATED

Your dealer can supply you. In case of difficulty, write direct to—**BELLING & LEE, LTD., QUEENSWAY WORKS, PONDERS END.**

conditions. On the other hand, a good specimen will last an extremely long time, and we know of one set of halyards which were erected in 1919 and are still in perfectly sound condition.

C. F. A. (CAMBRIDGE) is constructing a super-heterodyne receiver from an American design and asks for details for the home construction of intermediate frequency semi-aperiodic transformers.

It is a somewhat difficult piece of work to turn out a good transformer of this type, much tedious winding of fine wire being involved, but the following data should provide a transformer of fair efficiency. Use one of the standard barrel type ebonite formers employed for long-wave transformers of the semi-aperiodic type, suitable dimensions being—length 3 inches, diameter 2 inches. Eight grooves should be cut in this former, an eighth of an inch wide, and half an inch deep, four grooves serving for the primary and four for the secondary, the windings, of course, being put on in alternate slots. In each groove wind 500 turns of No. 42 single silk-covered resistance wire, connecting the alternate slots in series in the usual manner. The trans-

formers for successive stages should be roughly matched, and a certain amount of care should be taken in counting the turns. Three of these transformers can be used together with very little difficulty from instability, provided they are spaced somewhat apart, say, 6 inches, and a potentiometer should be provided for the control of the natural tendency to self-oscillation.

M.I.R. (BEDFORD) states that he is very much troubled at frequent intervals by what he believes to be showers of electrically charged rain. During these showers he hears a continuous pattering noise which gives rise to a continuous roar, which completely prevents reception, and occurs so frequently that it is becoming a serious problem to him.

The symptoms certainly agree with frequent showers of charged rain, but the fact that they occur so frequently that they average one per week strikes us as extremely unusual. We infer from our correspondent's letter that this has been going on for some months; we are, therefore, a little doubtful whether the cause should not be sought in some artificial source, such as some kind of electrical machinery in his neighbourhood, a defective switch in the house-lighting installation, or

some other cause of this nature. To settle the point we suggest that our correspondent should try the effect of an indoor aerial of good size, noting whether the noise is very much reduced, or whether it is merely reduced in the same ratio as the signals from the station with whose strength he is familiar. Should they be almost completely eliminated, charged rain is, no doubt, the cause, but if they are only reduced in the same ratio as the signals, it is more likely that the alternative explanation is the correct one.

H.F. Transformer for Single Stages

(Concluded from page 820.)

nected through the winding to the IS pin, and assuming that a satisfactory click is obtained it is then screwed down under the OS pin.

It will probably be found when using one of these transformers, that the set oscillates much more easily than before, and it may be necessary to use either a potentiometer or reversed reaction to stop it from doing so.

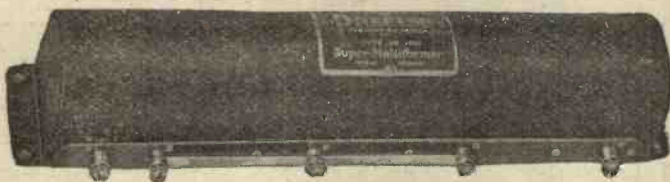

**The PRECISE SUPER MULTI FORMER**  
*One Instrument Which Does the Work of Four.*

Replaces all long wave transformers in any type or modification of the Superheterodyne circuit. This instrument has met with the unanimous approval of noted radio experts and is already demanded by the public which is rapidly learning of its superiority over the conventional type of Super heterodyne transformer. It cuts in half the time and eliminates all trouble in building a Superheterodyne and insures the builder of successful results due to the short connections that are required from the instrument to the respective valve sockets thus preventing the experimenter from unconsciously causing undesirable coupling between circuits.

**Price £4 17 6.**

Fully illustrated constructional booklet including full size drawing on building the McLaughlin Super Heterodyne ... 5/-

N.B. All our products are fully tested and guaranteed by our Principal, C. G. Vokes, A.M.I.Mech.E., etc.

**C. G. VOKES & COMPANY, 38, Conduit St., Regent St., W.1.**  
Telephone: Gerrard 4693.

Wireless Gramophone Loud Speaker.

**The Dulce-Tone**

*is a Link between Your Wireless Set and the Gramophone.*

The Dulce Tone is NOT AN ATTACHMENT. It is used simply by placing the needle of the gramophone on the vibrating reed of the Dulce Tone. It does not require the removal or change of any part of the machine. Dulce Tone can be used and then laid aside as easily as a record—in fact, the operation is virtually the same. Hence, it does not reduce the use or availability of the gramophone for the playing of records.

**Price £2 10 0.**

**FREE GIFT**

To all purchasers of either of the components advertised, sending the name and address of their local dealer, we will forward post free a dainty nickel-plated match box holder and ash receiver for car or home use, sold in the Motor Trade at 7/6 each.





## “To Switch or not to switch!”

The complex problem of deciding whether or no a certain circuit or component should be switched, and the best method to adopt when the answer affirms the question, is the subject of an attractive book by Oswald J. Rankin entitled “Switches in Wireless Circuits.”

This is one of the latest additions to the series of authoritative books on wireless, published by Radio Press, Ltd., and like its predecessors is written in an accurate, yet perfectly readable manner. Profusely illustrated with diagrams, shown both theoretically and pictorially, the contents give over 50 different switching arrangements covering practically every requirement.

All difficulties heretofore associated with the trouble of switching will vanish with the purchase of this book and the danger of valves burning out or possible battery damage will be completely eliminated.

*Ask for the book with the distinctive yellow cover, the Radio Press Series No. S22, Price 1/6. Obtainable from all Newsagents, Booksellers, your local Wireless Dealer, or direct from the Publishers Post free 1/8.*

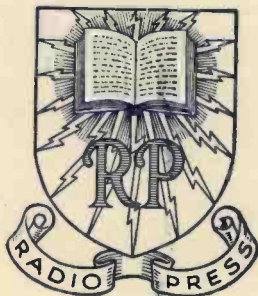

**Radio Press, Ltd.**  
BUSH HOUSE, STRAND, LONDON, W.C.2.

# For 22'6 now!



The increased demand for these famous headphones following the recent announcement of price reduction is ample evidence of the keen sense of value possessed by the public.

Sterling Lightweight Headphones at the old price were universally acknowledged as the best value procurable—at the reduced price the value offered remains incomparable.

Comparison with headphones at any price has shown the superiority of Sterling Headphones in efficiency, design, finish and value. In the words of the radio slogan: "Those who buy Sterling buy best!"

## STERLING LIGHTWEIGHT HEADPHONES

*At all Radio Dealers*

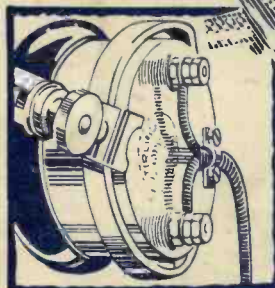

**I** The swivel and trunion movement which provides easy adjustment.

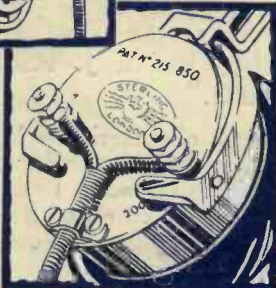

**II** The back view of one ear-piece—note the difference in construction.



**III** The highly efficient electromagnetic system.

Advt. of **STERLING TELEPHONE & ELECTRIC CO., LTD.**, Manufacturers of Telephones and Radio Apparatus, etc  
 Telephone House, 210-212, Tottenham Court Road, London, W.1 Works: DAGENHAM, ESSEX.

Printed for the Proprietors, RADIO PRESS, LTD., Bush House, Aldwych, W.C.2., by THE AVENUE PRESS (L. Upcott Gill & Son, Ltd.), 55-57, Drury Lane, London W.C.2. Published on Wednesday of each week at 3, Bolt Court, Fleet Street, London, E.C.4 Address for Subscriptions and Editorial Communications:—Bush House, Strand, London, W.C. Advertisement Managers:—BARCLAYS ADVERTISING LTD., Bush House, Strand, London, W.C.2 Registered as a newspaper and for transmission by Canadian Magazine Post. Subscription rates:—32/6 per annum, 16/3 for six months post free. Sole Agents for Australasia:—GORDON & GOTCH (Australasia), Ltd. For Canada:—IMPERIAL NEWS LTD For South Africa:—CENTRAL NEWS AGENCY, LTD. For Japan:—SALE & FRAZER, LTD.